



# CUTR

CENTER for URBAN  
TRANSPORTATION  
RESEARCH

## **Coordinated Pre-Preemption of Traffic Signals to Enhance Railroad Grade Crossing Safety in Urban Areas and Estimation of Train Impacts to Arterial Travel Time Delay**

**Final Report (Revised)**

**January 2014**

**PROJECT NO.**  
BDK85 977-44

**PREPARED FOR**  
Florida Department of Transportation

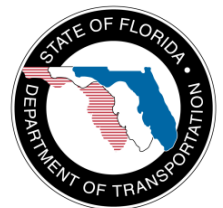

Center for Urban Transportation Research  
University of South Florida  
4202 E. Fowler Ave., CUT100, Tampa, FL 33620-5375

---

# Coordinated Pre-Preemption of Traffic Signals to Enhance Railroad Grade Crossing Safety in Urban Areas and Estimation of Train Impacts to Arterial Travel Time Delay

BDK85 977-44

## Final Report (Revised)

Prepared for:

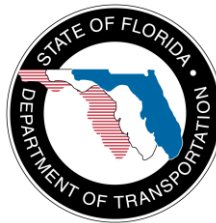

### Florida Department of Transportation

Melissa Ackert, P.E., Project Manager

Prepared by:



### USF Center for Urban Transportation Research

Pei-Sung Lin, Ph.D., P.E., PTOE, FITE, Program Director

Zhenyu Wang, Ph.D., Research Associate

Rui Guo, Graduate Research Assistant

Qing Wang, Graduate Research Assistant

### Texas A&M Transportation Institute

Srinivasa Sunkari, P.E. Research Engineer

Praprut Songchitruksa, Ph.D., P.E., Associate Research Engineer

### FIU Lehman Center for Transportation Research

Xunawu Chen, Graduate Assistant

Yan Xiao, Ph.D., P.E., Research Associate

Mohammed Hadi, Ph.D., P.E., Associate Professor

January 2014

---

---

## **DISCLAIMER**

The contents of this report reflect the views of the authors, who are responsible for the facts and the accuracy of the information presented herein. This document is disseminated under the sponsorship of the Department of Transportation University Transportation Centers Program and the Florida Department of Transportation, in the interest of information exchange. The U.S. Government and the Florida Department of Transportation assume no liability for the contents or use thereof.

The opinions, findings, and conclusions expressed in this publication are those of the authors and not necessarily those of the State of Florida Department of Transportation.

# METRIC CONVERSION

SYMBOL	WHEN YOU KNOW	MULTIPLY BY	TO FIND	SYMBOL
<b>LENGTH</b>				
<b>in</b>	inches	25.4	millimeters	mm
<b>ft</b>	feet	0.305	meters	m
<b>yd</b>	yards	0.914	meters	m
<b>mi</b>	miles	1.61	kilometers	km
<b>VOLUME</b>				
<b>fl oz</b>	fluid ounces	29.57	milliliters	mL
<b>gal</b>	gallons	3.785	liters	L
<b>ft<sup>3</sup></b>	cubic feet	0.028	cubic meters	m <sup>3</sup>
<b>yd<sup>3</sup></b>	cubic yards	0.765	cubic meters	m <sup>3</sup>
NOTE: volumes greater than 1000 L shall be shown in m <sup>3</sup>				
<b>MASS</b>				
<b>oz</b>	ounces	28.35	grams	g
<b>lb</b>	pounds	0.454	kilograms	kg
<b>T</b>	short tons (2000 lb)	0.907	megagrams (or "metric ton")	Mg (or "t")
<b>TEMPERATURE (exact degrees)</b>				
<b>°F</b>	Fahrenheit	5 (F-32)/9 or (F-32)/1.8	Celsius	°C

# TECHNICAL REPORT DOCUMENTATION

1. Report No.		2. Government Accession No.		3. Recipient's Catalog No.	
4. Title and Subtitle <i>Coordinated Pre-Preemption of Traffic Signals to Enhance Railroad Grade Crossing Safety in Urban Areas and Estimation of Train Impacts to Arterial Travel Time Delay</i>			5. Report Date <i>January 2014</i>		
6. Performing Organization Code					
7. Author(s) Pei-Sung Lin, Zhenyu Wang, Rui Guo, Qing Wang (CUTR) Srinivasa Sunkari, Praprut Songchitruksa (TTI) Xuanwu Chen, Yan Xiao, Mohammed Hadi (LCTR)			8. Performing Organization Report No.		
9. Performing Organization Name and Address <i>Center for Urban Transportation Research University of South Florida 4202 East Fowler Avenue, CUT100 Tampa, FL 33620-5375</i>			10. Work Unit No. (TRAIS)		
11. Contract or Grant No. <i>FDOT BDK85 977-44</i>					
12. Sponsoring Agency Name and Address <i>Florida Department of Transportation 605 Suwannee Street, MS 30 Tallahassee, FL 32399-0450</i>			13. Type of Report and Period Covered <i>Final Report (Revised) June 2012 – November 2013</i>		
14. Sponsoring Agency Code					
15. Supplementary Notes					
16. Abstract <i>This research project investigated the potential for using advanced features of traffic signal system software platforms (ATMS.now), prevalent in Florida, to alleviate safety and mobility problems at highway-railroad at-grade crossings and adjacent arterials. Pre-preemption phasing was developed in this study to provide "extra" green time to the movements blocked by a train before the train's arrival at the crossing in order to (1) mitigate congestion on the arterials near railways and (2) reduce the conflicts of train-vehicle and/or vehicle-vehicle adjacent to at-grade crossings. This study explored the technologies for implementing key functions of a pre-preemption system, including train detection, train arrival prediction, and pre-preemption control algorithms, and the capabilities of ATMS.now system. VISSIM-based simulation models were developed in this study based on three control sections along two railway corridors (FEC and CSX) in Broward County, Florida, to test the proposed pre-preemption strategies. A series of comparisons before-after implementing pre-preemption strategies was conducted to validate the effectiveness of pre-preemption strategies. The major findings and recommendations for implementation from this study are provided below.</i>					
<ul style="list-style-type: none"> <li>• <i>Upstream preemption signals (activation or release) are suggested for triggering pre-preemptions at downstream intersections along the railroad corridor. The Estimated Time of Arrival (ETA) is predicted based on the logs of two or more preemptions at upstream crossings with ideal space less than 0.5 miles.</i></li> <li>• <i>The coordinated pre-preemption strategy developed in this study aims to clear the through traffic at several intersections along an arterial as much as possible before train's arrival. All pre-preemption phases are pre-timed; coordinated pre-preemption is easy to be implemented on existing traffic controllers.</i></li> <li>• <i>Based on the simulation results, the coordinated pre-preemption strategy can effectively reduce average delay, average stops, and average queue length of the arterials near a railroad crossing. The performance pattern is sensitive to site features and strategy configurations. Considering its applicability and corridor-level effectiveness, coordinated pre-preemption is suggested when through traffic volume is higher than 500 vehicles per hour per lane (vphpl) and train block duration is longer than 100 seconds.</i></li> <li>• <i>A generic pre-preemption plan was developed in this study to provide guidance on implementation of the pre-preemption strategy using the ATMS.now system in Florida.</i></li> </ul>					
17. Key Words <i>Pre-preemption, preemption, traffic signal, highway-railroad at-grade crossing, traffic simulation, VISSIM</i>			18. Distribution Statement		
19. Security Classification (of this report) <i>Unclassified</i>		20. Security Classification (of this page) <i>Unclassified</i>		21. No. of Pages <i>157</i>	22. Price

---

## **GLOSSARY OF TERMS AND ACRONYMS**

### **Advance Preemption**

Traffic signal controllers receive notification of an approaching train earlier than railroad active warning devices.

### **At-grade Railroad Crossing**

An intersection where a roadway crosses railroad tracks at the same level or grade.

### **ATMS.now**

A central management system that brings traffic network data into a single repository for a real-time, integrated view of traffic operations.

### **AWT**

Advance Warning Time.

### **Congestion Clearance Phase**

The “extra” green-time is assigned one or more vehicle movement(s) along a roadway corridor before train’s arrival. The purpose of congestion clearance phase is to clear congested vehicle traffic in advance. It may be followed by a Track Clearance Phase.

### **Coordinated Congestion Clearance Phase**

This congestion clearance phase operates coordinately in the intersections near an at-grade crossing along a roadway corridor. Usually, the coordinated congestion clearance phases are assigned to through movement(s) on major approaches at the direction of commuter.

### **Coordinated Pre-preemption**

This strategy assigns “extra” green time to movements at several intersections along a roadway corridor at a coordinated manner before train’s arrival.

### **Coordinated Pre-preemption Phase**

See “Coordinated Congestion Clearance Phase.”

### **Control Section**

A railroad corridor and its adjacent urban arterials containing signalized intersections in which the coordinated pre-preemption strategy is implemented.

---

**CWT**

Constant Warning Time, usually 20-25 sec.

**DMS**

Dynamic Message Sign.

**Dwell Phase**

A preemption hold interval that permits vehicle movements that do not cross the tracks; occurs after track clearance interval until train has left detection zone.

**ETA**

Estimated Time of Arrival of a train.

**ETD**

Estimated Time of Departure of a train.

**EWS**

Early Warning System, a pre-timed early-preemption system.

**Exit Phase**

Once the train vacates the crossing, the traffic signal must transition back to its normal mode of operation. The first phase implemented is based on the minimum delay.

**FDOT**

Florida Department of Transportation

**FRA**

Federal Railroad Administration.

**Full Pre-preemption Phases**

A pre-preemption phase sequence containing congestion clearance phases (coordinated and/or non-coordinated), track clearance phases, dwell phases, and exit phases. Usually, the full pre-preemption phases are implemented in the intersections next to an at-grade railroad crossing.

**ITPS**

Improved Transitional Preemption Strategy, a dynamic traffic signal model prior to preemption.

---

**LOS**

Level of Service.

**Modified ITPS**

A modification of the ITPS algorithm to provide extra green times to the phases that suffer from higher delays during normal operations, as determined based on historical data, simulation model results, or in accordance with a priority provided by the user.

**MOE**

Measures of Effectiveness.

**MUTCD**

*Manual on Uniform Traffic Control Devices.*

**NEMA**

National Electrical Manufacturers Association.

**Non-coordinated Pre-preemption Phases**

This congestion clearance phase operates at a non-coordinated manner. Usually, the non-coordinated congestion clearance phases are assigned to turning movements on major approaches or minor movements where congestions occur.

**Non-preempted Intersection**

Intersection near an at-grade railroad crossing but has no a rail preemption mode. In Florida, the distance between a non-preempted intersection and an at-grade railroad crossing is larger than 200 feet.

**Partial Pre-preemption Phases**

A pre-preemption phase sequence containing congestion clearance phases only. Usually, the partial pre-preemption phases are implemented in the intersections near, but not next to, an at-grade railroad crossing.

**Preempted Intersection**

Intersection with a rail preemption mode. In Florida, the distance between a preempted intersection and an at-grade railroad crossing is equal to or less than 200 feet.



---

## **Preemption**

Traffic signal preemption is operated as a special mode to give the right-of-way to trains over vehicle traffic at highway intersections near highway-rail crossings.

## **Pre-preemption**

A special traffic mode that uses advance (early) train warning time to clear congested vehicle traffic before train's arrival at a at-grade railroad crossing. Pre-preemption may work cooperately with or independent of preemption.

## **SID**

Seamless Image Database.

## **Simultaneous Preemption**

A traffic signal controller and railroad active warning devices receive notification of an approaching train simultaneously.

## **SQL**

Structured Query Language.

## **TMC**

Traffic Management Center.

## **Track Clearance Phase**

A special green-time in the preemption sequences to clear vehicles that may be queued over the track.

## **TSM&O**

Transportation Systems Management and Operations

## **v/c Ratios**

Volume ÷ Capacity.

## **VAP**

Vehicle Actuated Programming, a traffic signal programming module integrated in VISSIM.

## **VISSIM**

A microscopic multimodal traffic flow simulation software package developed by PTV Planung Transport Verkehr AG in Karlsruhe, Germany.

---

**VisVAP**

An easy-to-use tool for defining the program logic of VAP signal controllers as a flow chart.

---

## **ACKNOWLEDGMENTS**

The CUTR research team is grateful for the guidance, coordination, and advice provided by Mr. Mark Plass, District Traffic Operations Engineer; Ms. Melissa Ackert, Transportation Systems Management and Operations (TSM&O) Project Manager; and her staff in the Traffic Operations Office of District 4, Florida Department of Transportation. The authors also thank Mr. Charlie Zhu, Mr. Hector Hartmann, Mr. Dan Saile, Dr. Hongyun Chen, Mr. Edward Bryant, Ms. Annette Lapkowski, and Mr. Vince Picardi for their contributions in technical support. The research team gratefully acknowledges the contribution of the Texas Transportation Institute team led by Mr. Srinivasa Sunkari and Dr. Praprut Songchitruksa in reviewing the ATMS.now manual and preparing the generic pre-preemption plan. Sincere thanks go to the team at Florida International University led by Dr. Mohammed Hadi and his researchers Dr. Yan Xiao and Mr. Xuanwu Chen for their invaluable work in data collection and simulation development. We are also very grateful to all other administrators, faculty, staff, and students at the Center for Urban Transportation Research (CUTR) at the University of South Florida who supported our efforts in this project.

---

## EXECUTIVE SUMMARY

### INTRODUCTION

A highway-railroad at-grade crossing is an intersection at which a roadway intersects a railroad on the same grade. It causes a right-of-way conflict between train traffic and vehicle traffic. The right-of-way at the crossing is always assigned to the train traffic. Once a train enters an at-grade crossing area, vehicle traffic must stop until the train leaves the crossing. Depending on train speed, train length, and traffic control type, this process may take a few minutes or much longer. During this period, both through movements at adjacent intersections and turning movements heading to the crossing are blocked. When the traffic volume is high at nearby intersections during peak periods, congestion will form at the adjacent intersections of the highway-railroad crossing.

If vehicles cannot be cleared from the track before train's arrival, severe collisions may occur between a train and the vehicles trapped on the track. On the other hand, the queue length may be longer than the storage length of the adjacent roadway intersection and extend back a considerable distance to the next access points and/or intersections, thus perhaps causing vehicle collisions. This problem is exacerbated if a second train passes before the queue from the first train clears. If at-grade crossings are near a freeway interchange, long queues may exceed ramps and intrude into freeway mainlines, thus likely inducing serious traffic accidents. In that case, an elongated queue will not only block the traffic at nearby intersections but also can result in the slowdown or full termination of the mobility of the intersection or even the entire roadway network in proximity to the railroad. Severe congestion and consequential delay may cause a failure of roadway system operations and increase negative environmental impacts.

To improve the safety and mobility of at-grade railroad crossings, the *Manual on Uniform Traffic Control Devices* (MUTCD) suggests implementation of preemption operations at signalized intersections within a distance of 200 feet of an at-grade crossing to clear vehicles from rail track areas before train's arrival. The major objective of preemption is to increase safety at these intersections by clearing vehicles from the path of trains and prevent vehicle-train accidents in railroad track areas. The track clearance time of preemption is often too short to provide "enough" clearance time for high vehicle volumes before train's arrival along an arterial intersecting rail tracks during peak periods. The impact of preemption controls on improving arterial mobility and safety in larger urban

---

areas during peak periods is limited. On the other hand, advance warning time for an approaching train in modern traffic control systems provides the potential for implementing new traffic control logics to mitigate the negative impact of train blockage on vehicle traffic. Therefore, it is necessary to use modern traffic control systems and develop effective traffic control strategies to alleviate the existing safety and mobility problems at at-grade railroad crossings and adjacent arterials in urban areas, especially during peak-hour periods.

## **RESEARCH OBJECTIVE**

The major objective of this research project was to investigate the potential and assess the benefits of using the advance features of the traffic signal system software platform ATMS.now, used prevalently in Florida, to alleviate safety and mobility problems at highway-railroad at-grade crossings and adjacent arterials.

This research aimed to develop “pre-preemption” phasing in a coordinated manner at signalized intersections along a railroad corridor. This phasing would be triggered by detection of a train entering the control section and would provide additional green time for clearance of vehicles away from grade crossings downstream from the approaching train. The additional clearance can reduce the potential for vehicle-train conflicts, especially during periods of congested arterial traffic. The concept to be considered in this research project does not require any physical or other interfaces with railroad signaling or control systems; it resides in and is implemented entirely through traffic signal system software.

This research intended to develop a generic plan that describes the process through which coordinated pre-preemption is implemented via the ATMS.now platform given the “trigger” or preemption detection at a control section “entry point.” The plan contains, but is not limited to, criteria for implementing the pre-preemption, selection of train detection technologies, estimation of train’s arrival time variance, method of phasing design and optimization, and configuration in ATMS.now and NAZTEC 2070 controllers.

## **PRE-PREEMPTION SYSTEM**

Functionally, a typical pre-preemption system has three components: detection, prediction, and control strategy.

The detection subsystem detects an approaching train at a much longer distance upstream from a railroad at-grade crossing than the classic train detection system. Many technologies

---

have been developed to detect an approaching train. Instead of installing train detectors, activation or deactivation of existing preemptions at upstream intersections along a railway corridor can be used as the trigger of pre-preemptions at the target intersections. This method becomes an attractive alternative for train detection because it does not require the installation of new devices or the application of new permissions from rail companies.

Once the detection system perceives an approaching train, the prediction subsystem starts to predict the train's arrival time at the target railroad at-grade crossing in order to activate pre-preemption at a proper time. The accuracy (error) of the train's arrival time is determined by the following factors: (1) train detection system, (2) prediction algorithm, (3) upstream detection location with respect to the target railroad crossing, and (4) train speed variance. If two or more preemptions are available at upstream crossings, the Estimated Time of Arrival (ETA) can be predicted based on the preemption logs of the upstream crossings.

The operation of the control subsystem is activated when the ETA is equal to or less than a critical value. Once the control subsystem is initialized, the normal phases at target intersections will be interrupted, and one or more pre-preemption phases will be conducted, including the following:

- Before Train's arrival (Required) – The pre-preemption system provides "extra" green time (pre-preemption phases) to critical movements at signalized intersections near the crossing before train's arrival. The "extra" green time could help clear the traffic potentially blocked during a train-passing the crossing in order to mitigate congestion during train blockage. The special phases are assigned as "conflicting" movements or a subset of them based on the optimization objectives of the pre-preemption strategy.
- During Train Blockage (Optional) – During the period of a train passing the crossing, the "conflicting" movements are blocked by a train. Thus, the general strategy is to assign green time to the movements that do not have conflicts with the train during this period.
- After Train Blockage (Optional) – After the train leaves the railroad crossing, the general strategy is to assign green time to the movements blocked by train movement for dissipating the queues that occurred in the train passing duration as soon as possible.

---

## COORDINATED PRE-PREEMPTION STRATEGY

The basic idea of the coordinated pre-preemption strategy is to assign “extra” green time to movements at several intersections along a roadway corridor that intersects a railroad before train’s arrival. The “extra” green time (congestion clearance phase) allows through traffic to be cleared on the arterial before train’s arrival. To maximize the opportunity, the “extra” green time should be coordinated at the intersections along the roadway corridor. The pre-preemption phases work at a pre-timed mode because (1) it is a requirement of coordination and (2) it can easily be coded into existing traffic controllers. Except for the coordinated pre-preemption phase, the coordinated pre-preemption strategy may provide non-coordinated pre-preemption phases for clearing other movements before train’s arrival if there is a potential for congestion due to train blockage. The phases of track clearance, dwell phases, and exit phases should be considered at the intersection next to the crossing if the storage space between the intersection and the crossing is short, even if the intersection is not preempted. An example of coordinated pre-preemption strategy is as follows:

- When pre-preemption is triggered by detecting a train approaching, the coordinated pre-preemption phase (Phase 2-6) is activated at Intersection A after a system delay.
- After a given offset (Offset A-B), the coordinated pre-preemption phase (Phase 2-6) starts at Intersection B.
- After a given offset (Offset A-C), the coordinated pre-preemption (Phase 2-6) starts at Intersection C.
- When the coordinated pre-preemption phase is completed, traffic signals at Intersections A and C go back to normal phases. When the preemption is triggered at Intersection B, the coordinated pre-preemption phase (Phase 2-6) is terminated, and the track clearance phase (Phase 1-6) is activated.
- When the train arrives at the crossing, the track clearance phase is terminated, and the dwell phases start at Intersection B at a sequence of Phase 3-7 -> Phase 4-8 -> Phase 5. Dwell phases work in an actuated manner.
- When the train leaves the crossing, dwell clearance phases are terminated, and exit phases start at Intersection B at a sequence of Phase 1-5 -> Phase 2-6.
- After the exit phase, the traffic signal at Intersection B goes back to normal phase.

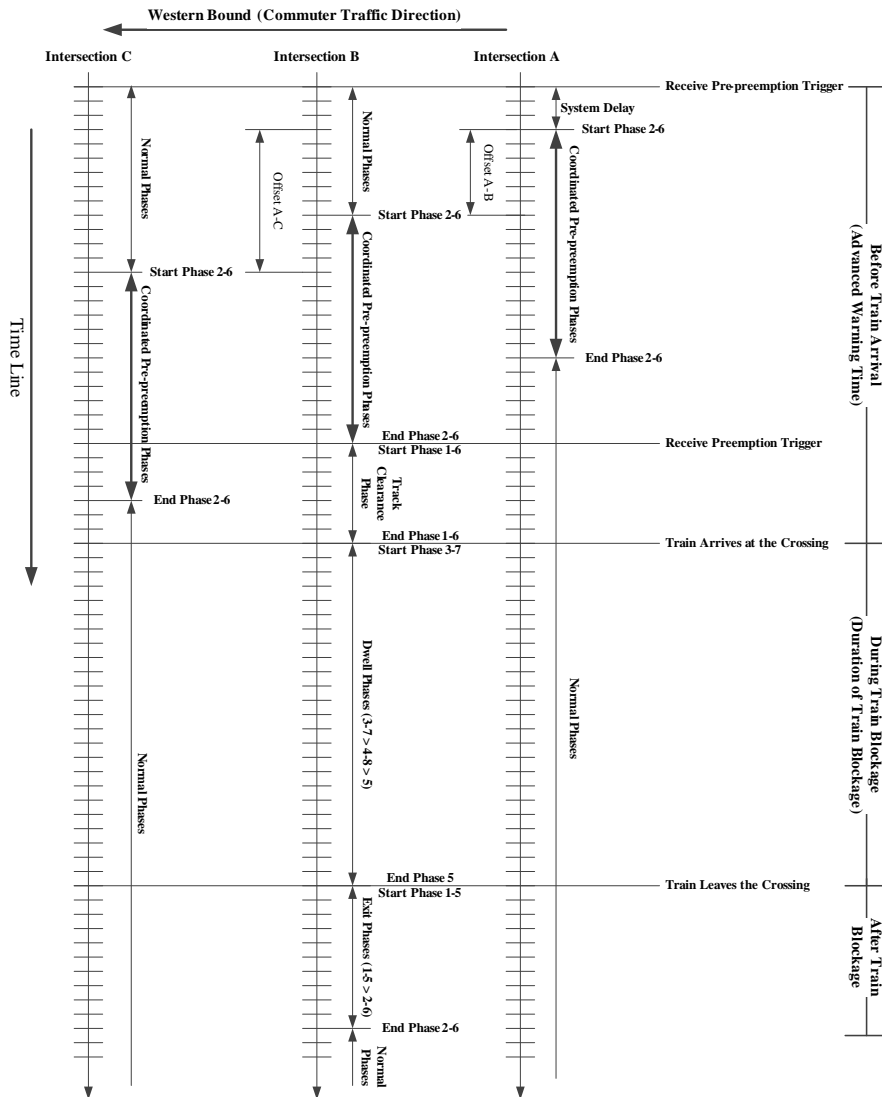
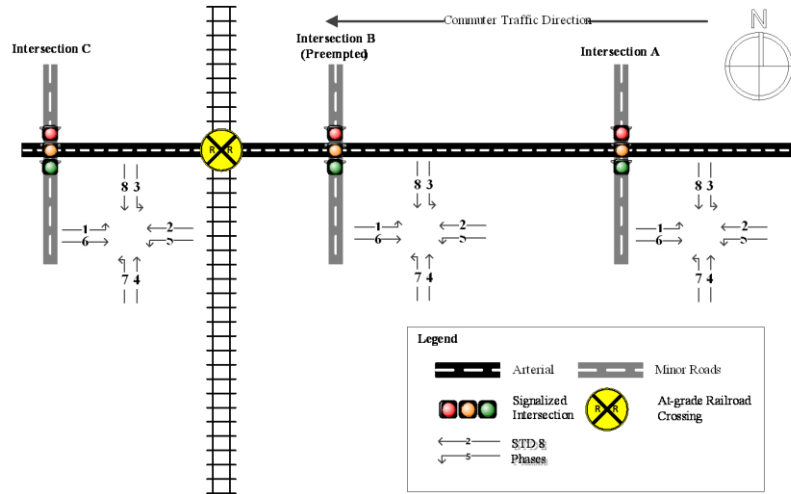
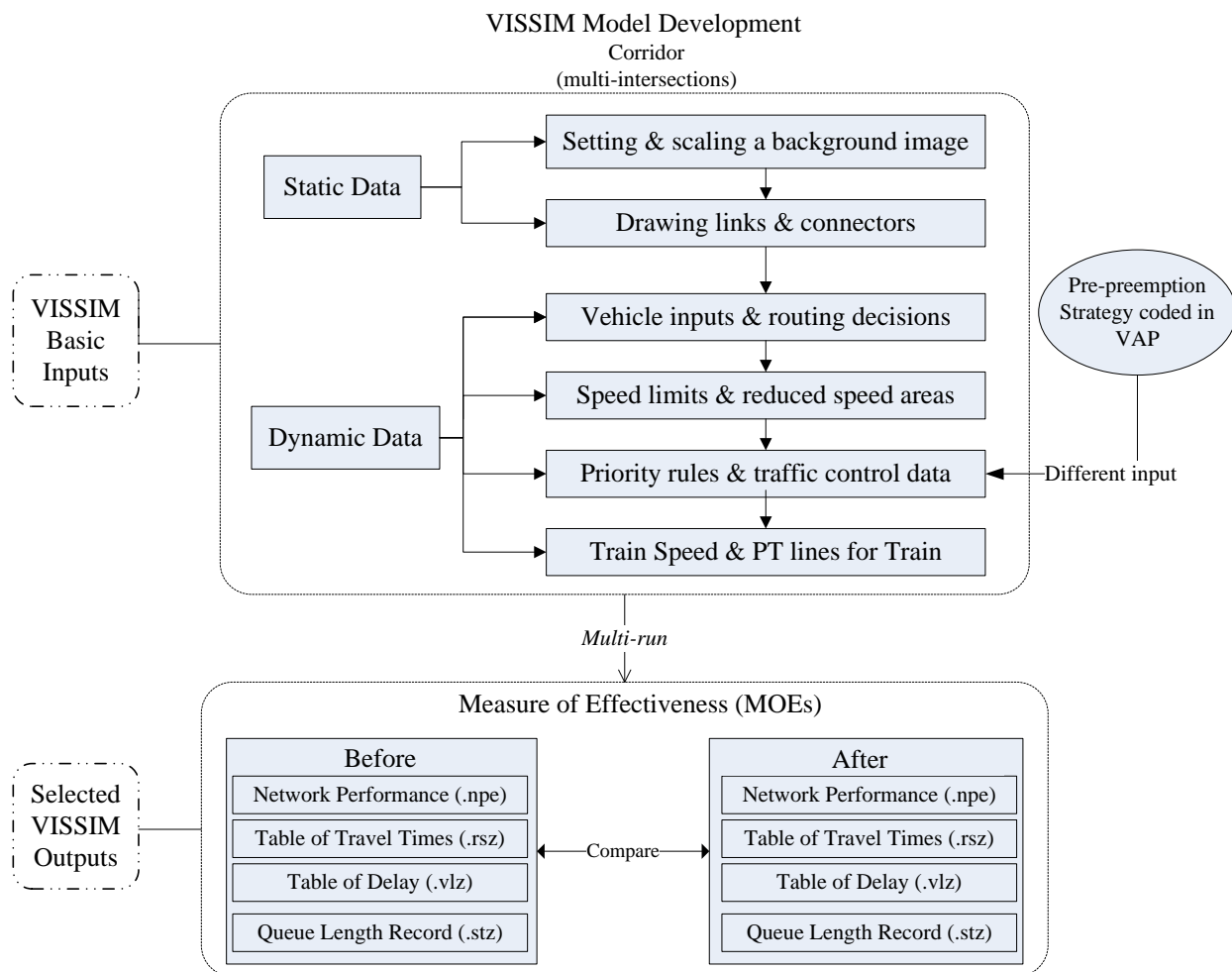

Figure ES-1 Example of Coordinated Pre-preemption Phases



## EVALUATION METHODOLOGY

VISSIM-based traffic simulation models were used to test the safety and operational performance of the proposed pre-preemption strategies. The simulation models were developed based on three control sections and were selected from the road network in Broward County, Florida. Figure ES-2 illustrates the procedure of the VISSIM-based simulation model development. In this study, all traffic signal controllers (gate controller at railroad crossings and traffic signal controller at intersections) were coded in Vehicle Actuated Programming (VAP) using the VisVAP tool. Simulation scenarios considered the factors of vehicle traffic volume, train speed (train blockage duration), and pre-preemption strategies.



**Figure ES-2 VISSIM Model-Based Development**

---

This study evaluated the safety and operational performance of the proposed pre-preemption strategy at the corridor level through a series of before-after comparisons. Average delay of the roadway corridor was used to evaluate the operational performance of the pre-preemption strategy; average stops along the corridor were used to assess the traffic smoothness, the risk of vehicle-vehicle conflicts, and environmental impacts; and averaged queue length was used to assess the congestion level of the corridor.

## **CONCLUSIONS**

Based on a comprehensive study of traffic signal pre-preemptions, close examinations of the ATMS.now software functionalities, and in-depth evaluations of various scenarios via intensive VISSIM microscopic simulation runs on two developed pre-preemption strategies, the following conclusions were obtained:

- Upstream preemption signals (activation or release) are suggested for triggering pre-preemptions at downstream intersections along the railroad corridor. The advantage of this technology is to eliminate the needs of retrieving train information from train companies or installing new train detectors. However, the technology is restricted by the availability of preemptions along the railroad corridors.
- The prediction of ETA is the key factor in implementation of pre-preemptions, which is the function of train speed and location of upstream preemptions. It can be estimated using  $ETA \text{ (in sec)} = \text{Distance between train and target (in ft)} \div \text{Train speed (in ft/sec)}$ . The accuracy of estimation of ETA is decided by the distance between train and target and the variability train travel. The variability of ETA can be estimated:  $\text{the standard deviation of ETA} = \text{the distance between train and target (ft)} \times \text{standard deviation of train travel rate (sec/ft)}$ . To reduce the estimation variability, two or more preemptions are expected at upstream crossings, and the ideal space between the two crossings is less than 0.5 miles.
- ATMS.now can produce numerous reports available for determining the impact of pre-preemption on traffic conditions, including vehicle travel time, real-time congestion, and level of service (LOS). All these reports are obtained from the LOS Hourly Day Graph. Thus, the minimum time span in ATMS.now is one hour.
- Two pre-preemption strategies were developed and tested in this study: coordinated pre-preemption and Improved Transitional Preemption Strategy (ITPS)-based pre-

---

preemption. Coordination pre-preemption aims to clear the through traffic along an arterial as much as possible before train's arrival. A coordinated phase should be included in its phase sequence. Since all pre-preemption phases are pre-timed, coordination pre-preemption is easy to implement on existing traffic controllers (e.g., NAZTEC 2070N). The ITPS-based strategy aims to reduce the number of minimum green-time abbreviations at a preempted intersection in a fully-actuated manner. Because of the complex logic of the ITPS-based strategy, its implementation may require additional logic modules.

- Based on the simulation results, the coordinated strategy can effectively improve mobility on the arterials near a railroad crossing.
  - The strategy can reduce traffic delay along the arterials by 4–60 percent, according to geometric and traffic conditions.
- The coordinated strategy can effectively improve safety on the arterials near a railroad crossing.
  - The strategy can reduce average stops along the arterials by 10–45 percent, according to geometric and traffic conditions. Lower average stop numbers can smooth traffic and reduce the risk of rear-end crashes.
  - The strategy can reduce average queue length along the commuting direction on the arterials by up to 100 percent, according to geometric and traffic conditions. Shorter queue length can reduce the risk of a queue intruding into the next intersection.
- The performance pattern of the coordinated pre-preemptions is sensitive to site features and strategy configurations.
- Considering the applicability and corridor-level performance of the pre-preemption strategy, coordinated pre-preemption is suggested when traffic volume is higher than 500 vehicles per hour per lane (vphpl) and train block duration is longer than 100 seconds.
- A generic pre-preemption plan was developed in this study to provide guidance on implementation of the pre-preemption strategy using the ATMS.now system in Florida. The generic plan provides the procedure to (1) identify the needs of pre-preemptions, (2) activate pre-preemptions using upstream preemption signals, (3) predict ETA using upstream preemptions, and (4) configure ATMS.now to implement the pre-preemption strategy.

---

## RECOMMENDATIONS FOR IMPLEMENTATIONS

Based on the conclusions, the recommendations for implementing the coordinated pre-emption strategy in Florida are given as follows.

### Train Detection and Pre-emption Trigger

As a cost-effective alternative to train detection and pre-emption trigger, upstream preemptions (hereafter, along the railway corridor) are suggested if the following conditions are satisfied:

- No other train detectors are available in the control section.
- The signalized intersections in the control section are connected to a traffic management system (such as ATMS.now).
- No train stations or other roadway facilities that interrupt train operations exist in the control section.
- At least one preempted intersection is available in the upstream from the target intersection.
- One upstream preemption signal can be used for a pre-emption trigger in the target intersection if:
  - Train speed is nearly constant in the control station at the same time of a day, and
  - Train speed pattern can be obtained from railway companies.
- Two or more upstream preempted intersections are required if:
  - Train speed variety is significant in the control section.
  - Train speed pattern is unknown.
  - Distance between the two preempted intersections is not greater than 0.5 miles.
- The distance between the upstream preempted intersection used as the pre-emption trigger and the target intersection should be less a reasonable value. The value, which is the function of train speed and its variance, can be estimated using the algorithm described in the generic pre-emption plan.

If these criteria cannot be satisfied, roadside train detectors are suggested.

---

## **Traveler Information**

ETA/ETD information can be provided to vehicle drivers through a Dynamic Message Signs (DMS).

- Two messages can be provided: the remaining time before train's arrival and the roadway blockage duration.
- The message should be given in a format of time intervals. For example, "Train will arrive in 2 – 3 minutes."
- Information can be disseminated to travelers through the FDOT SunGuide system.
  - A connection between the FDOT SunGuide and the ATMS.now is required.
  - The estimation of ETD/ETA can be developed as a new module of the FDOT SunGuide or imported from a third-party application into the SunGuide.

## **Implementation of Pre-preemption Strategy**

The coordinated pre-preemption strategy is suggested to be implemented if the following criteria are satisfied:

- Significant congestion and long queues can be observed along the urban arterial intersecting the railroad corridor.
- Train blockage duration is greater than 100 sec.
- Vehicle volume on the arterial is higher than 500 vphpl.
- Pre-preemption triggers are available in the control section.

## **Pre-preemption Timing**

- The signalized intersections along the intersecting arterial impacted by train blockage should be considered in the scope of pre-preemption coordination. The impact can be observed in the field, calculated using the queue theory, or simulated.
- The coordinated pre-preemption phase should be assigned to the commuting through-movements along the arterial.
- The non-coordinated pre-preemption phases should be considered if congestion occurs in turning movements or minor movements.
- The timing parameters (phase sequence, phase length, and phase offset) should be optimized based on traffic demand and ETA.

---

## **Implementation of Pre-preemption using ATMS.now**

- Preempt 1 in a NAZTEC 2070 controller, which has the highest priority, should be reserved for preemption operations. Preempts 3–6 can be used for pre-preemption purposes.
- The current version of ATMS.now cannot estimate ETA/ETD. Secondary software (an external process) is needed to estimate ETA and/or ETD.
- The secondary software should be allowed to access the ATMS.now database to retrieve preemption logs and write incident triggers in the ATMS.now SQL database:
  - A READ permission is required for retrieving preemption logs and monitoring Upstream Preemption (Controller Alarm #49). This access will not change any information in the database.
  - A WRITE permission is required for writing an incident trigger in Incident Trigger Table, as the trigger of pre-preemption.
- The secondary software may be developed through three ways:
  - NAZTEC will develop an internal module to implement the ETA/ETD logic in ATMS.now.
  - FDOT or its contractors will develop a third-party application, which is independent to ATMS.now, to implement the ETA/ETD logic.
  - FDOT or its contractors will develop and integrate the ETA/ETD logic in the FDOT SunGuide system.

## **Estimation of Traffic Delay using ATMS.now**

To use ATMS.now to evaluate the performance of pre-preemption strategy, traffic counts at target intersections should be imported into the ATMS.now system.

## **RECOMMENDATIONS FOR FUTURE STUDY**

- The performance of coordinated pre-preemptions is sensitive to site features and pre-preemption parameters. It is necessary to develop a simulation-based optimization procedure for optimizing pre-preemption parameters (phase types, phase sequence, phase time, and offset time) for special scenarios.

- 
- More factors, except traffic volume and train blockage duration, should be considered in future simulations to identify the impact of these factors (e.g., distance of intersection from railroad crossing, train speed variance) on the performance of the pre-preemptions. The results can be used to improve the criteria for implementing pre-preemption in the generic plan.
  - Hardware-in-loop (HIL) traffic simulation uses real traffic signal controller hardware to control simulated traffic. This simulation is done by interfacing a traffic simulation model with one or more traffic signal controllers. The traffic simulation model is a computer model of the interaction of vehicles with each other, vehicles with the roadway, and vehicles with the traffic control system. In most traffic simulation models, the traffic control system is emulated in software, but with HIL simulation, the emulated traffic control system is replaced with real traffic control hardware. In the future, an HIL system integrating ATMS.now is suggested for testing and demonstrating the performance of the pre-preemptions in an actual environment.
  - A pilot project is suggested. The purposes of the pilot project are to: (1) validate the technical feasibility and maturity for implementing pre-preemptions using ATMS.now; (2) demonstrate the implementation of pre-preemption strategies in a selected site; and (3) accumulate experience for implementing the pre-preemption strategies widely. The pilot project is suggested to include, but not limit to, the following tasks:
    - Develop the ETA/ETD estimation process (an internal module in ATMS.now, a third-party software developed a contractor, or an additional module in FDOT SunGuide)
    - Select a railway corridor which meets the pre-preemption implementation criteria.
    - Develop a site-specific pre-preemption phase timing
    - Implement a pre-preemption strategy in the selected railway corridor
    - Update the generic pre-preemption plan based on the experience collected in the pilot project.
    - Collect performance measures and evaluate the implementation of the pre-preemption strategy.

---

# Table of Contents

Disclaimer.....	ii
Metric Conversion .....	iii
Technical Report Documentation .....	iv
Glossary of Terms and Acronyms .....	v
Acknowledgments .....	x
Executive Summary .....	xi
List of Figures.....	xxvi
List of Tables.....	xxix
1 Introduction .....	1
1.1 Background.....	1
1.2 Current Implemented Rail Preemption Strategies in Florida .....	2
1.3 Problems at Highway Railroad Crossings.....	5
1.3.1 Safety Problems .....	5
1.3.2 Mobility Problems .....	6
1.3.3 Motivation .....	6
1.4 Research Objectives .....	7
1.5 Report Organization .....	9
2 Literature Review .....	10
2.1 Traffic Signal Preemption .....	10
2.1.1 Overview of Traffic Signal Preemption.....	10
2.1.2 Preemption Sequences .....	10
2.2 Traffic Signal Treatments Prior to Preemption.....	13
2.2.1 Early Warning System .....	14
2.2.2 Improved Transition Preemption Strategy .....	16
2.3 Highway-Rail Grade Crossing Safety Action Plan .....	17
3 Generic Pre-preemption Plan.....	21
3.1 Overview .....	21
3.2 Traffic Signal Pre-preemptions and Preemptions .....	21
3.3 Data Requirements for Implementing Pre-preemption .....	22
3.3.1 Railroad Lines and Signal Preemption Information .....	22
3.3.2 Railroad System-Related Information .....	23
3.3.3 Second Software .....	23
3.3.4 Detectors .....	23
3.4 Methods to Trigger Traffic Signal Pre-preemptions .....	23
3.4.1 Preemption Trigger .....	23
3.4.2 Pre-preemption Using Upstream Preemption as the Trigger .....	24



---

3.5	Procedure for Development of a Coordinated Pre-Preemption Plan.....	25
3.5.1	Applicability of Signal Pre-preemptions .....	25
3.5.2	Calculation of ETA and ETD at Target Crossings .....	26
3.5.3	Train Direction .....	26
3.5.4	Train Speed .....	27
3.5.5	Train Length .....	30
3.5.6	Train Location .....	31
3.5.7	Estimated Time of Arrival.....	31
3.5.8	Accuracy of Field Measurements .....	32
3.6	Use of ATMS.now to Implement Pre-preemption .....	33
3.6.1	Procedure.....	33
3.6.2	Limitations .....	41
3.7	Identification of Criteria for Implementing Signal Pre-preemption.....	43
3.7.1	Connection to ATMS.now .....	43
3.7.2	Gate-Down Duration .....	43
3.7.3	Traffic Characteristics.....	43
3.7.4	Expected Train Characteristics.....	44
3.7.5	Presence of Preemption Settings at Intersections .....	44
3.7.6	Distance of Intersection from Railroad Crossing .....	44
3.7.7	Intersection Mode of Operation: Coordinated, Actuated, or Pre-Timed .....	45
3.8	Optimization of Pre-preemptions .....	45
4	Developing the Method for Using ATMS.now to Report and Archive Train Delay .....	46
4.1	Congestion Levels .....	46
4.2	Incident Triggers.....	48
4.3	Summary of Report Types .....	48
5	Development of Coordinated Pre-preemption Strategy .....	50
5.1	Overview .....	50
5.2	Detection Subsystem.....	51
5.3	Prediction Subsystem .....	53
5.4	Control Subsystem.....	56
5.5	Coordinated Pre-preemption Strategy .....	58
5.6	Comparison.....	64
6	Development of Simulation Model.....	65
6.1	Site Selection .....	65
6.1.1	Selection Criteria.....	65
6.1.2	Selected Control Sections .....	65
6.2	Data Collection .....	69
6.2.1	Site Geometries .....	69

---

---

6.2.2	Traffic Data .....	70
6.2.3	Traffic Signal Data .....	70
6.2.4	Train Traffic Data.....	73
6.3	Simulation Model Development .....	74
6.3.1	Selection of Traffic Simulation Package .....	74
6.3.2	Procedure for Simulation Model Development .....	75
6.3.3	Coding Network.....	76
6.3.4	Coding Controllers .....	77
6.3.5	Create Scenarios .....	81
6.3.6	Configuring Simulation Parameters .....	82
6.3.7	Measures of Effectiveness .....	82
6.3.8	Before-After Analysis .....	84
7	Simulation Results and Discussions .....	85
7.1	Section I.....	85
7.1.1	Site Description and Scenarios .....	85
7.1.2	Simulation Results .....	90
7.1.3	Discussion .....	92
7.2	Section II.....	93
7.2.1	Site Description and Scenarios .....	93
7.2.2	Simulation Results .....	101
7.2.3	Discussion .....	104
7.3	Section III .....	106
7.3.1	Site and Scenarios .....	106
7.3.2	Simulation Results .....	114
7.4	Summary.....	117
8	Conclusions and Recommendations.....	119
8.1	Summary and Conclusions.....	119
8.2	Recommendations for Implementation .....	121
8.3	Recommendations for Future Study .....	123
	Bibliography .....	126
	Appendix: Case Study to Predict Onset and Removal of Preemptions .....	127

---

## LIST OF FIGURES

Figure ES-1	Example of Coordinated Pre-preemption Phases .....	xv
Figure ES-2	VISSIM Model-Based Development .....	xvi
Figure 1-1	Florida Rail Network .....	2
Figure 1-2	Vehicle Delay Due to Train Blockage .....	3
Figure 1-3	Example of Simultaneous Preemption and Advance Preemption Time Line for Same Railroad Gate Crossing .....	5
Figure 2-1	Preemption Sequence .....	11
Figure 2-2	Early Warning System Phases and Sequence .....	15
Figure 2-3	ITPS Logic Sequence.....	18
Figure 2-4	Countermeasures of Railroad Crossing Crashes from Highway-Rail Grade Crossing Safety Action Plan .....	20
Figure 3-1	Sample Rail and Highway Corridor .....	27
Figure 3-2	Train Average Speed Calculation .....	28
Figure 3-3	Continuation of Average Speed Calculation .....	29
Figure 3-4	Average Speed Calculation Using Release of Preemption at Successive Grade Crossings .....	30
Figure 3-5	Calculation of Train Length .....	31
Figure 3-6	Flow Chart for Use of ATMS.now to Implement Pre-Preemption Strategies .	35
Figure 3-7	View of Max-out Counter .....	36
Figure 3-8	Process to Select Viewing Controller Status .....	36
Figure 3-9	Creation of Alarm to Monitor Preempt 1 in ATMS.now .....	37
Figure 3-10	Designation of Preempts for Different Objectives .....	38
Figure 3-11	Creation of a Pre-Preemption Trigger .....	39
Figure 3-12	Programming Preempts (Part 1) .....	40
Figure 3-13	Programming Preempts (Part 2) .....	40
Figure 4-1	Congestion Level Definitions in ATMS.now.....	47
Figure 4-2	Real-Time Congestion Data Report.....	49
Figure 5-1	Pre-preemption System Architecture .....	51
Figure 5-2	Train Speed Calculation Based on Two Upstream Preemptions .....	54
Figure 5-3	Calculation of Available Time for Pre-preemption .....	55
Figure 5-4	Train Length Calculation Based on Upstream Preemptions .....	56
Figure 5-5	Example Site for Pre-preemption Strategy .....	60
Figure 5-6	Pre-preemption Timeline (one coordinated pre-preemption phase at Intersection B).....	61
Figure 5-7	Pre-preemption Time Line (two coordinated pre-preemption phases at Intersection B).....	62

---

Figure 5-8	Pre-preemption Timeline (one non-coordinated phase and one coordinated phase at Intersection B) .....	63
Figure 6-1	Control Sections in Broward County, Florida .....	67
Figure 6-2	Example of Intersection Movement Counts .....	71
Figure 6-3	Example of Actuated Traffic Signal Timing Form.....	72
Figure 6-4	Example of Coordination Timing Form .....	73
Figure 6-5	Example of Preemption Log .....	74
Figure 6-6	Procedure of VISSIM-Based Simulation Model Development .....	75
Figure 6-7	Logic of Crossing Gate Controller in VISSIM .....	78
Figure 6-8	Pre-preemption Logic for Preempted Intersection Coded in VISSIM.....	79
Figure 6-9	Pre-preemption Logic for Non-Preempted Intersection Next to a Crossing Coded in VISSIM .....	80
Figure 6-10	Pre-preemption Logic for Intersection Not Next to a Crossing Coded in VISSIM .....	81
Figure 7-1	Tested Intersections in Section I.....	86
Figure 7-2	Timeline of Pre-preemption Strategy I (After 1) .....	87
Figure 7-3	Timeline of Pre-preemption Strategy I (After 2) .....	88
Figure 7-4	Average Delay in Section I.....	90
Figure 7-5	Average Stops in Section I.....	91
Figure 7-6	Average Delay Reduction after Implementing Pre-preemption (After 1) .....	92
Figure 7-7	Average Stops Reduction after Implementing Pre-preemption Strategy (After 1) .....	93
Figure 7-8	Layout of Tested Intersections in Section II.....	94
Figure 7-9	Pre-preemption Strategy - After 1 .....	96
Figure 7-10	Pre-preemption Strategy - After 2 .....	97
Figure 7-11	Pre-preemption Strategy - After 3 .....	98
Figure 7-12	Pre-preemption Strategy - After 4 .....	99
Figure 7-13	Average Delay in Section II .....	101
Figure 7-14	Average Stops in Section II .....	102
Figure 7-15	Average Queue Length along Oakland Park Blvd (Westbound) .....	103
Figure 7-16	Average Delay Reduction along Oakland Park Blvd (Westbound) .....	104
Figure 7-17	Average Stops Reduction along Oakland Park Blvd (Westbound) .....	105
Figure 7-18	Average Queue Length Reduction along Oakland Park Blvd (Westbound) ..	105
Figure 7-19	Layout of W. Commercial Boulevard with CSX Rail Corridor .....	106
Figure 7-20	Phasing Diagram of I-95 Interchange at W. Commercial Boulevard.....	107
Figure 7-21	Locations of Two Upstream Intersections along CSX Rail Corridor Relative to Target Intersection .....	108
Figure 7-22	Current Delays by Approaches at Target Intersection.....	109

---

---

Figure 7-23	Logic Algorithm of Modified ITPS Pre-Preemption Strategy When Current Phase Is Phase 1 .....	111
Figure 7-24	Logic Algorithm of Modified ITPS Pre-Preemption Strategy When Current Phase Is Phase 12 .....	112
Figure 7-25	Logic Algorithm of Modified ITPS Pre-Preemption Strategy When Current Phase Is Phase 3, 4, 5, or 6 .....	112
Figure 7-26	Signal Phase Logic of Potential Simplified Pre-Preemption Strategies.....	113
Figure 7-27	Average Intersection Delays by Scenarios .....	116

---

## LIST OF TABLES

Table 2-1	Florida Crossing Incidents.....	19
Table 5-1	Train Detection Technologies .....	52
Table 5-2	Summary of Pre-preemption Strategies .....	64
Table 6-1	Summary of Control Section I .....	66
Table 6-2	Summary of Control Section II .....	68
Table 6-3	Summary of Control Section III.....	69
Table 6-4	Data Collection at Control Sections .....	70
Table 6-5	Traffic Controllers Coded in VISSIM.....	78
Table 6-6	Selected MOEs in Simulation .....	83
Table 6-7	Example of a MOE Output Table (Average Delay, seconds per vehicle) .....	83
Table 7-1	Vehicle Traffic Volume on W Broward Blvd (Westbound) .....	89
Table 7-2	Levels of Train Duration (Train Speed) on W Broward .....	89
Table 7-3	Commuter Vehicle Traffic Volume on Oakland Park Blvd.....	100
Table 7-4	Levels of Train Duration (Train Speed) in Section II.....	100
Table 7-5	Departure Time of NB Trains.....	115
Table 7-6	Number of Average Minimum Green-Time Abbreviations for 10 Runs* .....	116
Table 7-7	Comparison of Pre-preemption Strategies .....	118
Table A-1	Median Preemption and Link Travel Time for Northbound Direction for SFR Corridor .....	127
Table A-2	Example of Preemption Activity for Northbound Train in SFR Corridor .....	127
Table A-3	Example of Prediction of Preemption Activities Based on Historical Data and Corrections Based on Real-Time Data.....	128

---

# **1 INTRODUCTION**

## **1.1 Background**

According to statistics compiled by the Federal Railroad Administration (FRA), Florida experienced a high number of train-vehicle crashes between 2006 and 2008 in comparison with other states. FRA required Florida to submit a Highway-Rail Grade Crossing Safety Action Plan for reducing crashes at railroad crossings by increasing public awareness, constructing roadway overpasses, increasing the number of lights and gates at crossings throughout the state, and implementing other means.

In South Florida, two major rail lines (South Florida Rail Corridor and Florida East Coast Railway) stretch across the region, impacting every minor and major east-west arterial, as shown in Figure 1-1. The South Florida Rail Corridor includes three types of rail traffic—commuter rail (Tri-Rail), intercity passenger rail (Amtrak), and freight rail operations (CSX)—while the Florida East Coast (FEC) Railway is exclusively freight rail operations. Although some information about their safety impacts is known, their mobility impacts are not measured or tracked regularly. The Florida Department of Transportation (FDOT) District 4's Transportation System Management and Operation (TSM&O) pilot network (initial deployments in Fort Lauderdale and southern Broward County) will use technology to measure, report, and use network performance measures to enhance mobility on the TSM&O network. To understand and develop solutions that enhance the network's performance, TSM&O operators must understand the causes of delay and develop strategies that include operational improvements and information dissemination to users that allows them to make better decisions on which route or mode to take on the network. Reliable and real-time performance measures relating to train crossing delays will give operators opportunities to develop and implement strategies that minimize congestion resulting from at-grade highway-railroad crossings.

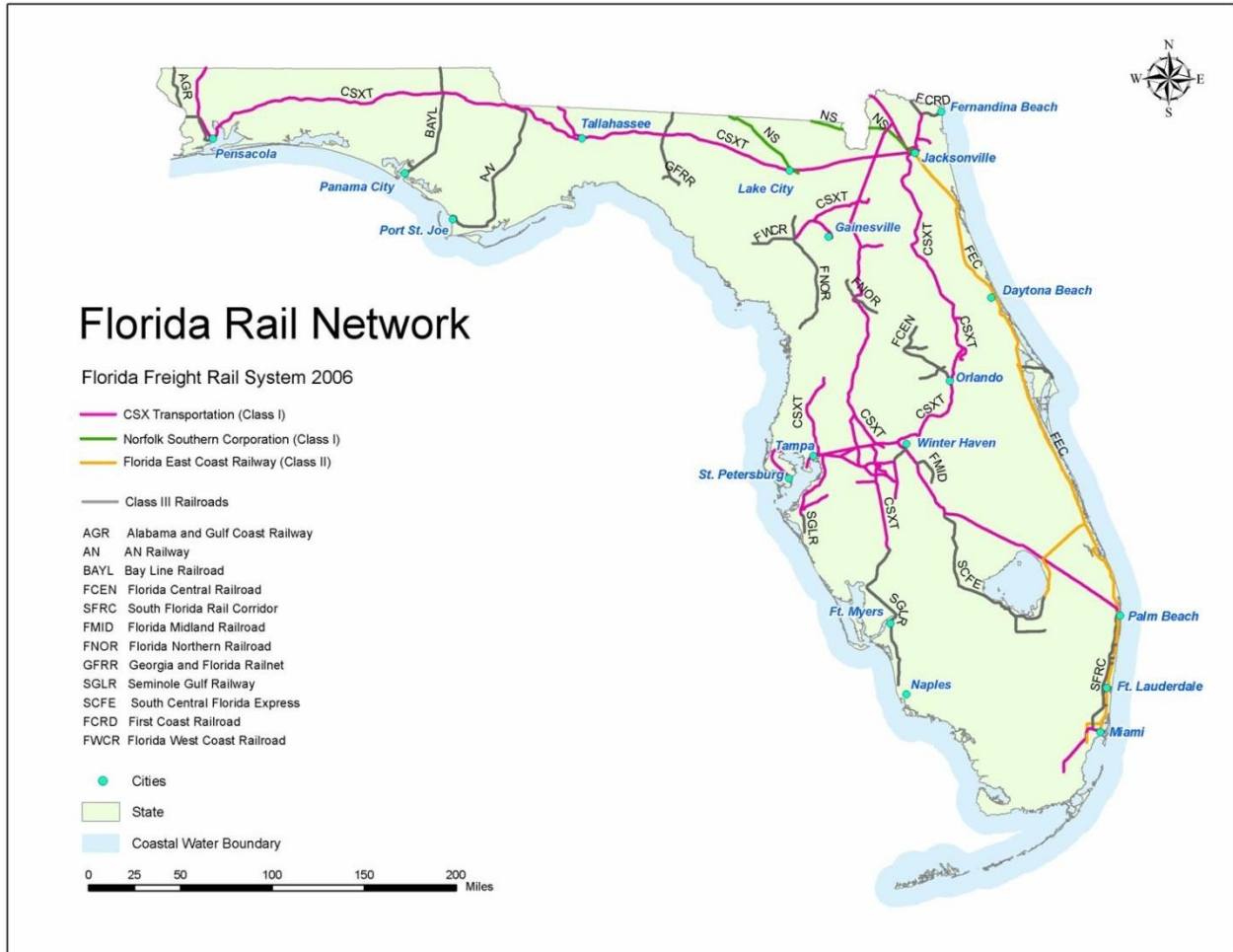

Source: FDOT Website

**Figure 1-1 Florida Rail Network**

## 1.2 Current Implemented Rail Preemption Strategies in Florida

Florida rail transportation, consisting of more than 2,700 miles of track routes, serves as an important transportation system in Florida, with its continuing population growth and rapidly-diversifying economy. Railroad preemption is an important strategy to provide safe vehicular, pedestrian, and train movements and to complement these three modes. The *Manual of Uniform Traffic Control Devices* (MUTCD) (Federal Highway Administration, 2009) states that

where a signalized highway intersection exists in close proximity to a railroad crossing, the railroad signal control equipment and the traffic signal control equipment should be interconnected, and the normal operation of the traffic



---

signals controlling the intersection should be preempted to operate in a special control mode when trains are approaching.

The MUTCD suggests that a traffic control signal should be provided with preemption when a highway-rail grade crossing is equipped with a flashing-light signal system and is located within 200 feet of an intersection or midblock location controlled by a traffic control signal. Florida recommends signal preemptions at intersections located 200–500 feet upstream of the railroad grade crossing with warning devices (Long, 2002).

Traffic signal preemption is the transfer of the normal operation of a traffic control signal to a special control mode of operation. Preemption at at-grade rail crossings has a significant impact on safety and mobility, as it may cause significant vehicle delays at the railroad crossing or the adjacent intersections, as shown in Figure 1-2. A pre-preemption strategy might help reduce the delay by quickly clearing the vehicles before the track clearance.



**Figure 1-2 Vehicle Delay Due to Train Blockage**

Simultaneous preemption and advance preemption are two types of railroad preemptions in practice. Simultaneous preemption is designed so that the traffic signal controller unit and the railroad active warning devices (flashing lights and gates) receive the notification of an approaching train simultaneously. Simultaneous preemption is typically used where the minimum warning time needed for the operation of the railroad active warning devices is

---

sufficiently long enough to clear stationary vehicles safely out of the crossing. By law (Traffic Engineering Council Committee, 2003), railroad companies are required to provide traffic agencies with at least 20 seconds of advance warning of the train's impending arrival at the grade crossing. However, most railroads try to provide traffic agencies with approximately 25 seconds of advance warning for simultaneous preemption. Additional warning time (i.e., more than the required 20 seconds) can be requested from the railroad to provide advance preemption; however, because of costs, this is not done at most highway-grade crossings.

When the signal controller unit needs to receive notification earlier than the activation of railroad warning devices, advance preemption is used. According to an Institute of Transportation Engineers' (ITE) recommendation, advance simulations should be used if the simultaneous preemption does not have enough delay and clearance time between the lowering of the gates and the movement of vehicles within the minimum track clearance distance (Venglar et al., 2000). Figure 1-3 shows an example of the timelines for the 20-second warning for both simultaneous railroad preemption and advance railroad preemption (Ruback et al., 2007). The timeline includes total warning time, light flashing time, gate action time, signal time, and queue clearance time. These two types of preemption require different traffic signal control plans, schedules, and applicable situations. As shown in Figure 1-3, advance preemption has longer maximum right-of-way transfer time (RTT) than the simultaneous preemption plan for the signal plan. RTT is the maximum amount of time needed prior to display of the clear-track green interval. This time includes the remaining time of the active green phase, pedestrian walk and clearance, and yellow change and red clearance interval for opposing movements.

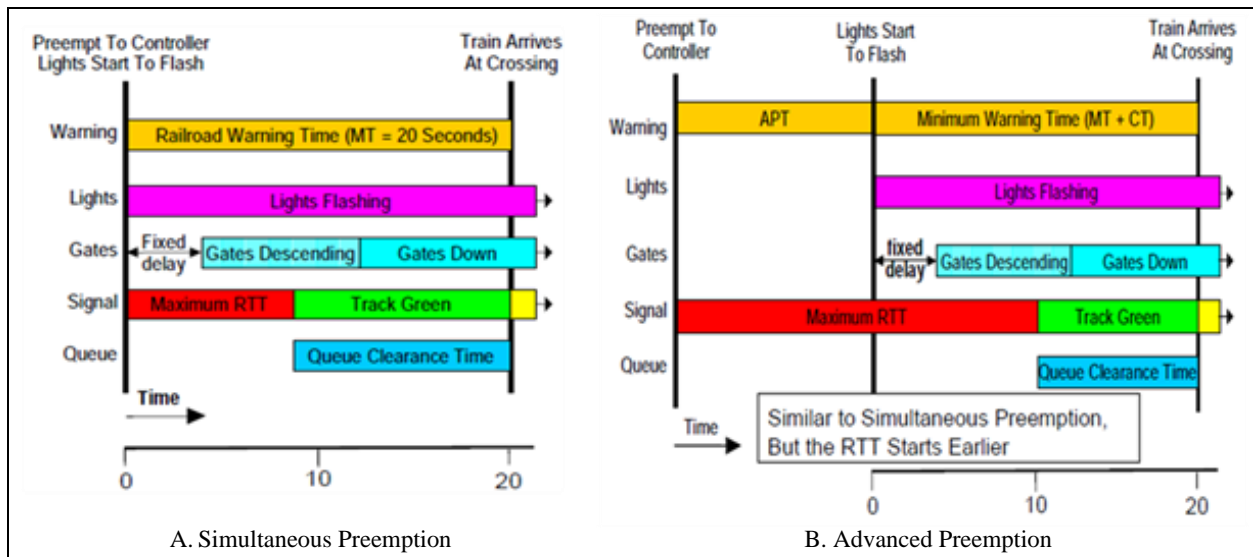

**Figure 1-3 Example of Simultaneous Preemption and Advance Preemption Time Line for Same Railroad Gate Crossing**

### 1.3 Problems at Highway Railroad Crossings

#### 1.3.1 Safety Problems

A highway-railroad at-grade crossing is an intersection at which a roadway intersects a railroad at the same grade. It causes a right-of-way conflict between train traffic and vehicle traffic. Since it is difficult for a train to fully stop and accelerate again to leave the crossing, the right-of-way at a crossing is always assigned to the train traffic. The railroad company is responsible for sensing the approaching train and activating the warning devices to prevent vehicles from entering into the crossing area during a train passing the crossing. Highway traffic control operations are independent of railway control operations. When a roadway intersection is closed at the crossing, vehicles approaching the intersection from the crossing may face a red signal, and a queue may back up across the at-grade railroad crossing. If vehicle traffic at the crossing area is not cleared from the track before train's arrival, severe injuries and even fatalities of vehicle drivers and passengers can result from collisions between the train and a vehicle.

When at-grade railroad crossings are located on an urban arterial, which usually serves as a daily commuting route with high vehicle traffic volume during peak periods, a train passing the crossing will block the vehicle traffic and cause the formation of a long vehicle queue along the arterial. If train blockage duration is sufficiently long, the queue length may be longer than the storage length of the adjacent roadway intersection and extend back a

---

considerable distance to the next access points and/or intersections, thus slowing all movement, blocking traffic, and perhaps causing vehicle collisions. This problem is exacerbated if a second train passes before the queue from the first train clears. If at-grade crossings are near a freeway interchange, long queues may exceed ramps and intrude into freeway mainlines, thus inducing serious traffic accidents.

### 1.3.2 Mobility Problems

Once a train enters an at-grade crossing area, the right-of-way of the crossing is given to the train. Vehicle traffic must stop until the train leaves the crossing. Depending on train speed, train length, and traffic control type, this process may take a few minutes or much longer. During this period, both through movements at adjacent intersections are blocked, as are turning movements heading to the crossing. When the traffic volume is high at nearby intersections during peak periods, long queues will form at adjacent intersections, and vehicles do not have sufficient time to get through the crossing and must wait in the queue until the train leaves. In that case, an elongated queue will not only block the traffic at nearby intersections, but also will result in the slowdown or full termination of the mobility of the intersection, or even the entire roadway network in proximity to the railroad. Severe congestion and consequential delay may cause a failure of roadway system operations and increase negative environmental impacts.

### 1.3.3 Motivation

To improve the safety and mobility of at-grade railroad crossings, the MUTCD suggests implementation of preemption operations at signalized intersections within 200 feet of an at-grade crossing to clear vehicles from rail track areas before train's arrival. However, the major objective of preemption is to prevent vehicle-train accidents in railroad track areas. Preemption's track clearance time is much shorter for clearing high vehicle volumes along an arterial intersecting rail tracks during peak periods. The impact of preemption controls on improving arterial mobility and safety in larger urban areas during peak periods is limited. On the other hand, advance warning time for a train approaching in modern traffic control systems provides the potential for implementing new traffic control logics to mitigate the negative impact of train blockage on vehicle traffic. Therefore, it is desirable to develop an effective traffic control strategy for resolving the existing safety and mobility problems at at-grade railroad crossings and adjacent arterials in urban areas, especially during peak periods.

---

## 1.4 Research Objectives

The major objective of this research project was to investigate the potential for and assess the benefits of using advance features of a traffic signal system software platform (ATMS.now), use of which is prevalent in Florida, to alleviate safety and mobility problems at highway-railroad at-grade crossings and adjacent arterials.

This research developed “pre-preemption” phasing in a coordinated manner at signalized intersections along a railroad corridor. This phasing would be triggered by detection of a train entering the control section and would provide additional green time for clearance of vehicles away from grade crossings downstream from the approaching train. The additional clearance can reduce the potential for vehicle-train conflicts, especially during periods of congested arterial traffic. The concept considered in this research project does not require any physical or other interfaces with railroad signaling or control systems; it resides in and is implemented entirely through traffic signal system software. The research also took into consideration the impacts of diverse rail operations.

This research investigated the use of signal system software to estimate the location of trains, train speed, and impacts on travel time or the predicted delay an incoming train will have on intersecting arterials.

Additionally, this research provides guidance on how TSM&O operators should use this information to develop signal timing patterns that optimize travel times on parallel routes or potential detour routes the users may take to avoid the delay.

The following tasks and activities were conducted in this study:

- **Understanding Current Implemented Rail Preemption Strategies in Florida**

The understanding and knowledge of current implemented railroad preemption types helped to determine the prevailing railroad preemption type, the advantages and disadvantages of each type, the applicable conditions, and how this project could be compatible with regional and state railroad preemption plans. In addition, due to different traffic signal software platforms used in different regions in Florida, how the developed strategy can be applicable to these software packages can help other regional agencies to potentially implement the railroad pre-preemption strategy.

---

- **Development of a Coordinated Pre-Preemption Plan for Implementation via the ATMS.now Platform**

This research developed a plan that describes the process through which coordinated pre-preemption is implemented via the ATMS.now platform given the “trigger” or preemption detection at a control section “entry point.” The plan contains but is not limited to criteria for implementing pre-preemption, selection of train detection technologies, estimation of train’s arrival time variance, method of phasing design and optimization, and configuration in ATMS.now and NAZTEC 2070 controllers.

- **Development of Strategies for Optimizing Signal Operations for Adjacent Arterials**

This study developed a strategy for optimizing signal operations before, during, and after a train passing a highway-railroad at-grade crossing at intersections along intersecting arterials at a coordinated manner to maximize network performance. To develop strategies for optimizing signal operations, signal timing and phasing parameters were selected based on a full understanding of the mobility and safety issues at each location for each time of day. Three phases were included for developing the strategies: prior to train’s arrival, during train passing, and after train.

- **Developing and Implementing a Method to Predict Train Performance**

This research investigated the use of the ATMS.now software and any other existing FDOT resources to estimate train performance, including train speed, train length, train delay, train activities, etc.

- **Development of a Method for Estimating the Strategy-related Mobility and Safety Impacts within the Identified Control Section**

To evaluate the effectiveness of the proposed strategies developed from this research project, a methodology was developed for estimating the strategy-related mobility and safety impacts within the identified control section, including at signalized intersections adjacent to the signalized intersections at the control section’s grade crossings. Adjacent intersections include the signalized intersections impacted by the railroad crossing along the arterials intersecting the railroad. The methodology allows comparison of different strategies on the basis of their effect on overall delay within the network consisting of the grade crossing and adjacent signalized intersections. Using this methodology, researchers were able to evaluate and report the estimated mobility and safety impacts to the adjacent intersections.

---

## **1.5 Report Organization**

The report is organized as follows: Chapter 2 is a summary of the literature review. A comprehensive plan to guide implementation of the pre-preemption is described in Chapter 3. Chapter 4 provides the method to report train delay using ATMS.now. Chapter 5 describes the pre-preemption strategy developed in this study. Chapter 6 illustrates the simulation experiment, including selection of control sections, data collection, controller development, and simulation procedure. The simulation result is presented and discussed in Chapter 7. Chapter 8 summarizes the findings of this study, the recommendations for implementations, and the recommendations for future study. The Appendix demonstrates a case study to predict the onset and removal of preemptions.

---

## 2 LITERATURE REVIEW

This chapter summarizes previous studies and existing technologies related to traffic signal operations at intersections adjacent to highway-railroad crossings. The following are included:

- Traffic Signal Preemption
- Existing Signal Treatment Prior to Preemption
- Train Detector Technologies
- Microscopic Traffic Simulation Models
- Highway-Rail Grade Crossing Safety Action Plan

### 2.1 Traffic Signal Preemption

#### 2.1.1 Overview of Traffic Signal Preemption

Traffic signal preemption is operated at a special mode to give the right-of-way to trains over vehicle traffic at highway intersections near highway-rail crossings. It is commonly used to clear vehicles that may be in danger of being hit by a train before it arrives at a crossing. A properly-designed traffic signal preemption system aims to increase the safety and mobility of arterials (Federal Highway Administration, 2009).

The need for preemption at signalized roadway intersections that were close to a highway-railroad intersection was raised in "Preemption of Traffic Signals At or Near Railroad Grade Crossings with Active Warning Devices: A Recommended Practice," published by ITE in 1979 and updated in 1997. The MUTCD provides guidance and standards for the preemption of traffic control signals and how to transition into and out of preemption. The key signal aspect requires that at a signalized intersection that is located within 200 feet of a highway-rail grade crossing (measured from the edge of the track to the edge of the roadway, where the intersection traffic control signals are preempted by the approach of a train), all existing turning movements toward the highway-rail grade crossing should be prohibited during the signal preemption sequences.

#### 2.1.2 Preemption Sequences

Figure 2-1 shows a typical preemption sequence: right-of-way transfer, track clearance, dwell phase, and exit phase.



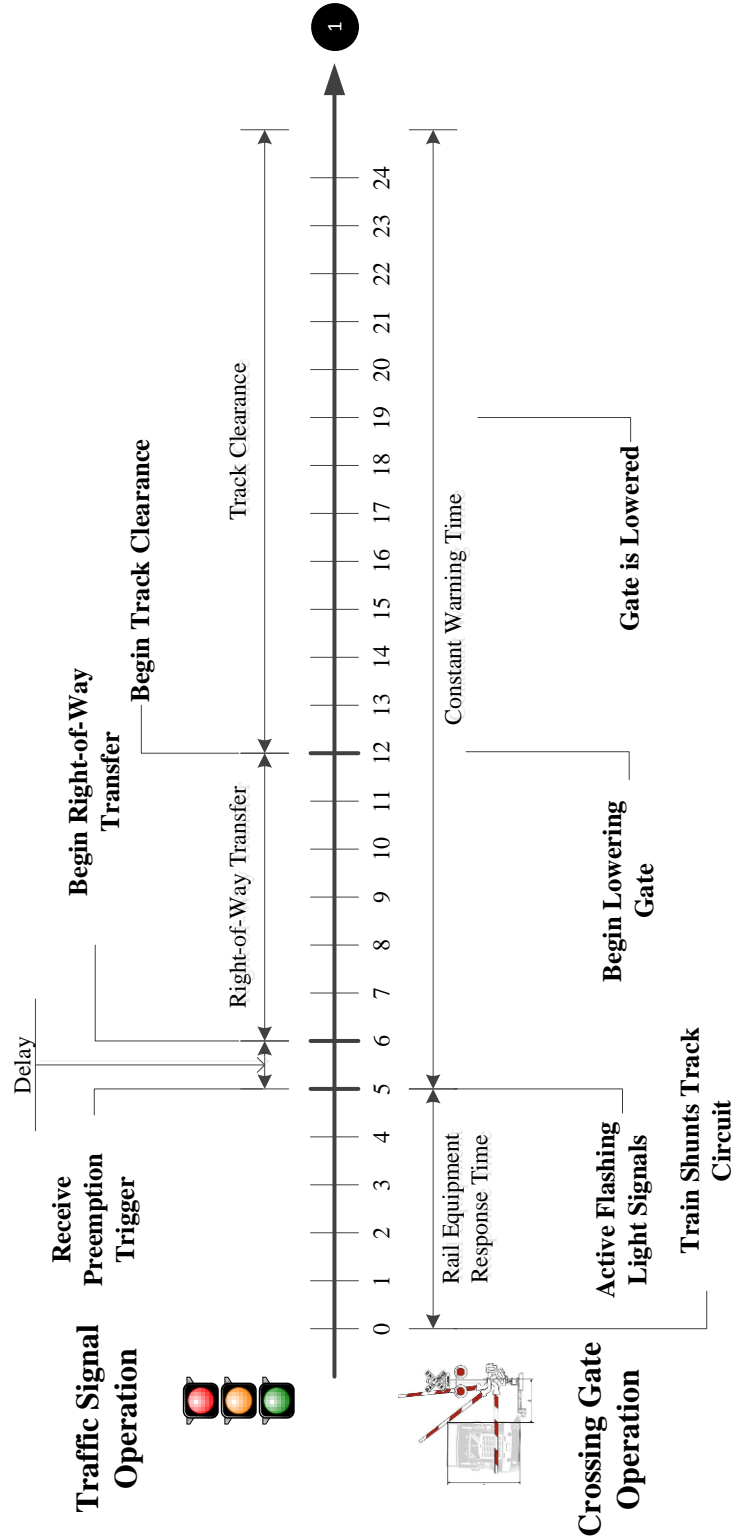

**Figure 2-1 Preemption Sequence**

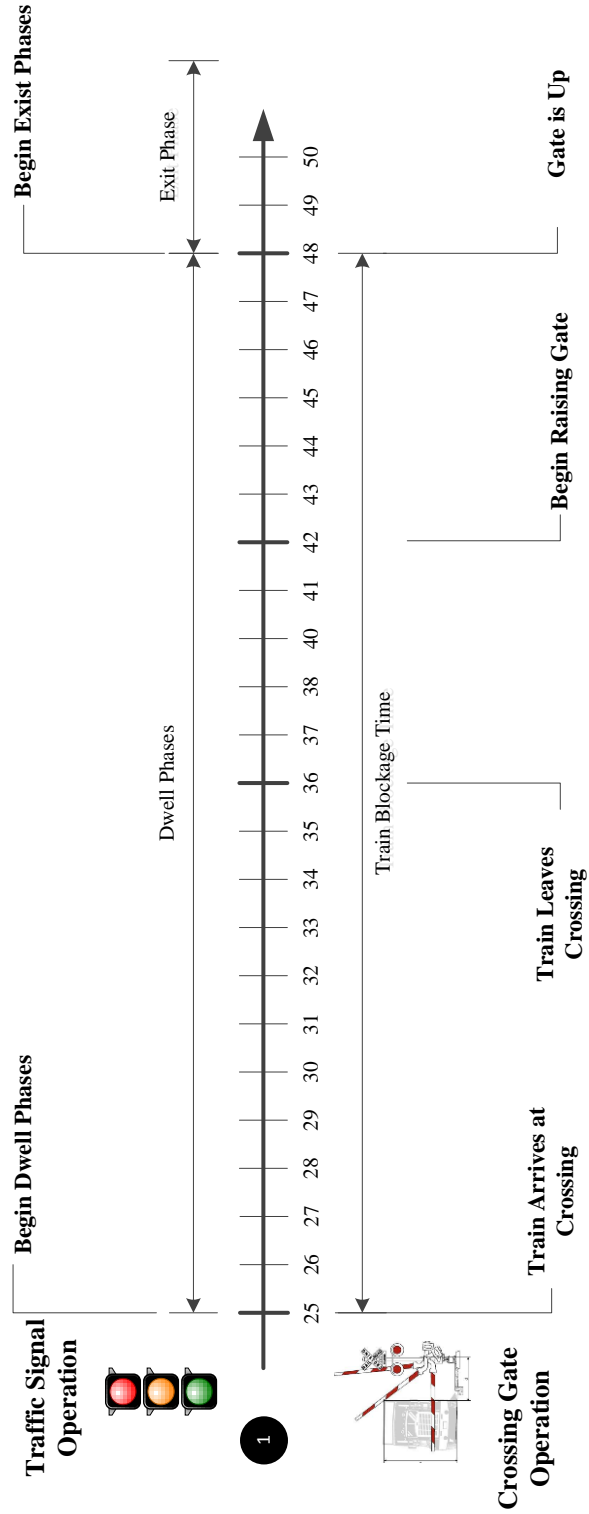

**Figure 2-1 (cont'd) Preemption Sequence**

---

## **Right-of-Way Transfer**

The initiation of preemption is triggered upon the detection of an approaching train. In some circumstances, a pre-determined delay is programmed into the preemption sequence that allows controllers to postpone the initiation of the preemption plan after detecting the incoming train. The transition of preemption can occur at any point in a traffic signal's normal cycle of operation. Therefore, before entering into the track clearance phase, enough time must be provided to terminate any active phase at any point in the cycle; otherwise, the current phase must be extended to terminate the active phase safely. In this case, minimum green times, vehicle change and clearance times (yellow + all red), and pedestrian clearance times must all be considered.

## **Track Clearance**

After the normal operation phase has been terminated safely, a track clearance time is provided to clear the remaining traffic that may be queued over the track or is in danger of being hit by the train before the train arrives at the crossing. The track clearance time must be long enough to clear all vehicles within the limits of the crossing and is associated with vehicle characteristics, geometry of the crossing, and the distance between the intersection and the crossing.

## **Dwell Phase**

A dwell phase is provided after the track clearance phase when the train is near or in the crossing. It must be kept active until the train has left the detection area and cleared the crossing. During this time, no other traffic can cross the track and must stop within the limits of the crossing. The MUTCD suggests that certain vehicle movements that do not cross the track are permitted. Alternatively, vehicle movements that do not conflict with the train movement can be operated during the dwell phase.

## **Exit Phase**

After the train leaves the crossing and exits the detection zone, the traffic signal needs to transition out of preemption and back into the normal operation cycle. Usually, green signals are assigned to the movements blocked by trains before entering the normal signal sequence.

## **2.2 Traffic Signal Treatments Prior to Preemption**

With the development of train detection technologies, modern traffic control systems may provide advance warning time, which is much earlier than a normal warning time (20–25 s)

---

for an approaching train. Advance warning time allows the potential to optimize traffic signal operations at the intersections near at-grade railroad crossings before preemption to reduce congestion and make phase transition smooth. Currently, two major traffic control strategies have been developed: Early Warning System and Transition Preemption Strategy.

### 2.2.1 Early Warning System

The Early Warning System (EWS) was designed to address taking action before a train arrives at a highway-railroad crossing to mitigate the congestion after the train passes (Roberts and Brown-Esplain, 2005). Its basic idea is to assign "additional" green time to traffic movements conflicting with train passing before train's arrival, taking time from other movements. The EWS concept has the following features (Roberts and Brown-Esplain, 2005):

- Simple and inexpensive to design, build, and install
- Capable of being maintained by existing maintenance technicians with little or no new training required
- Controlled by the highway agency without need for any changes to the railroad control system
- Able to maintain the time-tested safety aspects of current at-grade crossing highway and railroad control schemes

A typical EWS has the following components (Roberts and Brown-Esplain, 2005):

- Detection – The EWS detects an approaching train at a much longer distance from the target at-grade railroad crossing. The selectable detection technologies include Rader Detection and Time Domain Reflectometry Detection.
- Prediction – The EWS predicts the time that the train would arrive at the crossing and the time interval before clearing the crossing based on data collected by the detection system. The prediction algorithm can be simple (assuming constant train speed) or sophisticated (train speed in variance).
- Traffic Control – The EWS interrupts the normal traffic signal cycle and allocates green time to the movements that would be blocked by a train passing the crossing before the train arrives. The "additional" green time is "borrowed" from the movements that will not be blocked by the train. As the result, this strategy reduces the delay and minimizes accidents for movements that receive "additional" green time, but the delay may be increased for the movements from which the green time is "borrowed."

A major advantage of the EWS is that this logic can be coded into prevailing traffic signal controllers, such as NEMA TS-2 or 2070. Modern controllers provide six or more standard preemptions with different priorities. The highest preemption (Preemption 1) is always linked to the standard preemption operation. The EWS algorithm assigns lower preemptions to each leg that conflicts train traffic. As shown in Figure 2-2, a four-leg intersection requires three preemptions to implement the EWS. The EWS triggers one of them (Preemption 6) to start the EWS for one leg at a pre-timed operation. When this preemption has completed, the next lower preemption will be called for the next leg. This step continues until the last leg is timed.

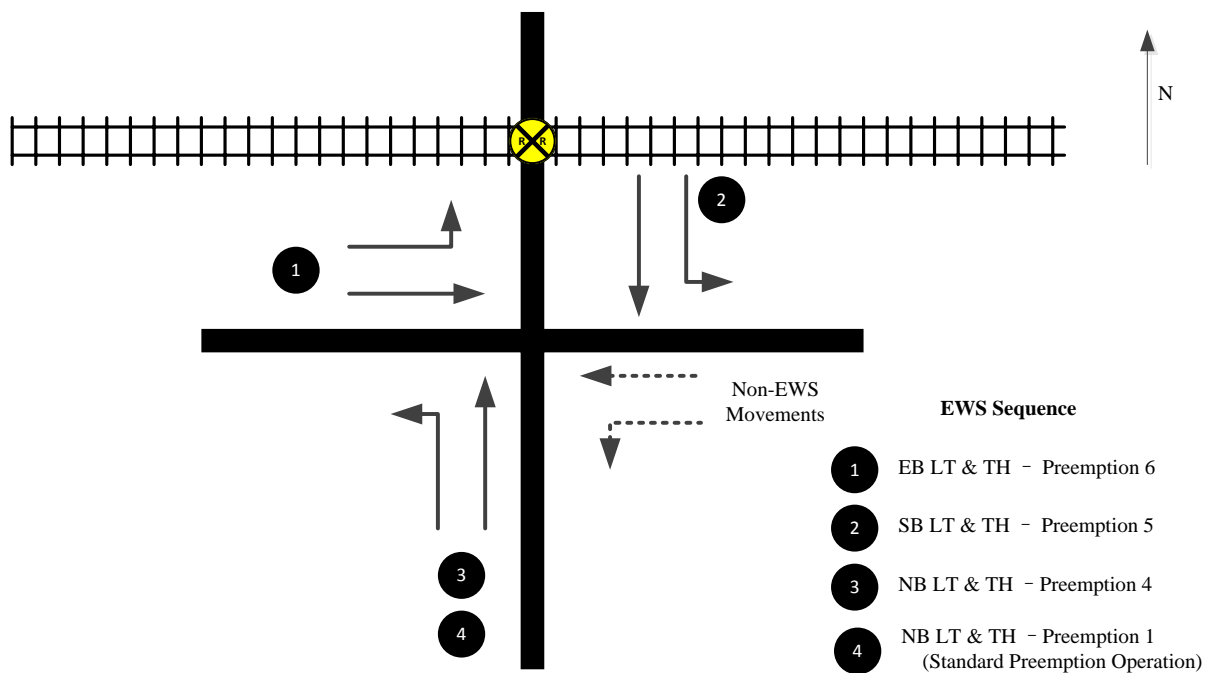

**Figure 2-2 Early Warning System Phases and Sequence**

Regardless of the status of the EWS, a train arriving at a crossing will trigger the standard preemption operation (Preemption 1) immediately. If the train arrives at the crossing earlier than the predicted time, the standard preemption aborts the current EWS phase and enters the track clearance time. If the train arrives at the crossing later than the predicted time, the last EWS phase, which is usually the phase for track clearance, will continue until the standard preemption is triggered.

However, the improvement of the Measure of Effectiveness (MOEs) with EWS was found to not be significant in the studied case. The effectiveness of the EWS is highly dependent on

---

site geometry and vehicle/train volume. The EWS is designed to work at an individual intersection next to a railroad crossing. No coordinated operations are considered for the upstream or downstream intersections along a roadway corridor. Isolated operation limits the performance of the EWS to clear through movements along the whole corridor before train's arrival.

### 2.2.2 Improved Transition Preemption Strategy

The Transition Preemption Strategy (TPS) algorithm (S. Venglar, 2000) was originally developed by the Texas Transportation Institute (TTI) to serve the purpose of avoiding the abbreviation of the necessary signal interval length. According to this approach, at the upstream of the track circuitry used for the constant warning time (CWT) system, the train is detected with an advance preemption warning time (APWT) detection system. The APWT detection system includes several upstream Doppler radar sensors, providing the train speed information and thus allowing the TPS algorithm to predict the train's ETA. The TPS algorithm begins affecting signal operations once the ETA is equal to the preset threshold until the onset of the regular railroad crossing preemption.

In the study of the TPS, it was found that approximately 30 seconds could be used by the algorithm, based on the location of the Doppler radar sensors. At every second of running the TPS, the algorithm tested if the minimum green time of the current phase, the current "Do Not Walk" (FDW) pedestrian interval, and the minimum green time of the next phase would be satisfied by the remaining time before the onset of preemption. If the minimum green times of both the current and next phase were not able to be served within the remaining time, TPS omitted all other vehicular and pedestrian phases. The TPS logic was straightforward and reduced the vehicular minimum phase abbreviations and the shortening or omission of pedestrian FDW intervals, as confirmed in the micro-simulation environment.

A later study (Cho and Rilett, 2007) reported that one disadvantage of the TPS algorithm was that it resulted in providing more green time than what should normally be provided to the phases, which became the dwell phases during preemption. Since these dwell phases are served again during train crossings, the TPS may provide excessive green time to those phases and induce higher average intersection delays. Due to the variation of train speeds, the preemption may start earlier or later than TPS predictions. If the preemption is activated earlier than TPS predictions, the minimum green time of the running non-track clearance phase according to the TPS can be violated. In such cases, the pedestrian FDW interval is more likely to be abbreviated since it is usually longer than the minimum green time of the vehicular phases. On the other hand, if the preemption starts later than the

---

prediction, the green time of the track clearance phase may be excessive and thus increase the average intersection delays.

To improve mobility and safety, an Improved Transitional Preemption Strategy (ITPS) was proposed (Cho and Rilett, 2007). The ITPS algorithm added more logic tests to the TPS algorithm to provide more green time to the conflicting phases with train crossing (i.e., non-dwell phases). The results showed that the ITPS improved average intersection delays compared to the scenarios with the TPS or without any pre-preemption strategy. To eliminate the abbreviation of the pedestrian FDW interval, ITPS simply forbade any conflicting pedestrian movements, thereby preventing the violation on the FDW intervals. The ITPS aims to optimize traffic signal operations at an individual intersection rather than the whole roadway corridor. Unlike the EWS logic, the ITPS strategy works in a fully-actuated manner—vehicle arrival detection devices at the intersection are needed to start, extend, or terminate an ITPS phase. The logic of the ITPS strategy contains a series of logical comparisons and judgments that may be beyond the capability of standard traffic controllers. Thus, additional calculation modules may be needed to implement the ITPS. The ITPS logic is shown in Figure 2-3. (Source: Cho and Rilett

Figure 2-3

### **2.3 Highway-Rail Grade Crossing Safety Action Plan**

Between 2000 and 2007, the number of highway-rail crossing crashes in Florida increased steadily to about 100 crashes per year. Although the total number of railroad crossing crashes began to drop in 2008, the percentage of fatal and injury crashes was still higher than the national level. In 2010, there were 67 highway-crossing crashes in Florida, with 12 (25.5%) fatalities and 40 (59.7%) injuries. Overall in the U.S., a total of 2,004 highway-rail crossing crashes occurred, with 261 (13.0%) fatalities and 810 (40.4%) injuries.

Table 2-1 shows the number of Florida crossing incidents for both public and private crossing by injury severity.

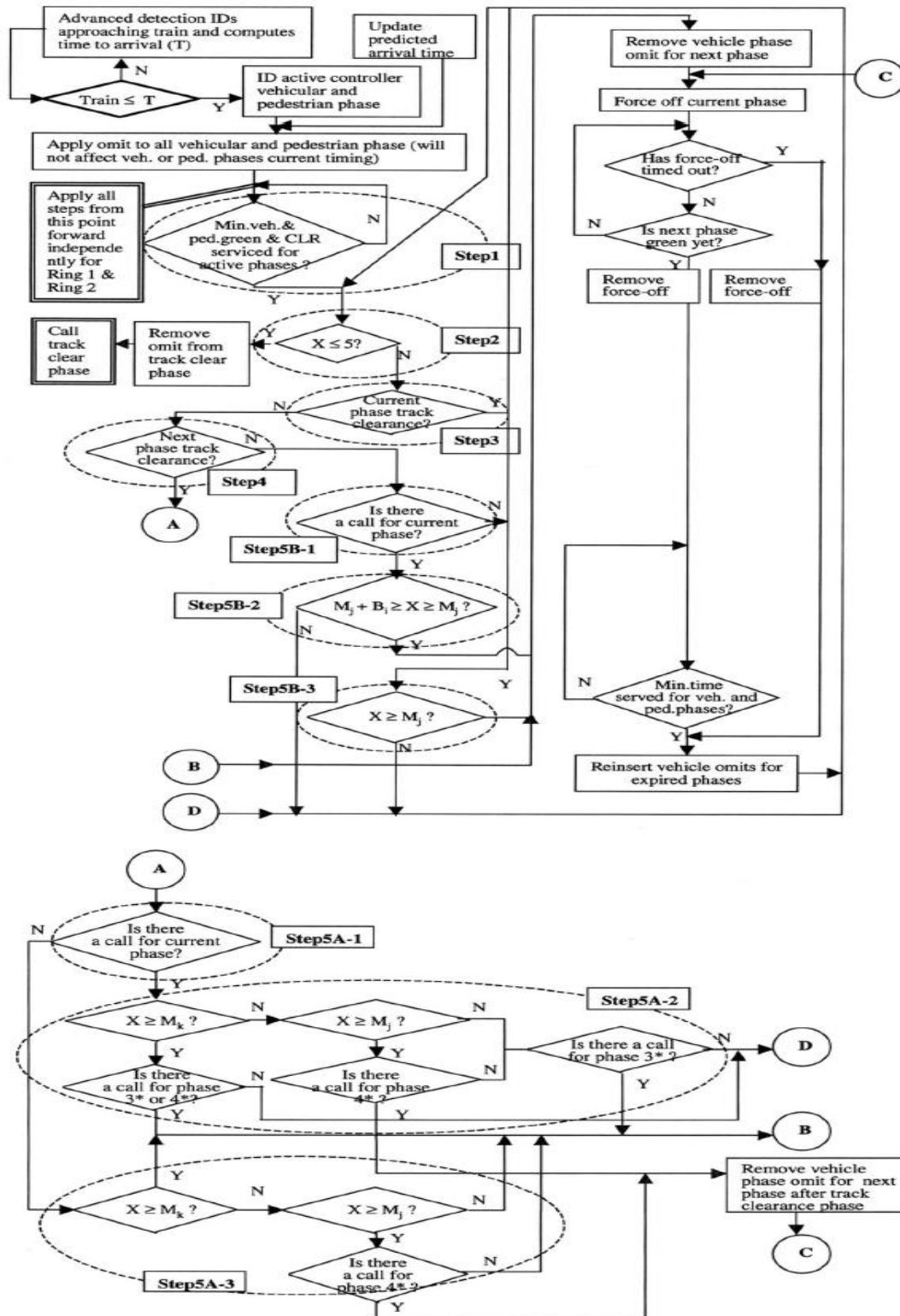

Source: Cho and Rilett

Figure 2-3 ITPS Logic Sequence



---

**Table 2-1 Florida Crossing Incidents**

	<b>2000</b>	<b>2001</b>	<b>2002</b>	<b>2003</b>	<b>2004</b>	<b>2005</b>	<b>2006</b>	<b>2007</b>	<b>2008</b>	<b>2009</b>	<b>2010</b>
Incidents	86	114	99	99	108	103	118	90	75	50	67
Fatalities	15	15	16	14	19	17	10	20	25	10	12
Injuries	67	36	32	36	35	21	35	66	30	24	40

The recently-submitted Highway-Rail Grade Crossing Safety Action Plan is a key module for FDOT and other transportation partners to follow as an effective, efficient, and systematic way to enhance railroad crossing safety (Florida Department of Transportation, 2011). The plan addresses the challengeable issues in the Florida rail system and proposes the feasible remedies under different crash types or physical conditions, as listed in Figure 2-4. Between 2006 and 2008, the majority (84%) of highway-rail crossing crashes were those occurring at urban crossings with congested arterials. Among all the strategies, research on coordinated preemption for urbanized areas is proposed as an important component to enhance urban rail crossing safety as a system wide approach rather than by individual crossings (highlighted in Figure 2-4).

Coordinated preemption will allow for communication between the traffic signals parallel to the rail corridor and adjacent to the crossing gate. Thus, using a preemption strategy would help create more time for downstream vehicles to clear the railroad crossing and reduce conflicting vehicular movements that may occur at or near the crossing gates. However, to apply this strategy on future regional and statewide corridors, research on how to accommodate different speeds, types of trains, train locations, lengths, and impacts on the traffic network is essential.

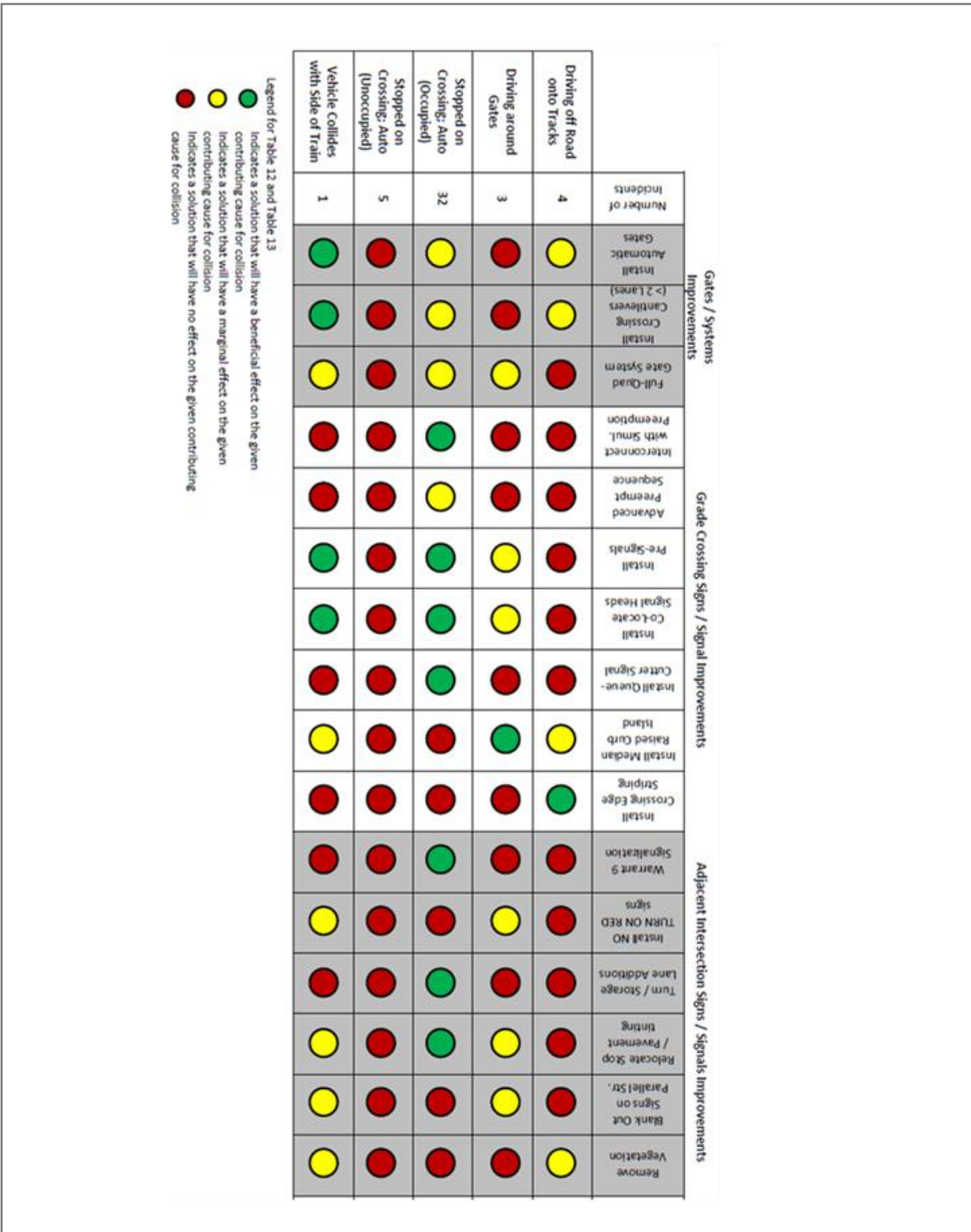

**Figure 2-4 Countermeasures of Railroad Crossing Crashes from Highway-Rail Grade Crossing Safety Action Plan**

---

## **3 GENERIC PRE-PREEMPTION PLAN**

### **3.1 Overview**

Coordinated pre-preemption for urbanized areas is an important component for enhancing urban rail crossing safety and mobility as a system-wide approach rather than by individual crossings. Coordinated pre-preemption will allow for communication between the traffic signals adjacent to the crossing gates. Thus, using a coordinated pre-preemption strategy would help create more time for downstream vehicles to clear the railroad crossing and reduce conflicting vehicular movements that may occur at or near the crossing gates.

One of major purposes of this project was to develop a coordinated pre-preemption plan and recommendations for implementation via the ATMS.now platform considering various factors and conditions. Thus, a generic coordinated pre-preemption plan based on different scenarios is expected. State and local traffic agencies should be able to use the generic coordinated pre-preemption plan developed from this project as a guide to implement coordinated pre-preemptions at signals near railroad crossings. This document describes how this generic coordinated pre-preemption plan can be applied to initiate pre-preemption strategies at target signalized intersections in selected sections of a railroad corridor.

This chapter provides the necessary information, illustrations, and procedures for developing a generic coordinated pre-preemption plan for implementation via ATMS.now and other platforms. The following major sections are included:

- Timeline for Traffic Signal Pre-Preemptions
- Data Requirements for Implementing Pre-Preemptions
- Methods to Trigger Traffic Signal Pre-Preemptions
- Procedure for Development of a Coordinated Pre-Preemption Plan
- Use of ATMS.now for Implementing a Coordinated Preemption Plan
- Identification of Criteria for Implementing Signal Pre-preemption
- Optimization of Pre-preemptions

### **3.2 Traffic Signal Pre-preemptions and Preemptions**

A coordinated pre-preemption strategy suggests “extra” green time before train’s arrival to through traffic along a roadway corridor intersecting a railroad. The pre-preemption operation for through movements should work at the intersections along the roadway corridor in a coordinated manner. If the traffic demands of other movements that are blocked by a train are close to or higher than capacity, “extra time” should be considered for

---

assignment to these movements before train's arrival. However, the number of pre-emption phases is restricted by the length of Advance Warning Time (AWT).

The coordinated pre-emption strategy can be implemented at both preempted intersections and non-preempted intersections. At non-preempted intersections, the strategy will perform pre-emption phases (coordinated phases for through movements and/or non-coordinated phases for other movements) only. At preempted intersections, the pre-emption phases start first and can be terminated by a preemption that has the highest priority.

### **3.3 Data Requirements for Implementing Pre-emption**

Before developing coordinated pre-emption plans, a traffic agency must first identify and obtain information on railroad corridors for implementing coordinated pre-preemptions and traffic signals with preemption settings within signal system network and near the corridors. For this project, the interests were the CSX and FEC railroad corridors and traffic signals with preemption settings within ATMS.now network and near the railroad corridors.

#### **3.3.1 Railroad Lines and Signal Preemption Information**

The two rail lines of interest are the South Florida Rail Corridor, which is a CSX property, and the FEC line east of I-95 and running mostly parallel to US Highway 1. The FEC line runs through the urban central business district of the communities in the region and has many preempted intersections along its route, as well as several zones with high preemption concentration.

Conversely, the CSX line has relatively few preemption intersections along its line and few zones of concentrated preemption. This is likely due to decisions made during the rebuilding of I-95 to build many overpasses and an emphasis on removing at-grade intersections on the passenger line.

The FEC line has many more preempted intersections in this zone than the CSX line. There are similar zones in Pompano Beach and Deerfield Beach that have a high density of closely-spaced preempted intersections. This is an example for the area where the preemption strategies will have the excellent chance of being successful.

The design approach defined does include any devices requiring direct contact with railroad infrastructure. The FEC line has many more preemption intersections than the CSX line. Given a sufficient grouping of nearby preemptions, trains can be monitored in the corridor. Train monitoring can include assignment of direction, estimated average speed, estimated

---

train lengths (given a long-enough monitored corridor), and an estimated location. This train information is sufficient to generate ETAs and estimated times of departure (ETDs) at downstream locations.

### 3.3.2 Railroad System-Related Information

Train approach directions, average speeds, train lengths, and locations are all the important components. The research team estimated all these metrics since the railroad system supplies only a relay closure when a train has a defined arrival time at an intersection.

### 3.3.3 Second Software

The research team considered the feasibility of using a second software system that could extract the preemption information from ATMS.now and generate ETAs and ETDs for downstream intersections. The software could also initiate pre-preemption at these downstream intersections, giving extra time for vehicles to clear the grade crossing and potentially generating traveler information messages for corridor DMS. The ATMS.now software could be configured to log preemption times and generate reports depicting delay times at the grade crossing. If the ATMS.now software was unable to provide this feedback, the external software system could.

### 3.3.4 Detectors

Radar detectors would supplement the preemption detection and would not interface with any railroad equipment or be on the railroad's right-of-way. The detectors would be solar-powered and provide non-vital advance train's arrival information.

## **3.4 Methods to Trigger Traffic Signal Pre-preemptions**

### 3.4.1 Preemption Trigger

The railroad preemption circuit provided by railway companies in a signal controller cabinet at a signalized intersection to trigger the signal preemption is currently the only way to detect a train in the rail corridor. This signal preemption can be monitored by the closed-loop software ATMS.now and can be used to trigger a pre-preemption plan at traffic signals downstream of the grade crossing where the train is detected using the preemption circuit. Therefore, if a traffic signal does not have a railroad preemption circuit, it will not be possible to provide train's arrival information to trigger pre-preemption at the target intersection(s).

Generally speaking, a signal pre-preemption can be triggered by one of the following inputs:

- 
- Upstream railroad preemption circuit
  - Upstream train detection sensors
  - Gate-down detection at upstream railroad crossings
  - Train GPS information obtained from train companies or a third party

This project focused mainly on the use of existing devices for signal preemptions, so more consideration was given to using the trigger from the preemption circuit to determine the presence of the train. Other pre-preemption triggers are briefly described.

Traffic signals located within a distance of 200 feet of highway-rail grade crossings will always have preemption settings. For the purposes of this generic plan, using only the trigger from the preemption circuit to determine the presence of the train was considered. The usual preemption circuit uses constant warning-type circuit logic to trigger the preemption to provide a constant warning time before the arrival of the train at grade crossings. The constant warning time will be approximately 20–25 seconds in the case of simultaneous preemption or a fixed interval longer in the case of advance preemption. However, the railroad preemption circuit provides only the time of onset of preemption and the time of release of preemption.

In some deployments, train detection devices (usually off the railroad right-of-way) have been used. These devices provide the presence of the train, direction the train is traveling, and train speed. These sensors are strategically located either at at-grade crossings or at strategic locations between grade crossings. Gate-down sensors are also an option to identify a specific action during the preemption sequence. However, even this technique indicates only the instant the gate is down just before the arrival of the train and the instant the train has left the grade crossing. Finally, it might be possible to obtain the train location and speed by continuously monitoring the train location using GPS information from the train companies. It is, however, very unlikely that train companies would provide this information.

### 3.4.2 Pre-preemption Using Upstream Preemption as the Trigger

In all the algorithms discussed (other than direction), speed was a critical number. Unfortunately, speed is never directly measured using the preemption system as data inputs, and there will be relatively few preemption data points to use in the calculations. Compounding that, train speeds can vary for many reasons, even when the railroad is operating normally. Train speed is so critical that a method to measure the speed more frequently is highly encouraged. The preemption solution requires at least two intersections

---

to derive any useful information, and the information does not become available until the train arrives at the second intersection.

For a system using preemption to be effective:

- There should be numerous preempted intersections in a linear corridor, with intersection spacing at around ½ mile.
- Along with the multitude of active intersections, the operations on the railroad line need to be very consistent.
- Trains need to maintain a more consistent, even speed and have very few reasons to stop or exhibit erratic moves.
- Areas near a railroad yard, crew change point, or an industrial area with spur tracks that serve businesses will be problematic.
- Choosing a corridor that contains a railroad passing siding will also prove problematic, as most trains will pass through but some will stop and wait for an opposing train in the passing siding.
- For lines hosting commuter rail, a passenger station will create routine slowing, accelerating, and waiting for commuter trains.
- A double track can also complicate the procedure, where the second preempt may initiate before the release of the first preempt.

An enhancement to the preemption-based concept could be considered. The enhancement would use right-of-way Doppler radar detectors to directly measure the train's direction and speed and also to get a more precise measure of the train's length and location. The location is updated when the train enters the radar system's detection area. Systems using this approach have been deployed and are operable in Garland and Sugar Land, Texas.

### **3.5 Procedure for Development of a Coordinated Pre-Preemption Plan**

#### **3.5.1 Applicability of Signal Pre-preemptions**

Pre-preemption strategies can be applied when ETA is much larger than constant warning time (CWT). The desired time gap between ETA and CWT depends on the strategies.

---

### 3.5.2 Calculation of ETA and ETD at Target Crossings

Simultaneous preemption and advance preemption are two types of railroad preemptions currently in practice. Simultaneous preemption is designed when the traffic signal controller unit and the railroad active warning devices receive notification of an approaching train simultaneously. Simultaneous preemption is typically used where the minimum warning time needed for the operation of the railroad active warning devices (flashing lights and gates) is sufficiently long enough to clear stationary vehicles safely out of the crossing. When the signal controller unit needs to receive the notification earlier than the activation of railroad warning devices and traffic signal preemption, an advance preemption is used.

By law, railroad companies are required to provide traffic agencies with at least 20 seconds advance warning of the train's impending arrival at the grade crossing. However, most railroads try to provide traffic agencies with approximately 25 seconds advance warning for simultaneous preemption. Additional warning time (i.e., more than the required 20 seconds) can be requested from the railroad to provide advance preemption. The usual preemption circuit uses constant warning type circuit logic to trigger the preemption to provide a CWT before the arrival of the train at the grade crossings. The CWT will be approximately between 20–25 seconds.

To effectively track a train through a rail corridor, the following four characteristics of the train need to be known:

- Train direction
- Train speed
- Train length
- Train location

If a train can successfully be tracked in the corridor, predictions can be made to estimate the position of the train in the corridor at a future time. This prediction can generate an estimated time of arrival of the train at a location downstream, the time a train will occupy a grade crossing, and the time at which the crossing will be clear of the train.

### 3.5.3 Train Direction

For example, consider the following basic rail corridor with four grade crossings equipped with preemption, as shown in Figure 3-1.



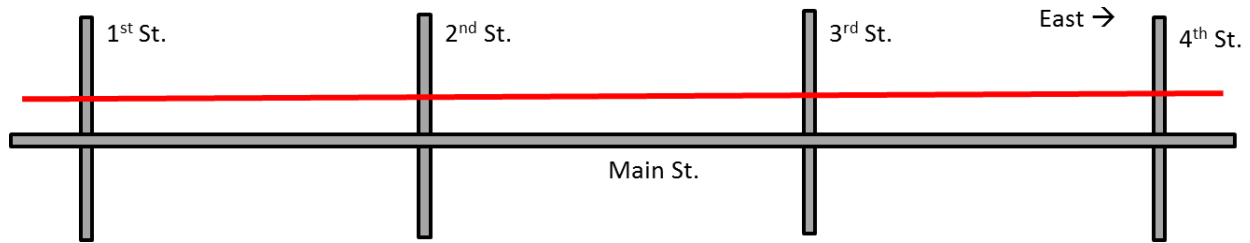

**Figure 3-1 Sample Rail and Highway Corridor**

The direction of the train can be determined by examining the time sequence of preemptions. If the corridor has been dormant (no preemptions seen for a defined extended period of time) and a preemption is seen at 1<sup>st</sup> St., the assumption can be made that an eastbound train is arriving at 1<sup>st</sup> St. Conversely, if preemption is first seen at 4<sup>th</sup> St. after a dormant period, a westbound train can be assumed to be arriving. Downstream intersections will preempt in sequence to further confirm the train's direction.

Although the logic is somewhat obvious, complications can arise due to railroad maintenance of intersections, railroad track inspectors "high railing" (inspecting the track via a pickup truck with special wheels to match rail width), and general railroad track maintenance machines. In each of these cases, the railroad equipment can prematurely activate a grade crossing and/or activate the crossing after the equipment has departed. The situation is an anomaly, and any prediction solution must take unexpected inputs into account and have a defined response when confusing data are detected.

### 3.5.4 Train Speed

The current preemption system that is accessible by the highway authority does not report train speed. Railroads will post a maximum authorized speed for every segment of the railroad, although a train may not travel at this speed. Additional rules reduce speed in areas due to a variety of issues, including current condition of the railroad's physical plant, the commodity the train is carrying, particular equipment in a train, etc. Trains should not exceed the maximum, but there are no rulings about traveling under the maximum. In regions where train movement is governed by a line-side signal system (typically called Centralized Traffic Control or CTC), the line-side signals convey movement instructions to train crews, including speed restrictions based upon signal indication.

In the absence of an external train speed measuring device, the train speed can be estimated as an average speed between grade crossings. A review of grade crossing design

---

documents will reveal the railroad's grade crossing warning system (lights and gates) start time (CWT) ahead of the train. For instance, FRA mandates a minimum of 20 seconds of intersection activation time in the traffic signal controller before the arrival of the train. It is very common for the railroad to add a buffer time to the mandated minimum, yielding a warning time closer to 25 seconds. Intersections configured in this manner are said to have simultaneous preemption. If the warning time provided is longer than the FRA minimum, then the intersection most likely has advance preemption. Advance preemption is used at at-grade crossings where there is a need for additional time to safely clear an intersection ahead of the train's arrival.

If the grade crossings in the corridor are all configured for simultaneous preemption, then preemption in the traffic signal controller should happen approximately 25 seconds prior to the train entering the intersection, regardless of the train's speed. Consider the example in Figure 3-2.

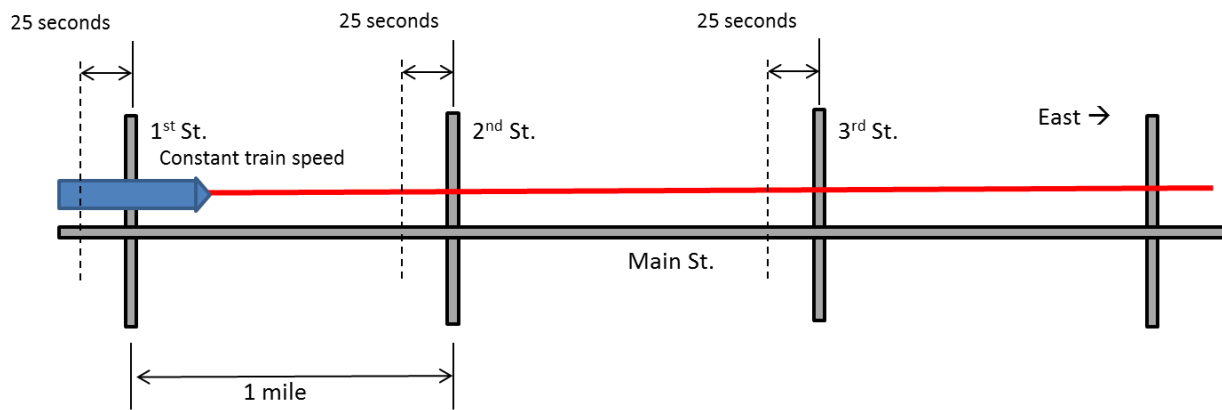

**Figure 3-2 Train Average Speed Calculation**

It is important to note that the beginning of preemption does not define where the train is physically located in the corridor; rather, it defines the train's position from the grade crossing from a time point of view. A fast-moving train will be further away from the grade crossing than a slow moving train at the beginning of preemption.

In the example illustrated in Figure 3-2, the train has preempted 1<sup>st</sup> St. and is occupying 1<sup>st</sup> St. The time of activation of the preempt at the 1<sup>st</sup> St. is known and recorded. When the train triggers the preemption at 2<sup>nd</sup> St., a second onset of preempt time will be recorded. Again, assuming a constant train speed, the train speed estimate can be determined by dividing the distance between the two intersections by the time differential between the two

---

preemption starts. In this example, the distance between intersections is 1 mile, and the time differential between the onsets of preempts is 2 minutes, resulting in an average and constant speed of 30 mph.

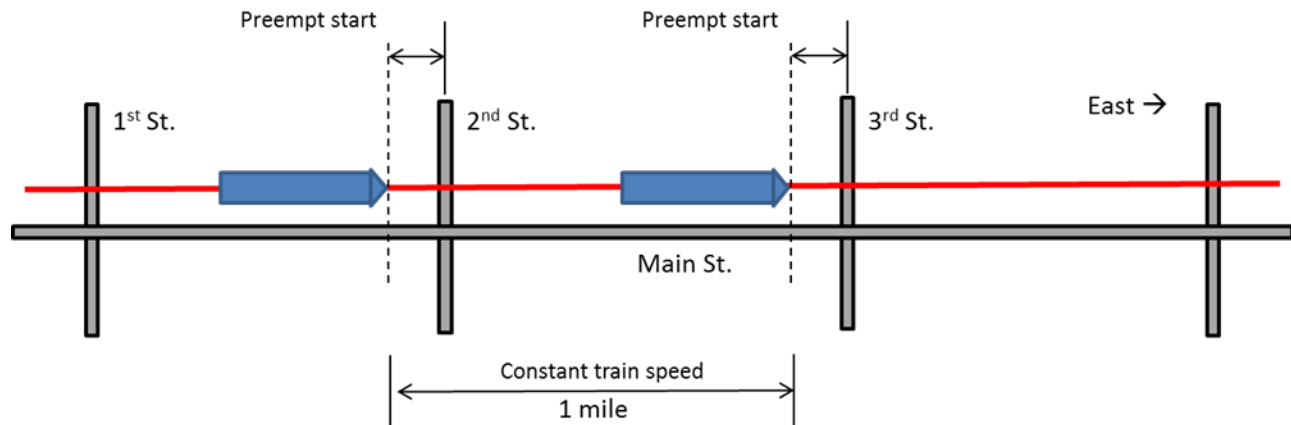

**Figure 3-3 Continuation of Average Speed Calculation**

This approach gives an average speed, but it requires the train to traverse two preempted intersections before the initial speed is recovered. The average speed of the train can then be updated as it passes each new preempted intersection. This is a rather crude method, but it can deliver a speed estimate. The assumption that the train will maintain a constant speed can be tested by reviewing a long-term record of preempt start times and determining the likelihood that a train will follow an expected speed profile. Additionally, the intersections need to be spaced at a reasonable distance to update the train's speed often. One-half-mile spacing is a good rule of thumb.

A second read on the train's speed can be achieved by calculating the speed of the rear of the train. As the train departs an intersection, the preempt releases. Capturing the preempt release time at two adjacent intersections and finding the time the end of the train took to travel from the first intersection to the second can be used in the same calculation, as previously mentioned.

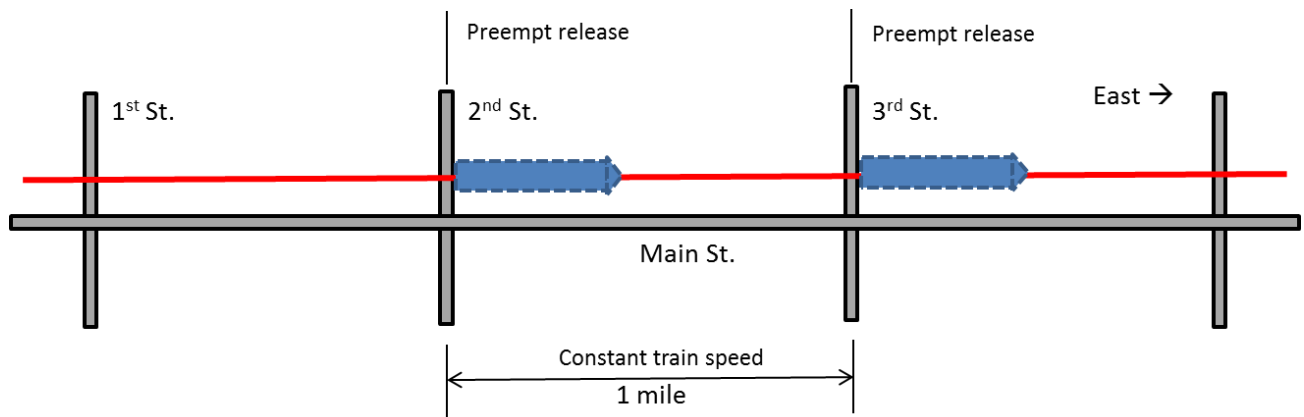

**Figure 3-4 Average Speed Calculation Using Release of Preemption at Successive Grade Crossings**

Using this approach, each intersection pair yields two speed readings per train passage. Another way to view this is that every intersection in the corridor, other than the first intersection the train preempts, will provide a pair of speed readings. The first reading comes at the start of preemption when the train is at the constant warning time start point (e.g., 25 seconds from the intersection); the second speed data come as the end of the train clears the intersection and preemption releases.

### 3.5.5 Train Length

The length of the train can be calculated by capturing the amount of preemption time the train creates. The constant warning start time will need to be subtracted from the total time, which yields an approximation of the time the train physically occupied the intersection. Employing the constant speed calculated from preemption a train length can be derived.

$$\text{Train length (in ft)} = (\text{Preemption time} - \text{CWT in sec}) \times (\text{Train speed in ft/sec}) \quad (3-1)$$

As before, this approach relies on the train maintaining a constant speed, the grade crossing CWT being stable, and the preemption release happening quickly after train departure. Since there are numerous opportunities for errors to creep into the calculation the train length should be considered a general estimate and not highly accurate.

Knowledge of the train's length coupled with the train's speed (or anticipated future speed based on past history) yields expected delay durations at downstream intersections.

$$\text{Train Delay Time} = \text{CWT} + [(\text{Train length in ft}) \div (\text{Train speed in ft/sec})] \quad (3-2)$$

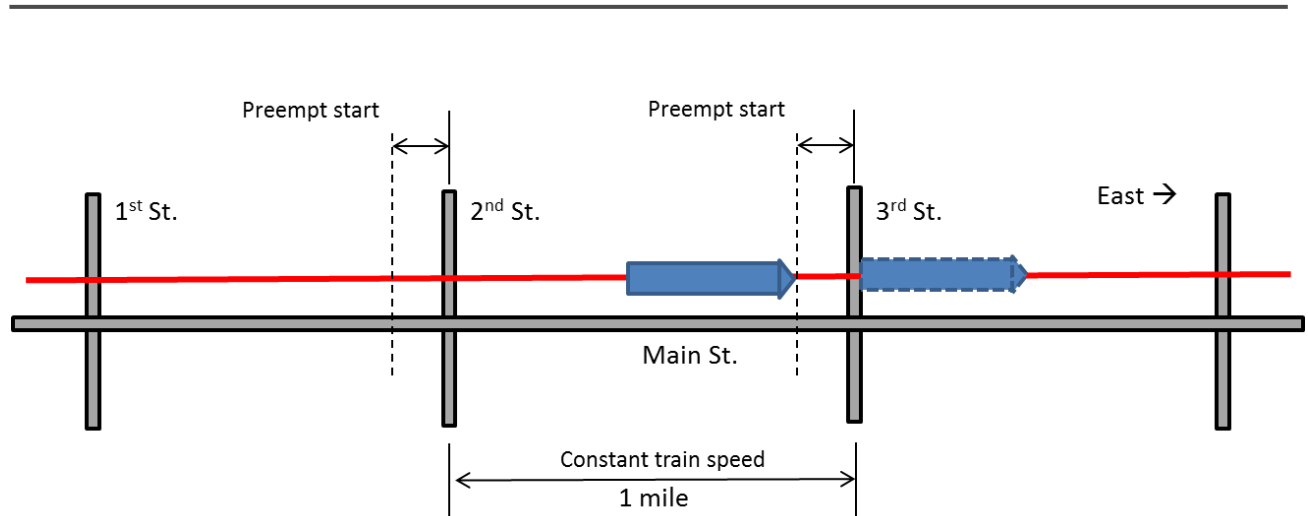

**Figure 3-5 Calculation of Train Length**

### 3.5.6 Train Location

The train's location can be plotted by using the preempt starts to locate the train at the CWT (typically around 25 seconds) before the intersection. Knowing the train's speed estimate, the train's position upstream of the intersection can be estimated.

$$\begin{aligned} \text{Train location at the onset of preemption (in ft)} &= \text{CWT (in sec)} \\ &\times \text{Train speed (in ft/sec)} \quad (3-3) \end{aligned}$$

A simple linear estimation process can be used to estimate the train's location after preemption. This solution is essentially dead reckoning until another positive location (preemption) is detected. Using a constant speed assumption, the distance downstream is calculated as.

$$\begin{aligned} \text{Distance downstream (ft)} &= [(\text{Current time} - \text{Preempt start time}) - \text{CWT}] \\ &\times \text{Train speed (in ft/sec)} \quad (3-4) \end{aligned}$$

A negative result indicates the distance the train is before the preempted intersection and will only occur if the current time is less than the preempt start time + CWT.

### 3.5.7 Estimated Time of Arrival

The algorithms discussed should all be continually updated as new data (preemptions) are logged. The fresh data will generate new train speed, length, and location estimates which can be used by other processes. For example, an ETA can be calculated by determining the distance the train is away from the target intersection and dividing that by the train's speed.

$$\begin{aligned} \text{ETA (in sec)} &= \text{Distance between train and target (in ft)} \\ &\div \text{Train speed (in ft/sec)} \quad (3-5) \end{aligned}$$

---

This ETA calculation is for the train's arrival in the intersection. Subtracting the downstream intersection's CWT yields the estimate when preemption will begin at the target intersection.

As shown in Eq. 3-5, the ETA is a function of train speed and distance. Therefore, the accuracy of ETA is also a function of distance and speed variability (or travel time). It can be shown that the standard deviation of ETA can be computed as:

$$\sigma_{ETA} = D\sigma_T \quad (3-6)$$

where  $\sigma_{ETA}$  = standard deviation of ETA (s),  $D$  = distance between train and target (ft),  $\sigma_T$  = standard deviation of train travel rate (s/ft).

The travel rate is a reciprocal of train travel speed. This equation indicates that the variability in ETA increases with the increase in distance and the variability of travel rate (i.e., 1/travel speed).

$\sigma_T$  can be computed directly from historical data such as ATMS preemption logs. It is recommended that the  $\sigma_T$  is computed for conditions where the trains are expected to share similar characteristics (e.g., weekday, weekend, peak, off-peak).

For example, consider the prediction of the ETA for a train at an intersection one mile downstream of the current location. Assume that from historical data logs we have five valid observations of travel time for this particular condition as 52, 65, 70, 45, and 58 s/mi. Then, using standard deviation formula,  $\sigma_T$  is computed to be 0.0019 s/ft. Therefore, we can compute the standard deviation of ETA as  $\sigma_{ETA} = 5280 \text{ ft} \times 0.0019 \text{ s/ft} = 10.0 \text{ s}$ .

With the  $\sigma_{ETA}$  estimated, the confidence interval of ETA can be constructed by assuming that the ETA follows a normal distribution with the mean equals to the current ETA estimate and the standard deviation equals to the estimated  $\sigma_{ETA}$ . For instance, using the same example, if the current ETA is predicted to be 60 seconds, then the 95% confidence interval of the ETA is equivalent to  $60 \pm 1.96(\sigma_{ETA}) = 60 \pm 1.96(10) = 40.4 \text{ to } 79.6 \text{ seconds}$ .

### 3.5.8 Accuracy of Field Measurements

Train direction, speed, length, and location can be estimated based on historical data as well as initial observations of preemption activity in the corridor. However, as mentioned earlier, the accuracy of these estimates is based on numerous assumptions, some of which may not be valid all the time. It is also not possible to verify the accuracy of the measurements of

---

train speed and length. Hence, predicting events that can be verified more accurately may be warranted. The only events that can be logged as they occur are the onset of preemption and the removal of preemption. Predicting the onset and removal of preemption can be observed and verified directly, and, if necessary, the prediction for future events can be fine-tuned. These events are also important because controllers employing preemption enter into a special mode at the onset of preemption and, thus, close the window to implement any pre-preemption strategies. Thus, knowledge of the estimated onset of preemption and the removal of preemption is more beneficial in a pre-preemption system using only preemption as the trigger.

### **3.6 Use of ATMS.now to Implement Pre-preemption**

#### **3.6.1 Procedure**

This section provides guidance in the use of ATMS.now for the application of pre-preemption at intersections being influenced by rail preemption activities. The objective is to monitor the onset of preemption at signalized intersections near highway-railroad grade crossings to develop and implement appropriate strategies to improve traffic operations downstream of this grade crossing. The following procedure will need to be followed to achieve this objective:

1. Use ATMS.now to monitor the onset of preemption in a signal controller cabinet having preemption.
2. Send a message to the traffic management center (TMC) about the onset of preemption using ATMS.now.
3. Continue to monitor further preemption activities along the corridor using ATMS.now. Note that the next activity may either be a preemption OFF at the intersection where preemption was ON, or a preemption ON at a downstream grade crossing, or a preemption ON for a train traveling in the opposite direction (in the case of more than one track in the corridor) at the grade crossing at the other end of the corridor.
4. Determine the estimated onset and release of preemption at downstream grade crossings using a rail monitoring algorithm.
5. Use the strategy selection logic to determine if a pre-preemption strategy should be applied at downstream traffic signals.
6. Continue to monitor the progress of the train at downstream signals to adjust the estimated onset and release of preemption at downstream grade crossings.

- 
7. Use ATMS.now to implement pre-preemption at downstream traffic signals.
  8. Return to normal operations once it is determined that the train has left the grade crossing.

ATMS.now has the necessary capabilities to facilitate the implementation of the pre-preemption. Following are the steps necessary to configure ATMS.now to implement pre-preemption. The ATMS.now server at the TMC polls the local controller to obtain status updates. The frequency of the polling will depend on the quality of communication between the local controller and the TMC. Factors influencing the quality include the type of communication, fiber, twisted pair, wireless, and number of intersections on each communication segment among others. The optimum polling is done at a frequency of one second. However, the polling frequency can be as high as once every 6–7 seconds. Monitoring the countdown of the offset counter or the max-out counter at the ATMS.now server for a local intersection is a quick way to obtain the polling frequency. Figure 3-6 is a flow chart of the use of ATMS.now to implement pre-preemption strategies using only preemption as the trigger.

**Step 1:** The ATMS.now server at the TMC polls the local controller to obtain status updates. The frequency of the polling will depend on the quality of communication between the local controller and the TMC. Factors influencing the quality include the type of communication, fiber, twisted pair, wireless, and number of intersections on each communication segment, among others. The optimum polling is done at a frequency of one second. However, the polling frequency can be as high as once every 6–7 seconds. Monitoring the countdown of the offset counter or the max-out counter at the ATMS.now server for a local intersection is a quick way to obtain the polling frequency. Figure 3-7 illustrates the Intersection Status Screen where the max-out timer can be monitored to determine the frequency of polling the controller. The counter is displayed from the Home menu and Real-Time Sub-menu and by selecting Scanning, as illustrated in Figure 3-8.

**Step 2:** Configure a controller alarm to monitor Preempt 1. This alarm will monitor the onset and release of Preempt 1, which is usually reserved for rail preemption. ATMS.now currently uses Alarm #49 (Preempt 1 Input) to monitor Railroad Preempt 1 (*ATMS.now Manual*, Section 6.2.2, p. 6-148). This is done under the Definitions menu by selecting the Alarm Notifications sub-menu and creating an alarm by selecting the particular alarm to be enabled for notification. As illustrated, Alarm #49 is configured to monitor Preempt 1.



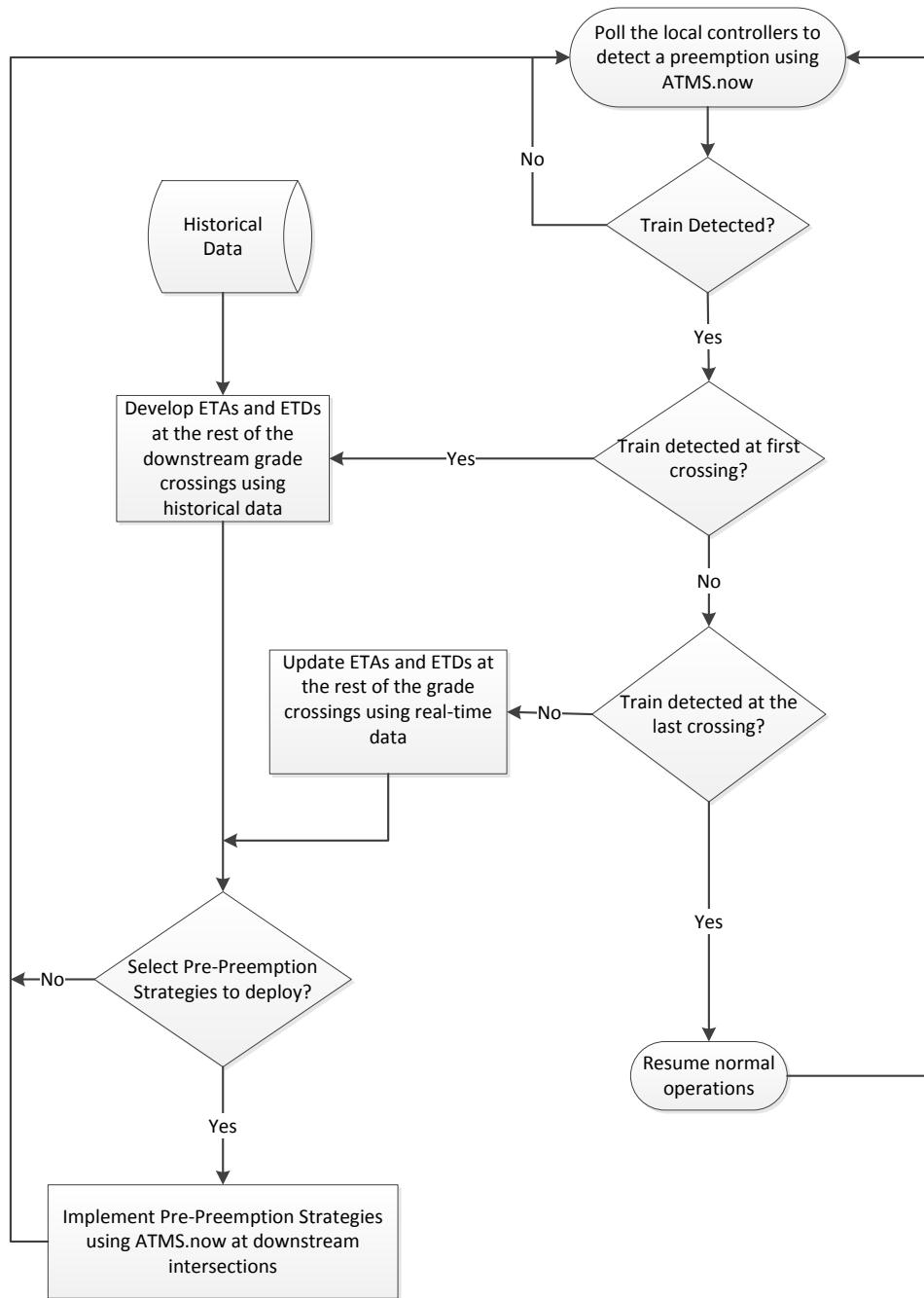

**Figure 3-6 Flow Chart for Use of ATMS.now to Implement Pre-Preemption Strategies**

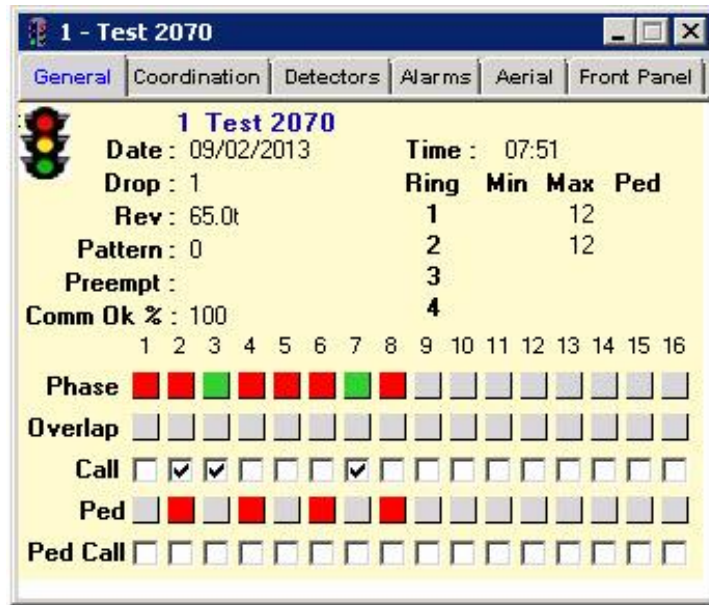

Figure 3-7 View of Max-out Counter

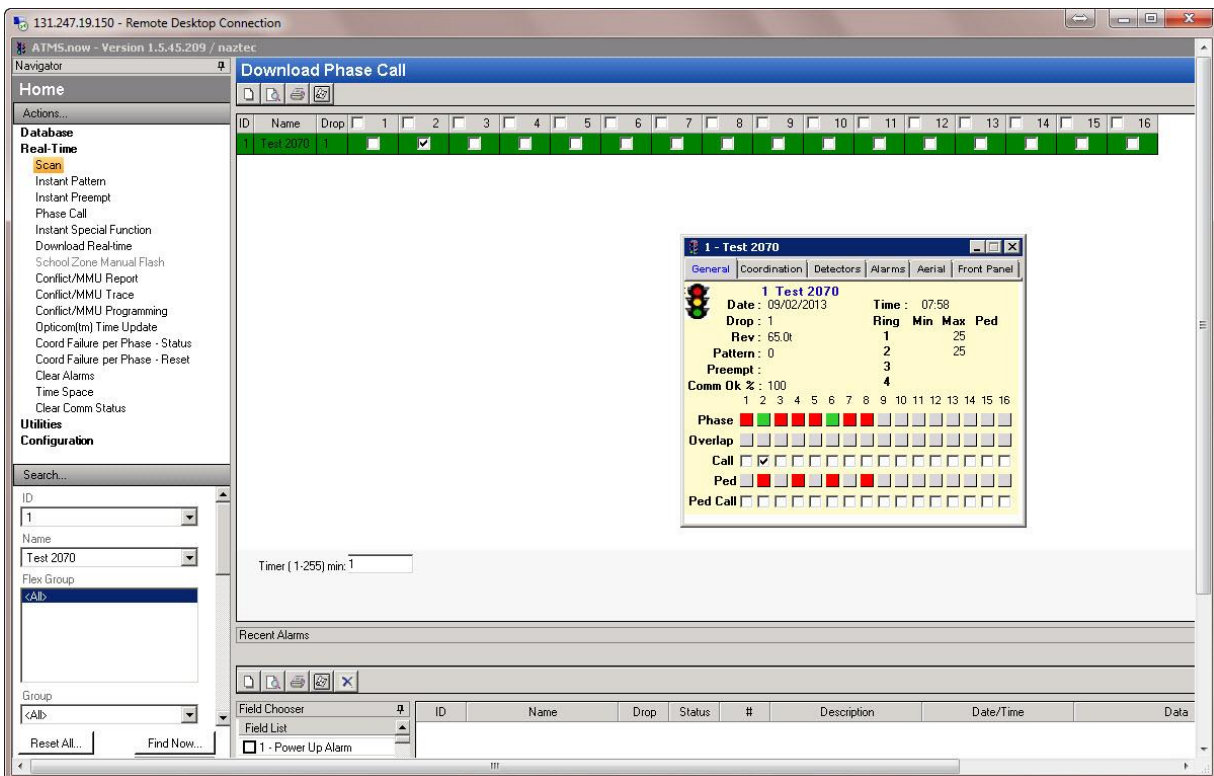
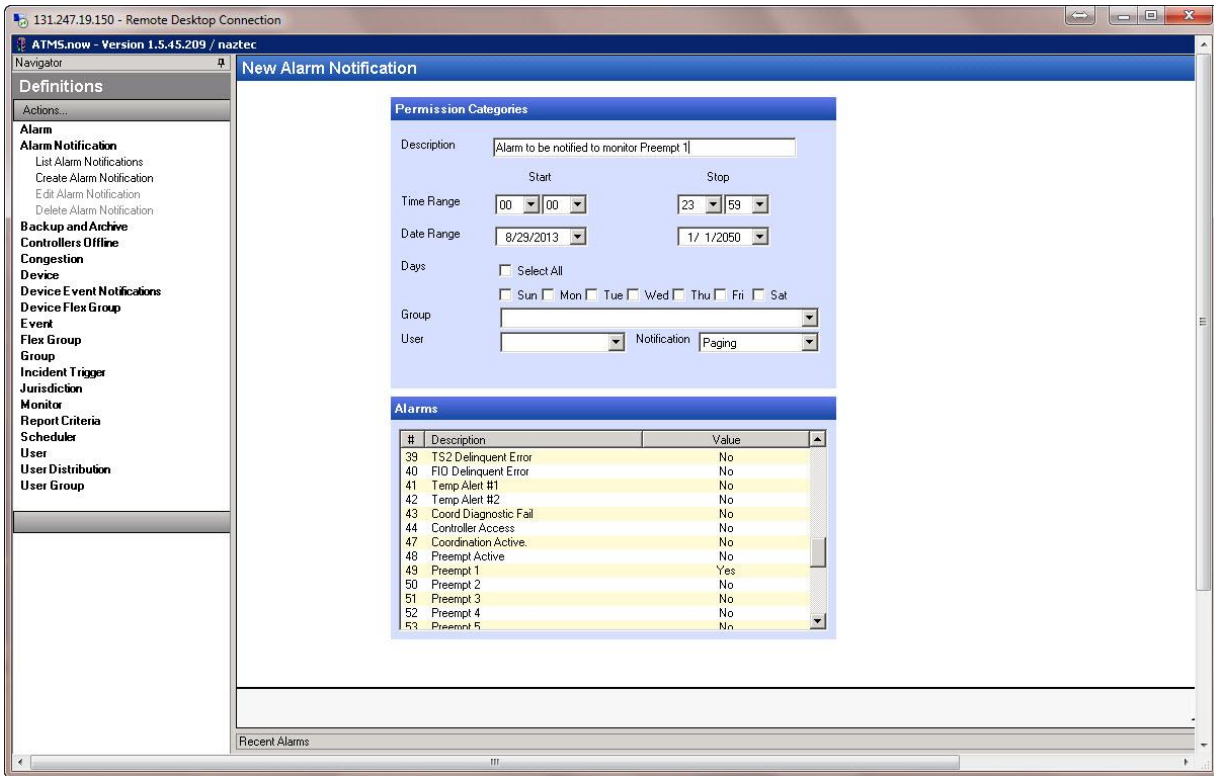

Figure 3-8 Process to Select Viewing Controller Status

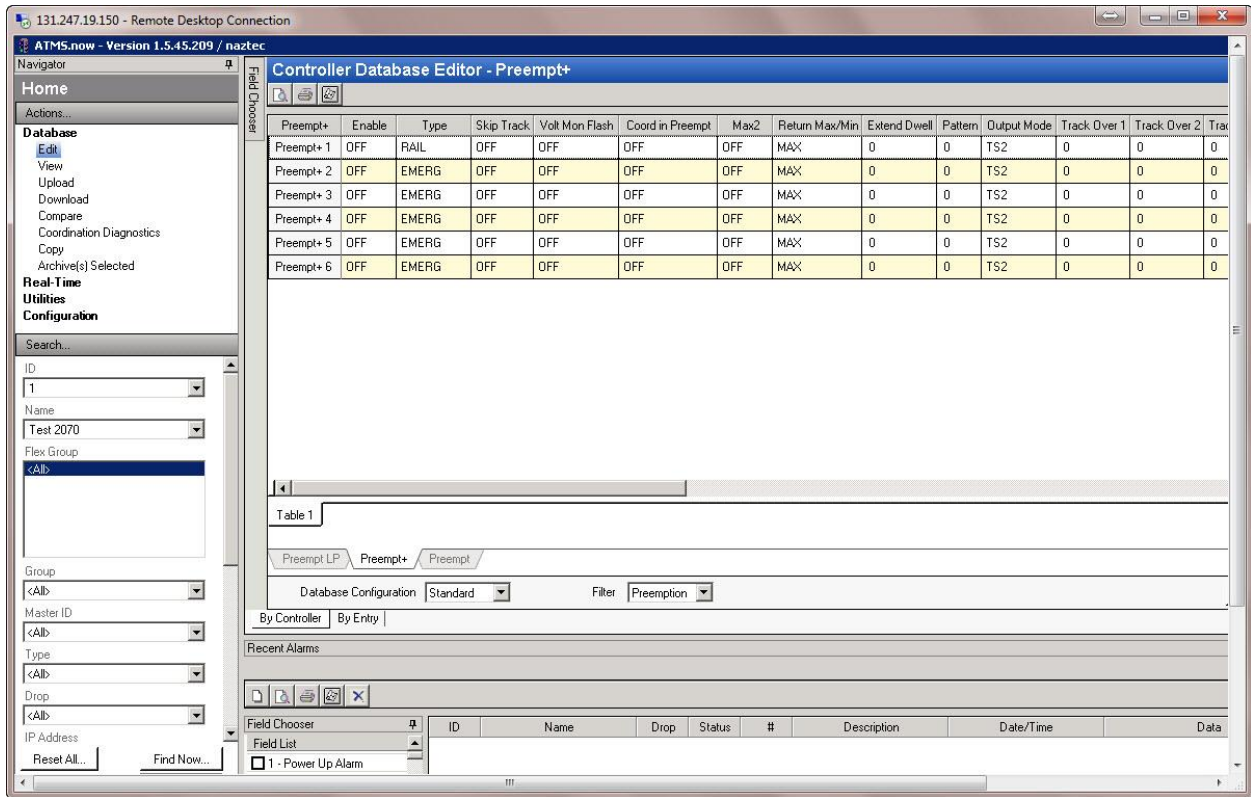

**Figure 3-9 Creation of Alarm to Monitor Preempt 1 in ATMS.now**

**Step 3:** Once a change in the status of the controller alarm is detected, the local controller is polled to get the status of the controller alarm to determine if preemption has occurred at the local controller. This polling will be updated in the SQL database in the ATMS.now server at the TMC. Poll the SQL database in the ATMS.now to monitor any change in the status of the controller alarm.

**Step 4:** Use controller alarm #49 to estimate the ETA and ETD of the train at the downstream grade crossings using a rail monitoring algorithm (an external process).

**Step 5:** Create a list of Incident triggers in ATMS.now for various strategies that are feasible to be deployed at downstream intersections (*ATMS.now Manual*, Section 6-15, p. 6-207). Select the appropriate incident trigger and implement the trigger. Usually, the trigger is a preempt to initiate a certain desired action. Figure 3-10 illustrates the designation of preempts in a signal controller for various objectives and shows that Preempt 1 is designated for Rail and Preempt 3 is designated for Emergency Service.



**Figure 3-10 Designation of Preempts for Different Objectives**

**Step 6:** A trigger is created in ATMS.now under the Definitions menu by selecting Create Incident Trigger and configuring a particular trigger, as illustrated in Figure 3-11. In this case, the trigger is to call Preempt 3, which can be configured to function as a Pre-Preemption strategy.

This trigger is applied at different intersections by applying different values of delays to achieve a cascading effect of the desired outcome (i.e., a pre-preemption strategy is implemented at the intersection nearest the intersection under preemption first and then at the subsequent intersections). This delay values are incorporated when configuring the preemption as a pre-preemption strategy.

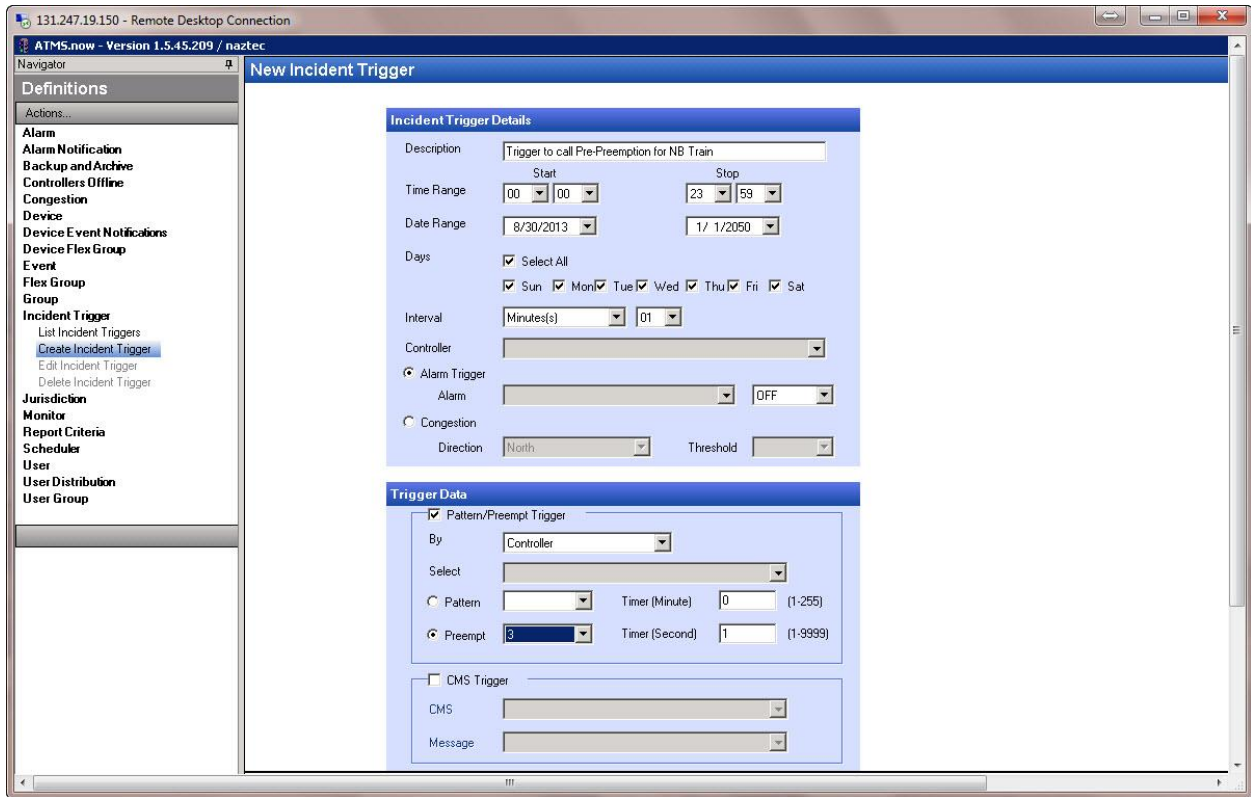

**Figure 3-11 Creation of a Pre-Preemption Trigger**

**Step 7:** Programming preempts are illustrated in Figure 3-12 and Figure 3-13. These two screens show how to program a preempt when a pre-preemption strategy calls for extended service for Phase 8. However, this strategy needs to be implemented about 30 seconds after a preempt is detected in adjacent intersection. Once a preempt is detected in the adjacent intersection, a pre-preemption strategy (Preempt 3) is applied at this intersection. The controller responds to Preempt 3 after 30 seconds and dwells in Phase 8 until Preempt 1, which is designated for "rail is active." Such a pre-preemption strategy is used when a phase such as Phase 8 is severely affected due to rail preemption.

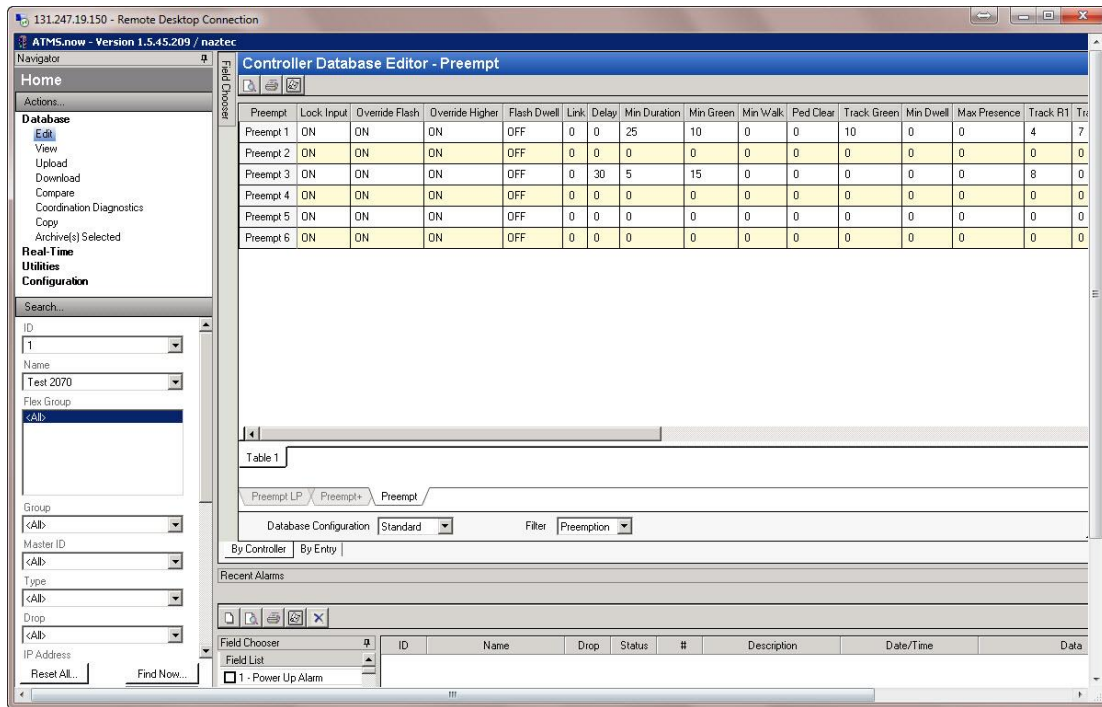

Figure 3-12 Programming Preempts (Part 1)

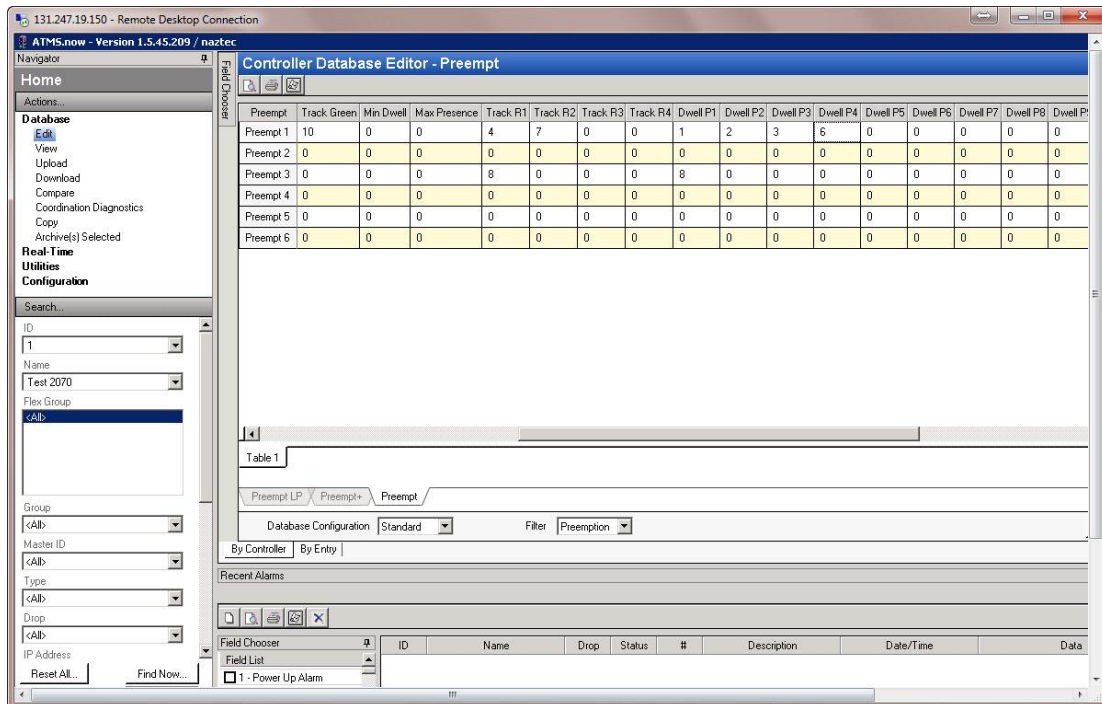

Figure 3-13 Programming Preempts (Part 2)

---

### 3.6.2 Limitations

The use of the pre-preemption triggers has the following impacts on the application of pre-preemption strategies:

- A pre-preemption strategy can be applied only after a train is detected in the preempt circuit at the first grade crossings. Thus, no strategies can be applied at the grade crossing where the train is first detected.
- Thus, for a pre-preemption trigger and a prediction using only historical data, one upstream preemption is required. However, if accuracy in prediction is required, at least two upstream preemptions are required to get a more accurate train speed.
- If the capability to log the preemption activities is not available, historical data are no longer available for the purpose of implementing pre-preemption. In such cases, train characteristics observed for each train will need to be applied to estimate the arrival and departure of that particular train. Thus, a train preemption needs to be observed at two grade consecutive crossings using preemption to determine the speed and the length of the train to estimate the ETAs and ETDs at downstream grade crossings. If, however, a more capable pre-preemption system is desired, radar detectors and a suitable communication system can be installed off the railroad right-of-way. The communication system can transmit the train data to the TMC to calculate the ETAs and ETDs of the train at each downstream grade crossing.
- Distance between the upstream grade crossing and the target crossing where preemption will be implemented is critical. The distance should be large enough so that a pre-preemption strategy can be effectively implemented. Thus, traffic engineers should have a good idea of how much time is required to effectively implement a strategy. However, if the distance of the upstream grade crossing is too large, errors can be made in the estimated time of arrival of the train at the target intersection. Based on average train speeds and the typical pre-preemption strategies, a distance of 0.5 miles between the upstream grade crossing and the target grade crossing is recommended. However, if the train speeds and lengths are fairly uniform, this distance may be as high as 1–2 miles.
- Pre-preemption strategies can be applied at downstream intersections having rail preemption only when the time gap between ETA and the current time is larger than the designated CWT for that grade crossing. Thus, if two grade crossings are very

---

close to each other and preemption usually sets in simultaneously, a pre-preemption strategy may not be possible at the downstream grade crossing.

- However, at intersections that do not employ preemption, pre-preemption strategies can be implemented before the arrival of the train can affect the intersection operations.
- The time between the detection of the train at the first grade crossings (current time) and the ETA of the train (or impacts of the train) at downstream signals influences the selection of preemption strategies. If the time available is a few seconds, then tactical strategies such as phase omit, phase hold, or low priority preempt can be deployed. Strategies such as implementation of a new signal timing plan potentially can be implemented at an intersection near grade crossings when more than a few minutes are available between the detection of a train and the ETA of the train at the grade crossing near the intersection.
- The duration of the preemption (preemption time)—i.e., time between start of preempt and the end of preempt—has an impact on the type of strategies to be implemented. If the preemption time is short (less than a minute), the impact on traffic operations at intersections affected by rail preemption is minimal. Thus, the necessity to implement pre-preemption is also limited. However, if the preemption time is long (multiple minutes), appropriate pre-preemption strategies may be applied.
- The uniformity of the preemption duration also has an impact on the strategy selection. Commuter rail systems are generally more predictable than freight rail systems and thus make it relatively easier to predict the duration at downstream intersections.
- The strategy should not be applied when trains are arriving from both directions concurrently on a double-tracked rail. The preemption events, in this case, can be triggered by a train from either direction and, therefore, it is difficult to accurately predict the ETA and ETD at the intersections.



---

## **3.7 Identification of Criteria for Implementing Signal Pre-preemption**

The need for a pre-preemption is decided based on traffic engineers' judgment and different combinations of train speeds, train lengths, traffic conditions, and the types of strategies to be considered for pre-preemption.

### **3.7.1 Connection to ATMS.now**

FDOT intends to use Naztec's ATMS.now software in its complete capability. The project is designed to use ATMS.now to obtain the information regarding the presence of a train in the corridor as well as implementation of pre-preemption strategies. Hence, an essential requirement is that the intersections that are being considered for pre-preemption must be connected to the ATMS.now system.

### **3.7.2 Gate-Down Duration**

The duration of preemption directly impacts traffic operations in the vicinity of grade crossings. Fast-moving commuter trains with only a few coaches occupy the grade crossings for a very short time. Such events may not warrant the implementation of pre-preemption. However, slow-moving freight trains may occupy the grade crossings for multiple minutes. Such trains cause greater disruption when an arterial intersects the railroad tracks, and there are multiple traffic signals along the arterial that either have rail preemption or are affected by train movements. Such rail movements in a densely-developed area, such as downtown Fort Lauderdale, can cause significant hardship to motorists.

Based on simulation results, if the duration is longer than 100 seconds, the coordinated pre-preemption strategy is suggested.

### **3.7.3 Traffic Characteristics**

As mentioned earlier, the duration of preemption has a direct impact on traffic operations in the vicinity of grade crossings. Larger preemption times negatively affect traffic operations more than short preemption times. This effect is particularly noticeable more during peak periods than off-peak periods. Thus, engineering judgment must be applied whether to implement any pre-preemption strategies during off-peak periods, especially late at night. Pre-preemption may result in more inefficient operations under low volume or off-peak conditions. Similarly, preemption activity near locations experiencing special events can cause significant disruptions when these events are in progress. However, these disruptions may not be particularly severe when special events are not in progress. Hence, pre-

---

preemption strategies may be combined with special event planning to improve traffic operations by minimizing the negative effects of rail preemption.

Based on simulation results, if through traffic volume along a roadway corridor is larger than 500 vehicles per lane per hour, the coordinated pre-preemption strategy is suggested.

#### 3.7.4 Expected Train Characteristics

The type of train or characteristics of train behavior have a significant impact on the ability to accurately predict the ETA and ETD of trains at grade crossings and, thus, the success of any pre-preemption activities. Train behavior depends on the characteristics of the corridor. A corridor with stations can have a significant variability in train speeds in the vicinity of stations. Similarly, the presence of rail yards can affect trains speeds—the more consistent the train speeds, the greater the accuracy in the prediction of the ETA and ETD of trains at-grade crossings.

#### 3.7.5 Presence of Preemption Settings at Intersections

Intersections that use preemption to clear vehicles off the track before the arrival of a train always use the highest priority for rail preemption. Rail preemption preempts all existing operations of the traffic signal controller, including any pre-preemption strategies. When simultaneous preemption is being used, rail preemption starts anywhere between 20–25 seconds before the arrival of the train. When advance preemption is used, rail preemption can start 30–45 seconds before the arrival of the train. Thus, the presence of rail preemption at an intersection can reduce the time available for some preemption strategies. On the other hand, intersections that are in the vicinity of grade crossings but that do not use rail preemption do not have the time constraint to implement and operate the pre-preemption strategy. This constraint has an impact on the type of pre-preemption strategy to be employed.

#### 3.7.6 Distance of Intersection from Railroad Crossing

The characteristics of a highway-rail grade crossing have an impact on the selection of pre-preemption strategies. This is the case not only when the railroad tracks are very close to the intersection and use rail preemption, but also at intersections where the tracks are much further away and rail preemption is not warranted and not used. In such cases, queuing studies are necessary to evaluate if queues will back up not only onto the railroad tracks, which is very dangerous, but also into the intersection when the gates are down for

---

a long period of time. Such intersections require a special type of pre-preemption strategies to maintain railroad safety as well as improve intersection efficiency.

### 3.7.7 Intersection Mode of Operation: Coordinated, Actuated, or Pre-Timed

The mode of operation of the intersection has an effect on the selection as well as the effectiveness of pre-preemption strategies. A pre-preemption strategy will most likely disrupt the coordinated intersections. Once the pre-preemption strategy is removed, the traffic signal controller may take anywhere from 2–6 minutes to regain coordination. Selection of pre-preemption strategies must be made judiciously so as to minimize the negative effects of losing coordination during the application of the pre-preemption strategy.

## 3.8 Optimization of Pre-preemptions

Based on the simulation results, coordinated pre-preemptions are site-specific strategies. The impacts of the strategies are significant at some sites for some criteria (MOEs). But at other sites, the impacts may be not significant and may even be negative. The effectiveness of pre-preemptions is decided by the parameters (phase type, phase sequence, phase time, and offset time) optimized for special scenarios. Inappropriate parameters may result in ineffective impacts on traffic operations in the roadway network.

Current traffic signal optimization packages (Transyt 7F or Synchro) do not consider special requirements for pre-preemptions. A simulation-based optimization procedure is suggested to optimize the parameters of pre-preemptions for various traffic scenarios before implementing the pre-preemptions.

---

## **4 DEVELOPING THE METHOD FOR USING ATMS.NOW TO REPORT AND ARCHIVE TRAIN DELAY**

The research team identified the data required to determine train delay performance measures. These data included train data, traffic data, geometric data, and signal timing data and had to be obtained from various sources. The objective was to determine the performance measures being generated by ATMS.now software. The following list provides additional details of the data required:

- Corridor Characteristics
  - Length of the corridor
  - Number of grade crossings
  - Spacing between grade crossings
  - Locations of train stations
  - Information regarding train movements including train characteristics
- Intersection Control
  - Signal timing information
  - Pedestrian phases
  - Preemption phase sequence
  - Detector information
  - Mode of operation
- Traffic Characteristics
  - Traffic patterns along the corridor (e.g., volumes, peak-period directions, off-peak patterns)
  - Traffic composition (e.g. passenger cars, trucks, school buses)

A review of Chapters 6 and 7 of the *ATMS.now Manual* provided the following information.

### **4.1 Congestion Levels**

ATMS.now determines and displays congestion levels on a GIS map. An external detector mapping mechanism uses Wavetronix Smart Sensor HD to determine the Congestion Levels in a segment. The Wavetronix integration provides GIS map interface for real-time “hover” status providing volume, occupancy, and speed information to each corresponding icon on the GIS map.

The segment editor is the tool that defines how ATMS.now collects and displays the incoming Volume, Occupancy, and Speed data and displays them on a GIS map. Congestion

is displayed by drawing segment lines and associating them with approaches. Congestion at an intersection is determined by the configuration on the Congestion tab. The user can define and edit an intersection's congestion level definitions for the purposes of proper display on the Congestion layer of the GIS map, as illustrated in Figure 4-1. This section determines the congestion levels based on the volume and occupancy as measured by the assigned detectors. A maximum of six detectors can be assigned to each approach. Based on these criteria, ATMS.now can assign congestion levels for an intersection into three levels—Low (displayed in green), Medium (displayed in yellow), and High (displayed in red). Congestion levels are also displayed for each approach as Low, Medium, and High.

The image displays a grid of eight configuration panels, one for each approach: North Bound, North-East Bound, South Bound, North-West Bound, East Bound, South-East Bound, West Bound, and South-West Bound. Each panel is structured as follows:

- Approach Name:** Located at the top of each panel.
- Measurement Type:** Two radio buttons are present: 'Occupancy' (unselected) and 'Volume' (selected).
- Level Thresholds:** Two rows of input fields. The first row is labeled 'Medium' and the second is labeled 'High'. Each row contains two input boxes, one for 'Occupancy' and one for 'Volume', both currently showing the value '0'.
- Detectors:** A section titled 'Congestion Level Detectors' containing six dropdown menus, each with a '0' and a downward arrow, indicating that no detectors are currently assigned.

**Figure 4-1 Congestion Level Definitions in ATMS.now**

---

## **4.2 Incident Triggers**

ATMS.now includes incident triggers that can cause pre-programmed reactions in other controllers. For example, the onset of a certain event in a certain controller can trigger a well-defined sequence of events in other signal controllers specified by the user. Events such as power-up alarm, certain patterns, congestion levels, and preemption can trigger other controllers to behave a in a certain manner.

## **4.3 Summary of Report Types**

ATMS.now includes numerous reports available to the user. Some of the available reports that are applicable for this project include:

- Vehicle Travel Time Report
- Preemption
- Real-Time Congestion Data
- LOS Average by Day
- LOS Hourly Day Graph
- LOS Multi day Graph
- Turning Movement Volume/Occupancy Report
- Volume In/Out per Day

The report most applicable for determining the impact of preemption on traffic conditions is obtained from the LOS Hourly Day Graph, as illustrated in Figure 4-2.

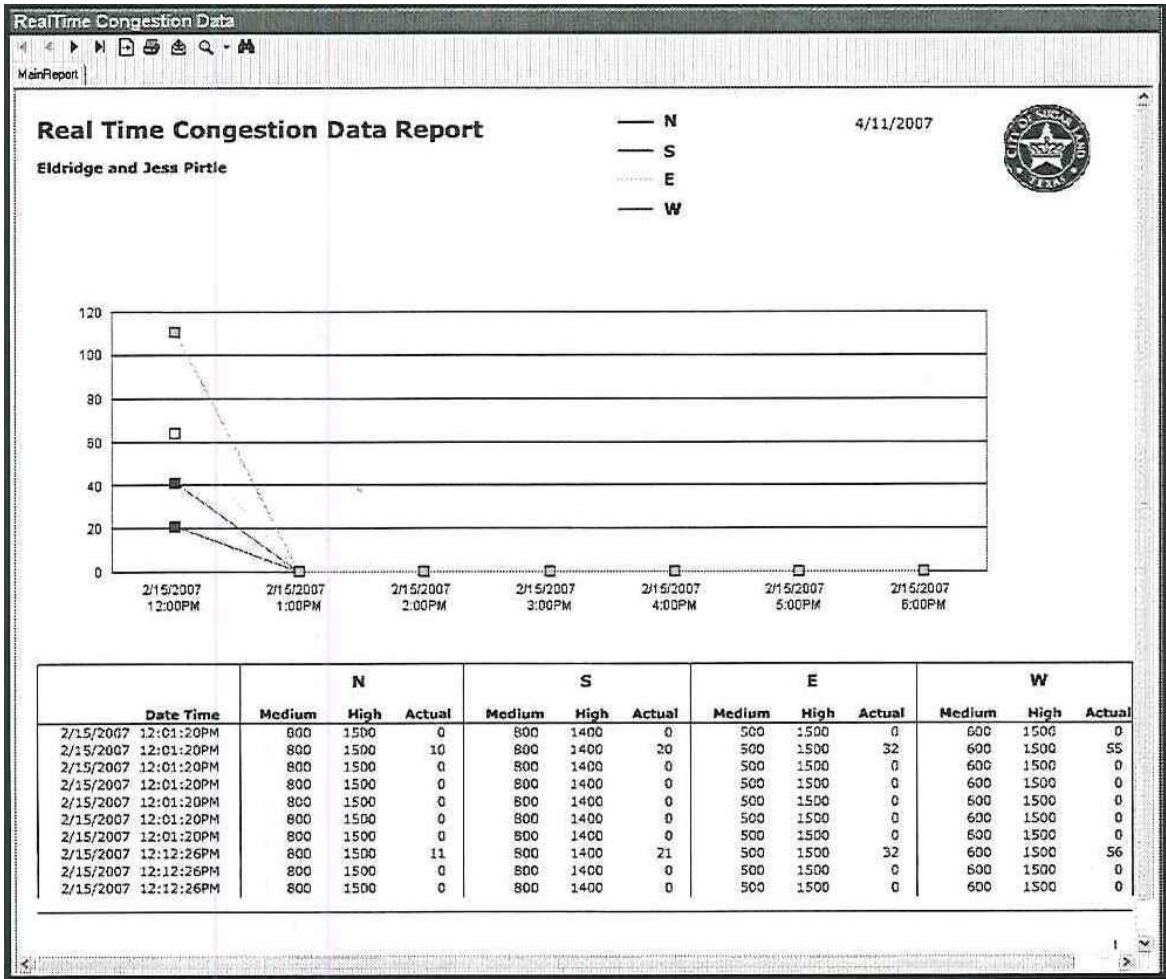

Figure 4-2 Real-Time Congestion Data Report

---

## **5 DEVELOPMENT OF COORDINATED PRE-PREEMPTION STRATEGY**

This chapter describes the algorithm of the coordinated pre-preemption strategy developed in this study. The first section provides an overview on the pre-preemption system, and the second section describes the logic of the coordinated pre-preemption strategy. A brief comparison of the coordinated pre-preemption strategy and other pre-preemption strategies is given in the last section.

### **5.1 Overview**

The major purpose of this study was to develop a pre-preemption system that would conceptually have following features (Roberts and Brown-Esplain, 2005):

- Capability to detect a train approaching a railroad at-grade crossing
- Capability to confidently predict the time that train arrive at the crossing
- Ability to mitigate congestion caused by a train passing the crossing along the corridor intersecting railroads
- Ability to minimize the probability of vehicle-train and vehicle-vehicle collisions near the crossing
- Compatibility with existing traffic controllers and traffic management system
- No need for any changes to railroad control systems
- Easy and inexpensive to design, build, implement, and maintain

Functionally, a typical pre-preemption system has three components: detection, prediction, and control strategy. The system architecture is shown in Figure 5-1.



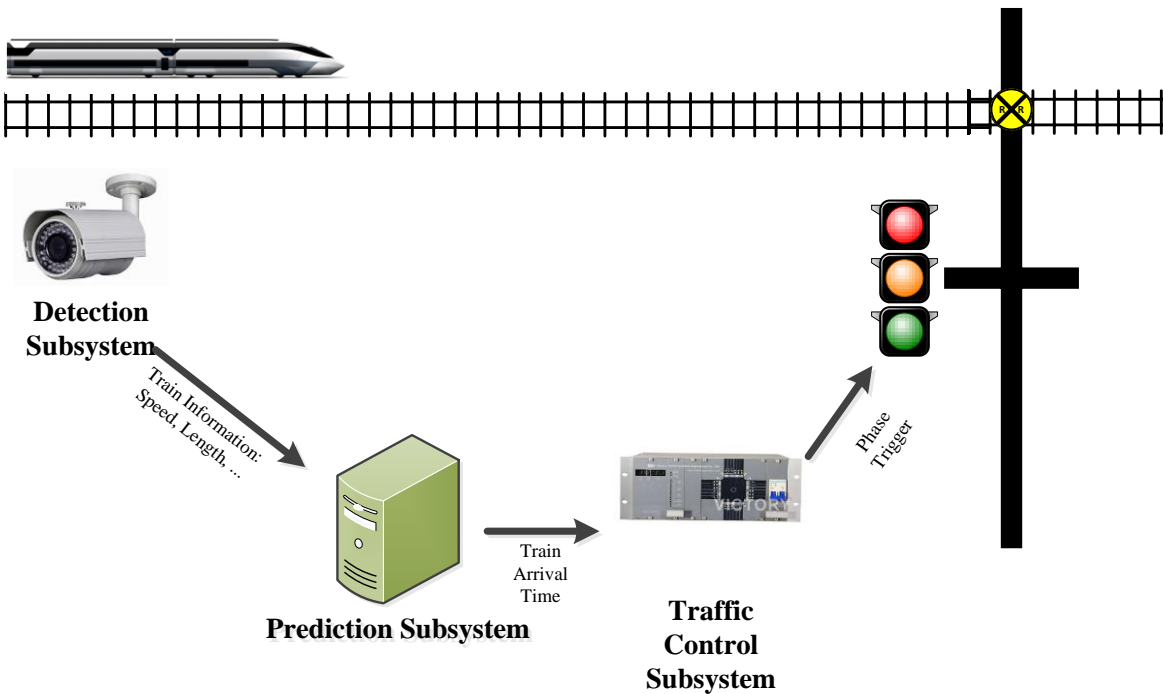

**Figure 5-1 Pre-preemption System Architecture**

## 5.2 Detection Subsystem

The detection subsystem detects an approaching train at a much longer distance from a railroad at-grade crossing than the classic train detection system. The information related to train detection, including train speed, train length, and train location, is used by the prediction subsystem for estimating the time of train's arrival at the crossing. Many technologies have been developed to detect an approaching train. The available technologies are summarized in Table 5-1. Each technology has its advantages and disadvantages. The selection of technology should consider the following factors:

- Requirement of advance warning time
- Reliability and accuracy of technologies
- Implementation cost
- Policy restrictions from rail companies and highway agencies

**Table 5-1 Train Detection Technologies**

<b>Technology</b>	<b>Location</b>	<b>Operated by</b>	<b>Advantages</b>	<b>Disadvantages</b>
Track Circuit	Rail Tracks	Rail Company	<ul style="list-style-type: none"> <li>• Mature technology</li> <li>• Reliable</li> </ul>	<ul style="list-style-type: none"> <li>• Permission from rail companies required</li> </ul>
GPS	In Train	Rail Company	<ul style="list-style-type: none"> <li>• Track train in a continuous manner</li> <li>• Robust to speed variance</li> <li>• High accuracy</li> </ul>	<ul style="list-style-type: none"> <li>• Permission from rail companies required</li> </ul>
Radar Detector	Roadside	Highway Agency	<ul style="list-style-type: none"> <li>• Independent of rail system</li> <li>• High accuracy</li> <li>• Collect train length and speed</li> </ul>	<ul style="list-style-type: none"> <li>• Cannot provide continuous train track information</li> <li>• Accuracy of predicting train's arrival time impacted by train speed variance and detector location/number</li> <li>• High installation and service cost</li> </ul>
Video Detector	Roadside	Highway Agency	<ul style="list-style-type: none"> <li>• Independent of rail system</li> <li>• Collect train length and speed</li> </ul>	<ul style="list-style-type: none"> <li>• Cannot provide continuous train track information</li> <li>• Accuracy of predicting train's arrival time impacted by train speed variance and detector location/number</li> <li>• High installation and service cost</li> <li>• Impacted by environment conditions</li> </ul>
Upstream Preemption Trigger	Traffic Management System	Highway Agency	<ul style="list-style-type: none"> <li>• No additional permission from rail company needed</li> <li>• Low installation and service cost</li> </ul>	<ul style="list-style-type: none"> <li>• Cannot provide continuous train track information</li> <li>• Accuracy of predicting train's arrival time impacted by train speed variance, upstream preemption distance, and presence of train stations, etc.</li> <li>• Availability of upstream preemption trigger cannot be guaranteed</li> </ul>

The most common existing train detection technology is the track circuitry-based warning system, including fixed distance and CWT systems (Datta et al., 2013; Korve, 1999). A track circuit can provide train information (speed, length, etc.) when a train enters the range of circuit loops; however, this signal must be retrieved from the railroad control system. In practice, it is difficult to install a communication link with railroad companies that have the primary responsibility for operating track circuits. A GPS in-train system can provide more accurate information of train track through a wireless network in real time; however, this technology has the same problem as the track circuit system in practice.

---

Roadside train detection technologies (radar or video) have been used in traffic control systems. The major advantage of these technologies is that their installation or operations are fully independent of the railroad control system. However, due to the needs of installing new devices in field, their initial and service costs are expensive.

Instead of installing train detectors, activations or deactivations of the preemptions at upstream intersections along the railway corridor can be used as an indication of an approaching train and the trigger of pre-preemptions at the target intersections. ETA can be calculated based on the distance between the two upstream preempted intersections and the time differences between their preemptions. Such strategies are particularly feasible if the central signal control software can receive notices of preemption activations and deactivations from the local controllers.

This method becomes an attractive alternative for train detection because it does not need to install new devices or apply new permissions from rail companies. In this study, this methodology is adopted. However, some limitations should be considered:

- This method relies on the availability of preemption trigger signals at upstream signalized intersections along railroads. In Florida, setup of preemption follows the standards defined in the MUTCD (within the range of 200 ft to railroad crossings). Thus, the number of preempted intersections is very limited.
- Even if upstream preempted intersections are available, with an increase in the distance between the upstream intersections and the downstream target intersection, the accuracy of ETA decreases due to the variance of train speed.

### **5.3 Prediction Subsystem**

Once the detection system perceives a train approaching, the prediction subsystem starts to predict the train's arrival time at the target railroad at-grade crossing in order to activate pre-preemption at a proper time. The accuracy (error) of the train's arrival time is decided by the following factors:

- Detector technology
- Prediction algorithm
- Detector location with respect to target railroad crossing
- Train speed variance

CWT systems, assuming that train speed remains constant, are widely used to predict train's arrival time for traffic signal control at at-grade crossings. However, the predicted time is always subject to error due to train speed variance. With an increase in the distance

of the detector to the target crossing, the accuracy tends to decrease. The accuracy of train's arrival time forecast can be improved by selecting robust detector technologies (continue detection, multi-point detection, etc.) or an advance prediction algorithm (regression, Artificial Neural Networks, etc.). These advance technologies or prediction algorithms may need additional devices and increase implementation cost.

In this study, the prediction logic of ETA based on upstream preemption triggers is described using an example, as shown in Figure 5-2.

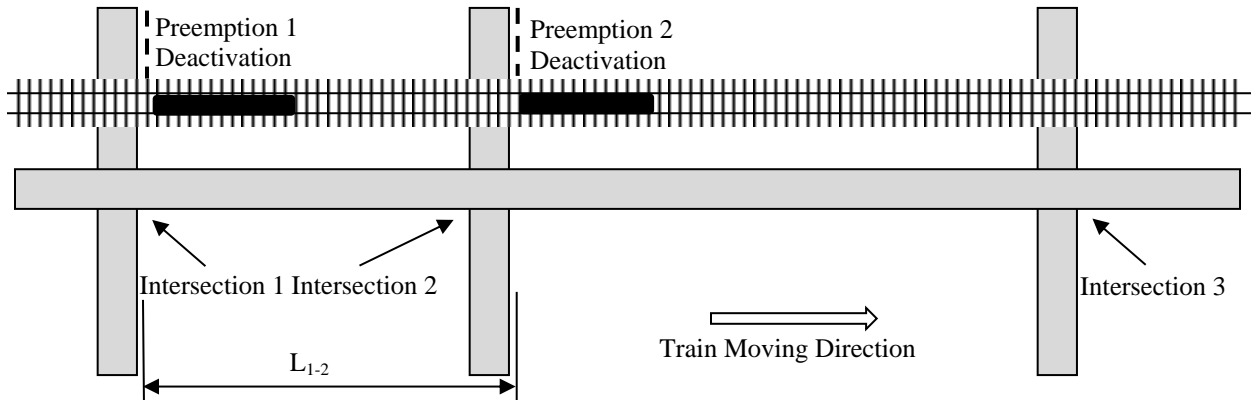

**Figure 5-2 Train Speed Calculation Based on Two Upstream Preemptions**

Assuming the pre-preemption at intersection 3 is triggered by the deactivation of the intersection 2 preemption, the train speed can be calculated as follows:

$$V_t = \frac{L_{1-2}}{T_{d2-d1}} \quad (5-1)$$

where  $V_t$  is the speed of an approaching train and  $L_{1-2}$  is the distance between intersections 1 and 2, and  $T_{d2-d1}$  in Equation 5-1 equals the time difference between the deactivations of preemptions at intersections 1 and 2.

As shown in Figure 5-3, the available time ( $T_{ppe}$ ) for the pre-preemption at intersection 3 equals the time difference between the preemption deactivation at intersection 2 and the preemption activation at intersection 3. Therefore, the following relationship can be established:

$$L_{2-3} = (T_{ppe} + CWT_3) \times V_t + L_{w3} + L_t \quad (5-2)$$

where  $L_{2-3}$  is the distance between intersection 2 and 3;  $T_{ppe}$  represents the available time that can be used to serve the pre-preemption strategies;  $CWT_3$  is the constant warning time duration at intersection 3;  $L_{w3}$  equals the width of intersection 3; and  $L_t$  is the train length.

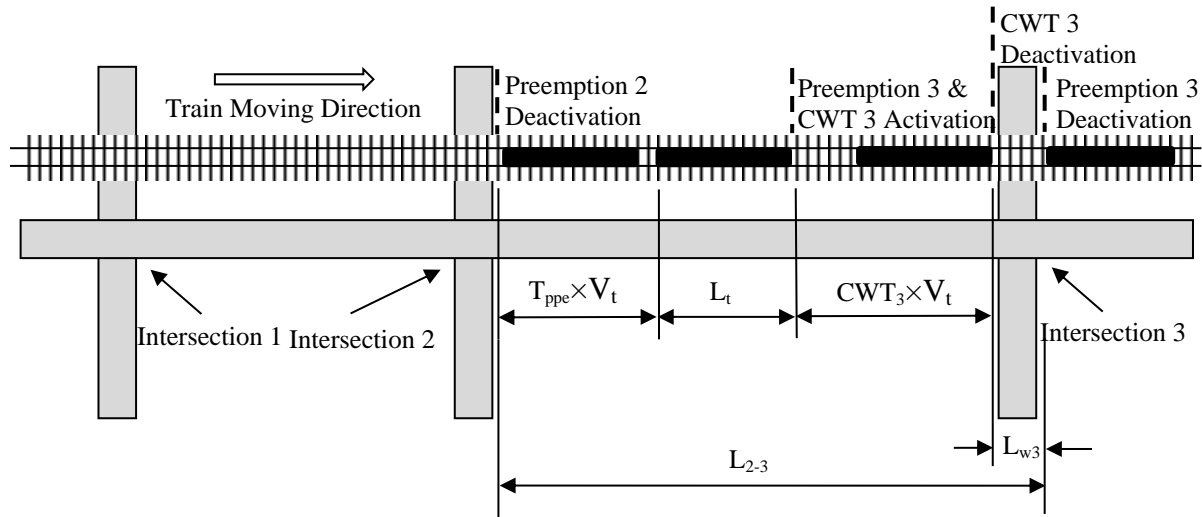
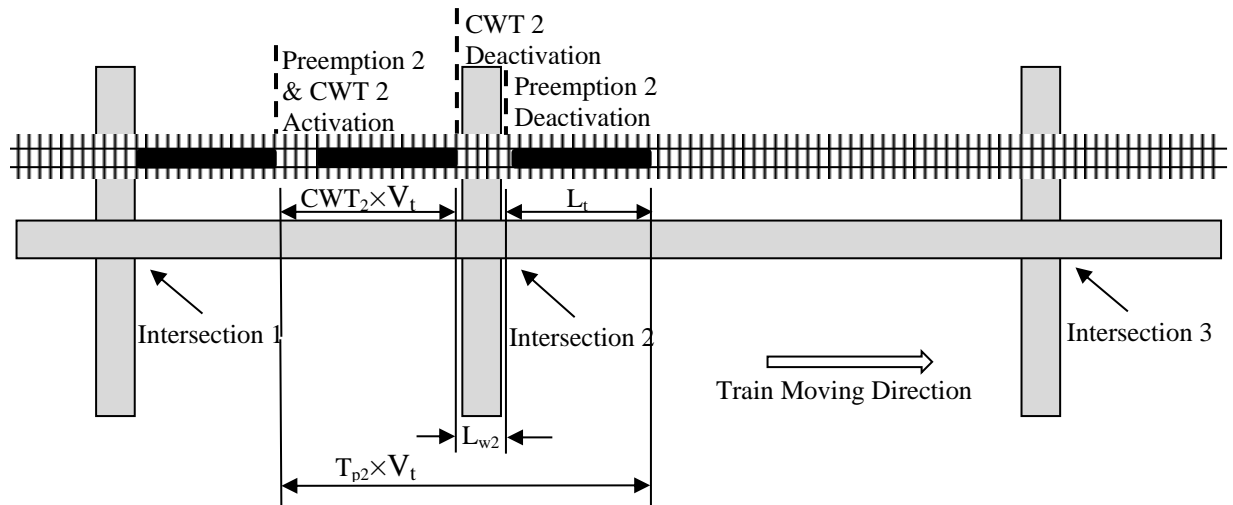

**Figure 5-3 Calculation of Available Time for Pre-preemption**

As shown in Figure 5-4, the train length can be extracted based on the time difference between the activation and deactivation of preemption at intersection 2. The equation to calculate the train length is presented below:

$$L_t = (T_{p2} - CWT_2) \times V_t - L_{w2} \quad (5-3)$$

where  $T_{p2}$  is the preemption time duration at intersection 2;  $CWT_2$  indicates the constant warning time duration at intersection 2; and  $L_{w2}$  equals the width of intersection 2.



**Figure 5-4 Train Length Calculation Based on Upstream Preemptions**

Combining Equations 5-1, 5-2, and 5-3, the available time for pre-preemption can be calculated by Equation 5-4:

$$T_{ppe} = \frac{(L_{2-3} - L_{w3} + L_{w2}) \times T_{d2-d1}}{L_{1-2}} - T_{p2} + CWT_2 - CWT_3 \quad (5-4)$$

Although the theory that available time can also be calculated using the relationship between the activations of upstream preemptions, instead of using the deactivations at the two intersections as it used in the equations above, the uncertainty of the train position at the time of preemption activations due to the variation of the train speeds makes it difficult to obtain a reliable outcome.

## 5.4 Control Subsystem

The control subsystem is the core module of the pre-preemption system. The operation of the control subsystem is activated when the predicted train's arrival time (ETA) is equal to or less than a critical value (up to the advance warning time). Once the control subsystem is initialized, the normal phases at target intersections will be interrupted, and one or more pre-preemption phases will be conducted, including:

- Before Train's arrival – The pre-preemption system provides "extra" green time before train's arrival to special movements. The "extra" green time could clear the traffic volumes blocked during train passing the crossing in order to mitigate congestion during train blockage. In this report, the "extra" green time is referred to as congestion-clearance or pre-preemption phases. These special phases are

---

assigned to the “conflicting” movements or a subset of them based on the optimization objectives of the pre-preemption strategy.

- During Train Blockage – During the period of a train passing a crossing, the “conflicting” movements are blocked by a train. Thus, the general strategy is to assign green time to the movements that do not conflict with the train during this period. If the intersection is far from the crossing, the traffic signal may operate in a normal mode since the storage space between the crossing and the intersection is large enough.
- After Train Blockage – After the train leaves the railroad crossing, the general strategy is to assign green time to the movements blocked by the train movement for dissipating the queues that occurred in the train passing duration as soon as possible.

At the preempted intersections, the pre-preemption strategy is an extension of the traditional preemption strategy. In general, the two operations (pre-preemption and preemption) have independent triggers: the preemption operation is always assigned the highest priority, followed by the pre-preemption operation. The pre-preemption operation starts earlier than the preemption operation; the preemption operation terminates the pre-preemption operation at any time when the traffic controller receives a preemption trigger signal. Afterwards, the preemption operation conducts the track clearance phase (before train’s arrival), dwell phases (during train blockage), and exit phases (after train blockage), respectively.

At a non-preempted intersection next to a crossing, the pre-preemption strategy can be operated individually. The congestion-clearance phases (pre-preemption phases) are triggered and operated in the same manner as at the preempted intersection. The following phases (track clearance, dwell, and exit) are optional phases, according to traffic and geometric conditions. They can be triggered by the release of the pre-preemption phases or disabled at this intersection.

At the intersections that are close to but not next to a crossing, the pre-preemption strategy is used for coordinated congestion clearance purposes. Thus, the pre-preemption strategy includes the “extra” green time assigned to the coordinated phase only.

As summarized in Chapter 2, two ideas have been developed for optimizing signal operations before preemption at the intersections adjacent to a railroad crossing: pre-timed (EWS) or dynamic (ITPS). Both of these algorithms do not consider coordination in clearing

---

congestion along a roadway corridor. In this study, a coordination-based pre-preemption strategy was developed to optimize the safety and operational performance of a roadway corridor intersecting railroad.

## **5.5 Coordinated Pre-preemption Strategy**

The basic idea of the coordinated pre-preemption strategy is to assign “extra” green time to the movements at several intersections along a roadway corridor that intersects a railroad before train’s arrival. The “extra” green time (congestion clearance phase) allows through traffic to be cleared on the arterial before train’s arrival. To maximize the opportunity, the “extra” green time should be coordinated at intersections along the roadway corridor. The pre-preemption phases work at a pre-timed mode because (1) it is the requirement of coordination and (2) it can easily be coded into existing traffic controllers. Except for the coordinated pre-preemption phase, the coordinated pre-preemption strategy may provide non-coordinated phases for clearing other movements before train’s arrival if there is a potential for congestion due to train blockage. The phases of track clearance, dwell phases, and exit phases should be considered at the intersection next to the crossing if the storage space between the intersection and the crossing is short, even if the intersection is not preempted.

Examples of the coordinated pre-preemption strategy are shown in Figure 5-5, Figure 5-6, Figure 5-4, Figure 5-7, and Figure 5-8.

- As shown in Figure 5-5, a railroad intersects an arterial that carries heavy vehicle traffic on westbound (WB). Severe congestion and long queues may occur along this direction, caused by a train passing the crossings during peak hours.
- Three signalized intersections (Intersections A, B, and C) along the arterial are impacted by the crossing. All the three intersections have standard NEMA 8 phases.
- Intersection B is a preempted intersection, and the distance between this intersection and the crossing is less than 200 feet. The track clearance phase is Phase 1-6. Dwell phases are 3-8, 4-8, and 5 in an actuated manner. The exit phases are 1-6 and 2-6.
- The coordinated pre-preemption strategy provides “extra” green time for the through movement at the three intersections before train’s arrival. The congestion clearance phase is 2-6 in a coordinated manner: Phase 2-6 starts at the sequence of Intersection A → Intersection B → Intersection C.



- 
- The sequence of the coordinated pre-preemption is as follows (as shown in Figure 5-6) :
    - When pre-preemption is triggered by detecting a train approaching, the coordinated pre-preemption phase (Phase 2-6) is activated at Intersection A after a system delay.
    - After a given offset (Offset A-B), the coordinated pre-preemption phase (Phase 2-6) starts at Intersection B.
    - After a given offset (Offset A-C), the coordinated pre-preemption (Phase 2-6) starts at Intersection C.
    - When the coordinated pre-preemption phase is completed, traffic signals at Intersections A and C go back to normal phases.
    - When the preemption is triggered at Intersection B, the coordinated pre-preemption phase (Phase 2-6) is terminated and the track clearances phase (Phase 1-6) is activated.
    - When the train arrives at the crossing, the track clearance phase is terminated and the dwell phases start at Intersection B at a sequence of Phase 3-7 -> Phase 4-8 -> Phase 5. Dwell phases work in an actuated manner.
    - When the train leaves the crossing, dwell clearance phases are terminated and exit phases start at Intersection B at a sequence of Phase 1-5 -> Phase 2-6.
    - After the exit phases, the traffic signal at Intersection B goes back to a normal phase.
  - If the left-turn demand on westbound Intersection B is too high and exceeds the left bay during the period of congestion clearance, Phase 2-5 for clearing this traffic will be added as a coordinated pre-preemption phase before Phase 2-6, as shown in Figure 5-7.

If traffic demand for the movements on minor roads (e.g., the left-turn movement on northbound Intersection B, as shown in Figure 5-5) is high, a clearance phase (Phase 3-7 or Phase 4-7) may be provided as the first pre-preemption phase (non-coordinated) before the coordinated pre-preemption phases, as shown in Figure 5-8.

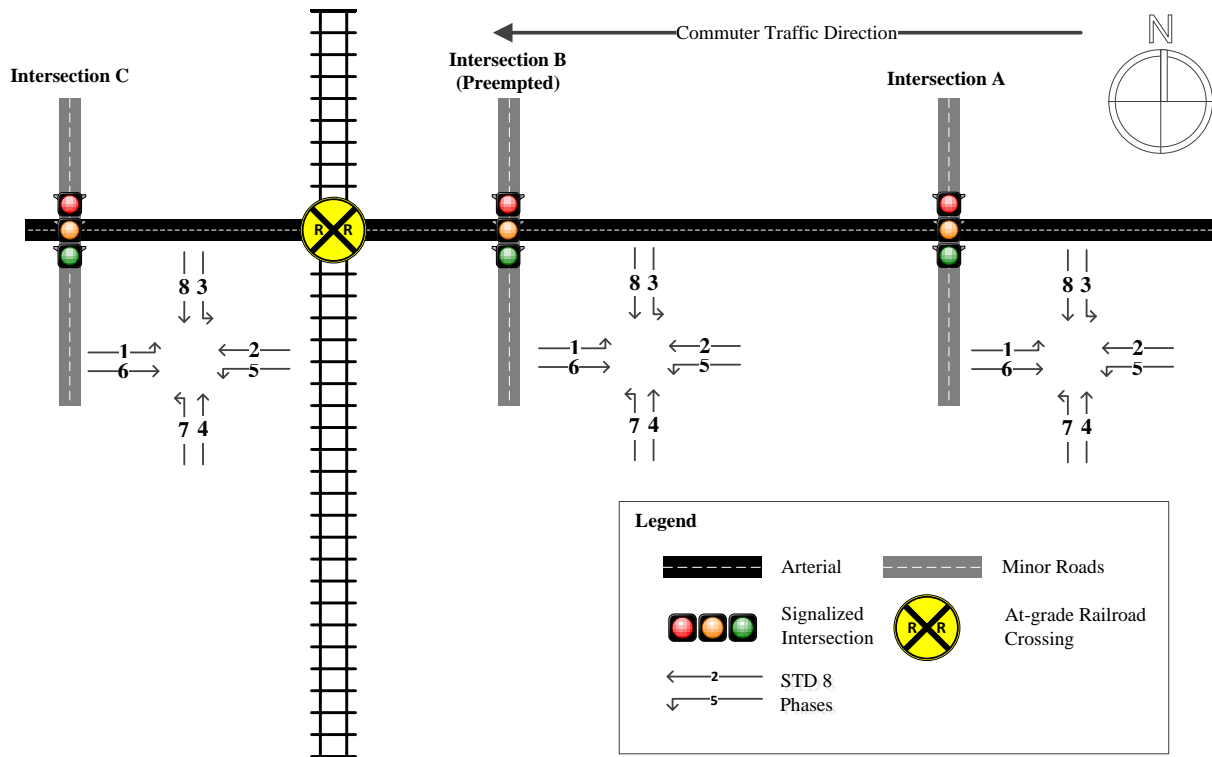

**Figure 5-5 Example Site for Pre-preemption Strategy**

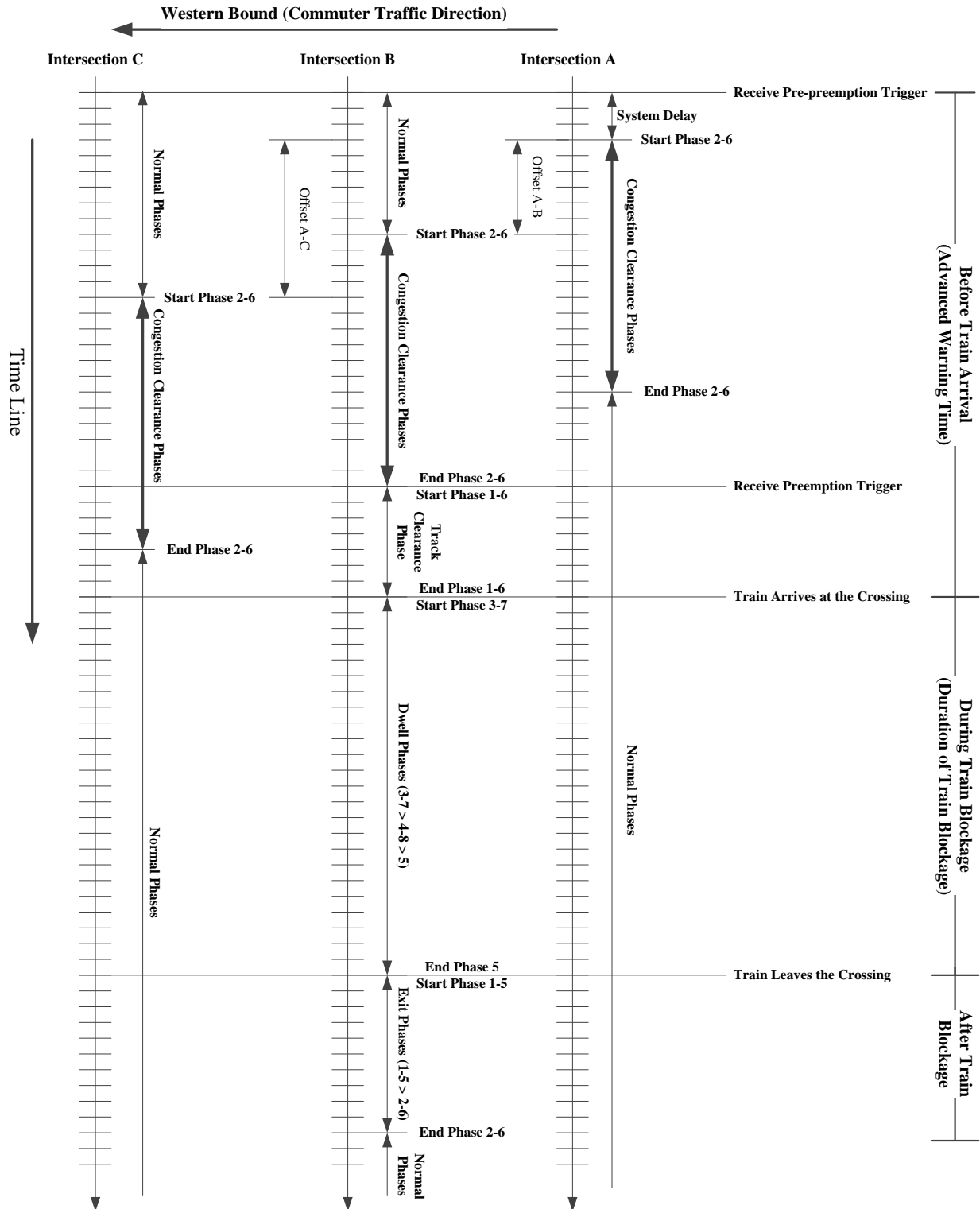

**Figure 5-6 Pre-preemption Timeline  
(one coordinated pre-preemption phase at Intersection B)**

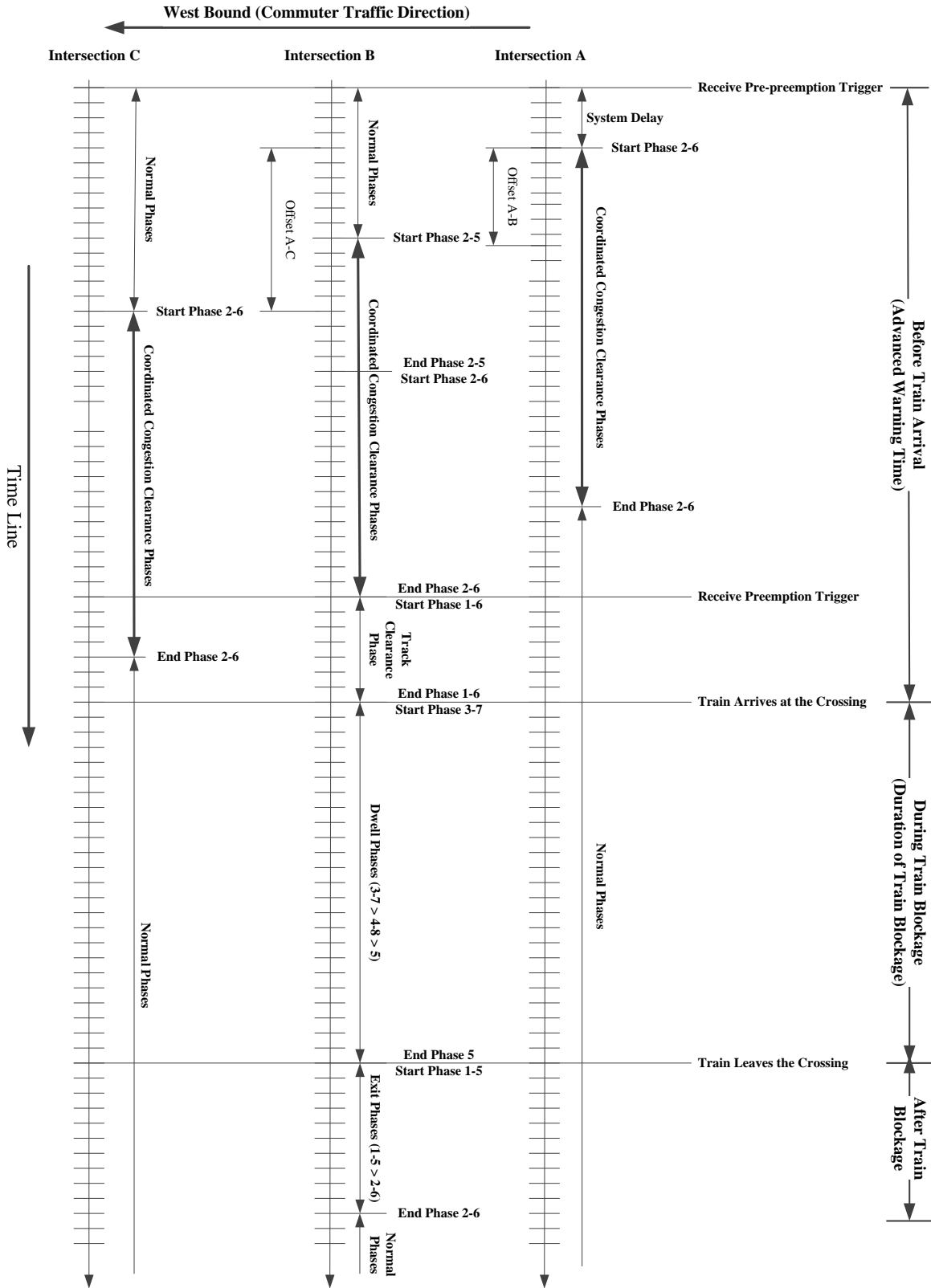

**Figure 5-7 Pre-preemption Time Line  
(two coordinated pre-preemption phases at Intersection B)**

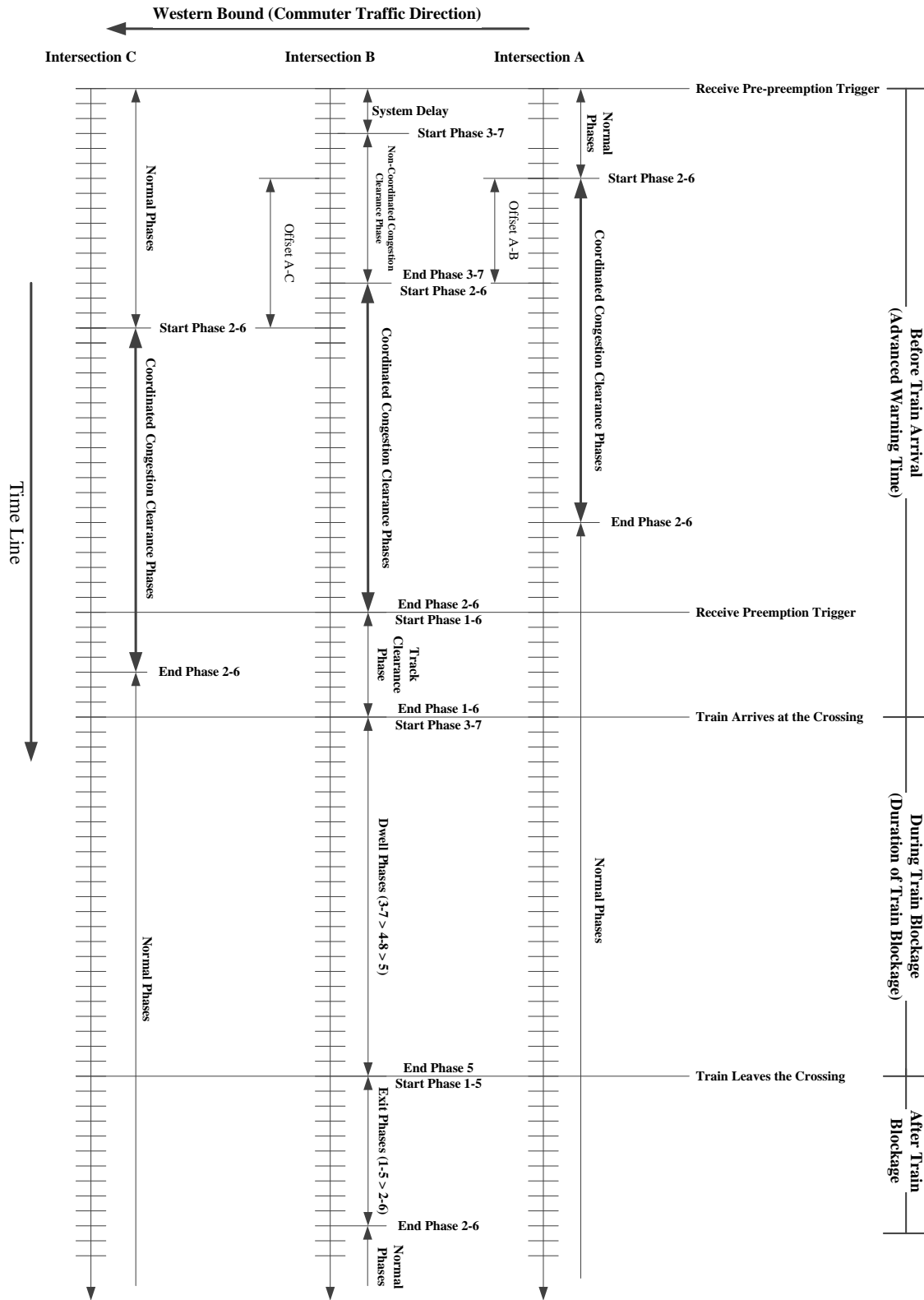

The design of pre-preemption strategy should consider the following elements:

- length of coordinated congestion clearance phase
- offset of coordinated congestion clearance phase
- number and sequence of coordinated and non-coordinated clearance phases at the preempted intersection

The sum of offset, congestion clearance phases (coordinated and non-coordinated), and track clearance phase cannot exceed the advance warning time (AWT). The optimization of the congestion clearance phases (number, length, offset, and sequence) should considering commuter traffic demand, traffic demand of minor movements blocked by train, site geometry, and duration of train blockage.

## 5.6 Comparison

A comparison between the coordination pre-preemption strategy and other pre-preemption strategies is shown in Table 5-2.

**Table 5-2 Summary of Pre-preemption Strategies**

Strategy	Logic	Required Preemption	Control Type	Arterial Coordination	Compatibility with Standard Traffic Controller	Effectiveness
ITPS-based	Complex	Yes	Actuated	No	Poor (additional logic module may be needed)	Good at individual intersection
EWS	Simple	Yes	Pre-timed	No	Excellent	Unproved
Coordinated Pre-preemption	Simple	No	Pre-timed	Yes	Excellent	Good for arterial and network

---

## **6 DEVELOPMENT OF SIMULATION MODEL**

This chapter describes the VISSIM-based simulation model developed in this study for evaluating safety and operational performance of the coordinated pre-preemption strategy. The first section introduces three control sections for model development. The second section explains the procedure of data collection and data reduction. The procedure of model development is described in Section 3; the last section illustrates the methodology of data analysis.

### **6.1 Site Selection**

#### **6.1.1 Selection Criteria**

The research objective of this study requires a set of sites with different geometric and traffic conditions to testify the coordinated pre-preemption strategy. A careful selection of study sites (control sections) along the railroad corridors in south Florida area was made according to the following criteria:

- Each control section contains one railroad corridor.
- Roadway corridors (arterials) intersect the railroad corridor at at-grade railroad crossings.
- Roadway corridors have high traffic volume during peak periods.
- Roadway corridors and adjacent signalized intersections are impacted by the at-grade railroad crossings.
- Preempted intersections are available in the control section.
- The ATMS.now system is available at the sites.

Traffic volume on the roadway corridor had to be sufficiently high to evaluate the performance measures before and after the coordinated pre-preemption strategy. Corridors with low traffic volume were not considered potential sites because of their relatively low congestion level and minor impact from the pre-preemption strategy. In this study, upstream preemptions were required as the trigger for pre-preemption. Therefore, one of the main requirements of selecting sites was to make sure that the upstream preemption was available. Also, the selected sites had to be under the coverage of the ATMS.now system.

#### **6.1.2 Selected Control Sections**

Based on these criteria, three control sections were selected from the road network in Broward County, Florida. Section I contains six at-grade railroad crossings along the FEC

Railway. Six arterials intersecting the FEC rail corridor at these crossings, from SW 24<sup>th</sup> St (South) to NE 13<sup>th</sup> St (North). In total, 18 signalized intersections next to or impacted by the crossings were included in this section, and one was preempted (W Sunrise Blvd @ N Flagler Dr). Table 6-1 summarizes the configuration of Section I. Figure 6-1 shows the control sections.

**Table 6-1 Summary of Control Section I**

<b>FDOT Crossing ID</b>	<b>Crossing Road</b>	<b>Intersection</b>	<b>Distance to Crossing (ft)</b>	<b>Intersection ID</b>	<b>Preempted (Y/N)</b>	<b>Coordinated (Y/N)</b>
272567	SE 24 <sup>th</sup> St	S Andrew Ave @ SE 24th St	570	2129	N	Y
		SW 4th Ave @ SW 24th St	1562	2142	N	Y
272564	SE 17 <sup>th</sup> St	S Andrew Ave @ SE 17th St	269	2060	N	Y
		SW 4th Ave @ SW 17th St	1140	2099	N	Y
272562	Davie Blvd	S Andrew Ave @ Davie Blvd	710	2095	N	Y
		SW 4th Ave @ Davie Blvd	1000	2089	N	Y
272556	W Broward Blvd	Brickell Ave @ W Broward Blvd	285	2133	N	Y
		S Andrew Ave @ W Broward Blvd	660	2054	N	Y
		NW 5th Ave @ W Broward Ave	992	2288	N	Y
		NW 7 <sup>th</sup> Ave @ W Broward Ave	1600	2071	N	Y
272549	W Sunrise Blvd	N Flagler Dr @ W Sunrise Blvd	185	2101	Y	Y
		N Federal Hwy @ W Sunrise Blvd	876	2027	N	Y
		NE 9 <sup>th</sup> Ave @ W Sunrise Blvd	1330	2208	N	Y
		NE 10 <sup>th</sup> Ave @ W Sunrise Blvd	1636	2209	N	Y
		NE 4th Ave @ W Sunrise Blvd	491	2138	N	Y
272548	NE 13th St	NE 15th Ave @ NE 13th St	1436	2032	N	N/A
		NE 7th Ave @ NE 13th Ave	1140	2167	N	N/A



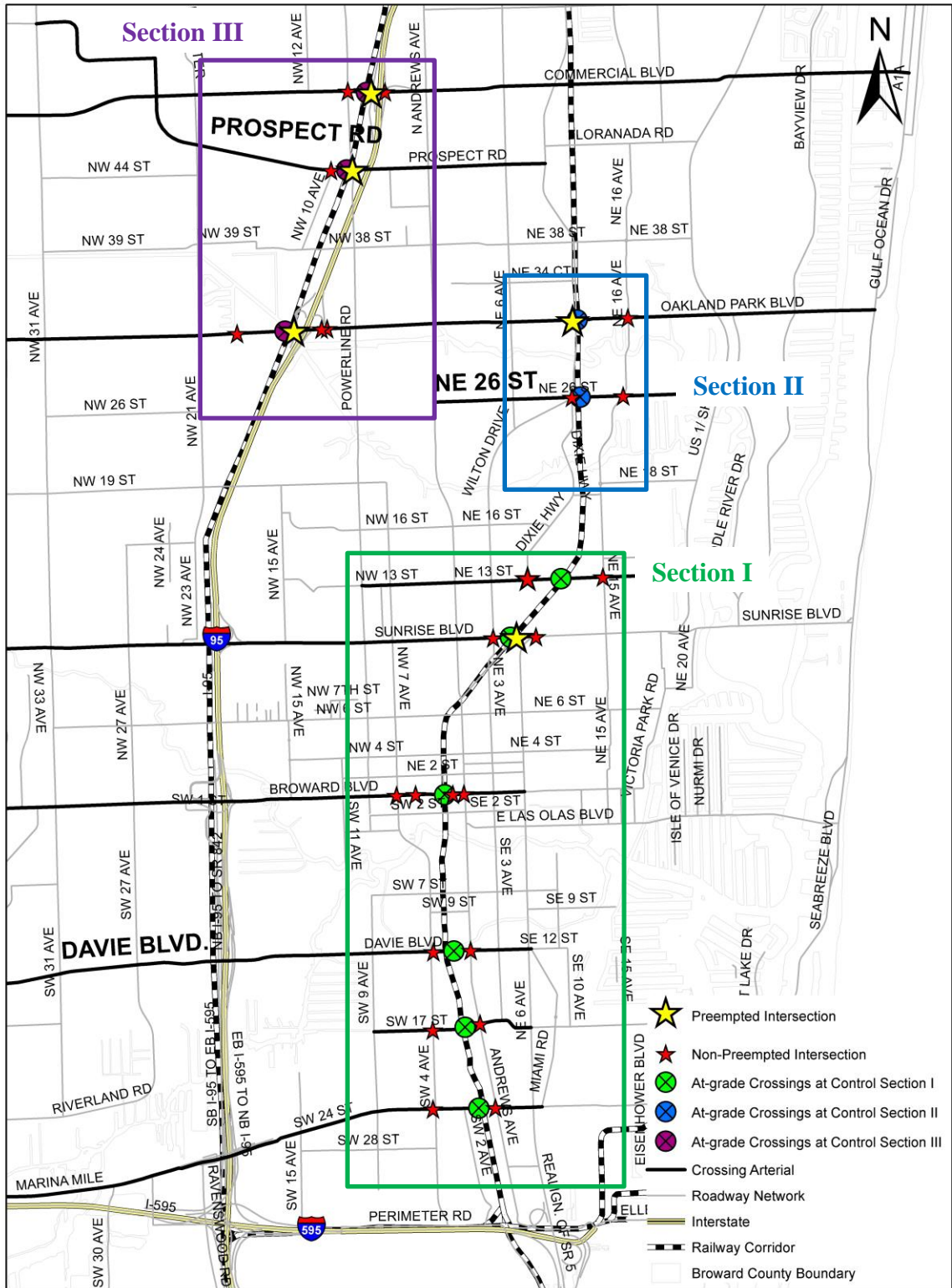

**Figure 6-1 Control Sections in Broward County, Florida**

Section II contains two at-grade railroad crossings along the FEC corridor. Two arterials (NE 26<sup>th</sup> St and Oakland Park Blvd) intersect the railroad corridor at the two crossings. Four signalized intersections are included in this control section. Table 6-2 gives the configuration of Section II.

**Table 6-2 Summary of Control Section II**

<b>Crossing ID</b>	<b>Crossing Road</b>	<b>Intersection</b>	<b>Distance to Crossing (ft)</b>	<b>Intersection ID</b>	<b>Preemption (Y/N)</b>	<b>Coordinated (Y/N)</b>
272545	NE 26 <sup>th</sup> St	NE 15th/16th Ave @ NE 26th St	1440	2204	N	N/A
		N Dixie Hwy @ NE 26th St	279	2201	N	N/A
272544	E Oakland Park Blvd	NE 16th Ave @ E Oakland Park Blvd	1737	1112	N	Y
		N Dixie Hwy @ E Oakland Park Blvd	84	1113	Y	Y

The summary of Section III is given in Table 6-3. Three at-grade crossings are contained in this section from Oakland Park Blvd (South) to Commercial Blvd (North). The rail corridor is parallel to an interstate (I-95), and two preempted intersections connect ramps of I-95 at E Oakland Park Blvd and Commercial Blvd. Another preempted intersection is NW 9th Ave at W Prospect Rd.

**Table 6-3 Summary of Control Section III**

Crossing ID	Crossing Road	Intersection	Distance to Crossing (ft)	Intersection ID	Preemption (Y/N)	Coordinated (Y/N)
628191	E Oakland Park Blvd	I-95 EXIT 31 SB OFF Ramp @ E Oakland Park Blvd	311	1089	Y	Y
		I-95 EXIT 31 NB OFF Ramp @ E Oakland Park Blvd	855	1089	N	Y
		I-95 EXIT 31 NB ON Ramp @ E Oakland Park Blvd	1367	1089	N	Y
		NW 18th Ave @ E Oakland Park Blvd	1642	1193	N	N/A
628188	W Prospect Rd	NW 9th Ave @ W Prospect Rd	200	1105	Y	Y
		NW 10th Ave @ W Prospect Rd	526	1545	N	Y
628186	W Commercial Blvd	I-95 EXIT 32 SB Ramps @ W Commercial Blvd	200	1088	Y	Y
		I-95 EXIT 32 NB Ramps @ W Commercial Blvd	654	1088	N	Y
		NW 9th Ave @ W Commercial Blvd	644	1132	N	Y

## 6.2 Data Collection

Various data were collected for the selected control sections, including site geometries, vehicle traffic, train information, etc.

### 6.2.1 Site Geometries

Geometric information was collected for each control section at three levels: railway, arterial, and intersection. Researchers reviewed FDOT GIS maps and high quality aerial photos to retrieve the geometric information. Collected data and associated data sources are listed in Table 6-4.

---

**Table 6-4 Data Collection at Control Sections**

<b>Object</b>	<b>Collected Data</b>	<b>Source</b>
Railway	Number of tracks	Aerial Photo
	Track width	Aerial Photo
	Distance between at-grade crossings along railroad corridor	FDOT GIS Map
Arterial	Number of lanes	FDOT GIS Map
	Lane width	FDOT GIS Map
	Speed limit	FDOT GIS Map
	Distance between intersections along arterial	FDOT GIS Map
	Length of arterial	FDOT GIS Map
Intersection	Lane configuration	Aerial Photo
	Length of storage bay	Aerial Photo
	Location of traffic signal	Aerial Photo
	Location of loop	Aerial Photo
	Distance to railroad crossing	FDOT GIS Map

### 6.2.2 Traffic Data

To build simulation models, the counts of turning movements at the selected intersections were needed in this study. Due to time and budget limitations, data collection in the field was not conducted in this study. Researchers retrieved the intersection turning movement counts from existing data sources, such as from FDOT, Broward County, and others. All traffic data were collected during peak hours (7:00–9:00 AM, 11:00 AM–1:00 PM, and 4:00–6:00 pm) for three days. The time span was four years (2009, 2010, 2011, and 2012). Figure 6-2 is an example of the traffic count form.

### 6.2.3 Traffic Signal Data

Traffic signal information for each selected intersection was extracted from the Broward County traffic engineering database. Figure 6-3 shows an example of actuated traffic signal timing sheet. Each timing sheet contains the following information:

- Identification Information – intersection ID, controller type, intersection name
- Vehicle Phase Information – minimum green time, yellow clearance, all red clearance, vehicle extension, maximum green time
- Pedestrian Phase Information – walk time, pedestrian clearance
- Preemption Information – enable or not; preemption sequence, phase timing

The coordination timing data for the coordinated intersections were retrieved from the Broward County Traffic Engineering database, including coordinated phase number, cycle length, and offset time. Figure 6-4 gives an example of the coordination time table.

Broward County Traffic Engineering  
 2300 W. Commercial Blvd  
 Fort Lauderdale, FL 33309

File Name : 9030028 3-31-2009  
 Site Code : 00000000  
 Start Date : 3/31/2009  
 Page No : 1

CITY: FT LAUDERDALE  
 LOCATION: DAVIE BLVD + SW 4 AVE  
 COMMENTS: SBRT + SB THRU

Groups Printed- 1 - Unshifted

Start Time	SW 4 AVE Northbound				SW 4 AVE Southbound				DAVIE BLVD Eastbound				DAVIE BLVD Westbound				Int. Total
	Left	Thru	Right	Peds	Left	Thru	Right	Peds	Left	Thru	Right	Peds	Left	Thru	Right	Peds	
Factor	1.0	1.0	1.0	1.0	1.0	1.0	1.0	1.0	1.0	1.0	1.0	1.0	1.0	1.0	1.0	1.0	
07:00 AM	0	0	0	0	0	45	15	0	0	0	0	0	0	0	0	0	60
07:15 AM	0	0	0	0	0	45	18	0	0	0	0	0	0	0	0	0	63
07:30 AM	0	0	0	0	0	44	23	0	0	0	0	0	0	0	0	0	67
07:45 AM	0	0	0	0	0	77	30	0	0	0	0	0	0	0	0	0	107
Total	0	0	0	0	0	211	86	0	0	0	0	0	0	0	0	0	297
08:00 AM	0	0	0	0	0	71	27	0	0	0	0	0	0	0	0	0	98
08:15 AM	0	0	0	0	0	64	30	0	0	0	0	0	0	0	0	0	94
08:30 AM	0	0	0	0	0	53	36	0	0	0	0	0	0	0	0	0	89
08:45 AM	0	0	0	0	0	49	23	0	0	0	0	0	0	0	0	0	72
Total	0	0	0	0	0	237	116	0	0	0	0	0	0	0	0	0	353
11:00 AM	0	0	0	0	0	59	12	0	0	0	0	0	0	0	0	0	71
11:15 AM	0	0	0	0	0	50	26	0	0	0	0	0	0	0	0	0	76
11:30 AM	0	0	0	0	0	42	26	0	0	0	0	0	0	0	0	0	68
11:45 AM	0	0	0	0	0	59	18	0	0	0	0	0	0	0	0	0	77
Total	0	0	0	0	0	210	82	0	0	0	0	0	0	0	0	0	292
12:00 PM	0	0	0	0	0	61	22	0	0	0	0	0	0	0	0	0	83
12:15 PM	0	0	0	0	0	62	33	0	0	0	0	0	0	0	0	0	95
12:30 PM	0	0	0	0	0	66	17	0	0	0	0	0	0	0	0	0	83
12:45 PM	0	0	0	0	0	62	29	0	0	0	0	0	0	0	0	0	91
Total	0	0	0	0	0	251	101	0	0	0	0	0	0	0	0	0	352
04:00 PM	0	0	0	0	0	58	23	0	0	0	0	0	0	0	0	0	81
04:15 PM	0	0	0	0	0	68	54	0	0	0	0	0	0	0	0	0	122
04:30 PM	0	0	0	0	0	37	37	0	0	0	0	0	0	0	0	0	74
04:45 PM	0	0	0	0	0	90	61	0	0	0	0	0	0	0	0	0	151
Total	0	0	0	0	0	253	175	0	0	0	0	0	0	0	0	0	428
05:00 PM	0	0	0	0	0	65	39	0	0	0	0	0	0	0	0	0	104
05:15 PM	0	0	0	0	0	113	70	0	0	0	0	0	0	0	0	0	183
05:30 PM	0	0	0	0	0	185	62	0	0	0	0	0	0	0	0	0	247
05:45 PM	0	0	0	0	0	140	82	0	0	0	0	0	0	0	0	0	222
Total	0	0	0	0	0	503	253	0	0	0	0	0	0	0	0	0	756
Grand Total	0	0	0	0	0	1665	813	0	0	0	0	0	0	0	0	0	2478
Apprch %	0.0	0.0	0.0	0.0	0.0	67.2	32.8	0.0	0.0	0.0	0.0	0.0	0.0	0.0	0.0	0.0	
Total %	0.0	0.0	0.0	0.0	0.0	67.2	32.8	0.0	0.0	0.0	0.0	0.0	0.0	0.0	0.0	0.0	

Figure 6-2 Example of Intersection Movement Counts



Table	Param	Split Expanded 1	Split Expanded 2	Split Expanded 3
1	Time	30	60	48
1	Mode	NON	MxP	NON
1	Coord Phase	OFF	ON	OFF
2	Time	25	70	44
2	Mode	NON	MxP	NON
2	Coord Phase	OFF	ON	OFF
3	Time	24	78	29
3	Mode	NON	MxP	NON
3	Coord Phase	OFF	ON	OFF
4	Time	18	72	19
4	Mode	NON	MxP	NON
4	Coord Phase	OFF	ON	OFF

Pattern	Cycle Time	Offset Time	Split Number	Seq Number
Pattern 1	0	0	0	1
Pattern 2	160	77	2	1
Pattern 3	160	90	3	1
Pattern 4	160	12	4	1
Pattern 5	0	0	0	1
Pattern 6	0	0	0	1
Pattern 7	0	0	0	1
Pattern 8	0	0	0	1
Pattern 9	0	0	0	1
Pattern 10	0	0	0	1
Pattern 11	0	0	0	1
Pattern 12	180	32	12	1
Pattern 13	180	73	13	1
Pattern 14	180	40	14	1
Pattern 15	160	90	15	1

**Figure 6-4 Example of Coordination Timing Form**

#### 6.2.4 Train Traffic Data

In addition to vehicle traffic information, the following train traffic information was needed to evaluate the performance of the proposed pre-preemption strategy:

- Duration of a train passing an at-grade railroad crossing
- Headway between successive trains
- Speed distribution of trains
- Train length

However, the information was difficult to obtain from the railroad companies (FEC, CSX). Therefore, preemption logs retrieved from the Broward County ATMS.now system were used to estimate train traffic data. The methodology was introduced in Chapter 4. Figure 6-5 is

an example of preemption log. Event (Failure) 61 represents the start of a preemption activity, and Event (Failure) 60 indicates the end of the preemption.

N Flagler Dr @ W Sunrise Blvd				
Device	AssetID	Failure	FailDate	Time
CONTROLLER	2101	61	01-Jan-13	0: 7: 9
CONTROLLER	2101	60	01-Jan-13	0:12: 8
CONTROLLER	2101	61	02-Jan-13	3:53:31
CONTROLLER	2101	61	02-Jan-13	3:53:31
CONTROLLER	2101	60	02-Jan-13	3:54:57
CONTROLLER	2101	60	02-Jan-13	3:54:57
CONTROLLER	2101	61	02-Jan-13	9:48:51
CONTROLLER	2101	61	02-Jan-13	9:48:51
CONTROLLER	2101	60	02-Jan-13	9:49:54
CONTROLLER	2101	60	02-Jan-13	9:49:54
CONTROLLER	2101	61	02-Jan-13	13:35:38
CONTROLLER	2101	61	02-Jan-13	13:35:38

*(Failure: 61 – Preemption in Progress; 60 – Preemption Finished)*

**Figure 6-5 Example of Preemption Log**

## 6.3 Simulation Model Development

### 6.3.1 Selection of Traffic Simulation Package

In this study, simulation models were used to evaluate the safety and operational performance of the proposed pre-preemption strategies. There are several popular simulation packages available for modeling purposes, and each simulation model has its own strengths and weaknesses in terms of general modeling and performance measures. CORSIM provides the natural choice for simulation modeling purposes but has certain difficulties when implementing the logic module. SimTraffic is easy to use for field traffic engineers and is often used with SYNCHRO signal optimization software. However, the support of detailed output for vehicles information indicates difficulties for the current implementation. In this study, VISSIM as a full-featured microscopic traffic simulation modeling environment was chosen in consideration of the following factors:

- VISSIM has a powerful capability to create roadway and railroad networks in computers.
- VISSIM can simulate the behaviors of vehicles, pedestrians, and trains.



- VISSIM supports many functions of traffic signal operations, including traffic controllers, display traffic signals, vehicle/train detectors, and feedback mechanisms.
- VISSIM can develop user-defined traffic signal logics using the Vehicle Actuated Programming (VAP) module. This feature is very important to study non-standard traffic signal controls, such as pre-preemption strategies.

### 6.3.2 Procedure for Simulation Model Development

Micro-simulation models generate a significant amount of detail on network-wide and corridor-wide performance that are critical for conducting a before and after study. In this study, the VISSIM-based simulation models were developed to evaluate the safety and mobility impacts of the “pre-preemption” strategy. Three control sections in Broward County were selected for data collection and calibration. VAP language was used to code the “pre-preemption” algorithms using the VisVAP tool. Figure 6-6 illustrates the procedure of VISSIM-based model development.

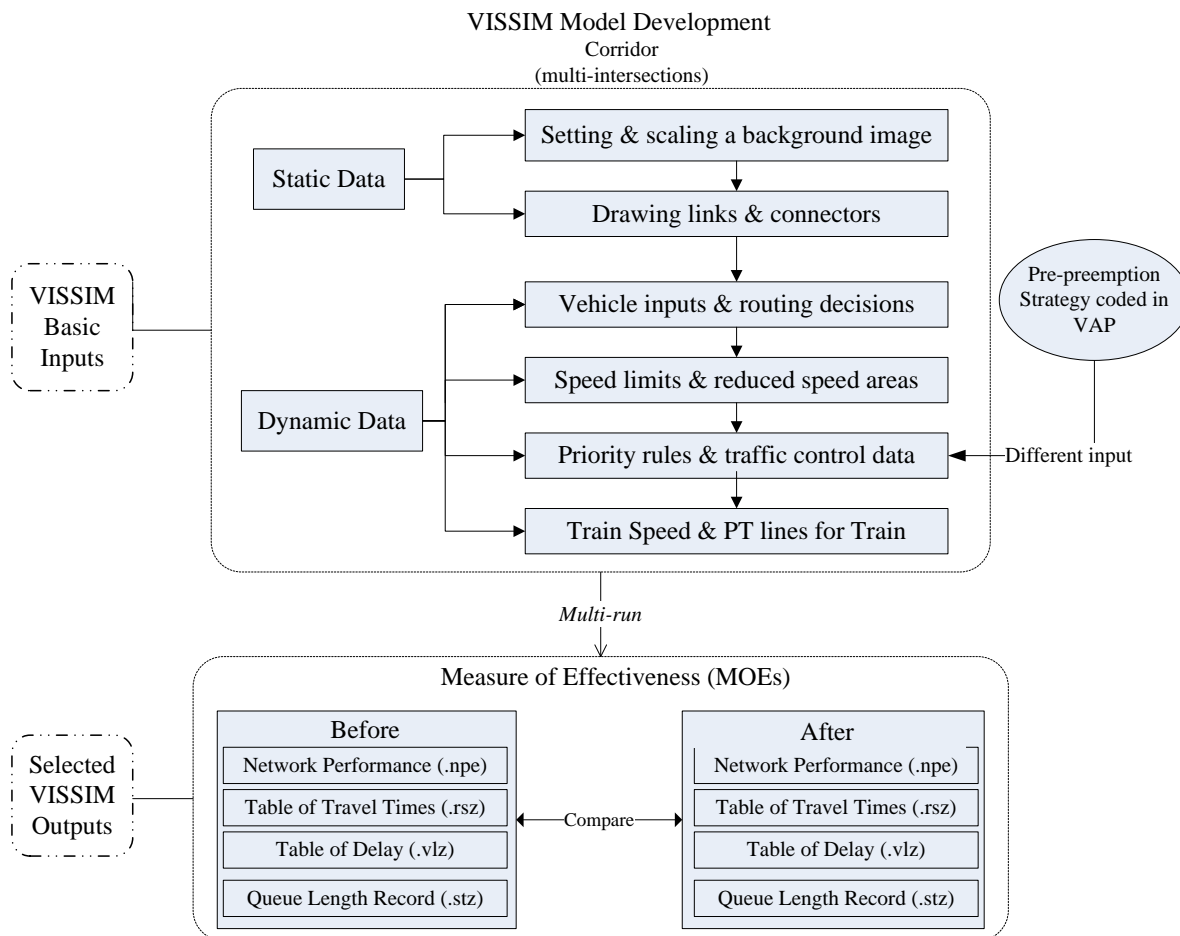

**Figure 6-6 Procedure of VISSIM-Based Simulation Model Development**

---

The accuracy of a traffic simulation model is mainly dependent on the quality of the vehicle modeling, such as the methodology of moving vehicles through the network. There are two kinds of data required for establishing a VISSIM network: (1) static data, representing the roadway infrastructure, which include links with start and end points, link length, width, grade, lane number, and location of stop lines, etc., and (2) dynamic data, required for traffic simulation applications, which includes traffic volumes for all links entering the network, and traffic volumes entering and for different turn directions at each intersection; vehicle routing, departure times and dwell times; and priority rules and signal timing plans at intersections, etc. The details of VISSIM data inputs for both static and dynamic data are discussed in the following subsections.

### 6.3.3 Coding Network

In this study, a high-resolution digital map (aerial photo) of Broward County in the Seamless Image Database (SID) format was imported and scaled into VISSIM as a background image. Researchers traced the roadway lanes and railroad tracks on the map to sketch the roadway network and railroad network by links and connectors. The properties of links and connectors, such as unique identifier, name/label, number of lanes, link length, behavior type, display type, and direction of traffic, were input by researchers.

Traffic volumes were coded for each link and each time interval in vehicles per hour, even if the time intervals were different by one hour. If the defined traffic volume exceeded the link capacity, the vehicles were stacked outside the network until space was available again. Besides the traffic volumes, the routing decisions were coded for turning movement counts in the VISSIM network. In this study, the static routes were used to define the percentages for different turning movements (i.e., left-turn, through, and right-turn) at intersections along the corridor.

In this study, the collected speed limits were assigned to each approach by using desired speed decisions. For turning vehicles, their speeds were reduced to 15 mph for left-turn and 9 mph (by defining reduced speed arrears on the turning connectors) for right-turn movements.

“Train” was coded as a new type of vehicle in the Vehicle Types window in VISSIM. Desired speed distributions were configured as minimum and maximum values for the desired train speed. A PT line was then used in VISSIM to model the train movement on a dedicated route, which served a fixed sequence according to a timetable time.

---

### 6.3.4 Coding Controllers

In this study, all traffic signal controllers (gate controller at railroad crossings and traffic signal controller at intersections) were coded in VAP using the VisVAP tool. The railroad crossing gate controller represents the operation of a crossing gate in the real world. A train-in detector was located at an upstream location 4,000 feet from the crossing. Once a train head is detected by the detector, the arrival time estimation module starts to judge if the ETA is equal to or less than the CWT (25 seconds). If answer is "yes," the crossing gate controller displays blockage phase (red signal to vehicle traffics at the crossing) to simulate "gate down." Once the train end is detected by a train-out detector located at the crossing, the signal returns to normal status (green signal to vehicle traffic at the crossing) to represent "gate up." The logic of the crossing gate controller is given in Figure 6-7.

Traffic signal controllers were coded in VISSIM for the combination of two different intersection types and three logic modes, as shown in Table 6-5. Normal mode represents the logic of a controller working at a normal status. For each selected intersection, the normal logic was coded according to the traffic timing table and/or coordination table collected in Broward County. The preempted mode, adding a preempted logic on a normal mode, represents the logic of a traffic controller working at preemption status. Only the intersections next to a crossing are valid for coding preempted logic.

At a preempted intersection, the pre-preemption logic is activated by the trigger signal from an upstream train-in detector after a given coordination offset time. The pre-preemption logic can be terminated by the activation of the preemption logic or the exhaustion of the predefined phase time and followed by the track clearance phase, dwell phase(s), and exit phase(s). A detailed description of the pre-preemption logic can be found in Figure 6-8.

For a non-preempted intersection next to a crossing (e.g., distance to the crossing  $\geq$  200ft), the pre-preemption mode adds the pre-preemption logic on the normal signal logic, as shown in Figure 6-9. The track clearance phase, dwell phase(s), and exit phase(s) are automatically activated after the pre-preemption phases, if these phases are applicable.

For an intersection adjacent to, but not next to, a crossing, the pre-preemption logic includes the coordinated pre-preemption phase only (Figure 6-10). Once the coordination phase is finished, the controller will return to normal status.

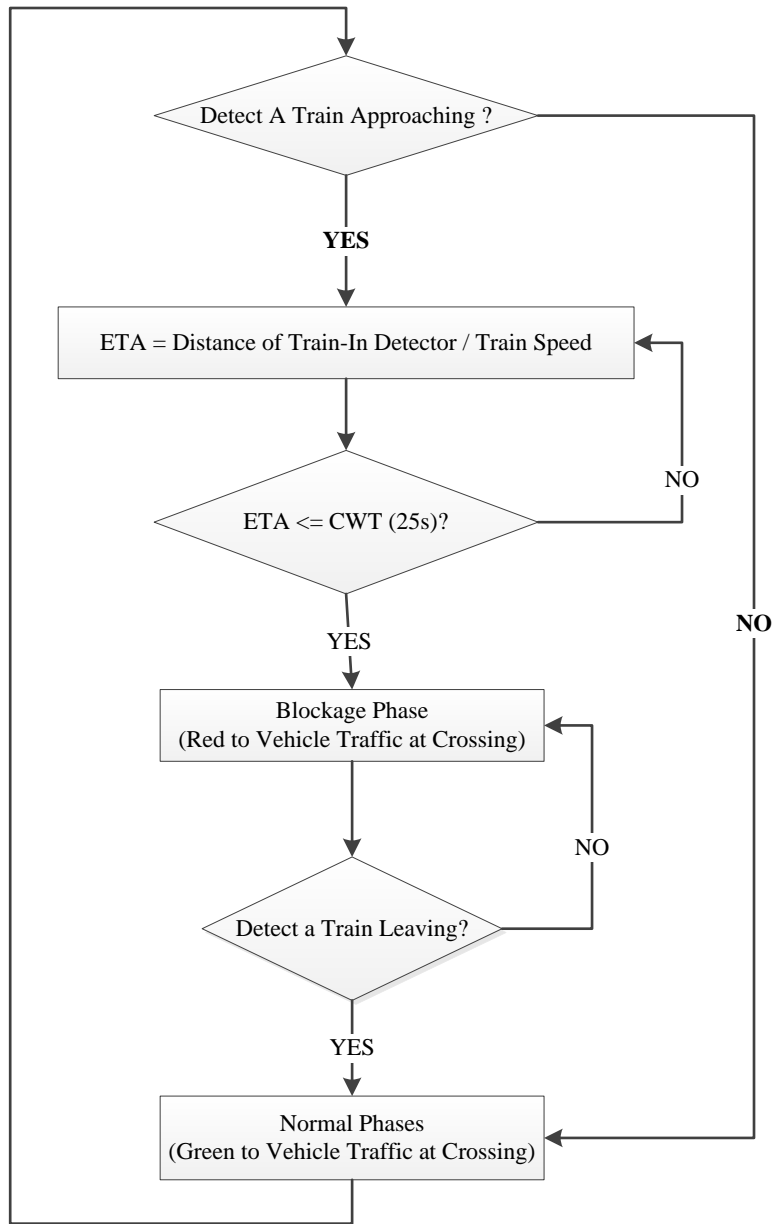
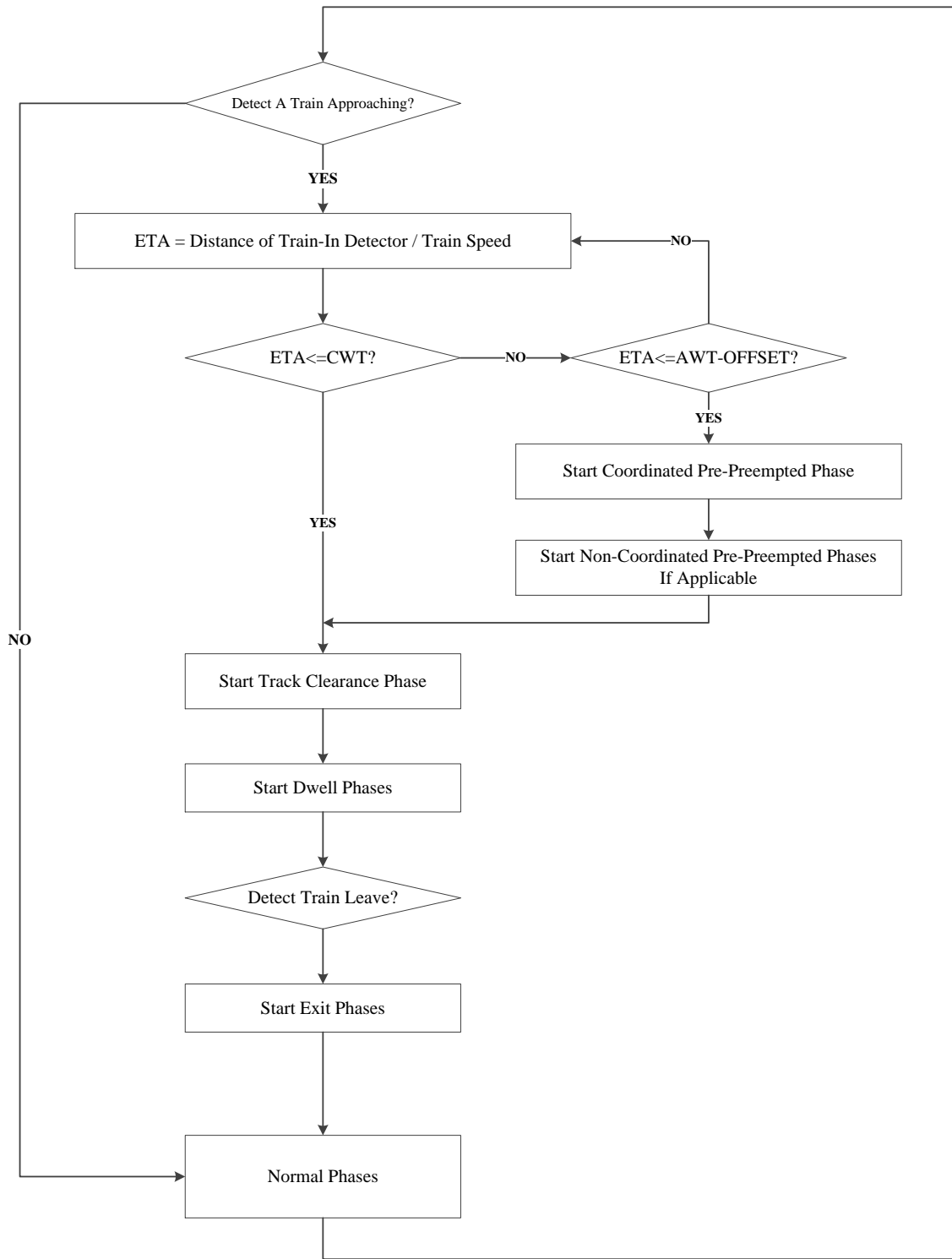

**Figure 6-7 Logic of Crossing Gate Controller in VISSIM**

**Table 6-5 Traffic Controllers Coded in VISSIM**

	<b>Intersection Next to a Crossing</b>	<b>Intersection Near but Not Next to a Crossing</b>
Normal	x	x
Preempted	x	N/A
Pre-preempted	x	x*

\* Coordinated pre-preemption phase only



**Figure 6-8 Pre-preemption Logic for Preempted Intersection Coded in VISSIM**

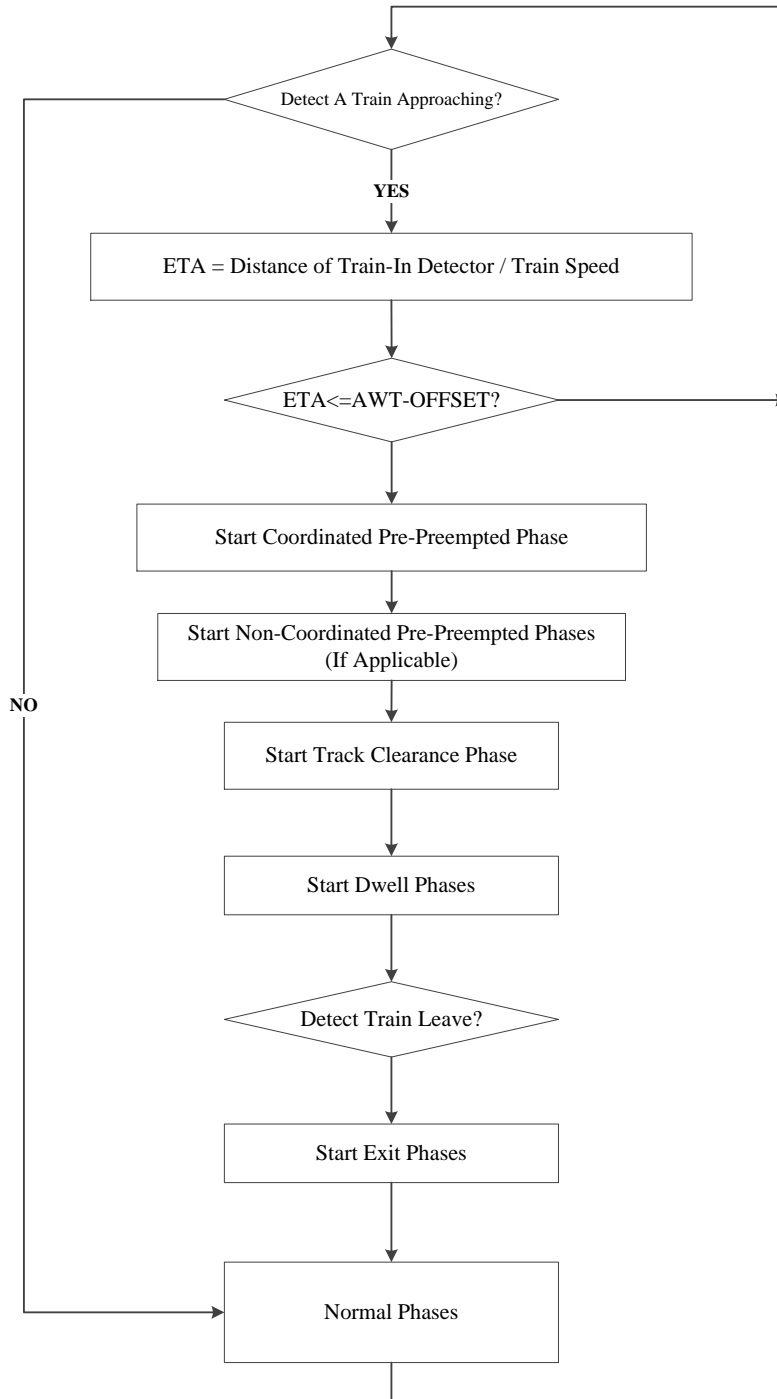

**Figure 6-9 Pre-preemption Logic for Non-Preempted Intersection Next to a Crossing Coded in VISSIM**

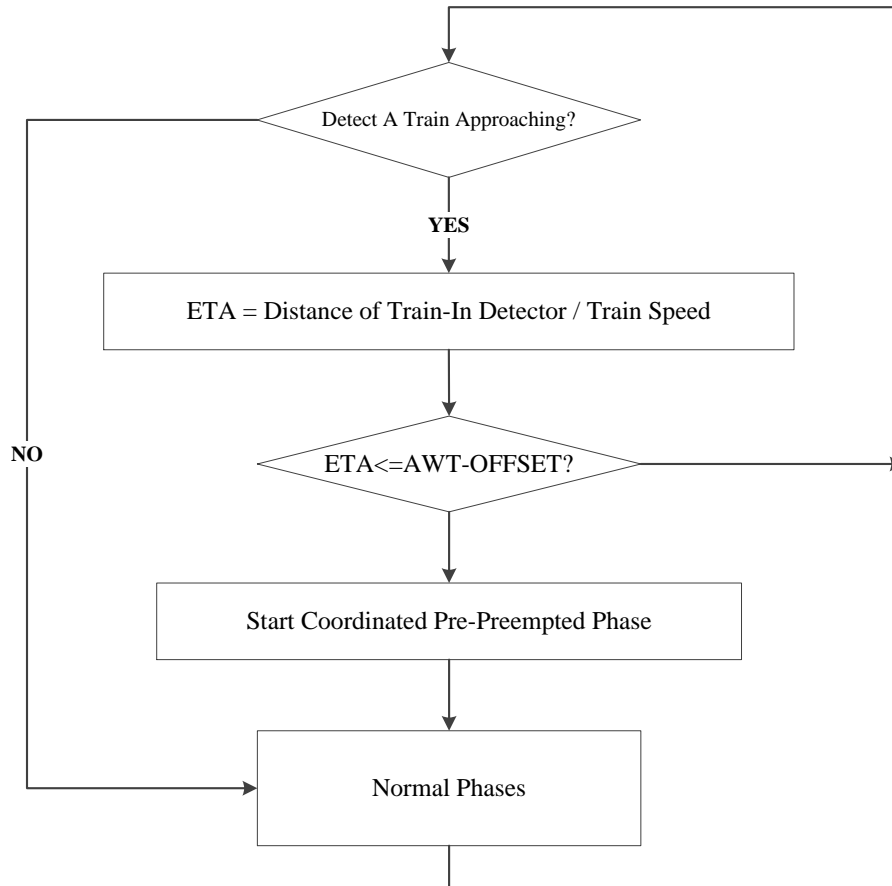

**Figure 6-10 Pre-preemption Logic for Intersection Not Next to a Crossing Coded in VISSIM**

### 6.3.5 Create Scenarios

The following factors were considered in creating simulation scenarios:

- Vehicle Traffic – Vehicle traffic volume along the roadway corridor is the most significant factor, resulting in congestion and long queues on the corridor. Although actual peak-hour volumes at the three control sections were available, this study extended the range of vehicle traffic volumes for assessing the effectiveness of the pre-preemption with different traffic volumes. Based on the collected peak-hour volumes, the corridor volume was changed from 0.1 (V/C ratio) to 0.9 (V/C ratio) at several levels.
- Train Speed – Train blockage duration is another significant factor causing congestion along a roadway corridor. Usually, the duration is decided by train length

---

and train speed. For convenience purposes, this study fixed train length and changed train speed to get various blockage durations.

- Control Strategy – The original traffic control strategy was coded in the simulation models to represent the scenarios before implementing the pre-preemption. Different pre-preemption strategies were coded in the simulation models to test the effectiveness of different pre-preemption logics by comparing to the original logics.

### 6.3.6 Configuring Simulation Parameters

Due to the stochastic nature of traffic flow and driving behaviors, it was necessary to run VISSIM multiple times while varying the random number seeds to gain an accurate reflection of the study corridor performance. To address this issue, multiple VISSIM simulation runs were adopted. In this study, 10 replications were considered and compared for each scenario to reflect different driver behaviors.

In the process of building the study VISSIM networks used in this research, a few simulation parameters were predetermined: traffic regulation (e.g., right-side traffic), period (e.g., 1800 simulation seconds), simulation resolution (5 time steps/Sim.sec), simulation speed and simulation warm-up time, etc. The warm-up time initializes simulation network conditions before beginning the collection of network performance and varies depending on the size of the network and congestion levels. As such, this study used a warm-up time of 900 seconds to give enough time for the network to achieve stable simulation conditions.

### 6.3.7 Measures of Effectiveness

This study evaluated the safety and operational performance of the proposed pre-preemption strategy at the corridor level. Average delay on the roadway corridor was used to evaluate the operational performance of the pre-preemption strategy; average stops along the corridor were used to assess the traffic smoothness, the risk of vehicle-vehicle conflicts, and environmental impacts; and averaged queue length was used to assess the congestion level of the corridor. Table 6-6 lists the MOEs used in this study.



**Table 6-6 Selected MOEs in Simulation**

<b>MOE</b>	<b>Definition</b>	<b>Purpose</b>	<b>Output File</b>
Average Delay	Average delay per vehicle(s) = Total delay time / (active +arrived vehicles) for the whole corridor; delay time of a vehicle is calculated by subtracting quotient of actual distance traveled in this time step and desired speed from length of time step.	Evaluate network-wide mobility (congestion level)	.NPE
Average Number of Stops	Average number of stops per vehicle = Total number of stops/( active + arrived vehicles) for whole corridor; a stop is counted if speed of vehicle was greater than zero at end of previous time step and is zero at end of current time step.	Evaluate mobility in network and risk of vehicle-vehicle conflicts; also related to environmental impacts (fuel consumption and emissions)	.NPE
Average Queue Length	Current queue length measured upstream every time step. From these values, arithmetical average is computed for every time interval; queues are counted from location of queue counter on link or connector upstream to final vehicle in queue condition.	Evaluate congestion level in corridor	.STZ

For each scenario, 10 simulations were conducted, and a series of output files was produced. These output files were read by the codes developed in this study to retrieve MOEs into a project database. Finally, the MOE data were organized into a series of two-dimensional tables. Each table contains the output data of 10 simulations for one MOE over different preemption strategies. These tables were used in before-after data analysis. An example of the table is shown in Table 6-7.

**Table 6-7 Example of a MOE Output Table (Average Delay, seconds per vehicle)**

<b>Simulation Times</b>	<b>Before Pre-preemption</b>	<b>PP_1*</b>	<b>PP_2*</b>	<b>PP_3*</b>	<b>PP_4*</b>	<b>PP_5*</b>
1	123	81	102	102	102	84
2	121	89	100	101	102	89
3	130	103	118	118	134	101
4	118	86	104	104	101	89
5	150	114	131	131	140	114
6	123	89	107	108	113	89
7	143	110	125	128	129	113
8	130	106	120	120	121	106
9	145	109	129	129	127	109
10	130	97	111	111	118	97

\* PP\_x – Pre-preemption Strategy X

---

### 6.3.8 Before-After Analysis

To assess the effectiveness of the pre-preemption strategy under prevailing conditions, a series of comparisons between the scenarios before implementing pre-preemptions and those after implementing pre-preemptions were conducted on each MOE. At the same time, these comparisons were also conducted between different pre-preemption strategies to select a proper strategy with the best performance. The average values of a MOE were compared between original control strategies and different pre-preemption strategies. The following equation was used to calculate the average MOE value:

$$E(\text{MOE}) = \frac{\sum_{i=1}^N \text{MOE}_i}{N} \quad (6-1)$$

where  $E(\text{MOE})$  is the average value of a given MOE;  $N$  is the number of simulation times ( $N=10$  in this study).

---

## 7 SIMULATION RESULTS AND DISCUSSIONS

This chapter describes simulation scenarios, simulation results, and discussions for the three control sections. The coordinated pre-preemption strategies were tested in Sections I and II. As a comparison, ITPS strategy was also tested in the two sections. In Section III, an improved ITPS strategy was tested and compared to ITPS strategy and EWS strategy.

### 7.1 Section I

#### 7.1.1 Site Description and Scenarios

As shown in Figure 6-1, Section I contains six railroad crossings along the FEC railroad corridor and 18 signalized intersections adjacent to the crossings along six roadway corridors. The roadway corridor of W Broward Blvd with four signalized intersections was selected to test the pre-preemption strategy individually (without pre-preemption). The geometry of the corridor is given in Figure 7-1. The following factors were considered in creating the simulation model of Section I:

- The preemption trigger signal at the intersection of N Flagler Dr @ W Sunrise Blvd was used as the trigger for the pre-preemption operations at the target corridor. The train approaching direction was configured as from Sunrise Blvd (North) to Broward Blvd (South).
- Because only one preempted intersection was available at the upstream (north) of the target crossing along the FEC railroad, the ETA could be calculated based on the preemption logs at two successive intersections. Thus, the train speed was assumed as a constant value between Sunrise Blvd and Broward Blvd. The ETA was calculated as the distance between the two corridors along the FEC railroad divided by the train speed.
- The commuter traffic direction on Broward Blvd is westbound. Thus, the coordination direction of pre-preemption phases is Phase 2 (westbound).
- The original signal plans of the four target intersections have no preemption mode. Thus, their pre-preemption phases contain the coordinated congestion clearance phase (Phase 2-6) only, as shown in Figure 7-2.
- Considering the vehicle storage space between Intersection 2133 and the crossing is short (285 ft), an alternative pre-preemption timing at Intersection 2133 was designed as coordinated congestion clearance phase (Phase 2-5) followed by a track clearance (Phase 6), as shown in Figure 7-3.

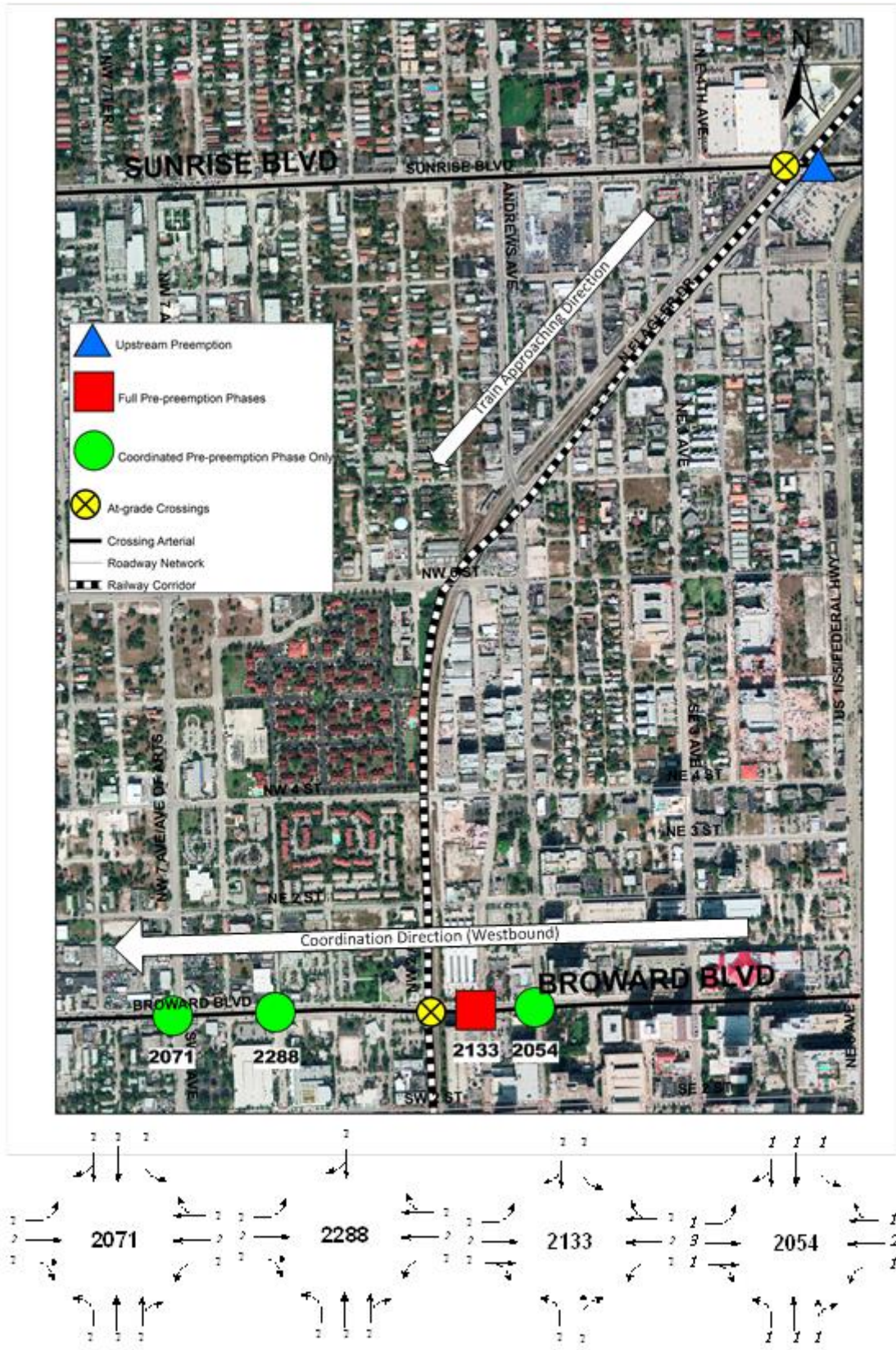

**Figure 7-1 Tested Intersections in Section I**

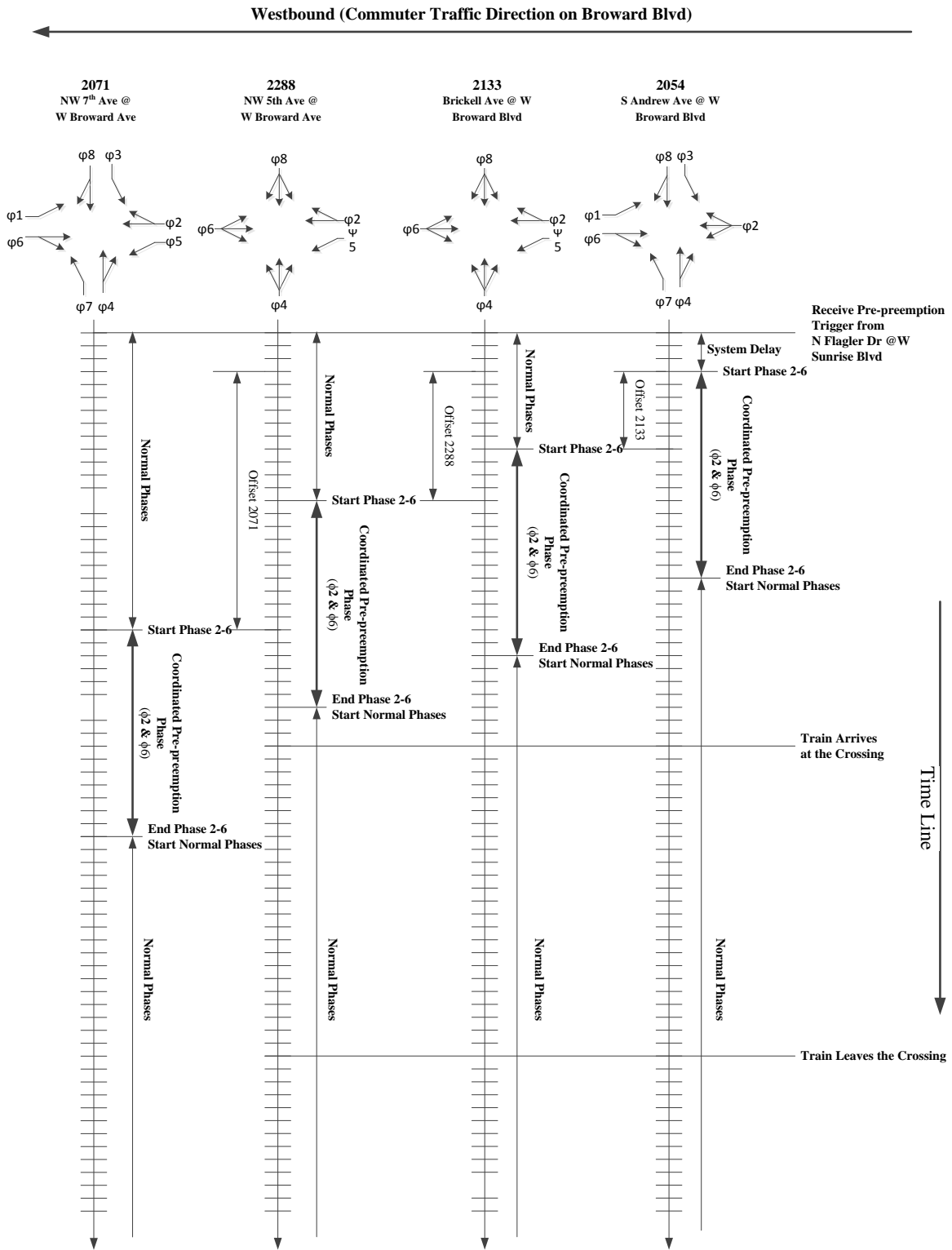

**Figure 7-2 Timeline of Pre-preemption Strategy I (After 1)**

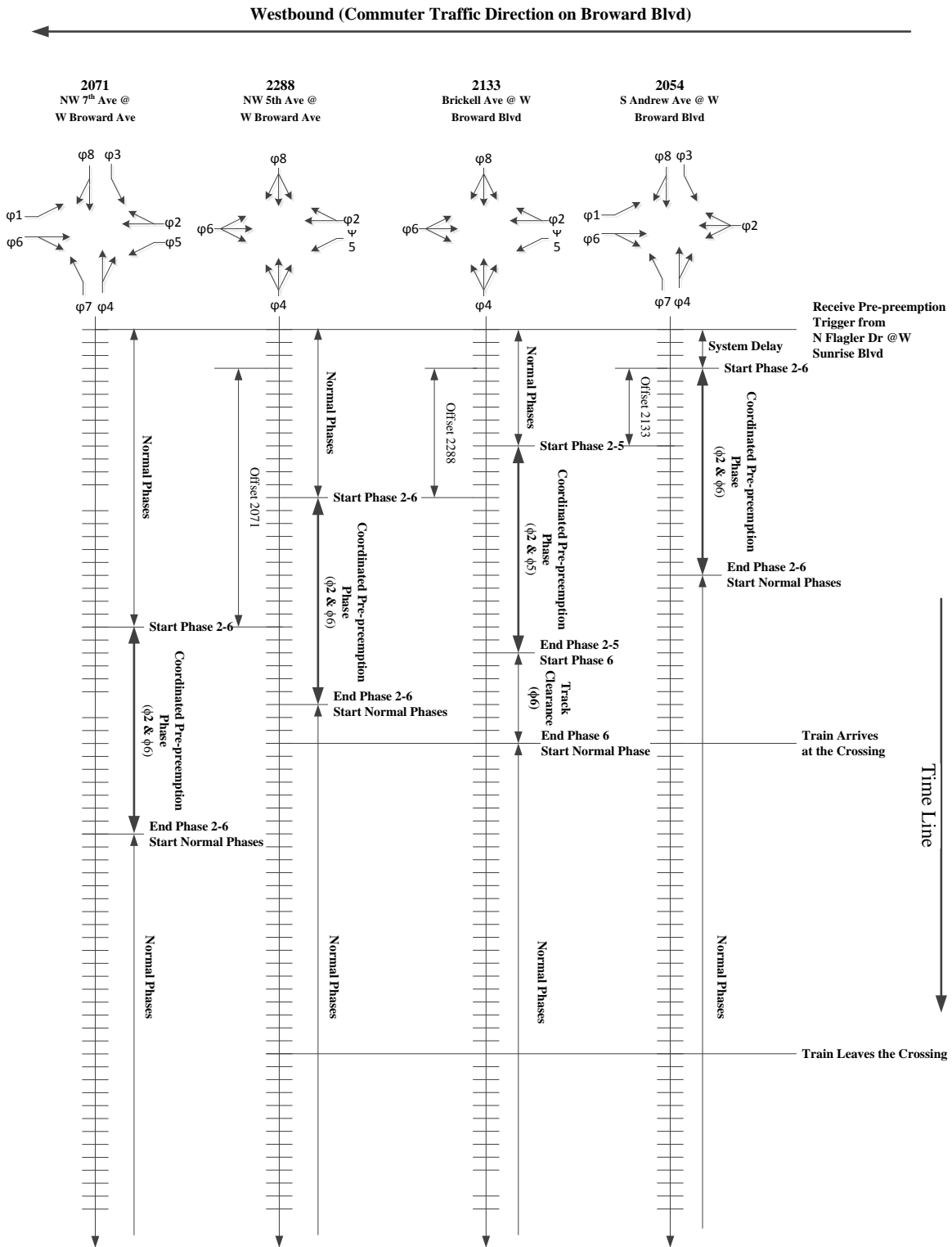

**Figure 7-3 Timeline of Pre-emption Strategy I (After 2)**

- The pre-preemption phase time and offset time were optimized using Transyt-7F for each traffic scenario. The optimization object is to maximize the progressive along the coordination direction (westbound).
- In Section I, 30 scenarios (5 volume levels × 6 train durations) for each pre-preemption strategy (including before pre-preemption) were generated. Five levels of vehicle volume were generated based on different v/c ratios from low to high and six levels of train durations are generated based on train speeds from 10–85 mph. A total of 10 runs were conducted for each scenario. The vehicle volume levels and train duration levels are given in Table 7-1 and Table 7-2, respectively.

**Table 7-1 Vehicle Traffic Volume on W Broward Blvd (Westbound)**

	<b>Level 1</b>	<b>Level 2</b>	<b>Level 3</b>	<b>Level 4</b>	<b>Level 5</b>
<b>v/s</b>	0.1	0.15	0.25	0.3	0.35
<b>volume</b>	403	605	1009	1210	1412
<b>volume/lane</b>	202	303	505	605	706

**Table 7-2 Levels of Train Duration (Train Speed) on W Broward**

<b>Scenarios</b>	<b>Train Speed (mph)</b>	<b>Duration (Sec)</b>
1	10	273
2	25	109
3	40	68
4	55	50
5	70	39
6	85	32

- The pre-preemption strategies were evaluated at network level for Section I, including average delay and average stops along the arterial (W Broward Blvd).

## 7.1.2 Simulation Results

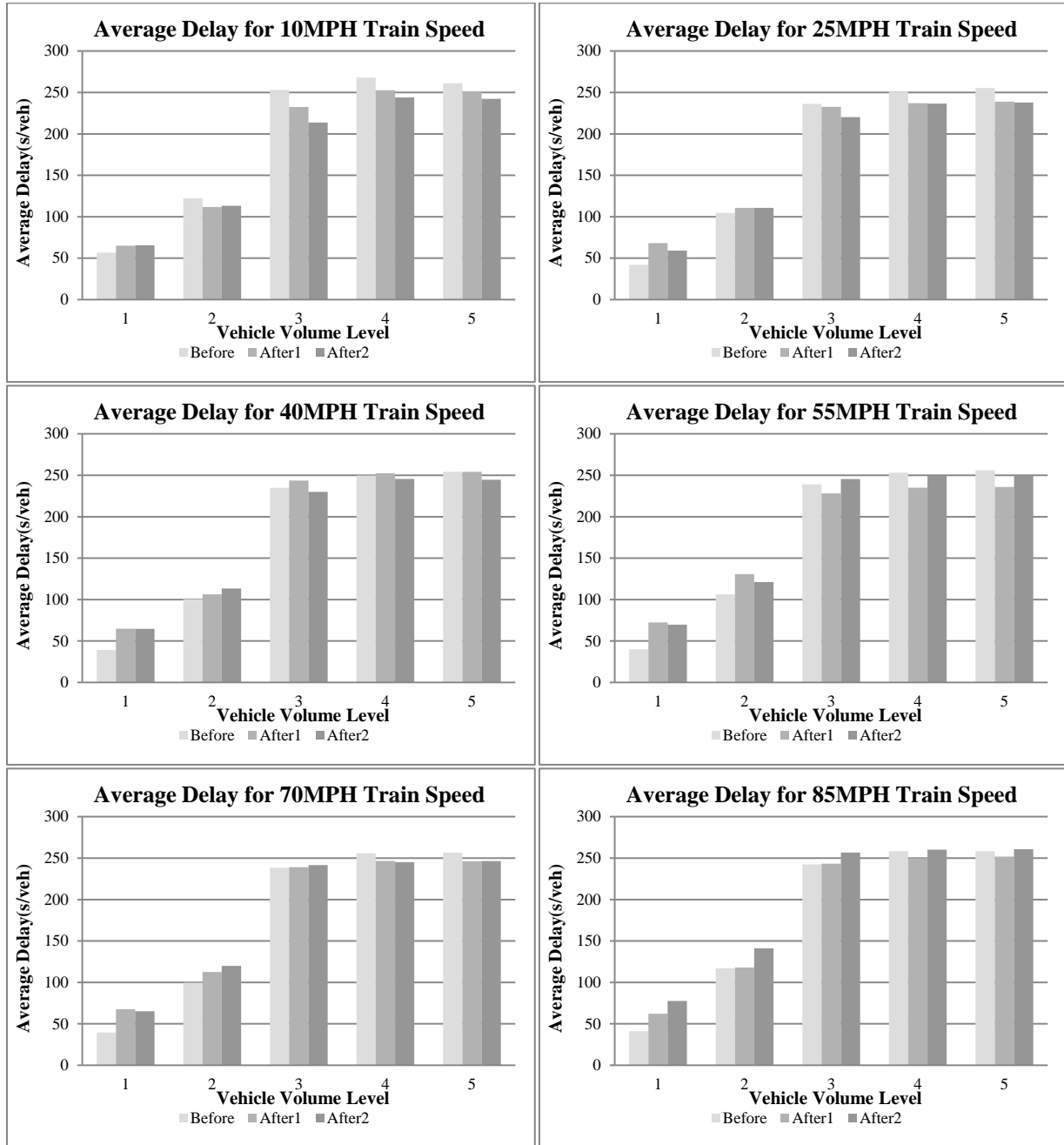

**Figure 7-4 Average Delay in Section I**



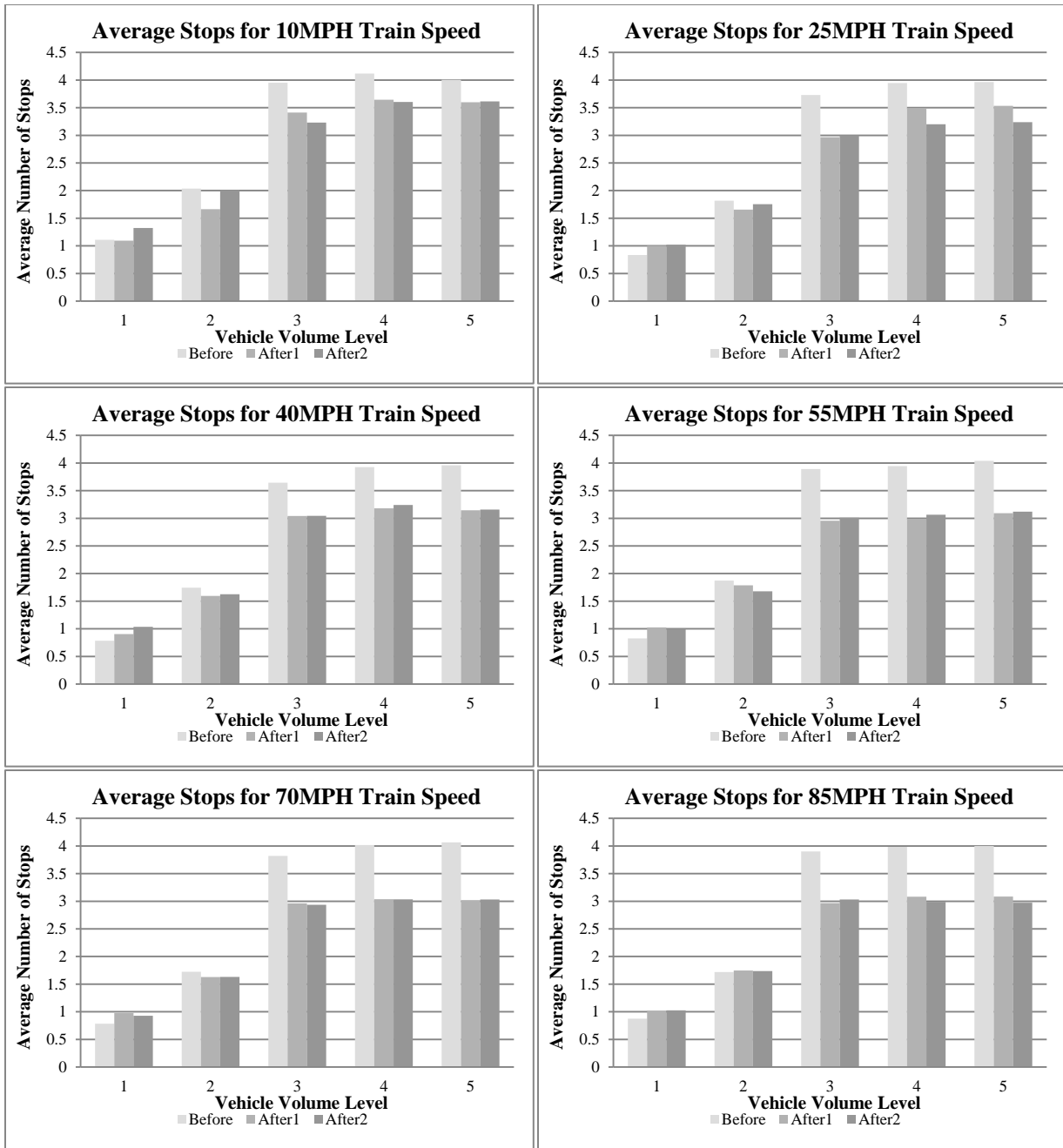
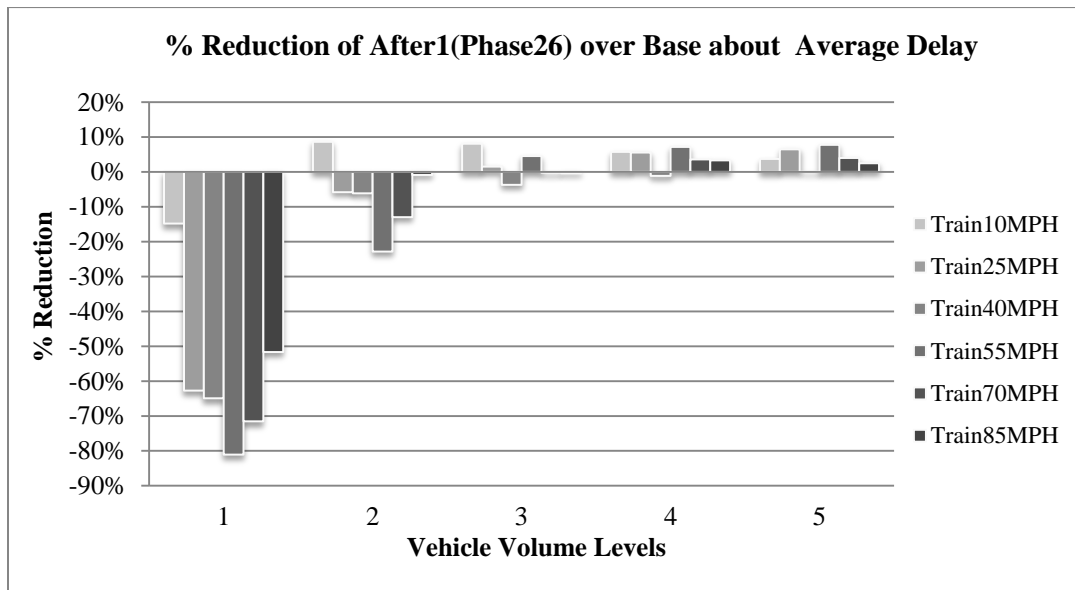

**Figure 7-5 Average Stops in Section I**

---

### 7.1.3 Discussion

Average delay can be used to evaluate the mobility and congestion levels of a roadway network. A smaller value indicates a better operation performance and less congestion of the network. Figure 7-4 shows that the average delay after implementing pre-preemption strategies (After 1 or After 2) is less than that before implementing the strategies with high traffic volumes (volume level  $\geq 3$ ) and long train duration ( $\geq 100$  sec). Under a low traffic volume (volume level  $< 3$ ), the pre-preemption may result in a negative impact. If traffic volume is high and blockage duration is low, the impact of pre-preemption on network average delay is positive but reduction after pre-preemption is small. Figure 7-6 shows the percentage of average delay reduction after implementing the pre-preemption strategy (After 1). With high traffic volume and long duration, the pre-preemption strategy (After 1) may reduce average delay at network level by 4–8 percent.



**Figure 7-6 Average Delay Reduction after Implementing Pre-preemption (After 1)**

Average stops in a roadway network are an indicator of traffic smoothness. Fewer stops represent more smooth traffic operations and lower risks of collisions. Figure 7-5 indicates that pre-preemption strategies can significantly reduce the average stops under high traffic volume for either long or short blockage durations. The reduction percentage by implementing the pre-preemption strategy (After 1) is around 10–25 percent with high traffic volumes, as shown in Figure 7-7.

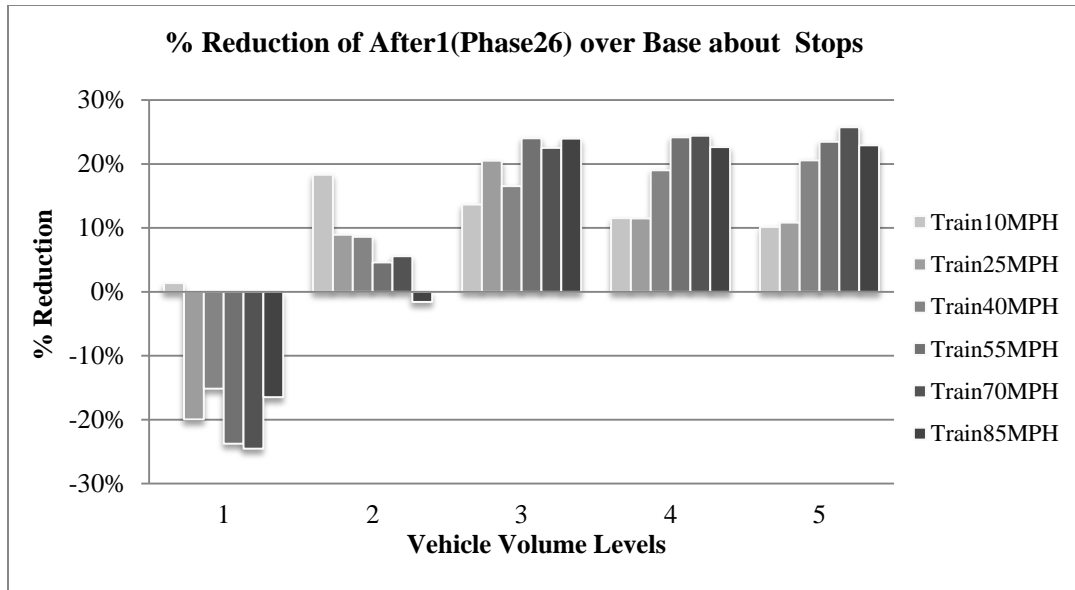

**Figure 7-7 Average Stops Reduction after Implementing Pre-preemption Strategy (After 1)**

## 7.2 Section II

### 7.2.1 Site Description and Scenarios

Section II contains two railroad crossings along the FEC railroad corridor and four signalized intersections near the crossings along roadway corridors. In this study, Section II was used to test the pre-preemption strategy integrating preemption operations. The roadway corridor of Oakland Park Blvd with two signalized intersections (preemption available at N Dixie Hwy at E Oakland Park Blvd) was selected as the simulation objective, as shown in Figure 7-8. The following factors were considered in creating the simulation model of Section II:

- Because no upstream preemption is available for triggering the pre-preemption at the target crossing in Section II, roadside train detectors were assumed to be installed on the upstream (both north and south). The detectors could provide enough advance warning time for the pre-preemption operations at the target crossing.
- The train speed was assumed to be a constant value between the roadway detectors and the target crossing. The ETA was calculated as the distance of detectors from the target crossing along the FEC railroad divided by train speed.

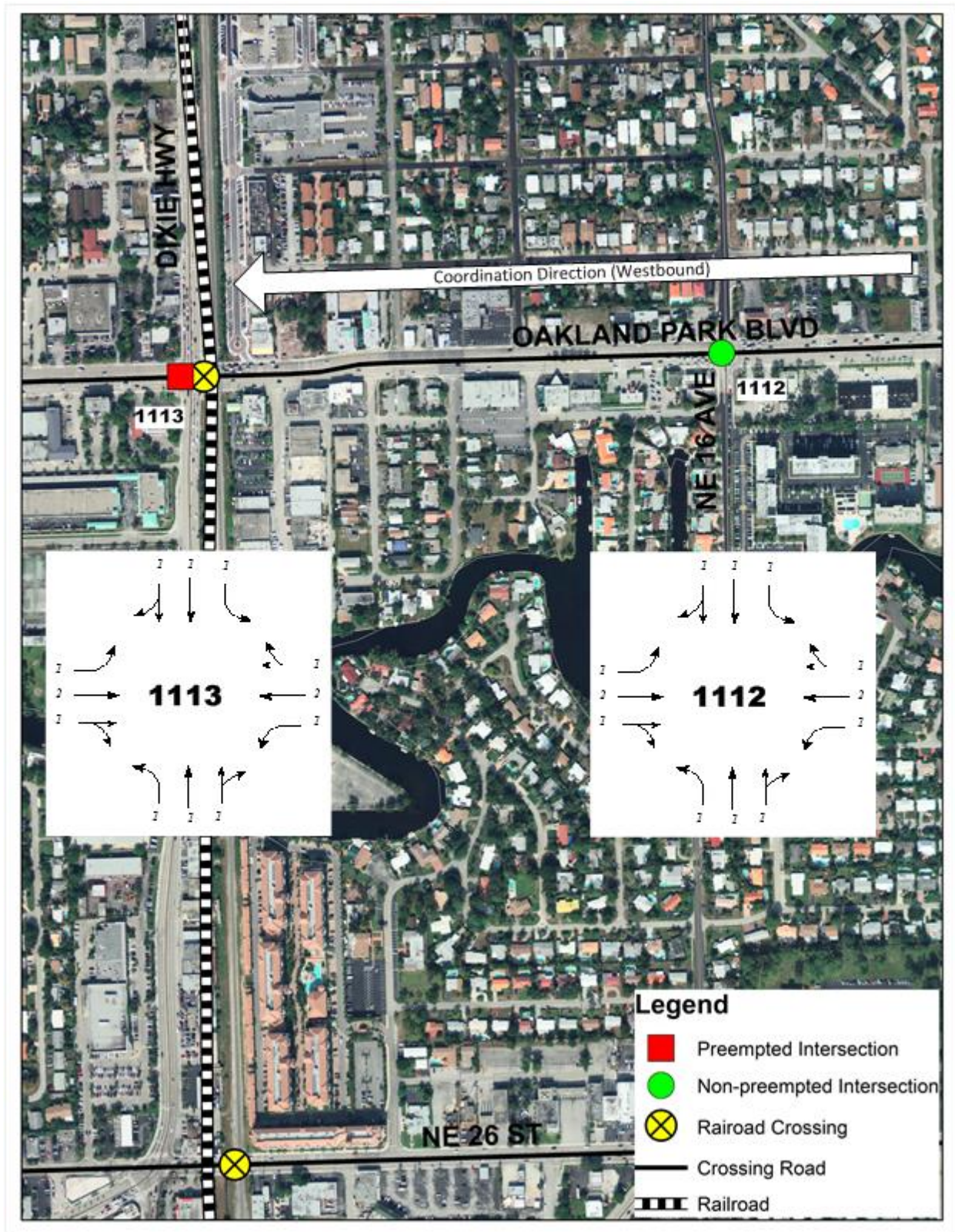

**Figure 7-8 Layout of Tested Intersections in Section II**

- 
- The commuter traffic direction on Oakland Park Blvd is westbound. Thus, the coordination direction of pre-preemption phases is Phase 2 (westbound). The non-preempted intersection (NE 16th Ave at E Oakland Park Blvd) is located upstream from the preempted intersection (N Dixie Hwy at E Oakland Park Blvd) along the coordination direction on the roadway corridor.
  - The non-preempted intersection (NE 16th Ave at E Oakland Park Blvd) has only a coordinated pre-preemption phase (Phase 2-6) for clearing through traffic along Oakland Park Blvd before train's arrival.
  - The preempted intersection (N Dixie Hwy at E Oakland Park Blvd) activates the pre-preemption operation following its upstream intersection (NE 16th Ave at E Oakland Park Blvd) after a given offset. The pre-preemption is terminated by its preemption trigger.
  - Several pre-preemption strategies at the preempted intersection (N Dixie Hwy at E Oakland Park Blvd) were tested:
    - After 1: This strategy has only the coordination phase (Phase 2-6), as shown in Figure 7-9.
    - After 2: This strategy provides "extra" green time for the left-turn movements on the major road (Phase 1-5) before starting the coordination phase (Phase 2-6), as shown in Figure 7-10.
    - After 3: This strategy set the coordination phase as Phase 2-5 and provides a non-coordinated pre-preemption phase (Phase 1-6) before the coordination phase. The purpose of this strategy is to clear left-turning and through movements along the roadway corridor. The timeline is given in Figure 7-11.
    - After 4: This strategy gives "extra" green time to all the movements blocked by train passing the crossing before train's arrival. The coordination phase is Phase 2-5, as shown in Figure 7-12.
  - The ITPS-based strategy was also tested in Section II as a comparison. The ITPS strategy is a fully-actuated phase set implemented at the pre-preempted intersection (N Dixie Hwy at E Oakland Park Blvd) only. No coordination phase was considered in the ITPS strategy. (See Figure 2-4 for the ITPS flow chart.)

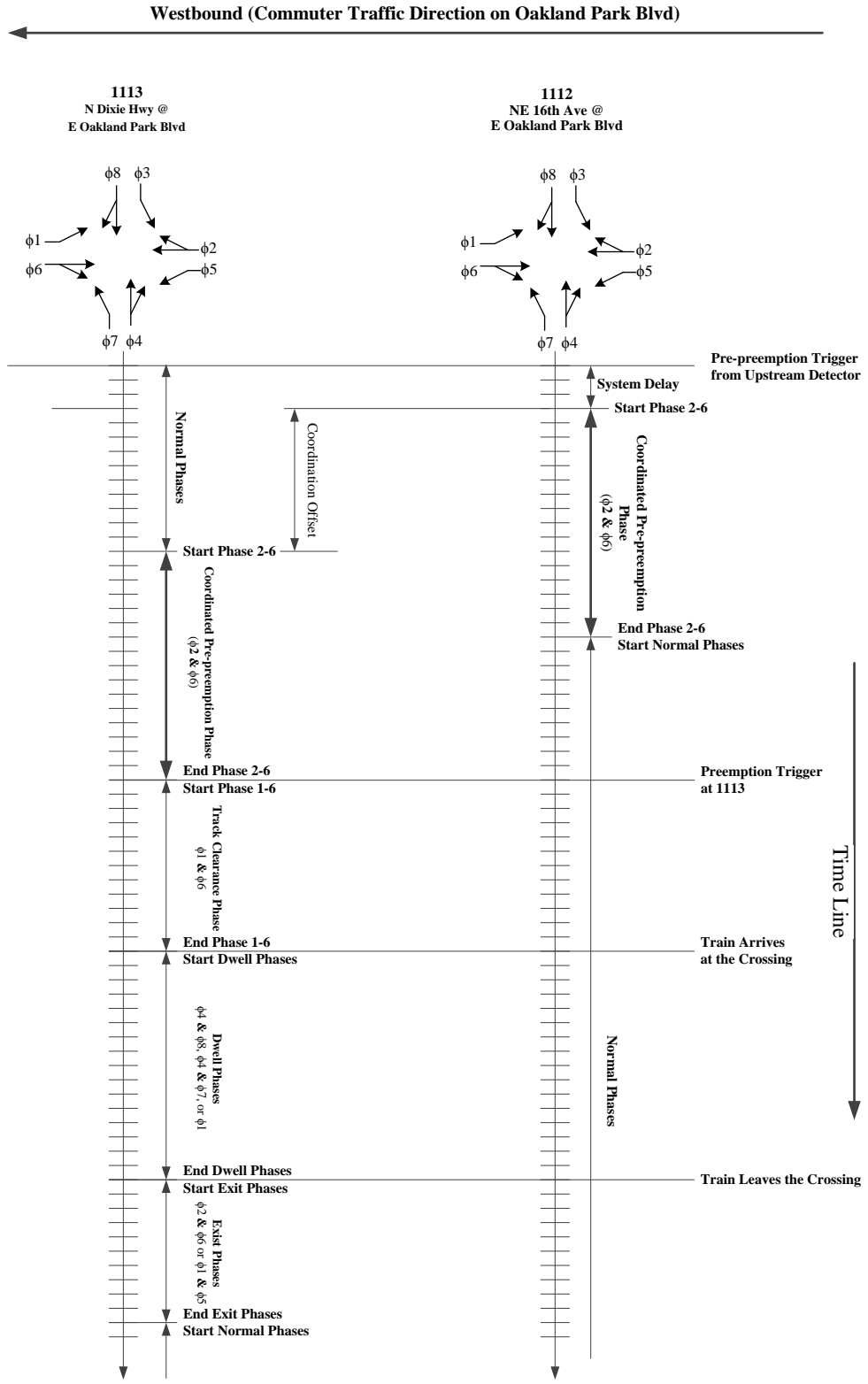

**Figure 7-9 Pre-preemption Strategy - After 1**

Westbound (Commuter Traffic Direction on Oakland Park Blvd)

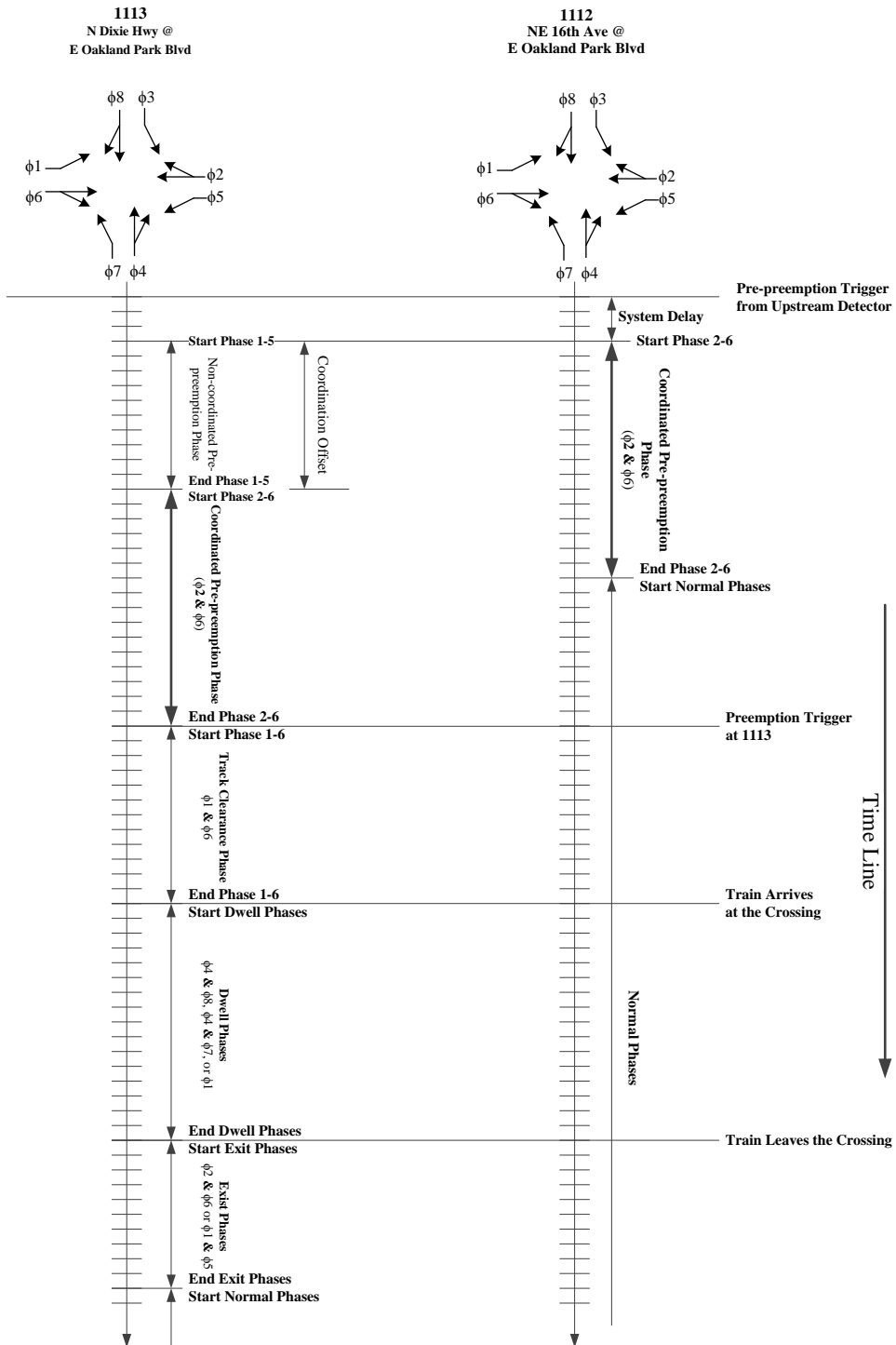
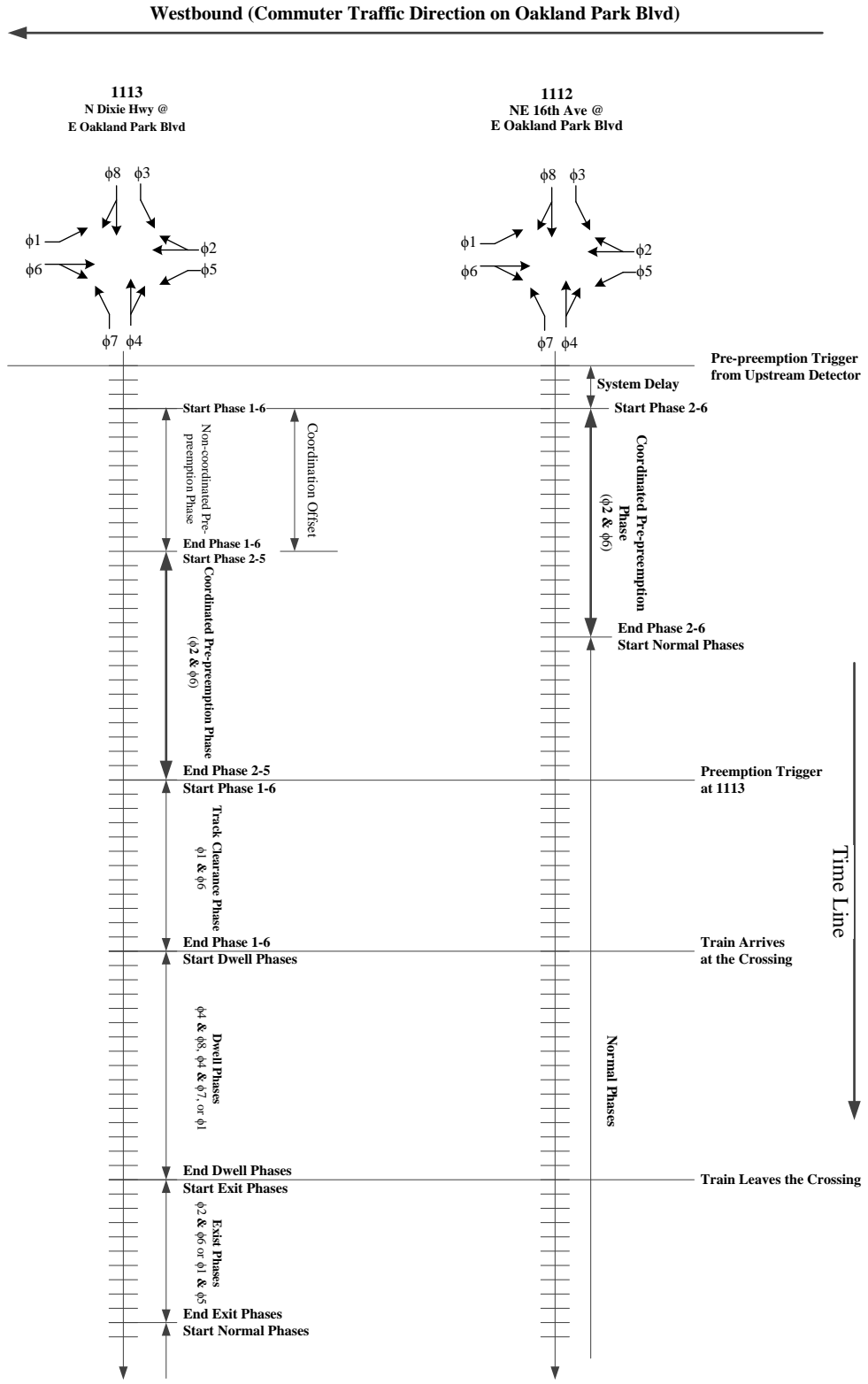
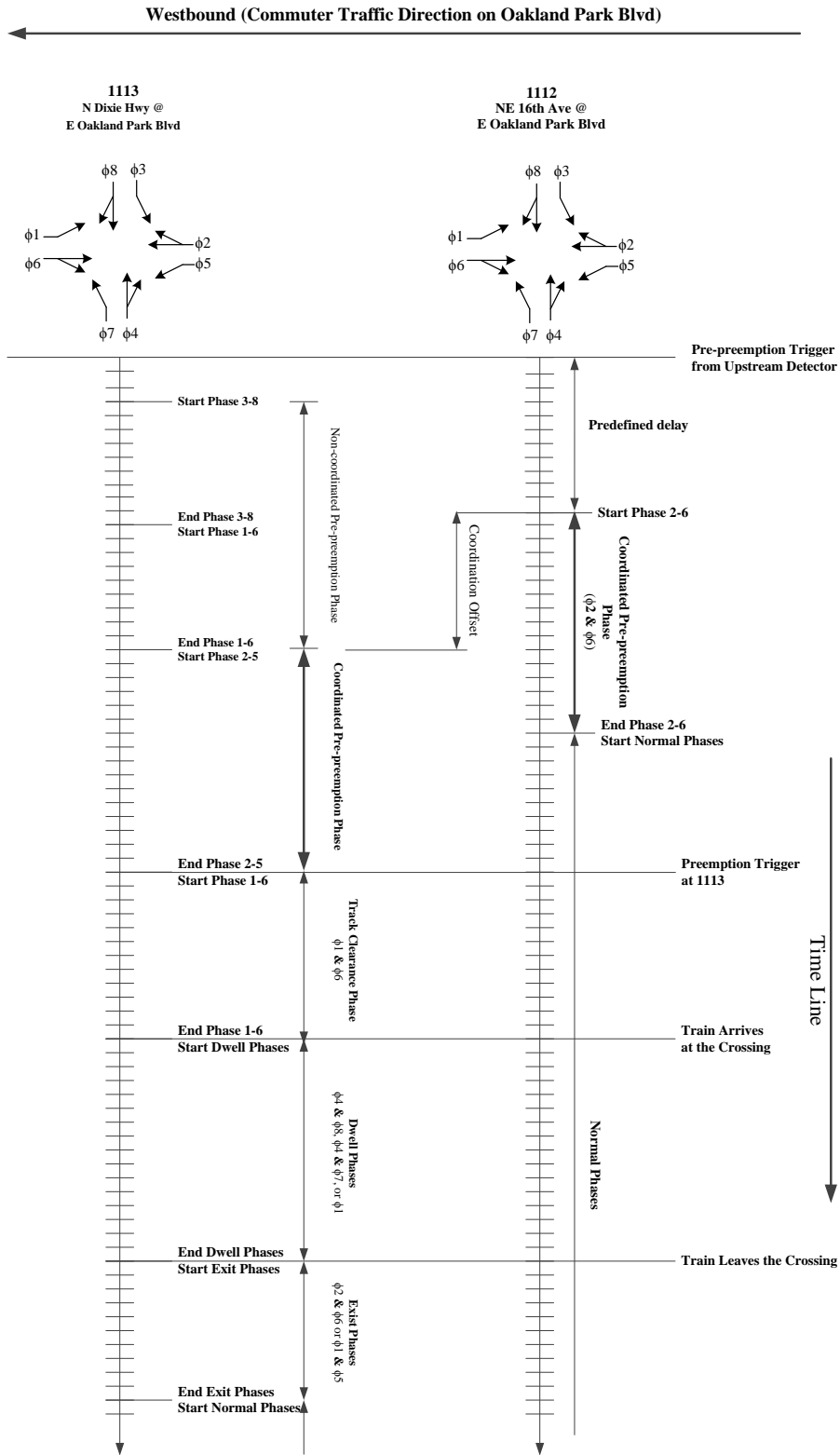

Figure 7-10 Pre-preemption Strategy - After 2



**Figure 7-11 Pre-preemption Strategy - After 3**





**Figure 7-12 Pre-preemption Strategy - After 4**

- The coordinated pre-preemption phase time and offset time were calculated using Transyt-7F for each traffic scenario. The optimization objective is to maximize the progressive along the coordination direction (westbound).
- In Section II, 60 scenarios (10 volume levels × 6 train durations) for each pre-preemption strategy were generated. A total of 10 levels of vehicle volume along the commuter direction on Oakland Park Blvd were generated based on different v/c ratios from low to high, and 6 levels of train durations are generated based on train speeds from 10 mph to 85 mph. A total of 10 runs were conducted for each scenario. The vehicle volume levels and train duration levels are shown in Table 7-3 and Table 7-4, respectively.
- MOEs included average delay, average stops, average queue length, and maximum queue length along the roadway corridor (Oakland Park Blvd).

**Table 7-3 Commuter Vehicle Traffic Volume on Oakland Park Blvd**

<b>Section II</b>	<b>Level 1</b>	<b>Level 2</b>	<b>Level 3</b>	<b>Level 4</b>	<b>Level 5</b>	<b>Level 6</b>	<b>Level 7</b>	<b>Level 8</b>	<b>Level 9</b>	<b>Level 10</b>
v/s	0.05	0.1	0.15	0.2	0.25	0.3	0.35	0.4	0.45	0.5
volume	202	403	605	807	1009	1210	1412	1614	1816	2017
volume/lane	101	202	303	404	505	605	706	807	908	1009

**Table 7-4 Levels of Train Duration (Train Speed) in Section II**

<b>Scenarios</b>	<b>Train Speed (mph)</b>	<b>Duration (s)</b>
1	10	273
2	25	109
3	40	68
4	55	50
5	70	39
6	85	32

## 7.2.2 Simulation Results

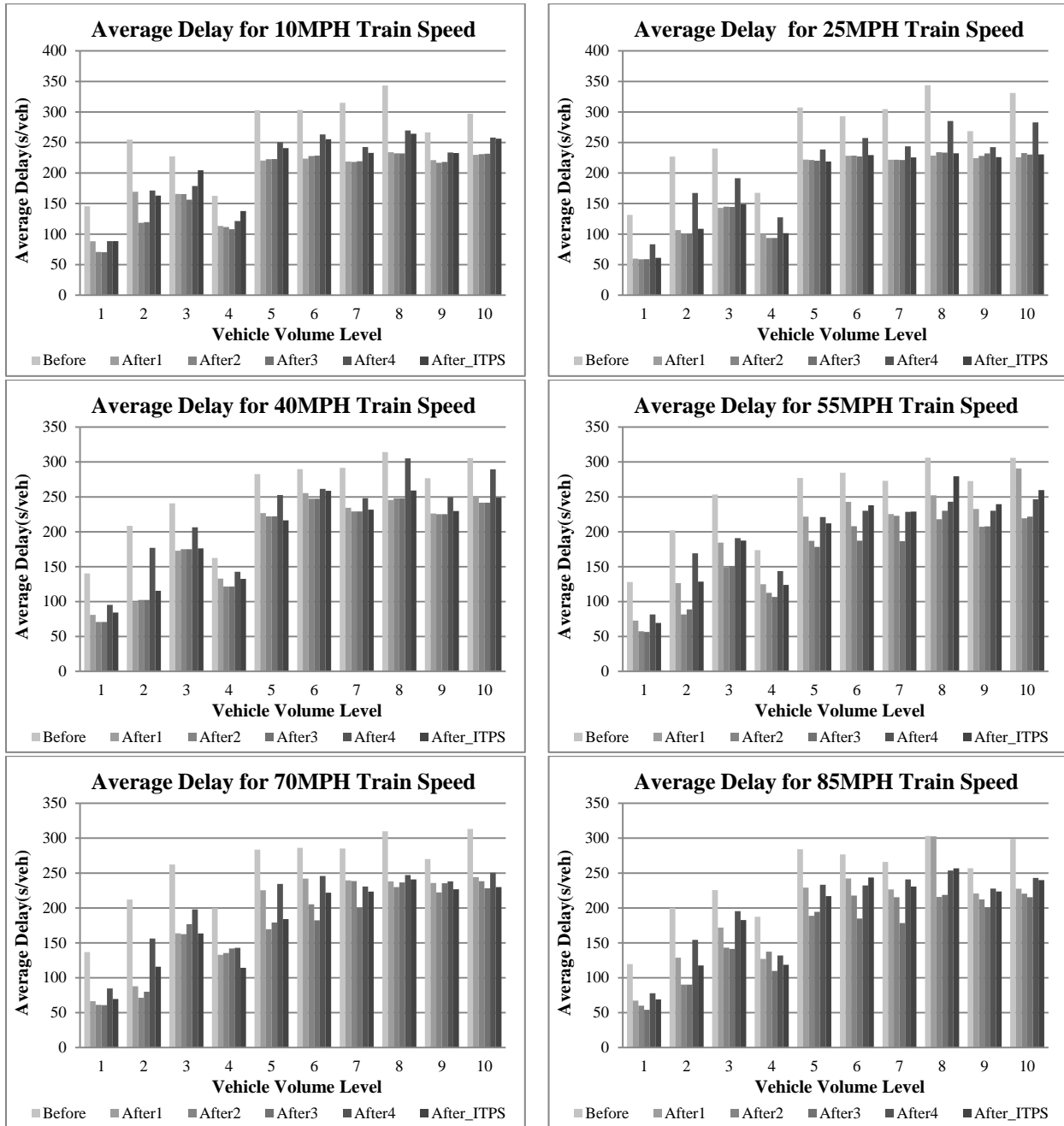
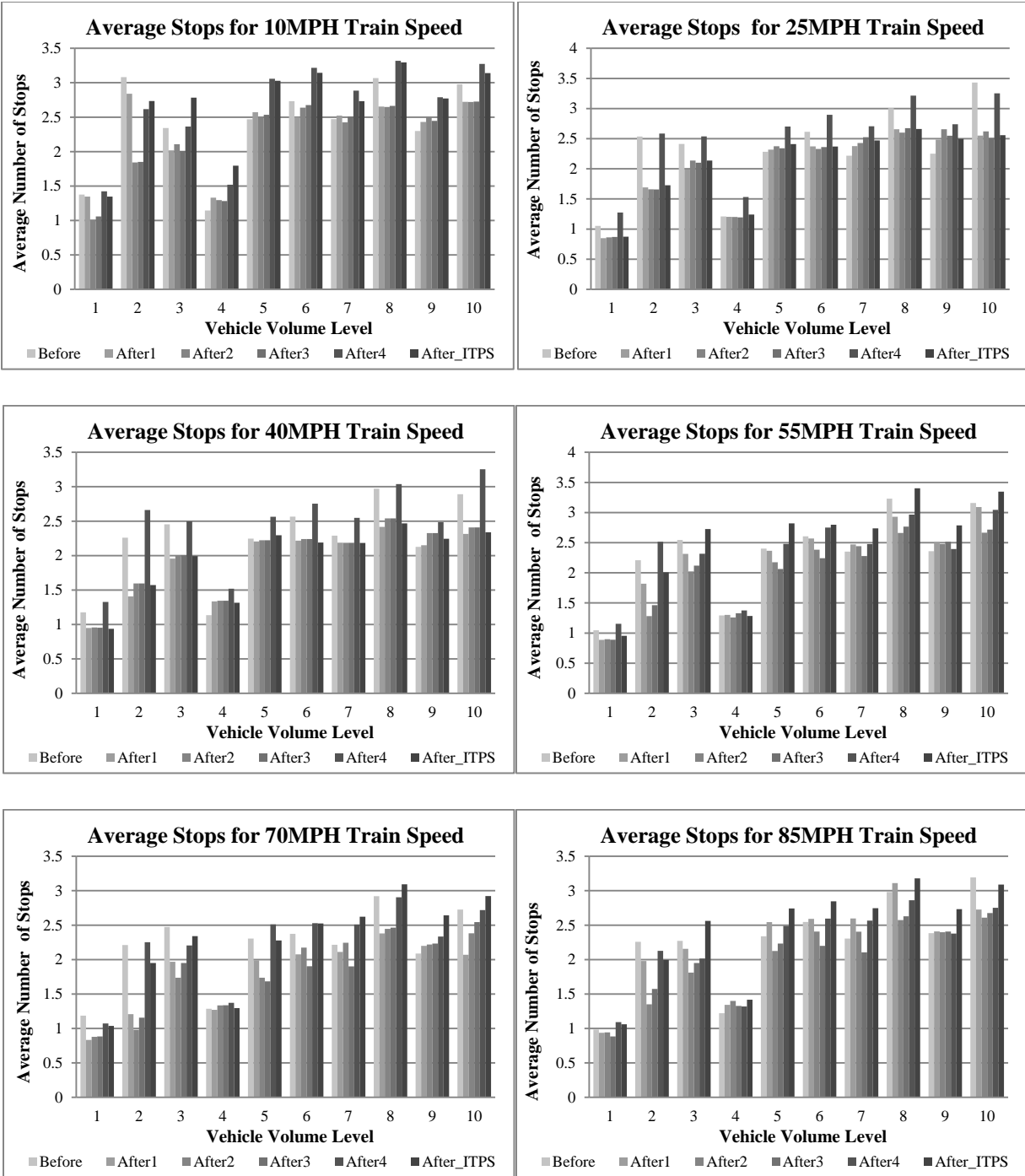
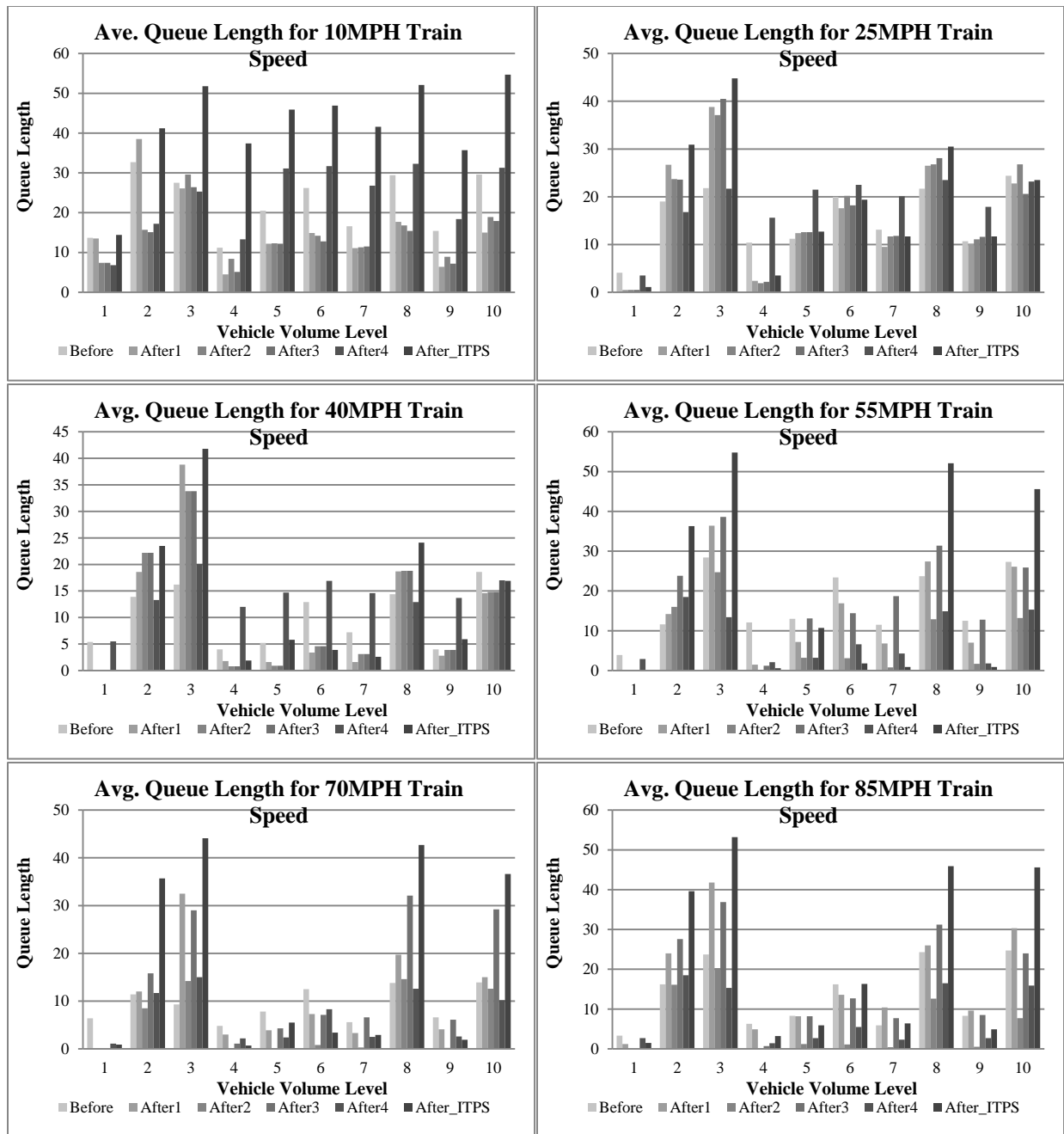

Figure 7-13 Average Delay in Section II



**Figure 7-14 Average Stops in Section II**

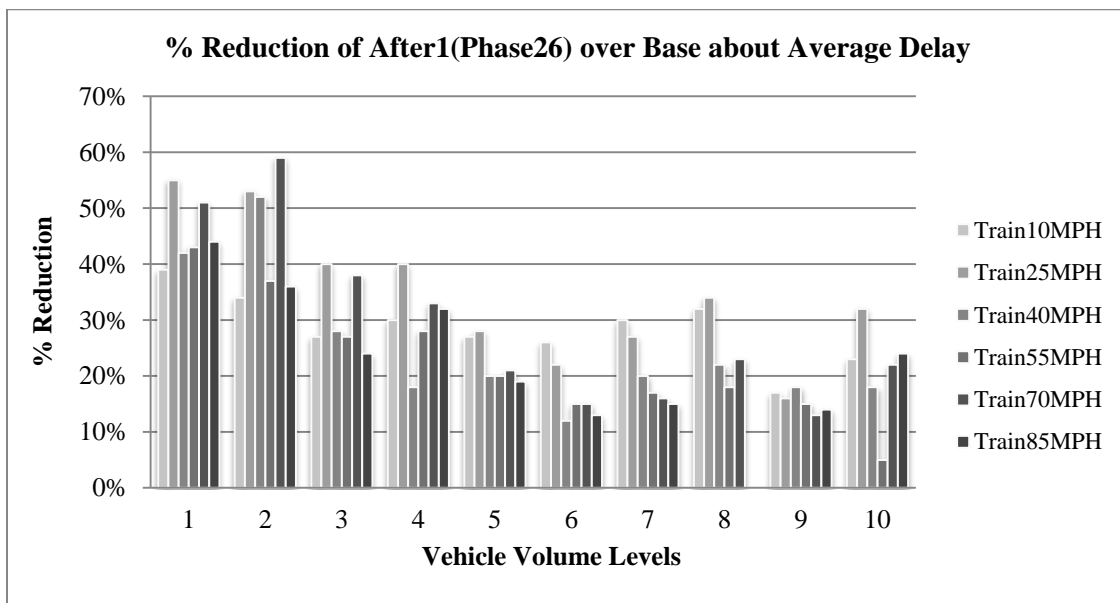

**Figure 7-15 Average Queue Length along Oakland Park Blvd (Westbound)**

---

### 7.2.3 Discussion

The pre-preemption strategies can significantly reduce the average delay on the roadway corridor for each scenario. However, different pre-preemption strategies have different performances. After 4 (three pre-preemption phases) experiences the worst performance compared to other strategies. In most scenarios, the performance of the ITPS-based strategy (After\_ITPS) is lower than three coordinated pre-preemption strategies (After 1, After 2, and After 3). The performance difference among the three coordinated pre-preemption strategies is small. As shown in Figure 7-16, the pre-preemption strategy (After 1) reduces the average delay up to 60 percent.



**Figure 7-16 Average Delay Reduction along Oakland Park Blvd (Westbound)**

In most scenarios, pre-preemption may reduce the average stops. The three-phase pre-preemption strategy (After 4) and the ITPS strategy experience lower performance than other strategies. As shown in Figure 7-17, the pre-preemption strategy (After 1) can reduce the average stops up to 45 percent. The performance is more significant when the traffic volume is lower than Level 3.

The coordinated pre-preemption strategies can reduce average queue length along the roadway corridor in the scenarios of long duration and high volume. However, the performance pattern is complex. Different coordinated strategies have different performance in different scenarios. The ITPS-based strategy, which optimizes traffic operations at individual intersection, tends to increase the average queue length in most scenarios.

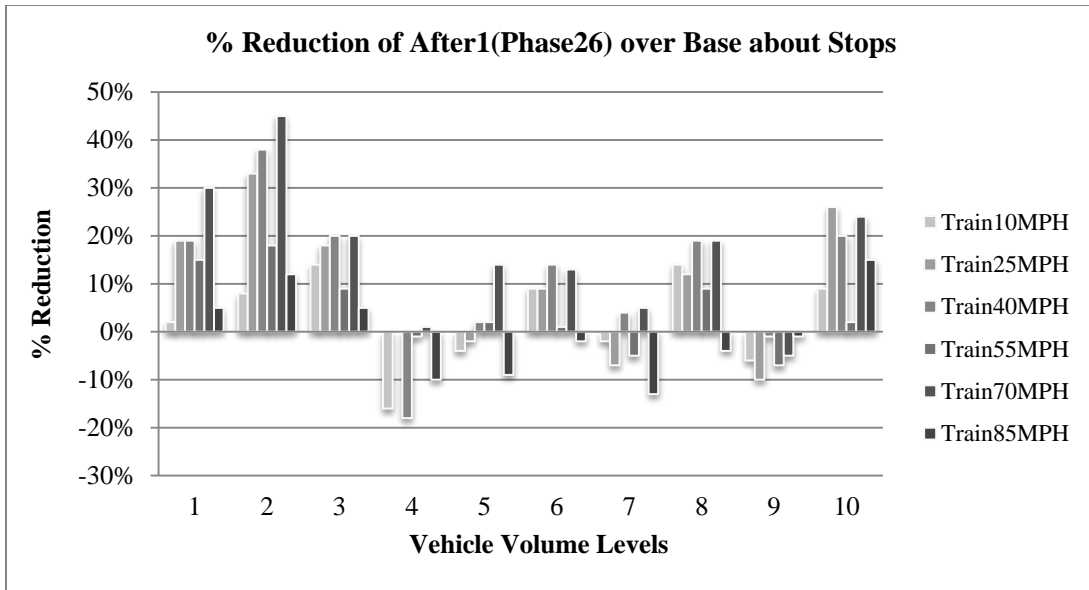

**Figure 7-17 Average Stops Reduction along Oakland Park Blvd (Westbound)**

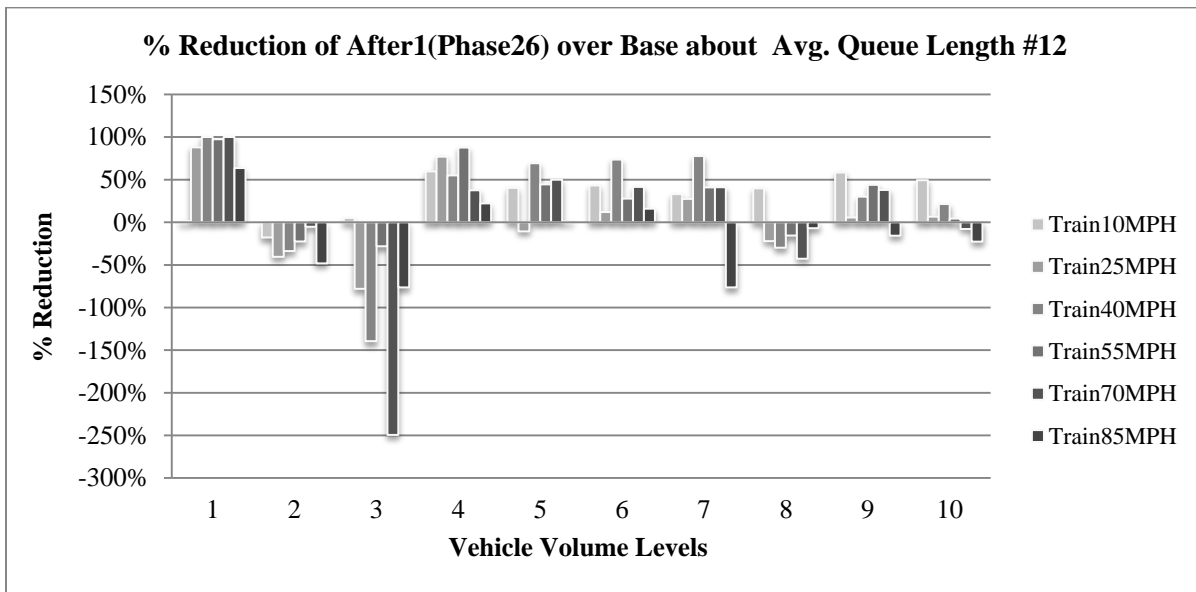

**Figure 7-18 Average Queue Length Reduction along Oakland Park Blvd (Westbound)**

---

## 7.3 Section III

### 7.3.1 Site and Scenarios

In Section III, various ITPS-based pre-preemption strategies were evaluated at the intersection level. Instead of using a simple three- or four-legged intersection in the assessment, as was done in previous studies on the subject (Cho and Rilett, 2007) (Roberts and Brown-Esplain, 2005), a signalized intersection at a six-legged diamond interchange was selected for the testing in this study. As shown in Figure 7-19, the investigated I-95 interchange at W Commercial Blvd has six legs:

- I-95 off-ramp northbound (NB)
- W. Commercial Boulevard westbound (WB)
- I-95 on-ramp northbound (NB)
- I-95 off-ramp southbound (SB)
- W Commercial Blvd eastbound (EB), and
- I-95 on-ramp southbound (SB)

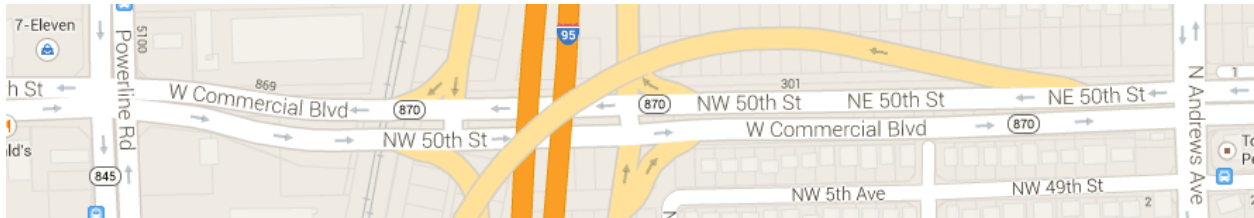

**Figure 7-19 Layout of W. Commercial Boulevard with CSX Rail Corridor**

There are three movements in the segment that is connecting the two ramp terminals underneath I-95: 1) W Commercial Blvd EB through, 2) W Commercial Blvd EB left-turn to I-95 on-ramp NB, and 3) W Commercial Blvd WB through. A north-south railroad corridor (CSX corridor) intersects W Commercial Blvd in Fort Lauderdale. The CSX corridor is used by commuter rail (Tri-Rail), long-distance rail (Amtrak), and a commercial freight rail service. The interchange is approximately 150 feet east of the CSX railroad. A simultaneous preemption is currently implemented at the intersection, which is activated by a CWT system that provides train's arrival signals 28 seconds before train's arrival. As can be seen from Figure 7-20, the target intersection in this project is different from the previous studies; not only are there more legs within the intersection, but also the Track Clearance (TC) phase is different from the normal signal phases.



**Sequence of Operation**  
**Commercial Blvd and I-95 (A-088) Mod 25 and higher**

NORMAL OPERATION		
WEST side	Phase	EAST side
	Phase 1 NB	
	Phase 2 EW	
	Phase 3 EBL	
	Phase 4 EBL CLEAR/SB START	
	Phase 5 SB	
	Phase 6 CLEAR	
	Pre-emption Clear	
	Active in pre-emption (SB)	
	Return after pre-emption (NB)	

  
 NORTH

**Figure 7-20 Phasing Diagram of I-95 Interchange at W. Commercial Boulevard**

The activation of the pre-preemption strategies proposed in this study requires two upstream intersections with preemptions on the train's path. As illustrated in Figure 7-21, the two upstream intersections with implemented preemptions in this study are Powerline Rd at W Prospect Rd, and I-95 at Oakland Park Blvd. These two intersections are located approximately 2,600 feet and 6,100 feet, respectively, to the south of the target intersection (I-95 at W Commercial Blvd). Since there is no station between the I-95/W Commercial Blvd intersection and I-95/Oakland Park Blvd intersection, the trains are not expected to stop in between. This study evaluates pre-preemption strategies at the intersection of I-95 interchange at W Commercial Blvd, based on the NB train deactivations

of the two upstream intersection preemptions. Since the upstream preemption information to the north of the target intersection was not available, no pre-preemption strategy was investigated for the SB trains.

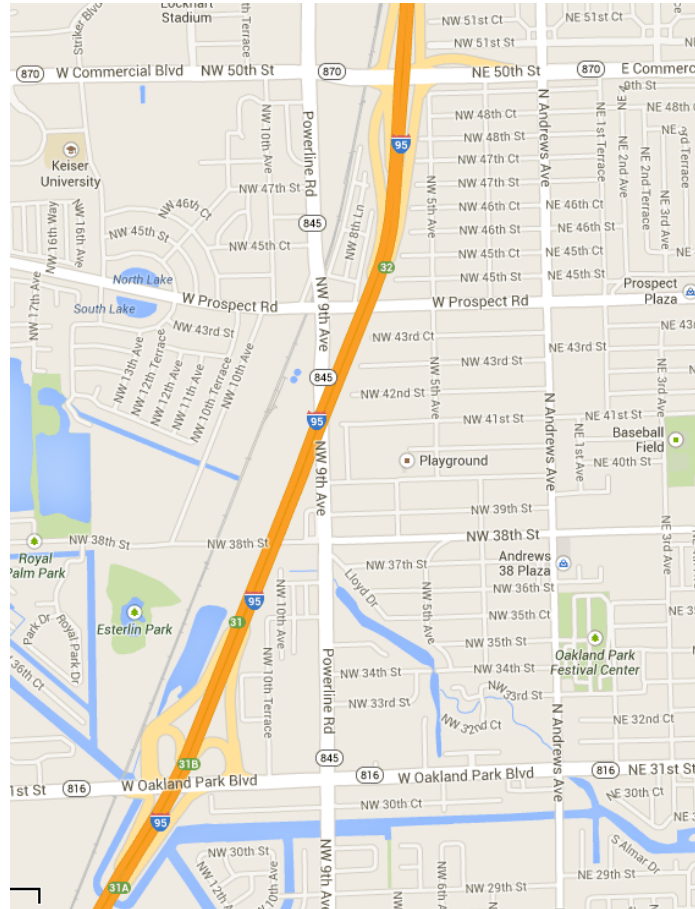
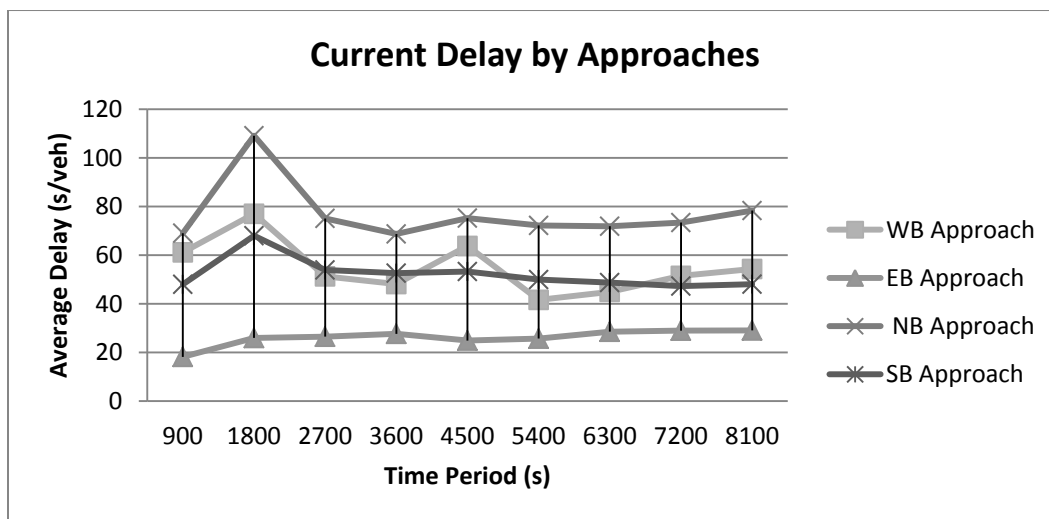

**Figure 7-21 Locations of Two Upstream Intersections along CSX Rail Corridor Relative to Target Intersection**

The study period in this research was the PM peak period, specifically from 4:00–6:00 PM. During this two-hour period, five SB Tri-Rail trains and four NB Tri-Rail trains pass the intersection according to the train schedule, which was confirmed by a recorded video of the train operations. To assess the pre-preemption strategies, the network, including the five intersections highlighted in Figure 7-21, was coded in the VISSIM micro-simulation model (version 5.40-06). Based on a previous report, the average speed of Tri-Rail trains is 38 mph. Thus, the base model simulated all trains at an average speed of 40 mph with the default speed distribution in VISSIM. Turning movement counts at the intersection of Powerline Rd at W Commercial Blvd were collected by Broward County on Tuesday,

December 11, 2012. Turning movement data at the intersection of N. Andrews Ave at W Commercial Blvd were collected by the County on Wednesday, December 12, 2012. The turning movements at the target intersection of I-95 interchange at W Commercial Blvd were videotaped and extracted by the researchers on Thursday, April 18, 2013. Signal Operating Plans (SOPs) were provided by Broward County, as shown in Figure 7-20. During the PM peak hours, the intersections of Powerline Rd at W Commercial Blvd and N. Andrews Ave at W Commercial Blvd operate under coordination. All phases at the target intersection of I-95 interchange at W Commercial Blvd are flagged as Max Recall during the PM peak hours. In other words, the target intersection operates in a fixed-time mode during normal operations in the PM peak.

All signal plans, including actuated control, signal preemption, and pre-preemption strategies, as discussed below, were coded in an add-on signal control module using the VAP facility in VISSIM. The base model with no preemption was calibrated based on observed traffic conditions, including volumes, signal control, and queue lengths at the subject intersection. Figure 7-22 shows the variation of the average delays for different approaches at the target intersection during the PM peak period. This figure can be used in justifying and providing priorities for movements (based on delays) as part of the pre-preemption strategies.



**Figure 7-22 Current Delays by Approaches at Target Intersection**

Three types of pre-preemption strategies were investigated in this paper. These strategies are implemented prior to the normal preemption operation to avoid interference once this operation begins.

---

## **ITPS**

The first investigated strategy applies the same logic as the ITPS introduced by Cho (Cho and Rilett 2007) except that the train's ETA is calculated based on the relationship between the preemption deactivations at two upstream intersections instead of information collected from point infrastructure detectors.

### **Modified ITPS**

The second strategy involves a modification of the ITPS algorithm to provide extra green times to the phases that suffer from higher delays during normal operations, as determined based on historical data, simulation model results, or in accordance with a priority provided by the user. For example, as shown in Figure 7-22, which is based on simulation model results, it seems beneficial to serve Phases 1, then 2, and/or 3, representing the NB, WB, and EB phases, respectively, during the pre-preemption period. Unlike the ITPS, which does not change the pre-defined phase sequence, the Modified ITPS jumps to the desired phase(s) during the pre-preemption based on the established priorities.

The logic algorithms of the Modified ITPS are shown in Figure 7-23, Figure 7-24, and Figure 7-25. As shown in Figure 7-23, if Phase 1 is being served at the time the pre-preemption Strategy is activated, the Modified ITPS transfers the right-of-way to either Phase 2 or Phase 3, according to the calls after either gap-out or max-out of Phase 1. Phase 2 is given higher priority than Phase 3 in this pre-preemption strategy since the WB approach suffers higher delays than the EB approach in the base model. In the case that no call is placed for both Phase 2 and 3, the controller will keep Phase 1 active until the end of the pre-preemption strategy (i.e., the activation of the regular preemption strategy).

Similarly, as can be seen from Figure 7-24, if Phase 2 is the active phase when the pre-preemption strategy is triggered, only Phase 3 will be served if there is a call after either gap-out or max-out of Phase 2. If there is no call from Phase 3, the controller will not terminate Phase 2 until the end of the pre-preemption strategy. Phase 1 will not be served in this case because it has been just served before Phase 2 is being served. It is out of drivers' expectation to serve Phase 1 again immediately after serving Phase 2. As a result, Phase 1 is not given any green time during this pre-preemption strategy though it suffered the highest delays.

In addition, in reference to Figure 7-25, if any one of Phase 3, 4, 5, or 6 is being served at the beginning of the pre-preemption strategy, the controller will safely transfer the right-of-way to either Phase 1 or Phase 2 depending on the calls. Again, Phase 1 is considered prior

to Phase 2 since Phase 1 suffered the highest delay in the base model. If there is no call from both phases, the controller will keep the current phase active until either the pre-preemption strategy is ended or the call from Phase 1 or Phase 2 is received.

Before transferring the right-of-way to the desired phase in any conditions discussed above, the logic algorithms test whether the ETA (i.e., time difference between the now and the activation of the regular preemption strategy) is long enough to serve the yellow + all red time and the minimum green time of the next phase. The phase will be changed only if the above criteria are satisfied. Moreover, Phase 4 and 5 are not considered to be served by the Modified ITPS during pre-preemption because the I-95 SB Off-Ramp will be served during the dwell phase. Phase 6 is not served by the pre-preemption strategy because its movements are also served in Phase 2.

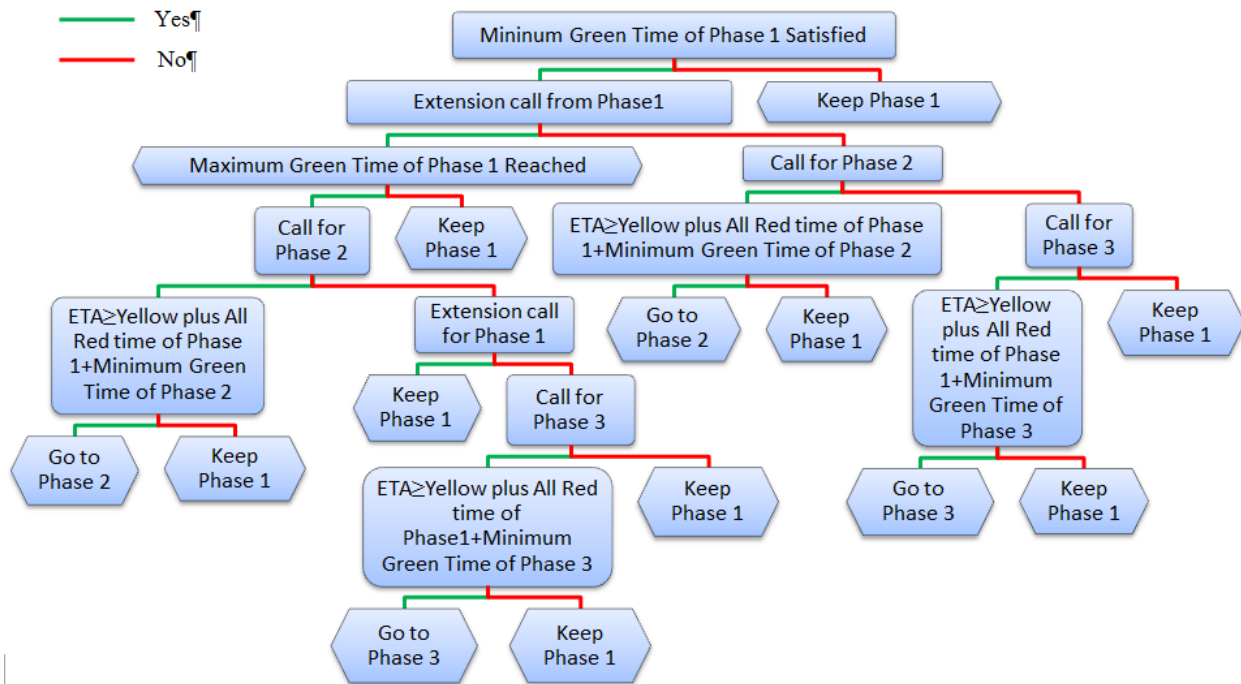

**Figure 7-23 Logic Algorithm of Modified ITPS Pre-Preemption Strategy When Current Phase Is Phase 1**

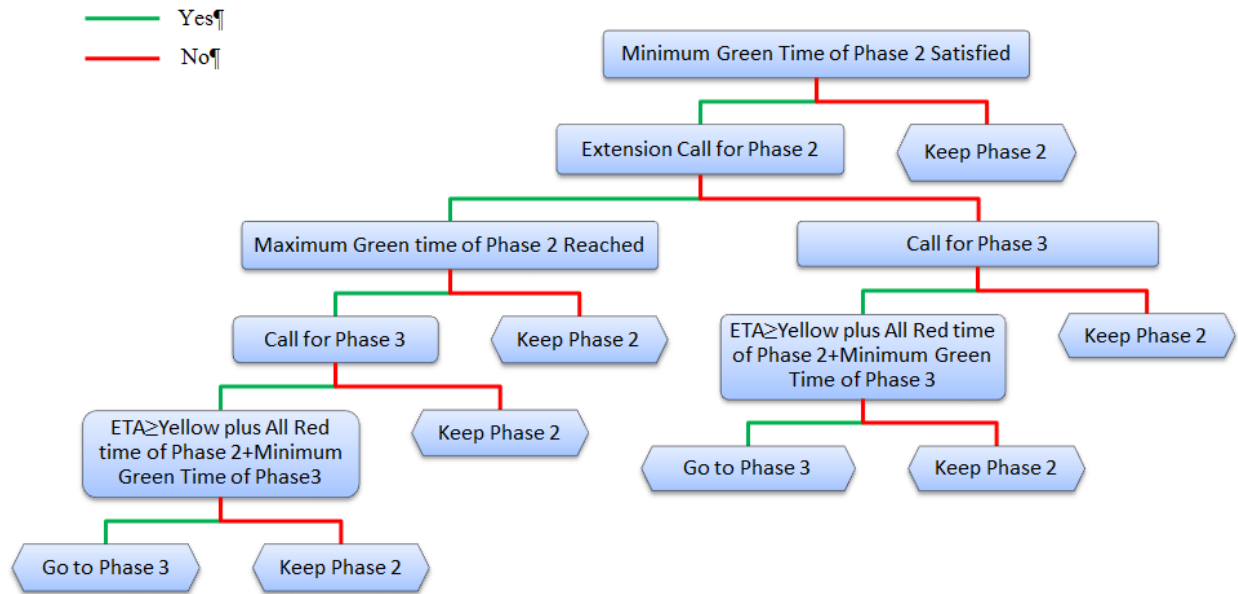

**Figure 7-24 Logic Algorithm of Modified ITPS Pre-Preemption Strategy When Current Phase Is Phase 12**

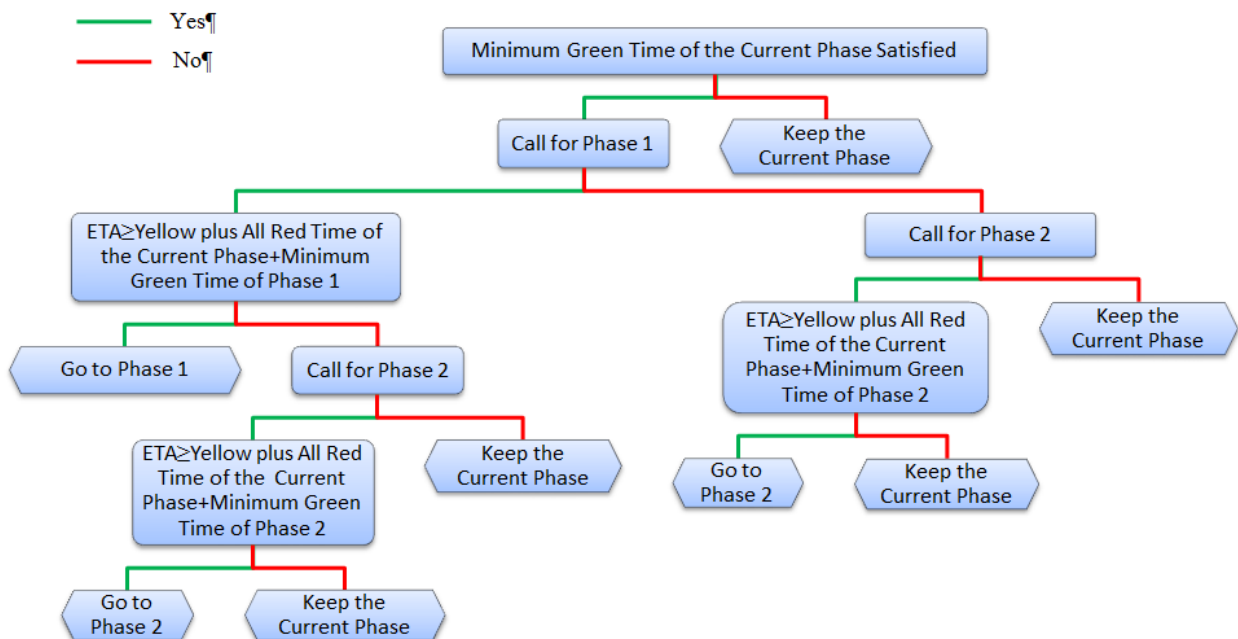

**Figure 7-25 Logic Algorithm of Modified ITPS Pre-Preemption Strategy When Current Phase Is Phase 3, 4, 5, or 6**

## Simplified Strategies

Even though previous studies showed that the ITPS is an effective pre-preemption strategy, it cannot be easily implemented in current signal control software and firmware. This study proposed a set of simplified pre-preemption strategies that are similar to the EWS strategy, which is implemented by using the low priority preemption features built into the controllers (Roberts and Brown-Esplain, 2005). Since these pre-preemption strategies use the build-in preemption function inside the signal controller, there is no abbreviation of the minimum green time allowed by the controller during the pre-preemption. However, unlike the EWS strategy, which considers only the phases during the pre-preemption, the simplified strategies proposed in this study also take the returning phase sequence into account.

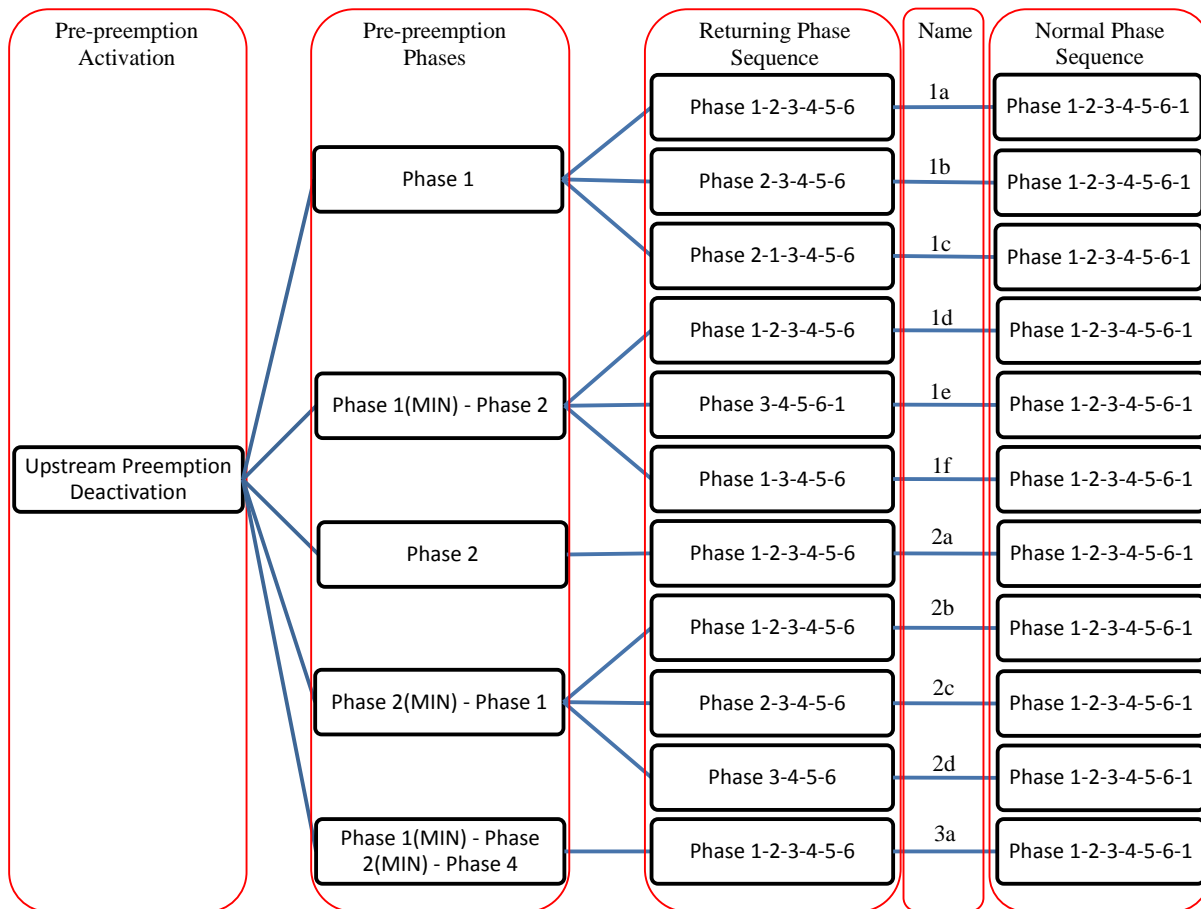

**Figure 7-26 Signal Phase Logic of Potential Simplified Pre-Preemption Strategies**

---

### 7.3.2 Simulation Results

The 13 strategies proposed in the previous sections were coded and tested in the VISSIM model. However, the results were found to be not significantly different from the base model without pre-preemption strategies. The reason is that the distance between the target intersection of I-95 interchange at W Commercial Blvd and the first upstream intersection of Powerline Rd at W Prospect Rd is too short to execute the proposed pre-preemption strategies. In the most cases, the regular preemption and CWT started before the activation of the pre-preemption strategies. Another problem in the models with base conditions was the confusion of the SB trains, since the abbreviations of the minimum green time and extra delays may be caused by the SB trains instead of NB trains. It is not straightforward to test the benefit of the pre-preemption strategies, as there is no such strategy developed for the SB trains because upstream preemption information for the SB trains was not available in this study. Although the abbreviations of minimum green time and delays caused by the SB trains can be differentiated from those caused by the NB trains by analyzing the signal/detector records, the SB trains were excluded in the later models just to simplify the case. The variation of the train speed in the simulation also made the analysis more complex. Therefore, the train speed was simulated to be constant in the later scenarios.

Based on the findings from the models with base conditions, the first upstream intersection of Powerline Rd at W Prospect Rd was moved along with the second upstream intersection of I-95 interchange at Oakland Park Blvd to a location approximately 5,000 feet from the target intersection of I-95 interchange at W Commercial Blvd. The distance between the first and the second upstream intersections remains the same as the existing condition (i.e., 6,100 feet). The SB trains were removed from the model and the train speed was set as fixed. In addition, for the purpose of testing, the NB trains are increased from 4 trains to 10 trains during the PM peak hours. The new train schedule is shown in Table 7-5 after increasing the frequency. The bold-face times in the table indicate the original departure times in the current condition. The pre-preemption strategies are coded in VAP and tested with train speeds at 30, 40, 50, and 60 mph, respectively. Each scenario was run 10 times with different random seeds.



---

**Table 7-5 Departure Time of NB Trains**

<b>Train No.</b>	<b>Departure time from Fort Lauderdale Station</b>
<b>1</b>	<b>3:59:00 PM</b>
2	4:10:00 PM
3	4:22:00 PM
4	4:33:00 PM
<b>5</b>	<b>4:47:00 PM</b>
6	4:58:00 PM
7	5:08:00 PM
<b>8</b>	<b>5:17:00 PM</b>
<b>9</b>	<b>5:37:00 PM</b>
10	5:48:00 PM

### **Safety Results**

The number of minimum green time abbreviations due to passing trains is shown in Table 7-6. After initial testing, it was found that some of the simplified strategies did not show improvements to the average intersection delays, and thus they were excluded from the comparison in Table 7-6. As can be seen from the table, the number of the minimum green time abbreviations in the scenarios with base conditions without a pre-preemption strategy (Column 2) becomes higher as the number of trains increases, as expected. The results also show that the number of minimum green time abbreviations do not have a correlation with the train speed for the base conditions. Simplified strategies 1d, 1e, and 2c performed well when the train speed was slower than 50 mph but resulted in minimum green time violations at high speeds. This may be because the available time for pre-preemption decreases with the increase in train speed, and, according to Figure 7-26, this available time may not be sufficient to serve the minimum green times of the two phases they were designed to serve during the pre-preemption. Pre-preemption strategy 3a violated the minimum green time, even when the trains were traveling at 40 mph (since this strategy is set to serve three phases during the pre-preemption). Based on the results, it can be concluded that the more phases a strategy tries to serve, the more likely the minimum green time will be violated. Based on the results from Table 7-6, only the ITPS, Modified ITPS, and simplified strategies 1b and 2a successfully avoided the abbreviation of minimum green times.

**Table 7-6 Number of Average Minimum Green-Time Abbreviations for 10 Runs\***

Scenario/ Strategy	Base	ITPS	Modified ITPS	Simplified Strategies										
				1a	1b	1c	1d	1e	1f	2a	2b	2c	2d	3a
40MPH4T	<b>1</b>	0	0	0	0	0	0	0	0	0	0	0	0	0
30MPH10T	<b>2</b>	0	0	-	0	-	0	0	-	0	-	0	-	-
40MPH10T	<b>2</b>	0	0	0	0	0	0	0	0	0	0	0	0	<b>2</b>
50MPH10T	<b>3</b>	0	0	-	0	-	<b>1</b>	<b>3</b>	-	0	-	<b>1</b>	-	-
60MPH10T	<b>2</b>	0	0	-	0	-	<b>4</b>	<b>6</b>	-	0	-	<b>1</b>	-	-

\* In Column 1, 40MPH4T, for example, means four trains traveling at 40 mph.

### Delay Results

The average intersection delays extracted from different scenarios are shown in Figure 7-27. It should be mentioned that the delays were extracted for each train, from the time that the pre-preemption was activated (i.e., when the immediate upstream preemption was deactivated) to three minutes after the deactivation of the target intersection preemption, with the purpose of avoiding the dilution of delays if including delays during normal signal operations. Three minutes afterward, the preemption deactivation was selected to ensure the collection of the delays of at least one cycle length following the end of the preemption, so as to test the effects of different returning phase sequences.

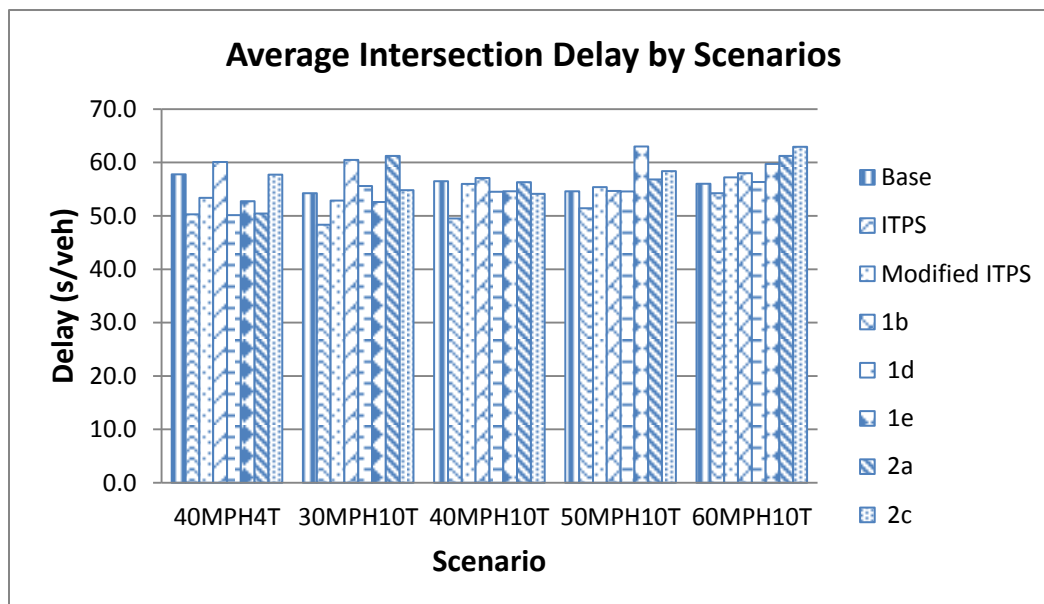

(Note: On the x-axis, 40MPH4T, for example, means four trains traveling at 40 mph)

**Figure 7-27 Average Intersection Delays by Scenarios**

---

It is noted that the ITPS, as shown in Figure 7-27, has the lowest delays in all scenarios found among the seven tested pre-preemption strategies. The Modified ITPS improved delays compared well to the base scenario when the train speed was not higher than 40 mph. Other pre-preemption strategies that guaranteed no violation of minimum green time are strategy 1b and strategy 2a, as mentioned earlier. While strategy 1b induced a higher delay than the base scenario, strategy 2a showed delay improvements only in the scenario with 4 trains traveling at 40 mph. Both strategy 1b and 2a increased the delays when the train speed was 30 mph. Since the two strategies served only one phase during the pre-preemption period, the green time of the served phase might be more than what should be provided if the train slowed down. Strategy 1d and 2c improved the delays only when the train speed was 40 mph. Strategy 1e lowered the delays, as long as the trains were travelling at or below 40 mph.

It is also worth mentioning that the queues back to the train track from the Powerline Rd/Commercial Blvd intersection, which is west of the target intersection, were observed multiple times in simulation with the implementation of strategy 1d when the approaching train was traveling at 30 mph. The queue includes the traffic from the NB left turn and WB through movements at the I-95/Commercial Blvd intersection. The green time for those two movements provided by strategy 1d during the pre-preemption might be excessive, as the train was traveling at a low speed, and thus the demand of those vehicles was not satisfied by the existing signal plan at the intersection of Powerline Rd at Commercial Blvd.

## **7.4 Summary**

This study tested various pre-preemption strategies using VISSIM simulation in the three control sections. Selected findings are as follows:

- Coordinated pre-preemption strategies can effectively reduce average delay along an arterial during the period of train blockage. However, the performance is sensitive to site configurations and pre-preemption parameters. Summarily, the coordinated pre-preemption strategies can guarantee positive performance in terms of reducing average delay in scenarios of high traffic volumes (Volume Level  $\geq 3$ ) and long train duration ( $\geq 100$  sec).
- The performance of the coordinated strategies in terms of average stops is also sensitive to site configurations. In Section I, the coordinated pre-preemptions are more likely to reduce the average stops under high traffic volumes (volume level  $\geq 3$ ). In Section II, the performance pattern is complex but still effective in most scenarios.

- The configuration of pre-preemption phases, including phase number, phase sequence, phase time, and offset, also impacts the performance of the strategies. Inappropriate parameters may lower the effectiveness of strategies and even worsen roadway operations in some scenarios. Thus, an optimization procedure is necessary to be developed for finding ideal parameters.
- It was found that the more complex algorithms, such as ITPS and Modified ITPS, which require the estimation of a train’s arrival time, successfully eliminate the abbreviation of the minimum green times. In terms of delays at individual intersections, ITPS produced the best results among the seven non-coordinated pre-preemption strategies in all scenarios. However, ITPS-based strategy experiences lower performance for the whole corridor comparing to coordinated pre-preemption.
- Considering applicability and effectiveness at corridor level (as shown in Table 7-7), the coordinated pre-preemption strategy is suggested for implementation in Florida.

A comparison of the tested pre-preemption strategies is given in Table 7-7.

**Table 7-7 Comparison of Pre-preemption Strategies**

	<b>Coordinated Pre-preemption</b>	<b>ITPS</b>	<b>Modified ITPS</b>
Optimization Objective	Whole corridor	Individual intersection	Individual intersection
Phase Mode	Pre-timed	Actuated	Actuated
Coordination?	Yes	No	No
Algorithm Complexity	Simple	Complex	Complex
Device Requirement	Standard NEMA Controller	Additional Logic Module	Additional Logic Module
Applicability	High	Low	Low
Major Advantages	<ul style="list-style-type: none"> <li>• Reduce delay</li> <li>• Reduce stops</li> <li>• Reduce queue length</li> </ul>	<ul style="list-style-type: none"> <li>• Eliminate abbreviation of minimum green times</li> <li>• Reduce delay</li> </ul>	<ul style="list-style-type: none"> <li>• Eliminate abbreviation of minimum green times</li> </ul>
Offline Optimization	Required	No	No

---

## 8 CONCLUSIONS AND RECOMMENDATIONS

### 8.1 Summary and Conclusions

This research project investigated the potential for using advance features of traffic signal system software platforms (ATMS.now), which is prevalently used in Florida, to alleviate safety and mobility problems at highway-railroad at-grade crossings and adjacent arterials. Pre-preemption phasing was developed in this study to provide “extra” green time to the movements blocked by a train before it arrives at a crossing in order to (1) mitigate congestion on the arterials nearby railways and (2) reduce conflicts of train-vehicle and/or vehicle-vehicle adjacent to at-grade crossings. This study explored the technologies for implementing key functions of a pre-preemption system, including train detection, train’s arrival prediction, pre-preemption control algorithms, and the capabilities of ATMS.now system. VISSIM-based simulation models were developed in this study based on three control sections along two railway corridors (FEC and CSX) in Broward County, Florida, to test the proposed pre-preemption strategies. A series of comparisons before-after implementing pre-preemption strategies were conducted to validate the effectiveness of pre-preemption strategies. Based on a comprehensive study of traffic signal pre-preemptions, close examinations of the ATMS.now software functionalities, and in-depth evaluations of various scenarios via intensive VISSIM microscopic simulation runs on two developed pre-preemption strategies, the following conclusions were obtained:

- Upstream preemption signals (activation or release) are suggested for triggering pre-preemptions at downstream intersections along a railroad corridor. The advantage of this technology is to eliminate the needs of retrieving train information from train companies or installing new train detectors. However, the technology is restricted by the availability of preemptions along the railroad corridors.
- The prediction of ETA is the key factor in the implementation of pre-preemptions and is the function of train speed and location of upstream preemptions. Due to the speed variance of trains, two or more preemptions are expected at upstream crossings, and the ideal space between the two crossings is less than 0.5 miles. An algorithm was developed in this study to predict ETA based on the preemption logs of the two crossings.
- Two pre-preemption strategies were developed and tested in this study: coordinated pre-preemption and ITPS-based pre-preemption. Coordinated pre-preemption aims to clear the through traffic along an arterial as much as possible before train’s arrival.

---

A coordinated phase should be included in its phase sequence. Since all pre-preemption phases are pre-timed, coordination pre-preemption is easy to implement on existing traffic controllers (e.g., NAZTEC 2070N). The ITPS-based strategy aims to reduce the number of minimum green time abbreviations at a preempted intersection in a fully-actuated manner. Because of the complex logic of the ITPS-based strategy, its implementation may require additional logic modules.

- Based on the simulation results, the coordinated strategy can effectively improve mobility on the arterials near a railroad crossing.
  - The strategy can reduce traffic delay along the arterials by 4–60 percent, according to geometric and traffic conditions.
- The coordinated strategy can effectively improve safety on the arterials near a railroad crossing.
  - The strategy can reduce average stops along the arterials by 10–45 percent, according to geometric and traffic conditions. Lower average stop numbers can smooth traffic and reduce the risk of rear-end crashes.
  - The strategy can reduce average queue length along the commuting direction on the arterials by up to 100 percent, according to geometric and traffic conditions. Shorter queue length can reduce the risk of a queue intruding into the next intersection.
- The performance pattern of the coordinated pre-preemptions is sensitive to site features and strategy configurations.
- ITPS-based pre-preemption strategies can reduce average delay and the number of minimum green time abbreviations at individual intersections. Considering the applicability and corridor-level performance of the two pre-preemption strategies, coordinated pre-preemption is suggested when traffic volume is higher than 500 vphpl and train block duration is longer than 100 seconds.
- A generic pre-preemption plan was developed in this study to provide guidance on implementation of the pre-preemption strategy using ATMS.now system in Florida. The generic plan details the procedure to (1) identify the needs of pre-preemptions; (2) activate pre-preemptions using upstream preemption signals; (3) predict ETA using upstream preemptions; and (4) configure ATMS.now to implement the pre-preemption strategy.

---

## 8.2 Recommendations for Implementation

Based on the conclusions, the recommendations for implementing the coordinated pre-emption strategy in Florida are given as follows.

### Train Detection and Pre-emption Trigger

As a cost-effective alternative to train detection and pre-emption trigger, upstream preemptions (hereafter, along the railway corridor) are suggested if the following conditions are satisfied:

- No other train detectors are available in the control section.
- The signalized intersections in the control section are connected to a traffic management system (such as ATMS.now).
- No train stations or other roadway facilities that interrupt train operations exist in the control section.
- At least one preempted intersection is available in the upstream from the target intersection.
- One upstream preemption signal can be used for pre-emption trigger in the target intersection if:
  - Train speed is nearly constant in the control station at the same time of a day, and
  - Train speed pattern can be obtained from railway companies.
- Two or more upstream preempted intersections are required if:
  - Train speed variety is significant in the control section.
  - Train speed pattern is unknown.  
*(Note: Train speed variety can be estimated using Eq. 3-6 based on historical preemption logs)*
  - The distance between the two preempted intersections is not greater than 0.5 miles.
- The distance between the upstream preempted intersection used as the pre-emption trigger and the target intersection should be less a reasonable value. The value, which is the function of train speed and its variance, can be estimated using Eqs. 3-1 to 3-6.

---

If these criteria cannot be satisfied, roadside train detectors are suggested.

### **Traveler Information**

ETA/ETD information can be provided to vehicle drivers through a Dynamic Message Signs (DMS).

- Two messages can be provided: the remaining time before train's arrival and the roadway blockage duration.
- The message should be given in a format of time intervals. For example, "Train will arrive in 2 – 3 minutes."
- Information can be disseminated to travelers through the FDOT SunGuide system.
  - A connection between the FDOT SunGuide and the ATMS.now is required.
  - The estimation of ETD/ETA can be developed as a new module of the FDOT SunGuide or imported from a third-party application into the SunGuide.

### **Implementation of Pre-preemption Strategy**

The coordinated pre-preemption strategy is suggested to be implemented if the following criteria are satisfied:

- Significant congestion and long queues can be observed along the urban arterial intersecting the railroad corridor.
- Train blockage duration is greater than 100 sec.
- Vehicle volume on the arterial is higher than 500 vphpl.
- Pre-preemption triggers are available in the control section.

### **Pre-preemption Timing**

- The signalized intersections along the intersecting arterial impacted by train blockage should be considered in the scope of pre-preemption coordination. The impact can be observed in the field, calculated using the queue theory, or simulated.
- The coordinated pre-preemption phase should be assigned to the commuting through-movements along the arterial.
- The non-coordinated pre-preemption phases should be considered if congestion occurs in turning movements or minor movements.



- 
- The timing parameters (phase sequence, phase length, and phase offset) should be optimized based on traffic demand and ETA.

### **Implementation of Pre-preemption using ATMS.now**

- Preempt 1 in a NAZTEC 2070 controller, which has the highest priority, should be reserved for preemption operations. Preempts 3–6 can be used for pre-preemption purposes.
- The current version of ATMS.now cannot estimate ETA/ETD due to its closed system structure. Secondary software (an external process) is needed to estimate ETA and/or ETD.
- The secondary software should be allowed to access the ATMS.now database to retrieve preemption logs and write incident triggers in the ATMS.now SQL database:
  - A READ permission is required for retrieving preemption logs and monitoring Upstream Preemption (Controller Alarm #49). This access will not change any information in the database.
  - A WRITE permission is required for writing an incident trigger in Incident Trigger Table, as the trigger of pre-preemption.
- The secondary software may be developed through three ways:
  - NAZTEC will develop an internal module to implement the ETA/ETD logic in ATMS.now.
  - FDOT or its contractors will develop a third-party application, which is independent to ATMS.now, to implement the ETA/ETD logic.
  - FDOT or its contractors will develop and integrate the ETA/ETD logic in the FDOT SunGuide system.

### **Estimation of Traffic Delay using ATMS.now**

To use ATMS.now to evaluate the performance of pre-preemption strategy, traffic counts at target intersections should be imported into the ATMS.now system.

## **8.3 Recommendations for Future Study**

Selected recommendations for future study include the following:

- The performance of coordinated pre-preemptions is sensitive to site features and pre-preemption parameters. It is necessary to develop a simulation-based

---

optimization procedure for optimizing pre-preemption parameters (phase types, phase sequence, phase time, and offset time) for special scenarios.

- More factors, except for traffic volume and train blockage duration, should be considered in future simulations to identify the impact of these factors (e.g., distance of the intersection from railroad crossing, train speed variance) on the performance of the pre-preemptions. The results can be used to improve the criteria for implementing pre-preemption in the generic plan.
- The pre-preemption strategy should be upgraded considering the following factors:
  - If a pedestrian movement is being serviced, its phase will not be truncated by a pre-preemption phase.
  - Blank-out signs for right-turn and left-turn movements onto railroad tracks should be used.
  - Consecutive preemptions from two separate trains in opposite direction at the grade crossings with two tracks should be considered cautiously.
- Hardware-in-loop (HIL) traffic simulation uses real traffic signal controller hardware to control simulated traffic. This simulation is done by interfacing a traffic simulation model with one or more traffic signal controllers. The traffic simulation model is a computer model of the interaction of vehicles with each other, vehicles with the roadway, and vehicles with the traffic control system. In most traffic simulation models, the traffic control system is emulated in software, but with HIL simulation, the emulated traffic control system is replaced with real traffic control hardware. In future, an HIL system that integrates ATMS.now is suggested to test and demonstrate the performance of the pre-preemptions in an actual environment.
- A pilot project is suggested. The purposes of the pilot project are to: (1) validate the technical feasibility and maturity for implementing pre-preemptions using ATMS.now; (2) demonstrate the implementation of pre-preemption strategies in a selected site; and (3) accumulate experience for implementing the pre-preemption strategies widely. The pilot project is suggested to include, but not limit to, the following tasks:
  - Develop the ETA/ETD estimation process (an internal module in ATMS.now, a third-party software developed a contractor, or an additional module in FDOT SunGuide)

- 
- Select a railway corridor which meets the pre-preemption implementation criteria.
  - Develop a site-specific pre-preemption phase timing
  - Implement a pre-preemption strategy in the selected railway corridor
  - Update the generic pre-preemption plan based on the experience collected in the pilot project.
  - Collect performance measures and evaluate the implementation of the pre-preemption strategy.

---

## BIBLIOGRAPHY

1. Code of Federal Regulations. Title 49, Part 234.225. Activation of Warning Systems. 2011.
2. Cho, Hanseon, and Laurence R. Rilett. Improved Transition Preemption Strategy for Signalized Intersections near At-Grade Railway Grade Crossing. *Journal of Transportation Engineering* 133(8) (2007): 443-454.
3. Datta, T., Gates, T. J., Savolainen, P. T., Fawaz, A., & Chaudhry, A. Timing Issues for Traffic Signals Interconnected with Highway-Railroad Grade Crossings. Final Report # RC-1578, Michigan Department of Transportation, Lansing, MI, 2013.
4. Federal Highway Administration (FHWA). *Manual on Uniform Traffic Control Devices*. Washington, DC, 2009.
5. Florida Department of Transportation. Highway-Rail Grade Crossing Safety Action Plan. Florida Department of Transportation, Tallahassee, FL, 2011.
6. Korve, H. NCHRP Synthesis of Highway Practice 271: Traffic Signal Operations near Highway-Rail Grade Crossings. Washington, DC: TRB, National Research Council, 1999.
7. Long, G. Clearance Time Requirements at Railroad-Preempted Traffic Signals. Florida Department of Transportation, Tallahassee, FL, 2002.
8. Roberts, Craig A., and Jamie Brown-Esplain. Congestion Mitigation at Railroad-Highway At-Grade Crossings. Research Report, Arizona Department of Transportation, Casa Grande, AZ, 2005.
9. Ruback, Leonard G., Kevin Balke, and Roelof Engelbrecht. Non-Vital Advance Rail Preemption of Signalized Intersections Near Highway-Rail Grade Crossings. Texas Department of Transportation, Austin, TX, 2007.
10. Traffic Engineering Council Committee. Preemption of Traffic Signals Near Railroad Crossings. Institute of Transportation Engineers (ITE), 2003.
11. Venglar, P.S., M.S. Jacobson, S.R. Sunkari, R.J. Engelbrecht, and T. Urbanik. Guide for Traffic Signal Preemption near Railroad Grade Crossing. Texas Department of Transportation, Austin, TX, 2000.
12. Venglar, Steven. Advanced Intersection Controller Response to Railroad Preemption. Texas Transportation Institute, Texas A&M University, College Station, TX, 2000.

## APPENDIX: CASE STUDY TO PREDICT ONSET AND REMOVAL OF PREEMPTIONS

The methodology to predict the onset and removal of preemption using only historical data and real time data is illustrated in this case study.

**Step 1:** As discussed earlier, at least one of historical preemption activity data needs to be collected and analyzed to generate median preemption times (duration of preemption at each grade crossing) and median travel times (time differential between the removals of preemptions for two successive grade crossings). Based on the data collected in the South Florida Rail (SFR) Corridor, Table A-1 illustrates the median preemption times and median travel times for the AM peak, off peak, and PM peak.

**Table A-1 Median Preemption and Link Travel Time for Northbound Direction for SFR Corridor**

	Grade Crossing Name	Median Preemption Duration				Link Length	Median Link Travel Time			
		AM	Off	PM	All		AM	Off	PM	All
Grade Crossing 1	W Oakland Park Blvd	0:00:48	0:00:57	0:00:57	0:00:57	5966 2748	0:00:42	0:00:49	0:00:42	0:00:45
Grade Crossing 2	Prospect Road	0:01:00	0:01:03	0:01:01	0:01:02					
Grade Crossing 3	Commercial Blvd	0:00:56	0:00:49	0:00:48	0:00:49					
Grade Crossing 4										
Grade Crossing 5										

**Step 2:** Take an example of a preemption activity in the SFR corridor. Table A-2 illustrates the preemption activity for a train at about 7:00 AM on January 10, 2013.

**Table A-2 Example of Preemption Activity for Northbound Train in SFR Corridor**

	Preemption ON	Preemption OFF
W Oakland Park Blvd	7:10:21	7:11:05
Prospect Rd	7:11:02	7:12:03
Commercial Blvd	7:11:41	7:12:29

**Step 3:** The objective now is to use the historical data in Table A-2 and real-time data to predict the onset of preemption events. Since we are relying only on the activation of the first preemption to know that a train is in the corridor, the first prediction will rely completely on historical data when preemption is activated at Oakland Park Blvd, which is designated as Event 1. Hence, at Event 1, the remaining events (Events 2–6) are predicted based on historical data in Table A-2. At subsequent events, for example, at Event 2, the remaining events are corrected by the error observed at Event 2. In this case, Event 2 was

predicted to occur at 7:11:03. However, it actually occurred at 7:11:02, an error of 1 second. Hence, at Event 2, the remaining events are corrected by 1 second. The errors in the prediction for each event at various stages are illustrated in parenthesis in Table A-3.

**Table A-3 Example of Prediction of Preemption Activities Based on Historical Data and Corrections Based on Real-Time Data**

<b>Event #</b>	<b>Stage</b>	<b>Predictions at Event 1</b>	<b>Predictions at Event 2</b>	<b>Predictions at Event 3</b>	<b>Predictions at Event 4</b>	<b>Predictions at Event 5</b>
<b>2</b>	Onset of preemption at Prospect Rd	7:11:03 (+0:00:01)	-	-	-	-
<b>3</b>	Release of preemption at W Oakland Park Blvd	7:11:09 (+0:00:04)	7:11:08 (+0:00:03)	-	-	-
<b>4</b>	Onset of preemption at Commercial Blvd	7:11:27 (-0:00:14)	7:11:26 (-0:00:15)	7:11:23 (-0:00:18)	-	-
<b>5</b>	Release of preemption at Prospect Rd	7:12:03 (0:00:00)	7:12:02 (-0:00:01)	7:11:59 (-0:00:04)	7:12:17 (+0:00:14)	-
<b>6</b>	Release of preemption at Commercial Blvd	7:12:23 (-0:00:06)	7:12:22 (-0:00:07)	7:12:19 (-0:00:10)	7:12:37 (+0:00:08)	7:12:22 (-0:00:07)

The exercise of predicting the onset of preemption activities using only historical data and real-time preemption data can show mixed results, as illustrated in Table A-3. Prediction of some preemption activities are more accurate than others and depend on the behavior of the train. However, the train behavior is not observed until the train activates a minimum of 2–3 events. Hence, such a methodology is still effective to implement pre-preemption strategies that can be deployed reasonably quickly and that can tolerate some errors in the prediction of preemption events.