

Final Report FDOT Project BDK78 977-19

Demonstration Bio Media for Ultra-urban Stormwater Treatment



Project Manager
Rick Renna, P.E. State Hydraulics Engineer

Submitted by

Martin Wanielista, Ni-Bin Chang, Andrew Randall,
Manoj Chopra, Mike Hardin, Jamie Jones, Andrew Hood, and Sultan Salamah



Managed Stormwater is Good Water

Stormwater Management Academy
Civil, Environmental, and Construction Engineering Department
University of Central Florida
Orlando, FL 32816

May 2014

DISCLAIMER

The opinions, findings, and conclusions expressed in this publication are those of the authors and not necessarily those of the State of Florida Department of Transportation.

METRIC CONVERSIONS

SYMBOL	WHEN YOU KNOW	MULTIPLY BY	TO FIND	SYMBOL
LENGTH				
In	Inches	25.4	Millimeters	Mm
Ft	Feet	0.305	Meters	M
Yd.	Yards	0.914	Meters	M
MI	Miles	1.61	Kilometers	km

SYMBOL	WHEN YOU KNOW	MULTIPLY BY	TO FIND	SYMBOL
AREA				
in ²	square inches	645.2	square millimeters	mm ²
ft ²	square feet	0.093	square meters	m ²
yd ²	square yard	0.836	square meters	m ²
Ac	Acres	0.405	Hectares	ha
mi ²	square miles	2.59	square kilometers	km ²

SYMBOL	WHEN YOU KNOW	MULTIPLY BY	TO FIND	SYMBOL
VOLUME				
fl. oz.	fluid ounces	29.57	Milliliters	ml
Gal	Gallons	3.785	Liters	L
ft ³	cubic feet	0.028	cubic meters	m ³
CY	cubic yards	0.765	cubic meters	m ³
NOTE: volumes greater than 1000 L shall be shown in m ³				

SYMBOL	WHEN YOU KNOW	MULTIPLY BY	TO FIND	SYMBOL
MASS				
Oz	Ounces	28.35	Grams	G
Lb.	Pounds	0.454	Kilograms	kg
T	Short tons (2000 lb.)	0.907	mega grams (or "metric ton")	mg (or "t")

SYMBOL	WHEN YOU KNOW	MULTIPLY BY	TO FIND	SYMBOL
TEMPERATURE (exact degrees)				
°F	Fahrenheit	5 (F-32)/9 or (F-32)/1.8	Celsius	°C

APPROXIMATE CONVERSIONS TO SI UNITS

SYMBOL	WHEN YOU KNOW	MULTIPLY BY	TO FIND	SYMBOL
LENGTH				
mm	Millimeters	0.039	Inches	in
M	Meters	3.28	Feet	ft.
Km	Kilometers	0.621	Miles	mi

SYMBOL	WHEN YOU KNOW	MULTIPLY BY	TO FIND	SYMBOL
AREA				
mm ²	square millimeters	0.0016	square inches	in ²
m ²	square meters	10.764	square feet	ft ²
m ²	square meters	1.195	square yards	yd ²
Ha	Hectares	2.47	Acres	ac
km ²	square kilometers	0.386	square miles	mi ²

SYMBOL	WHEN YOU KNOW	MULTIPLY BY	TO FIND	SYMBOL
VOLUME				
mL	Milliliters	0.034	fluid ounces	fl. oz.
L	Liters	0.264	Gallons	gal
m ³	cubic meters	35.314	cubic feet	ft ³
m ³	cubic meters	1.307	cubic yards	CY

SYMBOL	WHEN YOU KNOW	MULTIPLY BY	TO FIND	SYMBOL
MASS				
G	Grams	0.035	Ounces	oz.
Kg	Kilograms	2.202	Pounds	lb.
Mg (or "t")	mega grams (or "metric ton")	1.103	Short tons (2000 lb.)	T

SYMBOL	WHEN YOU KNOW	MULTIPLY BY	TO FIND	SYMBOL
TEMPERATURE (exact degrees)				
°C	Celsius	$1.8C+32$	Fahrenheit	°F

TECHNICAL REPORT DOCUMENTATION

1. Report No.	2. Government Accession No.	3. Recipient's Catalog No.	
4. Title and Subtitle Demonstration Bio Media for Ultra-urban Stormwater Treatment		5. Report Date May 2014	
		6. Performing Organization Code University of Central Florida	
7. Author(s) Martin Wanielista, Ni-Bin Chang, Mike Hardin, Andrew Randall, Manoj Chopra, Jamie Jones, Andrew Hood and Sultan Salamah		8. Performing Organization Report No. SMA 1660 7051	
9. Performing Organization Name and Address Stormwater Management Academy University of Central Florida Orlando, FL 32816		10. Work Unit No. (TRAIS)	
		11. Contract or Grant No. BDK78 977-19	
12. Sponsoring Agency Name and Address Florida Department of Transportation 605 Suwannee Street, MS 30 Tallahassee, FL 32399		13. Type of Report and Period Covered Final Report Sep. 7, 2012 – Mar. 4, 2014	
		14. Sponsoring Agency Code	
15. Supplementary Notes			
16. Abstract <p>In ultra-urban areas, there is limited aboveground space for stormwater facilities. Limited space to build both roadways and stormwater facilities results in excessively high construction costs. To complete a roadway, frequently selected are alternate roadway corridors to keep construction cost within budget. One technique used by transportation engineers to construct roadways and stormwater facilities in ultra-urban areas with limited space is to build underground facilities and use a highly effective sorption material called BAM (Biosorption Activated Media) to trap pollutants. The information in this report addresses the life expectancy of the media for nutrient removal as well as a documentation of the chemical and biological mechanisms for removal. The form of BAM used is BOLD & GOLD™. Laboratory experimentation shows that the probable causes for nitrogen and phosphorus removal are sorption and precipitation. In addition, removal of nitrogen occurs biologically if converted to gas in the form of nitrate.</p> <p>Researchers conducted experiments using BAM in underground detention facilities in ultra-urban environments. Two general filtration options were used, namely an on-line filter and an off-line filter. The authors monitored full-scale operating filters for the removal of total and dissolved nutrients as well as for copper and zinc. The results of the nutrient and metal monitoring showed the filters operated as designed, if regularly maintained. For maintenance purposes, keep the filters clear of solids that cause filtration rate to decrease and replace the media when it is exhausted. The authors present an example problem that showed how to calculate the volume of media needed to achieve the frequency of replacement required for regulatory certification.</p>			
17. Key Word Filtration, Ecology, Media, Effectiveness, Stormwater, Pollution Control, Nutrients.		18. Distribution Statement No Restrictions	
19. Security Classification. (of this report) Unclassified	20. Security Classification. (of this page) Unclassified	21. No. of Pages 159	22. Price

ACKNOWLEDGMENTS

The authors deeply appreciate all of the support from so many dedicated professionals for this project. To complete the research, 14 people were involved.

First, the authors would like to thank engineers at the Florida Department of Transportation for their technical assistance and financial support. Without their support, research such as this would not be possible. In particular, Rick Renna provided valuable assistance in the development and conduct of the research activities. This work is under the guidance of the Stormwater Management Academy located at the University of Central Florida. The staff and students of the Academy provided valuable assistance in the collection and analyses of laboratory and field data.

Many individuals from the FDOT Deland and Ocala offices supported the field demonstrations. In addition, the authors appreciate the design assistance from Tim Walsh of CH2MHill, Inc. and Tom Happel of Suntree Technologies, Inc. We are grateful for the input provided by FDOT engineers, consulting engineering and manufacturers who provided design and field implementation details.

EXECUTIVE SUMMARY

Stormwater facilities located in dense urban areas, called “ultra-urban areas,” can be difficult and costly to construct or to retrofit due to space limitations, high pollutant loadings, high peak flows, traffic management, and utility conflicts. In addition, ultra-urban environments are typically much more challenging in terms of meeting receiving water quality conditions. Consequently, FDOT potentially faces costly solutions to reduce pollution in ultra-urban environments.

Biosorption Activated Media (BAM) is one option FDOT can use to reduce pollution within stormwater facilities that operate in ultra-urban areas. The regulatory community in Florida has accepted BAM. BAM is a solid material and many forms are mineral in nature and thus do not decay significantly with time. BAM can last over 20 years in its original form. BAM is capable of removing some forms of nutrients and certain metals in stormwater by chemical means, primarily by sorption and precipitation mechanisms. Furthermore, BAM can be a filtration mechanism for the removal of the nutrient or metal in a particulate form. In addition, BAM is able to attract and remove bacteria because of its significant surface area that attracts biological organisms. These organisms can convert certain nutrients into cell mass and gases. One BAM mix developed in Florida is called **BOLD & GOLD™**. **BOLD & GOLD™** is primarily mineral and does not decay. It is the mix used for assessment of removal mechanisms as well as for field demonstration in this report.

In addition to sorption and biological removal, there are potentially other removal mechanisms. Thus, this report identifies other chemical and physical mechanisms as well

as those by sorption and biological means. The authors used laboratory experiments to identify and support the chemical and biological removal mechanisms. For nitrogen removal in the nitrate form, biological denitrification was the primary means as identified by the laboratory experiments.

The authors used two field sites to demonstrate the use of **BOLD & GOLD™**. One site, located in Kissimmee, Florida, used an on-line or pass-through type of best management practice (BMP), which was a modified nutrient removal baffle box using an up-flow filter with **BOLD & GOLD™**. The other site, located in Dunnellon, Florida, used an off-line filter filled with **BOLD & GOLD™** with flow diversion. Both filter locations received runoff water from ultra-urban environments. The ultra-urban watersheds are nearly 100% impervious. This report documents the removal effectiveness of these filters.

The authors present an example problem to calculate the volume of **BOLD & GOLD™** needed to achieve a specified removal. To determine the replacement time of the media, used was the removal mass of Ortho-Phosphate per unit weight of media. Two years was the assumed replacement time in the example because it is the certification time required by the water management districts in the State. Presented at the time of certification is a documentation of performance or a replacement of media. In most cases, it is less expensive to replace the media. Increased replacement time was possible under contract agreement with regulatory agencies, but underground space and budget must be available to implement the larger filtration system.

Estimated were the removals for both the demonstration on-line and off-line best management practices systems. Maintenance of the systems reduced clogging and thus minimized by-pass of the filter. In addition, the maintenance also minimized re-suspension of settled and impinged materials on screening devices. The removal estimates for phosphorus were for sorption media that was within life expectancy. Thus, the reported removals were for favorable operating conditions. For the two demonstration systems, the average removal for total nitrogen and total phosphorus using both sedimentation, screening and media filtration, ranged from 67-76% and 75-77%, respectively. The removal attributed to the filter for total nitrogen and total phosphorus ranged from 45-60% and 46-58%, respectively. From the metal samples, recorded were below detection limits for lead, 35% removal of copper and 31% removal of zinc. Total suspended solids removal for the system ranged from 81-83%. Negative removals were recorded when backwater conditions existed. Thus, designs to minimize backwater should be mandatory. During the reported sampling periods, backwaters occurred about 20 % of the time. Comparing removals from the laboratory experiments with those from the field demonstrations showed the laboratory experiments had greater removals. However, used for the laboratory results was strict flow controls.

TABLE OF CONTENTS

DISCLAIMER..... ii

METRIC CONVERSIONS..... iii

APPROXIMATE CONVERSIONS TO SI UNITS iv

TECHNICAL REPORT DOCUMENTATION..... vi

ACKNOWLEDGMENTS vii

EXECUTIVE SUMMARY viii

LIST OF FIGURES xiv

LIST OF TABLES xvii

CHAPTER 1: INTRODUCTION 1

1.1 BACKGROUND 1

1.2 OBJECTIVES 2

 1.2.1 Questions for Laboratory Investigations..... 2

 1.2.2 Questions for Field Demonstrations Using Underground Applications 2

1.3 LIMITATIONS..... 3

CHAPTER 2: PAST WORK WITH ULTRA-URBAN ENVIRONMENTS..... 4

2.1 A DEFINITION OF ULTRA-URBAN ENVIRONMENTS 4

2.2 WATER QUALITY PARAMETERS OF CONCERN..... 4

2.3 MEDIA FILTERS..... 6

 2.3.1 Sand Media Systems 7

 2.3.2 Mixed Media Systems..... 8

 2.3.3 Engineered Media Systems..... 8

CHAPTER 3: BASIC REMOVAL MECHANISMS 10

3.1 OBJECTIVE 10

3.2 EXPERIMENTAL DESIGN: BAM COMPOSITIONS 10

3.3 EXPERIMENTAL DESIGN: COLUMN SYSTEMS AND ANALYSIS 11

 3.3.1 Column Set-Up 11

 3.3.2 Column Operations 12

3.4 SAMPLING AND MEASUREMENTS 14

3.5 RESULTS 15

 3.5.1 Nitrogen 16

 3.5.2 Dissolved Oxygen 24

3.5.3 Phosphorus.....	24
3.5.4 Dissolved Organic Carbon.....	25
3.5.5 Turbidity	26
3.5.6 Total Suspended Solids.....	27
3.5.7 pH.....	28
3.5.8 Alkalinity	30
3.5.9 Temperature.....	31
3.5.10 Bacteria	32
3.5.11 Equilibrium Isotherm (i.e. Adsorption) Experiments	35
CHAPTER 4: PHYSIO-CHEMICAL PROPERTY CHARACTERIZATION OF BAM FOR NUTRIENT REMOVAL	50
4.1 INTRODUCION	50
4.2 CHAPTER OBJECTIVES.....	54
4.3 METHODOLOGIES.....	55
4.3.1 Isotherm Tests.....	56
4.3.2 Material Characterization.....	57
4.3.3 Breakthrough Column Tests	58
4.3.4 Statistical Analysis.....	60
4.4 RESULTS AND DISCUSSION.....	63
4.4.1 Material Characterization.....	63
4.4.2 Isotherm Results.....	64
4.4.3 Column Test and Thomas Model Results.....	74
4.4.4. Statistical Analysis of Results.....	80
4.5 REMARKS	81
CHAPTER 5: TESTING OF SORPTION MEDIA FOR NUTRIENT REMOVAL USING STORMWATER CONDITIONS	83
5.1 INTRODUCTION.....	83
5.1.1 Science Questions	88
5.1.2 Objectives	88
5.2 METHODOLOGIES	89
5.2.1 Column Tests	89
5.2.2 Batch Tests.....	92
5.2.3 Statistical Analyses	93

5.2.3 Scanning Electron Microscopy (SEM)	95
5.3 RESULTS AND DISCUSSION	96
5.3.1 Thomas Models.....	96
5.3.2 Batch Test Results.....	99
5.3.3 Statistical Analysis.....	101
5.4 SCANNING ELECTRON MICROSCOPY (SEM).....	101
5.5 FACTORS AFFECTING BIOFILM	105
5.6 FINAL REMARKS.....	110
CHAPTER 6: DEMONSTRATIONS.....	112
6.1 INTRODUCTION	112
6.2 OFF-LINE SORPTION MEDIA FILTRATION	112
6.3 ON-LINE SORPTION MEDIA FILTRATION	117
6.4 WATER QUALITY EFFECTIVENESS.....	120
6.4.1 Off-Line sorption filter test results	120
6.4.2 On-Line sorption filter test results	122
CHAPTER 7: CONCLUSIONS AND RECOMMENDATIONS	127
7.1 THE PROBLEM.....	127
7.2 CONCLUSIONS	127
7.3 DESIGN EXAMPLE WITH COST	128
7.4 RECOMMENDATIONS.....	131
REFERENCES.....	133
APPENDIX A	135

LIST OF FIGURES

Figure 3-1 Percent Average Removal of TN for each Media Type – Two-Hour Event; Average EBCT of 21.9 minutes (9/24/2013 – 11/18/2013)	18
Figure 3-2 Percent Average Removal of TN for each Media Type – 24-Hour Event; Average EBCT of 234.8 minutes (9/24/2013 – 11/18/2013)	19
Figure 3-3 EBCT versus Total Nitrogen Removal Efficiency	23
Figure 3-4 Hydraulic Loading versus Total Nitrogen Removal Efficiency	23
Figure 3-5 SRP adsorbed as a function of BAM mass for the Two-hour and 12-hour runs	37
Figure 3-6 Langmuir graph for the two-hour run	39
Figure 3-7 Langmuir graph for the 12-hour run	39
Figure 3-8 Langmuir graph for the 12-hour test run (50-100 g media only)	40
Figure 3-9 SRP Time Series For 50 grams of Media	41
Figure 3-10 SRP adsorbed as a function of the initial concentration for the 24-hour tests	44
Figure 3-11 q (mg/mg) versus equilibrium SRP concentration for the 24-hour tests	44
Figure 3-12 Orthophosphorus Freundlich Isotherm run 24-hour - 1	45
Figure 3-13 Orthophosphorus Freundlich Isotherm run 24-hour - 2	46
Figure 3-14 Orthophosphorus Langmuir Isotherm run 24-hour - 1	47
Figure 3-15 Orthophosphorus Langmuir Isotherm run 24-hour	47
Figure 4-1 Schematic set up of the triplicate column study	60
Figure 4-2 Langmuir isotherm data for BAM Nutrient mix 3-1 for (a) orthophosphate and (b) total soluble phosphorus	67
Figure 4-3 Freundlich isotherm data for BAM Nutrient mix 3-1 for (a) orthophosphate and (b) total soluble phosphorus	67
Figure 4-4 Langmuir isotherm data for BAM Nutrient mix 3-2 for (a) orthophosphate and (b) total soluble phosphorus for a 12-hour contact time	68
Figure 4-5 Freundlich isotherm data for BAM Nutrient mix 3-2 for (a) orthophosphate and (b) total soluble phosphorus for a 12-hour contact time	68
Figure 4-6 Langmuir isotherm data for BAM Nutrient mix 3-2 for (a) orthophosphate and (b) total soluble phosphorus using a 1-hour contact time	71
Figure 4-7 Langmuir isotherm data for BAM Nutrient mix 3-2 for (a) orthophosphate and (b) total soluble phosphorus using a 0.5-hour contact time	71

Figure 4-8 Plot of $\ln(C_o/C_e - 1)$ vs. time for BAM nutrient mix 3-2 using phosphorus solution with an initial PO_4 concentration of $1.0 \text{ mg}\cdot\text{mL}^{-1}$ and flow rate of $0.529 \text{ l}\cdot\text{hr}^{-1}$ used to derive values for the Thomas Model..... 75

Figure 4-9 Plot of $\ln(C_o/C_e - 1)$ vs. time for BAM nutrient mix 3-2 using phosphorus solution with an initial PO_4 concentration of $0.5 \text{ mg}\cdot\text{mL}^{-1}$ and flow rate of $0.529 \text{ l}\cdot\text{hr}^{-1}$ used to derive values for the Thomas model 75

Figure 4-10 Plot of $\ln(C_o/C_e - 1)$ vs. time for BAM nutrient mix 3-2 using phosphorus solution with an initial PO_4 concentration of $1.0 \text{ mg}\cdot\text{mL}^{-1}$ and flow rate of $0.167 \text{ l}\cdot\text{hr}^{-1}$ used to derive values for the Thomas Model..... 76

Figure 4-11 Thomas model of breakthrough column with BAM nutrient mix 3-2 using Initial PO_4 concentration of $1 \text{ mg}\cdot\text{mL}^{-1}$ and flow rate of $0.529 \text{ L}\cdot\text{hr}^{-1}$. Experimental data are the average effluent concentrations of the three columns 77

Figure 4-12 Thomas Model of Breakthrough Column with BAM nutrient mix 3-2 Using Initial PO_4 Concentration of $0.5 \text{ mg}\cdot\text{L}^{-1}$ and Flow Rate of $0.529 \text{ L}\cdot\text{hr}^{-1}$. Experimental data are the average effluent concentrations of the three columns 77

Figure 4-13 Thomas Model of Breakthrough Column with BAM nutrient mix 3-2 Using Initial PO_4 Concentration of $1 \text{ mg}\cdot\text{L}^{-1}$ and Flow Rate of $0.167 \text{ L}\cdot\text{hr}^{-1}$. Experimental data are the average effluent concentrations of the three columns 78

Figure 5-1 Experimental Setup of the Biological Testing 90

Figure 5-2 Phase 1 of Testing to Determine the Physiochemical Equilibrium Adsorption Capacity and Kinetics. This investigates the initial physiochemical adsorption of the media using spiked pond water 91

Figure 5-3 Phase 2 of Biological Testing to Determine the Biological Growth and Kinetics of the Developing Biofilm. This Involves the Continuous Run and Batch Tests with SEM..... 92

Figure 5-4 Plot of $\ln(C_o/C_e - 1)$ vs. time for BAM Nutrient mix 3-2 using spiked phosphorus pond water with an initial PO_4 concentration of $1.0 \text{ mg}\cdot\text{mL}^{-1}$ and flow rate of $0.167 \text{ l}\cdot\text{hr}^{-1}$ used to derive values for the Thomas Model 94

Figure 5-5 Schematic Drawing Scanning Electron Microscopy (University of Iowa, 2013)..... 96

Figure 5-6 Thomas Model of Breakthrough Column with BAM Nutrient mix 3-2 Using Initial PO_4 Concentration of $1 \text{ mg}\cdot\text{mL}^{-1}$ and Flow Rate of $0.167 \text{ L}\cdot\text{hr}^{-1}$. Experimental data are the average effluent concentrations of the three columns 97

Figure 5-7 Concrete Sand shown in SEM at (a) 350 x, (b) 1,100 x, and (c) 1,200 x magnification showing the surface structure and characteristics after residing in the 24 days of column testing..... 103

Figure 5-8 Fine Expanded Clay shown in SEM at (a) 140 x, (b) 1,600 x, and (c) 2,200 x magnification showing the surface structure and characteristics after residing in the 24 days of column testing..... 104

Figure 5-9 Tire crumb shown in SEM at (a) 140 x, (b) 1,600 x, and (c) 2,200 x magnification showing the surface structure and characteristics after residing in the 24 days of column testing..... 105

Figure 5-10 Effluent Concentrations Subjected to Spiked Pond Water with Influent PO₄, NH₃, and NO₃ Concentrations of 1 mg·mL⁻¹-P, 0.5 mg·mL⁻¹-N, and 0.5 mg·mL⁻¹-N, respectively, and Flow Rate of 0.167 L·hr⁻¹ using BAM Nutrient mix 3-2. Averaged Concentrations of the three columns..... 106

Figure 5-11 Orthophosphate Effluent Concentrations Subjected to Spiked Pond Water with Influent Total P Concentration of 1.04 mg·mL⁻¹ and Flow Rate of 0.167 L·hr⁻¹ using BAM Nutrient mix 3-2. Averaged Concentrations of the three columns 107

Figure 5-12 Total Phosphorus Effluent Concentrations Subjected to Spiked Pond Water with Influent PO₄ Concentration of 1 mg·mL⁻¹-P and Flow Rate of 0.167 L·hr⁻¹ using BAM Nutrient mix 3-2. Averaged Concentrations of the three columns 107

Figure 5-13 Ammonia Effluent Concentrations Subjected to Spiked Pond Water with Influent Ammonia Concentration of 0.5 mg·mL⁻¹ and Flow Rate of 0.167 L·hr⁻¹ using BAM Nutrient mix 3-2. Averaged Concentrations of the three columns 108

Figure 5-14 Nitrate Effluent Concentrations Subjected to Spiked Pond Water with Initial NO₃ Concentration of 0.5 mg·mL⁻¹-N and Flow Rate of 0.167 L·hr⁻¹ using BAM Nutrient mix 3-2. Averaged Concentrations of the three columns 109

Figure 5-15 Total Nitrogen Effluent Concentrations Subjected to Spiked Pond Water with Flow Rate of 0.167 L·hr⁻¹ using BAM Nutrient mix 3-2. Concentrations are average values 110

Figure 6-1 Diagram of the Up-flow Off-Line Sorption Filter (Front View) 113

Figure 6-2 Diagram of the Up-flow Off-Line Sorption Filter (Side View)..... 114

Figure 6-3 Diagram of the Diversion Structure for the Up-flow Off-Line Sorption Filter 114

Figure 6-4 Impervious Catchment area (green color) to off-line Sorption Filter 115

Figure 6-5 Up-flow Off-Line Sorption Filter before Media Placement 116

Figure 6-6 Up-flow Off-Line Sorption Filter after Media Placement 117

Figure 6-7 Diagram of Up-flow On-Line Sorption Filter during Low Flow 118

Figure 6-8 Diagram of Up-flow On-Line Sorption Filter during High Flow 118

Figure 6-9 Actual Operation of On-Line Sorption Filter during Low Flow 119

Figure 6-10 Impervious Catchment Area to On-line Sorption Filter..... 120

LIST OF TABLES

Table 3-1 BAM Compositions.....	11
Table 3-2 Column Types	11
Table 3-3 Phosphorus Species Removal - Average EBCT & Hydraulic Loading Rates for Two-Hour Tests (4/1/2013 – 11/18/2013) with EBCT = 22.9 minutes	12
Table 3-4 Phosphorus Species Removal - Average EBCT & Hydraulic Loading Rates for 24-Hour Tests (4/1/2013 – 11/18/2013) with Average EBCT=230 minutes	13
Table 3-5 Nitrogen Species Removal - Average EBCT & Hydraulic Loading Rates for Two-Hour Tests (9/24/2013 – 11/18/2013) with EBCT = 21.9 minutes	13
Table 3-6 Nitrogen Species Removal - Average EBCT & Hydraulic Loading Rates for 24-Hour Tests (9/24/2013 – 11/18/2013) with EBCT = 234.8 minutes.....	14
Table 3-7 Chemical analysis methods run at ERD (Oviedo, Florida).....	15
Table 3-8 Nitrogen Transformation and Removal: Two-Hour Storm Event; Average EBCT of 21.9 minutes (9/24/2013 – 11/18/2013).....	17
Table 3-9 Nitrogen Transformation and Removal: 24-Hour Storm Event; Average EBCT of 234.8 minutes (9/24/2013 – 11/18/2013).....	19
Table 3-10 Average Nitrogen Transformation and Removal for each Media: Comparison of Two-Hour & 24-Hour Events (9/24/2013 -11/18/2013)	20
Table 3-11: Comparison of Dissolved Oxygen (9/24/2013 -11/18/2013).....	22
Table 3-12 Soluble Reactive Phosphorus Removal for each Media (4/1/2013 – 11/18/2013)	25
Table 3-13 Total Phosphorus Removal for each Media (4/1/2013 – 11/18/2013)	25
Table 3-14 DOC (9/24/2013 -11/18/2013)	26
Table 3-15 Turbidity (4/1/2013 -11/18/2013).....	27
Table 3-16 Total Suspended Solids (9/24/2013 -11/18/2013).....	28
Table 3-17 pH (4/1/2013 -11/18/2013).....	30
Table 3-18 Alkalinity (4/1/2013 – 11/18/2013).....	31
Table 3-19 Temperature (4/1/2013 -11/18/2013)	31
Table 3-20 Heterotrophic Plate Count (4/1/2013 -11/18/2013).....	32
Table 3-21 Total Coliform.....	33
Table 3-22 <i>E. Coli</i>	34
Table 3-23 Langmuir isotherm equation parameters	40
Table 3-24 Adsorption comparison per unit media at 1 mg/L as P for the 2-, 12-, and 24-hour test runs	43

Table 3-25 Freundlich isotherm equation parameters run 24- hour - 1 and 24-hour - 2 . 45

Table 3-26 Langmuir isotherm equation parameters run 24-hour - 1 and 24-hour - 2 46

Table 4-1 Literature Review of Sorption Media Used by Different Researchers to Treat Wastewater (Adapted from Chang *et al.*, 2010)..... 51

Table 4-2 Component of the Two BAM Mixtures by Volume Tested for Nutrient Removal. 55

Table 4-3 Hach Test Method used to Determine Ortho- and Total Phosphorus Concentrations..... 56

Table 4-4 Material Characterization of the Most Efficient BAM Nutrient Sorption Media 63

Table 4-5 BAM Nutrient Mix 3-1 Isotherm Results for 12-hour contact time..... 65

Table 4-6 BAM Nutrient Mix 3-2 Isotherm Results for 12 hour contact time 65

Table 4-7 Langmuir isotherm for adsorption of phosphorus chemical species..... 68

Table 4-8 Freundlich isotherm for adsorption of phosphorus chemical species 69

Table 4-9 Isotherm data for BAM Nutrient mix 3-1 with varying contact time..... 69

Table 4-10 Isotherm data for BAM Nutrient mix 3-2 with varying contact time..... 70

Table 4-11 Langmuir isotherm data for BAM Nutrient mix 3-2 at varying residence times 73

Table 4-12 Freundlich isotherm data for BAM Nutrient mix 3-2 at varying residence times 73

Table 4-13 Average orthophosphate absorption equilibrium uptake, q ($\mu\text{g}\cdot\text{g}^{-1}$), for varying residence times and influent concentrations as determined from the isotherm studies..... 73

Table 4-14 Thomas model equation for orthophosphate adsorption on abiotic nutrient adsorption media 79

Table 5-1 Methods used to analyze concentrations of each chemical..... 93

Table 5-2 Parameters of the Thomas Model derived from the plot of $\ln(C_0/C_e - 1)$ vs. time 94

Table 5-3 Concentrations of Aluminum, Calcium, Iron, and Magnesium in Influent Pond Water 98

Table 5-4 Results of Batch Reactions Conducted After Running the Column for 10, 17, and 24 Days..... 100

Table 6-1 Off-Line Filter Effectiveness based on Concentration..... 121

Table 6-2 Off-Line Sorption Filter Water Quality Data 122

Table 6-3 On-Line Effectiveness before Exhaustion using 0.8 CY of Media..... 123

Table 6-4 On-Line System Performance Data for 0.8 CY of Media after Exhaustion.. 124

Table 6-5 On-Line Filter Effectiveness after exhaustion using 0.8 CY of Media..... 125
Table 7-1 Removal Percentages for Total Nitrogen and Total Phosphorus 128

CHAPTER 1: INTRODUCTION

1.1 BACKGROUND

The building of transportation facilities can be challenging in all types of watershed conditions. Finding a solution that meets multiple criteria is especially difficult in the ultra-urban environment. First, limited aboveground space in the ultra-urban environments complicates the construction of stormwater facilities that implement best management practices (BMP). Stormwater facilities located in these ultra-urban areas can be difficult and costly to construct. It is also difficult to find retrofit options. The following issues further complicate BMP use because of a need to 1) remove pollution from intensively used watersheds, 2) reduce peak flows, 3) maintain traffic, and 4) work around utility conflicts. In addition, ultra-urban environments are typically much more of challenging in terms of meeting receiving water quality conditions. Consequently, FDOT potentially faces costly and challenging solutions when seeking to reduce pollution from stormwater runoff in ultra-urban environments.

Based on the findings of this research project, researchers found that filtration media placed underground, or in or adjacent to transportation systems as part of stormwater retention facilities, can be a viable solution to reducing pollution in ultra-urban environments. The popular locations for the placement of filtration media are underground beneath some type of a vault or pipe. The filter media must have properties to enhance removal of a particular pollutant while performing with minimum maintenance. Used to remove pollutants in stormwater are several different types of stormwater facilities. As an example of a stormwater facility, filter media placed in on-line or off-line locations can strain particulates out of stormwater. Dissolved

pollutants can be capture by chemical precipitation treatment if sorption processes in the media do not remove them. In addition, pollutants can degrade naturally over time through biological means.

1.2 OBJECTIVES

The objectives of this research project were to document removal effectiveness. Used were laboratory and field demonstrations to document removal effectiveness. Designed were laboratory experiments to identify effective methods to remove nitrogen and phosphorus compounds. Performed were field demonstrations to determine the operation and effectiveness of sorption filter media over time.

1.2.1 Questions for Laboratory Investigations

- A. What are the mechanisms and predicted effectiveness for nitrogen and phosphorus removal in different media mixes?
- B. What operational conditions would result in improved removal of nitrogen and phosphorus by the media mixes?
- C. What is the life expectancy of the media mixes?

1.2.2 Questions for Field Demonstrations Using Underground Applications

- A. For an on-line filter, what is the expected performance in terms of nitrogen and phosphorus removal?
- B. For an off-line filter, what is the expected performance in terms of nitrogen and phosphorus removal?

1.3 LIMITATIONS

Florida climate conditions affected all field demonstrations. These conditions reflect a humid environment with average annual rainfall of about 50 inches per year. In addition, the average number of storm events per year is about 120 with about 60% of the events within 4 months of the year.

CHAPTER 2: PAST WORK WITH ULTRA-URBAN ENVIRONMENTS

2.1 A DEFINITION OF ULTRA-URBAN ENVIRONMENTS

Where there are adequate space and elevation differences, retrofitting highways with stormwater treatment Best Management Practices (BMPs) is relatively straightforward. However, initial construction and/or retrofit of stormwater facilities located in dense urban areas can be particularly costly and difficult due to space limitation, high pollutant loadings, high peak flows, traffic management, and utility conflicts. In addition, regulatory requirements may limit the solution for water quality and erosion control issues. Consequently, FDOT potentially faces costly and challenging solutions to pollutant reduction in ultra-urban environments.

The first use of the term ultra-urban is most likely by city staff in Alexandria, Virginia (Shoemaker et al., 2002). In an ultra-urban environment, the use of traditional treatment BMPs such as detention ponds, retention basins and swales is constrained by the lack of available surface area. Thus, the term “ultra-urban BMP” is associated with the inability to use BMPs regardless of their value.

2.2 WATER QUALITY PARAMETERS OF CONCERN

Phosphorus and nitrogen nutrient impairment is referenced in Section 303(d), 1998, 9List Fact Sheet for Florida, by the U.S. EPA) as the most common surface water body impairment in Florida. Phosphorus and nitrogen are necessary components for plants to convert sunlight into usable energy and essential for plant growth and reproduction. For example, excessive amount of phosphates in the inorganic form can result in excessive plant growth and eutrophication. This progression can reduce oxygen for aquatic organisms and increase organic matter

decomposition, which may restrain a healthy aquatic ecosystem. Because of this harmful cycle, algal blooms can gradually cover the entire pond surface, blocking sunlight penetration into the water column, leading to further ecological degradation (Jeffrey, 1998) and raising human health concerns. One of these human health issues involves certain algae species linked to eutrophication have affected the taste and odor of drinking water. High nitrate levels can lead to health problems. The industry recognized other consequences of trihalomethanes and chlorinated byproducts because of chlorinating with increased organics in the water due to eutrophication (Palmstrom, 1988).

The geology and land use of a watershed determines the nutrient input of the water body. Sources of excessive phosphates and nitrogen compounds are typically from fertilizer runoff. However, there may be surface waters wherein lower concentrations or loading rates produce high eutrophic and situations were higher concentrations do not cause nuisance algal spikes because eutrophication is variable and biologically dependent.

Research has focused on the understanding, regulation, and mitigation of phosphorus contamination of freshwater bodies because eutrophication is problematic worldwide. Although, no national criterion or regulations for phosphorus concentrations exist, the EPA has suggested critical loading levels for ponds (EPA, 1986). In larger surface waters, such as lakes, wetlands and streams in the U.S., the Clean Water Act (CWA) and the subsequent National Pollutant Discharge Elimination (NPDES) permits addresses the concentrations of phosphorus. The CWA requires that all states implement guidelines or water quality standards to regulate pollutant mass loading of stormwater prior to its discharge into receiving water bodies. Target concentrations for these water quality standards are set to protect the public's health and welfare, enhance the quality of the water, and serve the purposes of the CWA. Consequences of violating these

phosphorus standards or total maximum daily loads (TMDL) for a water body may lead to the impairment of its beneficial uses such as drinking water, cold-water fisheries, industrial water supply, recreation, and agricultural water supply.

2.3 MEDIA FILTERS

Media filters use select materials to remove particulate and dissolved pollution. When using a sorption media in the filter, expected is additional dissolved pollution removal. Media filters are different from retention or infiltration basins because the discharge from the media filter flows to surface outfalls. Designed are media filtration systems with little or no vegetation, while rain gardens, retention basins, and bio-retention areas typically have plants.

Typical components of a media filter are collection and distribution structures, pretreatment areas to remove gross solids, media filtration beds, effluent collection systems such as underdrains or up-flow channels, and discharge structures to surface outfalls. A certain size particle is usually the basis for the design of a filter. With this design, removed is an associated amount of dissolved material. Media filters are very suitable and applicable to ultra-urban retrofit applications because of the capability to remove significant levels of sediments, particulate-bound pollutants (metals, phosphorus) and organics (oil and grease). Media filter designs are amenable to ultra-urban constraints such as linear configurations and underground installations.

The location of a media filter relative to the transport pipe can be either off-line or on-line. Both designs must consider a provision for bypass of water when the flow is in excess of the treatment rate. Head loss must be available to attain a specified treatment rate. Typically,

the design rate of filtration are greater than or equal to 0.25 inches/hour because of cost and space (NCHRP, 2012).

The three categories for media filtration classifications are:

- Sand filter systems,
- Mixed media systems, and
- Engineered media systems,

Sorption-based media is a distinction in design and is part of a mixed media, from which dissolved pollutant removal is expected. Another distinction in design is the direction of flow, either a down-flow or an up-flow design. The down-flow is more common. Cleaning occurs more often with a down flow filter because of a build-up of solids on the filter surface, while cleaning is less often with the up-flow filter. Thus, up-flow filters are favored more often when placed underground. A pump suction-type evacuator is usually used for un-blocking a filter. The same equipment cleans debris and solids from catch basins and sewer lines. In front of a filter, a settling system minimizes solids and debris on the filter. The sedimentation process of the settling system removes most heavy solids, debris and floating materials, and reduces the maintenance needed to keep the filter operational.

2.3.1 Sand Media Systems

A sand filter is composed of graded sand and typically follows some type of sedimentation and debris separation system. The sand filter, usually two feet deep, removes

most particulates of a certain size. Locally available sandy media are preferred but some designs specify the sand particle-size distribution. A summary of early designs and performance is available in a government fact sheet (EPA, 2008). Normally, the sand particle-size distribution is not difficult to achieve. Example areas where sand filters are used, regulated and recommended for use are California (Caltrans, 2004), Austin Texas (2012), Massachusetts (Mass Highway, 2004) and Delaware (www.deldot.gov).

2.3.2 Mixed Media Systems

As the name implies, there are at least two different types of media that when used together achieve specified pollutant removal effectiveness. Media mixtures that are effective for removing a wide range of pollutant types are sand/clay with other additions (Woelkers et al., 2006), and expanded clay with other media (Ryan et al., 2009, Hardin et al., 2012). Some mixes target specific pollutants, such as used by the Washington State DOT whose mix targets dissolved metals (WSDOT, 2008a), and media mixes that target phosphorus (Ma et al., 2009), nitrate (Kim et al., 2003), phosphorus and nitrogen (O'Reilly et al., 2012), organics (Milesi et al., 2006), and metals and dioxins (Pitt and Clark, 2010). Thus, a wide selection of media mixtures are used for media filtration systems (Chang et al., 2010).

2.3.3 Engineered Media Systems

Engineered media filters are a special case of mixed media filters using natural sorption media to treat stormwater, wastewater, groundwater, landfill leachate, and sources of drinking water for nutrient removal via physicochemical and microbiological processes (Chang et al., 2010). The media may include, but are not limited to, sawdust, peat, compost, zeolite, wheat straw, newspaper, sand, limestone, expanded clay, wood chips, wood fibers, mulch, glass, ash,

pumice, bentonite, tire crumb, expanded shale, oyster shell, and soy meal hull (Hossain et al., 2010).

A unique recipe of sorption media (**BOLD & GOLD™**) was applied to support a floating wetland study, which was effective in reducing nitrogen (up to 47%) and phosphorus (up to 87%) from stormwater found in wet detention ponds. The media was not exhausted or saturated within a three-year period. More media would extend the life expectancy, and thus frequent replacement is not needed (Wanielista, et.al, 2012). One mix of **BOLD & GOLD™** (B&G) has an effective size of 0.150 mm. Each mix will have blends for particular pollutant removal objectives and life expectancy.

There are blends of sorption media on the market that will accomplish removal of dissolved pollution. Research needs to determine the life expectancy of the media removal mechanism. A biological removal mechanism that does not destroy the organisms is the most preferable mechanism because of the long life expectancy. Such biological removal media are Biosorption Activated Media (BAM). However, all pollutants cannot be removed effectively by biological means and thus, whatever mechanism used for the removal of dissolved pollution has to be documented to determine life expectancy of the removal mechanism.

CHAPTER 3: BASIC REMOVAL MECHANISMS

3.2 EXPERIMENTAL DESIGN: BAM COMPOSITIONS

The experimental design analyzed three types of BAM mixes, which are composed of fine expanded clay, 3/8-inch expanded clay, automobile tire crumb, limestone, and AASHTO (American Association of State Highway and Transportation Officials) classification A-3 sand and A-2-4 clayey sand. Automobile tires are generally composed of 27% to 33% carbon black by mass, which functions like activated carbon (Wanielista, Baldassari et al. 2008). Activated carbon is ideal for adsorption because of its large surface area to mass ratio, and is very effective in removing large organic molecules and non-polar compounds (Inglezakis and Pouloupoulos 2006). Furthermore, clay and limestone readily remove phosphorus via adsorption and precipitation, respectively. Table 3-1 presents the compositions of the media used in the experimentation.

Table 3-1 BAM Compositions

BAM mixtures	Permeability constant (in/hr.)	Fine Expanded Clay	3/8 inch Expanded Clay	Tire Crumb	A-3 sand	A-2-4 silty sand	Limestone Screenings
1	475.25	55%	20%	25%	0%	0%	0%
2	6.733	0%	25%	0%	50%	25%	0%
3	12.86	15%	0%	15%	50%	0%	20%

3.3 EXPERIMENTAL DESIGN: COLUMN SYSTEMS AND ANALYSIS

3.3.1 Column Set-Up

The bench-scale experiment consisted of nine columns divided into three sets of three columns each. All the columns had an internal diameter of 4 inches. The media occupied two feet of each column. For identification of the columns, each column had a number and letter designation, of which the number designates the type of media in the column (see **Table 3-1**), and the letter designates the column type (see Table 3-2). The A and B columns were the controls and the C columns received a continuous exposure of 10 mg/L of 2-Imidazolidinethione, a nitrification inhibitor. The A and B columns are identical to each other for each media type. For example, a column designated as A1 means control column and mixture 1. Comparisons of Columns A and B to Column C revealed if the ammonia and nitrogen transformations and/or removals were mostly biological or not.

Table 3-2 Column Types

Column Type	
A	Control
B	Control
C	Nitrification Inhibitor

3.3.2 Column Operations

The column operations simulated 2- and 24-hour “storm events”. There were three two-hour storm events per week and one 24-hour, lower intensity, storm event per week. Based off the dimension for each (a diameter of 4 inches and a height of 24 inches), the total volume was 302 in³ and cross-sectional area of 12.57 inches. The governing mechanism for phosphorus removal was adsorption that began occurring immediately. However, it took months for nitrification to reach its maximum or “steady-state” value. Consequently, the analysis of phosphorus data started early from 4/1/2013 until 11/18/2013, while nitrogen data analysis was from 9/24/2013 to 11/18/2013. Thus, there were separate Empty-Bed Contact Times (EBCTs) calculations for phosphorus and nitrogen removal. Table 3-3 and Table 3-4 present the average EBCT and hydraulic loading rates for the two-hour and 24-hour storm events for phosphorus removal, respectively.

Table 3-3 Phosphorus Species Removal - Average EBCT & Hydraulic Loading Rates for Two-Hour Tests (4/1/2013 – 11/18/2013) with EBCT = 22.9 minutes

Column Media #	Column Type	Empty bed Contact time (minutes)	Hydraulic Load per unit volume of media "1/hour" (in ³ water / hour) / (in ³ of media)	Hydraulic Load per cross -sectional area (aka the flux) "in/hour" (in ³ water / hour) / (in ² of cross section)
1	A	24.2	2.48	59.55
1	B	22.4	2.68	64.38
1	C	22.3	2.69	64.62
2	A	23.5	2.55	61.18
2	B	25.8	2.33	55.91
2	C	22.3	2.69	64.61
3	A	22.1	2.72	65.21
3	B	21.5	2.79	66.91
3	C	22.1	2.71	65.05

Table 3-4 Phosphorus Species Removal - Average EBCT & Hydraulic Loading Rates for 24-Hour Tests (4/1/2013 – 11/18/2013) with Average EBCT=230 minutes

Column Media #	Column Type	Empty bed Contact time (minutes)	Hydraulic Load per unit volume of media "1/hour" (in ³ water / hour) / (in ³ of media)	Hydraulic Load per cross-sectional area (aka the flux) "in/hour" (in ³ water / hour) / (in ² of cross section)
1	A	283.2	0.21	5.08
1	B	212.6	0.28	6.77
1	C	207.7	0.29	6.93
2	A	251.6	0.24	5.72
2	B	248.4	0.24	5.80
2	C	265.7	0.23	5.42
3	A	197.8	0.30	7.28
3	B	198.6	0.30	7.25
3	C	202.8	0.30	7.10

Table 3-5 and Table 3-6 show the average EBCT and hydraulic loading rates for the two-hour and 24-hour storm events for nitrogen, respectively. The data show that the hydraulic conditions in both periods were virtually identical.

Table 3-5 Nitrogen Species Removal - Average EBCT & Hydraulic Loading Rates for Two-Hour Tests (9/24/2013 – 11/18/2013) with EBCT = 21.9 minutes

Column Media #	Column Type	Empty bed Contact time (minutes)	Hydraulic Load per unit volume of media "1/hour" [(in ³ water / hour) / [in ³ of media]	Hydraulic Load per cross-sectional area (aka the flux) "in/hour" (in ³ water / hour) / (in ² of cross section)
1	A	22.0	2.73	65.54
1	B	21.4	2.81	67.38
1	C	21.3	2.81	67.54
2	A	21.3	2.81	67.51
2	B	23.1	2.60	62.40
2	C	21.9	2.74	65.76
3	A	22.1	2.72	65.19
3	B	21.2	2.82	67.78
3	C	22.6	2.65	63.61

Table 3-6 Nitrogen Species Removal - Average EBCT & Hydraulic Loading Rates for 24-Hour Tests (9/24/2013 – 11/18/2013) with EBCT = 234.8 minutes

Column Media #	Column Type	Empty bed Contact time (minutes)	Hydraulic Load per unit volume of media "1/hour" (in ³ water / hour) / (in ³ of media)	Hydraulic Load per cross-sectional area (aka the flux) "in/hour" (in ³ water / hour) / (in ² of cross section)
1	A	307.2	0.20	4.69
1	B	185.5	0.32	7.76
1	C	179.6	0.33	8.02
2	A	271.3	0.22	5.31
2	B	277.3	0.22	5.19
2	C	288.9	0.21	4.98
3	A	197.6	0.30	7.29
3	B	204.1	0.29	7.05
3	C	201.9	0.30	7.13

3.4 SAMPLING AND MEASUREMENTS

Nitrogen and phosphorus were two of the key parameters studied. Nitrogen and phosphorus forms include soluble reactive phosphorus (SRP, approximately equal to ortho-phosphorus), total phosphorus, combined nitrate & nitrite (NO_x), organic nitrogen, and ammonia. The stormwater used in this study was analyzed for nitrate and nitrite and it was determined that the dominant form was consistently nitrate. As a result, the analysis was on the combined nitrite and nitrate (NO_x) rather than separate nitrite and nitrate. *Environmental Research & Design (ERD)*, a NELAC (National Environmental Laboratory Accreditation Conference) certified laboratory, performed analysis for SRP, total phosphorus, NO_x, total nitrogen, and ammonia. Table 3-7 presents the test methods utilized by ERD for nitrogen and phosphorus forms testing. Nutrient sample collections were from the influent barrels and the effluent collection tubs.

Other parameters measured in the Environmental Engineering/Stormwater Academy laboratories at UCF included dissolved organic carbon (DOC), heterotrophic plate counts (HPC), Total Coliform (TC) and *E. Coli*, total suspended solids (TSS), turbidity and dissolved oxygen (DO). All testing methods were in accordance to Standard Methods. Personnel from the UCF Molecular and Microbiology Department developed and performed the qPCR testing on the nutrient samples. Turbidity, TSS, DOC, and bacteria samples collections were from the influent barrels and the effluent collection tubs. However, measurements for the DO readings were by insertion of the probe into the influent barrels for influent samples, and into the water at the top of the columns, and not in the collection tubs, for effluent samples.

Table 3-7 Chemical analysis methods run at ERD (Oviedo, Florida)

Parameter	Test Methods
SRP	EPA 365.1
	SM 21 4500-P F
TN	SM 21 4500-N C
NH ₃	EPA 350.1
	SM 21 4500-NH3 G
TP	EPA 3565.1
	SM 4500-P F & SM 4500-P FB.5
NO _x	EPA 353.2
	SM 4500-NO ₃ F

3.5 RESULTS

The focus of this analysis was on the comparison of nutrient removal by the three different media mixtures. The three columns of A, B and C each media mix were identical, the C column was dosed with nitrification inhibitor. All three types of media took between two to five months to reach steady state with respect to nitrogen transformations (i.e. nitrification and denitrification). Media mix 1 reached steady state for nitrogen transformation in a shorter period

than the other two media mixes. The gradual increase in nitrification over the first months of column operation were because of the slow growth rate of nitrifying bacteria and the pristine conditions of the media mixes at the start of the operations. Thus, the data set used for total phosphorus and SRP analysis were from between 4/1/2013 and 11/18/2013, and the data for nitrogen species analysis were from 9/24/2013 through 11/18/2013.

3.5.1 Nitrogen

The study considered two experimental approaches conducted concurrently to determine if biological or abiotic (e.g. sorption, ion exchange, etc.) phenomena accounted for all the nitrogen (N) removal and transformations observed in the columns. First, the C columns received a nitrification inhibitor, 2-Imidazolidinethione at a concentration of 10 mg/L for the evaluation of the partial or total inhibition of nitrogen transformations (i.e. ammonia oxidation to NO_x and subsequent denitrification/N removal). Note that other than the nitrification inhibitor, the C column is identical to the A and B columns for each media. Presented in the following sections on nitrogen are the discussion on nitrification inhibition in the C columns for the two-hour and 24-hour storm events. Second, the study conducted isotherm experiments to determine if there were significant adsorption of ammonia or nitrate by the media in the column. Presented in Section 3.5.11 is the discussion on the isotherm data.

3.5.1.1 Nitrogen: Two-Hour Storm Events

Presented in Appendix A, Table A-1 are the relevant nitrogen data for the two-hour storm events, and Table 3-8 is an abridged version of the Table A-1. Nitrogen mass balance calculations showed that Media mix 1 achieved a higher percent nitrification and a higher

denitrification/TN removal than the other media (see the two far right columns of Table 3-8).

Details of the nitrogen mass balance equations are in Appendix A.

Table 3-8 Nitrogen Transformation and Removal: Two-Hour Storm Event; Average EBCT of 21.9 minutes (9/24/2013 – 11/18/2013)

Column Media #	Column Type	Average of Effluent NO _x (mg/L as N)	Average of Effluent NH ₃ (mg/L as N)	% of available TN that was nitrified	% Removal of TN (i.e.% denitrification of influent TN)
1	A	0.370	0.355	41%	28%
1	B	0.392	0.385	40%	25%
1	C	0.219	0.641	11%	10%
2	A	0.468	0.447	35%	16%
2	B	0.437	0.456	29%	13%
2	C	0.254	0.696	4%	3%
3	A	0.516	0.355	41%	19%
3	B	0.417	0.433	37%	21%
3	C	0.171	0.776	4%	5%

Media mixes 1 and 3 achieved average nitrification of 41% and 39%, respectively, while Media 2 had 32% average nitrification. The much lower or negligible nitrification (and total nitrogen removal) observed in each media mixes of C columns confirmed the occurrence of nitrification. Figure 3-1 shows the percentage of total nitrogen removal for each of the media mixes. Media 2 mix had nitrification but the N removal was inferior to the other two media mixes. In addition, Figure A-2 in Appendix A shows the performance for each of the individual A and B columns for each material.

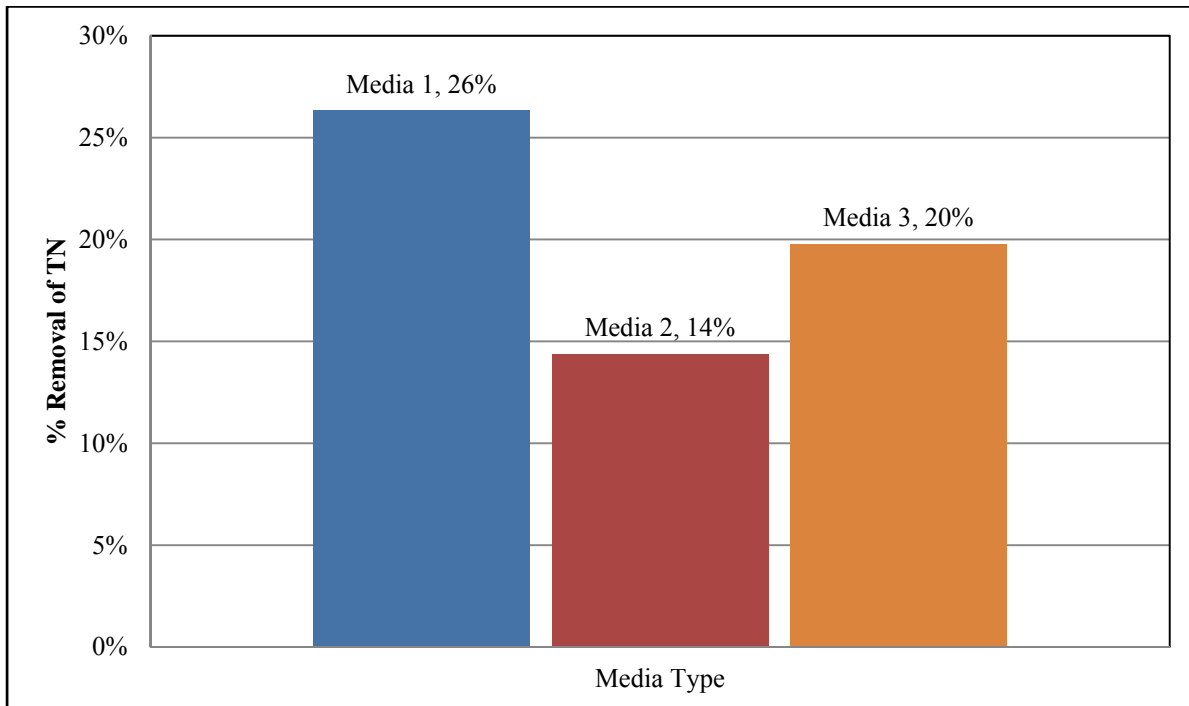

Figure 3-1 Percent Average Removal of TN for each Media Type – Two-Hour Event; Average EBCT of 21.9 minutes (9/24/2013 – 11/18/2013)

3.5.1.2 Nitrogen: 24-Hour Storm Events

Table A-2 on Appendix A presents the relevant nitrogen data for the 24-hour storm events, but Table 3-9 presents an abridged version of the Table A-2. Media mixes 1 and 2 achieved average nitrification of 42% and 47%, respectively, while Media mix 3 achieved 35% average nitrification. Media mix 1 had the highest total nitrogen removal of the three media mixes (Figure 3-2), and had a much lower effluent NO_x concentration at an average of 0.0815 mg/L as N. In addition, Media mix 2 had less total nitrogen removal compared to Media mixes 1 and 3. The C columns showed low or negligible nitrification and denitrification, which is indicative of the biological nature of the N transformations and removal.

Table 3-9 Nitrogen Transformation and Removal: 24-Hour Storm Event; Average EBCT of 234.8 minutes (9/24/2013 – 11/18/2013)

Column Media #	Column Type	Average of Effluent NO _x (mg/L as N)	Average of Effluent NH ₃ (mg/L as N)	% of available TN that was nitrified	% Removal of TN (i.e.% denitrification of influent TN)
1	A	0.059	0.291	35%	44%
1	B	0.104	0.184	49%	52%
1	C	0.013	0.740	-7%	0%
2	A	0.651	0.155	49%	16%
2	B	0.467	0.264	45%	26%
2	C	0.133	0.821	-3%	0%
3	A	0.276	0.229	28%	25%
3	B	0.177	0.250	41%	42%
3	C	0.028	0.824	5%	10%

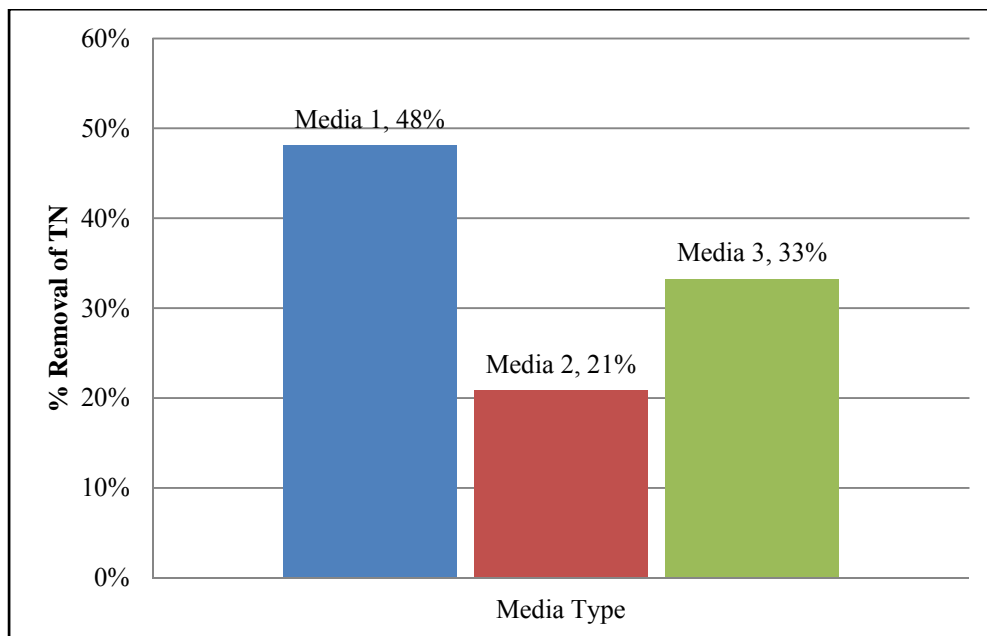

Figure 3-2 Percent Average Removal of TN for each Media Type – 24-Hour Event; Average EBCT of 234.8 minutes (9/24/2013 – 11/18/2013)

3.5.1.3 Nitrogen: Comparison of Two-Hour & 24-Hour Storm Events

Table 3-10 presents the comparison between the two-hour and 24-hour storm events. There was a consistent change in the percentage of nitrification in all media mixes evaluated for both storm events. Nitrification in Media mix 2 increased but decreased in Media mix 3.

Table 3-10 Average Nitrogen Transformation and Removal for each Media: Comparison of Two-Hour & 24-Hour Events (9/24/2013 -11/18/2013)

Media	% of available TN that was nitrified		% Removal of TN (Denitrification)	
	Two-Hour: avg. EBCT = 21.9 min	24-Hour: avg. EBCT = 234.8 min	Two-Hour: avg. EBCT = 21.9 min	24-Hour: avg. EBCT = 234.8 min
1	41%	42%	26%	48%
2	32%	47%	14%	21%
3	39%	35%	20%	33%

Table 3-11 showed that the 24-hour storm event test had lower effluent dissolved oxygen concentrations were lower for all the columns than the two-hour storm event tests. Apparently, at the lower loading rate there was enough contact time to lower the dissolved oxygen concentration, which facilitated anoxic conditions within parts of the column biofilm. This anoxic condition would account for the observed increase in denitrification/TN removal during the 24-hour events (Table 3-10). The EBCT of the 24-hour storm event was approximately 10.5 times that of the two-hour storm event, and this may have resulted in the significantly greater denitrification for all the media during the 24-hour event.

Table 3-11: Comparison of Dissolved Oxygen (9/24/2013 -11/18/2013)

Approximate Flow Duration (hours)	Column #	Column Type	Influent DO (mg O ₂ / L)	Effluent DO (mg O ₂ / L)	DO Consumed (mg O ₂ / L)
2	1	A	5.3	2.5	2.8
2	1	B	5.3	2.1	3.2
2	1	C	6.0	3.9	2.1
2	2	A	5.3	3.1	2.3
2	2	B	5.3	3.3	2.0
2	2	C	6.0	5.1	0.8
2	3	A	5.3	2.1	3.2
2	3	B	5.3	2.2	3.1
2	3	C	6.0	3.8	2.2
24	1	A	5.5	1.3	4.3
24	1	B	5.5	1.6	4.0
24	1	C	5.8	1.9	4.0
24	2	A	5.5	1.1	4.5
24	2	B	5.5	1.0	4.5
24	2	C	5.8	3.2	2.6
24	3	A	5.5	0.9	4.6
24	3	B	5.5	1.0	4.5
24	3	C	5.8	1.0	4.8

Figure 3-3 and Figure 3-4 present scatter plots showing the relationship between EBCT or hydraulic loading rate and total nitrogen removal efficiency. Note that the data points presented in each plot were from averaging the EBCT, hydraulic loading rate and percentage removal of TN values in each media mixes in Column A and B. The increase in EBCT and decrease of the hydraulic loading significantly improved TN removal for Media 1 and 3. Media 2 did not show as much of an improvement in TN removal and was less sensitive to changes in hydraulic conditions than the other two media mixes with a consistently lower TN removal under all conditions.

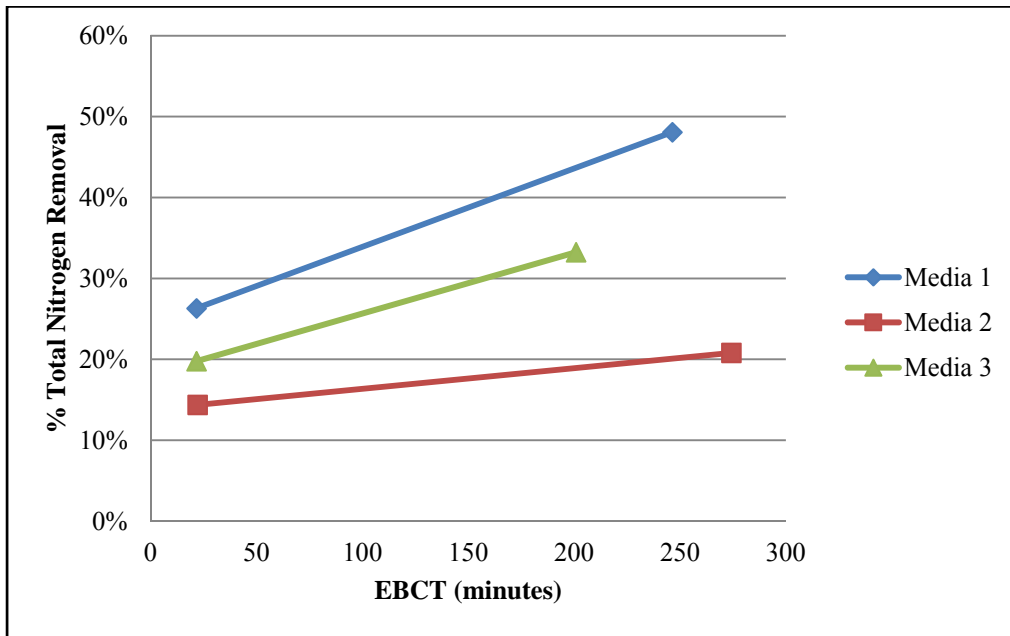

Figure 3-3 EBCT versus Total Nitrogen Removal Efficiency

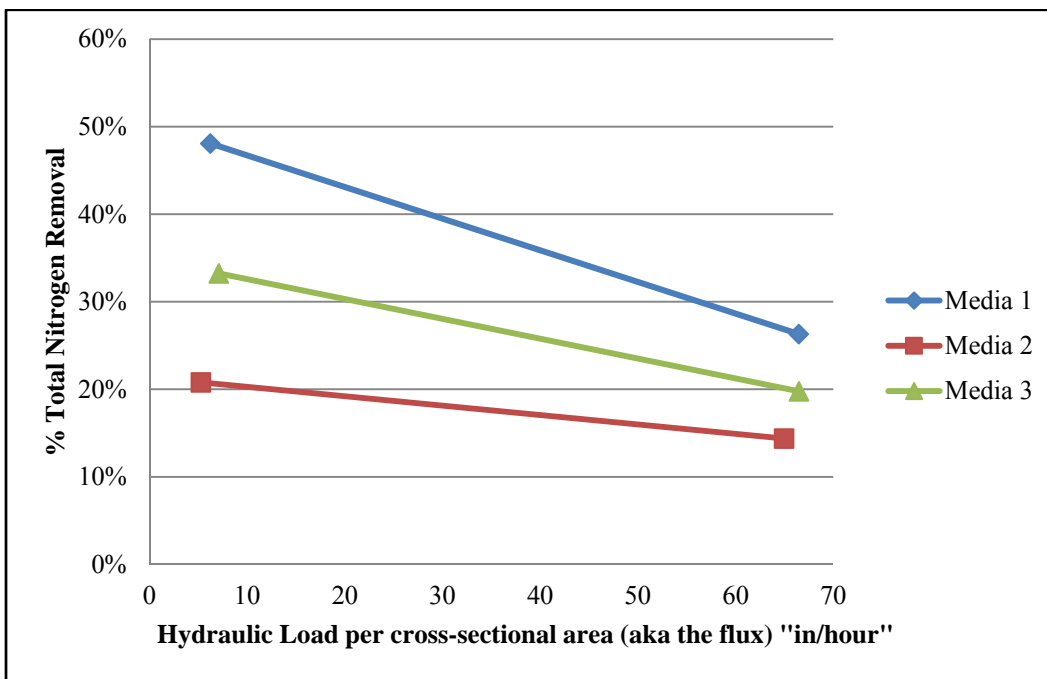

Figure 3-4 Hydraulic Loading versus Total Nitrogen Removal Efficiency

3.5.2 Dissolved Oxygen

As shown in Table 3-11, the consumption of dissolved oxygen (DO) indicates how much aerobic biological activity is occurring in the columns (i.e. both carbonaceous and nitrogenous oxygen demand combined). The longer contact time of the 24-hour storm events resulted in higher DO consumption (both as concentration and on a mass flux basis) than those observed for the two-hour storm events because the total flow volume in a 24-hour storm event was 1892 liters on average versus 1583 liters for a two-hour storm event (Table 3-11). The lower the bulk DO the more likely that oxygen would be limited in parts of the depth of the biofilms within the columns. Recall that the C Columns received nitrification inhibitor, thus one would expect the columns to have lower DO consumptions because nitrification requires the consumption of DO. This is true for all of the columns for the two-hour storm events. However, the DO consumption for the C Columns during the 24-hour events do not follow the same trend, possibly because the influent with the nitrification inhibitor in it had a higher initial DO (the C columns had higher effluent DOs for two of the three columns). Another possible explanation is that denitrification during the 24-hour storm events reduced the amount of carbonaceous oxygen required for biodegradation of organic matter in the A and B columns.

3.5.3 Phosphorus

3.5.3.1 Soluble Reactive Phosphorus

Table 3-12 presents the Soluble Reactive Phosphorus (SRP) data, which indicated that Media mix 1 performed better than the other media in terms of SRP removal for both the two-hour and 24-hour storm events. Media mix 1 consistently removed over 50% of the SRP in both storm event tests. In addition, the longer contact time of the 24-hour storm event increased SRP removal efficiency for Media mixes 1 and 2 but not for Media 3 (see Table A-4 in Appendix A).

Table 3-12 Soluble Reactive Phosphorus Removal for each Media (4/1/2013 – 11/18/2013)

Approximate Flow Duration (hours)	Column Media #	Average Influent SRP (mg/L as P)	Average Effluent SRP (mg/L as P)	Δ SRP (mg/L as P)	SRP % Removal
2	1	0.189	0.081	-0.108	57%
2	2	0.188	0.123	-0.064	34%
2	3	0.188	0.109	-0.079	42%
24	1	0.177	0.061	-0.117	66%
24	2	0.177	0.112	-0.065	37%
24	3	0.177	0.136	-0.041	23%

3.5.3.2 Total Phosphorus

Table 3-13 presents the total phosphorus data per column. Just as with SRP, Media mix 1 performed the best for both the two- and 24-hour storm events for total phosphorus removal. Overall, the total phosphorus data is more variable than the SRP data and percentage removals were lower. The variability is probably because the effluent particulate concentrations may depend on non-steady state events such as sloughing of biofilm or suspension of fine material, which then exits the columns in the effluent.

Table 3-13 Total Phosphorus Removal for each Media (4/1/2013 – 11/18/2013)

Approximate Flow Duration (hours)	Column Media #	Average Influent TP (mg/L as P)	Average Effluent TP (mg/L as P)	Δ TP (mg/L as P)	TP % Removal
2	1	0.235	0.114	-0.121	52%
2	2	0.233	0.177	-0.056	24%
2	3	0.233	0.135	-0.098	42%
24	1	0.229	0.153	-0.076	33%
24	2	0.229	0.162	-0.067	29%
24	3	0.229	0.197	-0.033	14%

3.5.4 Dissolved Organic Carbon

Table 3-14 presents the Dissolved Organic Carbon (DOC) data for the columns. The DOC had many potential sources and sinks in the column systems and the DOC levels were

largely unaffected by the columns, especially in the 24-hour storm event tests. The two-hour storm event tests yielded data that was erratic, but there were no consistent trends and no columns showed a change in DOC greater than 20%. The data implies that much of the DOC was not readily biodegradable.

Table 3-14 DOC (9/24/2013 -11/18/2013)

Approximate Flow Duration (hours)	Column Type	Column Media #	Average of Influent DOC (mg C/L)	Average of Effluent DOC (mg C/L)	Δ in DOC (mg C/L)	% Removal of DOC
2	A	1	7.62	6.26	-1.36	18%
		2	7.62	7.20	-0.42	6%
		3	7.62	7.11	-0.51	7%
	B	1	7.62	7.75	0.13	-2%
		2	7.62	8.60	0.98	-13%
		3	7.62	9.15	1.53	-20%
24	A	1	7.80	7.80	0.00	0%
		2	7.80	7.51	-0.28	4%
		3	7.80	7.77	-0.03	0%
	B	1	7.80	7.39	-0.41	5%
		2	7.80	7.18	-0.62	8%
		3	7.80	7.63	-0.17	2%

3.5.5 Turbidity

Table 3-15 presents the average influent and effluent turbidities. Note that the turbidity decreased in 14 of 18 columns. Columns 2B and 2C in the two-hour tests had very high effluent turbidity. Media mix 2 contained AASHTO classification A-2-4 clayey sand, which is composed of fines, and the fines may be what caused the turbidity to increase. It is notable that the turbidity increase for Media mix 2 only occurred in the two-hour storm event tests, while the 24-hour storm event tests showed a decrease in turbidity for all the media mixes except in column 1C. The decreased turbidity was probably because of the lower flow rate associated with the 24-hour storm event time. The two-hour storm event tests had significantly higher up-flow

velocity (1.05 in/min) than the 24-hour storm event test (0.104 in/min) and this means that fines were more likely to be suspended in the two-hour storm event test.

Table 3-15 Turbidity (4/1/2013 -11/18/2013)

Approximate Flow Duration (hours)	Column Media #	Column Type	Average Influent Turbidity (NTU)	Average Effluent Turbidity (NTU)	% Removal of Turbidity
2	1	A	4.36	2.68	39%
		B	4.36	3.04	30%
		C	4.18	3.05	27%
	2	A	4.36	3.57	18%
		B	4.36	11.09	-155%
		C	4.11	20.83	-406%
	3	A	4.36	4.96	-14%
		B	4.36	2.34	46%
		C	4.11	3.22	22%
24	1	A	2.82	2.53	10%
		B	2.82	2.19	22%
		C	2.67	3.76	-41%
	2	A	2.82	1.44	49%
		B	2.82	2.20	22%
		C	2.67	1.83	31%
	3	A	2.82	2.10	25%
		B	2.82	1.53	46%
		C	2.76	1.58	43%

3.5.6 Total Suspended Solids

Table 3-16 shows the average influent and effluent total suspended solids (TSS). Note that with the exception of Columns 2A and 2B during the two-hour storm event tests, and column 3A for the 24-hour storm event tests, the TSS decreased. As discussed previously in the turbidity section, Media mix 2 contained AASHTO classification A-2-4 clayey sand which may be what caused the TSS (and turbidity) to increase in the Media mix 2 columns during the two-hour storm event tests.

Table 3-16 Total Suspended Solids (9/24/2013 -11/18/2013)

Approximate Flow Duration (hours)	Column Media #	Column Type	Average of UCF Analyzed: Influent TSS (mg/L)	Average of UCF Analyzed: Effluent TSS (mg/L)	% Removal
2	1	A	6.39	3.03	53%
		B	6.39	4.52	29%
	2	A	6.39	6.84	-7%
		B	6.39	6.48	-1%
	3	A	6.39	2.77	57%
		B	6.39	3.77	41%
24	1	A	2.91	0.90	69%
		B	2.91	1.67	42%
	2	A	2.91	1.85	36%
		B	2.91	0.40	86%
	3	A	2.91	3.53	-21%
		B	2.91	2.33	20%

3.1 OBJECTIVE

This Chapter present the information needed to evaluate the nitrogen and phosphorus removal capacities of BAM mixtures; and to determine if sorption is the only significant removal mechanism or if other mechanisms, such as microbiological assimilation or biotransformation (e.g. nitrification, denitrification) are significant. To determine how much of the transformations and/or removal are due to biological or non-biological activity, the study analyzed nitrogen transformations and removal. Described in the following sections is the experimental design to determine the fate of nitrogen and phosphorus and other water quality parameters.

3.5.7 pH

Table 3-17 showed that the pH data for Media mix 3, (had limestone in the mix), consistently elevated the influent pH (which was slightly below neutrality) more than the other two media mixes. The pH of Media mix 3 had greater increment for the 24-hour storm event

tests than the two-hour storm event tests and this was likely due to the longer contact time. The acidity or basicity of the media (pH) is an important parameter because it can have an effect on adsorption chemistry, precipitation, and biological kinetics. However, the pH measurements indicated chemical neutrality and should not significantly affect biological reactions or growth. The pH measurement was neither indicated alkalinity, which might cause chemical precipitation. The biggest difference in effluent pH measurements between columns was approximately 0.5 pH units and probably did not affect adsorption or measurably biological kinetics.

Table 3-17 pH (4/1/2013 -11/18/2013)

Approximate Flow Duration (hours)	Column Media #	Column Type	Average of Influent pH	Average of Effluent pH	Average difference in pH Δ pH
2	1	A	7.01	7.22	0.22
		B	7.01	7.23	0.24
		C	7.11	7.21	0.14
	2	A	7.01	7.25	0.25
		B	7.01	7.22	0.21
		C	7.11	7.32	0.24
	3	A	7.01	7.46	0.45
		B	7.01	7.41	0.40
		C	7.11	7.42	0.33
24	1	A	6.96	7.19	0.24
		B	6.96	7.22	0.26
		C	7.01	7.06	0.04
	2	A	6.96	7.10	0.14
		B	6.96	7.00	0.04
		C	7.01	7.23	0.22
	3	A	6.96	7.56	0.61
		B	6.96	7.49	0.53
		C	7.01	7.48	0.47

3.5.8 Alkalinity

Alkalinity data presented in Table 3-18 indicated that Media mix 3, which contains limestone, consistently increased alkalinity of the stormwater as it passed through the media. This corresponds to the fact that the pH of the stormwater that passed through Media mix 3 also increased (Table 3-17). Media mix 2 had the smallest change in alkalinity; which also corresponds to the pH data presented in the previous section (the stormwater treated with Media mix 2 experienced the smallest pH change).

Table 3-18 Alkalinity (4/1/2013 – 11/18/2013)

Approximate Flow Duration (hours)	Column Media #	Column Type	Average of Influent Alkalinity (mg/L as CaCO ₃)	Average of Effluent Alkalinity (mg/L as CaCO ₃)	Δ in Alkalinity (mg/L as CaCO ₃)
2	1	A	80.66	86.60	5.94
		B	79.46	80.94	1.48
		C	79.31	84.56	5.24
	2	A	80.66	76.63	-4.03
		B	80.66	79.55	-1.11
		C	79.31	80.93	1.61
	3	A	80.66	92.97	12.31
		B	80.66	92.37	11.71
		C	79.31	94.86	15.54
24	1	A	79.69	86.08	6.39
		B	79.69	85.85	6.16
		C	79.69	90.56	10.87
	2	A	79.69	80.78	1.09
		B	79.69	80.67	0.97
		C	79.69	81.36	1.67
	3	A	79.69	96.97	17.28
		B	79.69	104.28	24.59
		C	79.69	97.57	17.88

3.5.9 Temperature

The columns were located in a climate controlled (i.e. air-conditioned) room, and the temperature varied slightly (less than one degree centigrade) within the period during tests and data collection. Table 3-19 shows the average temperatures for the two-hour and 24-hour storm event tests, which are approximately equal.

Table 3-19 Temperature (4/1/2013 -11/18/2013)

Approximate Flow Duration (hours)	Average of Temperature °C
2	23.0
24	21.9

3.5.10 Bacteria

3.5.10.1 Heterotrophic Plate Count and Total Coliform & *E. Coli*

Table 3-20 presents the effluent heterotrophic plate counts (HPCs). The HPC effluent values are slightly higher than the influent values in all but two columns but the increase is small and in some cases negligible. In previous work at UCF by Zhao *et al.*, 2011, it was determined that the precision of the HPC test was about 0.3 log (a change of about 100% or a factor of 2). The largest change observed for the two-hour storm event test was from column 2A, which was an increase of 23.4% or 0.088 log. For the 24-hour storm event tests, column 3B had an increase of 0.45 log (280%), barely greater than the HPC method precision of 0.3 log or the HPC level shows a negligible increase in some columns.

Table 3-20 Heterotrophic Plate Count (4/1/2013 -11/18/2013)

Approximate Flow Duration (hours)	Column Media #	Column Type	Average of Influent HPC CFU/mL	Average of Effluent HPC CFU/mL	Change in HPC CFU/mL
2	1	A	4.65E+05	4.62E+05	-2.97E+03
		B	4.65E+05	3.81E+05	-8.39E+04
	2	A	4.65E+05	5.73E+05	1.09E+05
		B	4.65E+05	5.49E+05	8.41E+04
	3	A	4.65E+05	4.71E+05	6.55E+03
		B	4.65E+05	4.66E+05	9.29E+02
24	1	A	2.73E+05	7.45E+05	4.72E+05
		B	2.73E+05	5.15E+05	2.42E+05
	2	A	2.73E+05	5.17E+05	2.44E+05
		B	2.73E+05	5.25E+05	2.52E+05
	3	A	2.73E+05	4.61E+05	1.87E+05
		B	2.73E+05	7.65E+05	4.92E+05

However, the data for Total Coliforms (TC) in Table 3-21 and *E. coli* data in

Table 3-22 revealed that the bacterial population in the effluent was significantly different from that in the influent. In other words, it was likely that a significant fraction of the effluent bacteria originated from sloughed biofilm, while there was partial and significant removal of influent organisms in the filter. Effluent TC were consistently lower than the influent TC, and in the 24-hour storm event tests the decrease was more than an order of magnitude (greater than unit log) in most of the columns. In the two-hour storm event test, the decrease in the TC were much more modest – often by about a factor of two (0.3 log), although a significant fraction of columns showed decrease by a factor of three or more (i.e. 1C, 3A, 3B, 3C). The presence of *E. coli* were very low in both the influent and effluent samples. The value of 25 per 100 mL is near the method detection limit and *E. coli* was only detected in five of the 18 column effluents and was absent from the influent for the 24-hour storm event tests.

Table 3-21 Total Coliform

Approximate Flow Duration (hours)	Column Media #	Column Type	Average of Influent - Total Coliform: Most Probable Number per 100mL	Average of Effluent - Total Coliform: Most Probable Number per 100mL	Δ in Total Coliform: Most Probable Number per 100 mL
2	1	A	11570	6045	-5525
		B	11570	5373	-6197
		C	11660	2790	-8870
	2	A	11570	4080	-7490
		B	11570	9569	-2001
		C	11660	10763	-898
	3	A	11570	3708	-7862
		B	11570	1892	-9678
		C	10751	1748	-9003
24	1	A	3424	153	-3271
		B	3424	257	-3168
		C	3424	151	-3273
	2	A	3424	203	-3221
		B	3424	207	-3218
		C	3424	414	-3010
	3	A	3424	203	-3221
		B	3424	203	-3221

Approximate Flow Duration (hours)	Column Media #	Column Type	Average of Influent - Total Coliform: Most Probable Number per 100mL	Average of Effluent - Total Coliform: Most Probable Number per 100mL	Δ in Total Coliform: Most Probable Number per 100 mL
		C	3424	1034	-2391

Table 3-22 E. Coli

Approximate Flow Duration (hours)	Column Media #	Column Type	Average of Influent - E. Coli: Most Probable Number per 100mL	Average of Effluent - E. Coli: Most Probable Number per 100mL	Δ in E. Coli: Most Probable Number per 100 mL
2	1	A	51	25	-26
		B	51	33	-17
		C	25	33	8
	2	A	51	67	16
		B	51	0	-51
		C	25	0	-25
	3	A	51	0	-51
		B	51	0	-51
		C	33	0	-33
24	1	A	0	0	0
		B	0	0	0
		C	0	0	0
	2	A	0	0	0
		B	0	0	0
		C	0	50	50
	3	A	0	0	0
		B	0	0	0
		C	0	0	0

3.5.10.2 qPCR

The use of real-time quantitative PCR (qPCR) on-line at the UCF laboratory required the development and/or refinement of primers used in past studies, especially for the quantification of Anammox. The development of new external DNA standards for quantification were in collaboration with Integrated DNA Technologies using BLAST®, and maintained by the National Center for Biotechnology Information. The next step in the use of the qPCR

methodology for the analysis of samples was the development of DNA extraction methodology. However, the development of the qPCR was not complete at sampling to conduct real-time analysis. Thus, samples taken within the period for the development of the qPCR methodology were stored at -80°C for preservation of samples. From stored samples, extracted were DNA and then qPCR analysis performed for ammonia oxidizers, nitrite oxidizers, denitrifier, and Anammox bacteria.

3.5.11 Equilibrium Isotherm (i.e. Adsorption) Experiments

Adsorption estimates using equilibrium isotherms started once it became apparent that Media mix 1 had superior removals of N and P in the column tests. The performance of equilibrium isotherms was either using a constant concentration of the sorbate and a fixed quantity of media (the initial two-hour and 12-hour equilibration isotherms) or a fixed amount of media (50 grams) and a varying concentration of the sorbate (the more definitive 24-hour equilibration isotherms). Phosphorus was the sorbate for all tests, but a few tests showed that ammonia and nitrate adsorbate relative to the observed biological N transformations was not significant. The isotherm data testing used the 500 mL Erlenmeyer flasks (conical flasks). In each flask was 300 mL of unfiltered pond water and a phosphorus spike. The spike volume was negligible because the concentration of the standard solution was 100 mg/L as PO_4^{2-} (32.7 mg/L as P) but the typical concentration of the experiment was around 1 mg/L as P. The standard solution had 0.1433g/L of monopotassium phosphate salt (KH_2PO_4).

Test preparation for Media mix 1 involved the soaking of media sample in distilled water overnight and then drying in a 105°C oven overnight to get rid of any phosphorus or nitrogen forms that might leach out during the isotherm experiments. Next, for the two-hour and 12-hour

experiments, different masses of Media mix 1 was inserted into each 500 mL flask along with the 300 mL of spiked, unfiltered, pond water. Typical amounts of the sample media were 10, 50, and 100 grams (actual amounts varied from one to 200 grams, but some amounts of media at the high and low end of the range did not yield good data).

In the 24-hour experiments, all flasks received 50 grams of media and P concentrations of 0.5, 1.0, 5.0, 10.0, and 20.0 mg/L as P. The flasks were then covered with parafilm, to minimize contamination or loss of liquid, and placed on a shaker table and then shaken for 2, 12, or 24 hours at a constant temperature. The samples were collected, filtered with 0.45 μm membrane filters, and analyzed immediately using the Orbeco-Hellige™ (Sarasota, FL) low range method for phosphate concentrations between 0.02 and 1.6 mg/L as P (equivalent to HACH method 8048). Samples with concentrations exceeding 1.6 mg/l as P were diluted P. The measurement for absorbance at 880 nm wavelength was in a HACH DR 5000 Spectrophotometer (Loveland, CO) for soluble reactive phosphorus (SRP). The two methods used for NH_3 and NO_x adsorption measurements were the HACH methods 10023 and 8192, respectively.

Furthermore, the researchers measured the pH and temperature measurements of the samples. Temperature and pH ranged between of 21-23°C and 7-8, respectively, for all test runs with Media mix 1. When measured at the end of adsorption experiments, the NH_3 data seemed to indicate that there might be minor adsorption of ammonia, but it was not significant compared to the biological transformations observed in the columns. The NO_x data indicated that there was no sorption of NO_x . However, for SRP, the observation of adsorption was significant for Media mix 1. Tests conducted for initial isotherms used a 2-hour equilibration time and later, a 12-hour equilibration time. In the initial test runs, the data plot followed the Langmuir equation but not the Freundlich isotherm model. Presented below is the linearized form of the Langmuir

equation, used for data analysis (i.e. to obtain the coefficient values for the Langmuir equation). Figure 3-5 shows the two- and 12-hour isotherm data for SRP. The Langmuir isotherm equation (Crittenden et al., 2012) is shown in Equation (1). The parameters are: q_A (i.e. x/m) = the equilibrium adsorbent-phase concentration of adsorbate A, mg adsorbate/mg adsorbent; C_A = the equilibrium concentration of adsorbate A in a solution, mg/L; b_A (i.e. K_{ads}) = the Langmuir adsorption or affinity constant of the adsorbent for the adsorbate, L/mg; and Q_M = the adsorption capacity, concentration of adsorbate when surface sites are saturated with adsorbent.

$$\frac{C_A}{q_A} = \frac{1}{b_A Q_M} + \frac{C_A}{Q_M} \tag{1}$$

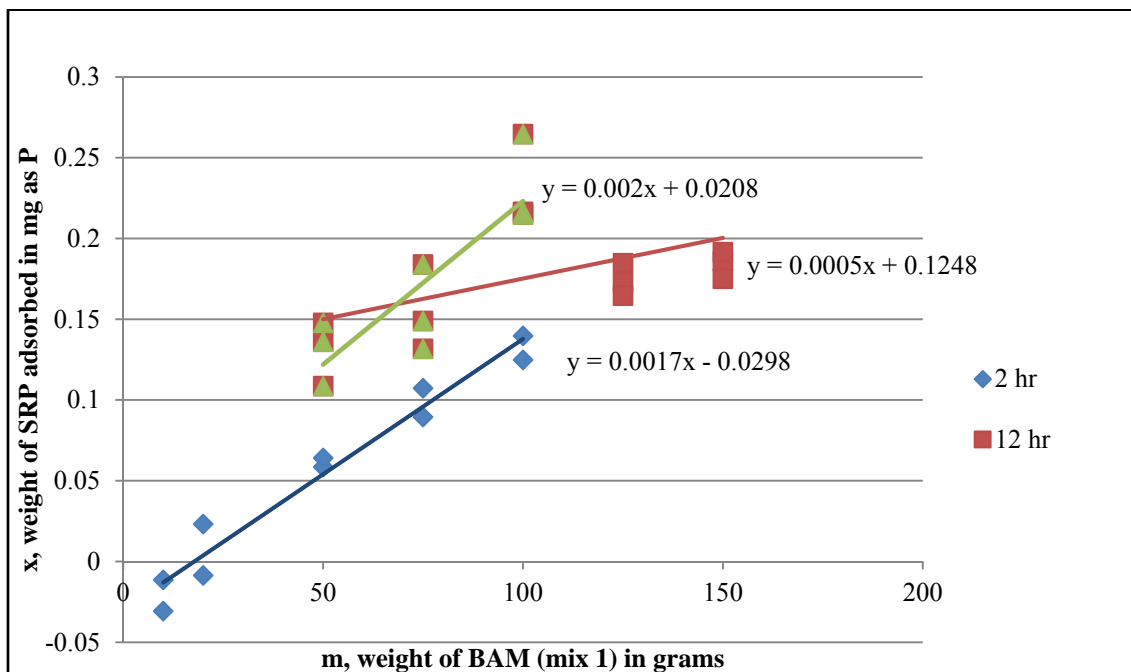

Figure 3-5 SRP adsorbed as a function of BAM mass for the Two-hour and 12-hour runs

As can be seen in Figure 3-5, plots of the weight of SRP adsorbed versus the weight of the BAM media for the two- and 12-hour runs have trend lines that show an increase for SRP adsorbed as the quantity of media increased. The comparison of data between 50 and 100 grams of media mix for the 12-hour run and the two-hour run have consistent slope lines. However, the 12-hour data shows more adsorption than the two-hour data, indicating that two hours run time was too short to reach equilibrium. The 12-hour data at 125 and 150 grams of media mix was inconsistent with the data at 100 grams and less. The inconsistency is described as an artifact of the experiment, possibly caused by the inability of the shaker table to keep the media mix in suspension when the weight of the media were 125 grams or more grams. For media mix quantity greater than 100 grams, the media stratified and clay particles formed a single unmixed layer at the bottom of the flasks.

Figure 3-6 shows the two-hour isotherm data. It yields a linear relationship, which implies that the Langmuir equation can describe the data. Figure 3-7 shows the data for the 12-hour equilibrium test but the data is not linear. Excluded from Figure 3-8 were data with greater than 100 grams, which resulted in improvement in the relationship, but still does not show as linear relationship as was the two-hour test data.

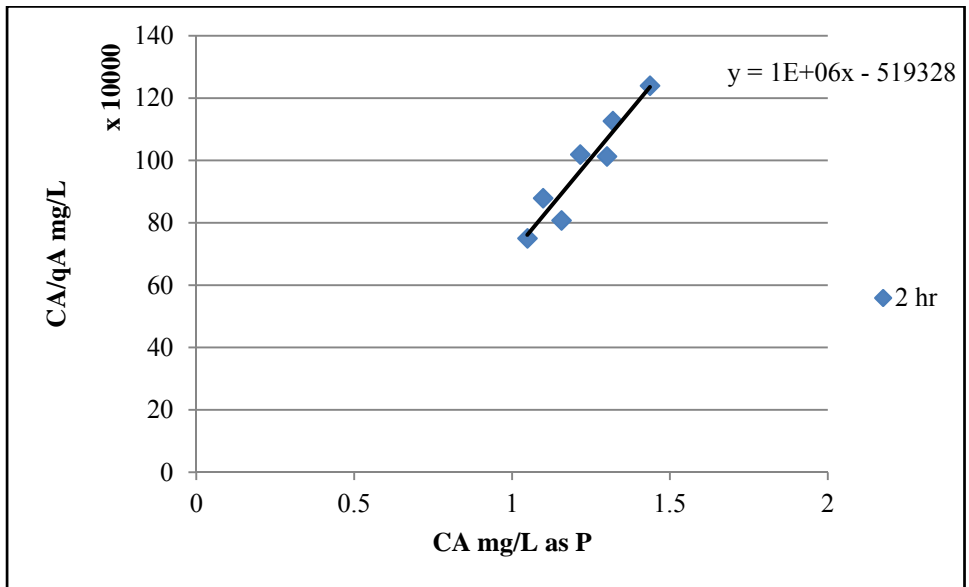

Figure 3-6 Langmuir graph for the two-hour run

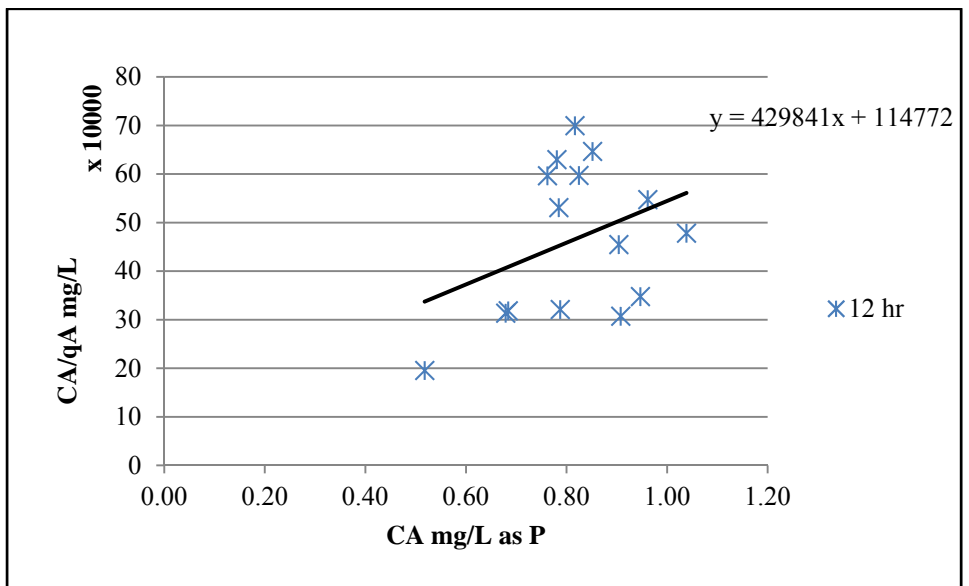

Figure 3-7 Langmuir graph for the 12-hour run

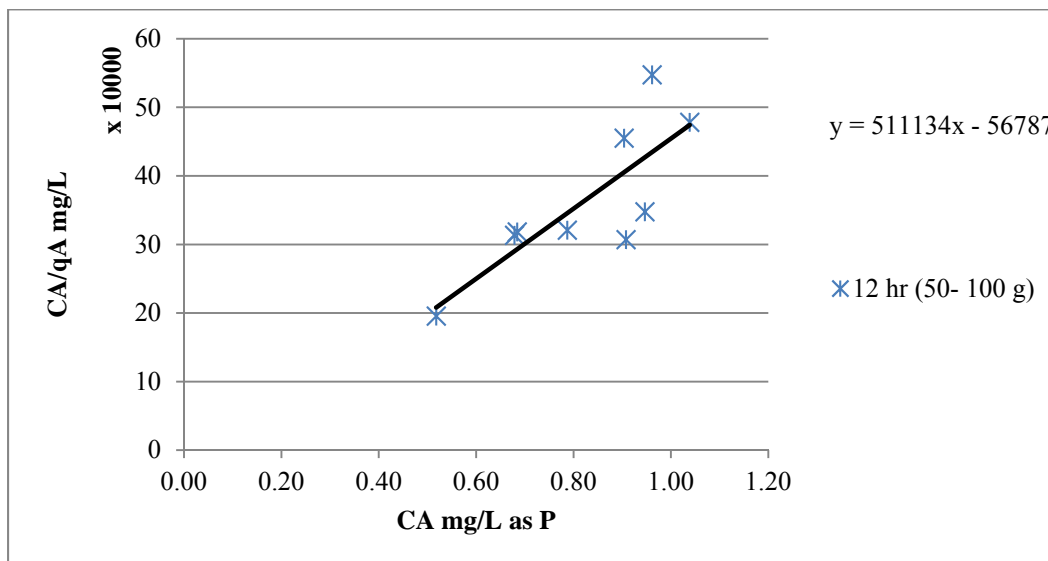

Figure 3-8 Langmuir graph for the 12-hour test run (50-100 g media only)

Table 3-23 shows the Langmuir isotherm constants. The maximum amount of adsorbate (Q_M) is roughly three times higher for the 12-hour test, which is indicative that it takes more than two hours to achieve equilibrium. Figure 3-9 shows the results of an experiment conducted to determine how long it would take to reach equilibrium.

Table 3-23 Langmuir isotherm equation parameters

	Two-hr.	12-hr.	12-hr. (50-100g)
Slope	1.00E+06	429841	511134
Q_m mg/mg	1.00E-06	2.33E-06	1.96E-06
intercept	-519328	114772	-56787
b_A , L/mg	-1.925565	3.745173039	-9.000898093

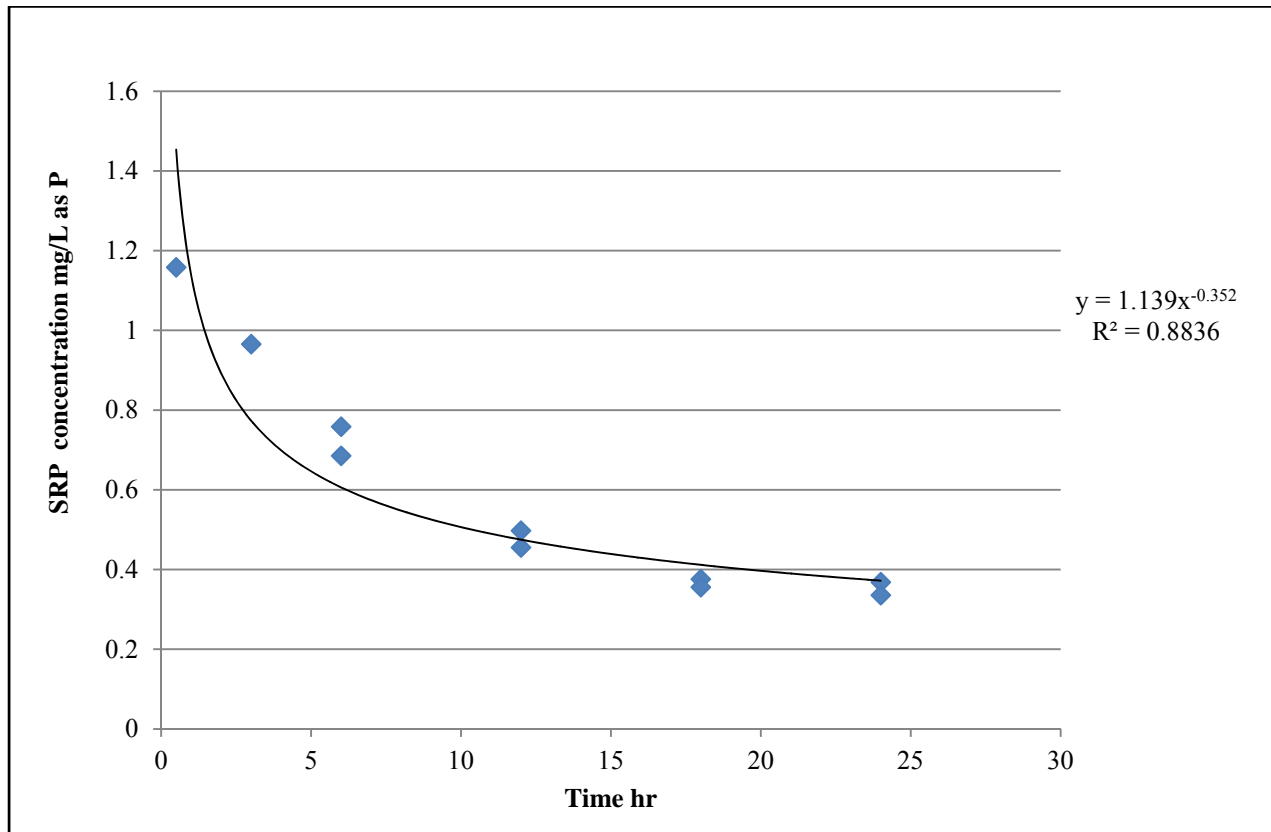

Figure 3-9 SRP Time Series For 50 grams of Media

Figure 3-9 shows the trend over time for the Media (Mix 1) with the initial P concentration being the background concentration of the stormwater plus an SRP spike of 1.0 mg/L as P. The difference between each two consecutive points ranges between 17%- 32% except for the 18-hour and the 24-hour. The 18- and 24-hour samples yielded a difference of less than 5%, which confirmed that a 24-hour run was sufficient to reach equilibrium.

The study performed time series experiment using ten-500 mL Erlenmeyer flasks all filled with 50 grams of media and 300 mL of spiked pond water (1.0 mg/L as P). The procedure was the same as the 24-hour isotherms, except that all flasks had the same concentration, same

amount of media, but a different residence time. That is the time for analysis of samples in the flasks were at different times of 30 minutes, 3, 6, 12, 18, and 24 hours.

The test results shown in Figure 3-9 were from two 24-hours Isotherm experiments at equilibrium. The 24-hour Isotherms experiments conducted used different concentration of the sorbate (phosphorus) and a constant amount of media. The spike concentrations used were 0.5, 1, 5, 10, and 20 mg/L as P. The spike volume was negligible because the experiments used a 100 mg/L as PO₄²⁻ (32.7 mg/L as P) standard solution for 0.5 and 1.0 mg/L as P, and a 1000 mg/L as PO₄²⁻ (327 mg/L as P) standard solution for 5, 10, and 20 mg/L as P. The media amount used was 50g for all the 500 ml Erlenmeyer flasks. The rest of the procedure was the same as that for the two- and 12-hour tests.

For the 24-hour test runs with Media mix 1, the pH and temperature ranged between 7-8 and 21-23°C respectively,. The SRP shows significant adsorption for Media mix 1 at 24 hours. The data plotted follows both the Langmuir equation (in contrast to the two- and 12-hour test data) and the Freundlich isotherm model. The Freundlich equation for data analysis is shown in Equation (2) (Crittenden et al., 2012):

$$q_a = K_a C_a^{1/n} \tag{2}$$

Equation (3) is the linearized equation where q_A (i.e. x/m) = the equilibrium adsorbent-phase concentration of adsorbate A, mg adsorbate/mg adsorbent; C_A = the equilibrium concentration of adsorbent A in a solution, mg/L; K_a = the Freundlich adsorption capacity parameter, (mg/mg); $1/n$ = the adsorption intensity.

$$\log(q_a) = \log(Ka) + \left(\frac{1}{n}\right) \log(Ca) \tag{3}$$

Table 3-24 shows that there is significantly more P adsorbed in the two 24-hour test runs than there were in the two- and 12-hour test runs. Both trend lines for the plot of weight of SRP adsorbed versus the initial concentration of phosphorus for the 24-hour test runs showed that the amount of SRP adsorbed increased as the initial P concentration increased (Figure 3-10). However, in Figure 3-11, the plot was q_A versus the equilibrium concentration of P, and the curvilinear relationship was consistent with either the Langmuir or Freundlich models rather than linear adsorption. The determination of whether q_A would reach a maximum value (Langmuir model) or remain curvilinear (Freundlich model) would require data at higher equilibrium concentrations. However, such a concentration range are not common for stormwater.

Table 3-24 Adsorption comparison per unit media at 1 mg/L as P for the 2-, 12-, and 24-hour test runs

	Two-hour	12-hour	24-hour - 1	24-hour - 2
weight of media in g	50	50	50	50
Co mg/l as P	1	1	1	1
x/m mg/g	0.00123	0.00245	0.00441	0.00400

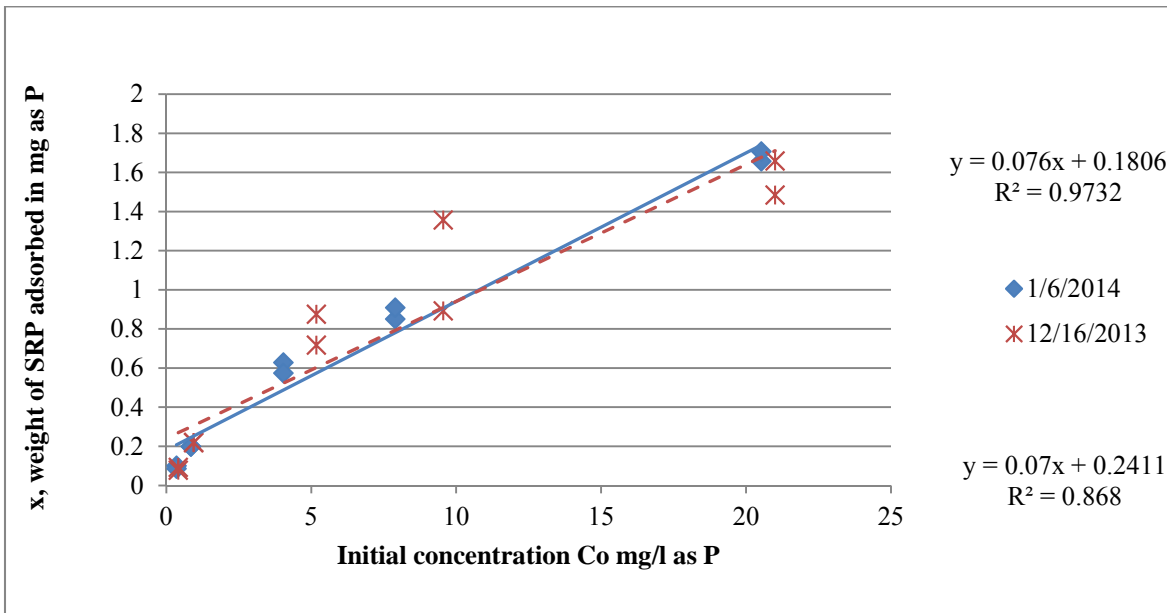

Figure 3-10 SRP adsorbed as a function of the initial concentration for the 24-hour tests

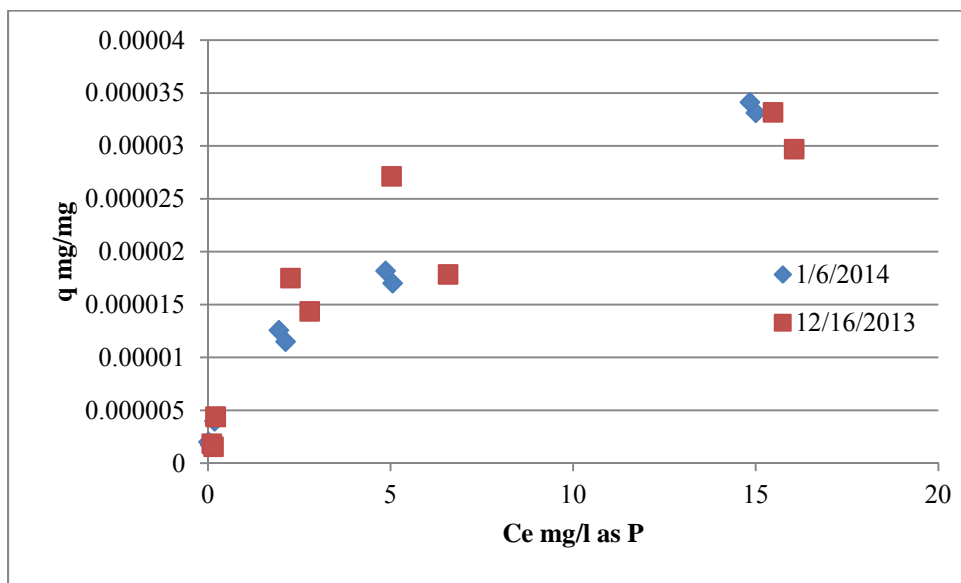

Figure 3-11 q (mg/mg) versus equilibrium SRP concentration for the 24-hour tests

Table 3-25, Figure 3-12, and Figure 3-13 show the Freundlich isotherm graphs and the corresponding constants for the two 24-hour isotherm experiments. The adsorption capacity parameter (K_a) is almost the same for both runs with only a 10 percent difference.

Table 3-25 Freundlich isotherm equation parameters run 24-hour - 1 and 24-hour - 2

	(24-hour. - 1) Freundlich	(24-hour. - 2) Freundlich	Average
slope 1/n	0.560	0.433	0.497
n	1.784	2.308	2.046
intercept	-5.103	-5.040	-5.072
K_a mg/mg	7.88315E-06	9.11381E-06	8.49848E-06

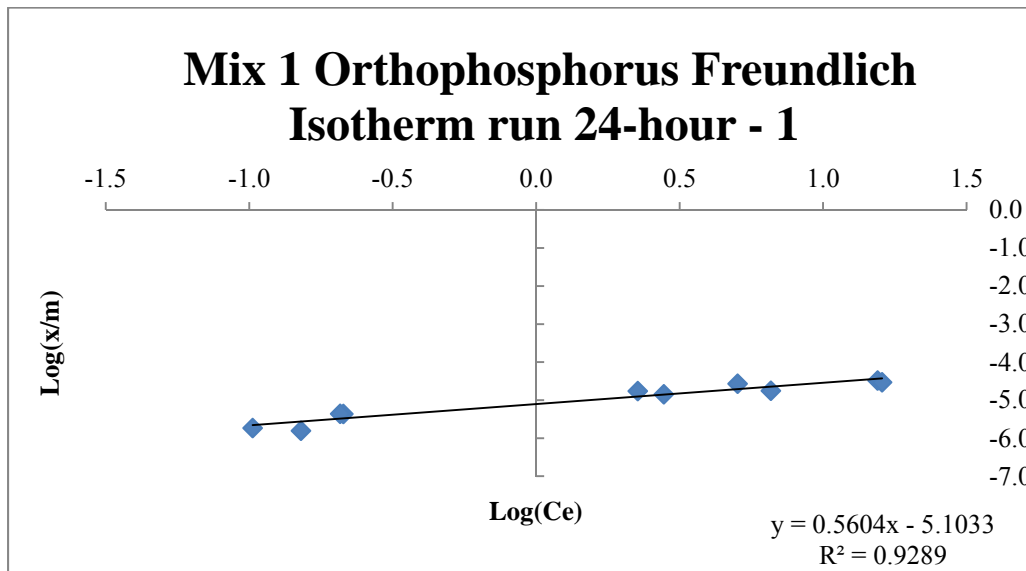

Figure 3-12 Orthophosphorus Freundlich Isotherm run 24-hour - 1

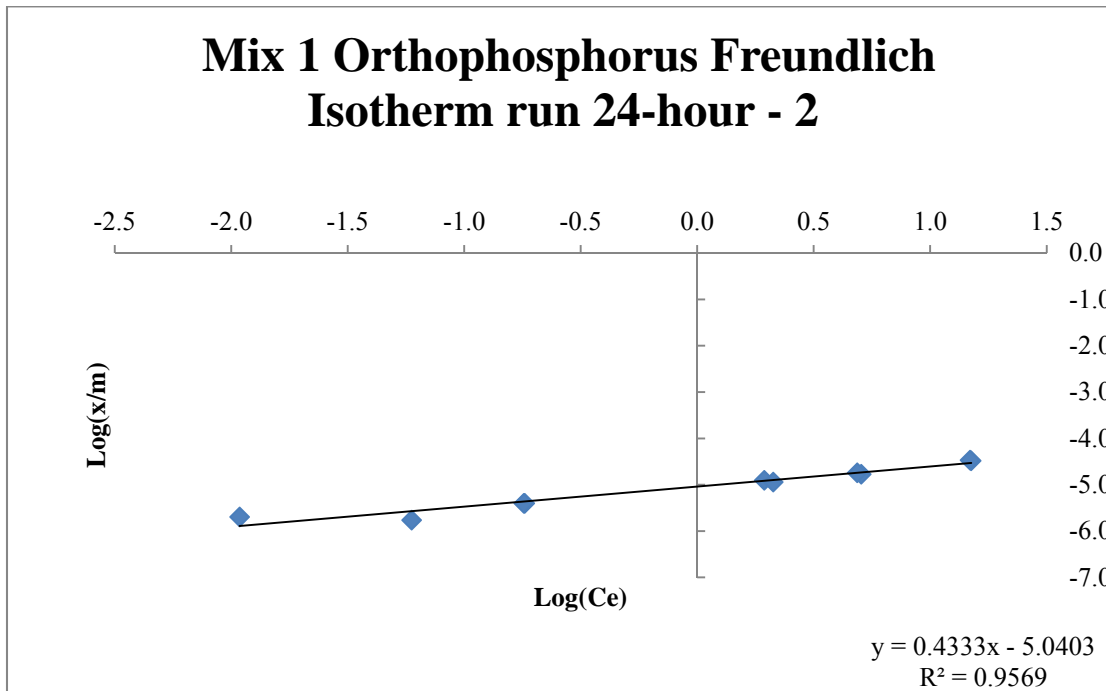

Figure 3-13 Orthophosphorus Freundlich Isotherm run 24-hour - 2

Table 3-26, Figure 3-14, and Figure 3-15 show the Langmuir isotherm graphs and the corresponding constants, which are consistent. The maximum amount of adsorbate (Q_M) for the 24-1 run is almost identical to that of the 24-2's with only a 6% difference. The Langmuir adsorption constant of adsorbate (b_A) is similar for both runs with a five percent difference.

Table 3-26 Langmuir isotherm equation parameters run 24-hour - 1 and 24-hour - 2

	(24-hour. - 1) Langmuir	(24-hour. - 2) Langmuir	Average
slope	28559	26878	27719
Q_m mg/mg	3.50152E-05	3.72051E-05	3.61102E-05
intercept	73444	73053	73249
b_A	0.3889	0.3679	0.3784

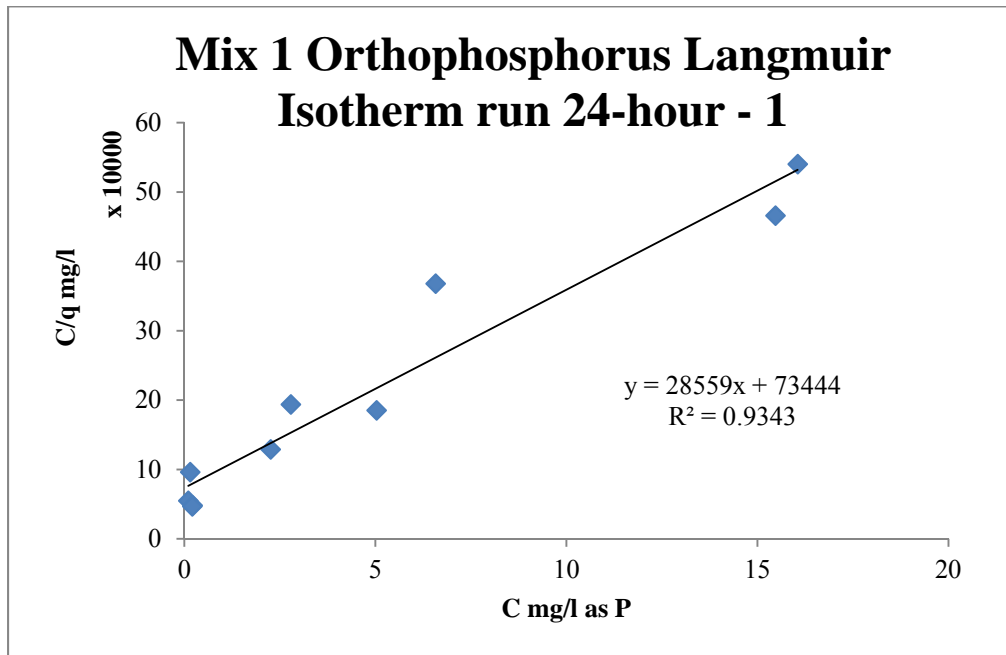

Figure 3-14 Orthophosphorus Langmuir Isotherm run 24-hour - 1

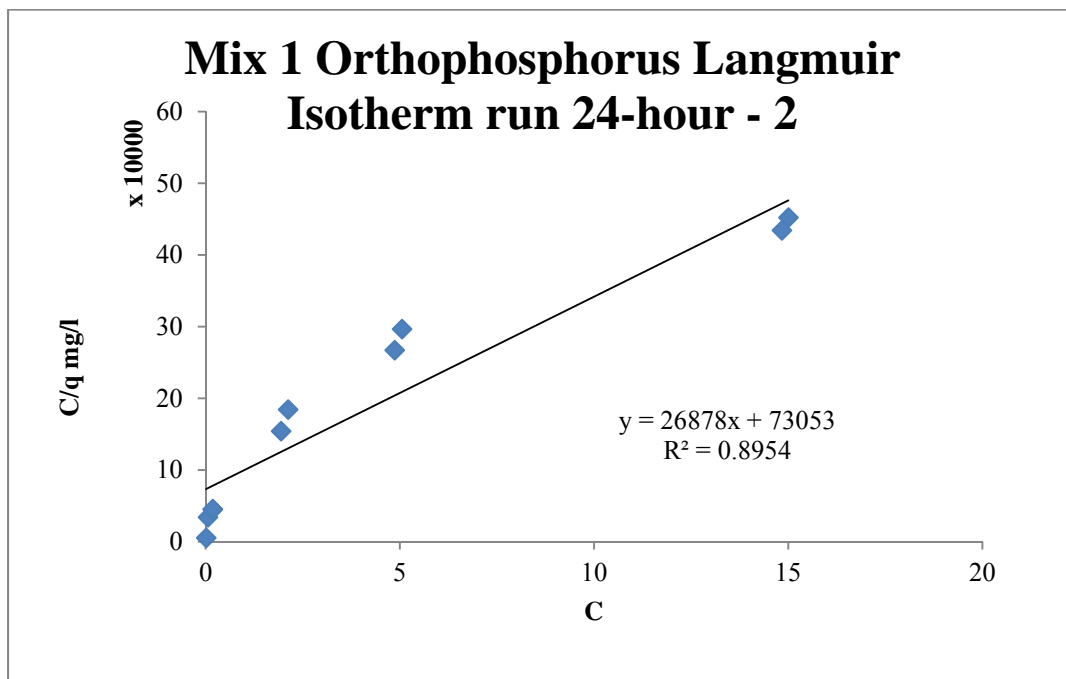

Figure 3-15 Orthophosphorus Langmuir Isotherm run 24-hour

Both models (Freundlich and Langmuir) were suitable for both 24-hour runs (24-1 and 24-2). However, the Langmuir model parameter values were closer for the two tests (Table 3-26) compared to the Freundlich parameter values (Table 3-25). This may imply that the Langmuir model fits the data better than the Freundlich model, but both model fits are acceptable. In future research, the authors recommend the evaluation of equilibrium P concentrations greater than 20 mg/L to determine the projection of the trend lines in Figure 3-11 (if the relationship approaches a constant value, consistent with the Langmuir model, or instead remains curvilinear, would be consistent with the Freundlich model). However, this study did not investigate such high concentrations of P because it was not representative of stormwater conditions.

3.5.11.1 Life Expectancy

The isotherm data analyzed using the Langmuir isotherm indicates a Q_M of at least 3.6×10^{-5} mg/mg. However, the isotherm experiments conducted were for equilibrium phosphorus concentrations below 16.1 mg/L; thus, the estimate was from an extrapolation, which assumed an almost perfect fit of the data with the Langmuir model. The constants derived describe the data very well for equilibrium concentrations of 16.1 mg/L as P, but above that level, it is only possible to extrapolate. The Freundlich model does not incorporate an estimate of maximum sorption capacity and cannot yield any information on the sorption capacity because it used the same data set. Thus, an estimate of the maximum sorption capacity would depend on extrapolation for concentrations above 16.1 mg/L as P.

From the column data, the highest q (x/m) observed was 8.84×10^{-5} mg/mg. This value was significantly higher than the Q_M estimate obtained by extrapolating the Langmuir isotherm. In addition, no sign of column breakthrough with respect to phosphorus, which means 8.84×10^{-5}

mg/mg is the lower boundary. However, Media mix 1 is capable of more than 8.84×10^{-5} mg/mg of adsorption but there is no experimental data to show how much more. Previous design experience with BAM media indicated that 50.0×10^{-5} mg/mg (i.e. 0.5 mg/gram media) is a reasonable estimate of the sorption capacity with respect to phosphorus. For SRP, the observed P removals were approximately 0.1 mg/L as P in the column study, which reasonably agrees with prior experience in BAM study.

If the stormwater BAM unit receives about 6 acre-feet of runoff and the goal is a lifespan of two years (i.e. a replacement time of two years) then there would be 7.4 million liters of stormwater treated in that time period, implying 740,000 mg of SRP to be removed. If the design sorption capacity of 0.5 mg/gram media is accepted, then 1,480 kg (3,263 lbs) of media are needed, which at a density of 33 lbs/CF means 99 ft³ of media would be required for a two-year period. Using the observed q from the column study as though it were a maximum (which it is not), would increase the media requirements to 559 ft³. The corresponding hydraulic loads would be 3.70 ft³/ft³*day for a maximum P sorption of 0.5 mg/gram, and 0.654 ft³/ft³*day for 0.0884 mg/gram. However, since there was no observed breakthrough, a two-year lifespan would require significantly less than 559 ft³ of media for treatment of six acre-feet of runoff, and the expected amount would be closer to 99 ft³ of media.

CHAPTER 4: PHYSIO-CHEMICAL PROPERTY CHARACTERIZATION OF BAM FOR NUTRIENT REMOVAL

4.1 INTRODUCION

Sorption media filters are one of the many BMPs used in the reduction of phosphorus. The constituents of the sorption media filters are clay, sand, organic materials, or engineered compounds to remove more SRP and TP (Chang *et al.*, 2010; Wanielista *et al.*, 2008; Xuan *et al.*, 2009 (a)). The sorption media filters are capable of removing phosphorus by physical, chemical, and biological means; and biologically remove nitrogen species via nitrification and denitrification (Xuan *et al.*, 2009 (b)). The following factors of pH, chemical composition of material, and element competition in the contaminated water influence a media's removal efficiency of phosphorus. Different interferences in the absorption of orthophosphate may occur because all stormwater runoff may have different chemical composition.

A wide variety of sorption media has been effective at reducing nutrient levels for stormwater. These sorption media include recycled material mixtures (Wanielista *et al.*, 2008); mineral-based mixtures such as marble chips (Sengupta and Ergas, 2006) and oyster shells (Namasivayam *et al.*, 2005); and organic materials such as leaf mulch (Ray *et al.*, 2006), wood chips (Seelsaen *et al.*, 2006), and alfalfa (Kim *et al.*, 2003). Although, many of these materials were extremely effective at adsorbing phosphorus, they may not be applicable in a sorption media reactor with limited interaction time between the media and the water containing phosphorus. The study reviewed the literature on multiple materials for phosphorus removal efficiencies and sorption properties, which include the: 1.) removal efficiencies as evidenced in

the literature; 2.) available surface area; 3.) particle size to avoid clogging of the baffle box; 4.) cost; 5.) availability in Florida; and 6.) additional benefits. Table 4-1 presents the information found in the literature on phosphorus removal efficiencies and absorption properties. Based on the literature reviewed, the study created two mixtures, which (were economical and environmentally friendly (the inclusion of recycled material).

Table 4-1 Literature Review of Sorption Media Used by Different Researchers to Treat Wastewater (Adapted from Chang *et al.*, 2010)

No.	Sorption Media	Additional Environmental Benefits	Physical/Chemical Properties	References
1	Sandy Coastal Soil			Harris <i>et al.</i> (1996)
2	Compost	O/G, heavy metals	Maple & elm leaf compost	Richman (1997)
3	Peat			DeBusk <i>et al.</i> (1997)
	Wollastonite			
	Limerock			
	Sand with quartz			
4	Alfalfa		D<4.00mm	Kim <i>et al.</i> (2000)
	Leaf mulch compost		D<2.00mm	
	Sawdust		D<2.00mm	
	Wheat straw		D<4.00mm	
	Wood chips		D<2.00mm	
	Newspaper		D(average)<4.00mm	
	Sulfur		Large particles 2.00-2.36mm and small particles 0.60-1.18mm	
	Limestone			
5	Crushed piping materials	Organics		Li <i>et al.</i> (2000)
6	Iron Sulfide			Tesoiero <i>et al.</i> (2000)
7	Peat	Cu, Fe, Pb, Zn		Clark <i>et al.</i> (2001)
	Carbon sand, enretech sand or sand			
	Zeolite			
	Activated carbon			
8	Natural sand (bank filtration)	PAHs	Aspen wood fibers composed of 51% cellulose, 26% hemicellulose, 21% lignin, and 1% ash	Tufenkji <i>et al.</i> (2002)
9	Lignocellulosic material		Mostly pine bark	Tshabalala

No.	Sorption Media	Additional Environmental Benefits	Physical/Chemical Properties	References
			chips	(2002)
10	Clay	Cd, Pb, Ni		Lazaridis (2003)
11	Zeolites			Birch <i>et al.</i> (2005)
12	Opoka			Braun-Howland (2003)
13	Waste medium density fiberboard (MDS) sawdust			Gan <i>et al.</i> (2004)
14	Wood fibers	PAHs	Aspen wood fibers composed of 51% cellulose, 26% hemicellulose, 21% lignin, and 1% ash	Boving and Zhang (2004)
15	Mulch	Lead, TSS, oil and grease		Hsieh and Davis (2005)
	Soil		Sandy loam	
	Sand		Sand	
16	Zeolites	Cu, Pb, Zn		Birch <i>et al.</i> (2005)
	Pure Quartzitic Sand			
17	Allophane			AEC (2005)
	Bentonite		4%-8% CaCO ₃	
	Steel slag			
	Chitin			
	Pumice		Iron (18.2%), aluminum (13.7%), calcium (12.7), magnesium (7.3%) and other	
18	Hard wood mulch	Cu, Cd, Cr, Zn, Pb, DCB, NP, FA, BP	Sliver maple, Norway maple, red oak, and cherry mulch; size 4,760 um	Ray <i>et al.</i> (2006)
19	Wood fibers	Zn, Cu	D = 4 mm	Seelsaen <i>et al.</i> (2006)
	Sand			
	Zeolites			
	Glass		D = 4 mm	
	Ash			
	Compost			
20	Iron sulfide			Baeseman <i>et al.</i> (2006)
21	Metallic iron		D= 0.006-0.01 mm; area 0.31 m ² ·g ⁻¹	Huang <i>et al.</i> (2006)
	Clinoptilolite	Fe	D = 0.18- 4 MM	

*BP, Benzopyrene; D, diameter of the media; DCB, dichlorobenzene; FA, fluoranthene; NP, naphthalene; O/G, oil and grease, TSS, total suspended solids

The physiochemical properties of the media are imperative in determining pollutant removal from stormwater. These physical characteristics will aid in the understanding of the chemical behavior and hydraulics of the sorption media. The investigation of these characteristics will allow the replication and multiplication of media for application as well as assist in insuring similar removal efficiency.

The study documented the physical and chemical properties of the sorption media to remove stormwater pollutants. The properties of interest investigated include particle-size distribution curve, bulk density, porosity, surface area, hydraulic conductivity, void ratio, and phosphorus adsorption. Particle-size distribution curve gives an idea of the grain size of the media or soil and the amount of each particle-size in the distribution. The bulk unit density and voids in aggregate is important in proportioning the media mix and determining the mass/volume relationship. All of these physical properties play into the adsorption capacity of the media and the capacity of a biofilm to grow. These physical characteristics and adsorption properties of the media allow the review of media used as part of the sorption mixtures.

Phosphorus removal characteristics of the media via adsorption are important concepts to understand in order to find the amount of water treated and the extent of maximum removal. The adsorption rate and capacity varies for different exposure conditions, but only two exposure conditions were tested. Thus, the influent concentration and residence times were factors manipulated in the column tests because of the variation of phosphorus adsorption capacity for both conditions. Previous study showed that the sorption of phosphorus in soil/sediments was greater under aerobic conditions (Nurnberg, 1988).

The Thomas model predicts the breakthrough curve for adsorption and ion exchange for gases and liquids (Mustafa and Ebrahim, 2010). The model developed in 1944 is one of the most general and widely used models for adsorption. The base for the Thomas model is on the second-order reaction kinetics and the assumption of Langmuir isotherm to give an analytical solution that allows for a nonlinear equilibrium relationship (Mustafa and Ebrahim, 2010). Based on previous literature of the materials used as sorption media for nutrient removal (Chang et al., 2010; Wanielista et al., 2008; Xuan et al., 2009 (a)), it was hypothesized that media would adsorb orthophosphate at a high efficiency, which should decrease with less exposure or HRT with the orthophosphate solution.

Demonstration Questions Before a demonstration in an ultra-urban setting, there were two basic questions addressed, namely how much orthophosphate can the media remove and how does this vary with contact time? Which mix outperforms the others selected for demonstration? What are the physical properties of each media mix that will influence its adsorption characteristics?

4.2 CHAPTER OBJECTIVES

The objectives of this chapter are to

- Conduct phosphorus adsorption isotherms to find the mass adsorbent removed per mass of media (equilibrium media uptake (q); $\text{mg}\cdot\text{g}^{-1}$).
- Select the outperforming media mix by comparison of removal efficiencies and equilibrium media uptake of the isotherm tests.

- Using the selected BAM mix, vary the contact time (0.5 and 1 hour) in the isotherm tests to find the change in the equilibrium media uptake ($\text{mg}\cdot\text{g}^{-1}$).
- Using ASTM standards, determine porosity, void ratio, specific gravity, bulk density, particle size distribution, and surface area
- Conduct breakthrough column tests on the selected BAM mix to determine and compare the equilibrium media uptake of the media’s corresponding pollutant using the Thomas Model ($\text{mg}\cdot\text{g}^{-1}$).

4.3 METHODOLOGIES

From chapter 3, the results show that media mixes 1 and 3 were effective in nutrient removal. Media mix 1 was shown to be used for an up-flow filter requiring high rates of flow and media mix 3 was shown for a lower flow rate and presumably, higher removal. This chapter presents the study conducted on two mixes of media 3. The two mixes were mineral media that was oven-dried at 105°C and tire chip air-dried for at least one week. Table 4-2 presents the components for the two mixes (prepared by volume) used for isotherm testing, and Table 4-3 presents all analysis methods used to determine orthophosphate and total phosphorus. All samples were filtered using 0.45 μm filters.

Table 4-2 Component of the Two BAM Mixtures by Volume Tested for Nutrient Removal.

BAM Mix 3-1	BAM Mix 3-2
50% Citrus Sand	50% Citrus Sand
20% Limestone	20% Tire Crumb
15% Tire Crumb	20% Expanded Clay
15% Expanded Clay	10% Limestone

Table 4-3 Hach Test Method used to Determine Ortho- and Total Phosphorus Concentrations

Chemical species	Title of Method	Method no.	Measuring range (mg·L ⁻¹ -P)
Orthophosphate-P	USEPA PhosVer®3 (ascorbic acid) method	Method 8048	0.02-1.60
Total Phosphorus-P	USEPA PhosVer®3 acid persulfate digestion method	Method 8190	0.02-1.10

4.3.1 Isotherm Tests

Adsorption is the increase in concentration of a particular component at the surface or interface between the solid and liquid phases. The atoms at the surface are subject to unbalancing forces of attraction and extensions acting within the body of the solid media. Isotherm models are the basis for determining classical breakthrough by the use of fixed-bed column models. Prediction of the effluent concentration breakthrough uses a fixed-bed column operation. The experimental adsorption data are fitted using established isotherm models to determine their appropriate parameters necessary to optimize the adsorption process in field application. The anticipated application for the media will be in a baffle box designed with a constant flow using a pump. The column studies should be a close representative of the adsorption achieved when applied in the field.

The preparation for the isotherm testing involved the addition of 300 mL of a 1.0 mg·L⁻¹-P solution to each of the five 500 mL flasks filled with 50g, 100 g, 150 g, 200 g, and 250 g of a nutrient media mixture. Covered with parafilm to avoid external disturbances, the flasks were thoroughly mixed on a shaking platform for 12 hours at 200 rpm. The solution was extracted from the media, filtered using 0.45 µm filters, and analyzed using the HACH test n tube™ kits for phosphate and total phosphorus. There were triplicates for each test.

After the completion of the 12-hour isotherm, the media mix chosen was the one with the greatest removal efficiency and equilibrium adsorption capacity (q_0). The chosen mix was used to estimate the amount of removal and q_0 of the media under shorter residence times, simulating the BAMs application in a baffle box. Estimated were isotherms for 50g, 150g, and 250g using a 0.5-hour and 1.0 hour HRT, which closely simulate the baffle boxes' retention time. Compared were the results of the isotherm tests and the isotherm equations, given below:

Langmuir isotherm equation: (4)

$$(1/q) = (1/(q_{\max}K_{\text{ads}})) * (1/C) + (1/q_{\max})$$

Freundlich isotherm equation: (5)

$$\log q = \log K + (1/n) \log C$$

where q = Sorbed concentration [mass adsorbate/mass adsorbent]; q_{\max} = Maximum capacity of adsorbent for adsorbate [mass adsorbate/mass adsorbent]; K_{ads} = Measure of affinity of adsorbate for adsorbent; K = Capacity adsorbent [mass adsorbate/mass adsorbent]; C = Aqueous concentration of adsorbate [mass/volume]; n = Measure of how affinity for the adsorbate changes with changes in adsorption density. More information on the isotherm (Freundlich and Langmuir) equations calculated for each test are in Appendix A.

4.3.2 Material Characterization

It is very important to understand the physical properties (i.e. density, specific gravity, void ratio, porosity, and surface area) of the media mixtures, which helps characterize and standardize the media. The characterization and standardization of the media physical properties

are essential in providing clearer understanding of the flow rate and expected performance. The methods and equations used in this section are in Appendix B.

4.3.3 Breakthrough Column Tests

Phosphorus adsorption is one method used to remove phosphorus from the water column. The breakthrough curve is determined using a continuous influent containing a target substance. The target substance is influent to a column packed with the adsorbent (media) being tested (Lin *et al.*, 2013). To design such an adsorption process, it is important to understand the kinetic characteristics of the adsorbent and adsorbate(s). Breakthrough curves may be the most common basis for Isotherm shapes and were the basis for interpretation of classical breakthrough curves by Glueckauf adsorbent behavior assessments. Breakthrough curves are a large function of residence time, adsorbent concentration, mass of adsorbent, and other operating conditions. The results of the breakthrough curve may vary because of other factors such as diffusion, dispersion, and reaction kinetics.

The column experiment was prepared using three Plexiglas columns having equal diameter of 5.08 cm (2.0 inches) and length of 30.48 (1.0 ft.). A pipe threat sealant and silicon applied on all joints of the column was to make the column assembly leak-proof. A filter placed at the bottom of the column was to prevent the outward flow of finer particles and glass beads and a filter placed at the top was to assist dispersion. Flow through the column was continuous until adsorption leveled off. The maximum adsorption equilibrium was determined using the Thomas model.

Linear Form:

(6)

$$\frac{C_e}{C_o} = \frac{1}{1 + \exp\left[\frac{1}{K_T}(q_o m - C_o V)\right]}$$

Non-linear Form:

(7)

$$\ln\left(\frac{C_e}{C_o} - 1\right) = \frac{K_T q_o m}{Q} - \frac{K_T C_o V}{Q}$$

where C_e = Effluent Concentration ($\text{mg}\cdot\text{mL}^{-1}$); C_o = Influent Concentration ($\text{mg}\cdot\text{mL}^{-1}$); K_T = Kinetic Coefficient ($\text{mL}\cdot\text{mg}^{-1}\cdot\text{min}^{-1}$); q_o = equilibrium media uptake ($\text{mg}\cdot\text{g}^{-1}$) (when $C_e=C_o$); m = Total media mass in the column (g); Q = Volumetric flow rate ($\text{mL}\cdot\text{min}^{-1}$); and V = Throughput volume (mL).

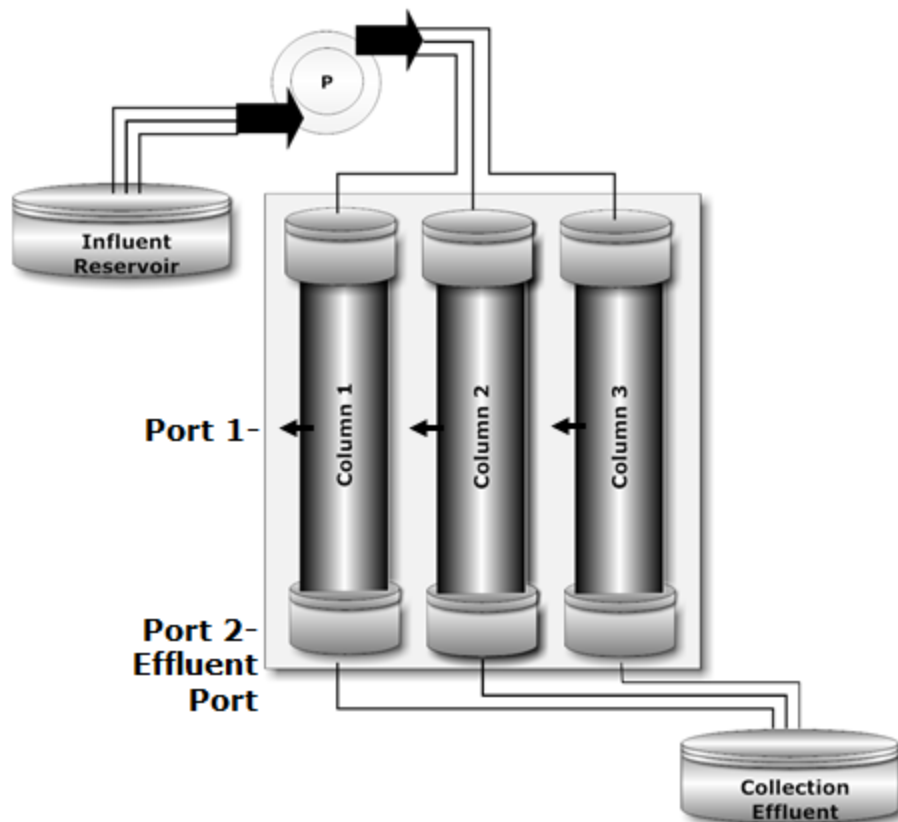

Figure 4-1 Schematic set up of the triplicate column study.

4.3.4 Statistical Analysis

Fitted by a linear model and evaluated using a two-tailed t-test were the isotherm data to determine whether the adsorption curves are significantly different from each other because of the manipulation of the influent concentration or residence time within the column. Linearized form of the raw data from each column are in the plot of $\ln[(C_o/C_e) - 1]$ versus t . (Figure 4-8; Figure 4-9; and Figure 4-10). Each analysis was considered significant at a confidence interval of 95% ($\alpha = 0.05$).

The use of the linear model was to compare the differences in the adsorption curves generated by differing influent concentrations. The linear model used for the comparison analysis is

$$\hat{Y} = \beta_0 + \beta_1 * Time * \beta_2 * (C_0 = 1) + \beta_3 * Time * (C_0 = 1) \tag{8}$$

where $\hat{Y} = \ln \left[\left(\frac{C_o}{C_e} - 1 \right) \right]$ and $(C_0 = 1)$ is an indicator variable that takes on the value 1

when the C_0 is "1" and takes on the value zero when the C_0 is not "1".

Statistical analyses uses the “R” statistical software to define variability in orthophosphate removal. The linear model used for prediction for

$$\hat{Y}_{C_0=1.0} = \beta_0 + \beta_2 + (\beta_1 + \beta_3) * Time \text{ and otherwise, the prediction for } \hat{Y}_{C_0=0.5} = \beta_0 + \beta_1 * Time$$

There were some significant differences in the orthophosphate adsorption curves (Figure 4-11 vs. Figure 4-13) generated by changing the residence time within the column between 18 minutes and 60 minutes. For a two-tailed t- test, the hypothesis for the analysis to determine the intercepts is that $H_0: \beta_0 = 0$ and $H_1: \beta_0 \neq 0$

The interpretation of this p-value is that the null hypothesis results when the regression coefficient is zero. Rejecting the null hypothesis means that the regression coefficients, representing the slope of the line, are significantly different. The same interpretation is applicable for the prediction of the slope having a hypothesis analysis of $H_0: \beta_3 = 0$ and $H_1: \beta_3 \neq 0$. These results will indicate if the generated slope and intercept of the orthophosphate adsorption curves (Figure 4-11 vs. Figure 4-12) are significant different by changing the influent concentrations of the column tests between 1.0 mg·L-1 and 0.5 mg·L-1.

To compare the differences in the adsorption curves generated by differing hydraulic retention times in the columns (18 min. vs. 60 min.), the data fit a linear model. The adsorption curves generated by Figure 4-11 and Figure 4-13 are significantly different from each other because of the different hydraulic residence times used. Fitted to a linear model were the data and evaluated with a t-test. The raw data from each column was linear, as noted by plotting $\ln[(C_o/C_e) - 1]$ vs. t . (Figure 4-8 and Figure 4-10) to be able to fit a linear model. The linear model used for comparison analysis was:

$$\hat{Y} = \beta_0 + \beta_1 * Time + \beta_2 * (Retentiontime = 60) + \beta_3 * (Retentiontime = 60) \quad (9)$$

where $\hat{Y} = \ln[(C_o/C_e) - 1]$ and $(Retention\ time = 60)$ is an indicator variable that takes on the value 1 when the *Retention time* is "60" and takes on the value zero when the *Retention time* is not "60". Each analysis was considered significant at a confidence interval of 95% ($\alpha=0.05$). Completed are statistical analyses to determine variability in orthophosphate removal. Used was the R statistical software package. The linear model used the prediction for \hat{Y} is $\hat{Y}_{RetentionTime60} = \beta_0 + \beta_2 + (\beta_1 + \beta_3) * Time$ and otherwise, the prediction for \hat{Y} is $\hat{Y}_{RetentionTime18} = \beta_0 + \beta_1 * Time$. For a two tailed t- test, the hypothesis is to determine the intercepts is that: $H_0: \beta_0 = 0$ and $H_1: \beta_0 \neq 0$.

These results will indicate if there is significant differences in the slope and intercept of the orthophosphate adsorption curves (Figure 4-11 and Figure 4-13) generated by changing the residence time within the column between the use of distilled water and pond water from pond H-2.

4.4 RESULTS AND DISCUSSION

4.4.1 Material Characterization

The properties of interest investigated include particle-size distribution curve, bulk density, porosity, surface area, hydraulic conductivity, void ratio, and phosphorus adsorption. The bulk unit density ($1387.5 \text{ kg}\cdot\text{m}^{-3}$) and voids in aggregate (0.3696) defined in Table 4-4 are important in determining the mass of media to apply in a sorption media reactor with known dimension. The calculation for the mass and the adsorption capacity of the media uses the density of the media. The porosity of the media (0.2699) aids in the calculation of the amount of water required for treatment and the residence time within a given structure. The surface area of the media ($0.446 \text{ m}^2\cdot\text{g}^{-1}$) assists in determining the capacity of a biofilm to grow in the media. The particle-size distribution curve (Figure 4-3) shows that 60% of the grain size of the BAM is less than 1.0 mm in diameter, which is rather small and has potential to create head loss and clogging within a filter. Less than 10% of the media had grain diameter sizes larger than 2 mm, which are mostly from the pea gravel and limestone (Figure 4-3).

Table 4-4 Material Characterization of the Most Efficient BAM Nutrient Sorption Media

	Nutrient Sorption BAM Mix 3-2
Dry Density ($\text{kg}\cdot\text{m}^{-3}$)	1387.5
Void Ratio (dimensionless)	0.3696
Porosity (dimensionless)	0.2699
Specific Gravity (G_s)	2.208
Surface Area ($\text{m}^2\cdot\text{g}^{-1}$)	0.446

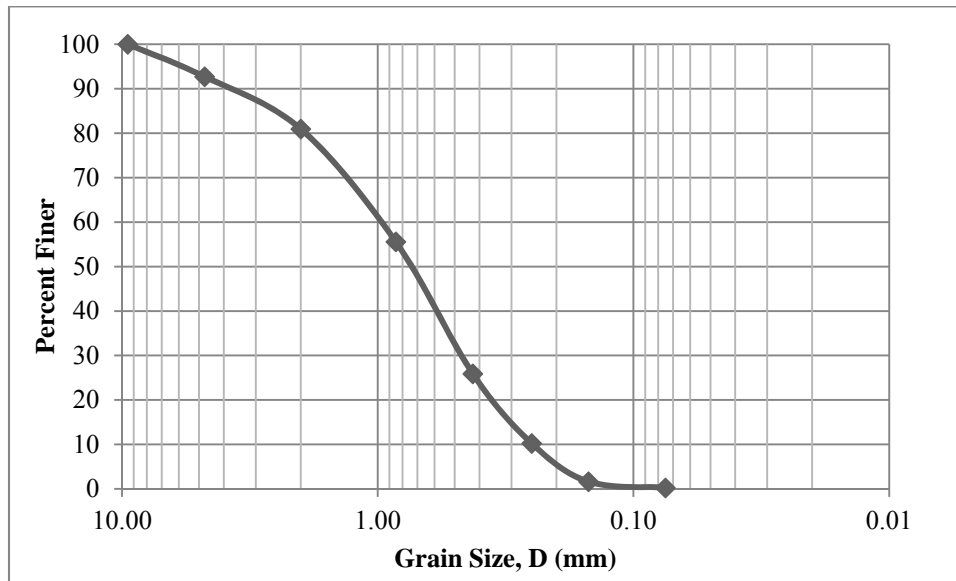

Figure 4-3 Particle size distribution curve of nutrient-sorption media mix 3-2.

4.4.2 Isotherm Results

The results of these tests were mainly abiotic because the clay, sand, and limestone were oven dried at 105°C. Thus, it impossible for bacteria growth on the media in the short time span before the initiation of the experiment. In addition, seeding of bacteria from distilled water spiked with orthophosphate was not likely. Therefore, BAMs capability of removing phosphorus was mainly physiochemical. The findings for the 12-hour isotherm tests (Table 4-5 and 4-3) the compared both BAM mixes, confirmed that BAM mix 3-2 was better than BAM mix 3-1. The study used 250 g of each mix to compare removal efficiencies of ortho-P and total soluble P, respectively. The tests showed that BAM mix 3-1 removed 72.7% and 68.4% while BAM mix 3-2 removed 81.7% and 82.9% of ortho-P and total soluble P, respectively. This is most likely due to the higher content of expanded clay and tire crumbs than limestone in BAM mix 3-2 (20% expanded clay, 20% tire crumb, 10% limestone), and both have greater adsorption capabilities.

However, Mix 3-1 had a higher limestone content than the other two components of the mix (20% limestone, 15% expanded clay, 15 % tire crumb), which worked to precipitate phosphorus rather than adsorb it. Thus, the choice of BAM mix 3-2 for the subsequent isotherm and column testing was because of the greater phosphorus sorption capabilities rather than phosphorus precipitation, which resulted in more phosphorus removal.

Table 4-5 BAM Nutrient Mix 3-1 Isotherm Results for 12-hour contact time

Sample	Media Mass (g)	Extract concentration (mg·L ⁻¹ - P)	Standard deviation	Removal efficiency (%)
(a) Orthophosphate isotherm results				
1	50	0.648	0.053	35.19
2	100	0.561	0.028	43.95
3	150	0.391	0.030	60.91
4	200	0.296	0.021	70.42
5	250	0.273	0.012	72.71
(b) Total soluble phosphorus isotherm results				
1	50	0.669	0.045	33.05
2	100	0.575	0.043	42.48
3	150	0.407	0.024	59.33
4	200	0.336	0.017	66.41
5	250	0.316	0.021	68.43

Table 4-6 BAM Nutrient Mix 3-2 Isotherm Results for 12 hour contact time

Sample	Media Mass (g)	Extract concentration (mg·L ⁻¹ - P)	Standard deviation	Removal efficiency (%)
(a) Orthophosphate isotherm results				
1	50	0.561	0.061	43.87
2	100	0.503	0.038	49.72
3	150	0.318	0.022	68.18
4	200	0.244	0.013	75.56
5	250	0.171	0.017	82.95
(b) Total soluble phosphorus isotherm results				
1	50	0.595	0.052	40.46
2	100	0.528	0.019	47.19
3	150	0.366	0.024	63.43
4	200	0.264	0.010	73.59
5	250	0.183	0.029	81.71

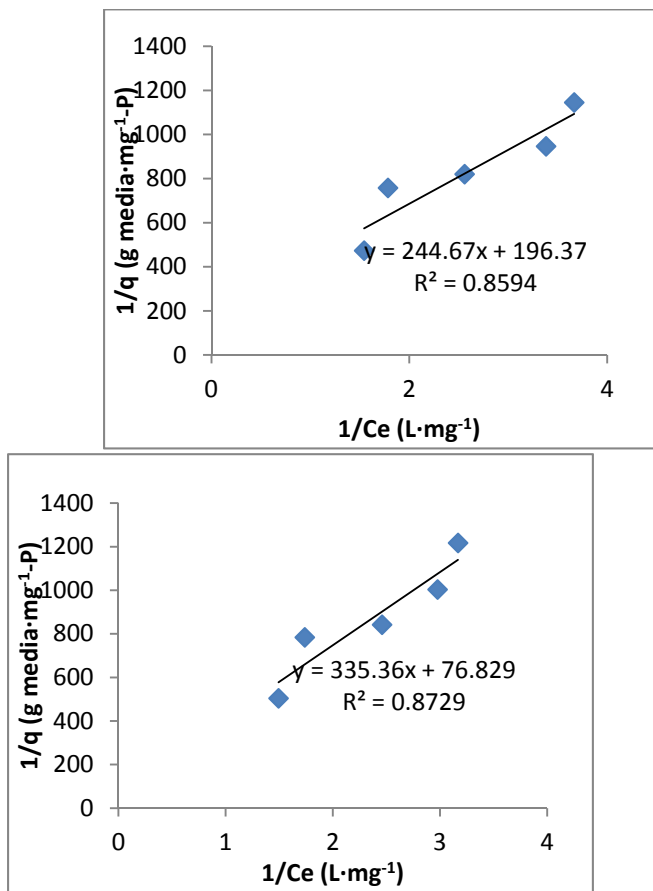

Figure 4-2 to Figure 4-45 show the data from the 12-hour isotherms fitted to Langmuir and Freundlich equations. The regression equations generated from the plots predicted the maximum capacity of adsorbent based on the influent concentrations. The adsorption equilibrium uptake calculated (Table 4-4) from the Langmuir isotherm for an influent concentration of 1.0 mg·L⁻¹ found that the orthophosphate and total phosphorus concentrations for Mix 3-1 were 2.278 μg·g⁻¹ and 2.426 μg·g⁻¹, respectively. For Mix 3-2 the concentrations were 2.335 μg·g⁻¹ and 2.2038 μg·g⁻¹, for orthophosphate and total phosphorus, respectively. The selection of BAM nutrient mix 3-2 was because of it consistently achieved greater phosphorus removal efficiency even though q calculated for ortho-P removal was slightly less than Mix 3-1.

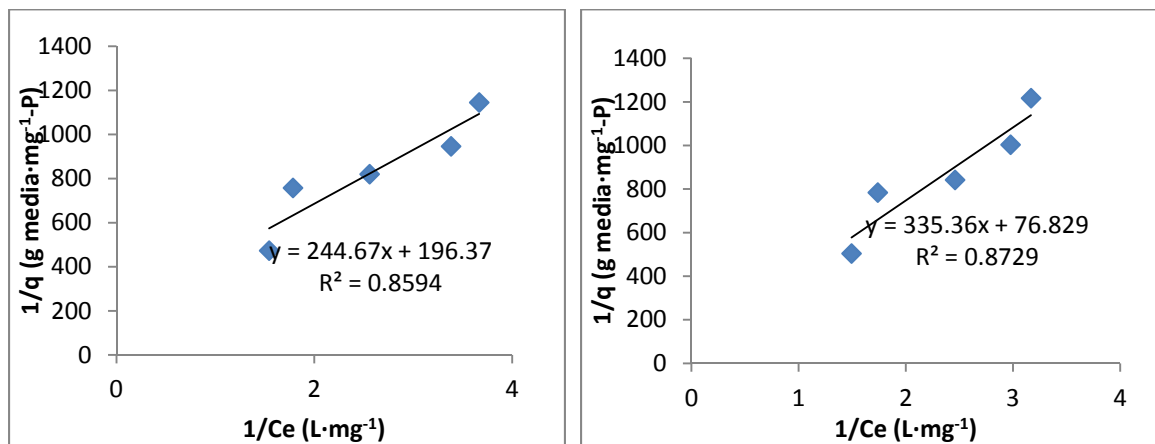

Figure 4-2 Langmuir isotherm data for BAM Nutrient mix 3-1 for (a) orthophosphate and (b) total soluble phosphorus

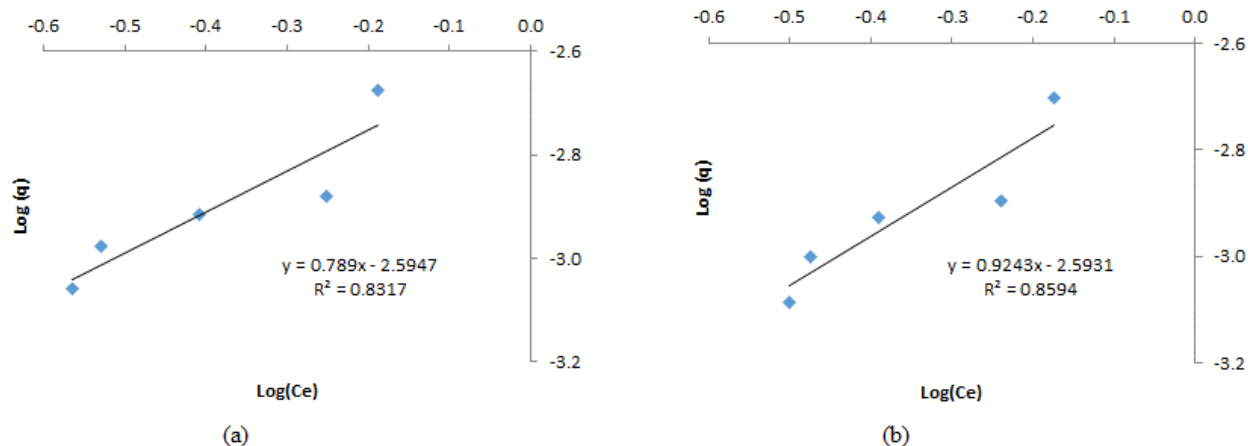

Figure 4-3 Freundlich isotherm data for BAM Nutrient mix 3-1 for (a) orthophosphate and (b) total soluble phosphorus

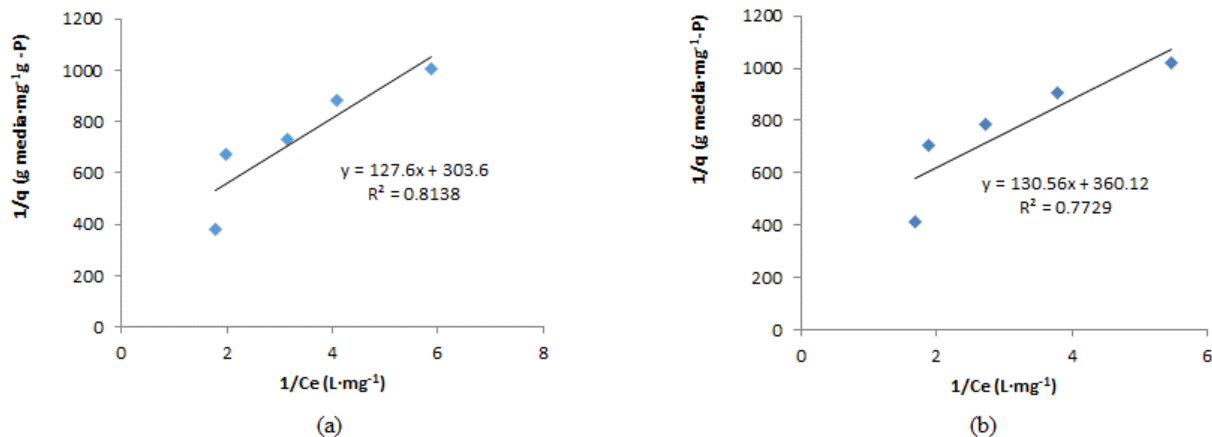

Figure 4-4 Langmuir isotherm data for BAM Nutrient mix 3-2 for (a) orthophosphate and (b) total soluble phosphorus for a 12-hour contact time

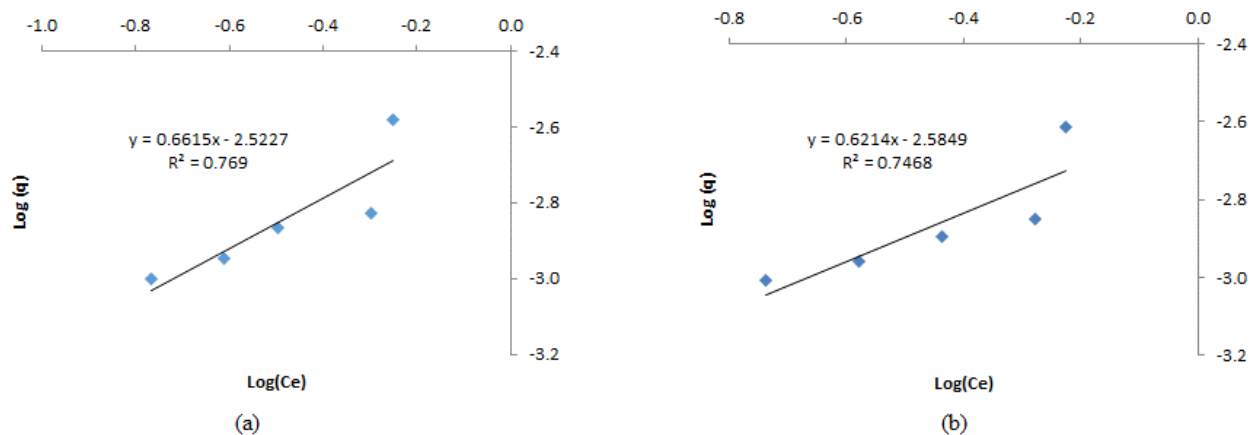

Figure 4-5 Freundlich isotherm data for BAM Nutrient mix 3-2 for (a) orthophosphate and (b) total soluble phosphorus for a 12-hour contact time

Table 4-7 Langmuir isotherm for adsorption of phosphorus chemical species

Chemical Species	Mix	Isotherm equation for Langmuir	R square value	$q_{max}K_{ads}$	K_{ads}	q_{max} ($\mu\text{g}\cdot\text{g}^{-1}$)	q ($\mu\text{g}\cdot\text{g}^{-1}$; $C_0=1 \text{ mg}\cdot\text{L}^{-1}$)
PO ₄ -P	Nutrient 1	$y=244.7x+196.4$	0.856	0.00409	0.803	5.092	2.278
PO ₄ -P	Nutrient 2	$y=127.6x+303.6$	0.814	0.00784	2.380	3.293	2.335
TSP-P	Nutrient 1	$y=335.4x+76.8$	0.877	0.00298	0.229	13.021	2.426
TSP-P	Nutrient 2	$y=130.7x+360.1$	0.773	0.00766	2.758	2.778	2.038

*Note $y=1/q$ and $x=1/C$, q in terms of $\text{mg}\cdot\text{g}^{-1}$ and C in $\text{mg}\cdot\text{L}^{-1}$ unless noted.

Table 4-8 Freundlich isotherm for adsorption of phosphorus chemical species

Chemical Species	Mix	Isotherm equation for Freundlich	R square value	n	K (mg·g ⁻¹ ; C _o =1 mg·L ⁻¹)	K (µg·g ⁻¹ ; C _o =1 mg·L ⁻¹)
PO ₄ -P	Nutrient 1	y=0.789x-2.597	0.832	1.267	0.002593	2.593
PO ₄ -P	Nutrient 2	y=0.662x-2.523	0.769	1.511	0.002999	2.999
TSP-P	Nutrient 1	y=0.924x-2.593	0.859	1.082	0.002553	2.553
TSP-P	Nutrient 2	y=0.621x-2.585	0.758	1.610	0.002600	2.600

*Note y=log q and x=log C, q in terms of mg·g⁻¹ and C in mg·L⁻¹ unless noted.

Table 4-9 and

Table 4-10 present the isotherm studies that showed the decreased phosphorus removal efficiencies when the nutrient media was exposed to the orthophosphate solution for shorter duration (0.5 and 1.0 hour), which would be expected. The total soluble phosphorus removals remained slightly less than the ortho-P concentrations due to transformations in chemical structures.

Table 4-9 Isotherm data for BAM Nutrient mix 3-1 with varying contact time

Sample	Media Mass (g)	Extract concentration (mg·L ⁻¹ - P)	Standard deviation	Removal efficiency (%)
(a) Orthophosphate isotherm results- 12 hours				
1	50	0.561	0.061	43.87
2	150	0.318	0.022	68.18
3	250	0.171	0.017	82.95
(b) Orthophosphate isotherm results- 1 hour				
1	50	0.813	0.020	18.67
2	150	0.555	0.010	44.48
3	250	0.452	0.017	54.77
(c) Orthophosphate isotherm results- 0.5 hour				
1	50	0.747	0.013	15.68

Sample	Media Mass (g)	Extract concentration (mg·L ⁻¹ - P)	Standard deviation	Removal efficiency (%)
2	150	0.411	0.013	36.94
3	250	0.247	0.008	45.85

Table 4-10 Isotherm data for BAM Nutrient mix 3-2 with varying contact time

Sample	Media Mass (g)	Extract concentration (mg·L ⁻¹ - P)	Standard deviation	Removal efficiency (%)
(a) Total soluble phosphorus isotherm results- 12 hours				
1	50	0.595	0.052	40.46
2	150	0.366	0.024	63.43
3	250	0.183	0.029	81.71
(b) Total soluble phosphorus isotherm results- 1 hour				
1	50	0.807	0.034	19.26
2	150	0.516	0.005	48.42
3	250	0.455	0.021	54.53
(c) Total soluble phosphorus isotherm results- 0.5 hour				
1	50	0.841	0.045	15.86
2	150	0.655	0.010	34.52
3	250	0.540	0.022	46.05

Figure 4-6 and 4-7 show that the isotherm data collected gave the maximum performance expectation for the concentrations evaluated. The selection of BAM mix 3-2 was due to its greater adsorption capabilities over BAM Nutrient mix 3-1. The theoretical calculation of the q_{max} for Langmuir isotherms and the K for Freundlich isotherms for these data were not accurate due to the low concentrations evaluated. Therefore, Figure 4-10 shows the maximum q and K values calculated for concentrations within a closer range. For example, the use of a concentration of 1.0 mg·L⁻¹ - P was because the runoff of pond phosphorus concentrations are rarely greater than 1.0 mg·L⁻¹ - P.

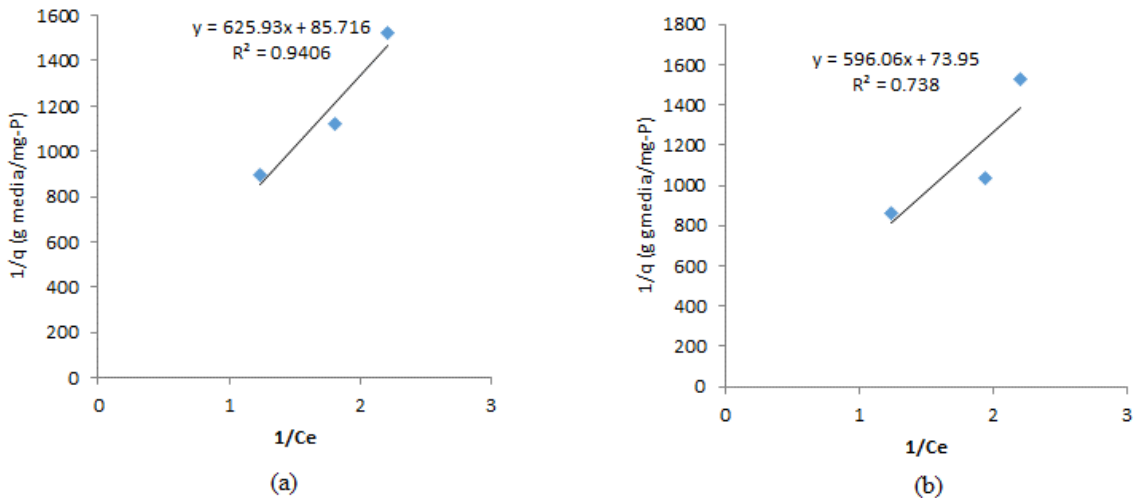

Figure 4-6 Langmuir isotherm data for BAM Nutrient mix 3-2 for (a) orthophosphate and (b) total soluble phosphorus using a 1-hour contact time

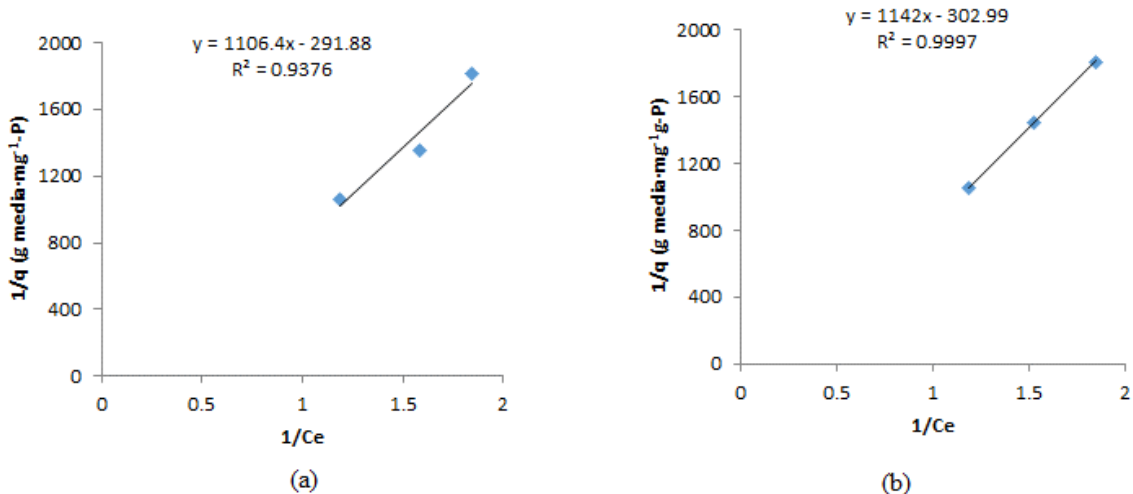

Figure 4-7 Langmuir isotherm data for BAM Nutrient mix 3-2 for (a) orthophosphate and (b) total soluble phosphorus using a 0.5-hour contact time

There were less phosphorus removal after the addition of orthophosphate solution to the media for a 1.0-hour and 0.5-hour contact time.

Table 4-11 shows results with the Langmuir equation and for an influent concentration of $1.0 \text{ mg}\cdot\text{L}^{-1}$. The maximum orthophosphate equilibrium uptake (q) was the greatest for the longest residence time of 12 hours ($2.335 \text{ }\mu\text{g}\cdot\text{g}^{-1}$), and decreased for less residence times of 1.0 hour ($1.405 \text{ }\mu\text{g}\cdot\text{g}^{-1}$) and 0.5 hour ($1.228 \text{ }\mu\text{g}\cdot\text{g}^{-1}$). However, Table 4.9 shows the use of the Freundlich equation to calculate the concentration. The one-hour duration for media exposure had the greatest amount of orthophosphate removed. The total soluble phosphorus had the same trends for both isotherm equations.

Table 4-11 Langmuir isotherm data for BAM Nutrient mix 3-2 at varying residence times

Chemical Species	Contact Time (hour)	Isotherm equation for Langmuir	R square value	$q_{max}K_{ads}$	K_{ads}	q_{max} ($\mu\text{g}\cdot\text{g}^{-1}$)	q ($\mu\text{g}\cdot\text{g}^{-1}$; $C_o=1$ $\text{mg}\cdot\text{L}^{-1}$)
PO ₄ -P	0.5	y=1106.4x-291.9	0.938	0.00090	0.238	-3.426	1.228
PO ₄ -P	1.0	y=625.9x+85.72	0.941	0.00160	0.137	11.66	1.405
PO ₄ -P	12.0	y=127.6x+303.6	0.814	0.00784	2.380	3.294	2.335
TSP-P	0.5	y=1142x-303.0	0.999	0.00088	0.265	-3.330	1.192
TSP-P	1.0	y=596.1x+73.95	0.738	0.00168	0.123	13.52	1.492
TSP-P	12.0	y=130.7x+360.1	0.773	0.00766	2.758	2.777	2.038

*Note y=1/q and x=1/C

Table 4-12 Freundlich isotherm data for BAM Nutrient mix 3-2 at varying residence times

Chemical Species	Contact Time (hour)	Isotherm equation for Freundlich	R square value	n	K ($\text{mg}\cdot\text{g}^{-1}$; $C_o=1$ $\text{mg}\cdot\text{L}^{-1}$)	K ($\mu\text{g}\cdot\text{g}^{-1}$; $C_o=1$ $\text{mg}\cdot\text{L}^{-1}$)
PO ₄ -P	0.5	y=163.9x+444.0	0.999	0.00610	0.001645	1.645
PO ₄ -P	1.0	y=193.3x+100.5	0.693	0.00517	0.004318	4.318
PO ₄ -P	12.0	y=0.662x-2.523	0.769	1.511	0.002999	2.999
TP-P	0.5	y=260.7x+428.7	0.972	0.00384	0.001451	1.451
TP-P	1.0	Y=568.2x-386.1	0.520	0.00176	0.005489	5.489
TP-P	12.0	y=0.621x-2.585	0.758	1.610	0.002600	2.600

*Note y=log q and x=log C, q in terms of $\text{mg}\cdot\text{g}^{-1}$ and C in $\text{mg}\cdot\text{L}^{-1}$ unless noted.

Table 4-13 Average orthophosphate absorption equilibrium uptake, q ($\mu\text{g}\cdot\text{g}^{-1}$), for varying residence times and influent concentrations as determined from the isotherm studies

Influent Concentration, C_o	12.0 hours	1.0 hour	0.5 hour
0.25 $\text{mg}\cdot\text{L}^{-1}$ – P	1.123	0.386	0.242
0.50 $\text{mg}\cdot\text{L}^{-1}$ – P	1.790	0.748	0.520
1.00 $\text{mg}\cdot\text{L}^{-1}$ – P	2.335	1.405	1.228

For these data, the use of the theoretical calculation of the q_{max} for Langmuir isotherms and the K for Freundlich isotherms were not acceptable for this application due to low

concentrations evaluated. It was not possible to have the wide concentration range desired. Therefore, the maximum adsorption equilibrium uptake (q) values were within the range of the influent concentrations of $C_0 = 1.0 \text{ mg}\cdot\text{L}^{-1}\text{-P}$ and $C_0 = 0.5 \text{ mg}\cdot\text{L}^{-1}\text{-P}$. This evaluation is much more relevant to the concentrations evaluated in the study because the pond phosphorus concentrations are rarely greater than $2.0 \text{ mg}\cdot\text{L}^{-1} - \text{P}$.

4.4.3 Column Test and Thomas Model Results

Derivation for the calculations of q_0 and K_T were from the graphs of $\ln[(C_e/C_0) - 1]$ vs. t plotted for effluent concentrations less than 20% removal in column testing shown in Figure 4-8 through Figure 4-10. Presented in the subsequent sections are the graphs from the Thomas model that used values from the column test data. The column studies showed good correlation to the Thomas Model having R^2 values of 0.987, 0.983, and 0.950.

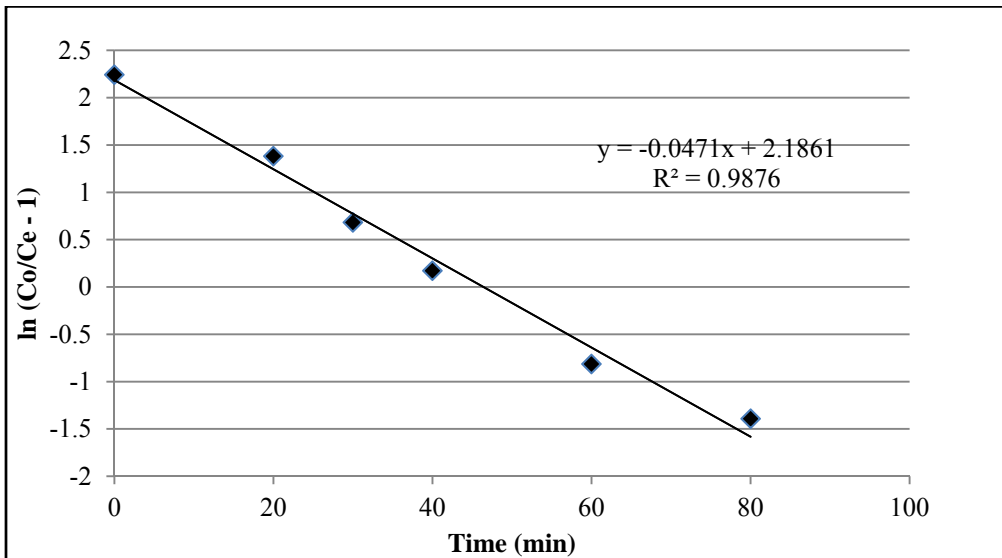

Figure 4-8 Plot of $\ln(C_o/C_e - 1)$ vs. time for BAM nutrient mix 3-2 using phosphorus solution with an initial PO_4 concentration of $1.0 \text{ mg}\cdot\text{ml}^{-1}$ and flow rate of $0.529 \text{ l}\cdot\text{hr}^{-1}$ used to derive values for the Thomas Model

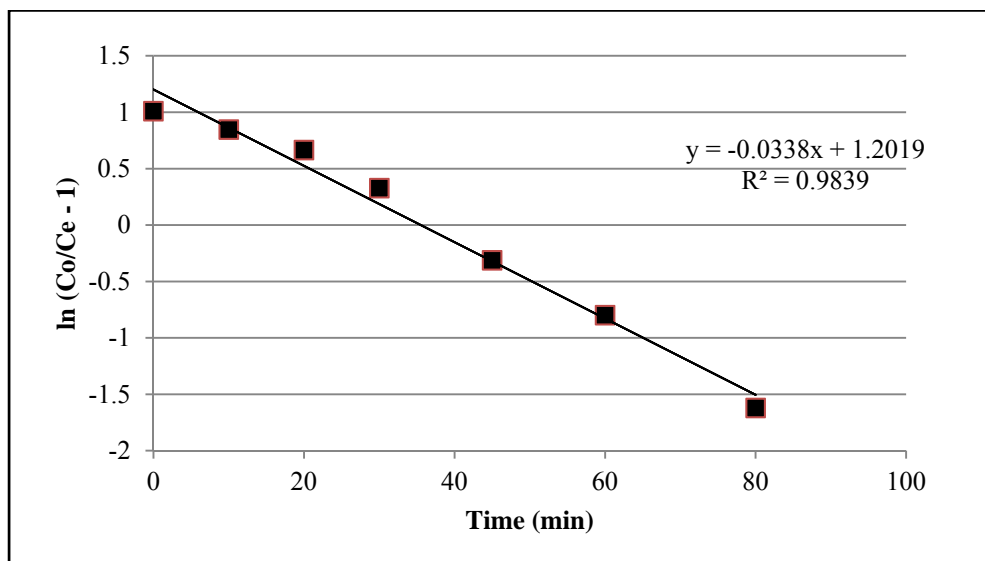

Figure 4-9 Plot of $\ln(C_o/C_e - 1)$ vs. time for BAM nutrient mix 3-2 using phosphorus solution with an initial PO_4 concentration of $0.5 \text{ mg}\cdot\text{mL}^{-1}$ and flow rate of $0.529 \text{ l}\cdot\text{hr}^{-1}$ used to derive values for the Thomas model

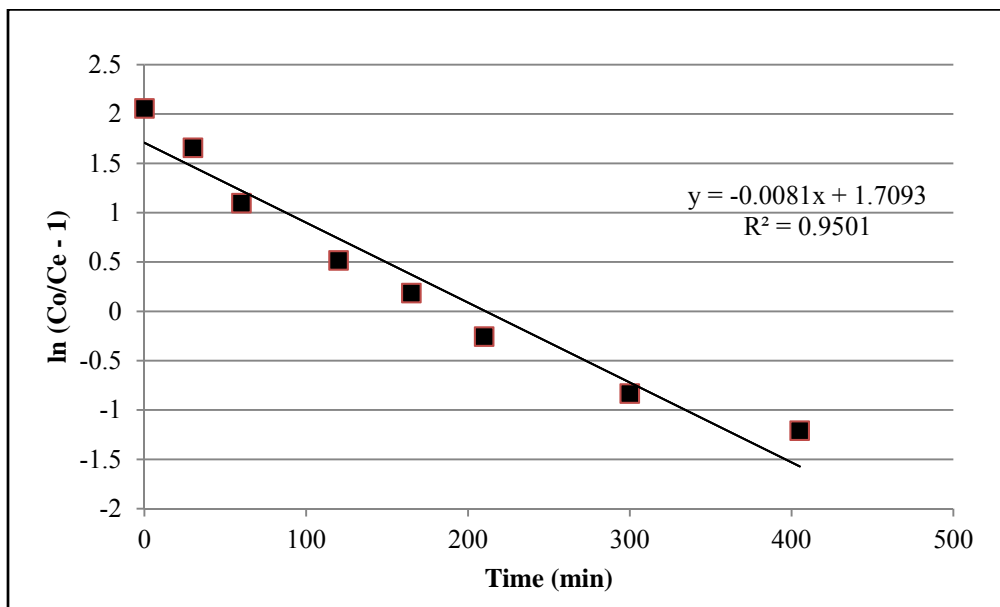

Figure 4-10 Plot of $\ln(C_o/C_e - 1)$ vs. time for BAM nutrient mix 3-2 using phosphorus solution with an initial PO_4 concentration of $1.0 \text{ mg}\cdot\text{mL}^{-1}$ and flow rate of $0.167 \text{ l}\cdot\text{hr}^{-1}$ used to derive values for the Thomas Model

Figure 4-12 shows the shortest breakthrough time for the column with the shortest residence time (18 min) and lowest influent concentration ($0.5 \text{ mg}\cdot\text{L}^{-1} - \text{P}$). On the other hand, Figure 4-13 presents the longest breakthrough time for the column with the longest residence time (18 min) and highest influent concentration ($1.0 \text{ mg}\cdot\text{L}^{-1} - \text{P}$).

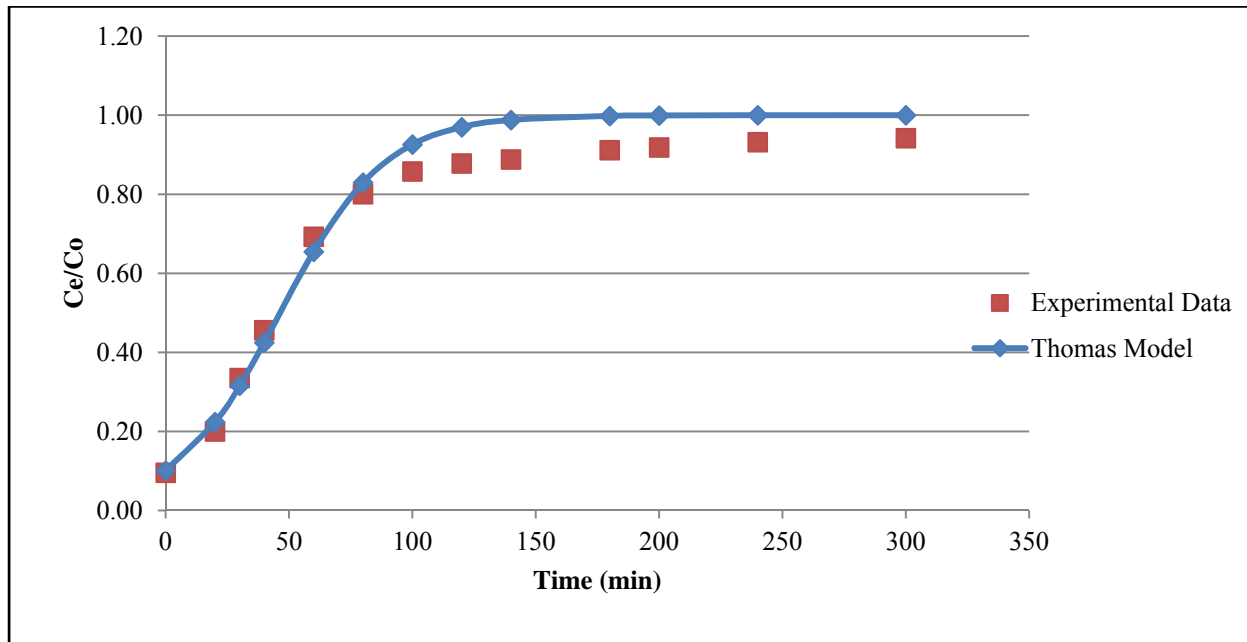

Figure 4-11 Thomas model of breakthrough column with BAM nutrient mix 3-2 using Initial PO_4 concentration of $1 \text{ mg}\cdot\text{mL}^{-1}$ and flow rate of $0.529 \text{ L}\cdot\text{hr}^{-1}$. Experimental data are the average effluent concentrations of the three columns

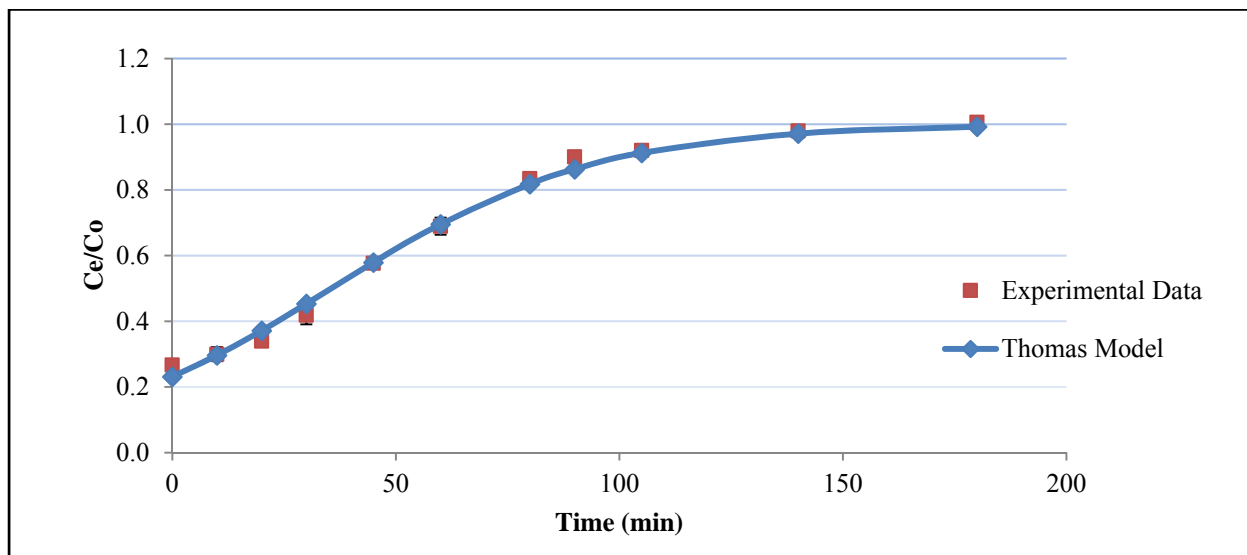

Figure 4-12 Thomas Model of Breakthrough Column with BAM nutrient mix 3-2 Using Initial PO_4 Concentration of $0.5 \text{ mg}\cdot\text{L}^{-1}$ and Flow Rate of $0.529 \text{ L}\cdot\text{hr}^{-1}$. Experimental data are the average effluent concentrations of the three columns

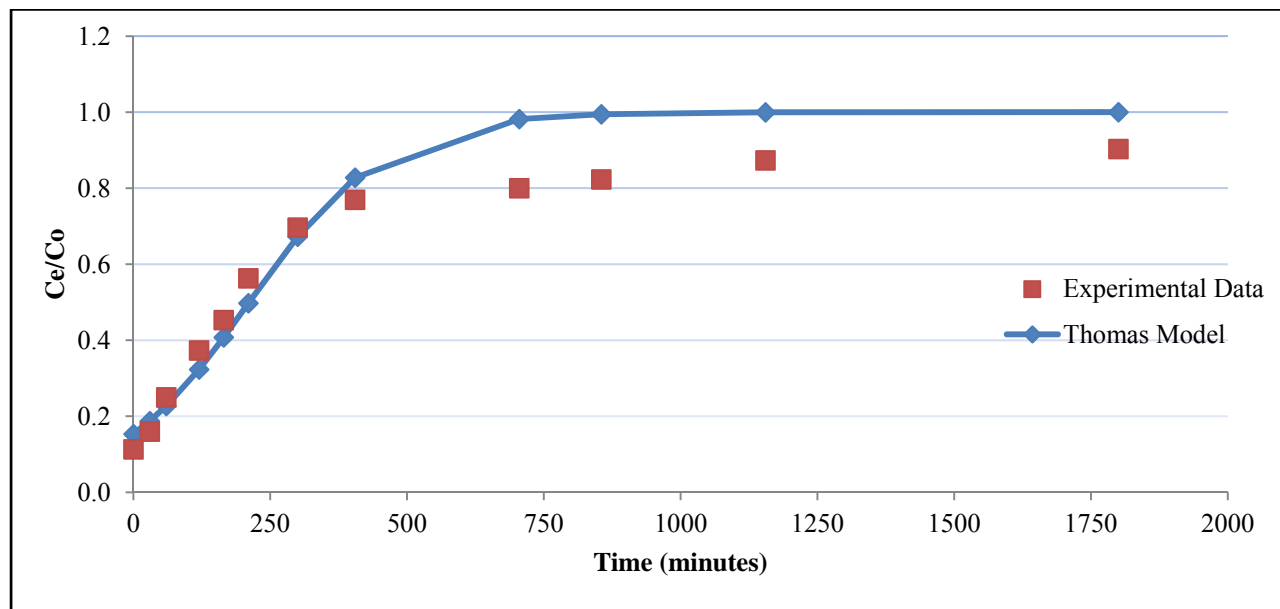

Figure 4-13 Thomas Model of Breakthrough Column with BAM nutrient mix 3-2 Using Initial PO_4 Concentration of $1 \text{ mg}\cdot\text{L}^{-1}$ and Flow Rate of $0.167 \text{ L}\cdot\text{hr}^{-1}$. Experimental data are the average effluent concentrations of the three columns

Table 4-14 is the summary data for the equilibrium absorbance uptake (q_0) of each of the column test data using the plot of $\ln[(C_0/C_e) - 1]$ vs. t (Figure 4-8; Figure 4-9; Figure 4-10). The column subjected to the shortest HRT and the lowest influent concentration evidenced the least amount of absorbance per gram of media ($0.000143 \text{ mg}\cdot\text{g}^{-1}$). On the other hand, the column subjected to the longest HRT and the highest influent concentration evidenced the greatest amount of absorbance per gram of media ($0.000534 \text{ mg}\cdot\text{g}^{-1}$). These are important values for the calculation of the total removal capability for a given mass of media.

Table 4-14 Thomas model equation for orthophosphate adsorption on abiotic nutrient adsorption media

Flow rate (ml·min ⁻¹)	Residence Time (min)	C _o (mg·L ⁻¹)	Regression Equation	R ²	K (mL·min ⁻¹ ·mg ⁻¹)	q _o (mg·g ⁻¹)
8.817	18	1.0	y = 2.186 - 0.0471x	0.99	47.1	0.000372
8.817	18	0.5	y = 1.202 - 0.0338x	0.98	67.6	0.000143
2.78	60	1.0	y = 1.709 - 0.0081x	0.95	8.10	0.000534

*Where $y = \log(C_o/C_e - 1)$ and $x = kC_oV/Q$

In the isotherm tests, BAM had more contact with the orthophosphate solution, maximizing the exposure of adsorption sites than in the columns where short-circuiting was the probable cause. From the propriety data for isotherms developed by a NELAC certified laboratory (Environmental Research and Design, Orlando), the adsorption equilibrium (q) values for C_o= 0.5 and 1.0 mg·L⁻¹ were 0.11 and 0.34 μg·g⁻¹ found for naturally occurring clay, respectively. These results compared reasonably with the experiments on adsorption equilibrium (q) values for C_o= 0.5 and 1.0 mg·L⁻¹, which were 0.143 and 0.372 μg·g⁻¹, respectively, for the breakthrough column tests using an 18-minute residence time in the column.

The conclusion from the test results showed that BAM Nutrient mix 3-2 was efficient and effective for phosphorus removal even at shorter residence times. In addition, the P removal via the sorption media was mostly a physiochemical process, although the process could change if the biofilm had more time to develop. The design of the baffle box assumed a flow-through condition; therefore, flow-through column studies are more representative of the adsorption kinetics of the media and the maximum equilibrium adsorption.

The column results were fitted to first and second order reaction rates the form $\ln(C) = -kt + \ln(C_o)$ and $1/C = 1/C_o + kt$, respectively. The Thomas Model assumes second-

order reversible reaction kinetics. The correlation was poor as judged by the first and second order reaction rates.

Table 4-14 shows the greatest reaction rate coefficient for the Thomas Model when q_0 had the least value. The “goodness of fit” was determined by fitting the data by the Thomas Model and a first order reaction. The results of the fit determined that the reaction rate, K was the greatest under conditions having the least influent concentration and least retention time.

4.4.4. Statistical Analysis of Results

Figure 4-11 and Figure 4-12 show the ANOVA used to determine the difference between adsorption curves created by the manipulation of the breakthrough columns with differing influent concentrations ($0.5 \text{ mg}\cdot\text{L}^{-1}$; $1.0 \text{ mg}\cdot\text{L}^{-1}$). The parameter representing intercepts of the lines were significantly different ($p = 0.00116$) when compared and fitted to the linear model to determine the significance of the influence concentration, which suggest that the intercept of the column adsorption curves differ between the two influence concentrations of $0.5 \text{ mg}\cdot\text{L}^{-1}$ and $1.0 \text{ mg}\cdot\text{L}^{-1}$. However, the slope parameters representing the slope of the line fit ($p = 0.089$) does not differ significantly at the 95% confidence level between two differing influent concentrations. This translates to the conclusion that differing the orthophosphate breakthrough column curves with influent concentrations $C_0 = 0.5 \text{ mg}\cdot\text{L}^{-1}$ and $C_0 = 1.0 \text{ mg}\cdot\text{L}^{-1}$ were significantly different at the y intercept, when $t = \text{zero}$. The slope at which the curves changed with time between these curves was not significantly different. The adsorption of orthophosphate between differing concentrations but the same residence time will initially adsorb at significantly different ($p < 0.05$) concentrations. However, the rate at attaining the maximum equilibrium adsorption capacity does not differ at the 95% confidence level between the columns.

The parameters representing the intercepts of the curves created by manipulative residence time, 18 minutes vs. 60 minutes, respectively (Figure 4-11 and Figure 4-13), were not significantly different (ANOVA $p = 0.8898$). This suggests that the intercept of the column adsorption curves do not differ between the two residence times, 18 and 60 minutes. The parameters representing the slope at which the curves changed ($p = 1.46 \times 10^{-13}$) differed significantly ($P < 0.05$) at the 95% confidence level between two retention times. This indicates that residence times of 18 minutes and 60 minutes of the orthophosphate solution in the column will cause a significant difference in the adsorption breakthrough curves created. The slopes of the curves (Figure 4-11 and Figure 4-13) differed significantly but not at the respective y-intercept, when $t = \text{zero}$. This suggests adsorption of orthophosphate between two residence times of 18 and 60 minutes does not differ in the amount it initially adsorbed when time = zero. However, it significantly differed ($p < 0.05$) in the rate at which the curves reached the maximum equilibrium adsorption capacity at a 95% confidence level.

4.5 REMARKS

It is a general understanding that nutrients are one of the most problematic pollutants, posing human and ecological health risks. To mitigate this issue, a literature review and isotherm tests of BAM Nutrient mix 3-2 proved to be more effective in adsorbing the nutrients. After conducting isotherm tests to fit the Langmuir and Freundlich models, the calculated maximum equilibrium adsorption for an influent concentration of $1.0 \text{ mg}\cdot\text{L}^{-1}\text{-P}$ at a residence time of 1.0, and 0.5 hours were $1.405 \text{ }\mu\text{g}\cdot\text{g}^{-1}$ and $1.228 \text{ }\mu\text{g}\cdot\text{g}^{-1}$, respectively. These values demonstrate a significant removal. These values increase with extended contact time as determined by further investigation using sorption column tests. Column tests data fitted to the

Thomas Model to investigate the amounts of removal under varying contact time in the column and influent concentrations showed good correlation ($R^2 = 0.9876$; 0.9839 ; and 0.9501). Adsorption equilibrium uptake (q) values for $C_0 = 0.5$ and $1.0 \text{ mg}\cdot\text{L}^{-1}$ were 0.143 and $0.372 \text{ }\mu\text{g}\cdot\text{g}^{-1}$, respectively for the breakthrough column tests under an 18 minute residence time in the column. The statistical analysis of the columns suggested that the influent concentrations changed the initial amount at which the adsorption started, but manipulation of the residence time within the columns changed the rate at which adsorption in the column occurred.

CHAPTER 5: TESTING OF SORPTION MEDIA FOR NUTRIENT REMOVAL USING STORMWATER CONDITIONS

5.1 INTRODUCTION

Information in this chapter further addresses the removal of nutrients potentially caused by constituents in runoff water found in wet detention ponds. Additional investigations of pond characteristics that include chemical and biological mechanisms are important because the natural chemical and biological treatment processes for removing contaminants are usually more sustainable than laboratory-derived chemical and physical methods that uses distilled water (Gavrilescu and Chisti, 2005). This chapter presents experiments conducted to observe expected improved physiochemical removal of phosphorus concentrations using actual pond water fed primarily from stormwater runoff. Researchers expect that the removal is an indication for the presence of elements that assist in chemical precipitation when using pond water. Furthermore, the experiments conducted were to determine if biological P removal begins and how the sorption media functions when there is no flow present, and if effective biological removal of nitrogen species occurs.

Initially, the sorption media acted as a sorbent for each chemical species that reacted physically and chemically with those sorbents until the media reaches equilibrium and the saturation of the media is complete. Adsorption-desorption processes mostly determine the concentrations of inorganic-P in solution over a short period, followed by the influences of solid-state diffusion, precipitation-dissolution, and immobilization mineralization over longer periods (Murrman and Peech, 1969). The chemical and physical forces of surface interactions, London-van der Waals, may achieve attachment and adsorption by surface hydration of ions, steric interactions of adsorbed macromolecules, the interaction of hydrophobic surfaces, and ionic or

covalent bonding (Tobiason and O'Melia, 1988; Benjamin, 2002). The compounds found in pond water allows a much great orthophosphate removal rate by aiding adsorption in phosphate removal, and influencing diffusion, precipitation, and mineralization.

The phosphate concentration in solution is a function of diffusion rate, which regulates the soil surface reactions affected by the properties and concentrations of ions in the soil. Barber *et al.* (1984) found the diffusion of phosphate ions was much lower in soil than in free water, because the lower the nutrients diffusion coefficient, the greater the reduction in concentration at the surface. Therefore, the ions found in pond water regulate and facilitate diffusion of phosphorus into sorption media. These ions found suspended in the water column also function to precipitate the phosphate, which may be either reactively filtered or inertly filtered as particle bound pollutants via sedimentation, straining, and depth filtration (Crittenden, 2005). The precipitation of phosphate is usually as Fe and Al phosphates in acidic soils and as Ca and Mg phosphates in alkaline and calcareous soils (Sample, 1980). The fractionation of inorganic P can be in three distinct classes of compounds, explicitly phosphates of Fe, Al, and Ca.

After the occurrence of maximum adsorption and development of a biofilm, the nutrients removal by chemical and biological removal processes continued. There are several key chemical reactions, which define the removal of nitrogen species by biological processes. In this processes, ammonia oxidizes to nitrite and nitrate as shown below (Sawyer *et al.*, 2003):

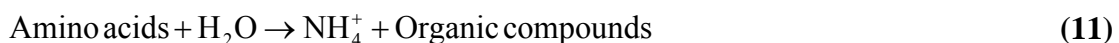

After the oxidation, denitrification proceeds to reduce nitrate to nitric oxide or nitrogen gas with the use of a carbon source, such as $C_{10}H_{19}O_3N$, as an electron donor (Sawyer *et al.*, 2003).

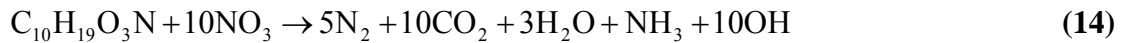

The rate of adsorption of the contaminants by the biofilm is dependent on diffusion processes within the biofilm, influenced by its water-binding capacity and mobility (Singh, 2006). In terms of nutrient adsorption, organisms within the biofilm require a continuous supply of nutrients for growth, so the diffusion process of these nutrients may not be limiting. Approximating the amount of nutrient adsorption using the chemical formula $C_5H_7NO_2$ for cell biomass, yields approximately 12.4% by weight of nitrogen required; and typically, the amount of phosphorus required by the organism is one-fifth of the nitrogen value (Metcalf & Eddy *et al.*, 2003). However, these uptake quantities vary depending upon the solids retention time (SRT) and environmental conditions of BAM media (Hossain *et al.*, 2009). Further investigation of this variation of biological nutrient uptake is dependent upon HRT, and requires the weekly conduct of batch reactor tests to determine the varying nutrient removal efficiencies of the biofilm under 6-, 12-, and 24-hour retention times. Biological processes could achieve the regeneration of the biosorption media in a more cost-effective, low energy, and low maintenance solution than media replacement or chemical regeneration alternative of the sorption media.

Aluminum, calcium, iron, and magnesium assist in the precipitation of phosphorus. In 39 Florida lakes, Putnam *et al.* (1972) reported concentrations of these elements. Known for these elements and their compounds are simple precipitation reactions. However, alkalinity, pH, trace metals, and equilibrium constants may produce variability in the estimates. The efficiency of

removal via coagulation and precipitation decreased with a decreasing phosphorus concentration.

Below are the list of precipitation reactions of elements calcium, aluminum, iron, and magnesium

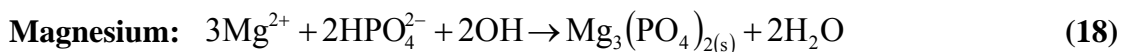
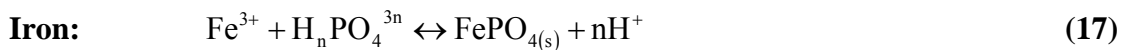
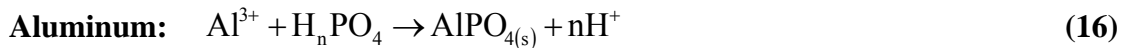
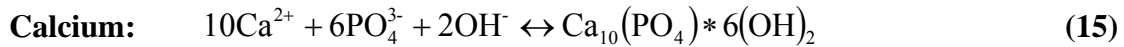

Biofilms are congregations of single or multiple populations attached to surfaces by their extracellular polymeric substances. The use of biofilms and biological remediation strategies in multiple treatment systems are because of their ability to remove and immobilize a variety of contaminants. The use of an attached biofilm establishment was a more proficient choice of bioremediation in this application because of a better chance of adapting and surviving in their matrix protection than planktonic, free swimming organisms (Decho, 2000). This matrix created also functions to further the filtration of the influent stormwater.

The ability for microorganisms to absorb metal ions [Fe(III) and Cr(VI)] was dependent on metal concentration, pH, temperature, growth media composition, culture age, and contact time (Goyal *et al.*, 2003).

The previous information determined the maximum orthophosphate adsorption in the columns: however, distilled water is not used. With distilled water, the columns reached maximum adsorption in less than two days. This also verifies the results in chapter 3. The first phase of continuing sorption work without distilled water is to determine the effects of using

pond water in adsorption breakthrough columns. The introduction of pond water may change other environmental factors that affect adsorption, such as pH (Hossain *et al.* 2009).

During the continuous column operation, the flow was paused after 10 days, 17 days, and 24 days to evaluate the batch flow. The objectives for the paused flow were to determine the removal efficiencies during simulated non-flow events and consequent effects on the continuous mode. After chemophysical adsorption, the influent water, the water was resident in the column for 6, 12, and 24 hours to test BAM's biological effects of nutrient removal. The assumption after the first day was that removal was a function of biological and chemical processes. Pausing of flow in the column operation was to understand nitrifying and denitrifying bacterial activity across the sorption media, given that the substrate and enzymes were not the limiting factors with respect to nitrogen removal.

The hypothesis in the experiment was that the use of pond water would increase orthophosphate removal and balance media uptake when compared to values found using distilled water. The presumption was that the increase in removal increase was due to the increased ions and elements, such as Ca, Mg, Al, and Fe in pond water. The complimentary biochemical mechanisms of the elements within pond water and structure of the media was presumed to facilitate removal by adsorption, diffusion, precipitation, and mineralization, of which the largest contributor may be calcium, found at high concentrations in the pond water (around $25 \text{ mg}\cdot\text{L}^{-1}$). These elements and bacteria in the pond water would assist in providing ecological conditions necessary for beneficial organisms to inhabit. If an aerobic-anoxic sequence was established within the column, the hypothesis that biological removal of ammonia and nitrate would be evidenced in the effluent concentrations of each chemical due to the establishment of nitrifying and denitrifying bacteria on the BAM.

5.1.1 Science Questions

What competition effects do pond water elements have on the physiochemical adsorption ability of phosphorus? Will the population dynamics of nitrifying and denitrifying bacteria regenerate the nutrient sorption media after physiochemical sorption has occurred? When does the biological removal and uptake processes begin occurring and at what nutrient removal rates?

5.1.2 Objectives

The objectives for chapter 5 were to:

- Operate column tests using pond water with roadway runoff concentrations from UCF's Pond H-2 to test effluent concentrations of orthophosphate, total phosphorus, total nitrogen, ammonia, and nitrate
- Apply the Thomas Model to the columns to calculate the maximum adsorption equilibrium uptake (q) value and adsorption constant (K_T).
- Compare the results with those found the previous chapters.
- After 10 days, and every five-day intervals following, conduct a batch reactor test on the columns for residence times of 6, 12, 24 hours. These batch tests simulated inter storm events to determine continuous removal after longer residence time in the column.
- Analyze Scanning Electron Microscope (SEM) pictures from samples taken throughout the column testing.

5.2 METHODOLOGIES

5.2.1 Column Tests

Three Plexiglas columns with a diameter of 5.08 cm (2.0 inches) and a length of 30.48 (1.0 ft.) were prepared with 1100 g of dried BAM Nutrient mix 3-2 and a filter placed at the bottom to prevent the outward flow of finer particles and glass beads. In addition, a second filter placed at the top was to assist dispersion. The columns were covered and the lights kept off to simulate conditions within the baffle box and prevent the growth of photosynthetic organisms.

For a microorganism to grow, reproduce, and function properly, sources of energy, oxygen conditions, carbon, and inorganic elements are required. These principal inorganic elements required by microbial life include N, S, P, K, Mg, Ca, Fe, Na, and Cl with the primary nutrients being nitrogen and phosphorus (Metcalf & Eddy *et al.*, 2003). Therefore, if a biological system is to function properly, a sufficient amount of nutrients and trace elements required by the microorganisms must be present. For this reason, the nutrients in the runoff water were increased. Pond H-2 water on UCF's campus was used to simulate runoff. The pond is a eutrophic pond. This water used for testing allowed the growth of a biofilm. The microbiological organisms and organic matter within the effluent added to the effluent concentrations, thus a 0.45- μm membrane filter to remove particulates and stabilize the nutrient concentrations. Filtering of the effluent samples was required. Pumped into the media was spiked pond water from UCF's pond H-2 to a final PO_4 , NO_3 , and NH_3 concentrations of 1.0, 0.5, and 0.5 $\text{mg}\cdot\text{L}^{-1}$, respectively.

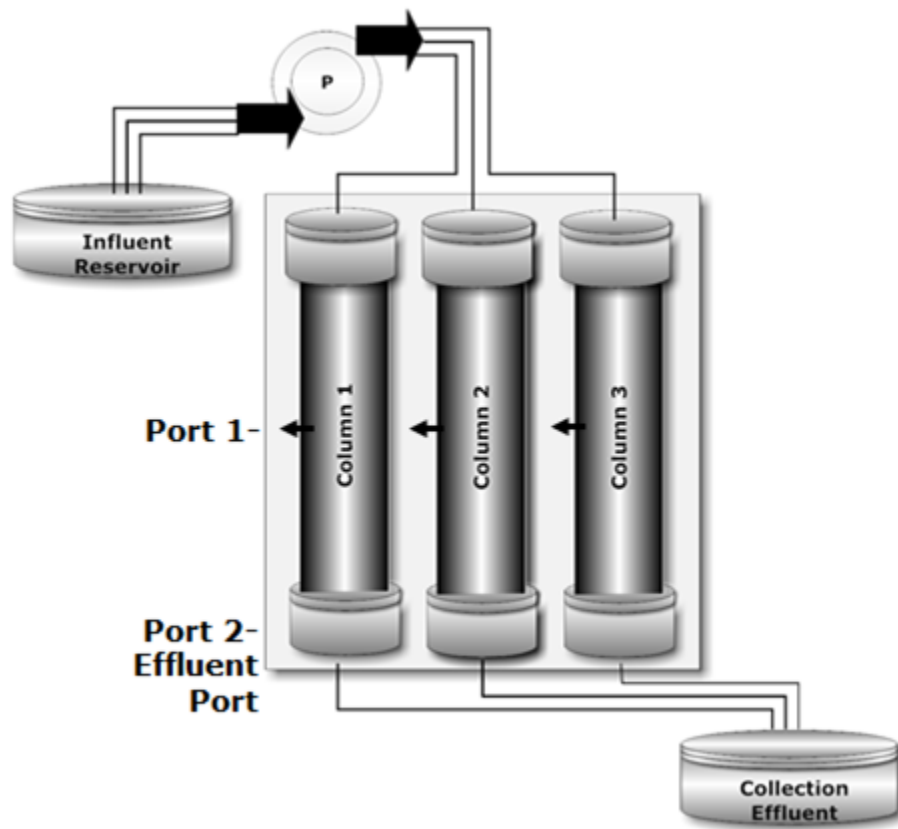

Figure 5-1 Experimental Setup of the Biological Testing

In the continuous flow mode of this experiment, the columns flowed at a rate of $0.167 \text{ L}\cdot\text{hr}^{-1}$ (1.0 hour residence time). Chemophysical adsorption of the column's media was expected reach equilibrium within the first several hours based on the results from chapter 4. During this timeframe, there were frequent sampling of the effluent to obtain the adsorption breakthrough curve of all the nutrients, and the influent in case of any changes in influent concentrations. After the columns had reached equilibrium, there was assumption that the media had reached maximum adsorption via its physical and chemical properties and any further removal was due to the biological uptake. Values from the column experiment fitted to the Thomas model was to determine the maximum equilibrium media uptake. Shown below is the expression:

Linear Form:
$$\frac{C_e}{C_o} = \frac{1}{1 + \exp\left[\frac{1}{K_T}(q_o m - C_o V)\right]}$$
 (19)

Non-linear Form:
$$\ln\left(\frac{C_e}{C_o} - 1\right) = \frac{K_T q_o m}{Q} - \frac{K_T C_o V}{Q}$$
 (20)

where C_e = Effluent Concentration ($\text{mg}\cdot\text{mL}^{-1}$); C_o = Influent Concentration ($\text{mg}\cdot\text{mL}^{-1}$); K_T = Kinetic Coefficient ($\text{mL}\cdot\text{mg}^{-1}\cdot\text{min}^{-1}$) q_o = equilibrium media uptake ($\text{mg}\cdot\text{g}^{-1}$) (when $C_e=C_o$); m = Total media mass in the column (g); Q = Volumetric flow rate ($\text{mL}\cdot\text{min}^{-1}$); and V = Throughput volume (mL). Found in the literature are additional information on the calculation of the Thomas Model equations and methods (Mustafa and Ebrahim, 2010).

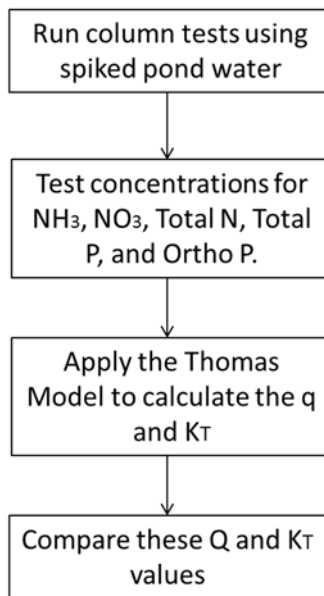

Figure 5-2 Phase 1 of Testing to Determine the Physiochemical Equilibrium Adsorption Capacity and Kinetics. This investigates the initial physiochemical adsorption of the media using spiked pond water

5.2.2 Batch Tests

Figure 5-3 shows the flow chart for the batch mode of this experiment. The column testing ran continuously for 10 days, after which the flow was paused and the column filled to the top of the media. The residence times for pond water in the column were 6, 12, and 24 hours. The experiment then flowed for a week and the batch test repeated again on a weekly basis. Analyzed were effluent samples for TP, PO₄, NO₃, NH₃, and TN. Used was a Hach probe for pH measurements. Table 5-1 presents the methods used for all chemical analyses. Used was a 0.45 μm filter for Ortho-P, ammonia, nitrate, and TN values.

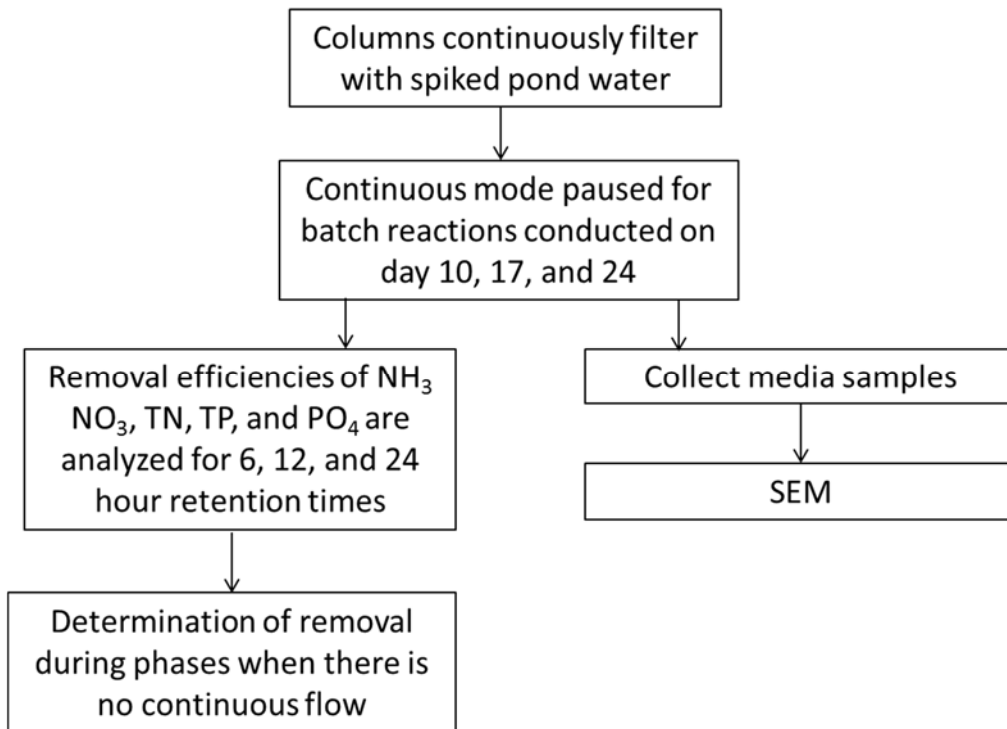

Figure 5-3 Phase 2 of Biological Testing to Determine the Biological Growth and Kinetics of the Developing Biofilm. This Involves the Continuous Run and Batch Tests with SEM

Table 5-1 Methods used to analyze concentrations of each chemical

Chemical species	Title of Method	Method no.	Measuring range (mg·L ⁻¹)
Ammonia-N	Low range salicylate method	Method 10023	0.02-2.50
Nitrate-N	Cadmium reduction method	Method 8171	0.1-10.0
Orthophosphate-P	USEPA PhosVer®3 (ascorbic acid) method	Method 8048	0.02-1.60
Total Nitrogen-N	Persulfate digestion method	Method 10071	0.5-25.0
Total Phosphorus-P	USEPA PhosVer®3 acid persulfate digestion method	Method 8190	0.02-1.10

5.2.3 Statistical Analyses

To determine whether the adsorption curves generated by Figure 5-6 and Figure 4-13 are significantly different from each other because of the use of different water sources – distilled and pond water – the data fitted to a linear model and evaluated with a t-test statistical analysis. Figure 4-10 and Figure 5-4 present the linearized plot of the raw data from each column by plotting $\ln[(C_o/C_e) - 1]$ vs. t . to fit the linear model. The linear model used for comparison analysis is

$$\hat{Y} = \beta_0 + \beta_1 * Time + \beta_2 (WaterSource = Pond) + \beta_3 (WaterSource = Pond) \quad (21)$$

where $\hat{Y} = \ln((C_o/C_e) - 1)$ and $(WaterSource = Pond)$ is an indicator variable that takes on the value 1 when the *Water Source* is "Pond" and takes on the value 0 when the *Water Source* is not "Pond". Each analysis was considered significant at a confidence interval of 95% ($\alpha=0.05$). Statistical analyses performed using R statistical software were to define variability in orthophosphate removal. The linear model used the prediction for \hat{Y} with “pond” water source as

$$\hat{Y}_{PondWater} = \beta_0 + \beta_2 + (\beta_1 + \beta_3) * Time$$

The prediction for \hat{Y} without “pond” water source as

$$\hat{Y}_{DistilledWater} = \beta_0 + \beta_1 * Time$$

Table 5-2 presents the parameters of the Thomas model derived from the linearized plots.

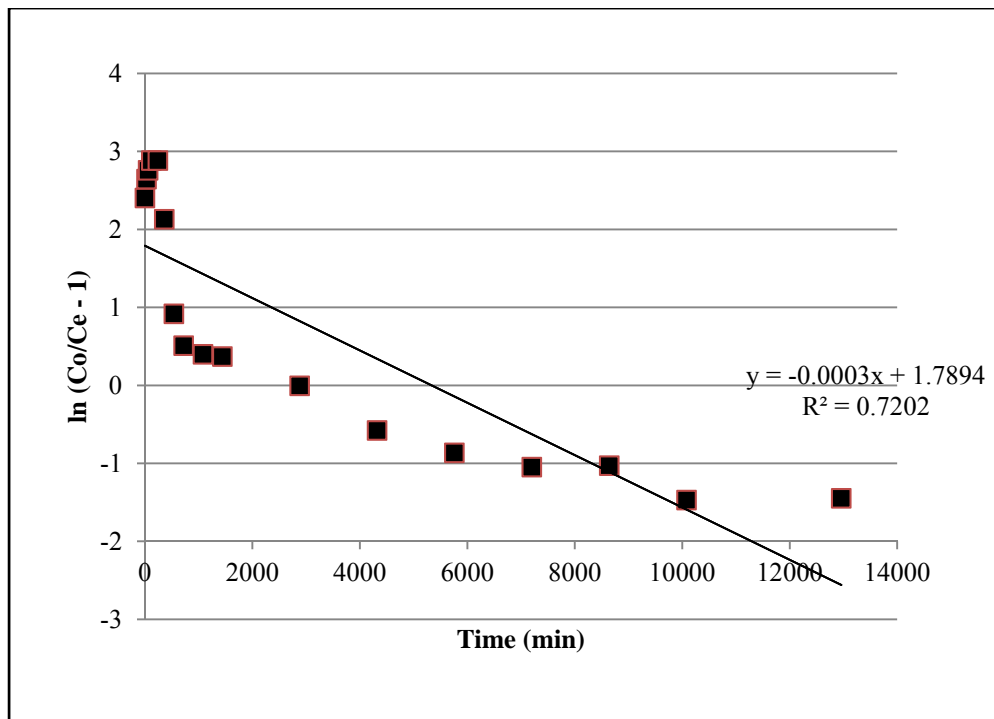

Figure 5-4 Plot of $\ln(C_o/C_e - 1)$ vs. time for BAM Nutrient mix 3-2 using spiked phosphorus pond water with an initial PO_4 concentration of $1.0 \text{ mg}\cdot\text{mL}^{-1}$ and flow rate of $0.167 \text{ l}\cdot\text{hr}^{-1}$ used to derive values for the Thomas Model

Table 5-2 Parameters of the Thomas Model derived from the plot of $\ln(C_o/C_e - 1)$ vs. time

q =	$0.0150743 \text{ mg}\cdot\text{g}^{-1}$
Kt =	$0.3 \text{ ml}\cdot\text{min}^{-1}\cdot\text{mg}^{-1}$
C_o =	$0.001 \text{ mg}\cdot\text{mL}^{-1}$
Flow Rate =	$2.78 \text{ ml}\cdot\text{min}^{-1}$
m =	1100 g

For a two tailed t- test, the hypothesis for the analysis to determine the intercepts is that the null hypothesis $H_0: \beta_0 = 0$; and the alternate hypothesis is $H_1: \beta_0 \neq 0$. The interpretation of the resulting p-value was that there were not enough evidence to reject the null hypothesis and the intercept of the regression line was not different from zero. This corroborated the researchers' expectations because both types of water began with the same initial concentration of orthophosphate. To test for a difference in the slope of the distilled water regression line and the pond-water regression line, a hypothesis test performed had a null hypothesis that β_3 is equal to zero. In the statistical test, β_3 represents the difference in slope between the two water types. If β_3 is equal to zero, there is no difference in the slope of the best fitting line for the two water types. These results will indicate if there is significant differences in the slope and intercept of the orthophosphate adsorption curves (Figure 4-13 versus Figure 5-6) generated by changing the residence time within the column for the use of distilled water and pond water from pond H-2.

5.2.3 Scanning Electron Microscopy (SEM)

The use of the Scanning Electron Microscopy (SEM) shown in Figure 5-5 was to provide visual observations of microbial growth and biofilm development. This type of microscopy produces 3-dimensional images of a sample's surface using a focused beam of electrons accelerated to high energy and focused on the sample while the specimen is in a high vacuum. Secondary electrons ejected from the sample surface allows for the visualization of the biofilm, pore structure, and other surface characteristics. The SEM images provided visual observation of the surface texture and development of a biofilm throughout experimentation. Removed from the top and from the sampling port of the column was approximately one gram of media using metal prongs. The UCF's Materials Characterization Facility used a JEOL JSM-6480 SEM for the analyses of samples from the columns.

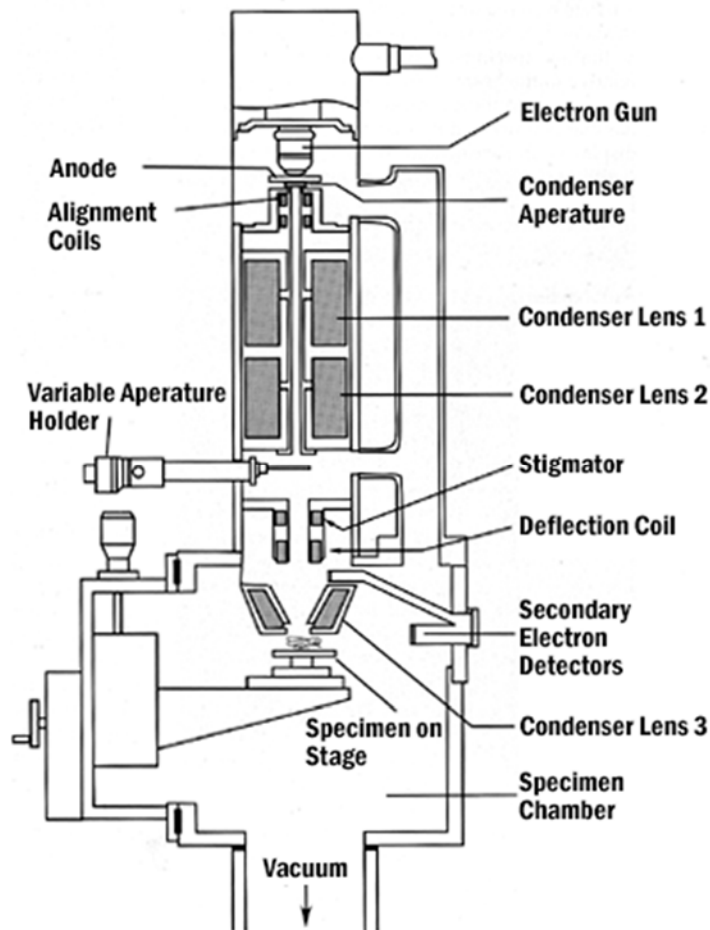

Figure 5-5 Schematic Drawing Scanning Electron Microscopy (University of Iowa, 2013)

5.3 RESULTS AND DISCUSSION

5.3.1 Thomas Models

Figure 5-6 shows the results of the orthophosphate spiked pond water column test fitted into the Thomas Model Figure 5-6 to determine BAM’s maximum equilibrium adsorption under the described conditions. Calculations to determine the maximum adsorption equilibrium (q) and K_T were obtained by first plotting $\ln(C_o/C_e - 1)$ vs. time (Figure 5-4) for the first 12,960 minutes, which yielded a R^2 correlation of 0.7202. This low correlation compared to the results

from distilled water is most likely due to the addition interferences of adsorption and ion exchange.

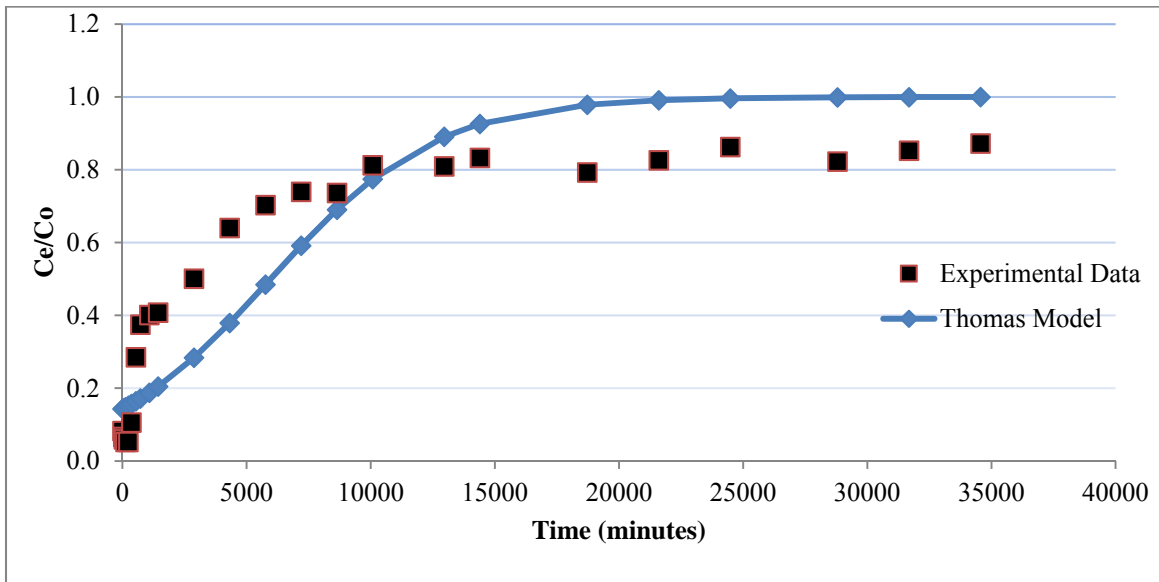

Figure 5-6 Thomas Model of Breakthrough Column with BAM Nutrient mix3-2 Using Initial PO_4 Concentration of $1 \text{ mg}\cdot\text{mL}^{-1}$ and Flow Rate of $0.167 \text{ L}\cdot\text{hr}^{-1}$. Experimental data are the average effluent concentrations of the three columns

Much greater orthophosphate removal occurred in this study when compared to results using distilled water and under the same conditions using only a phosphorus solution. The use of a phosphorus solution with distilled water yielded a maximum adsorption equilibrium (q) of $0.000533 \text{ mg}\cdot\text{g}^{-1}$. For the experiment that used pond water under the same conditions, the maximum adsorption equilibrium (q) was $0.0151 \text{ mg}\cdot\text{g}^{-1}$. The maximum adsorption amount found with pond water is about 30 times greater than without pond water. The pond water used was mostly from runoff water with minimal groundwater input. This emphasizes the additional removal due to compounds in the pond water that have an effect on the orthophosphate adsorption of this media.

The average conductivity of the spiked pond water was about 233 $\mu\text{S}/\text{cm}$, while the spiked distilled water had a range of 0.5 – 5.0 $\mu\text{S}/\text{cm}$. More ions were in the spiked pond water, assisting with removal. Ions found in pond water function to regulate and facilitate diffusion of phosphorus into sorption media, which regulates the concentrations and ions. These ions may also assist in the precipitation of phosphorus. The pH of the spiked influent pond water was in the range of 7.0 to 7.2. The statistical analysis concluded that the initial effluent concentrations and adsorption ability at the beginning of the experiment was not different between the use of pond and distilled water, but there was significant difference in the rate that it was adsorbed at a 95% confidence level.

Figure 5-6 shows that the experimental data never reached the equilibrium with the influent concentration. Although the column most likely reached its sorption capacity by the end, phosphorus precipitation and filtration were likely the cause of the removal. Table 5-3 presents the concentrations of the Fe, Al, Ca, and Mg elements in the influent pond water. Calcium concentrations of 23.8 $\text{mg}\cdot\text{L}^{-1}$ in the influent water were very high when compared to the concentration ranges of 7.08 to 0.10 $\text{mg}\cdot\text{L}^{-1}$ found in Florida lakes by Putnam *et al.* (1972). These results indicate that phosphorus precipitation and fractionation most likely occurred, which contributed to the phosphorus removal. The media might have trapped the precipitated phosphorus via filtration.

Table 5-3 Concentrations of Aluminum, Calcium, Iron, and Magnesium in Influent Pond Water

Parameter	Concentration ($\text{mg}\cdot\text{L}^{-1}$)	Method
Aluminum	0.422	EPA200.8
Calcium	23.8	EPA200.7
Iron	0.276	EPA200.7
Magnesium	2.26	EPA200.7

Total phosphorus appeared to follow the same removal trend as orthophosphate, although in the batch reactions, there was a much greater increase in the difference between total and ortho-phosphorus. This is most likely due to the greater residence time in the column, which allowed for more chemical precipitation and biological removal of phosphorus. There were observations of chemical precipitation after the adsorption peak leveled off and the column had been running for about 20 days, which consistently continued to remove 10% of the orthophosphate. This reinforces the instant adsorption followed by chemical precipitation such that the rate of reaching phosphate equilibrium between solution and solids showed a relatively rapid initial reaction rate followed by a slow, continuous reaction for an extended time (Barrow and Shaw 1975). The discrepancy of the experimental data showing less removal than the predicted Thomas Model in the first 10,000 minutes (Figure 5-6) may be due to competitive adsorption of the other elements present in the pond water competition for similar adsorption sites. Another explanation for discrepancy may be the decreased correlation ($R^2 = 0.7202$, Figure 5-4) and fitting to the Thomas Model because the phosphorus removal was not purely due to adsorption.

5.3.2 Batch Test Results

Table 5-4 shows that the pausing of continuous flow by the batch tests had no obvious effect on the adsorption curve for continuous mode. Therefore, by pausing the flow or pump in a filter box, the media was not necessarily rejuvenated nor was the removal efficiency for the continuous flow treatment affected. The removal of orthophosphate in the batch mode appeared to match about the same removal that occurred on the continuous mode (Figure 5-11).

Comparing the residence time in the column to orthophosphate, it was apparent that there were consistently more ortho-P removal at 6 hours than at 24 hours residence time. This indicates that desorption or other chemical mechanisms would start to interfere with uptake at a 12 and 24 hours residence time. If biological P uptake were to occur, then there would be the expectation for greater removal of P at longer residence times, which was not the case. All of these trends found for orthophosphate were also consistent for total phosphorus.

Table 5-4 Results of Batch Reactions Conducted After Running the Column for 10, 17, and 24 Days

Number of Days Column Running	Residence Time (hour)	Ortho-phosphorus (mg·L ⁻¹)	Total Phosphorus (mg·L ⁻¹)	Ammonia (mg·L ⁻¹)	Nitrate (mg·L ⁻¹)	Total Nitrogen (mg·L ⁻¹)
10	24	0.73	1.04	0.76	0.17	3.30
	12	0.75	0.99	0.71	0.20	1.07
	6	0.64	0.94	0.38	0.20	0.83
17	24	0.86	1.13	0.74	0.17	2.47
	12	0.83	1.10	0.61	0.20	2.80
	6	0.81	1.02	0.38	0.20	2.33
24	24	0.90	1.00	0.56	0.20	3.50
	12	0.87	0.88	0.25	0.20	2.17
	6	0.85	0.87	0.16	0.20	2.67

Concentrations of ammonia found during the batch tests showed less removal of ammonia at longer residence times and increased levels than the initial concentrations. This is evidence of ammonification, the conversion of organic nitrogen present in the pond water to ammonia. The greatest removal of nitrate occurred during this batch reaction, where effluent NO₃ concentrations were consistently at concentrations of 0.2 mg L⁻¹ or less. This may be due to the increased anoxic zone that occurred because of the stagnant water in the column.

5.3.3 Statistical Analysis

The fitting of the curves of Figure 5-6 and Figure 4-13 to the linear model was to determine the significance of water type. The parameters representing the slope of the lines were significantly different ($p = 1.954 \times 10^{-13}$), suggesting that the slope of the line fit representing rate of adsorption differs significantly between pond and distilled water. However, the parameter comparing the y intercept between the curves was found to not be significantly different ($p = 0.2315$). This implies the initial adsorption ability is not different between the use of pond and distilled water, but there is significant difference in the adsorption rate at a 95% confidence level.

5.4 SCANNING ELECTRON MICROSCOPY (SEM)

The SEM photos show the surface characteristics and structure of the materials, which serve as residence to the biofilm. There were no analysis conducted on limestone due to its primary purpose, which is serving as chemical precipitation. Although the determination of bacterial growth was not distinct, it is reasonable to conclude that certain components of the BAM mix provided more optimal growth environments for a biofilm. There was good amount of surface area because the components of the BAM mix were small, porous, and rough. Increasing the surface area increases the amount of adsorption (Faust and Aly, 1998) and the amount of bacteria growth on the surface (Donlan, 2002). For BAM mix 3-2, the surface area was $0.446 \text{ m}^2 \cdot \text{g}^{-1}$. Therefore, in a cubic foot of the media, there was $17,530 \text{ m}^2$ of surface area. The processes of adsorption and absorption occur at the surfaces of materials, thus, it is obvious that the surface area is one of the principal characteristics that determines the sorption capacity.

Micro-pores contribute a major portion of the surface area and significantly affect the sorption ability if the solute molecule is able to penetrate into the pore (Faust and Aly, 1998). The SEM photos of expanded clay in Figure 5-8 show evidence of these micro-pores. Although the shape and roundness of the media grains, often characterized as sphericity or shape factor, affect filtration efficiency (Faust and Aly, 1998), their value on the filtration is limited and other variables, such as porosity and flow rate, have more impact on design (Crittenden, 2005).

The surface structures characteristics are an imperative feature for the biofilm attachment process. As the roughness of a surface increases, the magnitude of biological colonization increases, due to the greater surface area and decreased shear forces on the surface (Characklis, 1990). This indicates that the tire crumb (Figure 5-9) and expanded clay (Figure 5-8) would create much more ideal attachment structures with shear protection than the cement sand (Figure 5-7). The exposure of the biofilm to greater turbulence and shear stress is possible if there were an increase in the flow velocity across the material surfaces and a decrease in the boundary layer. Therefore, for materials with more flat and non-rigid surfaces, such as sand, the biofilm may be more likely to detach under higher flow conditions. The material composition of tire crumb would also provide a better attachment structure because biofilms attach much more rapidly to hydrophobic, nonpolar surfaces such as plastics than to hydrophilic materials (Fletcher *et al.*, 1979; Pringle *et al.*, 1983). Tire crumb contains carbon black, which promotes biological growth because carbon is a crucial compound for denitrification. Carbon black is a paracrystalline carbon produced from the incomplete combustion of heavy petroleum products with a high surface area to volume ratio.

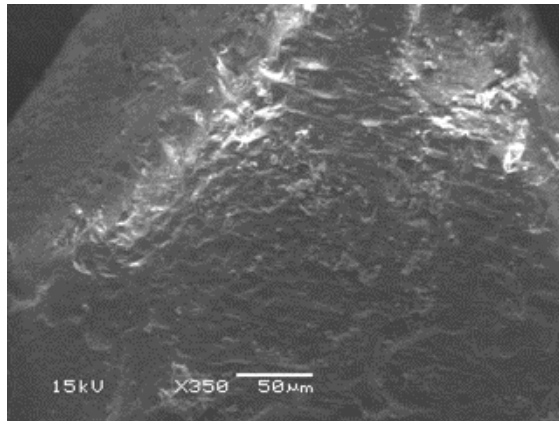

(a)

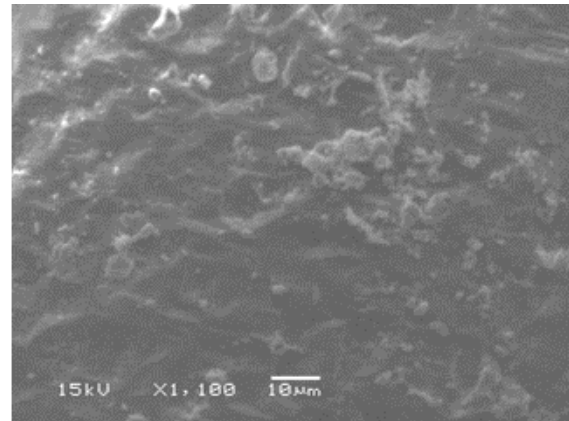

(b)

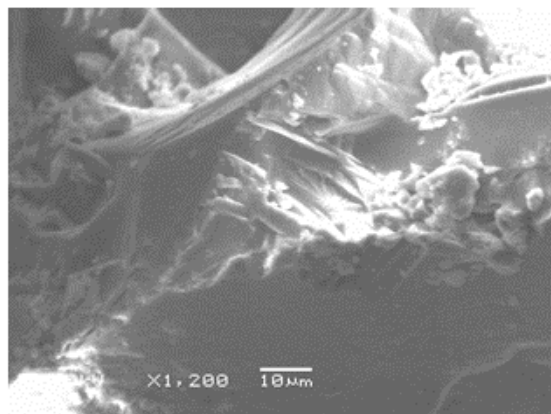

(c)

Figure 5-7 Concrete Sand shown in SEM at (a) 350 x, (b) 1,100 x, and (c) 1,200 x magnification showing the surface structure and characteristics after residing in the 24 days of column testing

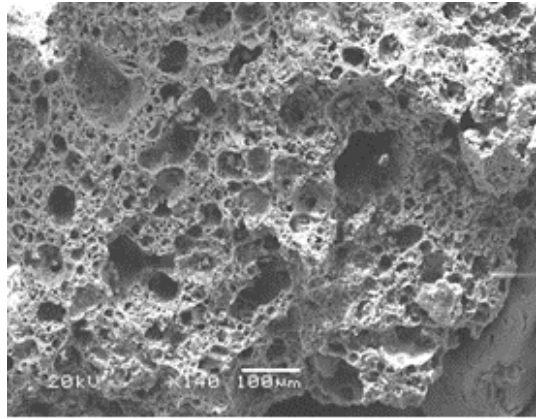

(a)

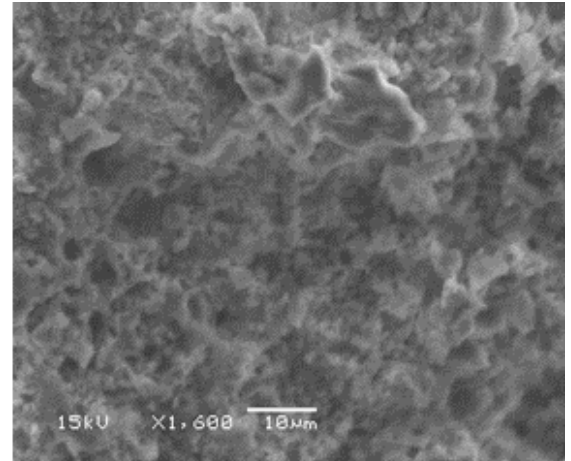

(b)

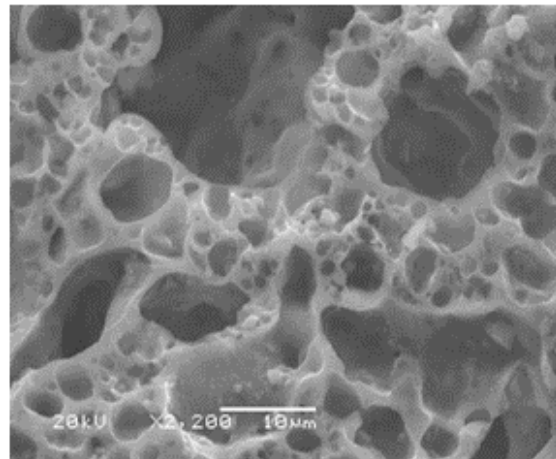

(c)

Figure 5-8 Fine Expanded Clay shown in SEM at (a) 140 x, (b) 1,600 x, and (c) 2,200 x magnification showing the surface structure and characteristics after residing in the 24 days of column testing

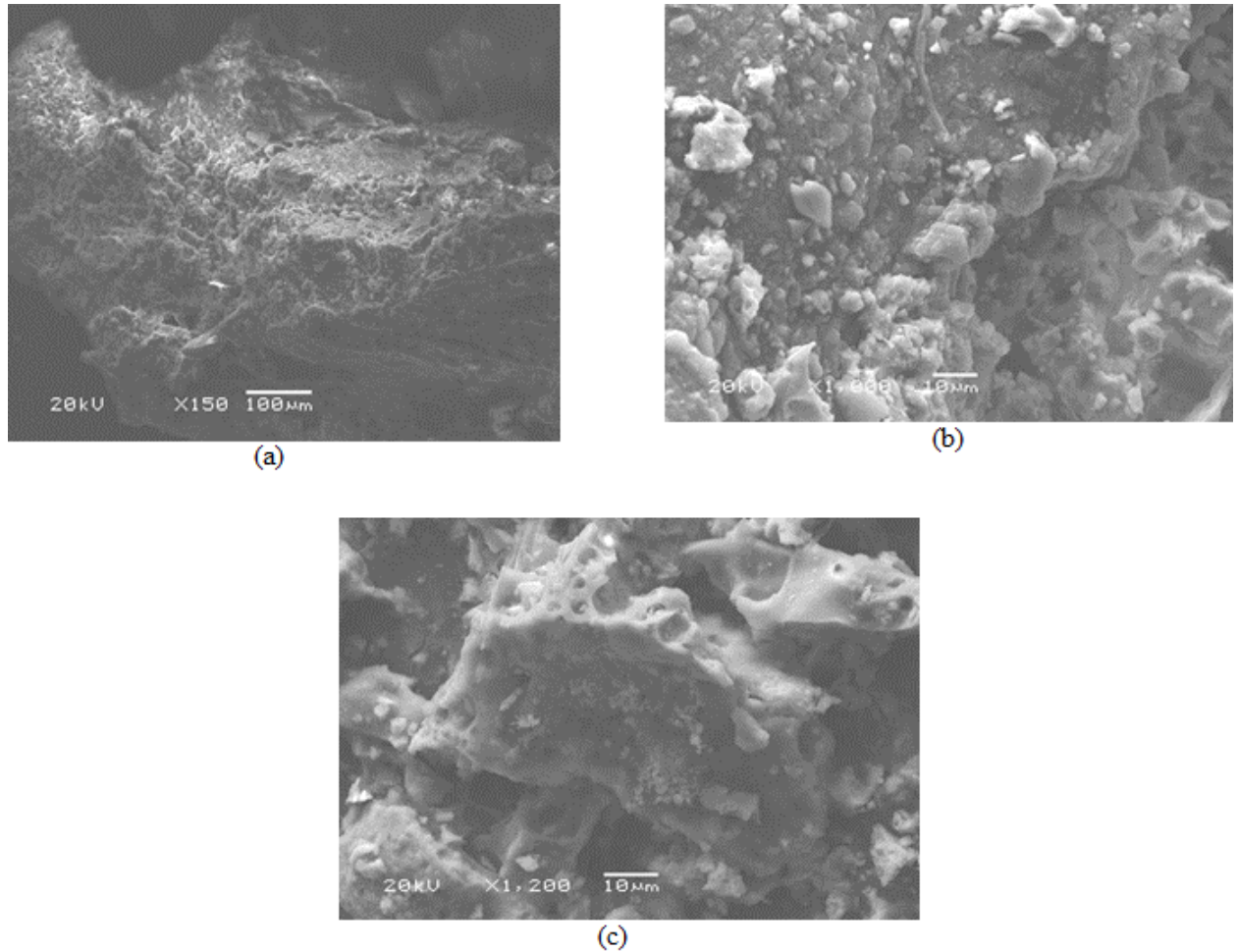

Figure 5-9 Tire crumb shown in SEM at (a) 140 x, (b) 1,600 x, and (c) 2,200 x magnification showing the surface structure and characteristics after residing in the 24 days of column testing

5.5 FACTORS AFFECTING BIOFILM

Although the nutrient removal media may show great removal efficiency, concern lies in the susceptibility of nitrogen-removing biofilm's bacterial colonies to anthropogenic input of other inorganic contaminants in stormwater runoff. Copper exposure had shown to change the structure, physiology, and metabolism of biofilms (Barranguet, 2002). Exposure of bacterial communities in biofilms were distinctively changed in denaturing gradient gel electrophoresis

profiles at concentrations of $6.8 \text{ } \mu\text{mol}\cdot\text{L}^{-1}$ copper (Boivin *et al.*, 2006). Biofilms are sensitive at such low levels of copper, thus, it is of great concern that the high concentrations found in stormwater runoff may have a significant decrease on the performance of the nitrogen reduction within the baffle box design.

Figure 5-10 presents the average effluent concentrations of all chemical species from the column tested. The adsorption of the orthophosphate and total phosphorus (Figure 5-11 and Figure 5-12) follow the same adsorption pattern previous seen in chapter 3. After 200 hours (8.33 days), the column was capable of removing 20% of the influent phosphorus concentrations. The removal leveled off for the following 400 hours (16.7 days). The chemical precipitation of P aids in the column never reaching zero % removal due to the elements in stormwater (Fe, Mg, Ca) and the limestone (CaCO_3), which removes phosphorus via precipitation and filtration.

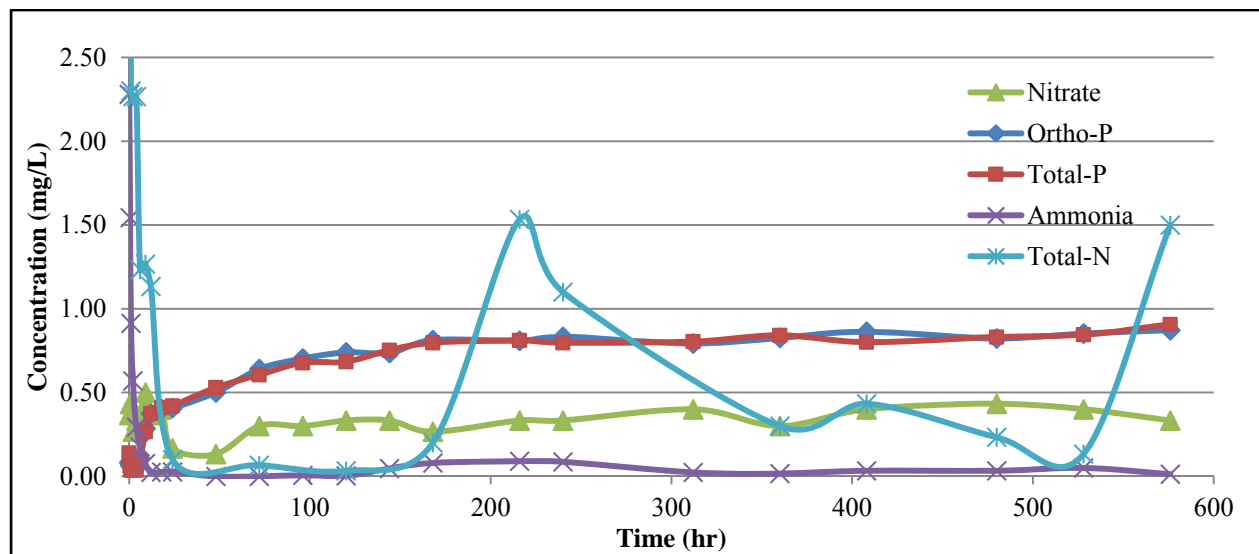

Figure 5-10 Effluent Concentrations Subjected to Spiked Pond Water with Influent PO_4 , NH_3 , and NO_3 Concentrations of $1 \text{ mg}\cdot\text{mL}^{-1}$ -P, $0.5 \text{ mg}\cdot\text{mL}^{-1}$ -N, and $0.5 \text{ mg}\cdot\text{mL}^{-1}$ -N, respectively, and Flow Rate of $0.167 \text{ L}\cdot\text{hr}^{-1}$ using BAM Nutrient mix 3-2. Averaged Concentrations of the three columns

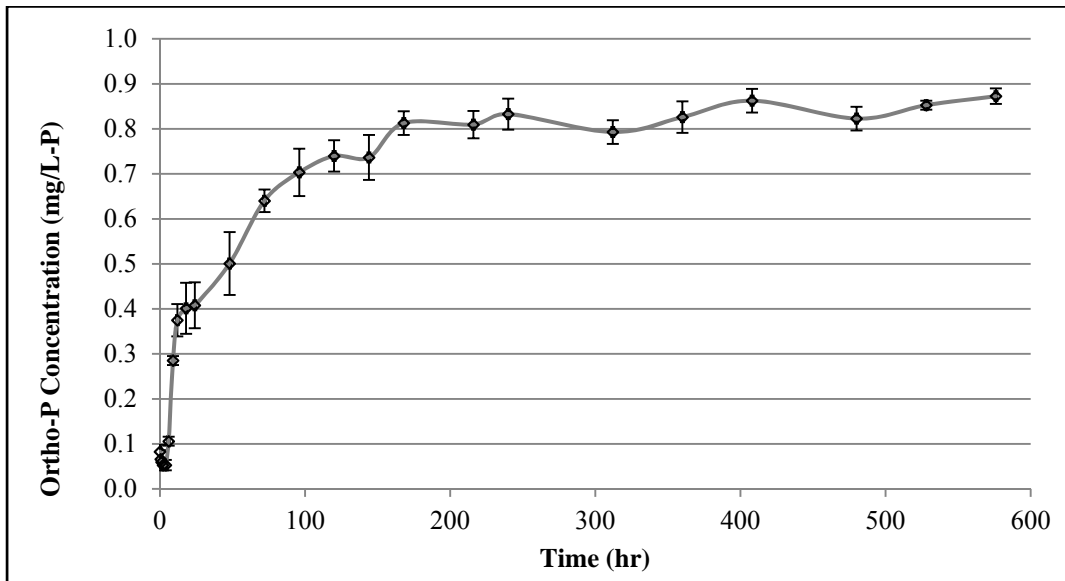

Figure 5-11 Orthophosphate Effluent Concentrations Subjected to Spiked Pond Water with Influent Total P Concentration of 1.04 mg·mL⁻¹ and Flow Rate of 0.167 L·hr⁻¹ using BAM Nutrient mix 3-2. Averaged Concentrations of the three columns

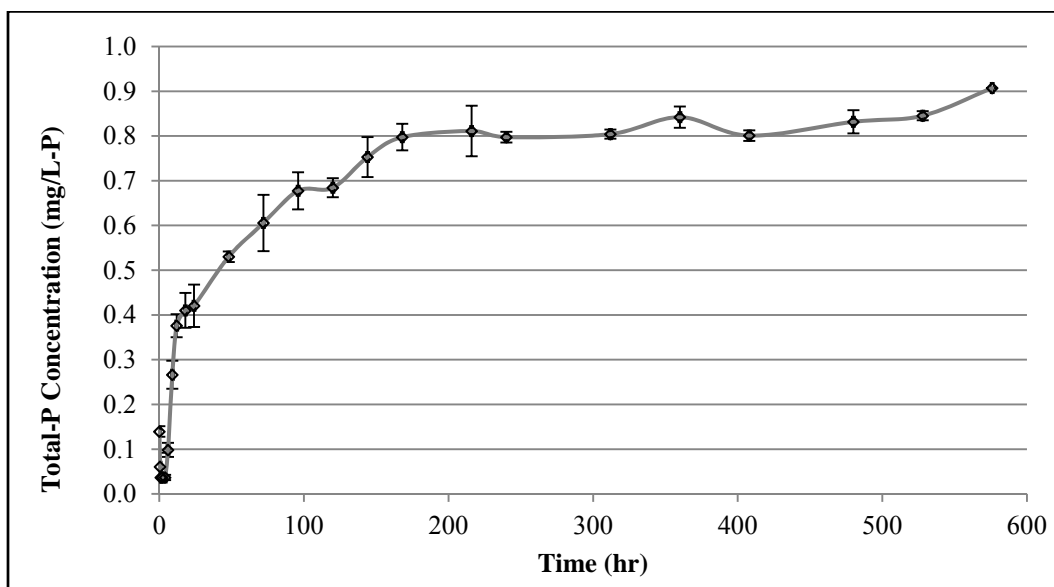

Figure 5-12 Total Phosphorus Effluent Concentrations Subjected to Spiked Pond Water with Influent PO₄ Concentration of 1 mg·mL⁻¹-P and Flow Rate of 0.167 L·hr⁻¹ using BAM Nutrient mix 3-2. Averaged Concentrations of the three columns

The initial elevation of ammonia from the system, shown in Figure 5-13, may be due to the conversion of organic or atmospheric nitrogen to ammonia. Wagner, (2012) showed that biological nitrogen fixation and the conversion of atmospheric nitrogen N₂ to ammonia may be completed by cyanobacteria, heterotrophic bacteria, and autotrophic bacteria. The column created an anoxic/anaerobic environment due to the residence time and plug flow assembly of the column. Consequently, there was the aeration of the inflow as it dripped into the column, supporting nitrification at the top of the column. As the flow approached the bottom of the column, it became more anoxic supporting denitrification, converting more NO₃ to N₂ gas. Figure 5-14 displays the high variability of the effluent nitrate, which differed greatly between each of the columns as it fluctuated with time due to the simultaneous nitrification and denitrification, adding and removing NO₃ at the same time.

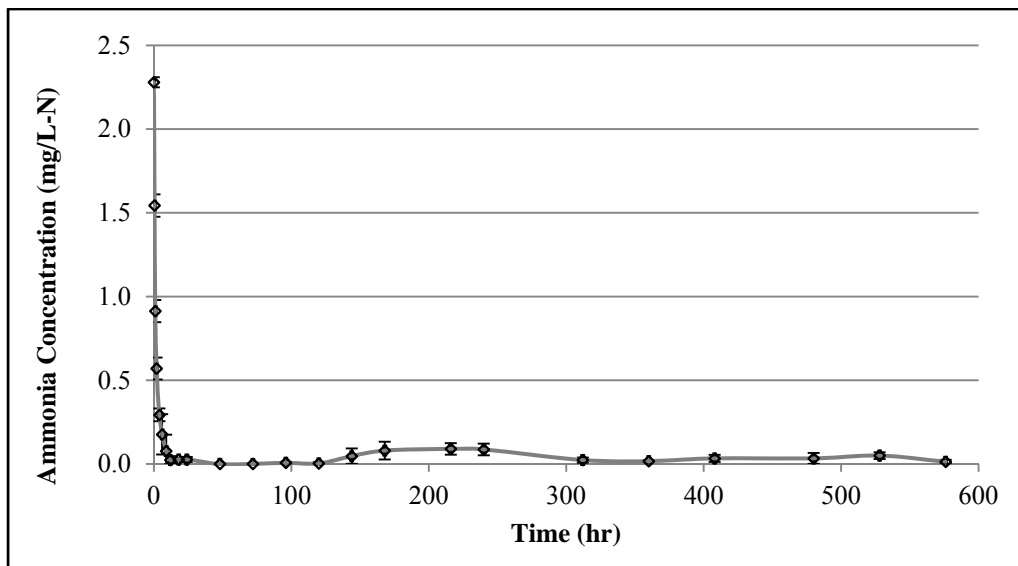

Figure 5-13 Ammonia Effluent Concentrations Subjected to Spiked Pond Water with Influent Ammonia Concentration of 0.5 mg·mL⁻¹ and Flow Rate of 0.167 L·hr⁻¹ using BAM Nutrient mix 3-2. Averaged Concentrations of the three columns

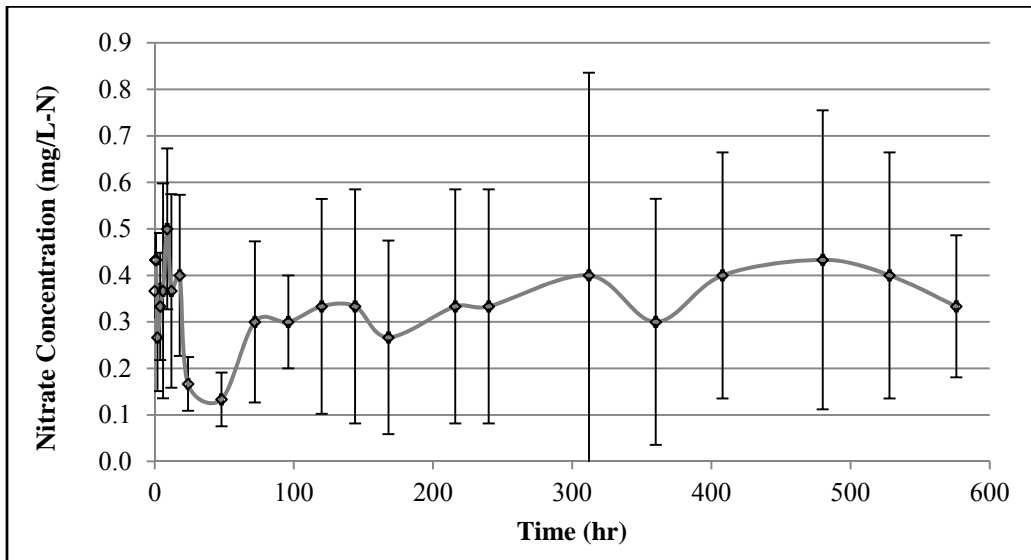

Figure 5-14 Nitrate Effluent Concentrations Subjected to Spiked Pond Water with Initial NO₃ Concentration of 0.5 mg·mL⁻¹-N and Flow Rate of 0.167 L·hr⁻¹ using BAM Nutrient mix 3-2. Averaged Concentrations of the three columns

The spike in total nitrogen around 200 minutes (Figure 5-15), where the total nitrogen increased from ~0.1 mg·L⁻¹ to 1.8 mg·L⁻¹ was most likely due to the new stormwater used for the experiment. This small peak also occurs at the same time in Figure 5-13 with concentrations of ammonia. Theoretically, the total nitrogen should be at least the sum of the ammonia and nitrate. The total nitrogen recorded is less than this value at some points due to the range of the TN test between 0.5 mg·L⁻¹ to 25.0 mg·L⁻¹ (Table 5-1).

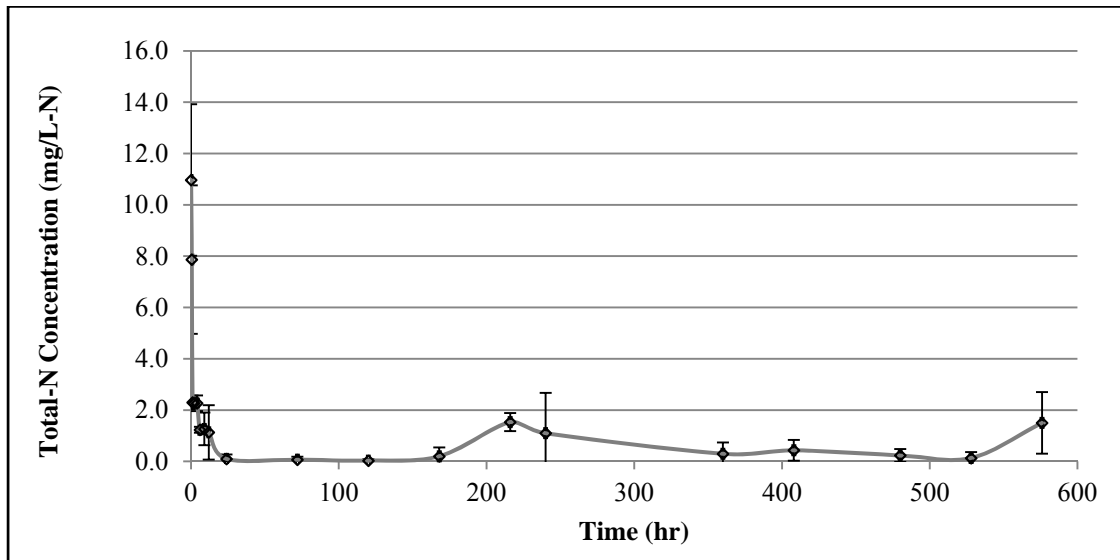

Figure 5-15 Total Nitrogen Effluent Concentrations Subjected to Spiked Pond Water with Flow Rate of 0.167 L·hr⁻¹ using BAM Nutrient mix 3-2. Concentrations are average values

5.6 FINAL REMARKS

The processes of physical straining and settling of the particulate fractions aided in the accomplishment of nitrogen removal. The removal of the dissolved fraction was primarily by biological activity. The basis for the use of a BAM filter was on the assumption that there would be 100% removal of all the particulate matter. However, from the results of chapters 3, 4 and 5, there was an average removal of 60% of the remaining dissolved nitrogen. The particulate fraction is normally around 40%. Thus, the computation for the overall removal of total nitrogen was $40\% + (100\% - 40\%)(0.60) = 76\%$ removal.

Although adsorption processes mostly determine the concentrations of inorganic-P in solution, influences of solid-state diffusion, precipitation-dissolution, and immobilization mineralization over longer periods also contribute to removal. Statistical analysis of the orthophosphate adsorption columns that compared the influence of pond water showed that the

elements of the pond significantly changed the rate of orthophosphate removal in the column. Using the Thomas Model to estimate the maximum adsorption equilibrium (q), results had a value of $0.0151 \text{ mg}\cdot\text{g}^{-1}$, about thirty times the value found under the same conditions using distilled water, which emphasizes the profound effects of the ions and elements (such as Fe, Mg, Ca, Al) in the pond water. The consistent reduction in ammonia and nitrate shows evidence of biological removal of nitrogen species. While effluent ammonia concentrations remained very low ($<0.10 \text{ mg}\cdot\text{L}^{-1}$), nitrate concentrations fluctuated greatly for each column because of simultaneous nitrification/denitrification by the aerobic/anoxic zones created within the column. SEM confirmed the creation of optimal environments for a biofilm growth on the expanded clay and tire crumb. Normally, the particulate fraction of total phosphorus is about 50%. With a removal of the dissolved fraction equal to about 80%, the overall removal of total phosphorus is $90 \% [(50\%) + (100\% - 50\%)(0.80)]$.

CHAPTER 6: DEMONSTRATIONS

6.1 INTRODUCTION

There are two classifications of filters for demonstration, on-line and off-line. Both are up-flow filters and use the same sorption media, called **BOLD & GOLD™**. The choice for the up-flow pattern of flow was to minimize maintenance due to clogging of filters, and subsequent reduction of the filtration rates. The on-line filter by-pass for flood control is to permit high flow above the media, while for the off-line filter the by-pass for flood control is to divert the high flow with a weir or diversion box. Provided at four locations was BAM Media. Water Quality measurements were used for two of them. Orange County and Watermark Engineering will monitor the other two. The sequence of presentation in this chapter is (1) off-line stormwater management method of filtration and (2) the on-line stormwater management filter.

6.2 OFF-LINE SORPTION MEDIA FILTRATION

The location of the filter was in the city of Dunnellon. The installation was full-scale to help remove phosphorus from discharging into Blue Cove Lake. The filter construction permitted sampling of the influent and effluent from the sorption media filter. The use of the results were to test the performance of an up-flow sorption filter treating about 80% of the stormwater that discharges to Blue Cove Lake. The goal was to acquire a better understanding of how up-flow sorption filters aid in the reduction of nutrients and metals in storm water runoff. Water quality tests included in the study were: Nitrate (NO_3), Soluble Reactive Phosphorus (SRP), Total Suspended Solids (TSS), Alkalinity, Ammonia (NH_3), Total Nitrogen (TN), Total Phosphorus (TP), Copper (Cu), Lead (Pb), and Zinc (Zn).

The up-flow sorption filter contained 432 ft³ (16 CY) of **BOLD & GOLD™** media as shown in the diagrams of Figure 6-1 through Figure 6-3. The influent pipe invert was set at an elevation eight inches higher than the invert of the effluent pipe. The diversion structure was set to divert the first inch of runoff water from the impervious roadway into the filter.

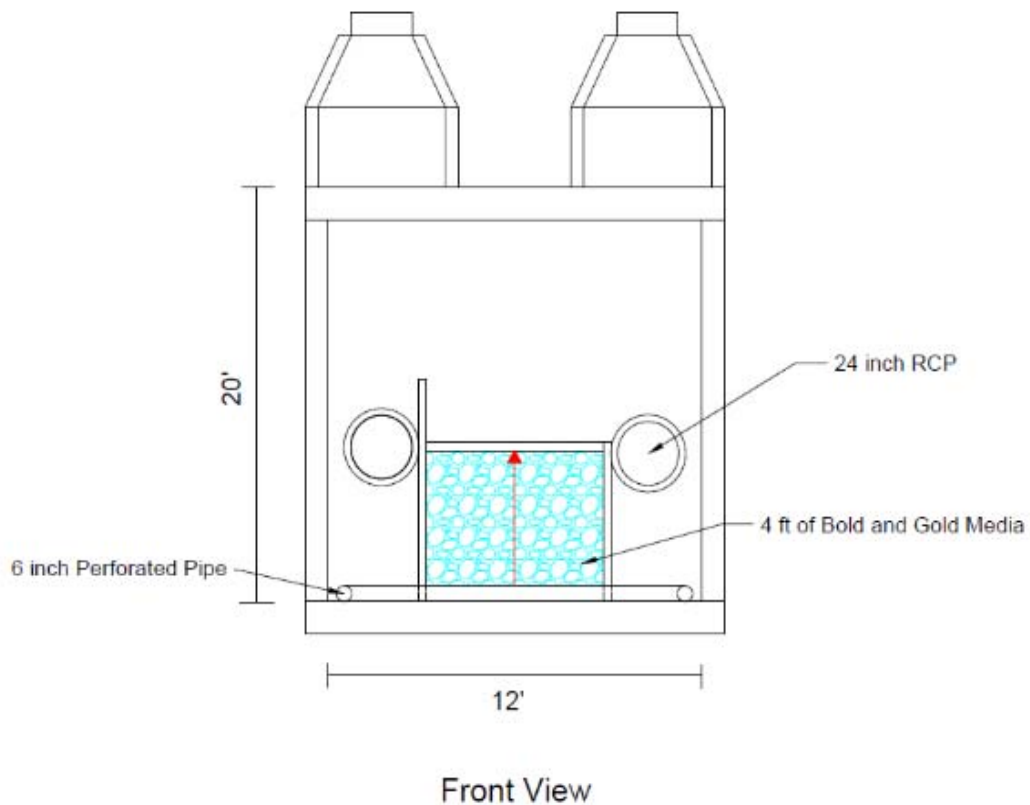

Figure 6-1 Diagram of the Up-flow Off-Line Sorption Filter (Front View)

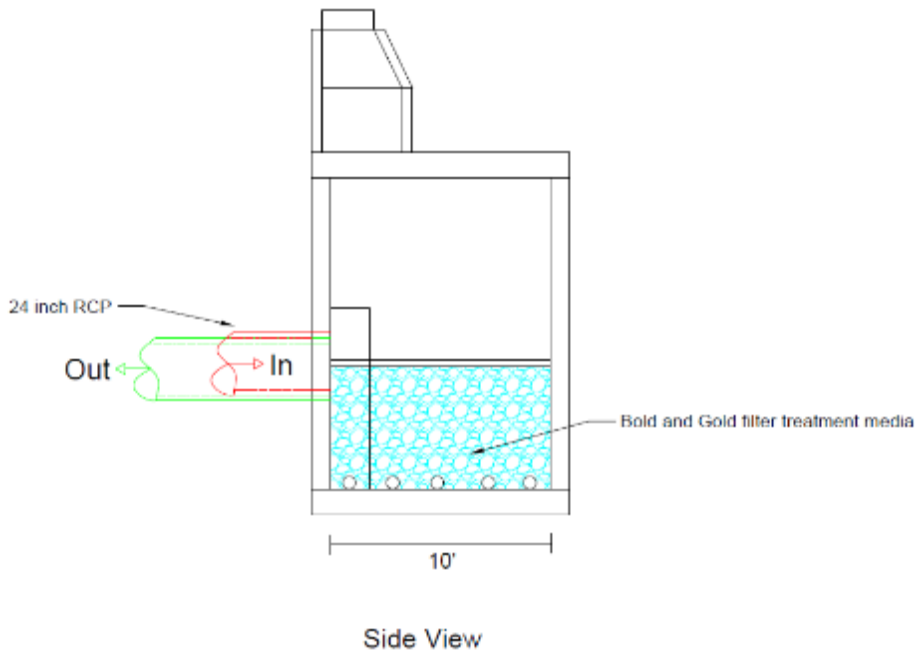

Figure 6-2 Diagram of the Up-flow Off-Line Sorption Filter (Side View)

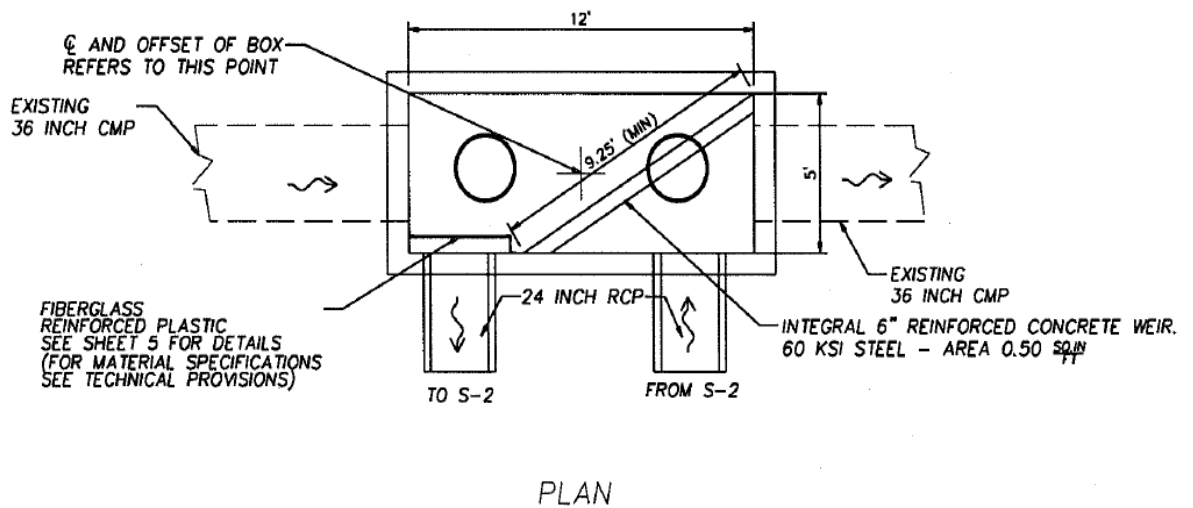

Figure 6-3 Diagram of the Diversion Structure for the Up-flow Off-Line Sorption Filter

The contributing catchment area is impervious and the flow from the area treated in the sorption filter. Figure 6-4 shows the sorption filter catchment and the total area. A wet detention pond treated the runoff from the other catchments. The impervious “untreated” area (highlighted green in Figure 6-4) contributes the majority of pollutant loading to the sorption up-flow filter. The total basin area was 87.38 acres, of which 31.6 acres was impervious. The “untreated” area going into the sorption up-flow filter was 1.50 acres, essentially all of which was effective impervious area.



Figure 6-4 Impervious Catchment area (green color) to off-line Sorption Filter

Figure 6-5 and Figure 6-6 show the photos of the construction prior to and after media placement, respectively.



Figure 6-5 Up-flow Off-Line Sorption Filter before Media Placement



Figure 6-6 Up-flow Off-Line Sorption Filter after Media Placement

6.3 ON-LINE SORPTION MEDIA FILTRATION

The location of the sorption filter was in the City of Kissimmee. The on-line sorption filter was an up-flow filter that is located within a nutrient-separation baffle box to treat stormwater runoff prior to discharge to Lake Toho. The filter is a standard feature within the nutrient removal system of Suntree Technologies, Inc. The sorption up-flow filter was located at the discharge side of the baffle box. There was 22 ft³ (0.8 CY) of media in the first filter configuration monitored as shown in Figure 6-7. The baffle box had a trash collector, sedimentation basins and the up-flow filter. During high flow, a floatable weir created a by-pass of the filter to prevent flooding upstream, Figure 6-8. Figure 6-9 is a picture taken during a low flow condition.

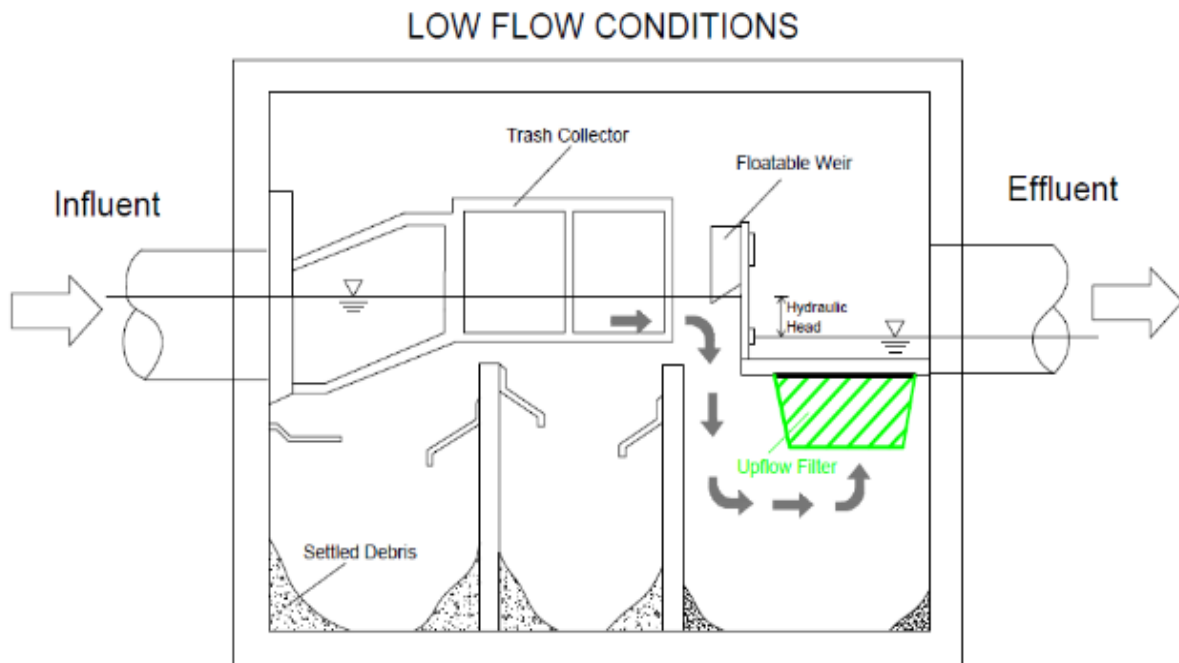

Figure 6-7 Diagram of Up-flow On-Line Sorption Filter during Low Flow

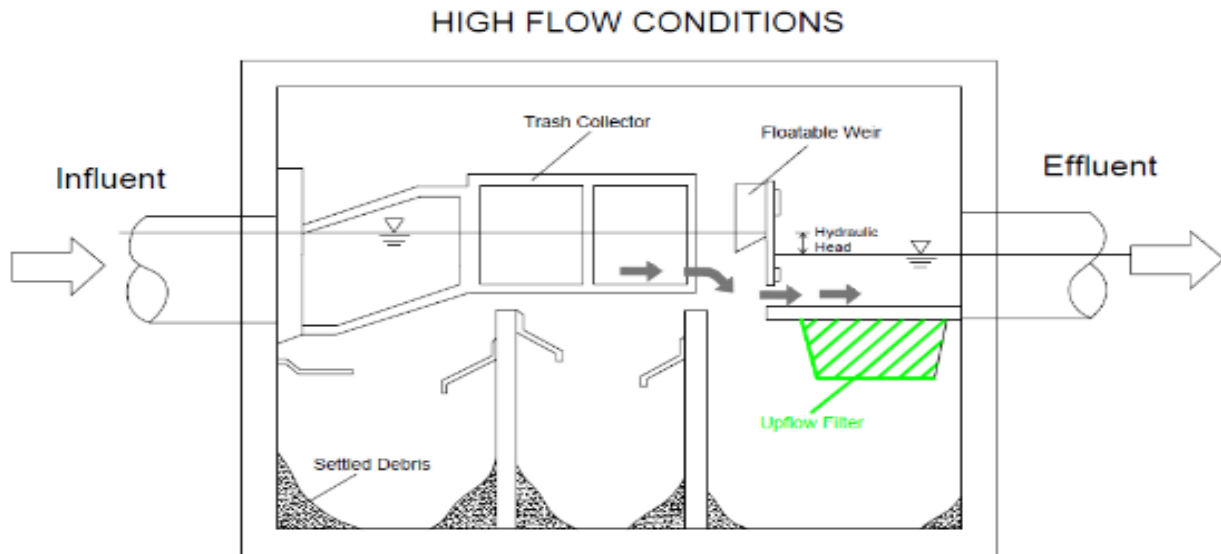

Figure 6-8 Diagram of Up-flow On-Line Sorption Filter during High Flow



Figure 6-9 Actual Operation of On-Line Sorption Filter during Low Flow

Figure 6-10 shows the catchment area for the on-line sorption filter. The total effective catchment area (rainfall equals runoff) was approximately 2.13 acres, and the effective area contributing to the up-flow on-line sorption media filter was about 0.47 acres. There were other filters and a wet land that served the remainder of the total catchment area. The nutrient-removal baffle box had an initial 0.8 CY and then 3.2 CY storage capacity. The use of the 0.8 CY capacity was to demonstrate the life expectancy. At 3.2 CY capacity, the expected life of the filter is 4 years.



Figure 6-10 Impervious Catchment Area to On-line Sorption Filter

6.4 WATER QUALITY EFFECTIVENESS

Used in testing the off-line sorption filter was one BAM volume, while two BAM volumes for the on-line filter design. The removal efficiency calculated for each water quality parameter was dependent on the collection of influent and effluent samples. The water quality tests performed for the study were: Nitrate (NO_3), Soluble Reactive Phosphorus (SRP), Total Suspended Solids (TSS), Alkalinity, Ammonia (NH_3), Total Nitrogen (TN), Total Phosphorus (TP), Copper (Cu), Lead (Pb), and Zinc (Zn).

6.4.1 Off-Line sorption filter test results

To evaluate the effectiveness of the off-line sorption filter in the reduction of nutrient concentration, there were six samples collected from the field tests. The removal of the

particulate fraction for nitrogen and phosphorus were most likely in the diversion-settling box and the filter. Table 6-1 and Table 6-2 present the average reduction in nutrient concentration and the complete data set for the filter operation, respectively. The basis for the computation of the average nutrient reduction of the off-line sorption filter was from the field data as shown in Table 6-2.

For total nitrogen removal, the overall system performance was based on 40% particulate nitrogen in pretreatment and 60% nitrogen removal by the filter, which equated to 76% calculated by the this formulation $40\% + (100\% - 40\%)(0.60) = 76\%$. The basis for the overall system performance for total phosphorus was on 50% particulate phosphorus removal which translate to 73% calculated by the this formulation $50\% + (100\% - 50\%)(0.46) = 73\%$. The filter effluent TSS was 17 mg/L, which is indicative that the filter removed most of the particulate fraction. The TN, TP and TSS concentrations from the street were about 2.10 mg/L, 0.36 mg/L and 100 mg/L, respectively.

Table 6-1 Off-Line Filter Effectiveness based on Concentration

Average Concentrations and % Removal	Total Nitrogen	Total Phosphorus	Total Suspended Solids
Concentration from the Street (mg/L)	2.10	0.360	100
Concentration to the Filter (mg/L)	1.27	0.180	35
Concentration from the Filter (mg/L)	0.502	0.098	17
Average Filter Removal (%)	60	46	51
Overall Average Removal (%)	76	73	83

Table 6-2 Off-Line Sorption Filter Water Quality Data

Date Collected	Sample Description	ALKALINITY (mg/L)	NH3 (µg/L)	NOx (µg/L)	ORG. N (µg/L)	TOTAL N (µg/L)	SRP (µg/L)	TOTAL P (µg/L)	TSS (mg/L)	TOTAL Cu (µg/L)	TOTAK Pb (µg/L)	TOTAK Zn (µg/L)
1/11/2014	influent	19.4	47	81	558	686	29	181	58.6	14	<2	126
	effluent	19.4	21	81	300	402	23	160	46.8	5	<2	71
1/16/2014	influent	40.6	3	86	735	824	24	59	11	9	<2	13
	effluent	38.0	3	81	310	394	23	55	9.6	9	<2	12
1/30/2014	influent	30.4	18	97	344	459	25	81	39.6	7	<2	23
	effluent	37.0	3	110	285	398	30	64	7	6	<2	19
2/6/2014	influent	57.0	444	340	2615	3399	187	405	24.4	9	<2	18
	effluent	46.8	45	147	451	643	72	103	12.6	5	<2	11
2/13/2014	influent	32.4	10	95	958	1063	19	186	16.6	5	<2	28
	effluent	30.8	13	64	578	655	14	132	19	5	<2	27
3/17/2014	influent	42.2	31	82	1076	1189	24	167	60.2	21	<2	34
	effluent	35.8	26	111	383	520	21	72	8.4	12	<2	28
average	influent	37.0	92	130	1048	1270	51	180	35	11	<2	40
	effluent	34.6	19	99	385	502	31	98	17	7	<2	28
	% Removal	6	80	24	63	60	41	46	51	35	NA	31

6.4.2 On-Line sorption filter test results

The initial testing of the media used simulated rainfall events on the watershed and not actual rainfall conditions. This was necessary because during actual rainfall conditions, the filter experienced backwater conditions from the Lake. However, the simulated conditions used street runoff water. The water quality into the filter from a settling chamber of a baffle box with up-flow filter (1/10th scale) was 1.87 mg/L for total nitrogen and 0.281 mg/L of total phosphorus. These concentrations did not include gross solids (rock, paper and leaves).

The influent water entered a settling chamber through a screen and then through an up-flow filter. For the settling volume and the filter, called the nutrient-removal baffle box,

computation for the average concentration reduction for total nitrogen and total phosphorus were on three sampling events, which gave the reduction efficiencies of 67% and 79%, respectively. The on-line sorption filter removal was 45% for total nitrogen and 58% for total phosphorus. There was no addition of gross solids, such as paper and leaves from the street, which could have increased the removal effectiveness. Table 6-3 presents the concentration reduction effectiveness for the simulated conditions.

Table 6-3 On-Line Effectiveness before Exhaustion using 0.8 CY of Media

	Total Nitrogen	Total Phosphorus	Total Suspended Solids
Average Influent Concentration (mg/L)	1.87	0.281	105
Average Filter Removal (%)	45	58	40
Average System Removal (%)	67	79	81

The event mean concentration (EMC) values from highway runoff in Florida for total nitrogen, total phosphorus, and total suspended solids are 1.64 mg/L, 0.22 mg/L and 100 mg/L, respectively. The EMC values for total nitrogen, total phosphorus and total suspended solids at the Kissimmee testing site were 1.87 mg/L, 0.281 mg/L and 105mg/L, respectively (Table 6-3), which were similar to the statewide average concentrations for these nutrients.

The inputs for the computation for the removal of dissolved phosphorus per gram of media before exhaustion were the filter input concentration of phosphorus (0.14 mg/L), the removal percentage, and the rainfall excess for the area. The estimated rainfall volume for the site before exhaustion was 29.20 inches or 2.44 feet. Thus, the calculation for phosphorus removed by the filter is

$$0.14 \text{ mg/L} \times 0.58 \times 0.47 \text{ acres} \times 2.44 \text{ feet} \times 1,235,000 \text{ L/acre-foot} = 115,000 \text{ mg}.$$

The weight of the media was 460,900 grams, expressed as

$$(0.8 \text{ CY} \times 27 \text{ CF/CY} \times 47 \text{ lb/CF} \times 454 \text{ gram/lb})$$

Thus, the removal of dissolved phosphorus by the filter per unit weight of filter is 0.25 mg. of phosphorus per gram of media (115,000/460,900).

Table 6-4 shows the water quality results without backwater influence from sampling locations before and after the filter with 0.8 CY of **BOLD & GOLD™** sorption media after the life expectancy time (exhaustion time). During sampling, significant amounts of water were bypassing the up-flow filter. The results showed that removal continued, however, at a low value, as additional sorption sites were available and the bypass continued.

Table 6-4 On-Line System Performance Data for 0.8 CY of Media after Exhaustion

Date Collected	Sample Description	ALKALINITY (mg/L)	NH3 (µg/L)	NOx (µg/L)	TOTAL N (µg/L)	SRP (µg/L)	TOTAL P (µg/L)	TSS (mg/L)	TOTAL Cu (µg/L)	TOTAK Pb (µg/L)	TOTAK Zn (µg/L)
9/25/2013	influent	134	409	500	1533	59	92	3.4	12	<2	31
	effluent	138	367	501	1501	61	89	2.1	20	<2	7
10/7/2013	influent	47.6	191	887	2474	191	302	30.2	12	<2	63
	effluent	46.0	190	637	2151	156	243	32.4	15	<2	77
10/23/2013	influent	93.8	71	645	1491	100	192	76.4	3	<2	20
	effluent	97.4	100	600	1420	90	101	2.2	3	<2	20
10/31/2013	influent	92.4	231	690	1573	44	212	8.4	6	<2	25
	effluent	90.6	221	673	1335	36	147	15.2	5	<2	20
11/2/2013	influent	89.6	370	967	2998	192	418	22	19	<2	77
	effluent	88.6	367	1022	2844	207	335	7.2	14	<2	63
11/16/2013	influent	47.0	173	352	1447	93	470	33.4	40	<2	60
	effluent	60.6	144	350	1392	82	421	32.8	31	<2	35
average	influent	84.1	241	674	1919	113	281	29	15	<2	46
	effluent	86.9	232	631	1774	105	223	15	15	<2	37
	% Removal	-3	4	6	8	7	21	47	4	<2	20

Table 6-5 presents the total nitrogen, total phosphorus, and total suspended solids percentage removal for the filter and the baffle box (including screening and settling) for after the media life expectancy period. The results indicated that nutrient removal continued but at a lower rate across the filter after exhaustion, but concentration removal for TSS remained high at 47%.

Table 6-5 On-Line Filter Effectiveness after exhaustion using 0.8 CY of Media

	Total Nitrogen	Total Phosphorus	Total Suspended Solids
Average Filter Removal (%)	8	21	47
Average System Removal (%)	45	60	82

The comparison of the filter removal effectiveness before (Table 6-3) and after (Table 6-5) the life expectancy period revealed that the suspended solids removal efficiency was approximately equal (81% and 82%), but the nutrient removal efficiency decreased. The bypass of the filter needed repair. Completed at the same time were repairs to the bypass and replacement of the media with a larger quantity (3.2 CY). The media may have been near exhaustion based on the results of the life expectancy testing reported from earlier chapters. The influent and effluent data verified exhaustion capacities. The data also indicated low levels of lead in the stormwater runoff and about 20% removal of Zinc.

The media in the on-line nutrient separating baffle box was replaced with a larger volume of **BOLD & GOLD™** that was 86 CF (3.2 CY), and measurements were taken of the filter performance. The initial volume of media was 0.8 CY for 29.2 inches of rainfall. The rainfall in the area is about 50 inches per year. To operate the filter for two years before exhaustion would require the treatment of 100 inches of rainfall, which was why the media volume had to be

increased by at least a factor of 3.4 (100/29.2). The quantity of filter media was at least 2.7 CY (3.4 x 0.8CY) and there was room available in the nutrient removal baffle box for 3.2 CY.

Water samples of the on-line sorption filter after repair and replacement revealed removal effectiveness similar to that reported before media exhaustion (Table 6-3). For the baffle box settling chambers and the up-flow filter, the average removal for TN and TP were about 70% for each parameter. While TN and TP removal by the filter alone were about 45% and 55% respectively. The average NO_x for the filter influent was 0.259 mg/L and the effluent was 0.127 mg/L for a removal of 51%. The effluent filter value for SRP averaged 0.040 mg/L compared to the expended filter average value of 0.105 mg/L indicating the new filter media had renewed phosphorus removal. Alkalinity decreased by about 3% through the filter for an effluent value of 60 mg/L. These sampling results are a partial validation of the removal results collected before media replacement. Analyzed was a water sample of the filter with algal growth. The results indicated an increase in the pre and post filter phosphorus levels. This leads to the conclusion that the top of the filter not be open to the atmosphere.

CHAPTER 7: CONCLUSIONS AND RECOMMENDATIONS

7.1 THE PROBLEM

In ultra-urban areas, there is limited space for the construction of stormwater facilities used as best management practices. Thus, the initial cost for the construction or retrofit of stormwater facilities located in ultra-urban areas can be expensive. The high cost outlay for stormwater facilities is also a factor of the need to 1) remove pollution from intensively used watersheds, 2) reduce peak flows, 3) maintain traffic, and 4) work around utility conflicts. In addition, ultra-urban environments are typically much more challenging in terms of meeting receiving water quality conditions. Consequently, FDOT potentially faces costly solutions to reduce pollution in ultra-urban environments.

7.2 CONCLUSIONS

The information in this report shows that sorption media reduces or removes nitrogen, phosphorus and other pollutants in stormwater. There are information to show the removal mechanism from the use of “spiked” distilled water in laboratory testing for life expectancy of the sorption media. These laboratory procedures calculate the duration for removal due to the sorption media and document the removal per unit weight of the media.

In addition, the use of stormwater in the laboratory study was to document other removal mechanisms generated by the ions in stormwater. Life expectancy increased with stormwater compared to the use of distilled water measures. The pond and runoff water contained calcium and iron, which are the most likely elements responsible for precipitation and sorption of the nutrients. Although the goal of this work does not include removal of metals in stormwater, the sorption media did removed some metals.

The primary removal mechanism for nitrogen was biological, provided the nitrogen compound was in the nitrate form and anoxic conditions were present. Direct measurements of the chemical species provided the data for removal documentation. Additional evidence was collected using scanning electron microscopy to identify the surface collection of microbial activity and to identify the surface area associated with the media.

There were two field sites used to document the construction, installation and performance of media filters in underground chambers. Input water to the filters were primarily from directly connected impervious surfaces. The filter located in Kissimmee Florida was an on-line filter operation and the filter at Dunnellon, Florida was an off-line operation. At the Kissimmee site, a media mix expected to last no more than one year based on the life expectancy was shown to last longer than a year, but at reduced efficiency.

Table 7-1 presents the removal effectiveness of the media and system during the media life expectancy during a well-maintained operation for the laboratory and field tests.

Table 7-1 Removal Percentages for Total Nitrogen and Total Phosphorus

Method of Testing	Total Nitrogen (%)	Total Phosphorus (%)
Laboratory Filter using Stormwater	76	90
Field Sites Filter Performance (range of removal for the two filters)	45-60	46-58
Field Sites System Performance (range of removal for the two system)	67 – 76	73 -75

7.3 DESIGN EXAMPLE WITH COST

To illustrate the filter design procedure and cost, following is an example problem that is consistent with standard practice in the State of Florida. The example problem calculations were for the volume of media needed given a replacement time consistent with the regulatory

frequency of certification. Used is a media replacement time of two years because that is the normal certification time required by the water management districts in the State. For certification, there must be either verification of performance or the media replacement. Generally, there is less expense to replace the media. Nevertheless, more media can extend the replacement time if desired. Underground space and construction budget must be available to implement the larger filtration system.

Removed were solid materials before the filter. Heavy solids settled and the floating materials collected on a screen. Thus, the filter operation was relatively clear of solids that cause filtration rate decreases.

The objective of this example was to show the calculations for the media volume necessary to remove phosphorus. The Event Mean Concentration of the runoff water for total phosphorus was 0.22 mg/L. The particulate fraction was 50%, or a concentration of 0.11 mg/L. Thus, the dissolved fraction was 0.11 mg/l. The receiving water or the groundwater receiving the discharge was limited to a concentration of 0.06 mg/L. The filter chamber was designed to settle particulate solids and to strain (screening possible) floating or low-density larger solids (paper and the like). The target non-particulate fraction removed was 0.05 mg/L (0.11-0.06).

Certification of the stormwater system is every two years. As part of the certification, the media must meet the intended removal effectiveness or the media replaced with new media. Accepted is the option to provide new media because the cost of sampling and data evaluation is greater than the cost of the media maintenance. In addition, for this particular site with space constraints, the construction cost of the filter structure was lower than building a structure that can contain a larger volume of sorption media.

The example watershed is a roadway area of 0.125 acres (27.6 feet × 197 feet roadway). The runoff is 4 foot of rainfall per year or a total of 8 feet in two years. Thus, the runoff is 1 acre-feet or 1,235,000 liters. The target dissolved phosphorus mass removal is the runoff volume times the concentration needed, or $1,235,000 \times 0.05$, which is 61,750 mg of dissolved phosphorus. From field data, the removal rate is 0.250 mg of dissolved phosphorus (OP) per gram of media. The wet media density is 47 pounds per cubic foot. Thus, the volume of media (**BOLD & GOLD™**) required is 0.43 CY ($61,750/0.25/454/47/27$) for two years of runoff.

As a comparison between the two demonstration projects, 16 CY of media are in the off-line filter at Dunnellon, Florida for an effective catchment area of 1.50 acres. What is required for a two-year replacement was 5.2 CY ($0.43\text{CY}/0.125$ effective catchment acres times 1.5 acres). Thus, the media should be functional for at least six years. For the on-line filter at Kissimmee, Florida, the filter in the nutrient-removal baffle box had a 3.2 CY capacity. The contributing area was 0.47 acres and for the same influent conditions, the volume of media needed for a two-year replacement was 1.6 CY [$(0.43\text{CY}/.125) \times 0.47$]. The volume used was 3.2 CY giving a four-year replacement time. These calculations were for the removal of dissolved phosphorus as the limiting factor.

From the construction cost data at the filter demonstration sites, the installed cost of filter media were \$5200 for 16 CY at Dunnellon and \$1040 for 3.2 CY at Kissimmee. The cost included transportation of the media to the site. For estimating purposes, the media cost installed was about \$325 per Cubic Yard. The labor for installation was twice the cost of the media. The housing cost for each filter unit varied with site conditions and pretreatment methods. Nevertheless, typical installation unit cost data for concrete filter containment normalized to a construction depth of 10 feet with no dewatering from the site data were about \$7200-\$9600 per

CY of media. The larger the volume of media, the lower the unit cost. Over a twenty year period of time and considering four media replacements, the media cost is about 15% of the total construction and operating cost.

7.4 RECOMMENDATIONS

1. In a laboratory environment, sorption media life expectancy for phosphorus removal should be determined using runoff water. Sorption and precipitation mechanisms are responsible for the removal of phosphorus. There is minimal biological removal. Laboratory methods under estimate removal rates.
2. Obtained from the field demonstrations was a removal rate of 0.25 mg dissolved phosphorus per gram of media.
3. Filtration and sedimentation of the particulate matter before the sorption filter is required to extend the life expectancy of the filter media and to increase the performance of the system.
4. Nitrogen removal is primarily by biological mechanisms. Promote a moist to wet condition during operation of the filter. The wet condition will promote anoxic conditions. Life expectancy for nitrate removal is dependent on the maintenance of anoxic conditions. The life expectancy for nitrogen removal is greater than the design life expectancy of the structure.
5. Both on-line and off-line underground chambers should include the placement of sorption filter material. The filters operate in an up-flow condition.

6. Avoid if possible backwater conditions. Negative removals were recorded when the filters were measured during backwater conditions. Not used to estimate performance effectiveness were measurements during backwater conditions.
7. Minimized should be debris build-up on the filters. Debris will cause more water to bypass the filter.
8. Expected removal of nitrogen and phosphorus is 70% during an average rainfall year. The two demonstration filters provide the data for estimating the removal.
9. Needed is maintenance for solids removal before the filters.

REFERENCES

- Austin Texas (2012). City of Austin Texas Environmental Criteria Manual. Section 1.6, Austin.
- Caltrans (2006). Highway 267 Filter Fabric Sand Trap Pilot Study, 2004–2005 Interim Report, California Department of Transportation, CTSW-RT-05-157.01.1.
- Chang, N., F. Hossain, M. Wanielista (2010). Filter Media for Nutrient Removal in Natural Systems and Built Environments: Previous Trends and Perspectives. *Environmental Engineering Sciences*, Volume 27, Number 9, pp 689-706.
- Crittenden, J., Trussell, R., Hand, D., Howe, K., & Tchobanoglous, G. (2012). *Water treatment, principles and design, third edition*. John Wiley & Sons, Inc., Hoboken, New Jersey
- Donlan, R.M. 2002. Biofilms: Microbial Life on Surfaces. *Emerg Infect Dis*. 8(9):881-890.
- EPA, Environmental Protection Agency (2008). Stormwater Technology Fact Sheet: Sand Filters. Washington D.C. EPA 832-F-99-007, September.
- Hardin, M., M. Wanielista, and M. Chopra (2012). A Mass Balance Model for Designing Green Roof Systems that Incorporate a Cistern for Re-Use. *Water*, 4, 1, doi: 10.3390/w40.
- Inglezakis, V.J. and S. G. Pouloupoulos, (2006) Basic Principles of Adsorption and Ion Exchange, in *Adsorption, Ion Exchange and Catalysis - Design of Operations and Environmental Applications*, Elsevier, Amsterdam, pp. 243-252.
- Jeffrey, D.W. 1998. General Concepts in Eutrophication. Pg. 1-9, Wilson, J.G. (Ed.). *Eutrophication in Irish Waters*. Royal Irish Academy, Dublin.
- Kim, H. H., E. A. Seagren, and A. P. Davis (2003). Engineered Bioretention for Removal of Nitrate from Stormwater Runoff, *Water Environment Research*, 75 (4): 355–367.
- Ma, J., K. Tracy, and J. Lenhart (2009). Phosphorus Removal in Urban Runoff Using Adsorptive Filtration Media, *Proceedings of Storm-Con 2009*, August 16–20, Anaheim, CA.
- MassHighway (2004). *Storm Water Handbook for Highways and Bridges*, Massachusetts Highway Department.
- Milesi, C., S. A. de Ridder, D. DeLeon, H. Wachter (2006). A Comparison of Two Media Filtration BMP Treatments for the Removal of PAHs and Phthalates from Roadway Runoff, *Proceedings of StormCon 2006*. July 24–27, Denver, CO.
- NCHRP (2012). Report 728, Guidelines for Evaluating and Selecting Modifications to Existing Roadway Drainage Infrastructure to Improve Water Quality in Ultra-Urban Areas, Transportation Research Board, Washington, D.C.

- O'Reilly, A., M. Wanielista, N. Chang, Z. Xuan, and W. Harris (2012). Nutrient removal using biosorption activated media: Preliminary biogeochemical assessment of an innovative stormwater infiltration basin. *Journal: Science of the Total Environment*. May.
- Palmstrom, N., Carlson, R., and Cooke, G. 1988. Potential links between eutrophication and formation of carcinogens in drinking water. *Lake Preserv Manage* 4:1-15.
- Pitt, R. and S. Clark (2010). Evaluation of Biofiltration Media for Engineered Natural Treatment Systems, Department of Civil, Construction and Environmental Engineering, University of Alabama.
- Ryan, P., M. Wanielista and N. Chang (2009). Nutrient Reduction in Stormwater Pond Discharge Using a Chamber Upflow Filter and Skimmer (CUFS), *Water, Air and Soil Pollution*, doi:10.1007/s11270-009-0174-x, Aug.
- Shoemaker, L., M. Lahlou, A. Doll, and P. Cazenias (2002). Stormwater Best Management Practices in an Ultra-Urban Setting: Selection and Monitoring, Federal Highway Administration, Washington, DC.
- Wanielista, M., T. Baldassari, P. Ryan, B. Rivera, T. Shah, and E. Stuart (2008), *Feasibility Study of Waste Tire Use in Pollution Control for Stormwater Management, Drainfields, and Water Conservation in Florida*, University of Central Florida Stormwater Management Academy, Department of Civil, Environmental, and Construction Engineering, Orlando, FL .
- Wanielista, M.P, N. Chang, M. Chopra, Z Xuan, K. Islam, and Z. Marimon. (2012). Floating Wetland Systems for Nutrient Removal in Stormwater Ponds. FDOT # BDK 78-985-01 Tallahassee, Fl.
- Woelkers, D., B. Pitt, and S. Clark (2006). Stormwater Treatment Filtration as a Stormwater Control, Proceedings of StormCon 2006. Denver, CO. July 24–27.
- WSDOT (2008a). Washington State Department of Transportation Highway Runoff Manual, M 31-16.01, Environmental and Engineering Programs Design Office.
- Zhao, B., Randall, A.A., Taylor, J.S. (2012) *Drinking Water Heterotrophic Plate Count: Monitoring Method Precision*, *Frensenius Environmental Bulletin*, **21**(5a), 1202-1211.

APPENDIX A

Calculations used for Nitrogen Balances

$$\text{Influent Organic Nitrogen} = \text{Influent TN} - \text{Influent NH}_3 - \text{Influent NO}_x$$

$$\text{Effluent Organic Nitrogen} = \text{Effluent TN} - \text{Effluent NH}_3 - \text{Effluent NO}_x$$

$$\text{Influent TN Available for nitrification} = \text{Influent NH}_3 + \text{Influent Organic N}$$

$$\text{Effluent available N not nitrified} = \text{Effluent NH}_3 + \text{Effluent Organic N}$$

Amount of Influent TN nitrified ($\mu\text{g/L}$ as N)

$$= (\text{Influent Available N for nitrification}) - (\text{Effluent Available for nitrification})$$

% of available TN that was nitrified

$$= \frac{(\text{Average amount of Influent TN nitrified})}{(\text{Average Influent TN Available for nitrification})}$$

% Removal of TN (i. e. % denitrification of influent TN)

$$= \frac{(\text{Average Influent TN} - \text{Average Effluent TN})}{\text{Average Influent TN}}$$

Assume amount of N removal due to growth of biomass is negligible and roughly the same for all media types.

Table A-1 Nitrogen Transformation and Removal: 2-Hour Storm Event; Average EBCT of 21.9 minutes (9/24/2013 – 11/18/2013)

Column Media #	Column Type	Average of Influent NO _x (mg/L as N)	Average of Effluent NO _x (mg/L as N)	Average of Influent NH ₃ (mg/L as N)	Average of Effluent NH ₃ (mg/L as N)	Average of Influent TN (mg/L as N)	Average of Effluent TN (mg/L as N)	Average Influent Organic Nitrogen (mg/L as N)	Average Effluent Organic Nitrogen (mg/L as N)	Influent TN available for Nitrification (mg/L as N)	Effluent TN available for Nitrification (mg/L as N)	Amount of Influent TN nitrified (mg/L as N)	% of available TN that was nitrified	% Removal of TN (i.e.% denitrification of influent TN)
1	A	0.239	0.370	0.723	0.355	1.665	1.206	0.703	0.482	1.426	0.836	0.590	41%	28%
1	B	0.239	0.392	0.740	0.385	1.694	1.269	0.715	0.491	1.455	0.877	0.578	40%	25%
1	C	0.218	0.219	0.736	0.641	4.444	3.984	3.491	3.124	4.226	3.765	0.461	11%	10%
2	A	0.239	0.468	0.723	0.447	1.665	1.398	0.703	0.483	1.426	0.930	0.496	35%	16%
2	B	0.239	0.437	0.740	0.456	1.665	1.453	0.686	0.560	1.426	1.016	0.410	29%	13%
2	C	0.218	0.254	0.736	0.696	4.444	4.304	3.491	3.355	4.226	4.051	0.176	4%	3%
3	A	0.239	0.516	0.723	0.355	1.665	1.351	0.703	0.480	1.426	0.835	0.590	41%	19%
3	B	0.239	0.417	0.740	0.433	1.665	1.320	0.686	0.470	1.426	0.903	0.523	37%	21%
3	C	0.218	0.171	0.736	0.776	4.444	4.209	3.491	3.262	4.226	4.038	0.188	4%	5%

Table A-2 Nitrogen Transformation and Removal: 24-Hour Storm Event; Average EBCT of 234.8 minutes (9/24/2013 – 11/18/2013)

Column Media #	Column Type	Average of Influent NO _x (mg/L as N)	Average of Effluent NO _x (mg/L as N)	Average of Influent NH ₃ (mg/L as N)	Average of Effluent NH ₃ (mg/L as N)	Average of Influent TN (mg/L as N)	Average of Effluent TN (mg/L as N)	Average Influent Organic Nitrogen (mg/L as N)	Average Effluent Organic Nitrogen (mg/L as N)	Influent TN available for Nitrification (mg/L as N)	Effluent TN available for Nitrification (mg/L as N)	Amount of Influent TN nitrified (mg/L as N)	% of available TN that was nitrified	% Removal of TN (i.e.% denitrification of influent TN)
1	A	0.306	0.059	0.731	0.291	1.503	0.843	0.466	0.492	1.197	0.783	0.414	35%	44%
1	B	0.306	0.104	0.722	0.184	1.503	0.718	0.475	0.431	1.197	0.615	0.582	49%	52%
1	C	0.249	0.013	0.781	0.740	4.113	4.129	3.082	3.377	3.863	4.116	-0.253	-7%	0%
2	A	0.312	0.651	0.722	0.155	1.503	1.264	0.470	0.458	1.192	0.613	0.579	49%	16%
2	B	0.312	0.467	0.722	0.264	1.503	1.117	0.470	0.386	1.192	0.650	0.542	45%	26%
2	C	0.249	0.133	0.781	0.821	4.113	4.108	3.082	3.154	3.863	3.975	-0.112	-3%	0%
3	A	0.312	0.276	0.722	0.229	1.503	1.129	0.470	0.624	1.192	0.853	0.339	28%	25%
3	B	0.312	0.177	0.722	0.250	1.503	0.878	0.470	0.451	1.192	0.701	0.491	41%	42%
3	C	0.249	0.028	0.781	0.824	4.113	3.685	3.082	2.833	3.863	3.657	0.206	5%	10%

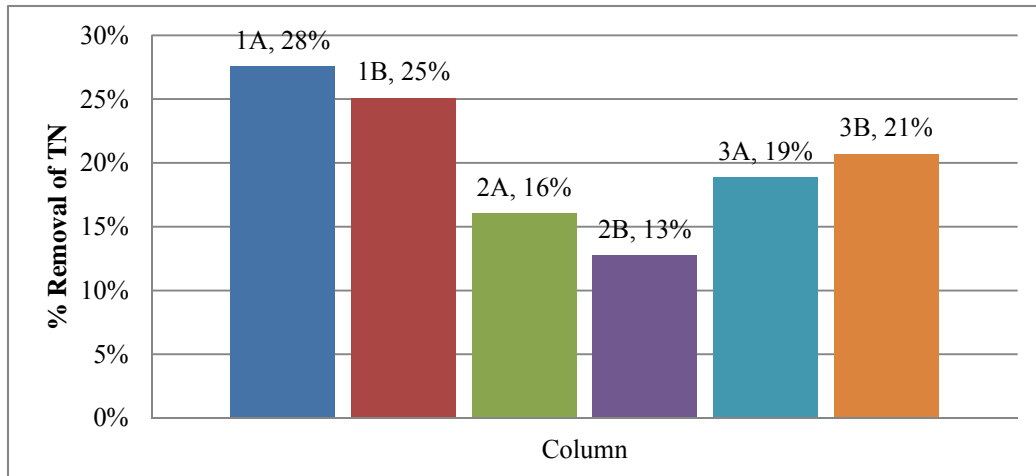

Figure A-1 % Average Removal of TN for each Column – 2 Hour Event; Average EBCT of 21.9 minutes (9/24/2013 – 11/18/2013)

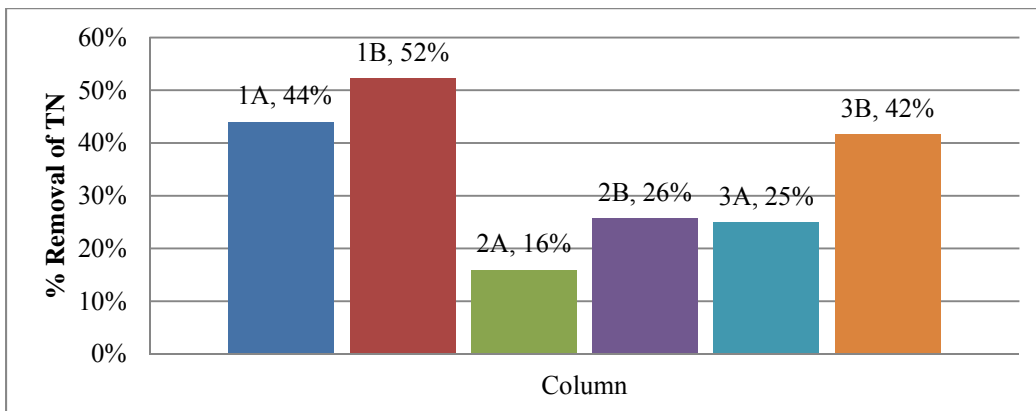

Figure A-2 % Average Removal of TN for each Column – 24 Hour Event; Average EBCT of 234.8 minutes (9/24/2013 – 11/18/2013)

Table A-3 Nitrogen Transformation and Removal for each Column: Comparison of 2-Hour & 24-Hour Events (9/24/2013 -11/18/2013)

Column	2-Hour: % of available TN that was nitrified [avg. EBCT = 21.9 min]	24-Hour: % of available TN that was nitrified [avg. EBCT = 234.8 min]	2-Hour: % Removal of TN (Denitrification) [avg. EBCT = 21.9 min]	24-Hour: % Removal of TN (Denitrification) [avg. EBCT = 234.8 min]
1A	41%	35%	28%	44%
1B	40%	49%	25%	52%
2A	35%	49%	16%	16%
2B	29%	45%	13%	26%
3A	41%	28%	19%	25%
3B	37%	41%	21%	42%

Table A-4 Soluble Reactive Phosphorus Removal for each Column (4/1/2013 - 11/18/2013)

Approximate Flow Duration (hours)	Column Media #	Column Type	Average Influent SRP (mg/L as P)	Average Effluent SRP (mg/L as P)	Δ SRP (mg/L as P)	SRP % Removal
2	1	A	0.188	0.079	-0.109	58%
2	1	B	0.191	0.084	-0.107	56%
2	2	A	0.188	0.119	-0.069	37%
2	2	B	0.188	0.128	-0.059	32%
2	3	A	0.188	0.108	-0.079	42%
2	3	B	0.188	0.109	-0.078	42%
24	1	A	0.177	0.063	-0.114	65%
24	1	B	0.177	0.058	-0.119	67%
24	2	A	0.177	0.113	-0.064	36%
24	2	B	0.177	0.111	-0.066	37%
24	3	A	0.177	0.123	-0.054	31%
24	3	B	0.177	0.149	-0.028	16%

TableA-5 Total Phosphorus Removal for each Column (4/1/2013 -11/18/2013)

Approximate Flow Duration (hours)	Column Media #	Column Type	Average Influent TP (mg/L as P)	Average Effluent TP (mg/L as P)	Δ TP (mg/L as P)	TP % Removal
2	1	A	0.233	0.108	-0.125	54%
2	1	B	0.237	0.120	-0.117	49%
2	2	A	0.233	0.154	-0.079	34%
2	2	B	0.233	0.200	-0.033	14%
2	3	A	0.233	0.143	-0.090	39%
2	3	B	0.233	0.126	-0.107	46%
24	1	A	0.229	0.149	-0.080	35%
24	1	B	0.229	0.157	-0.073	32%
24	2	A	0.229	0.152	-0.077	34%
24	2	B	0.229	0.172	-0.058	25%
24	3	A	0.229	0.201	-0.029	12%
24	3	B	0.229	0.193	-0.036	16%



© 2014