

Roundabouts and Access Management

FDOT Project BDK77 977-22

Final Report

March 2014

Prepared for:

Florida Department of Transportation
605 Suwannee Street, MS 19
Tallahassee, FL 32399

Project Manager:

Gina Bonyani
Systems Planning Office



Prepared by:

Principal Investigator
Dr. Ruth L. Steiner
Department of Urban & Regional Planning
University of Florida
431 Architecture Building
Gainesville, FL 32611

Dr. Scott Washburn, Dr. Lily Elefteriadou
Engineering School of Sustainable Infrastructure and the Environment
University of Florida
365 Weil Hall
Gainesville, FL 32611

Dr. Albert Gan
Department of Civil and Environmental Engineering
Florida International University
10555 West Flagler Street, EC 3603
Miami, FL 33174

Disclaimer

The opinions, findings, and conclusions expressed in this publication are those of the authors and not necessarily those of the State of Florida Department of Transportation.

Metric Conversion Table

SYMBOL	WHEN YOU KNOW	MULTIPLY BY	TO FIND	SYMBOL
LENGTH				
in.	inches	25.4	millimeters	mm
ft.	feet	0.305	meters	m
yd.	yards	0.914	meters	m
mi	miles	1.61	kilometers	km

Technical Report Documentation Page

1. <u>Report No.</u>	2. Government Accession No.	3. Recipient's Catalog No.	
4. Title and Subtitle Roundabouts and Access Management		5. Report Date March 2014	
		6. Performing Organization Code	
7. Author(s) Ruth L. Steiner, Scott Washburn, Lily Elefteriadou, Albert Gan, Priyanka Alluri, Dimitra Michalaka, Ruoying Xu, Shanty Rachmat, Benjamin Lytle, Amy Cavaretta		8. Performing Organization Report No.	
9. Performing Organization Name and Address Department of Urban and Regional Planning University of Florida P.O. Box 115706 Gainesville, FL 32611-5706		10. Work Unit No. (TRAIS)	
		11. Contract or Grant No. BDK77-977-22	
12. Sponsoring Agency Name and Address Florida Department of Transportation 605 Suwannee Street, MS 30 Tallahassee, FL 32399		13. Type of Report and Period Covered Final Report September 2012 – March 2014	
		14. Sponsoring Agency Code	
15. Supplementary Notes Gina Bonyani, FDOT Project Manager			
16. Abstract <p>Transportation engineers and planners are becoming more interested in using roundabouts to address access management and safety concerns in the transportation system. While roundabouts are being used increasingly in a variety of contexts, existing research does not provide detailed guidance on how to evaluate the use of roundabouts as a form of access management. This Florida Department of Transportation (FDOT) research project has three primary components: a review and assessment of national and state guidance related to roundabouts and access management, a safety analysis of all 283 roundabouts in Florida, and an operational analysis of selected roundabouts. Literature related to safety, access management, and multimodal transportation (especially for bicyclists and pedestrians, and roadway capacity associated with the use of roundabouts) is reviewed, and gaps in knowledge regarding the use of roundabouts are identified, particularly as they apply to safety, access, and capacity. One of the findings of the literature review is that little research has been completed on access management near roundabouts. A review of national and state guidance identifies major studies including NCHRP 672 and guidance in Kansas, Wisconsin and Virginia that recommend intersection and driveway spacing similar to that recommended for un-signalized intersections. The safety and operational analysis identifies four areas of concern: corner clearance, including stopping site distance (SSD) and intersection sight distance (ISD); the need for guidance on the functional area near roundabouts including driveway and intersection spacing, and the use of medians; access to major activity centers; and safety of vulnerable road users, especially bicyclists and pedestrians. The operational analysis confirms previous research that shows that roundabouts are similar to un-signalized intersections, but the differences may influence the operations and safety within the functional area of the roundabout. An assessment of the primary FDOT utilized software tools focuses on the current suitability of these software tools to assist practitioners in assessing the suitability of incorporating roundabouts into existing and proposed roadway configurations. Recommendations are made for additional national research on guidance on driveway and intersection spacing, medians, and SSD and ISD in the different contexts in which roundabouts are installed. Changes to the FDOT's <i>Access Management Tools, Median Handbook</i> and <i>Driveway Information Guide</i> are also recommended along with the development of Florida-specific parameters for capacity and safety analysis. Modifications to roundabout design guidelines and handbooks for access management will lead to safer, more effective, and ultimately, better performing roundabouts for all users of Florida's transportation system and throughout the United States.</p>			
17. Key Words: Roundabout, access management, safety, capacity, operational analysis		18. Distribution Statement No restrictions.	
19. Security Classif. (of this report) Unclassified.	20. Security Classif. (of this page) Unclassified.	21. No. of Pages 177	22. Price

Form DOT F 1700.7 (8-72) Reproduction of completed page authorized

Roundabouts and Access Management

Page iv

Acknowledgements

The project team would like to thank Gina Bonyani and Gary Sokolow, of the Florida Department of Transportation (FDOT) Systems Planning Office, for their assistance in understanding the scope of the project and for their feedback. The research team wishes to acknowledge the efforts of national experts on roundabouts, including Andrea Bill, Phil Demosthenes, Patrick Flemming, Hillary Isebrands, Mark Johnson, Howard McCullough, Lee Rodegerdts, Eugene Russell, Jeff Shaw, Ken Sides, Michael Wallwork, and Brian Walsh, for their willingness to participate in this research in a variety of ways, including discussing design, safety, policy, and other topics related to access management near roundabouts, providing time in meetings of the ITE Roundabouts and the Transportation Research Board (TRB) Roundabouts Committee, and to reviewing the drafts of this final report.

Executive Summary

*Summary of Final Report, BDK77 977-22
March 2014*

Background

Over the last twenty years, engineers and planners have become increasingly interested in the use of roundabouts because they offer several advantages over other traffic controls; they may cost less to install, have greater safety potential by reducing the number of conflict points, can accommodate a series of U-turns and left-turn lanes and reduce delay in a corridor, and, may have lower operations and maintenance costs. Florida has recently begun to encourage the use of roundabouts on the state highway system and is systematically updating its guidance documents (e.g., Plans Preparation Manual, Intersection Design Manual, and Manual on Uniform Traffic Studies) but needs guidance on what to include in the *Median Handbook*, and *Driveway Information Guide* and other access management documents.

Objectives

The purpose of this study is to understand previous research and state and national guidance on roundabouts and access management, and to conduct empirical research on the safety and operation of roundabouts in Florida. Advice on implementing roundabouts and access management into state guidance documents will be provided. The research objectives were achieved by completing the following tasks:

1. Literature and background review of national and state guidance;
2. Safety analysis of all 283 roundabouts in Florida;
3. Operational analysis of thirteen selected roundabout sites in Florida; and
4. Software tools review for roundabout simulation and evaluation.

Findings and Conclusions

The review of national guidance on roundabout and access management shows that only five federal access management reports refer to roundabouts: *AASHTO Green Book*, NCHRP Report 672 – *Roundabouts: An Informational Guide, Second Edition*, NCHRP Report 572 – *Roundabouts in the United States*, NCHRP Report 674 – *Crossing Solutions at Roundabouts and Channelized Turn Lanes for Pedestrians with Vision Disabilities*, and NCHRP Synthesis 264 – *Crossing Solutions at Roundabouts and Channelized Turn Lanes for Pedestrians with Vision Disabilities*. NCHRP Report 672, which is the most relevant to this report, refers to the access management in the context of roundabouts and reinforces the idea that many of the access management principles that apply to conventional intersections can be applied to roundabouts.

State guidance on roundabouts and access management provides varying levels of specificity, with most states adopting national guidance from NCHRP Report 672 – *Roundabouts, An Informational Guide*; a few states provide state-specific parameters and guidance. While several states adopt local parameters for roundabouts, only three states – Wisconsin, Virginia, and Kansas – address the use of access management within the broader context of the design of roundabouts.

The safety and operational analyses of existing roundabouts in Florida identify three areas of concern about access management near roundabouts: (1) conflicts within the functional area of roundabouts; (2) safety of vulnerable road users, including pedestrians and bicyclists; and (3) roundabouts that provide direct access to activity centers. Of a total of 2,941 crashes that occurred from 2007 – 2011 within 500 ft. of the 283 roundabouts in the state, 1,882 crashes were directly related to a roundabout; this is an average of 6.65 crashes per roundabout with an average of 8.10 and 5.4 crashes each around commercial and residential land uses, respectively. Consistent with the previous findings, the safety and operational analysis of roundabouts showed a relative low rate of crashes, but some areas of concern. The operational analysis identified situations in which a left-turning vehicle or pedestrians could cause delays in vehicles moving through the roundabout. The safety analysis showed that crashes involving vehicles turning left at median openings were relatively rare. While the safety analysis showed that the downstream driveway corner clearance has a greater safety impact than the upstream driveway corner clearance, the operational analysis did not identify such conflicts. High pedestrian and bicycle volumes can affect the capacity and the

effective operation of roundabouts. Crashes involving pedestrians and bicycles were about 4% of all crashes, but no general conclusions can be drawn due to the small sample size and the lack of good exposure data. The safety and operational analysis had somewhat conflicting results for roundabouts at activity centers. Roundabouts with three or four legs, with direct access to activity centers, are equally as safe as roundabouts without direct access to roundabouts. However, in activity centers with high volumes of pedestrians and bicyclists, erroneous driver behavior, such as stopping in the middle of the roundabout to pick-up or drop-off pedestrians, causes delays for other drivers. The operational analysis did not identify other concerns found in the literature, including spillback into the roundabout from a downstream bottleneck, which would result in completely locking the roundabout.

A major conclusion of this research is that, while much research has been conducted about roundabouts and about access management, little research has been conducted on roundabouts in combination with access management and roundabouts as a form of access management. Roundabouts are a form of access management because they can accommodate left turns and allow the removal of directional left-turn lanes; yet they function as intersections. How queues form and traffic operates in the functional area around roundabouts is less well understood than for other types of intersections. The differences in roundabout safety and operational characteristics from other types of access management and other intersections means that the site distances, stopping distances, functional area characteristics, and intersection and driveway spacing may be different from other types of intersections.

Recommendations

As Florida starts incorporating roundabouts into its practices, consistent guidance on the use of roundabouts that address the diverse situations under which roundabouts are implemented should be provided. Of the 283 roundabouts in Florida, only four are located on the state highway system; the rest are located in a variety of regional contexts – urban, suburban and rural – with diverse designs and access considerations, and at different distances from the nearest community centers, highways, interstates, and state highways. Essential to this guidance is consideration of the differences between roundabouts and other types of intersections, and to types of access management, such as driveways, and medians. It is essential to understand the effects of roundabouts on traffic conditions, safety and traffic network operations. The findings of both the safety and operational analysis reinforce the need to accommodate bicyclists and pedestrians around roundabouts. While this research did not identify significant problems with trucks and other large vehicles, the need to accommodate them is likely to become an issue as roundabouts are more widely used along state roadways and other high-capacity roadways where roundabout design needs to account for adequate lateral clearance and larger radius. Florida has already adopted NCHRP 672, *Roundabouts, An Informational Guide* but the state should conduct and support additional research on the use of roundabouts. The FDOT should support national research that specifically focuses on the functional area of roundabouts on major arterials. The state should consider the use of locally-developed parameters for various aspects of design and operational analysis of roundabouts. Recently, the City of Sarasota, in consultation with the FDOT, has proposed a series of roundabouts on US 41. The FDOT has a unique opportunity to complete a before-and-after study on the operational and safety characteristics of corridors of roundabouts instead of conventional intersections in this corridor.

Benefits

Roundabouts offer several advantages over other traffic controls: they may cost less to install, have greater safety potential by reducing the number of conflict points, can accommodate a series of U-turns and left-turn lanes and reduce delay in the corridor, and can have and may have lower operations and maintenance costs. The guidance resulting from this research can certify that roundabouts are implemented in a manner that ensures improved safety and capacity while maintaining access to nearby businesses.

This research project was conducted by Ruth L. Steiner, of the University of Florida. For more information, contact Gina Bonyani, Project Manager, at 850-414-4707, Gina.Bonyani@dot.state.fl.us.

Table of Contents

Disclaimer	ii
Metric Conversion Table	iii
Technical Report Documentation Page	iv
Acknowledgements	v
Executive Summary.....	vi
Background.....	vi
List of Figures.....	xii
List of Tables	xiv
List of Abbreviations	xv
Chapter One: Introduction.....	1
1.1 Background	1
1.2 Research Questions.....	2
1.3 Objective of Research.....	3
1.4 Scope of Work and Supporting Tasks.....	3
1.5 Organization of the Report	6
Chapter Two: Literature Review.....	7
2.1 Overview	7
2.2 Roundabouts.....	7
2.2.1 Modern Roundabouts	7
2.2.2 Geometric Design.....	8
2.2.3 Contexts of Roundabouts.....	11
2.2.4 Comparing Roundabouts to Other Types of Intersection Traffic Controls	13
2.3 Access Management.....	13
2.3.1 Access Management Elements	14
2.3.2 Spacing Standards and Roadway Classifications.....	14
2.3.3 Access Management Mechanisms and Intersection Controls.....	16
2.3.4 Impact of Roundabouts on Access Management	18
2.4 Operational Effects of Roundabouts.....	19
2.4.1 Effect of Traffic Flow and Driver Behavior.....	19
2.4.2 Effect of Geometry	20
2.4.3 Operational Analysis of Roundabout.....	20
2.4.4 Roundabout Capacity under Different Conditions.....	21
2.4.5 Summary of Roundabout Operation Literature Review.....	22
2.5 Roundabouts and Safety	23
2.5.1 Overall Safety Effects of the Roundabouts	24

2.5.2 Aspects of Safety Performance of Roundabouts	25
2.5.3 Safety for Different Roundabout Users and Modes	29
2.5.4 Methods in Roundabout Safety Analysis.....	35
2.5.5 Roundabouts and Safety: Conclusion	39
2.6 Evaluation of Gaps in Roundabout Literature	40
2.6.1 Literature Gaps in Access Management	40
2.6.2 Literature Gaps in Roundabout Operations and Capacity	40
2.6.3 Literature Gaps in Roundabout Safety.....	41
Chapter Three: Methodology.....	43
3.1 Access Management and Roundabout Guides' Selection.	43
3.2 Site Identification.....	45
3.3 Safety Analysis	46
3.3.1 Categorize Roundabout Locations.....	46
3.3.2 Extract Crash Data.....	47
3.3.3 Correct Crash Locations and Review Police Reports	47
3.4 Operational Analysis	50
3.4.1 Data Collection Site Selection	50
3.4.2 Data Collection	53
3.4.3 Data Analysis	54
Chapter Four: Review of National and State Practices	56
4.1 National and State Guidebooks for Roundabouts and Access Management.....	56
4.1.1 National Guidance for Access Management.....	56
4.1.2 States' Guidance for Access Management.....	61
4.1.3 National and State Guidebooks for Roundabouts	62
4.1.4 State Guidance for Roundabouts.....	65
4.2 State of Florida Guidance.....	68
4.2.1 Access Management Guidance in Florida.	68
4.2.2 Roundabouts Guidance for Florida.....	75
4.3 National Guidance on Access Management in the Context of Roundabouts.....	76
4.4 States' Guidance on Access Management in the Context of Roundabouts.....	77
4.5 Roundabout Location Guidelines	80
4.6 Geometry Design Guidelines	81
Chapter Five: Safety Analysis	88
5.1 Overall Crash Statistics.....	88
5.1.1 Area Type	88
5.1.2 Crash Type	88
5.1.3 Crash Severity	90

5.1.4 Number of Vehicles Involved	91
5.2 Impact of Driveway Corner Clearances on Roundabout Safety.....	91
5.3 Safety Impact of Median Openings in the Vicinity of Roundabouts.....	94
5.4 Safety at Roundabouts That Provide Direct Access to Activity Centers.....	100
5.5 Safety of Vulnerable Road Users	104
5.5.1 Pedestrians.....	104
5.5.2 Bicyclists.....	105
5.6 Summary of Findings	106
Chapter Six: Operational Analysis	109
6.1 Overview of Data Collection Sites	109
6.2 Analysis of Access Management Issues Affecting Operations.....	109
6.2.1 Conflicts at Access Point within Roundabout’s Functional Area.....	109
6.2.2 Conflicts with Pedestrians.....	110
6.2.3 Violation of Traffic Rules	111
6.2.4 Summary of Operational Analysis	112
6.3 Assessment of Software	112
6.3.1 HCS.....	113
6.3.2 Synchro	114
6.3.3 SIDRA	115
6.3.4 RODEL and ARCADY	115
6.3.5 VISSIM	115
6.3.6 CORRIDOR SIMULATION (CORSIM)	116
6.3.7 Summary	118
Chapter Seven: Discussion.....	119
7.1 Overview	119
7.2 Roundabouts and Access Management in Florida.....	120
7.2.1 Summary of Safety Analysis	120
7.2.2 Summary of Operational Analysis	122
7.3 Roundabouts and Access Management Guidance.....	124
7.3.1 Summary of National and State Guidance on Roundabouts	124
7.3.2 Summary of National and State Guidance on Access Management	125
7.3.3 Summary of National and State Guidance on Roundabout and Access Management.....	126
7.3.4 Summary of Florida’s Guidance on Roundabouts and Access Management.....	127
7.4 Synthesis of Findings of the Research.....	128
7.5 Recommendations.....	131
7.5.1 Recommendations for Florida’s Guidance on Roundabouts and Access Management	131
7.5.2 Recommendations for Additional Research	134

Chapter Eight: Conclusions	136
8.1 Conclusions of the Review of National and State Guidance	136
8.2 Conclusions About Safety Analysis of Roundabouts in Florida	136
8.3 Conclusions About Operational Analysis of Roundabouts in Florida	137
8.4 Final Remarks	137
8.5 Additional Research Needs.....	138
References Cited	140
Appendix A: Roundabouts Features and Dimensions.....	149
Key Features of a Modern Roundabout	149
Dimensions	149
Appendix B: State Policies	151
Appendix C: Access Management Techniques in State Guidelines	161
Appendix D: Site Selection.....	165

List of Figures

Figure 1. Geometric Design Features of a Typical Modern Roundabout (FDOT, 2007)	8
Figure 2. Geometric Design Features of a Typical Modern Roundabout: Single-lane (b) and Multiple-Lane Roundabouts (c)	9
Figure 3. Intersection Sight Distance (FHWA, 2006, p. 18)	11
Figure 4. Stopping Sight Distance (FHWA, 2006, p. 19).....	11
Figure 5. Access and Road Classification.....	15
Figure 6. Relationship between Access Management, Roadway Design, Traffic Operations and Land Use (Rose et al., 2005).....	16
Figure 7. Crash Types on a Typical Roundabout (Arndt and Troutbeck, 1998, p. 28-3).....	24
Figure 8. Vehicle Conflicts and Vehicle-Pedestrian Conflicts at Signalized Intersections and Single-Lane Roundabouts (Rodegerdts et al., 2010, Exhibit 5-2, p. 5-7).....	26
Figure 9. Different Marking Systems (Bie et al., 2005).....	28
Figure 10. (1) Mixed traffic; (2) adjacent bike lanes; (3) separated bike lanes with priority for bicyclists; and (4) separated bike lanes without priority for bicyclists (Daniels and Wets, 2005, p. 6-8)	31
Figure 11. Crash Frequencies in Roundabouts (Isebrands, 2009b)	36
Figure 12. Data Required for Chi-Square Analysis (Flannery and Datta, 1996, p. 6)	36
Figure 13. Examples of Roundabouts Located in Each Land Use Type	47
Figure 14. Crashes Displayed by Crash Type at a Roundabout	48
Figure 15. Crashes Displayed by Crash Severity at a Roundabout.....	48
Figure 16. An Example of a Crash That Was Not Directly Related to the Roundabout.....	49
Figure 17. Data Collection using Web-based Tool.....	50
Figure 18. Roundabout sites in Florida Selected for Operational Analysis	52
Figure 19. Camera Location of Video Recording for Independent Drive and South Laura Street in Jacksonville	54
Figure 20. Roadway Function Classification in Florida (FDOT, 2010, p. 24)	69
Figure 21. Driveway Design and Spacing (FDOT, 2008, p. 9)	69
Figure 22. Effective Radius and Curb Radius (FDOT, 2008)	70
Figure 23. Ramp Spacing (FDOT, 2008, p. 78)	71
Figure 24. Roundabout at an Interchange (FHWA, 2006, p. 8).....	72
Figure 25. Corner Clearance (FDOT, 2008, p. 73)	72
Figure 26. Corner Clearance for Downstream (FDOT, 2008, p.76).....	73
Figure 27. Sight Distance and Driver Eye Setback Driveway Information Guide (FDOT, 2008, p. 62)	74
Figure 28. Joint and Cross Access (FDOT, 2008, p. 86)	74
Figure 29. Typical Dimensions for Left-turn Access near Roundabouts (Rodegerdts et al., 2010, p.6-98)...	77
Figure 30. Measured Distance from Splitter Island to First Access Point (KsDOT, 2013, p. 4-26)	79
Figure 31. Minimum Spacing Standards for Commercial Entrances, Intersections, and Crossovers (VDOT, 2007, p. F-23)	80
Figure 32. The Effect of Design Elements (WisDOT, 2011, p.38).....	81
Figure 33. <i>Example Solution Design with Circulating-Exiting Path Conflict (Caltrans, 2007, p.62)</i>	83
Figure 34. Solution Options for Circulating-Exiting Path Conflict: (i) Modify Lane Configuration, and (ii) Realign Approaches (Caltrans, 2007, p.63-64)	83
Figure 35. Angle of Visibility: (i) the Angle is Too Severe (ii) Realigned Ramp Terminal Approach to Have Better Angle of Visibility (Caltrans, 2007, p. 65).....	84
Figure 36. Statistics by Area Type.....	89
Figure 37. Total and Nighttime Crash Statistics by Crash Type	90
Figure 38. Statistics by Crash Severity	90
Figure 39. Upstream and Downstream Driveway Corner Clearances	92

Figure 40. Roundabout on SR A1A, Nassau County, Florida with Reduced Sight Distance at Downstream Corner Clearance	94
Figure 41. Case 1 - Vehicles Turning onto a Driveway Downstream of the Roundabout.....	95
Figure 42. Case 2 - Vehicles Turning Left from a Driveway Upstream of a Roundabout.....	96
Figure 43. An Example of a Crash at a Median Opening Involving a Vehicle Turning Left From the Main Street Onto a Driveway	97
Figure 44. An Example of a Crash at a Median Opening Involving a Vehicle Turning Left From a Driveway Onto the Main Street	97
Figure 45. A Non-incapacitating Injury Involving a Vehicle Turning Left from Driveway and a Bicyclist....	97
Figure 46. Examples of Crashes Involving Heavy Vehicles at Roundabouts.....	98
Figure 47. Closing Median Openings Prevent Vehicles From Turning Left From the Driveway	99
Figure 48. Closing Median Openings Prevent Vehicles From Turning Left From the Main Street	99
Figure 49. A Corridor with Two Roundabouts on Segovia Street, Miami Dade County, Florida	100
Figure 50. An Activity Center with Access Through a Major Driveway	101
Figure 51. An Activity Center with Direct Access from a Roundabout.....	101
Figure 52. Examples of Six-legged Roundabouts that Experienced High Crashes.....	103
Figure 53. Fatal Crash Involving a Pedestrian (Crash ID: 772427040)	104
Figure 54. Corridor on SW 2 nd Avenue, Gainesville, Alachua County, Florida.....	106
Figure 55. Conflict of Left-turn Vehicle at Roundabout (SW 2nd Avenue and SW 6 th in Alachua County)..	110
Figure 56. Roundabout Observation on Spill Back of Entering Traffic into an Adjacent AWSC Intersection (NE 10th Ct. and SW 152 nd Ave., Miami).....	110
Figure 57. Roundabout Observation with Pedestrian Conflict (Independent Dr. and S. Laura St., Duval County)	111
Figure 58. Roundabout Observation with Driver Violation of Traffic Rules (Independent Dr. and S. Laura St., Duval County)	111
Figure 59. Roundabout Observation with Spill Back from Driveway into Circulating Lanes (Causeway Blvd. and Mandalay Ave., Pinellas County)	112
Figure 60. Interface of HCS 2010.....	113
Figure 61. User Interface of Synchro (Trueblood, 2013)	114
Figure 62. Example of Roundabout Simulation in VISSIM (FHWA, 2011)	116
Figure 63. Example of Modeling Roundabout in CORSIM (Elias, 2009).....	117
Figure 64. Conditional Turn Movement in CORSIM (Elias, 2009)	117
Figure 65. Conflict and Spillback associated with Left-turn Access to Driveway.....	122
Figure 66. Solution 1- Dedicated Left-turn Lane for Access to Driveway.....	123
Figure 67. Solution 2 – Right-lane Access.....	123
Figure D.1. Camera Location of Roundabout at Causeway Blvd and Mandalay Ave.....	165
Figure D.2. Camera Location of Roundabout at SW 2 nd Ave and SW 6 th St.	166
Figure D.3. Camera Location of Roundabout at MLK Blvd. and N. Central Ave.	167
Figure D.4. Camera Location of Roundabout at Eagle’s Reserve Blvd and Dyer Blvd.....	168
Figure D.5. Camera Location of Roundabout at Independent Dr. and S. Laura St.....	169
Figure D.6. Camera Location of Roundabout at CR-707 and Ave A	170
Figure D.7. Camera Location of Roundabout at CR-210 and Mickler Rd.....	171
Figure D.8. Camera Location of Roundabout at NE 10th Ct. and SW 152 nd Ave.	172
Figure D.9. Camera Location of Roundabout at Greenway Dr. and Segovia St. & Coral Way	173
Figure D.10. Camera Location of Roundabout at Biltmore Way and Sagovia St.	174
Figure D.11. Camera Location of Roundabout at Holmberg Rd. and Parkside Dr.	175
Figure D.12. Camera Location of Roundabout at Ponce De Leon Blvd. and Ruiz Ave.....	176
Figure D.13. Camera Location of Roundabout at Margate Blvd. and NW 58 th St.	177

List of Tables

Table 1. Selection of Analysis Tool (Rodegerdts et al., 2010).....	23
Table 2. Detailed Countermeasures for Design Elements (Lord et al., 2007, p. 429)	32
Table 3. Advantages and Disadvantages of Roundabout for Pedestrians (Furtado, 2004).....	33
Table 4. Main Documents on Access Management – Related State DOT Guidebooks	44
Table 5. The Sources of Roundabout States’ Design Guidebooks	45
Table 6. Summary of Roundabouts in Florida by Design and Context.....	46
Table 7. Criteria for Selecting Roundabouts for Operational Analysis	51
Table 8. Summary of Roundabout Selection Process.....	52
Table 9. Summary of Features and Survey Time of Selected Roundabouts of Thirteen Roundabouts and Data Collection Times for Operational Analysis.....	53
Table 10. Main Documents of the Access Management - Related State DOTs Guidebooks.....	62
Table 11. Roundabout States’ Design Guidebooks Reviewed in this Document	65
Table 12. Access Management Standards from Rule 14-97 (FDOT, 2006, p. 15).....	73
Table 13. Roundabout Design Speed	82
Table 14. Recommended Headway Values (WisDOT, 2011, p31)	82
Table 15. Wisconsin DOT Minimum Visibility Distance	84
Table 16. Typical Inscribed Circle Diameter Ranges (Caltrans, 2007, p. 67)	84
Table 17. Common Ranges of Inscribed Circle Diameters (Caltrans, 2007, p.68)	85
Table 18. The Guidelines Comparison for Design Vehicles on Multi-lane Roundabouts (Caltrans, 2007).....	86
Table 19. Statistics by Area Type	88
Table 20. Statistics by Crash Type	89
Table 21. Statistics by Crash Severity and Area Type	91
Table 22. Statistics of Single-vehicle and Multi-vehicle Crashes by Area Type	91
Table 23. Statistics of Single-vehicle and Multi-vehicle Crashes by Crash Severity.....	92
Table 24. Driveway-related Crashes That Occurred within Upstream and Downstream Driveway Corner Clearances	93
Table 25. Statistics of Roundabouts with Three and Four Legs	102
Table 26. Statistics of Roundabouts with Five and Six Legs	102
Table 27. Pedestrian Crash Statistics by Median Type.....	105
Table 28. Bicycle Crash Statistics by Location and Crash Severity	106
Table 29. Input and Output for Roundabout Components in HCS 2010.....	114
Table 30. Recommended Selection of Analysis Tool for Different Applications Regarding Roundabouts and Access Management	118
Table A.1. Key Features of a Modern Roundabout.....	149
Table A.2. Dimensions of Roundabouts	149
Table B.3. State Websites and Guidance on Roundabouts and Access Management	151
Table B.4. Roundabout Guidelines in Driveway or Highway Manuals	153
Table B.5. Specific Manuals on Roundabout Guidance.....	154
Table B.6. State Guidance on Access Management Manuals.....	156
Table B.7. Other Documents Related to Access Management.....	160
Table C.8. Spacing Requirements	161
Table C.9. Access Management Elements on the States (Gluck and Lorenz, 2010, page 48)	162
Table C.10. Access Management Techniques applied by the State DOTs (Gluck and Lorenz, 2010, pages 49- 50).....	163

List of Abbreviations

AADT	Average Annual Daily Traffic
AASHTO	American Association of State Highway and Transportation Officials
ADA	Americans with Disabilities Act
ANOVA	Analysis of Variance
ARCADY	Assessment of Roundabout Capacity and Delay
AWSC	All-Way Stop Controlled
AzDOT	Arizona Department of Transportation
CMF	Crash Modification Factors
CORSIM	Corridor Simulation
CS	Conflicting Speed
DCEE	Department of Civil and Environmental Engineering
DOT	Department of Transportation (general; applies to any state or states collectively)
ESSIE	Engineering School of Sustainable Infrastructure and the Environment
FDOT	Florida Department of Transportation
FHWA	Federal Highway Administration
FIU	Florida International University
ft.	Feet
FTA	Federal Transit Administration
FWSC	Four-way Stop Controlled
GIS	Geographic Information Systems
HCM	Highway Capacity Manual
HCS	Highway Capacity Software
HSM	Highway Safety Manual
ICD	Inscribed Circle Diameter
INDOT	Indiana Department of Transportation
IowaDOT	Iowa Department of Transportation
ISD	Intersection sight distance
ITE	Institute of Transportation Engineers
km/h	Kilometers per hour
KSU	Kansas State University
KYTC	Kentucky Transportation Cabinet
LOS	Level of Service
LOSPLAN	Level of Service Planning
MEV	Million Entering Vehicles
MDOT	Michigan Department of Transportation
mi.	Miles
MNDOT	Minnesota Department of Transportation
mph	Miles per hour
MPO	Metropolitan Planning Organization
NCHRP	National Cooperative Highway Research Program
NHDOT	New Hampshire Department of Transportation
ODOT	Oregon Department of Transportation
PDO	Property Damage Only

PennDOT	Pennsylvania Department of Transportation
PHB	Pedestrian Hybrid Beacon
RCI	Roadway Characteristics Inventory
RTM	Regression-to-the-mean
SPF	Safety performance functions
SSD	Stopping sight distance
TRB	Transportation Research Board
TWSC	Two-way stop controlled
UF	University of Florida
URP	Department of Urban and Regional Planning
VISSIM	Verkehr in Städten – Simulations Model
WisDOT	Wisconsin Department of Transportation
WSDOT	Washington State Department of Transportation

Chapter One: Introduction

1.1 Background

Transportation engineers and planners are increasingly interested in using roundabouts to address access and safety concerns in the transportation system. Several states have strongly encouraged the use of roundabouts because they may cost less to install than signalized intersections, may have a greater safety potential by reducing the number of conflict points, and depending upon the context, lower operations and maintenance costs (TRB, 2010a). Roundabouts have “seen unprecedented growth across the United States, from just a handful a decade ago to more than 2,000 and counting” (Schroeder et al., 2011, p. 1). A recent Federal Highway Administration (FHWA) and Federal Transit Administration (FTA) (Rue et al., 2010) publication describes the benefits of roundabouts from a livability perspective:

...they manage queuing and congestion at intersections by allowing simultaneous operation of some crossing movements; they break potential vehicle-pedestrian conflicts into two discrete points by use of their splitter islands; and they slow traffic moving through the intersection, while increasing capacity. They offer greater safety, eliminating the potential for head-on collisions and focusing drivers’ attention on the roadway ahead, and toward other cars and pedestrians. Although they require construction adjustments to existing geometry of the intersecting roadways, they offer safety and operational benefits that make them work more effectively than traffic signals by most measures (Rue et al., 2010, p. 6).

Although roundabouts are in use in many contexts, existing research does not provide detailed guidance on how to evaluate the use of roundabouts as a form of access management or as part of a larger roadway network. *Roundabouts, An Informational Guide* suggests the advantage of roundabouts as a method to “facilitate U-turns that can substitute for more difficult mid-block left turns, especially where there is no left turn lane” (Rodegerdts et al., 2010, p. 29). Examples from other communities suggest that a corridor using multiple roundabouts can accommodate a series of U-turns and left-turn lanes and reduce delay in the corridor. However, *Roundabouts, An Informational Guide* also suggests that roundabouts “may reduce the number of available gaps for mid-block signalized intersections and driveways” (Rodegerdts et al., 2010, p. 29) and thus reduce the capacity of these access points. At the very least, the traffic along a corridor changes with the introduction of roundabouts; the traffic may be more uniformly distributed with a larger number of smaller gaps rather than fewer large ones. The challenges of using roundabouts along a corridor are described in greater detail in the following:

It is common practice to coordinate traffic signals on arterial roads to minimize stops and travel time delay for through traffic on the major road. A roundabout with only yield control cannot be actively managed to provide priority to major street movements in the same way. As a result, the coordinated platoons of traffic that improve the efficiency of traffic signals can be disrupted by roundabouts, thus reducing the efficiency of downstream intersections. Roundabouts cannot be managed using a centralized traffic management system to facilitate special events, divert traffic flows, and so on unless signals at the roundabout or in the vicinity are used for such a purpose (TRB, 2010a, pp. 2-6).

However, the benefits of a roundabout may vary for different users. Prior research shows generally consistent results about crash rates but the perceptions of the safety of roundabouts varies among diverse users. Research is also needed on the operational aspects of roundabouts, especially as it relates to all roadway users; priority for one type of user may cause delays for other types of users. Access management may also require establishing priority for specific movements at or near roundabouts that affect their operations.

Access management benefits have been documented in various National Cooperative Highway Research Program (NCHRP) reports, both for signalized and unsignalized intersections; roundabouts are generally included as unsignalized intersections. The most recent document on access management—NCHRP Report 548 (TRB, 2003)—states that access management has a number of positive benefits: improved safety, reduction in delay, increased environmental friendliness in terms of fuel consumption and emissions, improved access to properties, integration of land use and transportation, and the provision of appropriate function for highways with reduced cut-through traffic. To maximize roundabout benefits and to achieve the main purposes of roundabout utilization, the integration of roundabout and access management is required.

In summary, roundabouts have the potential to increase safety and reduce delay by controlling access and more readily accommodating U-turn and left-turn movements. However, less is known about how to evaluate roundabouts compared to other forms of access management and intersection control with respect to travel delay, safety, and other community performance measures. Additionally, many of the micro-scale details about access management near roundabouts and along corridors, like the location of driveways and the placement and use of medians, are not well defined in the literature and are potentially more flexible with roundabouts than conventional intersection designs.

NCHRP Project 03-65: Applying Roundabouts in the United States, has resulted in two major national research reports on the use of roundabouts: NCHRP Report 572: *Roundabouts in the United States* (Rodegerdts et al., 2007) and NCHRP Web-Only Document 94: *Appendices to NCHRP Report 572; Roundabouts in the United States* (Rodegerdts et al., 2006). These reports include an inventory of roundabouts in the United States at the time of the publication of the document, and a database of geometric, operational, and safety information. The results of this research have been incorporated into the *Highway Safety Manual* (HSM) (TRB, 2010b) and the *Highway Capacity Manual* (HCM) (TRB, 2000). *Roundabouts, An Informational Guide* was first published in 2000 and updated through NCHRP Project 03-65A to produce *NCHRP Report 672: Roundabouts: An Informational Guide, Second Edition* (Rodegerdts et al., 2010). This guide contains sections on roundabout considerations, planning, operational analysis, safety, geometric design, application of traffic control devices, illumination, landscaping, and construction and maintenance. The FHWA Office of Safety has a *Roundabout Outreach and Education Toolbox* (FHWA, 2013) that includes a variety of case studies from different states, focusing on how to educate the public to properly and safely use roundabouts.

1.2 Research Questions

The main question addressed in this research is, “What aspects of access management should be incorporated into the state guidance documents in the state of Florida on roundabouts with respect to their usage near driveways and along corridors?”

This main question is addressed through an exploration of the following sub-questions:

- (a) What can we learn from existing literature about the operation, capacity, safety and access associated with roundabouts?
- (b) How have roundabouts been incorporated into national and state guidance documents on access management?
- (c) What guidance on operation, capacity, safety, access management, and design has been incorporated into national and state guidance documents on roundabouts?
- (d) How have access management, safety, operations, and capacity considerations associated with roundabouts been incorporated into current practices?
- (e) Has access management influenced the safety of existing roundabouts in Florida?
- (f) Has the Florida state government included roundabouts in their access management and driveway management documents? How does access management figure into roundabout design documents?

-
- (g) What do State of Florida documents recommend in regard to access management in the vicinity of roundabouts?

1.3 Objective of Research

The main objective of this research is to provide guidance for transportation professionals in Florida on how access management around roundabouts should be managed. This objective is achieved through several tasks starting from a review of previous literature and other state guidelines on roundabouts to see how these guidelines are applied throughout the United States. The goal is to understand how access management, capacity, and safety are addressed; to evaluate the gaps in knowledge regarding the use of roundabouts; to analyze crashes near roundabouts; to conduct an operational analysis of a sample of roundabouts; and to assess the primary software tools for analyses of roundabouts. The research recommends changes to guidance documents in Florida, including the access management resources, *Median Handbook*, and *Driveway Information Guide*.

Researchers at the University of Florida (UF) and Florida International University (FIU) accomplished these goals through a series of tasks including: review of literature and other research on roundabouts, evaluation of the gaps in knowledge regarding the use of roundabouts, safety analysis of crashes within 500 feet of all 283 roundabouts in the state of Florida, operational analysis of a sample of thirteen roundabouts, review of software used to evaluate roundabouts, and development of recommendations for additional research and specific guidance on the deployment of roundabouts. The Department of Civil and Environment Engineering at FIU completed the safety analysis, made recommendations regarding their analysis and reviewed the entire document. Faculty from the UF's Transportation Institute in the Engineering School of Sustainable Infrastructure and Environment (ESSIE) directed the operational analysis and the review of software for analysis of roundabouts. Researchers in the Department of Urban and Regional Planning (DURP) at UF completed the remaining tasks, including the review of literature, the evaluation of the gaps in knowledge about the use of roundabouts, the review of national and state policy documents and the preparation of the final report.

1.4 Scope of Work and Supporting Tasks

Task 1: Literature and Background Review

Literature related to the safety, access management, multimodal transportation (especially for bicyclists and pedestrians), and roadway capacity associated with the use of roundabouts was reviewed. The research team also examined roundabout policies and guidelines from other states. Documentation on the design and placement of roundabouts is summarized in a separate spreadsheet. In a task that was completed after the literature review, national and state policies and guidelines on roundabout safety, access, and capacity were reviewed and documented; the results of this policy scan are incorporated into a separate chapter that reports the results of this research.

Task 2: Evaluation of Gaps in Knowledge Regarding Use of Roundabouts

In this task, the research team critically evaluated available literature and state policies and identified the gaps in knowledge regarding the use of roundabouts, especially as they apply to safety, access, operations, and roadway capacity. The literature is used to define a typology of contexts in which roundabouts are implemented. This typology expands the definition of context from urban, suburban, and rural, to include other factors that affect safety, access, and roadway capacity such as access points (three vs. four); number of lanes (one vs. two); isolated roundabouts vs. roundabouts in a corridor; roundabouts in a residential neighborhood vs. roundabouts in commercial districts or near interchanges; and other factors as defined in the literature. This task assessed and documented the state of the art in access management in the vicinity

of roundabouts (for example, policies and assessment regarding the positioning of driveways close to a roundabout, or on a link connecting two roundabouts). This evaluation also developed a typology of contexts in which roundabouts are implemented, and this was used in the selection of roundabouts for detailed investigation in the operational analysis.

Task 3: Safety Analysis

The research team used the typology developed in the previous step to understand safety issues associated with roundabouts. The safety analysis determines whether crash causation is related to the presence of specific driveway and median characteristics and provides recommendations for access design features with respect to safety.

Subtask 3-1: Identify Potential Study Locations

In this task, FDOT's Roadway Characteristics Inventory (RCI) was used to identify the location of all roundabouts in the state. The RCI includes roadway data for all state roads and a few off-system roads. The 2011 RCI has 219 locations classified as "roundabouts." An additional 64 roundabouts were found using Google Map for a total of 283 roundabouts throughout the state. Using satellite images already captured from Google Maps for each of these locations and Google's Street View, all potential study locations were identified for use in the safety and operational analysis. For the safety analysis, all roundabout locations were used to understand the general trends in crashes near roundabouts and a larger sample was used for specific analysis. As described below, the operational analysis considers several factors used to select roundabouts for detailed study: the presence of significant mainline and driveway traffic, and the proximity of the roundabouts to driveways and/or median design features, as well as commercial or mixed residential and commercial land use areas.

Subtask 3-2: Create Condition Diagrams, Collect Field Data, and Estimate Driveway Traffic

Using a combination of Google Earth, Bing Maps, and Google's Street View, scaled condition diagrams of each potential location identified in the previous subtask were constructed in MicroStation. Each site was visually inspected to collect information on the land uses associated with adjacent driveways, as well as to verify existing geometric conditions. The information collected includes land use types (e.g., restaurants, gas stations, apartments, etc.), number of units, year established, and where applicable, number of employees, floor space, number of gas pumps, and other related context information. The land use information was then used to estimate driveway traffic using the Institute of Traffic Engineers (ITE) Trip Generation Manual.

Subtask 3-3: Review Police Reports and Compile Crash Information

Hardcopies of police reports documenting up to five years of crashes that occurred within the functional area (500 feet) of each selected roundabout location were downloaded from a geographic information system (GIS) currently being developed by Dr. Ilir Bejleri of the UF DURP. Crash data from police reports were extracted, including crash location, crash type, crash severity, vehicle type, driver's age, lighting conditions, and other contributing factors. Additionally, the illustrative sketch and description of each crash was recorded. Since the construction date of some of the locations was not available and the geometric conditions have changed over time, police sketches and descriptions were used to further verify, to the extent possible, that geometric conditions did not change over the study period. In those cases where police reports indicate geometric changes, crashes that occurred before the changes were excluded as were crashes not directly related to the roundabout.

Subtask 3-4: Construct Collision Diagrams and Perform Safety Analysis

In this subtask, crash information compiled previously was used to construct a collision diagram for each study location. From these diagrams and the associated crash characteristics, crash patterns as they relate to driveway and median design features were identified. These patterns were further analyzed based on vehicle type, time of day, lighting condition, driver age, estimated driveway traffic volumes, and other factors, to identify the causes of over-represented crashes. The statistics were also stratified by crash injury level to determine the severity of the crashes. A sample of the questions the analysis attempted to answer includes:

- Do specific driveway and median conditions (e.g., proximity of driveway and median opening to roundabouts; direct vs. indirect driveway connection) contribute to certain types of crashes involving access traffic?
- Does the presence of driveways and median openings result in more severe crashes?
- Is safety affected by certain geometric characteristics of roundabouts when combined with specific driveway and median openings?
- Are there a significant number of crashes involving pedestrians near roundabouts?
- How have pedestrian crossings been affected by driveway locations?

Based on the results of the analysis done here, specific recommendations on driveway and median design features near or at roundabout locations are made. This task documents the results of the safety analysis and provides information about how safety considerations affect the context in which roundabouts are placed.

Task 4: Analysis of Selected Field Roundabout Sites

In this task, the research team identified several roundabout sites in Florida for direct study and analysis. Traffic operations potentially affected by driveways and medians approaching and exiting the roundabout, were studied. The results of this analysis were compared with the findings of Task 1. During peak operating times, between two and four hours of video data were collected at each roundabout location.

Task 5: Development of Recommendations for Incorporating Access Management into Florida Practice

In this task, the research team took the results of the literature review and analysis of gaps in knowledge and made recommendations on how to incorporate access management into roundabout design in Florida. This includes recommendations for additional research, and changes to FDOT's *Access Management Tools*, *Median Handbook* and *Driveway Information Guide*.

Task 6: Assessment of Primary FDOT-Utilized Software Tools for Roundabout Evaluation

As appropriate, FDOT regularly implements various analysis methodologies into custom software products, and recommends the use of certain software products that implement FDOT-approved analysis methodologies. For example, FDOT supports the development of custom software for traffic operations and level of service analysis (i.e., LOSPLAN). LOSPLAN is generally intended for planning and preliminary engineering analyses, and employs deterministic, macroscopic analysis techniques consistent with the HCM. For traffic analysis scenarios involving a high level of complexity, the microscopic, stochastic simulation program CORSIM (corridor simulation) is generally recommended. As FDOT has decided to adopt the HSM methodology for safety analysis, the current capability of HSM in analyzing and predicting the safety performance of roundabouts was assessed, and potential application gaps were identified and recommended for HSM implementation.

In this task, an assessment of the primary FDOT-utilized software tools was made. This assessment focused on the current suitability of these software tools to assist with the evaluation of the issues previously identified. Where they may be deficient, recommendations were made on how to improve these tools to make them more effective for the evaluation of roundabouts and access management.

Task 7: Preparation of Draft and Final Reports

The draft final report was prepared and submitted for review by the FDOT Systems Planning Office and the Research Center staff. The draft final report was reviewed for grammar, clarity, organization, and readability prior to submission to FDOT for technical approval. Toward the end of this task, a meeting was organized with the staff of the Systems Planning Office to discuss the findings and recommendations, and the draft final report. The report was also distributed to other researchers and practitioners with expertise in the design and deployment of roundabouts. The research team prepared a revised final report based on the comments received by the panel, and submitted it to FDOT and the technical review and project implementation panel.

1.5 Organization of the Report

This report is organized into eight chapters beginning with the Introduction. Chapter Two contains the literature review that introduces the concepts of roundabout and access management; examines the prior studies and reports on the similar topics; and identifies gaps in knowledge. Chapter Three describes the methodologies utilized in this research. Chapter Four describes the review of national and state guidance regarding roundabouts, access management and the combination of roundabouts and access management. Chapter Five reports the finding from the safety analysis. Chapter Six discusses the findings from the operational analysis and explores the software that is available for use in analysis of roundabouts and access management. Chapter Seven discusses access management in the roundabouts, incorporating a comparison of the information found in the literature review and in the state guidance, including what has been implemented in the State of Florida, to make recommendations for further research and guidance to improve Florida guidance documents on roundabouts and access management. In Chapter Eight, the research is summarized.

Chapter Two: Literature Review

2.1 Overview

This review of prior research has two parts. First, the available literature regarding the use of roundabouts, especially as they apply to safety, roadway capacity, and access is summarized. Next, a summary of the state-of-the-art in roundabout practice is developed, including an evaluation of gaps in knowledge regarding research about roundabouts and access management.

The literature review is organized around scholarly and practice-based research on roundabouts, roundabout capacity, roundabout safety, and access management. Of particular interest in this section are articles that address access management and multimodal transportation, especially for bicyclists and pedestrians. The literature defines a typology of contexts in which roundabouts are evaluated, including: the type—urban, suburban, and rural; the number of access points—three and four; the number of lanes—one and multi-lane; the number of roundabouts—one and corridor; and location of the roundabouts—residential, commercial, mixed-use, and interchanges.

2.2 Roundabouts

Prior literature differentiates modern roundabouts from traffic circles or circular intersections. The traffic circle, introduced in 1905, can be seen as a precursor to roundabouts in the United States (Jacquemart, 1998). In the *Roundabouts Guide, 2nd edition*, Rodegerdts et al. (2010) defined three types of circular intersections: rotaries, neighborhood traffic circles, and roundabouts.

The United Kingdom initiated the modern roundabout in 1966 with the “give-way” rule for entering traffic, by allowing circulating traffic to continue driving in roundabouts rather than yielding to entering vehicles. The first modern roundabouts in the United States were constructed in 1990, and were based on the professional design experience of other countries, particularly Australia and the United Kingdom. The difference between roundabouts and other circular intersections is the “give-way” rule that prioritizes traffic circulating in the roundabout or the smaller neighborhood traffic circles (Rodegerdts et al., 2010).

2.2.1 Modern Roundabouts. This project focuses on the modern roundabouts; throughout the document the term “modern roundabouts” is used interchangeably with “roundabouts” as defined here. Roundabouts can be described as:

circular intersections with specific design and traffic control features. These features include yield control of all entering traffic, channelized approaches, and appropriate geometric curvature to ensure that travel speeds on the circulatory roadway are typically less than 50 km/h (30 mph). Thus, roundabouts are a subset of a wide range of circular intersection forms (Rodegerdts et al., 2010, p. 5).

With this definition, three key features of roundabouts are distinguished from those of other forms of traffic circles, such as rotaries, mini-traffic circles, and other non-modern roundabouts. These features are the yield-at-entry rule, channelized approaches, and geometric curvature designs to slow down the speed. Aty and Hosni (2001) added two other characteristics of modern roundabouts that are important to this research: prohibiting both parking on the circulating roadway, and pedestrian activities on the central island. Figure 1 and Figure 2 show the features of a typical roundabout and the differences and similarities between single and multi-lane roundabouts.

2.2.2 Geometric Design

Geometric elements of the roundabout include: inscribed circle diameter, entry width, circulatory roadway width, central island, entry curves, exit curves, pedestrian crossing location and treatments, splitter island, stopping sight distance (SSD), intersection sight distance (ISD), vertical considerations, and bicycle provisions.

2.2.2.1 Key Features and Dimensions. According to the second edition of *Roundabouts, An Informational Guide* (Rodegerdts et al., 2010), the key features of roundabouts include the central island, splitter island, circulatory roadway, apron, yield line, accessible pedestrian crossings, bicycle treatments, and landscaping buffer. Furthermore, the roundabout dimensions address the inscribed circle diameter, circulatory roadway width, approach width, departure width, entry width, exit width, entry radius, and exit radius. Additional explanations about each feature are included in Appendix A.

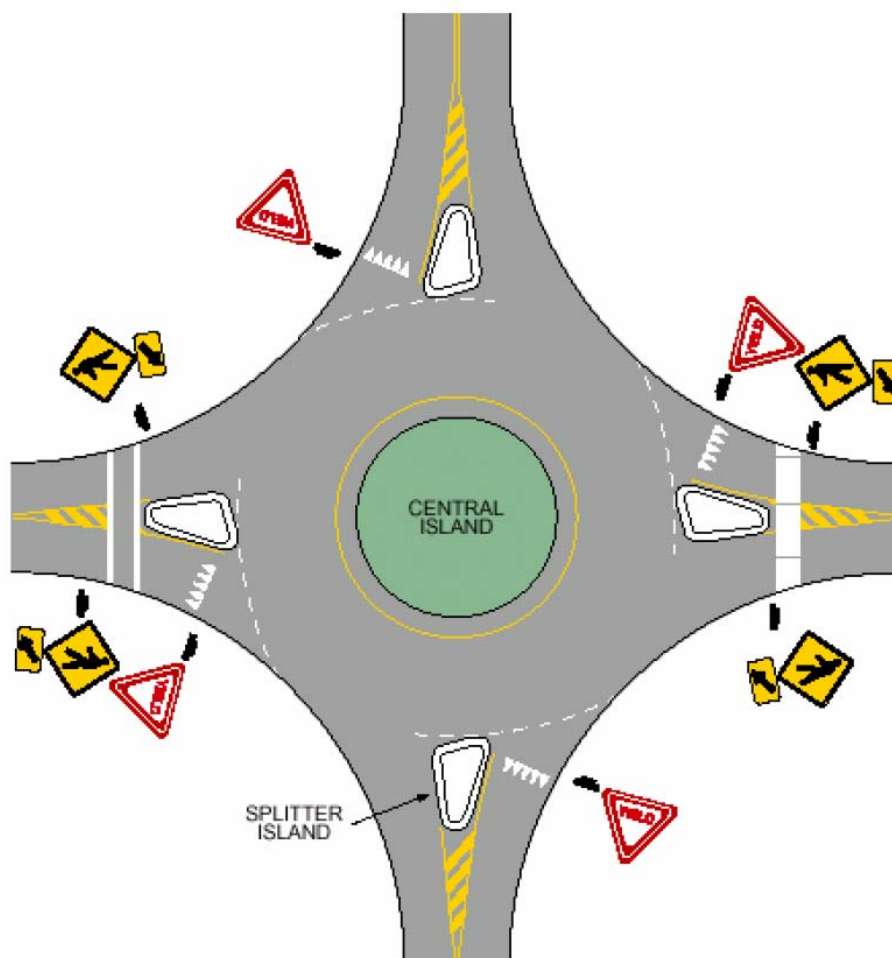
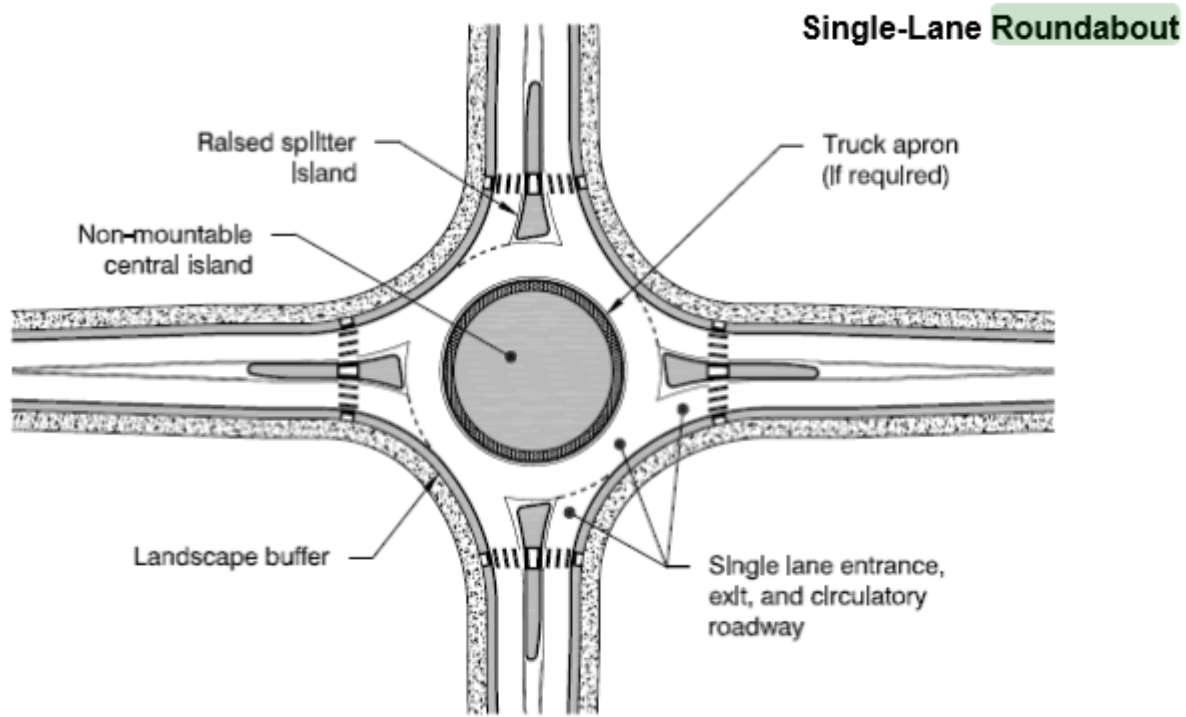
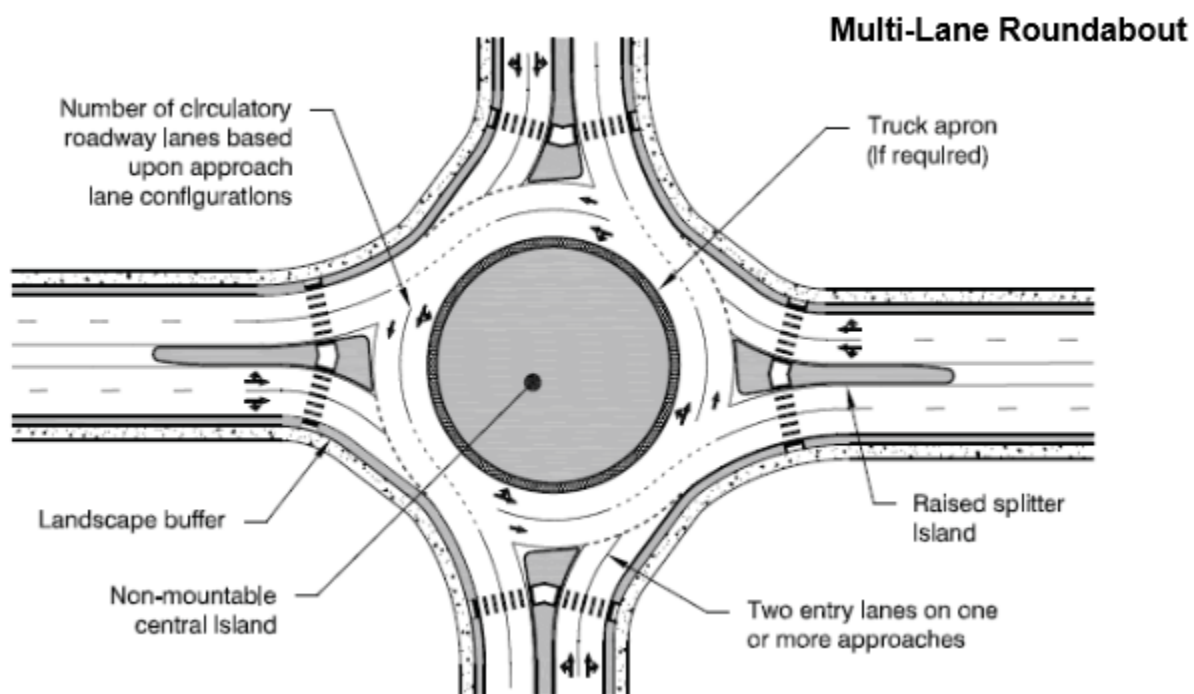

Figure 1. Geometric Design Features of a Typical Modern Roundabout (FDOT, 2007)



(a) single-lane roundabout (FDOT, 2007, p. 2-21)



(b) Multi-lane roundabout (FDOT, 2007, p. 2-21)

Figure 2. Geometric Design Features of a Typical Modern Roundabout: Single-lane (a) and Multiple-Lane Roundabouts (b)

Design specifications and guidelines for each individual geometry component are provided in national and state guides (e.g., Gluck and Lorenz, 2010; FDOT, 2007; IowaDOT, 2010; Maryland, 2012; and WisDOT, 2013). The first elements that should be defined and optimized in the geometric design of a roundabout are the size, position, alignment, and arrangement of approach legs. Then, other details of geometry can be determined. Each type of roundabout (single, double, multi-lane, rural, or mini) has specific design guidelines, so it is difficult to standardize them. However, based on NCHRP 672, *Roundabouts, An Informational Guide* (Rodegerdts et al., 2010, pp. 6-8), every roundabout design should meet the following set of objectives:

1. "Slow entry speeds and consistent speeds through the roundabout by using deflection;"
2. "The appropriate number of lanes and lane assignment to achieve adequate capacity, lane volume balance, and continuity of lanes through the roundabout;"
3. "Smooth channelization that is intuitive to drivers and results in vehicles naturally using the intended lanes;"
4. "Adequate accommodation for the design vehicles;"
5. "A design that meets the needs of pedestrians and bicyclists;" and
6. "Appropriate sight distance and visibility" (Rodegerdts et al., 2010, pp. 6-8).

2.2.2.2 Entry and Exit Design. Since access management focuses on land uses and driveways adjacent to a roundabout, the two most obvious locations to examine access in relation to geometric design are the entry and the exit. Entry width should be designed to accommodate the design vehicle while ensuring adequate deflection (Layton, 2012, 44). Typically, the minimum width for a single-lane entrance on a state facility roundabout is 14 ft. When a curb is present on both sides, and the splitter island is longer than 33 ft., the minimum width should be 17 ft. (the criteria for passing a stalled vehicle).

Deflection is defined as: "the change in trajectory of a vehicle imposed by geometric features of the roadway" (Rodegerdts et al., 2010, Glossary, p. 3). It is usually designed for the entrance to a roundabout and should support the design principles of deflection to slow drivers down, although it can be significantly affected by the location and spacing of driveways before the roundabout. Deflection is an important aspect of roundabout design, both for safety and capacity. Aspects of deflection in roundabouts force the driver to reach the intended circulating speed range (usually between 20-30 mph), and increase the driver's awareness of traffic before entering the roundabout, while in it, and after exiting the roundabout.

Deflection is often achieved with the use of reverse curves on the entrance to a roundabout. According to the Oregon DOT, a reverse curve "should have the same or a slightly larger radius than the radius of the curved path that a vehicle would be expected to travel through. The speed of the curve of the approach should be no more than 10 mph faster than the maximum negotiation speed through the roundabout" (Taekratok, 1998, p. 45).

To slow traffic and indicate the upcoming presence of a roundabout, splitter islands or lane markings are used in conjunction with reverse curves. If driveways or other access points are placed too close to a roundabout, proper levels of deflection can be inhibited, potentially affecting the operation of the roundabout and making it less safe for users. To avoid this, roundabout splitter islands should extend back from the roundabout entry at a length adequate to hinder driveway access movements that could cause safety or queuing concerns.

2.2.2.3 Sight Distance. According to Taekratok (1998, p. 52), "visibility is an important concern in the design of roundabouts." Several aspects of sight distance should be evaluated to determine adequate spacing distance and access to a roundabout: SSD, decision sight distance, ISD, minimum access spacing, and recommended spacing. SSDs are calculated based on approach speeds and other factors, and can be found in the HCM 2010. Evaluations about sight distance and conflict points are significant factors in relation to the safety of a roundabout and adjacent land uses. See Figure 3 and Figure 4, below.

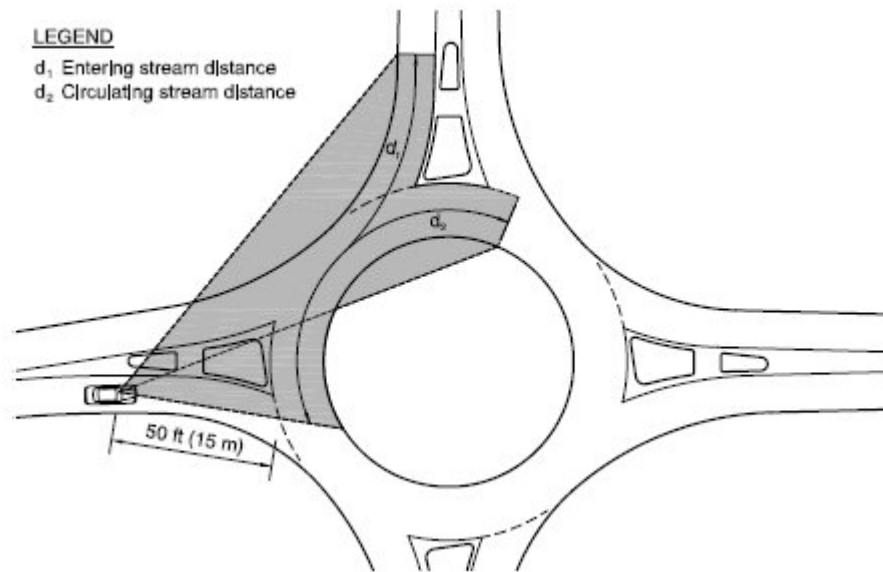

Figure 3. Intersection Sight Distance (FHWA, 2006, p. 18)

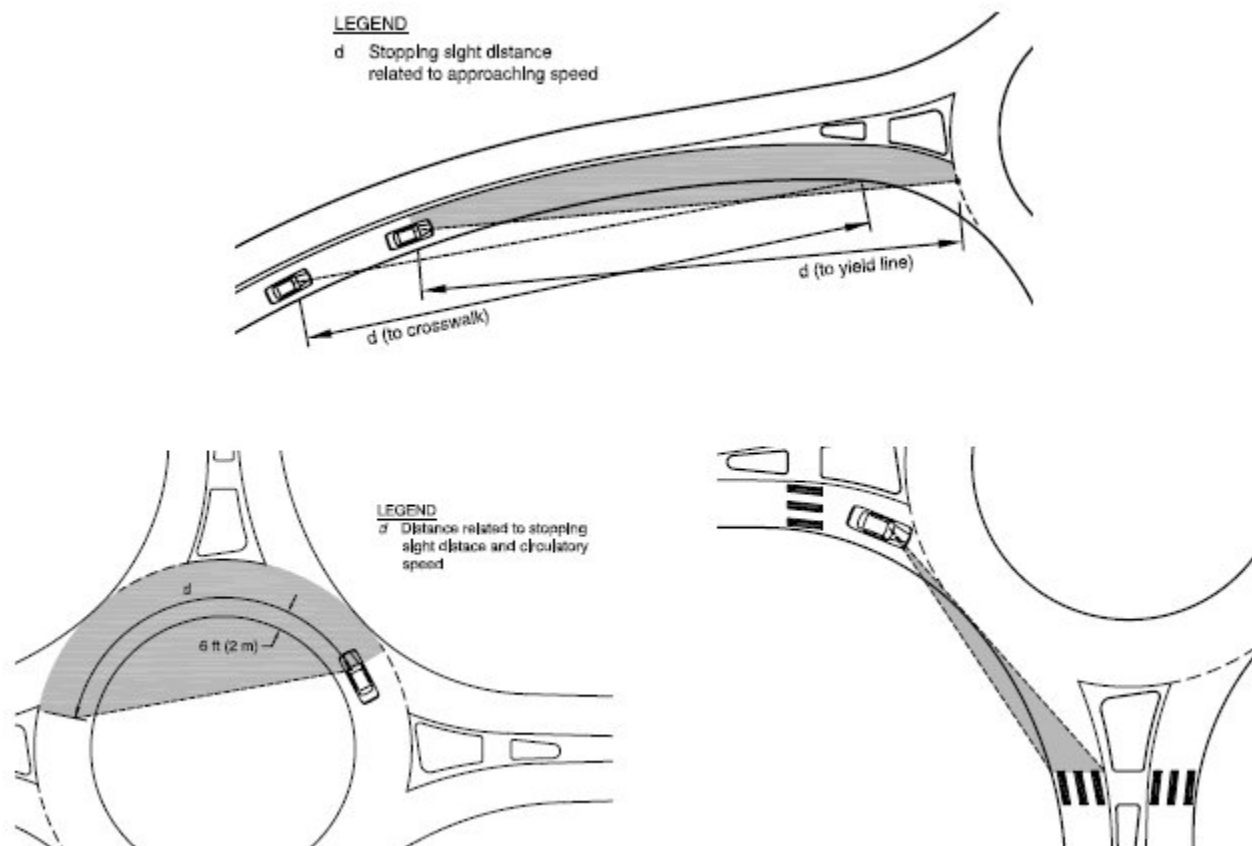

Figure 4. Stopping Sight Distance (FHWA, 2006, p. 19)

2.2.3 Contexts of Roundabouts

2.2.3.1 Single-Lane Roundabouts. Converting controlled intersections into a roundabout, especially single-lane roundabouts, has received a lot of research attention because of the safety effects. As an example, Flannery, Elefteriadou, Koza and McFadden (1998) studied the safety and operational

performance of five single-lane roundabouts that were converted from stop-controlled intersections. Overall, the study locations experienced a reduction in crash frequencies, crash rates, and control delay. The authors compared control delay measured in the field with the delay predicted by SIDRA, a software package that analyzes at-grade controlled intersections and roundabouts. Roundabout designers should carefully consider the number of lanes planned for inclusion in a roundabout before initiating its design, construction, and implementation. Studies show that fewer crashes occur in single-lane roundabouts than double-lane roundabouts (Wang, Ong and Rakha, 2013; Mahdalová, Seidler and Cihlářová, 2010). However, two-lane roundabouts were found effective regardless of the degree of demand. Also, an increase in the total number of crashes occurs at three-lane roundabouts that were converted from signalized intersections (Mcintosh, Redinger and Bagdade, 2011).

2.2.3.2 Urban and Rural Roundabouts. Designing for roundabouts in urban areas can be challenging when the impacts of driveway access and nearby intersections are taken into account. The size and geometric design of a roundabout is highly dependent upon the nature of the area (urban vs. suburban), speed limits, roadway nature, or number of lanes, and it may be complicated by the need to ensure access for other land uses in neighboring urban areas (Isaacs and Barrett, 2003).

It is easier to make an evaluation for access management for rural areas for roundabouts as compared with urban areas because there are fewer spatial constraints. The greater distances between traffic intersections result in less interaction with the roundabout from neighboring driveways. However, because roadways in rural areas typically have higher speed limits than those in urban areas, traffic safety issues must be seriously considered regarding access and safety.

2.2.3.3 Urban Roundabouts. Increased safety at roundabouts compared to controlled intersections is a function of reduced speed and fewer potential conflict points (Isaacs and Barrett, 2003). However, higher crash frequency may be caused by inadequate design standards and problematic driver behavior (Sacchi, Bassani and Persaud, 2011). Sacchi et al. (2011) showed that inadequate geometric design, particularly an excessive radius of deflection and a low angle of deviation of the entering approach, contributed to 60% of the crashes in the Italian cities of Novara and Trento. Another issue regarding the design and construction of urban roundabouts is the accommodation of different types of road users, especially people with disabilities and visually impaired pedestrians (Isaacs Barrett, 2003). When it comes to roundabouts and people with disabilities, the literature focuses more on visually impaired pedestrians because those individuals have difficulty in identifying when and where to cross a roundabout leg due to the lack of detectable warnings.

2.2.3.4 Rural Roundabouts. A conversion to roundabout use along rural two-lane roadways reduced crash frequencies, crash rates, injury crashes, and angle crashes (Isebrands, 2009b; Isebrands and Hallmark, 2012). The two studies defined rural areas as “completely rural or less than 2,500 urban population, not adjacent to a metro area.” In the first study, Isebrands (2009a) studied 17 roundabouts, the majority of which were converted from two-way-stop controlled (TWSC) intersections with flashing yellow or red warning lights. The study found a 52% reduction in total crashes, a 67% reduction in crash rate, an 84% reduction in injury crash frequency, and an 89% reduction in injury crash rate. Especially significant is the fact that fatal crashes were reduced from 11 in the before-period to none in the after-period. In addition, the frequency of angle crashes was also reduced by 86% (Isebrands, 2009b). In another study, Isebrands and Hallmark (2012) evaluated the safety effectiveness of converting 19 intersections that were located on high-speed rural roadways into roundabouts. Specifically, there was a 62 to 67% reduction in total crashes and an 85 to 87% reduction in injury crashes. Moreover, angle crashes were significantly reduced by 91%.

2.2.3.5 Roundabouts Within a Corridor. Roundabouts interact with other streets as part of larger corridors, often with other roundabouts or other traffic control devices such as signalized intersections. Street systems should be developed to circulate and distribute traffic to manage access to “land uses in the

area with a minimal impact on the mainline and crossroad” (Layton, 2012, p. 3). For special events, which may exceed suitable design-hour conditions for the roundabout and other traffic devices in the corridor, the design of access facilities to special event land uses should take into account increased delays, queues, safety impacts, and larger than normal spacing standards (Layton, 2012). Project NCHRP 03-100 *Evaluating the Performance of Corridors with Roundabouts* was recently completed on this topic; the final report the final report has been accepted and will be published in the NCHRP series (see TRB, 2014)

2.2.4 Comparing Roundabouts to Other Types of Intersection Traffic Controls

The review of national and state guidance on roundabouts and access management suggest that operations of roundabouts are similar to unsignalized intersections. HCM 2010 mentions that “[t]he operation of roundabouts is similar to that of two-way stop-controlled intersections. In roundabouts, however, entering drivers scan only one stream of traffic—the circulating stream—for an acceptable gap.” (TRB, 2010a, p. 4-14). Also, “roundabouts discharge vehicles more randomly, creating small (but not necessarily usable) gaps in traffic at downstream locations” (p. 8-5). These gaps are different than signalized intersections, a characteristic shared with all-way stop controlled (AWSC) intersections.

2.2.4.1 Roundabouts vs. Stop-Controlled Intersections. Right-angle collisions are the most common crash types at AWSC intersections. Roundabouts are considered to be unfavorable at locations where traffic flow on approach legs is unbalanced, at locations where space is limited, and at locations near persistent bottlenecks (Vlahos et al., 2008). When roundabouts are properly located, they provide better performance (i.e., reduced delay and increased capacity) compared to AWSC intersections with similar traffic volume and right-of-way limitations (Vlahos et al., 2008, pp. 88). In addition, total crash frequencies, total crash rates and injury crash rates may be reduced after stop-controlled intersections are converted to roundabouts (Flannery, 2001). These studies were conducted as before-and-after safety evaluations using video-recorded data for four hours during the peak periods at eight single-lane roundabouts with a minimum of two years of data after the roundabouts were built (Flannery, 2001).

2.2.4.2 Roundabouts vs. Signalized Intersections. Many prior studies agree that converting signalized intersections to roundabouts results in a better safety performance (Saccomanno, Cunto, Guido and Vitale, 2008; McIntosh et al., 2011; Jensen and Apes, 2013; Gross, Lyon, Persaud and Srinivasan, 2013; Uddin, Headrick and Sullivan, 2012; Wang et al., 2013; and Dixon and Zheng, 2013). However, specific conditions such as geometry, traffic volumes, and approach speed are related to safety performance. First, the conflict in the signalized intersection is affected by geometry and volume (Saccomanno et al., 2008). In turn, fewer rear-end crashes occur on roundabouts than on signalized intersections (Saccomanno et al., 2008). Jensen and Apes (2013) made a similar argument when they concluded that central islands that are more than two m (6.6 ft.) high, had a better safety performance compared to lower central islands. However, Dixon and Zheng (2013) found that the width of the circulating lane and the radius of the inscribed circle were insignificant in the models. Most likely, this conclusion is due to the similarity of geometric features in the study comparison of Oregon roundabouts. Saccomanno et al. (2008) and Gross et al. (2013) make similar arguments, and agree that the safety benefits of roundabout conversion declines with an increase in traffic volume in terms of total crashes (Gross et al., 2013). Safety improvements were also documented when intersections with high approach speeds were converted to roundabouts (Jensen and Apes, 2013). Observations show a significant safety benefit for injury crashes with roundabout conversions; even in cases where overall crash frequency increases (i.e. some multilane roundabouts), there are consistent, notable decreases in severe crashes (Gross et al., 2013).

2.3 Access Management

Access management is defined as “the systematic control of the location, spacing, design, and operation of driveways, median openings, interchanges, and street connections to a roadway” (TRB, 2003, pp. 3). Much

of access management is achieved through policy and governance, unlike design strategies mandated by national guidelines for other aspects of transportation design and planning. Access management is highly context-sensitive; however, the *Access Management Manual* does offer guidance and general considerations for use. Though access management can often be thought of as simple regulation of driveways and access onto roadways, the term encompasses a significantly more diverse range of principles, particularly in the context of roundabout design and planning. Access management represents a toolbox of strategies that municipalities, planners, and engineers can employ to provide mobility to users of the roadway system while also ensuring access to properties in use, surrounding and adjacent to the roadway. For access management, “safety, capacity, continuity, and connectivity of the roadway network are key” (Williams and Levinson, 2008, p. 26). Clear connections exist between access design, capacity, and safety, since access management has several implications on some aspects of roadway systems (Williams and Levinson, 2008).

Access management, as applied to transportation planning in general, enables access to land uses while providing significant benefits to “motorists, bicyclists, pedestrians, transit riders, business people, government agencies, and communities” (Rose et al., 2005, p. 4). According to Frawley and Eisele (2005, p. 3), access management has three goals: to improve safety and mobility, to provide reasonable access to developments, and to promote local government partnerships. It can also be defined as “a set of tools used to balance the needs of mobility on a roadway with the needs of access to adjacent land uses” (Frawley and Eisele, 2005, p. 2). According to the TRB Access Management Committee, the ten key principles of access management are:

- Provide a specialized roadway system
- Limit direct access to major roadways
- Promote intersection hierarchy
- Locate signals to favor through-movements
- Preserve the functional area of intersections and interchanges
- Limit the number of conflict points
- Separate conflict areas
- Remove turning vehicles from through traffic lanes
- Use non-traversable medians to manage left-turn movements
- Provide a supporting street and circulation system

Access management, in the context of roundabouts, seeks to define how roundabouts relate to adjacent land uses, particularly the supporting street and circulation system, driveways and other access points to the roadway, and entering and exiting the roundabout, as well as movement within it. Since both the use of roundabouts and the study of access management are relatively new in the United States at both the national and state levels, little literature exists regarding the application of access management to roundabout design and planning.

2.3.1 Access Management Elements

Even though geometric design elements do not regulate access management directly, they greatly influence the operation of and access to the roundabout for users and neighboring land uses and play a significant role in the spacing of driveways and nearby intersections. As seen in Figure 8, the distance between driveways affects the number of conflict points for potential vehicle collisions.

2.3.2 Spacing Standards and Roadway Classifications

According to the Access Management Guidebook, NCHRP Report 548 (Rose et al., 2005, p. 39), higher function roads commonly have fewer access opportunities. Similarly, local streets maximize access to residences while supporting less through traffic. However, a basic principle to determine the access level is

the proposed function of the roadways. The Access Management Guidebook also shows that, as the proportion of through traffic increases, access decreases. For example, freeways have very limited controlled access while local streets provide full access.

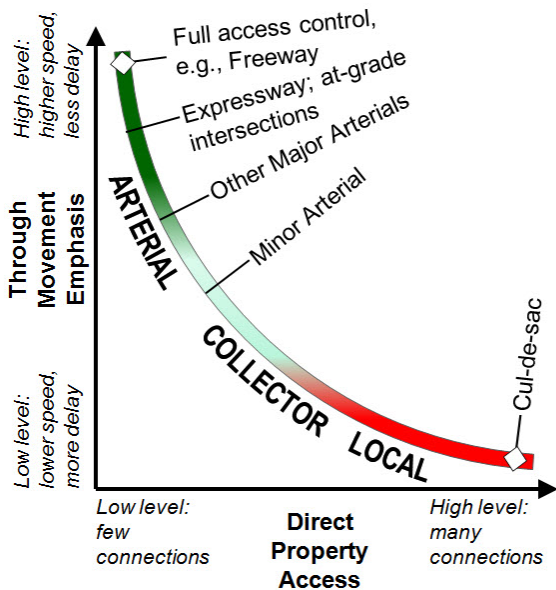

Functional Hierarchy

J. L. Gattis

Figure 5. Access and Road Classification

The Access Management Guidebook (Rose et al., 2005) proposes roadway classification definitions based on characteristics (Rose et al., 2005, p. 49) such as functional classification, travel distance of motorists (e.g., short vs. long trips), nature of the travel (e.g., through vs. local), travel speeds, land use, location of the roadway facility (e.g., urban vs. rural), and physical characteristics of the roadway (e.g., divided vs. undivided). In addition to these characteristics, the planning and design elements included in the access management for each roadway classification are the following:

- Permitted and prohibited access locations;
- Driveway design and spacing;
- Corner clearance;
- Median opening design and spacing;
- Signal location, spacing, and coordination;
- Turn-lane location and design;
- Auxiliary-lane location and design; and
- Service/frontage road location and design.

In addition, according to Demosthenes (2007), roadway design and traffic operations intersect with access management and land use design (see Figure 6).

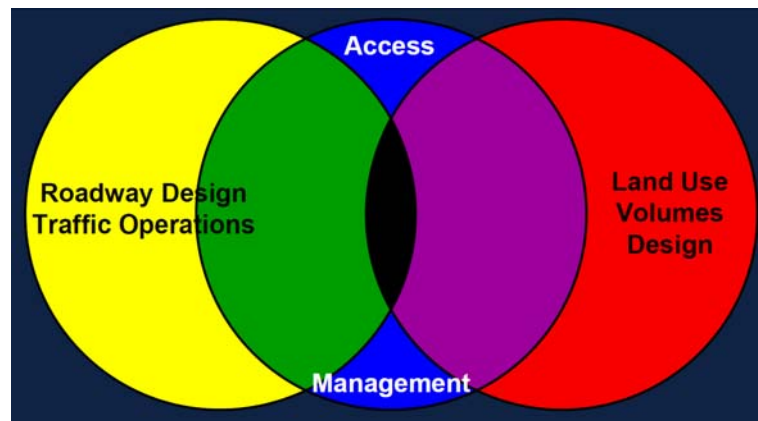

Figure 6. Relationship between Access Management, Roadway Design, Traffic Operations and Land Use (Rose et al., 2005)

2.3.3 Access Management Mechanisms and Intersection Controls

According to the Access Management Guidebook, NCHRP Report 548 (Rose et al., 2005), the most reliable methods of access management for general highway management intersection controls include: acquisition of access rights; access management regulations; policies, directives, and guidelines; land development regulations; geometric design; and development review/impact assessments (Rose et al., 2005, pp. 8-10).

2.3.3.1 Acquisition of Access Rights. Local municipalities can acquire rights to properties that adjoin or are adjacent to roundabouts to maintain access. If the location of a roundabout would block access to a neighboring property, sometimes the municipality may purchase the property and provide financing to help the owner relocate to an alternate location with adequate access (Rose et al., 2005). In other circumstances, however, driveways may remain in close proximity to a roundabout, or even in the middle of a roundabout, as seen in some roundabouts in Wisconsin (M. Johnson, Personal communication, February 7, 2013).

2.3.3.2 Access Management Regulations. Most municipalities include transportation design policy regulations as part of access management standards. These are often based upon national and state standards, although they can voluntarily go into further detail to address issues of context or of local transportation patterns. These are common for traditional stop-controlled and signalized intersections, and are becoming increasingly popular to address roundabout design and planning issues within a locality. Agencies which frequently use roundabouts generally have internal consensus about the types of contexts in which roundabouts are appropriate and where to manage access (P. Demosthenes, Personal communications, March 14, 2013).

2.3.3.3 Policies, Directives, and Guidelines. Comprehensive planning and zoning designations should recognize the role of context sensitive transportation facilities, which may include incorporating minimum spacing standards, and address any unique characteristics of the specific roundabout in policies. The relevant local government or agency should designate the appropriate land use controls and comprehensive planning guidelines, because national policy always includes exemptions (P. Demosthenes, Personal communications, March 14, 2013).

Comprehensive plans should include regulations and design guidelines for access management of traffic control devices. When considering future expansion of certain corridors, alternative traffic control designs such as interchanges or roundabouts require more planning and design considerations than a corridor that of only signalized intersections (Layton, 2012).

The physical expansion of intersections should be examined in comprehensive plans, specifically the number of travel lanes, auxiliary lanes, high-occupancy vehicle lanes, transit ways, modifications to existing interchanges, and planned new interchanges. Each of these projected changes requires additional right-of-way considerations for the municipality. In these cases, Layton (2012, p. 4) argues that the municipality should insure property for expansion, noting that protective buying may be more cost-effective than purchasing the property in the future.

2.3.3.4 Geometric Design. Geometric design for roundabouts should acknowledge the need for roundabout traffic to be distributed to avoid a traffic queue in the roundabout, and ensure access to neighboring properties. In local traffic design regulations and policies, design guidelines should be included that ensure both mobility and access to neighboring properties (Schroeder, 2011).

Evaluation of the land use and geographic contexts of the roundabout is a key. The optimum spacing between urban roundabouts within a downtown urban core could differ from that of rural roundabouts on county roads. Minimum spacing and geometric design of the roundabout must allow for weaving distance and a queue length set at a comfortable operating condition (Layton, 2012, p. 5).

2.3.3.5 Sight Distance. The most pertinent guidelines for sight distance relating to access management are those of the external approach exit and the circulating roadway. The external approach sight distance is the distance a driver has to travel from the moment of approaching the yield line of the roundabout entrance to any entrance path. According to Taekratok (1998), “a driver who is approaching the yield line should have a clear line of sight to approaching traffic entering the roundabout from an approach immediately to the left, for at least a distance representing the travel time equal to the critical gap. A minimum distance is 70 m (230 ft.)” (1998, p. 38).

Drivers entering the roadway from a driveway or access point should be able to see vehicles upstream on the roadway to ensure a safe turn. For instance, the spacing and location of the driveway closest to the roundabout should enable a driver exiting that driveway to be able to turn onto the roadway with a clear view of vehicles approaching and exiting the roundabout. This applies to driveway access points for both the entering and exiting sides of the roundabout.

While the previous example takes into account location and sight distance with no queue, the effects of queues must also be considered with regard to sight distance. An examination of stopping distance and queue length should be considered when determining minimum spacing between a driveway access point and an intersection (Layton, 2012).

2.3.3.6 Development Review/Impact Assessments. One of the most important ways access management can be controlled within a municipality is in the development review process. Even if a roundabout design claims to follow access management principles, it is the responsibility of the municipal or regional traffic engineer to review the design and policies to ensure the design does achieve the stated goals and ensures access to neighboring land uses.

2.3.3.7 Implementing Mechanisms. Agencies need to work together across the board to implement access management mechanisms. These entities include state agencies, state legislatures, metropolitan planning organizations (MPOs), regional planning agencies, local planning agencies, and local elected officials. Rose et al. (2005) identify access management implementing mechanisms, classified by authority,

agency policy, access management, advocacy, management accountability, project programming, and project development, and the implementing agency. Collectively, their work reinforces the importance of the wide range of state and local policies and guidance on access control, land use and site plan review, driveway and other permitting standards and processes, funding for corridor preservation, design standards, and area-wide and corridor access management plans.

2.3.4 Impact of Roundabouts on Access Management

For the most part, the small body of existing literature on access management and roundabouts suggests they may have performance characteristics superior to signalized intersections. Roundabouts enhance the achievement of access management goals in multiple ways: maintaining the continuity of the roadway's flow, improving safety, reducing congestion, balancing mobility and access, and by extending the life of infrastructure (personal communications, Mark Johnson, February 7, 2013). The differing operational characteristics of roundabouts can provide versatility and flexibility in the application of access management techniques: less queuing, slower speeds at entry and exit, consistent speeds, reduced speed differentials, geometric flexibility, and driveway/intersection spacing flexibility. In some cases, roundabouts may also provide increased capacity at intersections, reducing the need to expand entire roadways. Physical geometric characteristics of roundabouts can also alter access management patterns, changing the side of street and driveway access spacing needs and requirements. Often, driveway access and spacing can be easier to plan because of less queuing, slower speeds, and easier decision making.

In response to the scarcity of literature on the topic, Kansas State University (KSU) studied the impact of roundabout installation on business access. Russell, Landman and Godavarthy (2012) conclude that the operational characteristics of roundabouts allow businesses to be located much closer to intersections than do traditional, signalized intersections (Russell et al., 2012, p. 16). In traditional, signalized intersections, queued traffic at red lights for through traffic and turn maneuvers can block access to businesses. With proper access management of roundabout and flowing traffic, "roundabouts can be designed with a commercial or business entrance directly off the roundabout" (Russell et al., 2012, p. 16). Johnson and Isebrands (2008), reach the same conclusions as Russell et al. (2012), that the operational characteristics of roundabouts provide "low delay and improved safety, provides excellent mobility, ingress, and egress through equal opportunity for lefts, through movements, and U-turns" (Johnson and Isebrands, [2008] as cited in Russell et al., 2012, p. 16).

2.3.4.1 Business Access. In several cases, roundabouts have increased access to businesses. In the previously mentioned study, Russell et al., (2012) found that 76.9% of businesses in Topeka, Kansas classified the impact of the roundabouts as fair, good, or very good (Russell et al., 2012, p. vi). In addition to interviews with Topeka business owners, simulation studies of the roundabout installation depicted significant reductions in delay and queuing for all traffic movements. In their study, Russell et al., (2012) referred to several business owners who said they owed their success to the construction of the roundabout. Prior to the roundabout, heavy traffic and queues had been discouraging people from making left turns in and out of businesses. However, after the roundabout was installed, traffic delay was reduced and drivers were able to make left turns more easily and access the adjacent businesses more frequently (Russell et al., 2012, p. 7).

In Golden, Colorado, the introduction of a series of roundabouts proved more efficient in managing traffic flow and created a corridor that slowed traffic and allowed pedestrians to access many businesses along the corridor (Ariniello, 2004). Mark Lenters, president of Ourston Roundabout Engineering, found roundabouts had a positive influence on business access in a number of locations, including (Lenters, n. d.): Linville Road in Brown County, Wisconsin; South Golden Road in Golden, Colorado; Lee Road in Brighton, Michigan; numerous intersection in Carmel, Indiana; Vail Interchanges in Vail, Colorado; Rocky Mountain Avenue in Loveland, Colorado; and Avon Road; Avon, Colorado.

However, roundabout construction, like all intersection construction, is notorious for inhibiting access to adjacent properties and businesses during that period. Decreased access during this time can contribute to negative connotations of roundabouts, even though access will return to normal or even improve once construction is completed.

2.3.4.2 Access Points. Several studies find that roundabouts are successful when the “reorganization” of access points is part of the roundabout design and engineering process. The aforementioned case study from Golden, Colorado involved a corridor that was described as being an “unpleasant travel corridor” with wide roads, poor safety conditions, a center turn lane, and “numerous unorganized access points” (Russell et al., 2012, p. 9). In evaluating different options, the city favored the roundabout selection because it “would provide better access options and better pedestrian access” than traditional traffic signals (Russell et al., 2012, p. 10). After the construction of four roundabouts in place of signalized intersections and after making significant streetscape improvements, the corridor was cited as a “vibrant community corridor,” with “improved business access,” including better pedestrian access to businesses, improved safety, and a 6% increase in retail sales tax revenue (Russell et al., 2012, p. 10). A description of the corridor and its characteristics is presented below:

South Golden Road is a typical suburban strip commercial corridor. The installation of four roundabouts within this half-mile long arterial has resulted in slower speeds, but lower travel times and less delay at business access points. ... [S]ales tax revenues have increased 60% since installation of the roundabouts, and 75,000 square feet of retail/office space has been built. In Golden, Colorado, businesses have said, “Yes, roundabouts are good for business.” (Ariniello, 2004 in Russell et al., 2012, p. 12).

2.4 Operational Effects of Roundabouts

In general, operational aspects of roundabouts can be assessed in terms of capacity and the level of service (LOS), which combines several measures of effectiveness such as delay and queue length. The following design aspects have an impact on the operations of roundabouts: geometric design of roundabouts; traffic flow and driver behavior; placement of driveways near roundabouts; and series of roundabouts.

2.4.1 Effect of Traffic Flow and Driver Behavior

The capacity of a roundabout entry decreases as the conflicting flow increases (Rodegerdts et al., 2010). In capacity model specifications, the capacity of a roundabout decreases from the maximum entry flow rate per hour with the increase of the vehicle conflict rate. Additionally, a variety of conditions exist in real-world situations that might affect the accuracy of a given modeling technique. Rodegerdts et al. (2010) summarize these conditions as follows:

- *Effect of exiting vehicles.* Exiting flow at the immediately upstream leg can affect a driver’s decision on whether or not to enter the roundabout.
- *Changes in effective priority.* When the entering flow and circulating flow volumes are both high, a circulating vehicle might adjust its headway to allow entering, and a gap-acceptance model may not give reliable results.
- *Capacity constraint.* This may occur when an approach operates over capacity. During this condition, the actual circulating flow is less than the demand resulting from the over-saturated approach. The reduction in actual circulating flow may therefore decrease the capacity of the other affected entries.
- *Origin-destination patterns.* This could cause an unbalanced flow at a roundabout with certain approaches operating over capacity.

2.4.2 Effect of Geometry

Geometric characteristics greatly affect the operation of roundabouts. Roundabouts are normally safer if they are designed to force vehicles to reduce their speed when entering the circulatory roadway. On the other hand, low speeds decrease roundabout capacity. Therefore, geometric design should be balanced between safety and operational requirements (Rodegerdts et al., 2010). Generally, the operational performance of a roundabout is determined by its geometric design, along with the traffic volume using the roundabout at a given time.

Geometric elements that influence operations include entry curves and width, circle diameter, circular roadway width, exit curves, central and splitter islands, stopping and ISD, bicycle provisions, sidewalk treatments, parking considerations, bus stop locations, and right-turn bypass lanes (Rodegerdts et al., 2010). Many of the aforementioned geometric parameters depend on the design vehicle and the accommodation of heavy vehicles, bicycles and pedestrians. However, all are essential, and small changes to even one could result in significant changes to the overall roundabout operation performance. Geometry also dictates the number of lanes that are required to facilitate the traffic demand and affects drivers' perception of travel time, their entering and circulating speed, and the gap between vehicles.

2.4.3 Operational Analysis of Roundabout

According to the HCM, the capacity of a facility can be defined as “the maximum sustainable hourly flow rate at which persons or vehicles reasonably can be expected to traverse a point or a uniform section of a lane or roadway during a given time period under prevailing roadway, traffic and control conditions.” (TRB, 2010a, p. 4-1).

The HCM defines specific performance measure(s) for each highway facility type. Control delay is used to define the level of service (LOS) at all types of intersections including roundabouts and signalized and unsignalized. Another performance measure is geometric delay, i.e., the additional delay caused by the intersection geometry. For roundabouts, this additional delay is experienced when drivers slow down to negotiate the roundabouts' curvature (TRB, 2010a). Other relevant performance measurements include degree of saturation and queue length.

Besides roundabout performance measures, a few features are common to the modeling techniques to calculate capacity that is incorporated into all analysis tools (Rodegerdts et al., 2010). Modern roundabouts use yield control at approach lanes and drivers must yield the right-of-way to circulating vehicles and accept gaps in the circulating traffic stream. Therefore, the operational performance of a roundabout is directly influenced by traffic patterns and gap acceptance characteristics. Also, the operational performance of roundabouts is influenced by their geometric features (Rodegerdts et al., 2010, pp. 4-3 to 4-4).

One way to construct a roundabout capacity model is through empirical modeling, which uses statistical methodology to model capacity based on observed data (Al-Masaeid and Faddah, 1997; Polus and Shmueli, 1997; Wei, Grenard and Shah, 2011). Typically a research process for creating an empirical roundabout capacity model is to use regression to find the relationship between volume per hour and the geometric characteristics of a roundabout.

Most of the literature related to roundabout capacity models consists of descriptions of analytical methods and types of measurement. The analytical model is primarily based on driver behavior, measured in gap acceptance (Fisk, 1991; Akçelik, Chung and Besley, 1997; Al-Masaeid, 1999; Flannery and Datta, 1997; Polus, Lazar and Livneh, 2003; Hagring, Roupail, and Sorenson, 2003).

2.4.3.1 Gap Acceptance in the Roundabout and Capacity Model. Akçelik et al. (1997) presented a method for estimating the capacity and performance of roundabout entry lanes. This method is based on modeling the gap acceptance process under the adjustment of the characteristics of the approach flows. The author also presented a case study that is an application of the method. The model in this paper combined the concept of overflow queue and signal analogy to analyze the capacity and performance so that it is a good fit for heavy and unbalanced demand cases in real life (Akçelik et al., 1997).

2.4.3.2 Comparison between Different Models and Approaches for Capacity Measurement.

Roundabout capacity can be modeled based on two types of approaches. Lane-based models measure and predict roundabout capacity lane by lane, and can be extremely useful in the case of multi-lane roundabouts with different lane capacities. In contrast, approach-based models combine the entry lanes as an analytical “lane group.” A study by Hagrings et al. (2003) showed that a lane-based model is better than the approach-based model in comparing observed headways. They found the critical gaps for the left and right entry lanes were different and typically larger for the left lanes. However, for the circulating lanes, the critical gaps were found to be similar. Akçelik (2011) concluded that the HCM 2010 model is a unique lane-based model and if calibrated with driver behavior, could be a very accurate model for capacity analysis. Akçelik’s study also shows that the use of VISSIM and SIDRA yielded similar results for control delay and queue length. However, other studies show that VISSIM predicted larger delay values than SIDRA (Yin and Qui, 2011).

2.4.4 Roundabout Capacity under Different Conditions

Various researchers have studied the capacity model for roundabouts under different circumstances. In this research, the context usually addresses the importance of the number of lanes circulating and entering the roundabout, the presence of slip lanes, the specific shape of roundabouts (e.g., turbo), and the approaching flow into the roundabout.

2.4.4.1 Unconventional Roundabout Capacity. Roundabouts with two or more entry lanes can also have different capacity. Lindenmann (2006) concluded that a small roundabout with two-lane entries and a single-lane circulating roadway has a capacity more than 20% greater than those with one-lane entries. Sisiopiku and Oh (2001) determined that a two-lane roundabout is the best design for intersections with high through and left-turning traffic. Their study also concluded that roundabouts could have a higher capacity than signalized intersections (Sisiopiku and Oh, 2001). Another type of conventional roundabout is a turbo roundabout which is a type of modern roundabout with spiral road markings, designated lanes, and raised lane dividers. Therefore capacity for turbo roundabouts can also be different.

2.4.4.2 Roundabouts with Unbalanced Flow. Unbalanced traffic occurs where one approach volume dominates the other approach volume, or there is a significant difference between approach volumes. The capacity model of roundabouts with unbalanced flow conditions was studied and results showed that those with unbalanced flow conditions were significantly different from other roundabouts (Akçelik, 2004; Sisiopiku and Oh, 2001; Valdez, Cheu and Duran, 2011). Sisiopiku and Oh (2001) found that from an operational perspective, unbalanced traffic patterns in roundabouts could sometimes carry higher volumes than traditional intersections.

2.4.4.3 Roundabout Capacity with Slip Lanes. A slip lane in a roundabout facilitates right-turning traffic to reduce delay and increase capacity and safety. Three types of slip lanes are incorporated into roundabout designs: free-flow slip lanes, yield-control slip lanes and stop-control slip lanes. Al-Ghandour, et al. (2012) believed that all slip lane types could reduce average delay in a single-lane roundabout and that a free-flow style slip lane performs the best. The results of these studies showed that the average delay is exponentially related to slip lane volumes. All three types of slip lanes have a significant positive effect

on capacity, with the free-flow slip lane having the most positive effect, followed by yield and stop-control slip lanes. However when pedestrians have priority, a free-flow slip lane can increase roundabout delay by five times if the pedestrian volume and right-turn volume are both high (Al-Ghandour et al., 2012).

2.4.4.4 Roundabouts in series of signalized intersections. The capacity of roundabouts can be dramatically affected by location, as well as the traffic progression before and after the roundabout. Several studies examine the impact on capacity that roundabouts have on a series of signalized intersections. Bared and Edara (2005) found that if a roundabout is within one-quarter mile of a signalized intersection, it results in delays comparable to a fully signalized arterial. Hallmark, Fitzsimmons, Isebrands, and Giese (2010) found that the use of roundabouts in a signalized corridor did not appear to adversely affect traffic flow or operations.

2.4.5 Summary of Roundabout Operation Literature Review

Rodegerdts et al. (2010) summarized how to conduct roundabout operational analyses as follows:

- **Data collection and processing.** Traffic data can be collected with live recordings of turning movements in roundabouts, traffic flow in intersections, and origin-destination patterns. Field observation is necessary for measuring some of the operational performance measures such as control delay (Rodegerdts et al., 2010). Data processing includes determining roundabout flow rates by converting turn-movement volumes to roundabout volumes and adjusting for heavy vehicles.
- **Determine study methods and tools.** A variety of methodologies are available for studying roundabouts depending upon the stage in the development of the roundabout. In the earlier stages of analysis, such as planning-level sizing, and preliminary design, the practitioner will use deterministic software or the HCM. In later stages, such as the analysis of the impact of the roundabout on special users, such as pedestrians, or on the transportation system and for communicating to the public, simulation tools become more important. The decision on which method to use is based on the required output and the available data. Rodegerdts et al. (2010) presented a table (see Table 1) specifying the method selection standard.

Table 1. Selection of Analysis Tool (Rodegerdts et al., 2010)

Application	Typical Outcome Desired	Input Data Available	Potential Analysis Tool
Planning-level sizing	Number of lanes	Traffic volumes	Section 3.5 of this guide, HCM, deterministic software
Preliminary design of roundabouts with up to two lanes	Detailed lane configuration	Traffic volumes, geometry	HCM, deterministic software
Preliminary design of roundabouts with three lanes and/or with short lanes/flared designs	Detailed lane configuration	Traffic volumes, geometry	Deterministic software
Analysis of pedestrian treatments	Vehicular delay, vehicular queuing, pedestrian delay	Vehicular traffic and pedestrian volumes, crosswalk design	HCM, deterministic software, simulation
System analysis	Travel time, delays and queues between intersections	Traffic volumes, geometry	HCM, simulation
Public involvement	Animation of no-build conditions and proposed alternatives	Traffic volumes, geometry	Simulation

2.5 Roundabouts and Safety

Safety is one of the primary reasons for the increased use of roundabouts in the United States and around the world. The volume of literature on roundabout safety is quite extensive compared with the available literature on roundabout capacity and access management. NCHRP Report 674 *Crossing Solutions at Roundabouts and Channelized Turn Lanes for Pedestrians with Vision Disabilities* highlights the close relationship between safety and accessibility, particularly in the case of roundabouts (Schroeder et al., 2011). According to Schroeder et al. (2011), “a facility could be considered safe if the crash rate at the facility is low.” Consequently, crash rate is the most frequently used measure to estimate safety in traffic engineering in general, and for roundabouts as well; however, the use of the crash can be a challenge because the crash rate is seldom a linear relationship.

The literature that explores safety as it pertains to modern roundabouts places emphasis on different areas: safety effectiveness, safety of vehicles and vulnerable users (i.e., bicyclists and pedestrians), comparison of the safety performance of roundabouts with other controlled intersections, and other factors related to driver safety. Crash rates based on before-and-after or cross-sectional studies are often used to evaluate safety at roundabouts. Due to the lack of exposure data, the safety of vulnerable road users is often estimated using direct observation. Despite different views about safety and accessibility at roundabouts, most of the literature confirms that modern roundabouts have significant safety benefits for all types of road users.

The FHWA Safety website on roundabouts has considerable information regarding roundabout safety, including several reports and manuals on the application of best safety practices in roundabout design and planning. The most commonly used safety guidebooks include:

- *Roundabouts, An Informational Guide* (Robinson et al., 2000)
- *Pedestrian Access to Modern Roundabouts: Design and Operational Issues for Pedestrians who are Blind* (USAB, 2006)
- NCHRP Report 672: *Roundabouts: An Informational Guide, 2nd Edition* (Rodegerdts et al., 2010).
- NCHRP Report 572: *Roundabouts in the United States* (Rodegerdts et al., 2007).
- NCHRP Report 674: *Crossing Solutions at Roundabouts and Channelized Turn Lanes for Pedestrians with Vision Disabilities* (Schroeder et al., 2011)

2.5.1 Overall Safety Effects of the Roundabouts

In the past researchers have studied the safety performance of roundabouts and compared the findings with other traffic-controlled intersections, such as stop-controlled intersections, and signalized intersections. Most researchers use cross-sectional studies that compare the roundabouts either with previous means of intersection control or with those means of traffic control within an area close to the roundabouts. Safety performance measures or indicators commonly used are crash frequency, crash rate, crash severity, and crash type (Isebrands, 2009b). Specifically, different locations within the roundabout may affect the safety performance of roundabout. According to Arndt and Troutbeck (1998), crashes can be categorized as single-vehicle and multiple-vehicle crashes. For multiple-vehicle crashes, the following characteristics are included: where the crash occurred; whether the vehicle was entering/circulating the roundabout; exiting/circulating the roundabout; whether it was it a sideswipe crash; and other low frequency types of crashes. The locations include departure leg, exit point, approaching rear end, entering/circulating crash, entry point, and sideswipe crashes. Figure 7 illustrates the locations of the types of crashes in roundabouts.

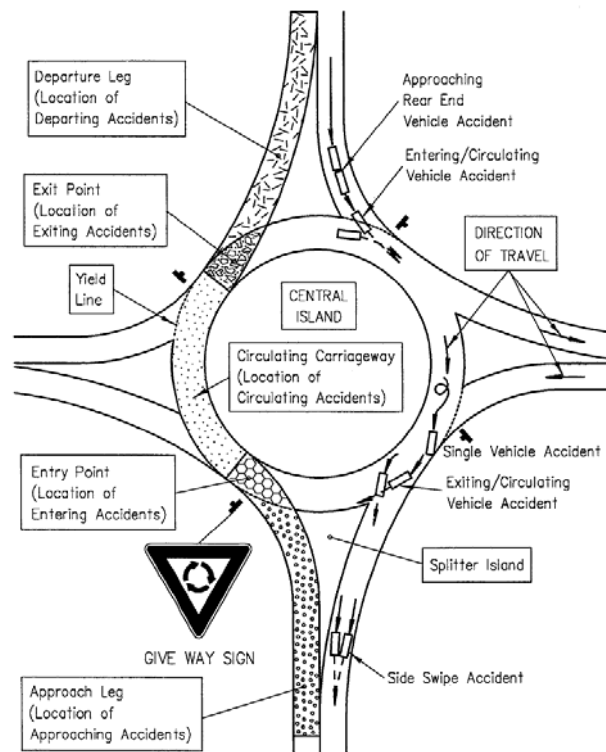

Figure 7. Crash Types on a Typical Roundabout (Arndt and Troutbeck, 1998, p. 28-3)

Previous studies found the magnitude of safety effects ranged from a 17 to 70% reduction in the number of crashes. Flannery and Datta (1996) found an average of a 60-70% reduction in crash frequency for the

safety effect of 13 roundabouts in three states: Maryland, Florida, and Nevada. Retting, Persaud, Garder, and Lord (2001) found that a change to 24 roundabout installations from 20 stop-controlled intersections and four signalized intersections led to a 38% reduction in total crash frequency and a 76% reduction in injury severity. Similarly, Persaud et al. (2001) found a safety effect for roundabouts that led to a 40% reduction in total crash frequency and an 80% reduction in injury severity. Isebrands (2009b) found that roundabouts reduce injury crash frequency and injury crash rate by 84% and 89%, respectively. She (Isebrands, 2009b) also found that roundabouts reduced total crash frequency and total crash rate by 52% and 67%, respectively. De Brabander, Nuyts, and Vereeck (2005) evaluated the crash frequency for 95 roundabouts and 119 comparable intersections in Flanders, Belgium and found a 34% reduction in the number of injury crashes. Similarly, in another study, De Brabander and Vereeck (2007) found that roundabouts resulted in a 39% reduction in injury crashes, a 17% reduction in serious injury crashes, and a 38% reduction in minor injury crashes. Churchill, Stipdonk, and Bijleveld (2010) concluded that roundabouts reduced the number of fatal and serious injury crashes by 76% and 46% respectively. Elvik (2003) found conversion from an intersection to a roundabout resulted in a 30-50% reduction in the total crash rate. The fatal crash rate was reduced by 50-70%.

Despite these generally positive results, not all conversion of roundabouts significantly reduces the number of crash occurrences. For example, Rodegerdts (2007) concludes that the conversion from four-way stop controlled (FWSC) intersections to the modern roundabouts do not appreciably reduce the total and injury crash rates. This study also highlights design features, such as the number of lanes, which were found to perform better than multi-lane roundabouts, which are more sensitive to such characteristics. The result may also be dependent on the previous traffic control type, prior to roundabout construction, and the number of approach legs (Elvik, 2003). Furthermore, placement requirements should be considered before roundabout conversion. For example, roundabouts are considered unfavorable for locations when traffic flow on approach legs is unbalanced, at locations where geometry is limited, and at locations near a persistent bottleneck (Vlahos et al., 2008).

In contrast to the effects of roundabouts on single or multiple automobile crashes, prior studies make various arguments regarding crashes involving vulnerable users, i.e. pedestrians and bicyclists. First, the argument is that roundabout installations reduce safety for vulnerable users (De Brabander and Vereeck, 2007; Daniels et al., 2008). In their meta-analysis study, De Brabander and Vereeck (2007) found that crashes involving vulnerable road users increased by about 28%. Moreover, Daniels et al. (2008) concluded that in built-up areas, crashes involving bicyclists increased by 48%. In built-up areas, bicycle-vehicle crashes at roundabouts that were converted from stop-controlled and signalized intersections increased by 55% and 23%, respectively. Outside built-up areas, the change in bicycle-vehicle crashes before and after roundabout construction was statistically insignificant. A study in Sweden reached several conclusions related to crashes involving bicyclists and pedestrians: (1) single-lane roundabouts are much safer for bicyclists and pedestrians than for multilane roundabouts; (2) for pedestrians, roundabouts are no less safe than conventional intersections; (3) is safer for bicyclist to bypass a roundabout on a bicycle crossing than to travel on a carriageway; and (4) fewer cyclist crashes occur when the central island is greater than 10 m (33 ft.) and when bicycle crossings are provided (Rodegerdts et al., 2006). Other research argues that no significant problems were found for pedestrians at roundabouts (Harkey and Carter, 2006). These different results may be caused by different areas of study, the number of vulnerable users, and type of analysis; at the very least, they reinforce the importance of considering the context of the roundabout in the analysis.

2.5.2 Aspects of Safety Performance of Roundabouts

Several design aspects, such as conflict points, roundabout design, speed, geometry, sight distance, and pavement markings, determine the safety performance of roundabouts. The importance of each of these aspects is explored below.

2.5.2.1 Conflict Points. A conflict point is defined as a location where the paths of two motor vehicles, or a vehicle and a bicycle or a pedestrian path, diverge, merge, or cross each other (Rodegerdts et al., 2010, p. 5-5). The number of potential conflict points could be a surrogate measure of safety; fewer conflict points could result in enhanced safety. Roundabouts have fewer conflict points compared to conventional intersections, with the resulting potential for improved safety. Figure 8 shows the conflict points at a traditional stop-controlled or signalized intersection and at a single-lane roundabout. A traditional stop-controlled or signalized intersection with four legs has 32 conflict points, while a roundabout with four legs has only eight conflict points (Bie, Lo, Wong, Hung and Loo, 2005; Rodegerdts et al., 2010; Stone et al., 2002). By reducing the number of conflict points, roundabouts can increase safety at an intersection (Elvik, 2003; Hyden and Varhelyi, 2000).

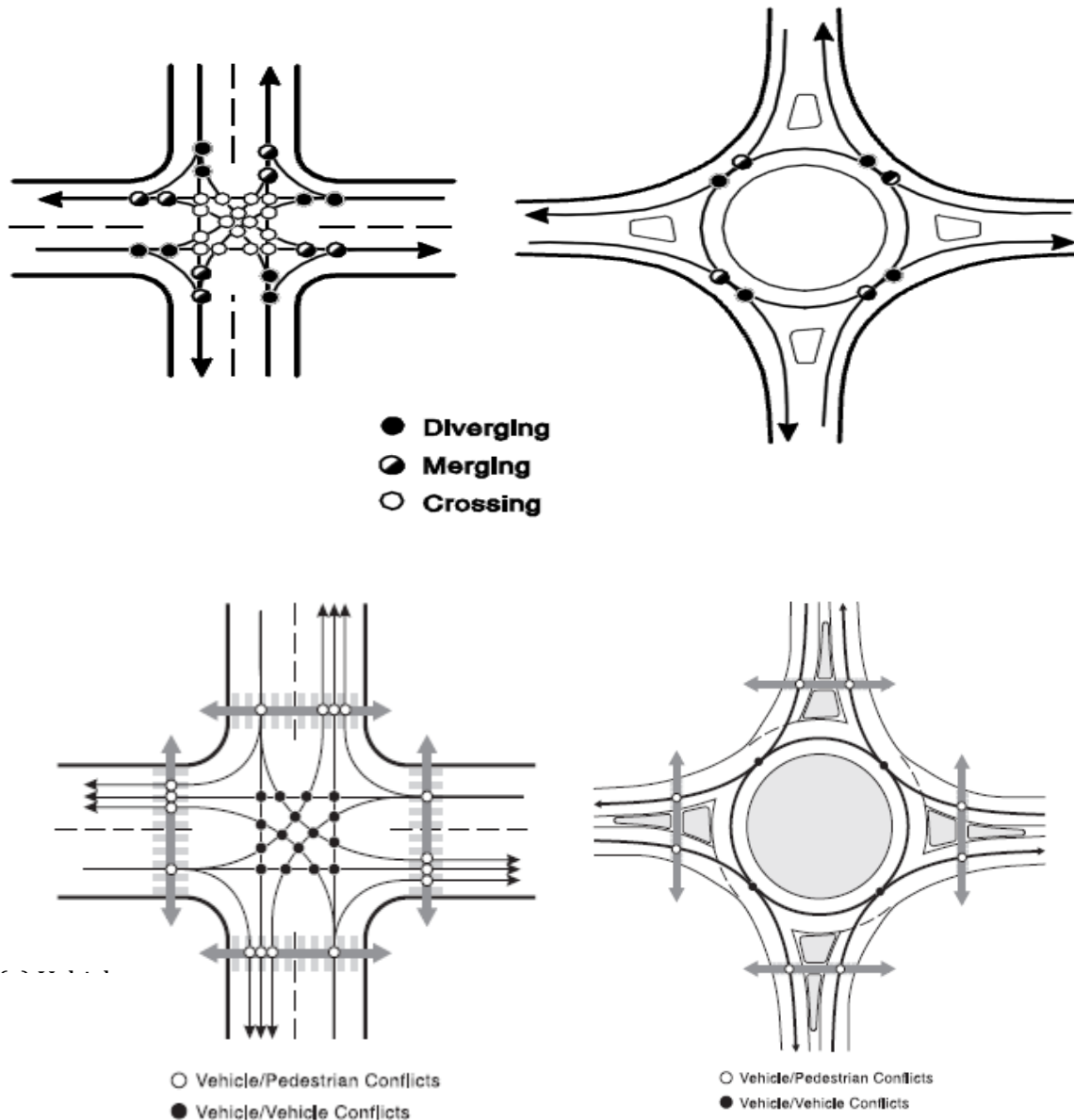

Figure 8. Vehicle Conflicts and Vehicle-Pedestrian Conflicts at Signalized Intersections and Single-Lane Roundabouts (Rodegerdts et al., 2010, Exhibit 5-2, p. 5-7)

The one-way traffic flow through roundabouts gives a sense of ease to drivers when observing oncoming traffic, and has been shown to improve safety by making drivers more cautious (Daniels and Wets, 2005).

Certain crash types, including right-turn, angle, and left-turn crashes are eliminated as vehicles move in one direction through the roundabout. Further, crashes at roundabouts are often less severe; most crashes result in minor injuries or property damage only (Rodegerdts et al., 2010). A desirable roundabout design establishes a high priority on speed reduction and speed consistency (Robinson et al., 2000). Vehicles must be able to navigate the roundabout through a series of turning movements at lower speeds, usually less than 20 mph. Geometric features can also control vehicle speeds. Some of the safety benefits for a good roundabout design include:

- A reduction in crash severity for pedestrians and bicyclists;
- More time for drivers entering the roundabout to make proper decisions, adjust their speed and enter a gap in circulating traffic;
- Safer merges into circulating traffic;
- More time for drivers to detect and correct their mistakes or compensate for the mistakes of others;
- Making intersections safer for novice users; and
- Eliminating left-turn crashes.

When properly designed, roundabouts reduce the speed of vehicles approaching, circulating, and exiting the roundabout. Lower travel speeds reduce the speed differentials among vehicles. Vehicles have low and homogenous relative speeds in roundabouts, forcing traffic to slow down because of lateral displacement (Daniels and Wets, 2005). Consequently, drivers have more time to anticipate and react to potential conflicts. In general, higher speed differentials yielded higher crash rates for total crashes and entry rear-end crash types (Zirkel, Park, McFadden, Angelastro and McCarthy, 2013). As a consequence, speed standards on the roundabouts are necessary (Montella, Turner, Chiaradonna, and Aldridge, 2013). Studies also show uneven traffic flow is a contributing factor to speed variations (St-Aubin, Saunier, Miranda-Moreno, and Ismail, 2013). Research at five roundabouts in Québec, Canada also reported that large and inconsistent speed variation was mainly due to regional differences in design and road use (St-Aubin et al., 2013).

In safety performance models, speed may perform as a surrogate variable in designing roundabouts (Chen, Persaud and Lyon, 2011). After analyzing crash data and approach level data for 33 approaches at 14 roundabouts from eight states, the authors concluded that speed-based models performed better than non-speed based models. After relating speed to geometric features using correlation analysis and calibrating the model, the authors identified the inscribed circle diameter (ICD), and entry width as significant geometric features. Higher approach speeds result in increased crash rates at roundabouts (Mahdalová, et al., 2010)

Furthermore, “relative speeds among adjacent geometric elements should be minimized for optimum safety” (Arndt and Troutbeck, 1998, p. 16). Vehicle speeds could be reduced by “reducing the radius of the approach curve, minimizing the entry, exit, and circulating lane width; better positioning of the entry and departure legs; and increasing the central island diameter” (Arndt and Troutbeck, 1998, p. 13). In this study, other relevant conclusions include: the ideal differential speed between the upstream intersection and the roundabout is about 20 km/h; and larger radii decrease the frequency of single-vehicle crashes, but potentially increase multiple-vehicle crash rate. To keep drivers from cutting into an adjacent lane, this study suggests that the approach roadway shift laterally by 7 m. The author also suggests that the 85th percentile speeds on all the approach legs be limited to about 60 km/h. This can help minimize rear-end crashes. Finally, the entering/circulating vehicle crashes could be minimized by limiting the relative speed between vehicles entering and circulating in the roundabout to about 35 km/h.

The size of the inscribed circle diameter, the entry/exit radii, traffic flow, and geometrical layout influence safety at roundabouts (Mahdalová, et al., 2010). Speed limit also has an effect on safety. For example, higher approach speeds resulted in relatively higher crash rates, especially if the approach speed was

above 70 km/h. Furthermore, the crash rate was found to increase with an increase in the number of approach legs. Daniels, Brijs, Nuyts, and Wets (2011) found that three-leg roundabouts performed less effectively than four-leg roundabouts. The author developed Poisson and gamma-models to predict crashes using 148 roundabouts in Flanders, Belgium. The study also concluded that roundabouts with a cycle path had fewer crashes than those with other bicycle facilities, while those with large central islands had more single-vehicle crashes.

2.5.2.3 Sight Distance. In determining proper sight distances at the roundabouts, designers should consider the ISD, upstream approach sight distance, and circulating sight distance. While an inadequate sight distance is considered unsafe, a greater distance may increase the percentages for total and rear-end crash frequencies possibly because larger sight distances encourage higher speeds (Angelastro, McFadden and Mehta, 2012). The authors developed crash prediction models as a function of average annual daily traffic (AADT) and sight distance attributes to predict total and rear-end entry crashes per year per roundabout approach. The models show that sight distance parameters could better explain the variations of crash frequencies when compared to base models that use AADT as the only predictor. Moreover, exceeding sight distance thresholds increased the risk of crash occurrence and yielded greater speed differentials between the approach and the entry to these roundabouts (Zirkel et al., 2013).

2.5.2.4 Pavement Markings. Several studies examined the impact of different pavement markings on the safety of the roundabouts (Bie et al., 2005; Fortuijn, 2009). The first study compared conventional and Alberta-type lane markings in roundabouts (as shown in Figure 9). Alberta-type marking, also known as spiral marking system, is used for two or more lane roundabouts and includes pavement markings to indicate to drivers at which lane they need to be to exist from the roundabout. A safety analysis was performed using a cell-based model to determine potential conflicts when two or more vehicles are projected to collide in the same cell at the same time interval. Although Alberta-type marking tends to centralize the conflict spots and potentially influence safety, this study finds no statistically significant difference in the safety of roundabouts with conventional and Alberta-type markings.

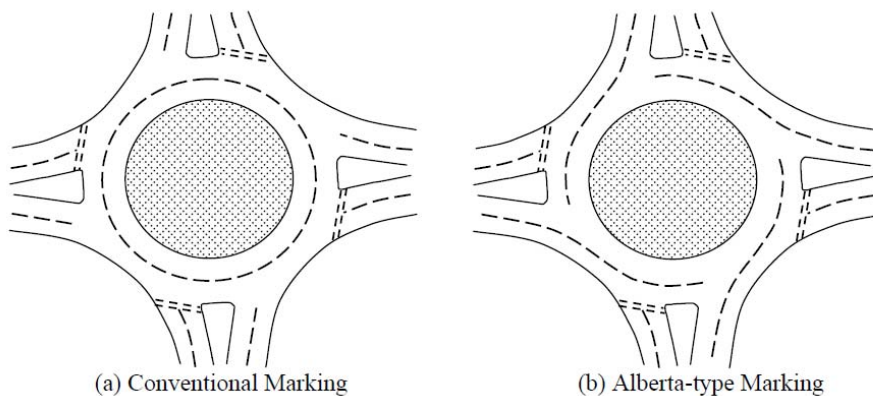

Figure 9. Different Marking Systems (Bie et al., 2005)

In the later study, Fortuijn (2009) reviewed raised lane dividers, also known as turbo dividers, and evaluated their effectiveness in minimizing sideswipe crashes at two-lane roundabouts. Fortuijn (2009) evaluated the new type of design at seven roundabout locations in the Netherlands and found that it reduced crashes by 72%. The roundabouts with turbo dividers are called turbo roundabouts. Turbo roundabouts can be defined as a specific kind of spiral marking roundabout.

2.5.2.5 Crash Types. Different types of crash occurrences determine the emphasis of roundabout geometric design. For example, single crashes at roundabouts may occur when drivers lose control of their vehicles and collide with a part of the roundabout, or as a result of weather-related factors and road conditions. For instance, wet road conditions result in a lower coefficient of friction and collisions with the

apron or curbs of roundabouts. Also, visibility is reduced at night and during foggy conditions. Single-vehicle crash rates are found to be higher at roundabouts with the following geometry: high absolute speeds on a particular geometric element, high differential speeds between adjacent roads and the roundabouts, long curves, and curves that required high values of side friction (Arndt and Troutbeck, 1998). The predominant types of multiple-vehicle crashes include rear-end crashes, crashes involving vehicles entering/exiting/circulating the roundabout, and sideswipe crashes. These crashes are mainly due to high differential speeds between vehicles, or obstruction to drivers' view of other vehicles or the roundabout (Arndt and Troutbeck, 1998).

In single-lane roundabouts, safety could be improved by providing adequate visibility and sufficient right-of-way for good deflection on the center island (Flannery, 2001). By observing crash statistics after the roundabout construction of nine single-lane roundabouts in Maryland, Nevada, and Florida, the author found that 27.3% of total crashes were sideswipes, 24.2% were rear-end crashes with a relative high of 45.5% of total crashes due to a loss of control. This could be attributed to high speeds on entry approaches and possible driver violations. Specifically, safety could be improved at these locations by improving the geometric design of the approaches.

2.5.2.6 Signage. Signage and clear information have a role in improving safety effects. Low safety effects in two-lane roundabouts raised study concerns about the impact of signage (Inman et al., 2006b). The study shows that roundabout users either do not use or do not understand associated signage. Richfield and Hourdos (2013) had a similar concern about safety on two-lane roundabouts and evaluated the impact of changes made to striping and signing at a two-lane roundabout in Richfield, Minnesota on driving behavior. The study found that improper turns and failure to properly yield were the main causes of a majority of crashes. Changes in signage and striping resulted in a 55% reduction in improper turns and a 59% reduction in events where drivers chose incorrect lanes.

2.5.3 Safety for Different Roundabout Users and Modes

Safety is also related to different types of users. In this section, literature review for safety of vulnerable road users, pedestrians, bicyclists, and heavy vehicles are discussed.

2.5.3.1 Vulnerable Road Users. The safety performance of modern roundabouts for vulnerable road users has long been debated. Although several studies have found no significant issues (Harkey and Carter, 2006; Schroeder et al., 2006); vulnerable road users, particularly bicyclists and visually-impaired pedestrians, could encounter potentially unsafe situations at roundabouts. Research results are extremely dependent on the location of the studies. For example, studies from countries outside the United States, particularly Belgium (De Brabander and Vereeck, 2007) and Denmark (Hels and Orozova-Bekkevold, 2006; Møller and Hels, 2008), conclude that the safety of bicyclists and pedestrians worsened after roundabout implementation. This could be because, compared with the United States, pedestrian and bicyclist traffic is significantly higher in these countries.

Crash data of vulnerable road users is limited because fewer crashes are reported. Additionally, pedestrians and bicyclists may tend to avoid roundabouts, resulting in limited exposure. Consequently, studies conducted in the United States on pedestrian and bicycle safety rely primarily on observational, rather than statistical techniques. Safety studies in the United States typically find either no significant issues with roundabout conversions or an improvement in safety for pedestrians and bicyclists (Stone, Chae and Pillalamarri, 2002; Harkey and Carter, 2006; Schroeder et al., 2006).

Even though different arguments exist on the safety effects of modern roundabouts, a majority of the literature concludes that two-lane roundabouts are more dangerous for pedestrians and visually-impaired pedestrians than single-lane roundabouts. Inman, Davis and Sauerburger (2005) proposed additional crossing treatment for visually-impaired pedestrians in two-lane roundabouts. Schroeder (2013) also

concluded that additional treatment was necessary. However, Inman et al. (2006a) found that sound cue treatments do not help and may result in numerous false alarms.

Unlike vehicle crashes where roundabouts resulted in fewer serious injuries, for vulnerable users (i.e., pedestrians, bicyclists, moped drivers, and motorcyclists) the percentages go up. Conversion from a signalized intersection to a roundabout increased the number of fatal pedestrian and bicyclists casualties per serious injury rate from 0.03 to 0.17 (De Brabander and Vereeck, 2007). Their study focused on roundabout intersections with approach speeds of 50 km/h (31 mi/h). Conversion from a stop-controlled intersection to a roundabout resulted in a 14% reduction in injury crash frequency. On the other hand, conversion from a signalized intersection to a roundabout resulted in a 28% increase in injury crash frequency. Similarly, conversion from a stop-controlled intersection to a roundabout increased the number of fatal casualties per serious injury rate from 0.12 to 0.19 (De Brabander and Vereeck, 2007, p. 588).

Conversely, Harkey and Carter (2006) have not found substantial safety problems for pedestrians and bicyclists. The authors used digital video for observational analysis at seven roundabouts. They observed the digital videos and coded different reactions from pedestrians and bicyclists as “normal,” “hesitant,” “retreat,” and “run.” Further, motorist-yielding behavior was coded as “active yield,” “passive yield,” and “did not yield.” The study showed no substantial problems for pedestrians and bicyclists. Nonetheless, the research highlighted the need for a more pedestrian-friendly design of roundabouts in exit legs and the need to provide additional treatments for multi-lane roundabouts.

2.5.3.1.1 Bicyclists. Bicyclists in roundabouts can be treated as pedestrians or as drivers; this distinction influences the number of conflicts experienced by cyclists. Daniels and Wets (2005) added that the details of roundabout design influence the number of conflict points for bicyclists. The number of conflict points increases if bicyclists are treated as drivers due to the speed differential and the difference in visibility between bicyclists and other motorized vehicles (Brown, 1995; Daniels and Wets, 2005; Robinson et al., 2000).

Figure 10 shows four types of alternative treatments for bicyclists at roundabouts: (1) mixed traffic with motorized traffic, (2) adjacent bike lanes, (3) separated bike lanes with priority for bicyclists at crossings, and (4) separated bike lanes without priority for bicyclists at crossings. Alternative (3) was found to be safer than Alternative (4) because motorized vehicles yield to bicyclists when priority is given to bicyclists (Daniels and Wets, 2005). Alternative (3) had a slightly higher number of serious injuries compared to Alternative (4) (Daniels and Wets, 2005). Both alternatives (i.e., 3 and 4) performed better than Alternative (1) and Alternative (2) for injury crashes (Daniels and Wets, 2005). However, specific recommendations were not made due to lack of sufficient evidence.

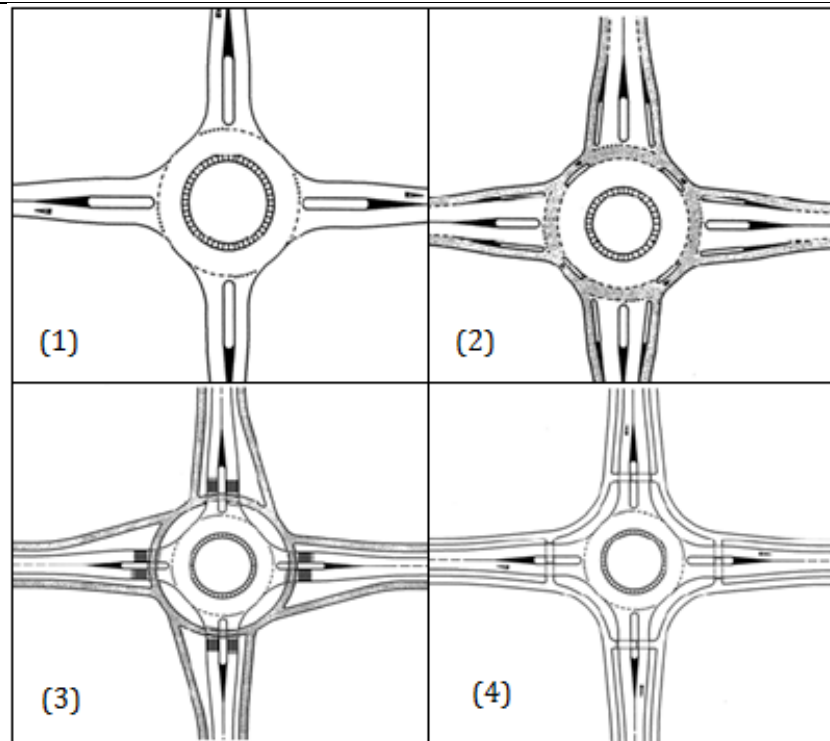

Figure 10. (1) Mixed traffic; (2) adjacent bike lanes; (3) separated bike lanes with priority for bicyclists; and (4) separated bike lanes without priority for bicyclists (Daniels and Wets, 2005, p. 6-8)

Still on the safety perspective of bicyclists, roundabouts in built-up areas performed worse compared with those outside built-up areas resulting in a 48% increase in bicycle crash frequency at roundabouts constructed inside a built-up area. No increase in bicycle crashes was found at roundabouts constructed outside built-up areas (Daniels et al., 2008). Furthermore, the authors estimated a 15-24% increase in severe-injury bicycle crashes. Despite those four alternatives, two other alternatives that were not discussed by the author include treating bicyclists as pedestrians and providing grade-separated crossings at tunnels and bridges.

In contrast, bicyclists appeared to gain more respect from drivers after roundabout construction as the percentage of yielding increased from 13 to 77 (Hyden and Varhelyi, 2000). This study conducted on-site observations with the objective of viewing the interactions between road users at junctions after the roundabout construction. Hyden and Varhelyi (2000) also performed a conflict analysis and found that the frequency of bicycle-vehicle conflicts dropped from 77 to 45, with the expected number of injury crashes per year down from 4.2 to 1.7.

The behavior of violence influenced safety performance. For example, using observation for all bicycle movements and any observed bicycle-vehicle interactions on single-lane roundabouts located in Massachusetts, Berthume and Knodler (2013) found that when the number of bicycles that performed unsafe maneuvers was compared to the total number of bicycles observed traversing the roundabout, about 3% of total bicycle maneuvers were found to be unsafe. In addition, bicycle-vehicle collisions at roundabouts were found to be more frequent when bicyclists underestimated the risk and/or had little knowledge of the relevant traffic rules (Møller and Hels, 2008). The perceived level of risk at a roundabout without a bike facility was higher than that for bicyclists at a roundabout with a bike facility. Additionally, the perceived level of risk was also influenced by age, gender, involvement in a near crash, traffic volume, and whether there is a bike facility. A possible countermeasure to increase the perceived risk and to correct unsafe practices is to implement efficient signage for bicyclists. After generating a model using data

collected between 1987 and 1993 with 1,385 observations and comparing bicycle lanes in roundabouts with and without pedestrian signals, Dabbour and Easa (2008) recommend using pedestrian signals at roundabouts.

2.5.3.1.2 Older population. Clear signage influences safety for older road users (i.e., ≥ 65 years) using a roundabout (Lord, Schalkwyk, Chrysler and Staplin, 2007). The study was conducted using structured interviews and focus groups in College Station, TX, and Tucson, AZ. The participants included 14 men and 17 women. In this study, design elements were reviewed, including advance warning signs, lane control signs, directional signs, yield treatments, and exit sign treatments. A Likert-type scale with seven points was used. Researchers then used the analysis of variance (ANOVA) to understand if there were significant differences between the base condition, countermeasure #1, and countermeasure #2. Table 2 provides a detailed description of the base condition and tested countermeasures.

Table 2. Detailed Countermeasures for Design Elements (Lord et al., 2007, p. 429)

Design Element	Base Condition	Countermeasure #1	Countermeasure #2
A. Advance Warning Signs	The advance warning sign template [W2-6] was used according to the guidelines proposed in the MUTCD (FHWA, 2003).	Two changes were made compared to the Base Condition: (1) a solid black circle was added in the middle of the sign, and (2) a plaque with the text "ROUNDABOUT" was attached below the advance warning sign.	A plaque with an advisory speed of 30 mph was placed below the warning sign used for countermeasure #1 (i.e., the sign with the solid black circle).
B. Roundabout Lane Control Signs	The Base Condition was modeled after the R3-8 series of advance intersection lane control signs (FHWA, 2003).	A solid black circle representing the central island was added to the left lane's route, but not for the right lane's route.	The text "LEFT LANE" and "RIGHT LANE" under the corresponding routes were added to the sign used for the Base Condition.
C. Directional Signs (one-way sign)	The Base Condition shows a central island without any guide signs or special pavement marking to guide traffic circulating inside the roundabout, as per the guidelines proposed by the MUTCD (FHWA, 2003).	A one-way sign (template R6-1) was placed on the central island, positioned to face the centerline of the approaching roadway at a 90° angle. In this position, drivers will see the sign as they approach the roundabout.	The same one-way sign was placed on the central island, but directly in front of the driver's entry point at the gore area rather than facing the centerline of the approaching roadway. This placement puts the sign more directly in the driver's line of sight from the yield line.
D. Yield Treatment	The standard R1-2 yield sign was provided on both sides of the road at the entrance of the roundabout. This condition represents the standard set by Section 2B.10 of the MUTCD (FHWA, 2003).	A yield line consisting of solid white Isosceles triangles was added to the Base Condition.	This treatment included all of the components noted for Countermeasure #1, but added a plaque reading "TO TRAFFIC IN CIRCLE" below the yield signs.
E. Exit Treatment	The Base Condition consisted of placing a street exit sign (based on the D1 series) prior to reaching the exit; the sign was placed between two intersecting streets facing inward toward the traffic in the circle.	The same street exit sign from the Base Condition was used, but was moved onto the splitter island of the intended street exit; this sign still faced inward toward the traffic in the circle.	An arrow pointing to the exit leg was added on the street name sign used for countermeasure #1.

The results of this study for each design element are as follows. A “ROUNDABOUT” legend is preferred as an advance warning sign upstream of a roundabout. Adding directional signs are favored; however, the results for this design feature were not statistically significant. For the yield treatment element, adding “TO TRAFFIC IN CIRCLE” under the YIELD sign was found to be statistically significant. The arrow for exit sign treatment yielded a more positive response from participants.

2.5.3.1.3 Pedestrians. Roundabouts eliminate several potential conflicts for pedestrians as Table 3 shows. However, pedestrian-vehicle conflicts, when they exist, involve high-speed, right-turning, and left-turning vehicles (Daniels and Wets, 2005).

The increase in pedestrian-vehicle conflicts has been shown by several studies (Hyden, 2000; Stone, Chae and Pillalamarri, 2002). The first study examines the effect of roundabout installation at one intersection in Raleigh, NC by conducting three analyses: the pedestrian-vehicle crash histories with and without the proposed roundabout; a statistical analysis for pedestrian-vehicle crashes versus street and intersection characteristics; and a traffic simulation. The researchers used *Paramics* software because it modeled roundabouts explicitly rather than as one-way stop-controlled intersections. The study concluded that the proposed roundabout seemed promising in that there is a 7% reduction in pedestrian-vehicle crashes in the roundabout compared with those on the street or at intersections. In addition, the simulation showed that the proposed roundabout would improve pedestrian safety compared with a FWSC intersection. This is due to fewer conflict points and lower speeds of vehicles. The second study showed that after the installation of roundabouts, the proportion of vehicles yielding to pedestrians increased from 24% to 51%, and the number of conflicts was reduced from 19 to four. Hyden and Varhelyi (2000) observed the number of pedestrian-vehicle conflicts before and after installation of roundabouts using the 30-hour observation period. Additionally, the results also showed that roundabout construction resulted in a reduction in the expected frequency of injury crashes from 0.6 to 0.1.

For design-specific concerns, Furtado (2004) found that roundabouts with central islands that have a diameter greater than 10 m. perform better than those with smaller diameters. Furthermore, the author made the following recommendations: (a) the minimum offset from the yield line to the crosswalk should be 7.5 m., (b) a detectable warning surface delineating the travel lane from the refuge area should be installed, and (c) signing and pavement marking treatments for crosswalk facilities should be provided. They then point out the advantages and disadvantages of roundabouts for pedestrians, as shown in Table 3.

Table 3. Advantages and Disadvantages of Roundabout for Pedestrians (Furtado, 2004)

<i>Advantages</i>	<i>Disadvantages</i>
<ul style="list-style-type: none"> • Vehicle speed is reduced as compared to other intersections • Pedestrians have fewer conflict points than at other intersections • Splitter islands and resulting pedestrian refuge areas allow users to focus on one direction of traffic at a time • Crossing movement can be accomplished with less wait time than at conventional intersections that have multiple protected phases 	<ul style="list-style-type: none"> • Vehicle traffic is yield controlled; therefore, traffic does not necessarily stop and it could cause pedestrians to hesitate • May cause anxiety in pedestrians who are not confident about judging gaps in traffic • Crossing locations and setbacks from the yield line often result in longer travel distances for pedestrians • Not widely used in North America, providing significant challenges for the visually impaired

In evaluating the safety of roundabouts, pedestrians with visual disabilities require special consideration. Even though issues of visually-impaired pedestrians at roundabouts have been discussed, until recently there had been no extensive research. To fill this gap, Ashmead, et al., (2005) conducted a study to

compare six normal-sighted pedestrians and six completely blind pedestrians as they crossed a two-lane roundabout. They found that visually-impaired pedestrians are more susceptible to dangers when crossing a roundabout. Also, visually-impaired pedestrians' wait time was longer than that of sighted pedestrians. The study was simulated in Nashville, TN. Participants with normal vision walked around once with an experimenter who pointed out the same features that were described to the visually-impaired pedestrians. The experimenter only intervened as a safety measure. The study showed that the sighted participants did not need any intervention from the experimenter. However, there were 10 instances where the visually-impaired pedestrians needed intervention because they didn't realize they were walking into a potentially dangerous situation. Also, out of the 144 total crossings, there were 15 instances where the visually-impaired pedestrian began to cross and then aborted the crossing.

Visually-impaired pedestrians may have problems in crossing modern roundabouts because they may have the following difficulties: locating the crosswalk within the roundabout; identifying the direction of crosswalk alignment that might be perpendicular to the sidewalk; deciding when the traffic is continuous, and identifying whether a vehicle is yielding; and following the path of crossing alignments and cross multiple lanes through the end of the crosswalk (Schroeder et al., 2006). The curved geometry of modern roundabouts often forces visually-impaired pedestrians to be familiar with how to cross in these circumstances, as opposed to traditional intersections. Since most roundabouts do not have traffic signals, the task of identifying gaps in traffic at roundabouts is quite difficult for visually-impaired pedestrians. Modern roundabouts have continuous traffic and high noise levels that add to the difficulty of visually-impaired pedestrians in determining whether the vehicles have yielded, stopped, or continued.

The total number of crashes involving people with disabilities increased after the construction of roundabouts; however, crash severity dramatically decreased (Singer and Hicks, 2000). Singer and Hicks (2000) also reviewed the challenges in designing a modern, pedestrian-friendly roundabout in Towson, MD. The challenges included the unusual layout of the roundabout; difficulty in accommodating people with disabilities and complying with the Americans with Disabilities Act (ADA); the availability of alternate routes, and liability issues. The authors provided insights on how the Maryland State Highway Administration could address these challenges. They involved various stakeholders in the development of the roundabout, conducted driver and pedestrian education programs, and provided additional information to the public, such as Braille maps.

In response to those issues, Schroeder et al. (2006) tested additional treatments for single-lane modern roundabouts which included sound strips, a pedestrian-actuated flashing beacon, and a combination of the two treatments. For two-lane roundabouts, the authors tested a raised crosswalk and pedestrian signal with Pedestrian Hybrid Beacon (PHB). In this study, Schroeder et al. (2006) used the degree of risk in crossing the roundabout as a performance measure. They used a pre- and a post- within-subject experimental design where the same visually-impaired pedestrians crossed the roundabout in both pre-test and post-test scenarios after the roundabout construction. In the before-and-after study, the authors used a simulation of crossing the roundabouts in which 16 people participated. The study finally concludes that a single-lane roundabout does not pose significant difficulties for visually-impaired pedestrians. This is due to low vehicle speeds, yielding from a majority of drivers, properly installed detectable warning surfaces and the availability of O&M specialists. However, to significantly reduce pedestrian delay at two-lane roundabouts, additional crossing treatments are required.

To further understand specific treatments for two-lane roundabouts, Inman, Davis and Sauerburger (2005) tested whether rumble strip-like devices and pedestrian yielding signs would encourage drivers to yield more for pedestrians. Inman et al. (2006a) conducted two experiments on a controlled and treated course with seven severely visually impaired individuals. Data for each experiment was collected for 1.5 hours every afternoon for a period of two weeks. Performance measures such as correctly detecting a stopped vehicle, failure to detect the stopped vehicle, false alarms, and the number of correctly detected departures

of stopped vehicles were recorded. The results of the study suggested that sound cues on the pavement increased the proportion of double-yielding drivers and decreased the time for visually impaired pedestrians to detect yields; however, false alarms were not affected. The *Yield to Pedestrian* signs, once installed, increased drivers' yielding acts from 11.5% to 16.7%. However, since false alarms are still a problem, the authors concluded that the two treatments did not have a sufficient level of safety improvement to be implemented in two-lane roundabouts: yet, they remain effective in the case of single-lane roundabouts.

2.5.3.2 Heavy Vehicles. If roundabouts have not been designed properly they may inhibit the safe and efficient movement of large trucks due to roundabout design constraints (Park and Pierce, 2013). Using an online survey, the authors synthesized trucking industry observations regarding the challenges experienced by commercial truck drivers while approaching roundabouts. The main issues identified included the need for larger roundabout circumferences, more education for drivers of passenger vehicles, and a reevaluation of roundabout design. About 73% of respondents believed that roundabouts were more problematic for large trucks compared to other types of controlled intersections. Motor carriers commented on roundabout navigation problems that are unique to large trucks, specifically, small roundabout circumferences, design features that cause damage to trucks, and safe interaction with passenger cars. When asked to propose potential solutions, motor carriers wished that roundabouts could better accommodate large trucks without sacrificing safety and operational efficiency.

Daniels, Brijs, Nuyts, and Wets (2010) conducted a study to explore the crash severity at roundabouts using data from 1,491 crashes that occurred at 148 roundabouts in Flanders, Belgium. The analysis period varied from location to location based on data availability. The minimum period was 3 years, the maximum 10 years and the average across all locations was 8.03 years. They developed a model for heavy vehicles that included trucks, trailers, buses, and tractors. Each roundabout experienced an average of 1.22 annual injury crashes; meanwhile, the heavy vehicle crash rate was found to be 0.09 annual crashes per roundabout with a variance of 0.02. Furthermore, a total of 18 single-vehicle crashes were found by this 7 years study to involve heavy vehicles with one fatality and two severe injuries per year. Likewise, 97 multi-vehicle crashes involved heavy vehicles with no fatal or severe injuries.

2.5.4 Methods in Roundabout Safety Analysis

Common methods used to analyzing the safety effects of roundabout include descriptive analysis using descriptive statistics and chi-square statistics, empirical observation, generalized linear model, odds-ratio and meta-analysis, ESE process, and empirical before-after study.

2.5.4.1 Average Mean (Descriptive). Safety evaluation of roundabouts can be obtained using a simple before and after approach. Isebrands (2009b) conducted a before-and after analysis for 17 high-speed rural intersections using a descriptive method which calculating total crash frequency, crash rate and crash severity in five states: Kansas, Maryland, Minnesota, Oregon, and Washington State. Data were obtained from crash records and average daily traffic (ADT) at the study locations. Specifically for crash rate, crashes per million entering vehicles (MEV), was used as a measure of exposure. Figure 11 displays the before-and-after crash frequency statistics at each of the 17 locations.

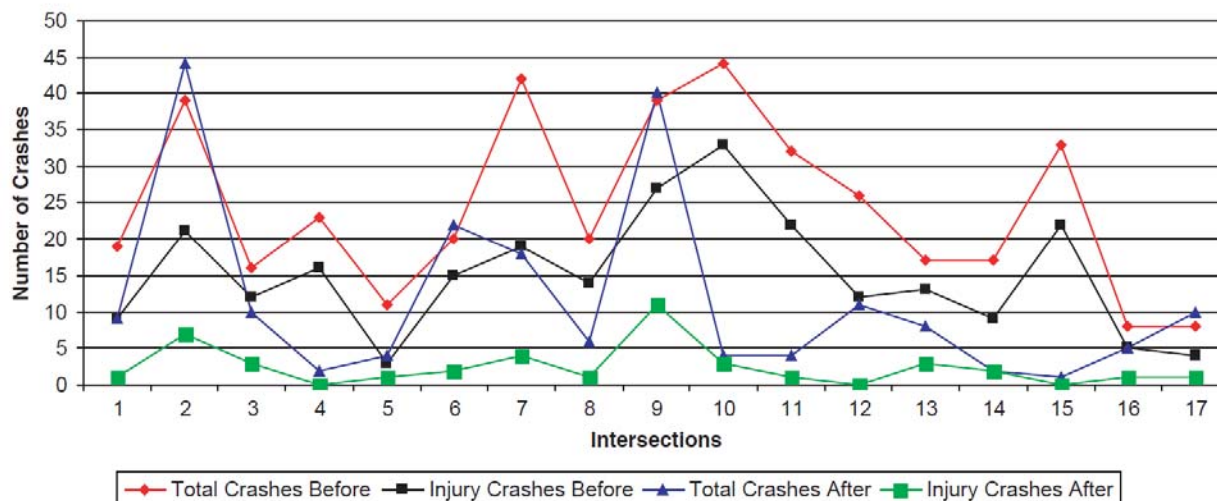

Figure 11. Crash Frequencies in Roundabouts (Isebrands, 2009b)

2.5.4.2 Chi-Square Statistic. Furthermore, the chi-square statistic and a normal approximation test may be used to see the relationship between retrofitted modern roundabout and traffic crashes (Flannery and Datta, 1996). The authors considered crash frequency and the mean of crashes as performance measures. They used crash data before and after the retrofitted periods for each location. To understand whether the before retrofitted conditions are different from those of the after conditions, the authors used a Chi-square test with $\alpha = 0.05$, six locations, and five degrees of freedom. The result indicated that, at a 95% level of confidence, there is a significant difference before and after the construction of roundabouts. Figure 12 gives the data used in the Chi-square analysis.

Group	Site Number					
	1	2	3	4	5	6
Before	1 (1 yr)	3 (1 yr)	12 (2 yrs)	3 (3 yrs)	8 (1 yr)	6 (1 yr)
After	0 (1 yr)	0 (1 yr)	3 (2 yrs)	9 (3 yrs)	0 (1 yr)	1 (1 yr)

Number of Accidents (Time Period)

Figure 12. Data Required for Chi-Square Analysis (Flannery and Datta, 1996, p. 6)

The authors used a normal approximation test to prove that the before-and-after group data are neither correlated nor statistically independent. Since this test requires similar time periods for both before-and-after conditions, they used data from two years prior to the construction of the roundabout and data from one year after the roundabout installation (Flannery and Datta, 1996, p. 107). The authors found that $X^* = (8.93)$ and is $> X$. Thus, the “[r]eduction in the mean of crashes for before and after period of roundabout construction is significant at a 99% level of confidence” (Flannery and Datta, 1996, p. 108).

However, results from Isebrands (2009b) and Flannery and Datta (1996) should be used with caution. First, the number of crashes always fluctuates in a stochastic process (Daniels and Wets, 2005). Second, other general trends may influence the number of crashes, including policies, law, and changes in traffic volume. Third, the installation of roundabouts is sometimes the result of high crash rates that can have a regression-to-the-mean (RTM) affect that is not accounted for in a simple before-and-after study.

2.5.4.3 Empirical Observation (Conflict Studies). In Sweden, Hyden and Varhelyi (2000) used a before-and-after study to test the long-term effects of small roundabouts. They attempted to answer seven questions pertaining to roundabouts; do they: (1) reduce speed, (2) result in lowered risk of injury, (3) promote user interactions, (4) have no effect on redistribution of traffic, (5) increase time consumption when no give away regulation occurs or decrease time consumption with no signalization, (6) increase emissions when no give away regulation occurs and decrease emission with signalization, (7) have no change in noise level? Two of the above mentioned areas, rate of speed and risk of injury, are related to safety. Crash data was collected at the study locations six months after construction and was compared to crashes in the before period (1983-1990). The authors used conflict technique, i.e., relating conflicts to crashes. The severity of the conflict was based on time to accident (TA) and conflicting speed (CS).

Trained observers video recorded each of the 12 intersections for 30 hours. Additionally, the authors calculated the number of expected injury crashes per year by multiplying the ratio of serious conflicts and injury crashes depending on the type of road users involved. A behavioral study was also conducted to see the interactions among the roundabout users. Conflicts between multiple vehicles, bicycles and vehicles, and pedestrians and vehicles were examined. The results showed that serious conflicts between vehicles and vehicles increased while pedestrian-vehicle and bicycle-vehicle conflicts decreased. This before-and-after study is slightly biased because the intersections selected for this study were chosen because they had a high frequency of crashes prior to the construction of roundabouts.

2.5.4.4 Generalized Linear Models. Churchill et al., (2010) conducted both a cross-sectional study and a before-and-after study to understand the overall safety effect of roundabouts. Crash data from all roundabouts built in the Netherlands from 1999 to 2005 was analyzed. The authors were limited in terms of the total number of conventional intersections and the traffic volumes related to both conventional intersections and roundabouts. As a result, they examined the aggregate fatal crash data and found that while the number of fatalities at conventional intersections decreased, the number of fatalities at roundabouts increased. However, this may be due to the fact that the fatal crash frequency was not normalized (i.e., total number of roundabouts was not included in the analysis). The results may not represent actual conditions for either roundabouts or conventional intersections because the cross-sectional analysis in this study was found to be biased.

For the before-and-after study, data was obtained from the Dutch National roads database and the Dutch database of registered crashes. ArcGIS was used to geocode the data into a map. The researchers assumed a buffer of 40 meters around the roundabout for crashes. This procedure might induce some bias because the precise location of the intersections is unknown. A generalized linear model was built with the assumption that “the counts per crash year and per reconstruction year are linearly dependent on the number of locations retrofitted in that year” (Churchill et al., 2010, p. 38).

2.5.4.5 Odds-ratio and Meta-Analysis. Branbender, Nuyts, and Vereeck (2005) conducted another before-and-after study that included a comprehensive analysis of the safety of existing roundabouts to other controlled intersections. Using odds-ratio matching, the authors first made sure the comparison groups (intersections) had the same characteristics (i.e., speed limit) as the roundabouts. An odds-ratio matching is defined as “the ratio of the change in the number of crashes at the roundabout locations before implementation and the change in the number of crashes in the comparison group” (Branbender, Nuyts and Vereeck, 2005, p. 290). The odds-ratio for one year is compared to the previous year.

Since the number of crashes at a specific location fluctuates around an unknown average, the expected number of crashes at a roundabout, taking into account the reversion to mean (RTM) affect can be calculated using the expected number of crashes at the location where the roundabout was to be built, after correction for RTM effect, the average number of crashes per year for the comparison group, including the crashes at the location where the roundabout is implemented; (before the construction of the roundabout,

the location is considered comparable to the comparison group and could be included). Next the number of years is considered, the number of crashes in year t , at the location where roundabouts were constructed, and the weight given to the average number of crashes of the group (for the comparison group) are calculated. Then, the effectiveness ratio is calculated and finally, the overall safety effectiveness is defined as "*the weighted average of the results over the different years, where the weight assigned to the group of roundabouts is the inverse of the variance*" (Branbender, Nuyts and Vereeck, 2005, p. 292).

Similar to Branbender et al., (2005), Elvik (2003) performed the log-odds method of meta-analysis. The author estimated the safety effect for roundabout installation by comparing the number of crashes after the conversion to the number of crashes before, and then comparing this ratio to the ratio of the number of crashes after and before in a comparison group of intersections.

In this study, Elvik (2003) reviewed 28 studies that evaluated safety on roundabouts. The study also conducted traditional meta-analysis, where the data were grouped based on number of approach legs and crash severity to explore the source of variation. Additionally, meta-regression analysis was used to supplement the traditional meta-analysis.

Daniels et al., (2008) also used odds-ratio matching and meta-analysis to evaluate bicyclists' safety at roundabouts. Taking a sample of 91 roundabouts in Flanders, Belgium, and crash data from 1991 to 2001, they grouped the roundabouts around different speed limits, and their locations (i.e., inside or outside built-up areas). They also took the comparison group of other controlled intersections, 76 for inside built-up areas, and 96 intersections for outside built-up areas, and then prioritized the nearby intersections based on approach speeds.

Meta-analysis has two basic weaknesses. First, meta-analysis cannot improve the quality of the evaluation of the study (Elvik, 2003). For example, after evaluating different study designs, Elvik (2003), stated that the quality of simpler study designs might weaken the quality of more advanced studies. Another potential weakness of meta-analysis is that it can be biased. The bias may occur when previous studies' findings go against conventional wisdom so they are regarded as having little value. Therefore, this study adopts the trim-and-fill method to help convert the bias, which is defined as "a non-parametric method for diagnosing and correcting for publication bias, based on the assumption that a funnel plot of results should be symmetric around the mean in the absence of publication bias." (Elvik, 2003, p. 5)

2.5.4.6 ESE Process. Turner and Brown (2013) used the ESE process to assess the safety improvements of roundabouts. "The three key elements of the ESE (or EASY) process are: 1. estimation of expected crashes using the best available base (crash) model; 2. safety observation based on experience; and 3. evidence from national and international road safety research. To give confidence in the results, the ESE process includes checking throughout the process by reviewing and comparing with other available information sources." (Turner and Brown, 2013, p. 2).

2.5.4.7 Empirical Based Before-and-After Studies. According to Persaud et al., (2001), a simple before-and-after study may be biased due to the RTM effect because roundabouts are usually constructed when an intersection has safety problems. Consequently, if the study fails to control this effect, the study is likely to overestimate the safety effect of the roundabout conversion. To respond to the need to address the RTM effect, Persaud et al., (2001) employed the empirical Bayes before-and-after procedure. Retting et al., (2001) and Rodegerdts et al., (2007) also use this procedure.

Rodegerdts (2007) evaluated 310 roundabouts in the United States with different characteristics, such as urban-suburban-rural setting, number of legs, number of circulating lanes, previous intersection type, age of roundabout, and geographic locations. The authors analyzed 90 roundabouts based on data availability, geometric information and entering daily traffic volumes. Roundabout-level crash prediction models as a

function of number of lanes, number of approach legs, and AADT were developed. Similarly, approach-level crash prediction models related common types of crashes to AADT, including key geometric factors.

2.5.5 Roundabouts and Safety: Conclusion

This section reviewed the existing literature on roundabouts and safety. Many studies showed that roundabouts have increased safety performance, with safety effects ranging between 17 to 70% for crash reductions. However, these results could not be fully taken as the effect of roundabout conversion because there are other contexts and issues, such as the argument that conversions from FWSC intersections to the modern roundabouts do not significantly reduce the total and injury crash rates (Rodegerdts, 2007). As a consequence, how the retrofitted processes and location selections were made may influence the safety effect calculation. Furthermore, the literature review found numerous concerns from researchers about the effect of retrofitted roundabouts for various users and modes. Safety performances of roundabouts may be reduced for vulnerable users such as bicyclists, pedestrians, people who are visually-impaired or with disabilities, and elderly road users. The concern is also highlighted for big trucks that require special treatments and design on the roundabout. Many methods are available for performing safety analysis: descriptive analysis, chi-square statistics, empirical observation, generalized linear model, odds-ratio and meta-analysis, ESE process, and empirical before-after study.

2.6 Evaluation of Gaps in Roundabout Literature

An evaluation of existing literature on roundabouts, access management, safety, and capacity showed several gaps in knowledge. Gaps are identified based upon available literature regarding the use of roundabouts, particularly as they apply to access, operations and roadway capacity, and safety.

2.6.1 Literature Gaps in Access Management

Based on the literature review on access management, major gaps in the literature were identified. Little literature exists about access management as it specifically applies to roundabouts. As was described earlier in this chapter, many studies have been completed about the use of access management strategies at intersection types (stop-controlled, signalized intersections, un-signalized intersections) as they relate to various design and planning element considerations. However, few such studies have been completed related to roundabouts and access management.

2.6.2 Literature Gaps in Roundabout Operations and Capacity

Based on the review of literature on roundabout operations and capacity, several gaps in the literature were identified:

- The analytical approach seems to be the most common methodology in roundabout capacity analysis; there is a lack of studies that use statistical approaches. It is more difficult to use statistical approaches because there are fewer roundabouts that reach capacity. The analytical approach does not have that requirement; it is based on gap acceptance.
 - The analytical approach needs to incorporate the calibration of driver behavior to match specific local conditions.
 - A more streamlined process of collecting the data from local roundabouts could also be considered to standardize the data collection process.
- Only a few studies focus on the impact of bicycles and pedestrians on roundabout capacity.
 - For studies specifically related to access management, more information is needed examining how slow traffic influences roundabout capacity models, particularly as related to driver behavior.
 - However, this information would be difficult to acquire, since each roundabout has unique geometric and pedestrian crossing designs.
 - There is currently not a reliable simulation tool for pedestrian movement at roundabouts.
- Studies on unbalanced traffic at roundabout entries have incomplete data.
 - Since access management is the primary goal of this research project, unbalanced traffic issues should be addressed with care, since existing studies show unbalanced traffic could have a great impact on roundabout performance and can indirectly affect access to businesses near roundabouts. However, the degree of the impact is not yet clear.
- Although some studies consider the impact of heavy vehicles on roundabout capacity, this impact is heavily dependent on local conditions, especially the geometric design of the roundabouts.
 - The use of a standardized design guide relating vehicle characteristics to roundabout geometric design would present reliable standards for engineers to design roundabouts.
- Overall, there are few studies exploring the impacts of roundabouts on corridors. Existing literature suggests that roundabouts do not perform significantly better than signalized intersections in a corridor. Roundabouts seemed to have higher performance when the corridor has irregular intersection spacing (Kittelson and Associates, Inc. 2013). But whether a corridor of roundabouts is superior to other types of intersections really depends on site-specific operational conditions

(Kittelson and Associates, Inc. 2013). Of even more interest to our research, would be studies along corridors with unbalanced traffic conditions, or high levels of pedestrian or bicycle traffic, and a before-and-after study of the conversion from signalized intersections into a corridor of roundabouts.

2.6.3 Literature Gaps in Roundabout Safety

There is substantial agreement in the literature reviewed that modern roundabouts have significant safety impacts when compared to traditional traffic intersection treatments. While these safety improvements have been observed and studied internationally using several different methods, gaps in this research still exist. Based on the review of literature on roundabout safety, several general gaps in the literature were identified:

- Longitudinal safety studies generally include less than two years of data.
 - Studies should be made over periods longer than two years, because then the safety effects can be more clearly identified.
 - In the first two years of implementation or adaptation period, users are still learning the rules and guidelines.
- Collectively the longitudinal safety studies lack location variation. Roundabouts in a greater diversity of contexts need to be analyzed in longitudinal studies.
- In some studies, the location of modern roundabouts seems to have been chosen because those intersections have high crash frequencies. This selection bias weakens the conclusions because it can be difficult to know if the improvements are due to the unsafe conditions before the conversion to a roundabout, changes in driver behavior due to the conversion to a roundabout (i.e., the treatment effect) or whether the lack of improvement is due to the difficulty of designing a solution in a high-crash location.
 - Studies should incorporate different locations with different characteristics.
- Most studies used small sample sizes.
 - Studies should use larger sample sizes, to give additional statistical significance and accuracy.
- Simple methods of before-and-after studies do not compare the effectiveness of modern roundabouts to other intersections without roundabouts. In other words, more carefully designed control studies need to be developed.
- Two methods that acknowledge both before-after and cross sectional conditions are odd-ratio and empirical Bayes. These methods have been deployed in different contexts, which may limit their generalizability to other contexts.
 - The odd-ratio method was used by Branbender et al., (2005), Daniels et al., (2008), and Elvik (2003) in studies that took place in Europe.
 - The empirical Bayes method was used by Persaud et al., (2001), Retting, et al., (2001), and Rodegerdts et al., (2007) in the analysis of roundabouts in the United States.
 - Both methods used the meta-analysis to enable the groups of contexts: for example, suburban and urban, the number of legs, and traffic flow. However, the latter method incorporates the characteristics of modern roundabouts or other controlled-intersections in the prediction model. In other words, empirical Bayes gives a more complete picture of the variables that influence the crash rate.
- Rodegerdts et al., (2007) is the most comprehensive study using the largest number of roundabout in the sample (310 roundabouts). However, the evaluation of safety for a group of locations that share similar users' characteristics, roundabout design, and driver behavior, for example in one state, may be important to enhance the knowledge of the safety of roundabouts.
- Some of the literature proposes additional different geometries on the roundabouts; additional study to accommodate the needs of other users is another gap in knowledge. Although the result of

the geometry is promising, it may affect other groups of users that might find more challenging conditions in crossing the roundabouts.

- Specifically in Florida, the Clearwater Beach roundabout has been evaluated intensively to understand pedestrian safety (Rodegerdts et al., 2007). Although this location may be a good location to understand pedestrian behavior and safety, it is not necessarily representative of roundabout locations. Additional research is necessary to determine how representative this location is of the pedestrian conditions at roundabouts.

Based on the review of literature on roundabout pedestrian safety, several gaps in the literature are identified:

- Studies on the effectiveness of modern roundabouts in the United States examine very few locations, and those same locations are examined repeatedly. As such, a greater number of sample locations should be incorporated into roundabout research, and a greater diversity of both pedestrian, bicyclist and large vehicle conditions should be incorporated into this analysis.
- Crash reports and the potential for location bias by disabled pedestrians force studies to rely upon observational research in the United States. Observational research should be further incorporated with statistical research at locations with high numbers of pedestrians or bicyclists.
- Although perceived risk and actual risk may lead to different consequences in the modern roundabout development, knowledge about perceived risk for each group of vulnerable users is important for enhancing the balance of users' needs.
- Understanding the perceptions of vulnerable users may help designers of the modern roundabout address the needs of those users.
- Treatment of vulnerable users, including bicyclists and pedestrians, is inconsistent throughout the different states. National transportation organizations should provide general guidelines regarding how to incorporate all users' needs, especially vulnerable users.

Based on the review of literature on roundabout design and safety measures, several gaps in the literature were identified:

- Arndt and Troutbeck (1998) show the importance of understanding driver behavior, traffic conditions, and roundabout geometry in one specific location, and they compare Australia and the United Kingdom. Consequently, this implies that those conditions are different in the United States. The enhancement of previous models available to be applied in the United States or other specific locations may be the gap of knowledge.
- Even though it is acknowledged that multi-lane roundabouts are less safe than single-lane roundabouts, multi-lane roundabouts need additional attention because they are often used for capacity reasons. Additional research should explore the effects of multi-lane and complex roundabouts on both safety and capacity.
- Although these studies show several design-related influences on safety levels, the roundabout design should balance other factors, such as, capacity and construction cost. Optimum balances between safety, capacity, access, and cost should be further explored.

Chapter Three: Methodology

This research used multiple methods to understand the state of practice in roundabouts and access management in the state of Florida. They include a review of state access management and roundabout guides, the collection and analysis of crash information at all roundabouts in the state, and the selection of a sampling of roundabouts in the state and the collection of and analysis of the field operations of these sites. In addition, a review and analysis of Florida-specific software to analyze the capacity and operations of roundabouts within the state will be conducted. As described in the Literature Review, the analysis of this information for Florida is complicated by the lack of previous research that specifically addresses access management near roundabouts and the absence of standard methods of providing guidance on access management and roundabouts by state departments of transportation.

3.1 Access Management and Roundabout Guides' Selection.

The review of national and state guidance was completed by reviewing two types of guidance: access management guides and roundabout guides. Several sources of national guidance on access management were identified. Documents that contain access management elements were found in the following types of documents: roadway or highway design/manuals; access management manuals; and driveway manuals. NCHRP Synthesis 404, *State of Practice in Highway Access Management* (Gluck and Lorenz, 2010) is particularly useful for this research because it includes data on where to find information on access management for each state; the information in that report is updated with a review of state department of transportation websites. Twenty-one DOTs include access management information on their website. Table 4 summarizes the various types of documents that state DOTs use as a part of their access management program. Most webpages contain information about the introduction of access management, the aspects that should be considered in analyzing access needs of new development, and links to design manuals and other related documents used by DOT staff. Forty-three states have incorporated access and/or access management on their planning and design policies. More specifically, nineteen states have access management manuals, separate from general design manuals. Eleven state DOTs mention access management on design manuals; while sixteen other DOTs have additional documents with various names. The complete list and links to DOT websites can be found in Appendix B.

Table 4. Main Documents on Access Management – Related State DOT Guidebooks

Access Management Manual/Guidebook	Roadway/Highway Design Manual	Other Related Documents
Alabama (2013)	Arizona (2012)	State Highway Access Code/Manual:
Florida (2009)	California (2012)	Colorado (1998)
Idaho (2001)	Connecticut (2012)	Delaware (2011)
Indiana (2009)	Illinois (2010)	District of Columbia (2010)
Iowa (2012)	Massachusetts (2006)	Maryland (2004)
Kansas (2013)	Montana (2007)	Wyoming (2005)
Michigan (2001)	New York (2002)	Driveway Manual or/and Encroachment Control:
Minnesota (2008)	Utah (2007);	Georgia (2009)
Mississippi (2012)	North Dakota (2009)	West Virginia (2004)
Missouri (2003)	South Dakota (web, 2013)	Access Connection Policy/Rules:
Nevada (1999)	Washington (2012)	Louisiana (2012)
New Jersey (2013)		Maine (2005)
New Mexico (2001)		Access Control Policy:
Ohio (2001)		Nebraska (2006)
Oregon (2012)		Washington (2009)
South Carolina (2008)		Wisconsin (FDM, 2011)
Texas (2011)		Right of Way Manual:
Vermont (1999)		Utah (2006)
Virginia (2007)		Montana (2007)
		Driveway Permit/Access :
		New Hampshire (2000)
		North Carolina (2003)

Source: DOT websites

The review of manuals and guidebooks for this research is similar to that completed in NCHRP Synthesis 404 *State of Practice in Highway Access Management* (Gluck and Lorenz, 2010), but this research reviewed a greater variety of access management documents; as such, it updates that report. Of the forty-three states and the District of Columbia with access management-related documents, sixteen states and the District of Columbia updated their guidelines after 2009. As a highlight, *the NCHRP Synthesis 404 - State of Practice* conducted surveys for all fifty states and obtained comprehensive information about access management program elements being developed by state DOTs, such as guidelines, general department policies, and driveway permit manuals, and standards.

Furthermore, this review specifies the access management techniques and geometric design elements that have been adopted by many states. Once the state guidance documents were identified, the analysis uses the sixteen categories of typical access management techniques that are used in the *NCHRP Synthesis 404: State of Practice* analysis (Gluck and Lorenz, 2010, p. 49-50):

1. Installation of the medians
2. Spacing for median openings/breaks
3. Spacing for un-signalized public street intersections
4. Spacing for un-signalized private driveways
5. Spacing for traffic signals
6. Prohibition of certain turning movements,
7. Corner clearance, and
8. Spacing for cross-street in the vicinity of interchanges
9. Setback and ISD
10. Geometric design standards for driveways

11. Provisions for right-turn and left-turn lanes
12. Purchase of access rights
13. Internal connection of parking lots between adjacent parcels
14. Subdivision restrictions for large parcels
15. Requirements for traffic impact studies
16. Requirement for traffic impact fees

Among these techniques, the synthesis reported that 80% of the states applied the first ten access management techniques and requirements for traffic impact studies of techniques (number 15). The purchase of access rights (number 12), was used by 66% of state DOTs. Internal connection of parking lots between adjacent parcels (number 13) and subdivision restrictions for large parcels (number 14) are used by 48% and 30% respectively of state DOTs, and only 16% of state DOTs have incorporated traffic impact fees (number 16). A summary of the use of the access management elements and techniques by the states can be found on Appendix C.

National guidance on roundabouts, access management, safety, and capacity, supplemented by a handful of states, who are leading the way in providing statewide roundabout guidance. Those DOTs included roundabout guidance in various types of documents. For example, some states include roundabout design standards in the roadway manual. Some states provide specific links to information about roundabout design. The Virginia DOT (VDOT) places the roundabout design information in the access management design standards; this is the only state that directly provides this information in a single place. Overall, 26 states have various levels of information about roundabouts on their websites. Most state DOT websites contain information for drivers about how to use a roundabout. Some states also link to the roundabout website of other states and the national guidance. Once the roundabout information for the 26 states and the District of Columbia were reviewed, 16 states that refer to access management in the context of roundabouts in their guidebooks were selected for further examination on roundabouts: Arizona, Florida, Kansas, Indiana, Iowa, Kentucky, Maryland, Michigan, Minnesota, New Hampshire, Pennsylvania, California, Washington, and Wisconsin. See Table 5 for information on the location of state information on roundabouts.

Table 5. The Sources of Roundabout States' Design Guidebooks

Roundabout Guide Document	Facility Development Manual	Access Management Design Standard	Roadway or Highway Design Manual
Florida (1996, 2000, 2012)	Wisconsin (2011)	Virginia (2007)	New Hampshire (2007)
Arizona* (2003)			Iowa (2009)
Kansas (2003)			Minnesota (2009)
Pennsylvania (2007)			Kentucky (2010)
California (2007)			Maryland (2011)
Iowa (2008)			Washington (2011)
Michigan (2011)			Arizona (2012)
Maryland (2012)			

* - cannot be accessed online

3.2 Site Identification

The first step in both the operational analysis and safety analysis was the identification of the location of all roundabouts in the state of Florida. The FDOT's RCI database includes an element called "ROTARY," which includes the following three codes: roundabout, traffic circle and mini-roundabout. A total of 219 roadway segments coded as "roundabout" were identified from the 2011 RCI database. Only four of those roundabouts were located on the on-system (i.e., state) roads, while the remaining 215 were located on the

off-system roads. Since the RCI database does not include all the off-system roads, an extra effort was made using Google Earth to visually identify additional roundabouts on the off-system roads that are not covered in the RCI database. This netted an additional 64 locations, for a total of 283 roundabouts for this study.

For operational analysis, 226 roundabouts in the State of Florida were analyzed by viewing the map using Google Map, and finally 13 sites were selected for a detailed analysis. The summary of the 226 sites are outlined in the following table.

Table 6. Summary of Roundabouts in Florida by Design and Context

Category	Aspects	Number of Roundabouts
Number of legs	Two	3
	Three	85
	Four	122
	Five +	16
Number of circulating lanes	Single lane	164
	Multi-lane	53
	Turbo/Spiral	9
Location of Driveway	At approach lane	24
	At egress lane	33
	Driveway directly link to roundabout	10
	More than one driveway	128
	No driveway	31
Surrounding land use	Residential	100
	Commercial	63
	Mixed-use	54
	Other	9

3.3 Safety Analysis

This section describes the methodology used to conduct safety analysis. It includes how the roundabout locations in Florida are categorized, how crash data including both crash records and police reports for the locations identified were extracted, how crash locations to improve data quality were corrected, and how police reports for in-depth safety analysis were reviewed.

3.3.1 Categorize Roundabout Locations

After the 283 roundabouts in the state were identified, additional information such as land use (i.e., commercial or residential), roundabout type (i.e., single or multi-lane), presence of other roundabouts in the vicinity, number of approach legs, number of commercial and residential driveways, presence and type of median, presence of on-street parking, presence of bike lanes and pedestrian crosswalks on roundabout approach legs was collected. For safety analysis, roundabouts were classified as either commercial or residential. Commercial roundabouts are those that are located in commercial areas that serve mostly commercial traffic. Locations with a mix of land uses, including both commercial and residential, are re-classified as commercial. Residential roundabouts are those that are located in mostly residential areas. Figure 13 gives an example of each of two land use types, respectively.



(a) Commercial Land Use

(Location: Pier Park Drive., Panama City Beach)

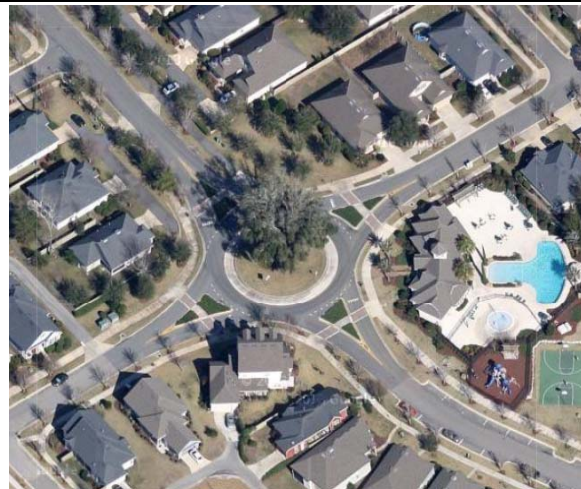

(b) Residential Land Use

(Location: SW 77 Avenue., Alachua)

Figure 13. Examples of Roundabouts Located in Each Land Use Type**3.3.2 Extract Crash Data**

Five years of crash data from 2007-2011 were used in this analysis. Crashes that occurred in the vicinity of the roundabouts were spatially identified in ArcGIS 10.0. The locations of the 219 roundabouts identified using the RCI database were imported into ArcGIS using their roadway IDs and begin and end mile posts. The remaining 64 roundabouts that were visually identified were imported into ArcGIS using their latitude and longitude coordinates obtained from Google Earth.

Shape files of the crash data for the years 2007-2011 were downloaded from the FDOT Unified Basemap Repository (UBR) for both on-system and off-system roads. These files were separately imported into ArcGIS. A 500 ft. buffer was then created around each of the 283 roundabouts. All the crashes that occurred within the 500 ft. buffer were spatially identified. An influence area of 500 ft. was chosen to include all the crashes that could have been potentially affected by the presence of roundabouts. A total of 2,941 crashes were found to have occurred within 500 ft. of the roundabouts. Police reports of all these crashes were downloaded from the Hummingbird web system hosted on FDOT's Intranet.

3.3.3 Correct Crash Locations and Review Police Reports

An existing in-house web-based tool was adapted for this study to facilitate the process of reviewing the police reports. The tool has the capability to visually display crashes by crash type and crash severity, as shown in Figure 14 and Figure 15, respectively. The tool helps to quickly navigate from one police report to the next by either clicking the "Next" and "Previous" buttons, or by clicking on the crash icon in the aerial map. The tool also has the capability to move from one roundabout location to the next, and to navigate to a specific roundabout based on roadway name.

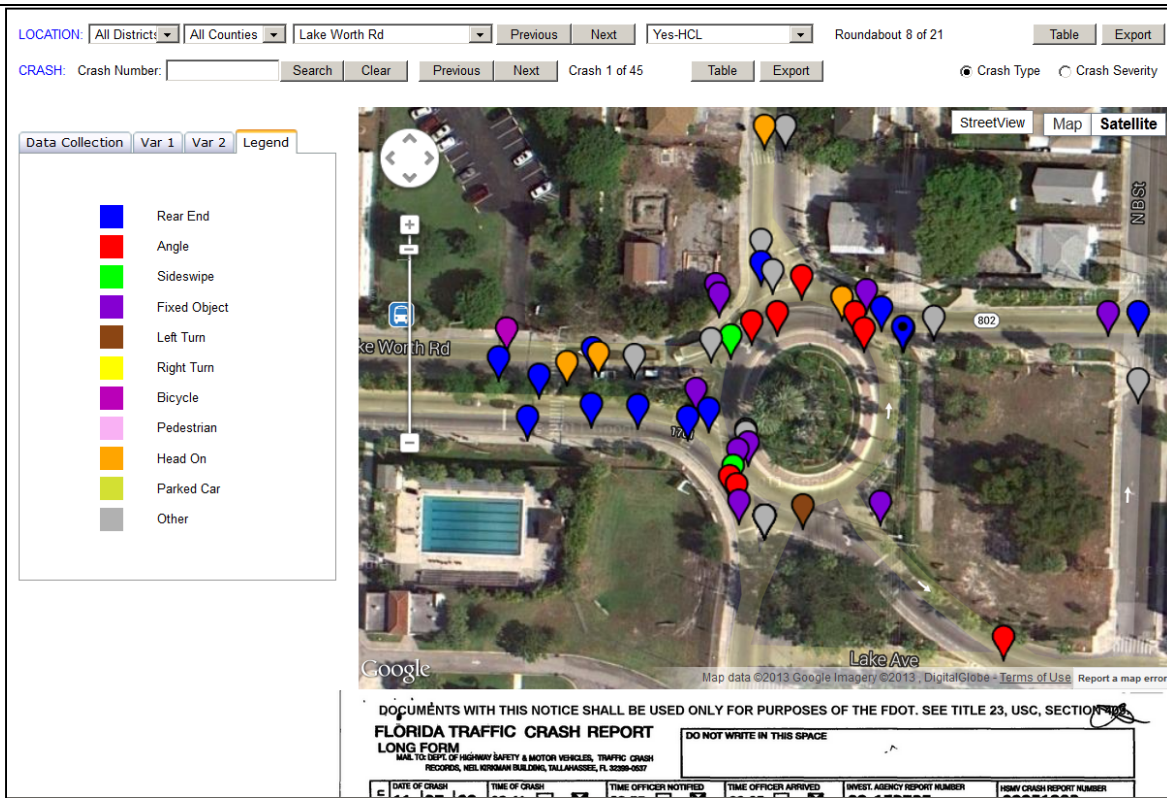

Figure 14. Crashes Displayed by Crash Type at a Roundabout

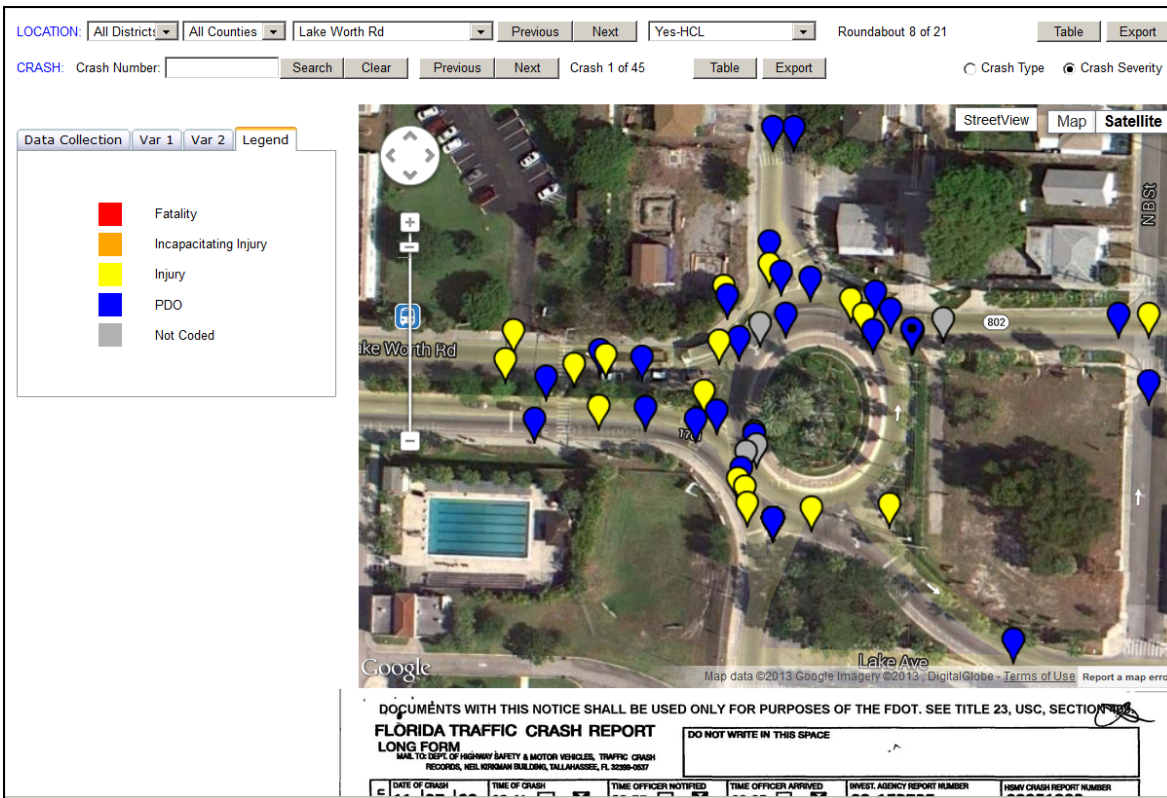

Figure 15. Crashes Displayed by Crash Severity at a Roundabout

A few roundabouts did not exist for the entire study period as they were constructed after 2006; however, the exact construction period was unknown. Based on the illustrative sketches in the police reports, crashes that occurred at the study locations prior to the construction of the roundabouts were excluded from the analysis.

Since the analysis focuses on evaluating the influence of access features such as driveways, median openings, etc., on the safety performance of roundabouts, accurate crash locations are crucial. A quick review of the police reports revealed that the crash locations are approximate, and in some cases, the locations are off by several hundred ft. To address this issue, crash locations of all 2,941 crashes were manually verified. Locations of 1,191 crashes (40.5%) were found to be incorrect and were updated. For each crash, the crash location was verified and updated using the following steps:

1. Identify the roundabout location on Google Earth.
2. Review police report(s) of the crash to pinpoint the actual location where the crash occurred. This step might require reviewing both the crash diagram and the description from the police reports.
3. Obtain latitude and longitude coordinates of the correct crash location from Google Earth.
4. Record the correct coordinates in the web-based tool.

Once the locations of all crashes were verified and recorded, the crash file in the web-based tool was updated based on the new coordinates. Next, all the crashes that did not occur on the roundabout or on an approach leg leading to a roundabout were excluded from further analysis. For example, Figure 16 shows a crash that occurred within 500 ft. from the roundabout, but did not occur on the roundabout and its approach legs. A total of 1,059 crashes were not found to be directly related to the roundabouts and were removed. This resulted in a total of 1,882 crashes that were included in the detailed analysis.

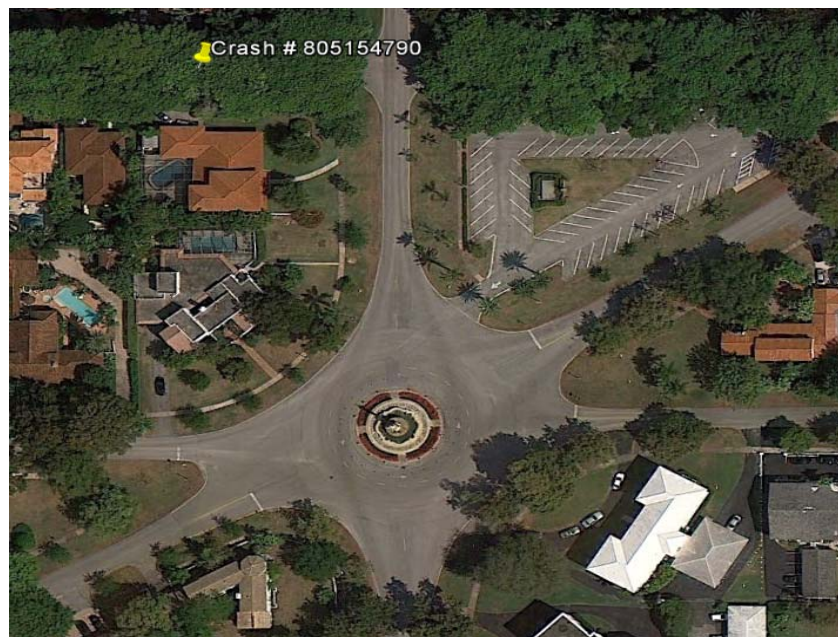

Figure 16. An Example of a Crash That Was Not Directly Related to the Roundabout

For the preliminary safety analysis, potential safety issues pertaining to roundabouts and access features were first identified from the literature review. Accordingly, the safety analysis focused on the following four potential safety areas associated with roundabouts:

1. Impact of driveway corner clearances on roundabout safety.
2. Safety impact of median openings in the vicinity of roundabouts.
3. Safety at roundabouts that provide direct access to activity centers.
4. Safety of vulnerable road users including pedestrians and bicyclists.

Once the crash locations were corrected, the illustrative sketches and descriptions in the police reports were reviewed in detail to categorize crashes into the aforementioned categories for detailed analysis. The web-based tool was customized to facilitate this process. Figure 17 gives the screenshot of the tool's interface used for data collection. In addition, data from the police reports were used to obtain crash severity using the following codes:

- K – Fatal Injury
- A – Incapacitating Injury
- B – Non-Incapacitating Injury
- C – Possible Injury
- O – Property Damage Only

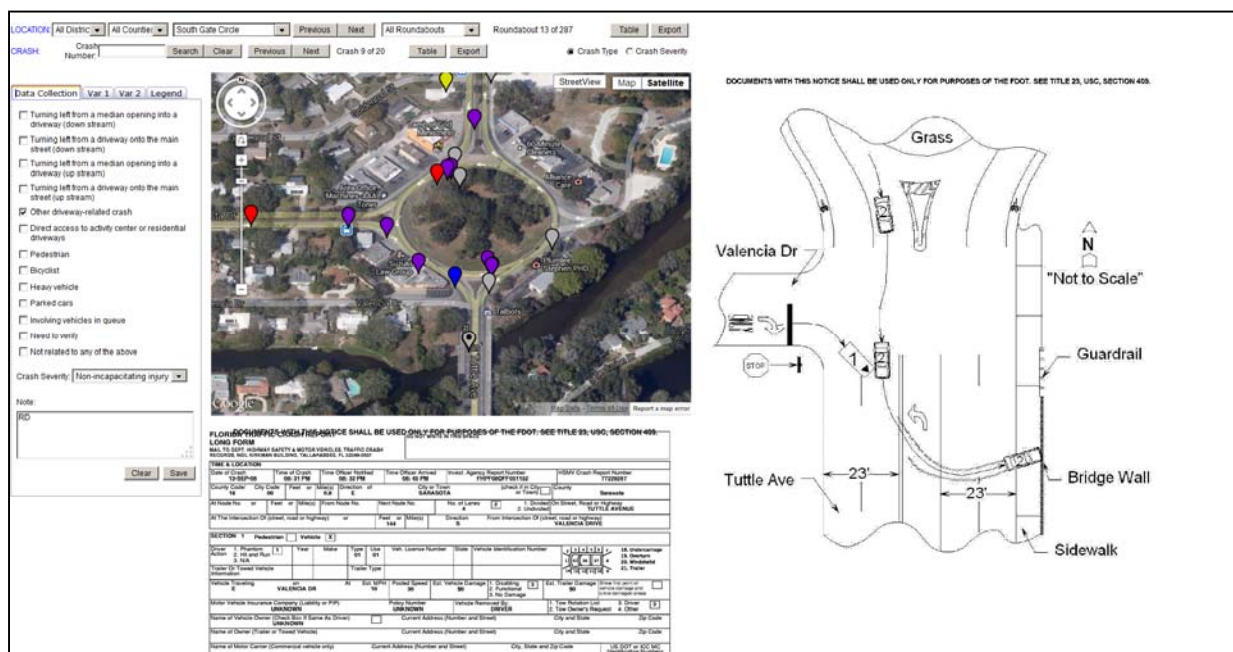

Figure 17. Data Collection using Web-based Tool

3.4 Operational Analysis

The purpose of the operational analysis is to evaluate the performance of roundabouts and identify the potential issues related to access management. This section explains the method for selection of study sites, the collection of data on roundabout operations (video and site observations), and the analysis of the data collected at each of the sites. An evaluation of FDOT-utilized software is also included to assess the suitability of these software packages on analyzing roundabout and access management issues.

3.4.1 Data Collection Site Selection

Using Google Earth, we visually inspected each of the 283 roundabouts to understand the design, regional context, and access characteristics of each roundabout using the categories shown in Table 7.

Table 7. Criteria for Selecting Roundabouts for Operational Analysis

Category	Aspect	Definition
Design of roundabout	Type—number of legs	Number of approaching legs: A range from 3 to 6 legs
	Type—number of lanes	Number of circulating lanes: Single lane; Multilane; Complex Roundabout (Spiral, turbo)
	Geometric consideration	The geometric characteristics of the roundabout includes: Medians on approaching lane; Slip Lanes; Stub-out.
Regional context	Regional location context	Relative location to nearest town
	Whether in urban area	Urban, suburban, rural
	Transportation context	Whether or not on a state highway; Within 1 mile of interstate; Near state highway; No highway nearby.
Access	Driveway placement	In the middle of roundabout; On the access approach of roundabout; On the egress approach of roundabout; On both access and egress approach of roundabout; No driveway nearby.
	Land use type around roundabout	Residential single-family housing; Residential multi-family housing; Commercial; Mixed-use.

Once all sites were evaluated, a smaller set of sites were selected for the operational analysis based on the following criteria: (1) modern roundabout with splitter island; (2) located in an urban area with significant amount of traffic; (3) have potential for access management issues, e.g., adjacent driveway and intersection nearby; (4) either one lane or multi-lane; and (4) could have on-street parking or be a part of a series of roundabouts.

For the operational analysis, the roundabout list was narrowed down in three stages. First, 100 sites were selected from the entire list by merely looking at roundabout geometric design features and the land use context around the roundabout. Then, several teammates further narrowed the number down to thirty-four based on more stringent criteria, such as selecting sites with larger traffic volume. After that, each researcher in the team voted for ten sites, and the highest ranked eighteen sites were chosen for actual visits through a review process that involved internal team meetings, discussions, and a site selection meeting in the state of Florida with the FDOT Project Team. Finally, the eighteen sites were visited, from which thirteen sites were considered suitable for data collection based on the traffic volume and geometric design of the sites. The five sites that were initially selected, but for which we did not collect data, were eliminated because there is no driveway in close proximity to the roundabout, or they are located in a low-density area where there is not enough traffic to create significant delay and queuing near the roundabout.

Among the thirteen selected sites, only one is located on a state highway. Table 8 shows the summary of roundabout selection process. Video was collected from those thirteen sites. Figure 18 shows the locations of both selected roundabouts and the pool of roundabouts. Details about the thirteen selected sites are included in Appendix D.

Table 8. Summary of Roundabout Selection Process

Steps in Selection	Number
All Roundabouts	283
Considering Context of Roundabouts (e.g., geometric design, land use context)	100
Detailed Analysis by project team (e.g., location of driveways, level of traffic)	34
Ranking by each team member and review by project managers	18
Site observation - data collection	13

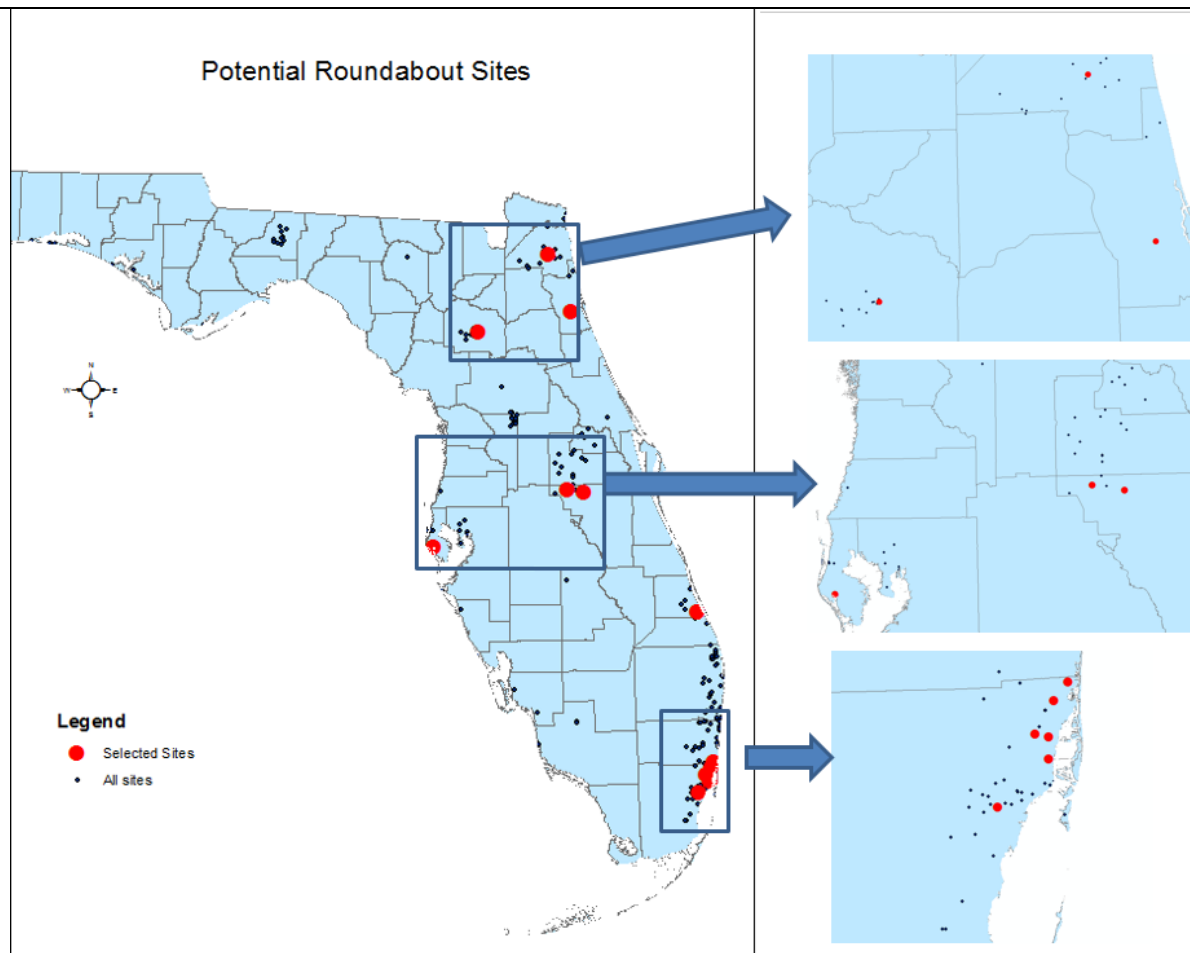

Figure 18. Roundabout sites in Florida Selected for Operational Analysis

3.4.2 Data Collection

In addition to the context data collected as a part of the selection process, the operational analysis of roundabouts required the collection of field data on vehicle turning movements, conflicts, and violations. During the data collection, two techniques were used to gather information required for operational analysis: site observation of the flow of traffic near the roundabout, and video recording of the entire intersection followed by manual extraction of video clips with access management issues. Table 9 summarizes the features and time of data collection for the selected sites.

Table 9. Summary of Features and Survey Time of Selected Roundabouts of Thirteen Roundabouts and Data Collection Times for Operational Analysis

County	Site Name	Data Collection Date and Time	Number of Circulating Lanes	Number of Legs	Presence of Driveway
Alachua	SW 2 nd Ave. and SW 6 th St.	4/5/13: 3:00 pm – 5:30 pm	1	4	On both access and egress approaches
Broward	Margate Blvd. and NW 58 th Ave	5/23/13: 7:40 am – 9:40 am	Spiral	4	On both access and egress approaches
	Holmberg Rd. & Parkside Dr.	5/16/13: 3:25 pm – 5:30 pm	1	3	On both access and egress approaches
Duval	Independent Dr. and S. Laura St.	4/23/13: 11:00 am – 2:00 pm	1	3	On both access and egress approaches
Miami-Dade	Biltmore Way and Sagonia St.	5/15/13: 4:50 pm – 7:15 pm	Spiral	4	On both access and egress approaches
	Greenway Dr. and Sagovia St.	5/14/13: 4:50 pm – 7:10 pm	1	5	On both access and egress approaches
	NE 10th Ct. & SW 152 nd Ave.	5/13/13: 5 pm – 7:20 pm	1	4	On both access and egress approaches
	Ponce De Leon Blvd. and Ruiz Ave.	5/21/13: 4:50 pm – 7:05 pm	Spiral	5	On both access and egress approaches
Orange	Eagle's Reserve Blvd. and Dyer Blvd.	4/14/13: 12:00 pm – 1:00 pm	2	4	On the access approach
Osceola	MLK Blvd. and N. Central Ave.	4/5/13: 11:00 am – 12:00 pm	Spiral	4	On the egress approach
Pinellas	Causeway Blvd. and Mandalay Ave.	3/22/13: 3:00 pm – 5:30 pm	2	6	In the middle of roundabout
St. Johns	CR-210 and Mickler Rd.	5/9/13: 1:00 pm – 3:00 pm	1	4	In the middle of roundabout
St. Lucie	CR-707 and Ave A	5/9/13: 1:00 pm – 3:00 pm	1	4	On both access and egress approaches

During the site visits, five activities took place. First, we verified the geometric conditions in the roundabout diagrams. Next, we reviewed the traffic operations approaching and exiting the roundabout by collecting two to four hours of video data at the peak operating time of each site. Information was collected on land uses associated with adjacent driveways and on traffic volume at the location of access points during the site visit.

Traffic movement was videotaped at all 13 selected sites, and useful video clips with access management issues were extracted for the operational analysis. The cameras for the data collection at each roundabout were placed based on the geometric design and driveway locations of each roundabout. Figure 19 shows an example of the camera location for field data collection. Under some circumstances, as shown by Camera 1

in Figure 19, in order to record driveway movement on each site cameras were put further away from the roundabout to capture the interaction between a driveway and the approaching lane. Cameras 2 and 3 are placed in order to record the pedestrian flow and vehicle conflicts on the other two approach legs of the roundabout.

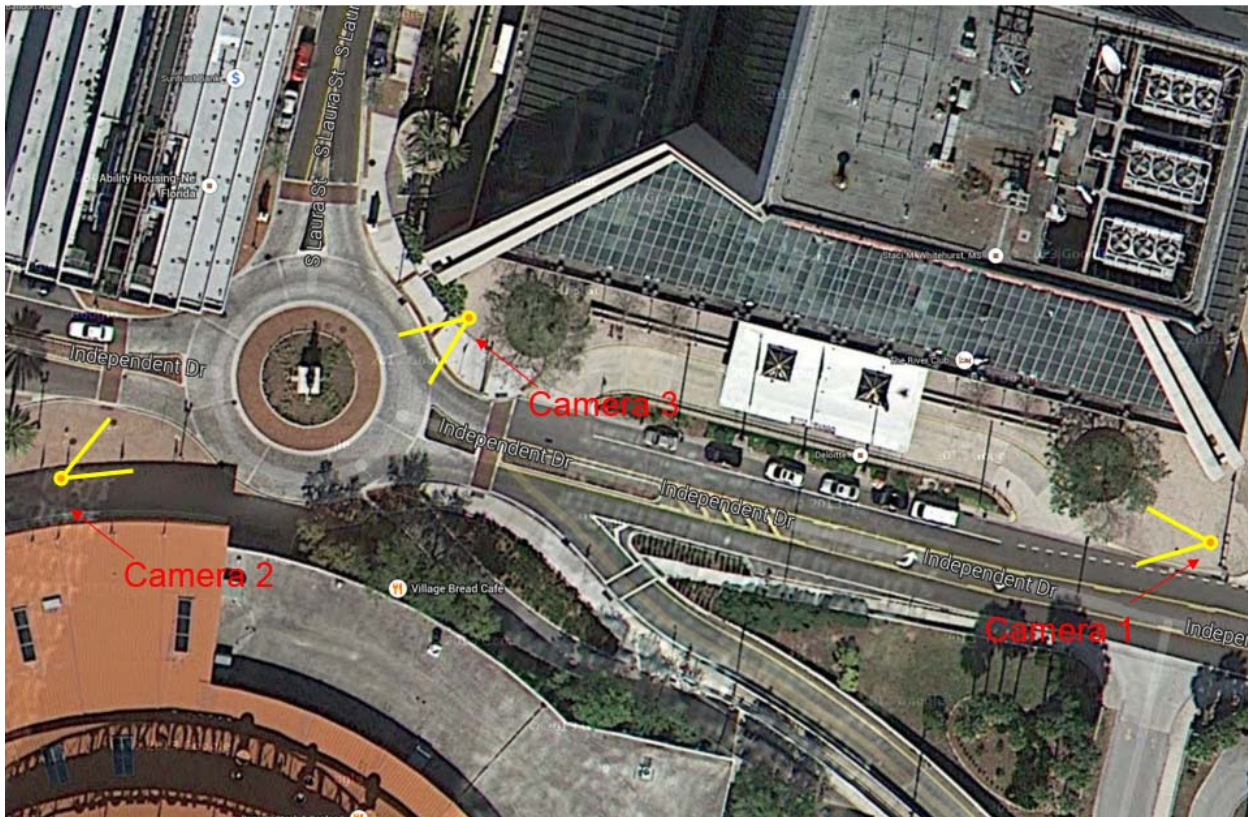

Figure 19. Camera Location of Video Recording for Independent Drive and South Laura Street in Jacksonville

In order to collect enough information, data collection took place during the busiest hours of operation (peak hours) at each roundabout. For example, if a roundabout is located on a major arterial section, data were collected during the usual peak hour. For roundabouts located near shopping centers, data were collected slightly later than the peak hour or on weekends.

3.4.3 Data Analysis

The operational analysis aimed at finding access issues related to roundabouts. More specifically, in the data analysis, we considered the conflict points at the intersection of driveways and the approaching lane of the roundabouts, the impact of the queue on the operation of nearby stop-controlled driveways, the conflicts between vehicles and other roadway users, e.g., bicyclists and pedestrians, and the impact of driving violations on the operations with the roundabouts, e.g., pick up and drop off in active driving lanes. This analysis includes the impact of median openings at the approaching lane on the operation of the entire roundabout, and the queuing associated with a driveway that is located near a roundabout which may disrupt the operation of either the driveway or the roundabout. The videos collected during the site visits were carefully reviewed to identify the types of access issues.

3.4.4 Assessment of FDOT Software for Roundabout Evaluation

Software packages used by the FDOT were evaluated to understand their capability to analyze roundabout operations and capacity and, in particular, to address, issues related to access management. Both deterministic software and simulation packages were evaluated. Software packages currently used by FDOT, including HCS 2010, SYNCRO, and CORSIM, are compared with other software packages to understand the suitability of these tools to evaluate access issues.

Examples of analysis of roundabouts capacity, delay and queue, are given in the analysis in order to evaluate its effectiveness in assessing roundabout operations. Where these tools may be deficient, recommendations are made on how to improve them to make them more effective for the evaluation of roundabouts and access management.

Chapter Four: Review of National and State Practices

This chapter is organized into six sections. First, the national and state guidebooks for access management and roundabouts are reviewed. Second, Florida's guidebooks are summarized. Third, national and state guidebooks that have taken access management into consideration in the context of roundabouts are presented. Then, roundabout location consideration guidelines and geometric design from the national and state guidebooks are briefly mentioned. Next, the findings of safety and operational analysis of roundabouts are presented. Access management issues are discussed with consideration of safety and operational aspects of roundabouts. This chapter also includes a detailed discussion of the limitations of Florida's roundabout guidebooks.

4.1 National and State Guidebooks for Roundabouts and Access Management

To understand the state's role in roundabout design and access management, we identified existing roundabout policies and guidance at the national level as well as in all 50 states and the District of Columbia. In this section, the national and state reports and guides for roundabouts and access management identified in the methodology section are analyzed.

4.1.1 National Guidance for Access Management

The primary authority on access management in the United States is the TRB Access Management Committee (AHB70). The TRB Access Management Committee along with FHWA and FDOT published the *Access Management Manual* in 2003 as a comprehensive resource on state-of-the-art practices for the use of practitioners and stakeholders affected by access management actions. Besides the *Access Management Manual*, a limited number of guides or informational reports exist at both the national and state levels that include access management principles; even fewer address access management principles in the context of roundabouts. Based upon their listing on the FHWA website, the documents below are reviewed. The documents are presented in reverse chronological order.

- A Policy on Geometric Design of Highways and Streets (Green Book), 6th Edition, AASHTO, 2011.
- NCHRP Synthesis 404: State of Practice in Highway Access Management (Gluck and Lorenz, 2010).
- NCHRP Report 548: A Guidebook for Including Access Management in Transportation Planning (Rose et al., 2005).
- NCHRP Synthesis 351: Access rights: a synthesis of highway practice. (Huntington and Wen, 2005).
- NCHRP Report 524: Safety of U-turns at Unsignalized Median Openings (Potts, 2004).
- NCHRP Synthesis 337: Cooperative Agreements for Corridor Management (Williams, 2004).
- TRB Access Management Manual (TRB, 2003).
- NCHRP Synthesis of Highway Practice 332: Access Management on Crossroads in the Vicinity of Interchanges (Butorac and Wen, 2002).
- NCHRP Synthesis 304: Driveway Regulation Practices (Williams, 2002).
- NCHRP Report 420: Impacts of Access Management Techniques (Gluck, Levinson, and Stover, 1999).
- NCHRP Report 395: Capacity and Operational Effects of Midblock Left-Turn Lanes (Bonneson and McCoy, 1997).
- NCHRP Report 348: Access Management Guidelines for Activity Centers (Koepke and Levinson, 1992).

4.1.1.1 A Policy on Geometric Design of Highways and Streets (Green Book), 6th Edition, AASHTO, 2011. This book contains ten chapters: highway functions, design controls and criteria, elements of design, cross-section elements, local roads and streets, collector roads and streets, rural and urban arterials,

freeways, intersections, and grade separations and interchanges. Sections that discuss access management are the highway functions (chapter 1), access control and access management (section 2.5), elements of design (chapter 3), rural and urban arterials (chapter 7), types and examples of intersections (section 9.3), and roundabout design (section 9.10). Roundabouts and the types of roundabouts are defined in section 9.3. Section 9.10 includes aspects of roundabout geometry, size and space needs, and fundamental principles (speeds, lane balance and continuity, appropriate natural path alignment, design vehicle, non-motorized users, and sight distance and visibility). Sight distance, as one of the access management aspects, covers two types, SSD and ISD.

This document provides general information on the use of access management measures for all types of roadways for all contexts including roundabouts, but it does not specify any measure that is applied only to roundabouts. Detailed design standards are provided for local rural roads, local urban streets, special-purpose streets such as recreational roads and resource recovery roads, collectors, arterials, and freeways (Chapters 5 through 8). Geometric design elements include sight distance, vertical, and horizontal alignment. Sight distance features are described for different types of intersections, including three-leg and four-leg with and without channelization, and roundabouts. Frontage roads are also explored because they impact adjacent properties at urban arterials or freeways that do not have direct access due to access controls.

4.1.1.2 NCHRP Synthesis 404: State of Practice in Highway Access Management (Gluck and Lorenz, 2010). This document provides a complete review of access management, with the aim of reviewing current administration and practices in all 50 states. Surveys were conducted at all 50 state agencies with a 100 percent response rate. The surveys cover the content of policies and programs, program implementation, and its reported effectiveness. The review included access management programs in the states of Virginia, North Carolina, Indiana, Minnesota, Oregon, Louisiana, California, and New Jersey, as specific examples of current practices.

Based on the survey results, most states have utilized access management practices, with two-thirds of those keeping the formal programs. Access management programs are commonly used on the driveway permit level (92%), the project level (78%), the corridor level (64%) and the statewide level (60%). The most important aspect of implementing access management programs include a strong organizational commitment. Meanwhile, the barriers to implementation are political resistance, human and funding resources, and organizational and institutional limitations. "Other common barriers cited included a lack of education and training opportunities, resistance by the development community, limited coordination with local governments, legal issues, and a lack of vision" (pp. 106, Gluck and Lorenz, 2010). In addition, this synthesis gives complete links to all access management documents maintained by the state DOTs and individual researchers. In conclusion, this research presents aspects of access management that may contribute to program success. These elements include a strong access management authority, a framework for an access classification system, an access committee, an accountable and dedicated staff for access management, access champions, a legal case history, case studies, education and training, outreach to the affected parties, stakeholders cooperation, a statewide master plan, and having monitoring and evaluation programs in place.

4.1.1.3 NCHRP Report 548: A Guidebook for Including Access Management in Transportation Planning (Rose et al., 2005). This report describes best access management practices for highway systems across the country, and offers guidance on including access management in transportation planning. The report identifies several benefits of access management, such as increased safety for vehicles and pedestrians, environmental efficiency, access to properties, protection of physical integrity, coordination between land use and transportation, and protection of the intended access function state and regional roadways. It is a guidance document for the implementation of access management elements on a general scale for transportation planning and it recognizes different forms and styles of access

management across the country. The report is organized round the type of transportation plan; for example: overall planning, long-range plans, and corridor and sub-area planning. Therefore, it is evident that the broad range of variables and the context-dependent nature of access management have resulted in few investigations at a local level or case studies with specific examples.

4.1.1.4 NCHRP Synthesis 351: Access rights: a synthesis of highway practice. (Huntington and Wen, 2005). The purpose of this study is to understand on-going practices of highway access management. A national survey was conducted with follow-up interviews to explore three specific concerns about access rights: acquisition, management, and disposal. Three case studies were selected in Montana, Ohio, and Oregon to explore the on-going practice of access management. While the acquisition of complete access control has been a successful method in reducing current and future access to a roadway, efforts to implement partial access control have not had similar success in some agencies. In that regard, engineering and planning analysis is required to place both the driveways and the attached access control for those driveways.

4.1.1.5 NCHRP Report 524: Safety of U-turns at Unsignalized Median Openings (Potts, 2004). This report contains the guidelines for evaluating various designs of unsignalized median openings based on safety and operational performance. With the focus on urban/suburban arterials, this research categorizes median openings into 17 types of median opening designs and performs field studies at 26 urban sites and 12 median openings on rural arterials. In addition, this report presents the current design policies and practices of highway agencies obtained from mail surveys of 35 state and 30 local highway agencies. Crash rates at U-turn and left-turn maneuvers at unsignalized median openings are low. More specifically, the average of U-turn plus left-turn accidents per median opening per year at urban arterial corridors is 0.41, and the same average at rural arterial corridors is 0.20. This study recommends that the midblock median openings be taken into account as an option for either three or four-leg intersections. Also, the combination of directional median openings and directional midblock median opening(s) may be considered as an option to conventional median openings at three or four-leg intersections.

4.1.1.6 NCHRP Synthesis 337: Cooperative Agreements for Corridor Management (Williams, 2004). This research focuses on cooperative agreements between two or more agencies for corridor management. The research examines ongoing practices in cooperative agreements by looking at surveys from 22 agencies at both state and provincial levels. Five cases were selected: Arkansas, Wyoming, Colorado, Florida and California. Reviews of these cooperative agreements include: resolutions, memorandums of understanding, intergovernmental agreements, public-private agreements, and elements of corridor-management agreements. Issues found on cooperative agreements for corridor management include the agencies' lack of understanding about corridor management, a lack of agency leadership in corridor management, and opposition from the local community or no public acceptance. In terms of implementation, the problems are local commitment, legal and political concerns, and calls for technical assistance.

To reach effective agreements, every affected stakeholder should compromise and interact with others as equal partners and consider input from all agencies on the processes needed to implement the suggested agreement. Common vision, an integrated point of view for corridor management, and the willingness of those stakeholders to work together towards the same vision, may build the foundation for effective corridor management.

4.1.1.7 TRB Access Management Manual (TRB, 2003). This manual explores the general benefits of managing access to roadways, explaining how access management can be achieved, its aspects and principles, as well as the roles of various institutions in access management.

Access management affects safety, operations, economic factors related to the retail or commercial market and property values, land use, and the environment. Several studies mentioned in this report showed that the crash rate is reduced as the number of access points per mile is reduced, when there is a raised median, and when U-turns are accommodated instead of direct left turns. This manual also includes a summary of research on the safety and operational effects of Access Management Techniques (TRB, 2003, p. 19). Furthermore, it shows that business owners' concerns about economic downturn are insignificant, since left-turn restrictions in Texas and median changes in Florida did not affect the behavior of regular customers. Access management may influence the surrounding market areas and property values. Even commercial strips without proper access management may increase in property value. Furthermore, access management may help to sustain economic development in an area. Nevertheless, the same area may experience economic decline if poor access management is employed. Lastly, land use and environmental effects of access management include aesthetics, unification of activity centers, maintaining the capacity of available roadways, minimizing the environmental impact of individual access roads, and more efficient fuel consumption.

Three basic steps in implementing access management to a roadway are defining access categories, establishing access management standards, and assigning categories to the roadways or roadway segments. Initial factors to be considered are the degree of roadway importance, roadway characteristics, land use and growth management objectives; and the current and predicted flows of general transit as well as pedestrian and bicycle traffic. Four general aspects of developing access management standards include medians, degree of urbanization, speed, and safety (TRB, 2003, p. 71). Finally, the assignment of categories in roadway systems needs to take into account the following factors (p. 77):

- The intended function of the roadway as a component of a complete transportation system network;
- The roadway segment's environment (rural and undeveloped, urban fringe, sub-urban, urban, and densely developed or urban core);
- The availability of a supporting roadway system to supply alternative access; and
- The desired or appropriate balance between safety and frequency of access.

4.1.1.8 NCHRP Synthesis of Highway Practice 332: Access Management on Crossroads in the Vicinity of Interchanges (Butorac and Wen, 2002). This document reviews current practices in access location and design of crossroads in the vicinity of interchanges. Eight case studies were selected—three for new interchanges and five for retrofit interchanges. Varying degrees of access management on the crossroads in the vicinity of interchanges are employed by state and provincial agencies. The responding agencies in nine out of 36 states have legislative support for the access spacing standard, by adopting those into regulations. In this document, it is mentioned that even though agencies could use different factors in determining access spacing requirements, a number of them were establishing a spacing of 100 ft. for urban and 300 ft. for rural interchanges following the 1991 AASHTO recommendations. In practice, the access spacing standards for crossroads range from zero to 1,320 ft., with only half of the agencies having detailed methodology for calculating the actual distance. Agencies use four different reference points to measure the access spacing distance to the nearest downstream intersection.

Important factors that contribute to the spacing distance and appropriate crossroad locations are: turning movement complexity, design speed, surrounding land use and environment, crossroad classification, and level of interchange. Other findings are related to issues on putting access management into practice. Barriers to access management implementation could be conquered by having consistent access management policies, integrating the process of planning, designing, and operating, as well as reserving the interchange facilities and the downstream access location points on the crossroads.

4.1.1.9 NCHRP Synthesis 304: Driveway Regulation Practices (Williams, 2002). This research examines state and local agencies' surveys for their driveway policies. Along with a literature review about

driveways, the following objectives are presented: (1) review the current practice of driveway regulations, (2) present state and local practice regarding driveway regulations, (3) determine the impact of the driveway regulations, and (4) find the issues and lessons learned from the cases. Suggestions for effective driveway regulations include having consistent decisions and enforcement, a pre-application process, strong statutory authority, up-to-date design standards, and field reviews. Other important aspects are stakeholders' active communications and coordination, competent staffs, and public education of driveway regulations.

In NCHRP Synthesis 304, specific distances for driveways are provided for South Carolina. More specifically, at South Carolina, the access spacing standards depend on the operating speed. The space between two driveways is set to a minimum of 100 ft. for operating speeds of 30 mph or less and to a minimum of 350 ft. between driveways on roads with speeds of 55 mph or more. These standards may be modified to accommodate unique cases but space less than 40 ft. between two one-way driveways is nowhere allowed. This document refers to driveway width for the Washington county in Oregon where a residential driveway must be between 12 and 24 ft. wide, unless special permission is obtained for increasing the width and a commercial driveway should be between 15 and 40 ft. wide.

4.1.1.10 NCHRP Report 420: Impacts of Access Management Techniques (Gluck, Levinson, and Stover, 1999). This report focuses on the methods for evaluating particular access management techniques in terms of safety and traffic operations. This research identifies available techniques, and collects and analyzes the methods and data from various sources. The priorities for access management analysis are:

1. Traffic signal spacing
2. Unsignalized access spacing
3. Corner clearance criteria
4. Access separation at interchanges
5. Median alternatives
6. Left-turn lanes
7. U-Turns as alternatives to direct left turns
8. Right-turn lanes
9. Types of driveways
10. Frontage roads

This report reaches several conclusions. Crash rates are higher where signal density is higher, or where un-signalized intersections are more closely spaced. Safety and operations aspects are better if there is more corner clearance. Safety is also associated with raised medians. Left-turn storage lanes upgrade safety and capacity by providing spaces for turning vehicles. Indirect left-turns or U-turns may improve safety, capacity and travel time. Problems can exist if frontage roads are located too close to the ramp terminal. Frontage roads along freeways may need to be allocated properly to decrease arterial left turns, weaving movements, and enhance the access.

4.1.1.11 NCHRP Report 395: Capacity and Operational Effects of Midblock Left-Turn Lanes (Bonneson and McCoy, 1997). This research provides a methodology to evaluate midblock left-turn treatments and the guidelines to select the appropriate raised-curb medians, two-way left-turn lanes, and undivided cross sections alternatives for intersections. Three models were evaluated: the operation model, safety model, and access impact model. Data to build the models came from 32 field studies in eight cities and four states, along with information obtained from the interviews of 165 business owners and managers with businesses along four arterials in four cities and three states and 117 additional traffic simulation runs to obtain more traffic data. While this research was completed near traditional signalized and un-signalized

intersections, the concerns raised here may be applicable to mid-block left-turn treatments near roundabouts.

This research focuses on the two treatments—an undivided cross section and two-way-left-turn lanes (TWLTL). Important findings from this research include: (1) decreasing performance of unsignalized intersections when the proximity between intersections is closer, (2) an undivided cross section may give more delay than the raised-curb median and TWLTL, (3) when the demand is 40,000 vehicles per day or less, any of the left-turn treatment types performs without congestion, (4) safety analysis shows higher frequency of crashes on street segments with higher traffic demands and denser driveways and public streets, (5) field studies show no change in the provided access to adjacent properties after the retrofit of left-turn treatment, (6) business owners believe that changing from an undivided cross section to either 330-ft-openings of raised-curb median or TWLTL may enhance business and traffic conditions; meanwhile, they also believe that 660-ft-openings may not improve those conditions if the changing occurs from 330-ft-openings of raised-curb median or TWLTL, and (7) business owners consider that customers hold service or quality to be more important than property access.

4.1.1.12 NCHRP Report 348: Access Management Guidelines for Activity Centers (Koepke and Levinson, 1992). This report provides the access management guidelines for activity center. Although it focuses on access management near activity centers, the principles discussed in this document can be more generally applicable to the use of access management in other contexts. Overall, the purpose of access management is “to preserve the functional integrity and operational viability of the road system (p. 1)”. Taking the main definition of access management as “the process that provides or manages access to land development while simultaneously preserving the flow of traffic on the surrounding road system in terms of safety, capacity needs, and speed” (Koepke and Levinson, 1992, p.1), this document considers three key elements for access management: (1) specifying the control access with various roadway classifications, (2) identifying a method to have special permission once it was determined that proper access could not be built, and (3) finding ways to implement the standards.

The document presents the revised guidelines for managing access on streets and highways in the vicinity of activity centers. The information provided was obtained by interviewing state and local government officials, as well as activity center developers and managers. This report discusses the benefits of access management including reducing development costs and increasing safety. The ten chapters of this document focus on the broad guidelines for building up access management programs. In the end, this document proposes that programs should have proper access management codes that include access control and spacing criteria; design standards; and traffic permit procedures and requirements.

4.1.2 States' Guidance for Access Management

State Documents that refer to access elements are roadway or highway design/manuals, access management manuals and driveway manuals. The listed documents can be found and downloaded from state DOT websites about Access Management and from NCHRP Synthesis 404, *State of Practice in Highway Access Management* (Gluck and Lorenz, 2010), which includes information on where to find each state document on access management. Twenty-one DOTs include access management documents on their websites. The complete list and state DOT website links can be found in Appendix B. Most webpages contain information about access management, and the aspects that should be considered. The websites also include links to design manuals and other related documents.

4.1.2.1 Access Management Guidelines. Table 10 shows that state DOTs have various types of documents mentioning access management. Forty-three states, including the District of Columbia, have incorporated access and/or access management into their planning and design policies. More specifically, 19 states have access management manuals, separate from general design manuals. Eleven state DOTs mention access management or design manuals, while another 16 DOTs have other related documents with other names. The links to those documents can be found in Appendix B.

Table 10. Main Documents of the Access Management - Related State DOTs Guidebooks

Access Management Manual/Guidebook	Roadway/Highway Design Manual	Other Related Documents
Alabama (2013)	Arizona (2012)	State Highway Access Code/Manual:
Florida (2009)	California (2012)	Colorado (1998)
Idaho (2001)	Connecticut (2012)	Delaware (2011)
Indiana (2009)	Illinois (2010)	District of Columbia (2010)
Iowa (IowaDOT, 2012)	Massachusetts (2006)	Maryland (2004)
Kansas (2013)	Montana (2007)	Wyoming (2005)
Michigan (2001)	New York (2002)	Driveway Manual or/and Encroachment Control:
Minnesota (2008)	Utah (2007);	Georgia (2009)
Mississippi (2012)	North Dakota (2009)	West Virginia (2004)
Missouri (2003)	South Dakota (web, 2013)	Access Connection Policy/Rules:
Nevada (1999)	Washington (2012)	Louisiana (2012)
New Jersey (2013)		Maine (2005)
New Mexico (2001)		Access Control Policy:
Ohio (2001)		Nebraska (2006)
Oregon (2012)		Washington (2009)
South Carolina (2008)		Wisconsin (FDM, 2011)
Texas (2011)		Right of Way Manual:
Vermont (1999)		Utah (2006)
Virginia (2007)		Montana (2007)
		Driveway Permit/Access :
		New Hampshire (2000)
		North Carolina (2003)

Source: Compilation from DOT websites

The format of these manuals and guidebooks is similar to the NCHRP Synthesis 404, *State of Practice in Highway Access Management*. However, this report updates the NCHRP Synthesis report, which was completed in 2010, because many states prepared or revised their guidelines after the NCHRP study. Of the 43 states that have access management-related documents, 16 state guidelines, including Washington DC, were developed during or after 2009. As a highlight, *State of Practice* conducted surveys of all 50 states and obtained comprehensive information about the state DOT program elements. The survey responses are shown in Appendix C (Gluck and Lorenz, 2010, p.47). In contrast, this research explores DOT websites and locates access management documents and resources on those sites.

4.1.3 National and State Guidebooks for Roundabouts

National Guidebooks. Several national guidebooks were written about roundabouts as they became more popular and gained support from designers and communities around the country. The first highway guide for roundabouts was written by FHWA in the late 1990s. Both the AASHTO *Policy on Geometric Design of Highways and Streets* (2011) and the FHWA *Roundabouts, An Informational Guide* (Robinson et al., 2000) provide the current national standard on design guidelines for roundabouts, as well as all other traffic

engineering and design aspects across the country. Other national guidebooks and reports that govern roundabout design in the United States include the following NCHRP reports:

- NCHRP Report 672: Roundabouts: an informational guide. Vol. 672, (Rodegerdts et al., 2010).
- NCHRP Report 674: Crossing Solutions at Roundabouts and Channelized Turn Lanes for Pedestrians with Vision Disabilities, (Schroeder et al., 2008).
- NCHRP Report 572: Roundabouts in the United States. Report 572, (Rodegerdts et al., 2007).
- NCHRP Synthesis 264: Modern roundabout practice in the United States, (Jacquemart, 1998).

4.1.3.1 NCHRP Report 672: Roundabouts: an informational guide. Vol. 672, (Rodegerdts et al., 2010). This second edition of the roundabout guide is comprehensive, covering planning, operation, safety, geometric design, traffic design landscaping, and system considerations. In one section on planning, this document compares operational performance from the roundabouts with intersection controls, such as TWSC, AWSC, and signal control. The operation section includes capacity and performance analysis of traffic operation, e.g. degree of saturation, delay, queue length, and field observation. Specifically for geometric design, this document explains how to design roundabouts with:

- Design speed;
- Vehicle paths;
- Inscribed circle diameter;
- Design vehicle;
- Non-motorized design users, entry width (tapper length, additional lane length, and flare length);
- Circulatory roadway width;
- Central island;
- Entry curves and exit curves;
- Pedestrian crossing location and treatment;
- Splitter island;
- Stopping sight distance (SSD);
- Intersections sight distance;
- Vertical consideration (profiles, super-elevation, and drainage);
- Bicycle provisions;
- Parking and bus stop locations; and
- Right-turn bypass lanes.

These design standards are specified for double-lane roundabouts and rural roundabouts. Specific designs include entry curves, and exit curves to avoid path overlap in double-lane roundabouts; visibility, curbing, splitter island, and approach curves for rural roundabouts. Additionally, these guidelines explore mini-roundabouts, which are not included in this research.

In the safety section, this document reviews conflict points for different users, and common crash types in roundabouts. Signage, pavement markings, illumination, work zone traffic control, and landscaping are explored in the section on traffic design and landscaping. In the last section, system considerations focus on traffic signals at roundabouts, at-grade rail crossings, closely spaced roundabouts, roundabout interchanges, roundabouts in an arterial network, and microscopic simulation.

However, this document does not explore how roundabouts can accommodate large vehicles or how to design them with more than two entry lanes. It does not include information about specific “legal or policy requirements and language.” This report is the one most frequently adopted by state DOTs for their roundabout design or guide documents.

4.1.3.2 NCHRP Report 674: Crossing Solutions at Roundabouts and Channelized Turn Lanes for Pedestrians with Vision Disabilities, (Schroeder et al., 2008). This document discusses the safety of

roundabouts and channelized intersections for pedestrians with vision disability. The authors conducted the study using an experimental design (before and after) for treatment installations, pedestrian models, and simulation. Treatments for pedestrians included the pedestrian-actuated, flashing-yellow beacon, and on-pavement sound strips for visually-impaired pedestrians. The study took place on single-lane and double-lane roundabouts. The former were in Charlotte, NC; Raleigh, NC; and Golden, CO, and the latter in Golden, CO. The study includes measures for crossing opportunity, utilization of crossing opportunity, delay, and safety. One of the conclusions is that delay is reduced after the treatment for single-lane roundabouts. In other words, accessibility for pedestrians is improved. However, the two-lane roundabout is challenging and may not be accessible for pedestrians with vision disability.

4.1.3.3 NCHRP Report 572: Roundabouts in the United States. Report 572, (Rodegerdts et al., 2007).

The main purpose of this research was to describe the methods of predicting safety and operational aspects of roundabouts. In addition, this report also modified the design criteria related to the safety and operations of roundabouts. The document includes four main sections: safety performance, operational performance, geometric design, and pedestrian and bicyclist observation.

In addition to analyzing the applicability of various crash prediction models to the United States, this document investigates safety performance of roundabouts using an empirical Bayes before-after procedure. This study found large safety improvements from converting TWSC and signalized intersections into roundabouts, but found no safety improvement compared to AWSC intersections. Additionally, safety improvements for single lane roundabouts were greater than multi-lane roundabouts. This study also found that rural roundabouts had greater safety performance than urban or suburban installations and that any safety benefit declined with increases in AADT.

Next, the operational performance review included entry capacity and control delay models for one-lane and multilane roundabouts. In general, this study found that existing models do a poor job of estimating the capacity for roundabouts. To correct for these errors, the authors propose a series of capacity models that are more effective than existing models with calibration. However, control delay models were found to be effective. This study concludes that LOS criteria for roundabouts are similar to those at unsignalized intersections.

Furthermore, aspects of design that may be important to consider are: acceleration and deceleration effects on speeds, ISD, and design detail on multilane roundabouts such as vehicle path alignment, lane width, and driver information regarding how to use lane markings. Moreover, this study did not find any significant effects of safety for pedestrians and bicyclists. In addition, there is concern about the design of exit lanes to increase the awareness of pedestrians in crosswalks. Multilane roundabout design should carefully avoid path overlap, and crosswalk visibility needs to be carefully designed to address the reduced tendency of drivers in multilane roundabouts to yield to pedestrians.

4.1.3.4 NCHRP Synthesis 264: Modern roundabout practice in the United States, (Jacquemart, 1998).

This report pre-dates other national research on roundabouts. The report explored North American (i.e., U.S. and Canadian) practices at the time it was developed (1998). It also provides examples of guidelines from Australia, the United Kingdom, France, Switzerland and Germany. Specific topics addressed include safety, capacity and delay, issues of roundabouts for various users, location criteria for roundabouts, and examples of the use of roundabouts in the United States.

This synthesis includes the results of a survey conducted among all state DOTs in the United States as well as their counterparts in the Canadian provinces. The survey incorporated the responses of those state DOTs regarding the willingness to build more roundabouts in their jurisdiction, and design guidelines from other countries or states that they used as precedence. Specifically, for making a safety analysis field study, this research included a safety analysis that examined before and after scenarios of 11 roundabout

sites in the United States. After roundabouts were installed, the total number of crashes was reduced by 37% at these 11 sites.

The authors found that the size of roundabout diameters affect the number of total crashes and injury crashes, as smaller diameters of 37 m. or 121 ft. show a 53% decrease in total crashes and a 73% drop in injury crashes. Overall, the samples of this study showed a decrease in delays of about 75% with the roundabouts compared to prior traffic control methods at intersections. Issues concerning pedestrians and bicyclists were related to “the absence of clear right-of-way control (p. 2). In the case of one-lane and low-speed roundabouts, it was suggested the bicycle lane should merge into the roundabout and the bicyclist should share the lane with the cars. For multi-lane roundabouts, it was recommended that bicyclists should have separate bike paths, be assigned to a shared path with pedestrians, or be rerouted.

This synthesis shows the marked benefits of roundabouts regarding safety, delay, and capacity. In addition, this research agrees that roundabouts provide aesthetic and urban design benefits.

4.1.4 State Guidance for Roundabouts

The state guidebooks are usually mentioned on state DOT websites. Twenty-six states have roundabout websites with varying degrees of information. Links to other states’ roundabout websites and national guidelines are also found on most of those websites.

In addition to national guidance on roundabouts, access management, safety, and capacity, a handful of states are leading the way in providing statewide guidance that supplements the national guidance. Those states supplement the national guidance with various types of state-level documents. For example, many included the roundabout design on the roadway manual. Some states have specific links to the design of roundabouts. Furthermore, Virginia DOT placed the roundabout design in the access management guidance, which relates to the purpose of this project. The activities of fourteen states including Arizona, California, Iowa, Kansas, Kentucky, Maryland, Michigan, Minnesota, New Hampshire, Pennsylvania, Virginia, Washington, and Wisconsin were selected for further examination because they have additional guidance beyond that provided in national documents. These are described in detail below. Roundabout guidance in Florida is also reviewed in great detail later in this chapter. This review includes the extent of roundabout information, roundabout users’ guide(s), existing roundabout design guidance, access management guidance, and driveway spacing and design guidance. Several of the state guidebooks base their guidance on the FHWA *Roundabouts: An Informational Guide* (Robinson et al., 2000) and NCHRP Report 672: *Roundabouts, An Informational Guide*, Second Edition, (Rodegerdts et al., 2010). Particular attention is given to state guidance on access management, driveways, safety, and roundabout capacity as they apply to roundabouts.

Table 11. Roundabout States’ Design Guidebooks Reviewed in this Document

Roundabout Guide Document	Facility Development Manual	Access Management Design Standard	Roadway or Highway Design Manual
Florida (1996, 2000, 2012)	Wisconsin (2011)	Virginia (2007)	New Hampshire (2007)
Arizona* (2003)			Iowa (2009)
Kansas (2003)			Minnesota (2009)
Pennsylvania (2007)			Kentucky (2010)
California (2007)			Maryland (2011)
Iowa (2008)			Washington (2011)
Michigan (2011)			Arizona (2012)
Maryland (2012)			

* - cannot be accessed online

Arizona. *Roundabouts: An Arizona Case Study and Design Guidelines* (Lee et al., 2003) and *Roadway Design Guidelines, Section 403* (AzDOT, 2012) are two documents from Arizona DOT (AzDOT). The first is a 260-page document that discusses the case studies of roundabouts in Arizona. The second includes a six-page section on roundabout design. Both design manuals follow the national guidelines about roundabouts

California. The main document about roundabouts in California is *Roundabout Geometric Design Guidance* (Caltrans, 2007). This 113-page document has three main chapters: vehicle operations assessment, pedestrian and bicycle considerations, and geometric design considerations. The research establishes policies and standards for Caltrans roundabouts. The research found that the successful performance of a roundabout is more a result of outputs (operational and safety performance, and accommodation of users) than inputs (individual design dimensions). This document recommended modification of *Roundabouts: An Informational Guide* (Robinson et al., 2000) in regard to acceleration and deceleration effects.

Iowa. The *Planning-Level Guidelines for Modern Roundabouts, Technical Memorandum* (Hallmark and Isebrands, 2008) and *Design Manual Chapter 6, Geometric Design, 6A-3 Modern Roundabout - General Guidance* (IowaDOT, 2009) are the two guidance documents used for roundabouts in Iowa. The first is a 32-page document that provides the Iowa DOT with information and guidance on roundabout policies, design guidelines, and public education. It develops a roundabout task force, documents best practices of states with successful roundabout programs, develops implementation guidelines, develops draft roundabout policies, and assists in public education about roundabouts. The second document, written by the Iowa DOT, is a separate chapter of the Geometric Design manual. A section of the chapter (16 pages long) focuses on modern roundabouts for Iowa.

Kansas. *Kansas Roundabout Guide, A Supplement to FHWA's Roundabouts, An Informational Guide* (Kittelton & Associates, and Transystem Corporation, 2003) is a 176-page document that shows supplemental aspects, such as differentiating traffic circles from roundabouts, and detailing roundabout selection criteria. This includes adding roundabout categories on the design characteristic table (whether urban or rural roundabouts and whether single or double lane), as well as details of the design process. The guide highlights five projects in Kansas with respect to curb and pavement design, signage on urban, suburban, multilane roundabouts, luminance for intersections based on pavement classification (the Portland cement concrete surface and typical asphalt surface), and roadway classification.

Kentucky. Kentucky Transportation Cabinet (KYTC) has *Design Guidance for Roundabout Intersection* (KYTC, 2010) to provide specific explanations of how Kentucky may review and approve roundabouts. This document also looks at warrant analysis and operational analysis for traffic dynamics. The operational analysis takes into account the aspects that impact roundabout capacity, such as geometric design, and critical headway.

Maryland. Two documents from Maryland DOT are: *Chapter 3C—Roundabout Markings* (Roundabout Design Guidelines, 2011), and *Roundabout Design Guidelines* (Maryland State Highway Administration, 2012). The first document includes markings for one-, two-, and three-lane roundabouts, as well as crosswalk, pedestrian, and bicyclist markings in roundabouts. The second document covers design and operations aspects for roundabouts.

Michigan. The first document about roundabouts in the state of Michigan is *Evaluating the Performance and Safety Effectiveness of Roundabouts* (Bagdade, et al. Michigan Department of Transportation, 2011). This document compiles the geometric features and crash history of roundabouts within Michigan and also presents the Safety Performance Functions (SPFs) and Crash Modification Factors (CMFs) for roundabouts in the state.

Minnesota. MnDOT has roundabout design guidelines in the *Road Design Manual: Chapter 12—Design Guidelines for Modern Roundabouts* (MnDOT, 2009). It shows the enhancement table of typical inscribed circle diameters with daily service volumes, intersection control evaluation policy, a site requirement section, and special design features to accommodate specific land uses. Additionally, this document suggests RODEL and Assessment of Roundabout Capacity and Delay (ARCADY) as tools for intersection control evaluations.

New Hampshire. NHDOT has *Supplemental Design Criteria* (NHDOT, 2009). This is a five-page document that supplements the FHWA *Roundabouts: An Informational Guide* (Robinson et al., 2000) guidelines for roundabout design on New Hampshire state-maintained roadways. It mentions considerations for roundabout design, including operations (with attached capacity worksheet, and RODEL setting), and geometric design.

Pennsylvania. The main document about roundabouts in Pennsylvania is the *Guide to Roundabouts: Publication No. 414* (PennDOT, 2007). This 236-page document supplements the pedestrian provisions of FHWA's *Roundabouts, An Informational Guide* (Robinson et al., 2000) and provides consistent information regarding the planning, design, construction, maintenance and operation of roundabouts in Pennsylvania. This document also presents detailed requirements for detectable warning surfaces and other pedestrian features.

Virginia. Virginia's access management document, *Access Management Design Standards for Entrances and Intersection* (VDOT, 2007), includes information about roundabout in Chapter F-40 *Section 2, Intersection Design; Spacing Standard*. This 115-page document explains the process of roundabout design in Virginia, access management for highways, and pedestrian/bicyclist safety, by managing the number of entrances and restricting access from one or more directions. The state has adopted a policy on intersection design that includes the following principles: limit the number of conflict points, coordinate design and traffic control, avoid complex maneuvers, separate conflict points, favor major flows, segregate movements, accommodate pedestrians and bicyclists, consider the design vehicle, and consider a roundabout design.

Washington. *The WSDOT Design Manual—Chapter 1320 Roundabout* (WSDOT, 2011) is the principal document about roundabouts. A 50-page section gives information about procedures to design a roundabout in the state of Washington. Section 1320.11 refers to access, parking, and transit facilities around. Roundabouts. More specifically, the chapter includes information related to corner clearance, parallel roundabouts, U-turns, parking, and transit stops in the vicinity of roundabouts. This guidance indicated that no road approach connections to the circulating roadway are allowed at roundabouts unless they are designed as legs to the roundabout (WSDOT, 2011). For driveways close to roundabout, this guidance suggested that it is desirable that road approaches not be located on the approach or departure legs within the length of the splitter island (WSDOT, 2011). The minimum distance from the circulating roadway to a road approach is controlled by corner clearance using the outside edge of the circulating roadway as the crossroad (WSDOT, 2011). Right-in/right-out driveways are also preferred when designing driveway close to roundabout.

Wisconsin. The main document for roundabout guidelines in Wisconsin is *Chapter 11, Section 26: Roundabouts* (WisDOT, 2013). This 79-page report provides the general guideline for design and construction of roundabouts. It also provides the first supplementary guidance for shared-use paths for bicyclists. This guideline considers three aspects related to the location of driveways on the roundabout entry or exit: volume of driveways, operational impact, and sight distance between users. In addition, the chapter explains the RODEL software in detail. This chapter is currently being updated and HCM 2010, using locally developed gap parameters, will replace RODEL as the software tool to analyze roundabout capacity and operations (Patrick Flemming, Personal Communication, June 25, 2013).

4.2 State of Florida Guidance

4.2.1 Access Management Guidance in Florida.

The FDOT Systems Planning website (FDOT, 2014) does not specifically address planning for roundabouts. However, when 'roundabout' was used as the keyword on the search engine, several informational documents appear. The Florida DOT's Access Management site provides definitions and contains information about permits, training, and documents for access management, but does not provide specific guidance on access management near roundabouts.

Florida has two major handbooks related to access management. The first, the FDOT *Median Handbook* (2006) is an 81-page report that addresses several design considerations related to roundabouts. However, it does not explicitly detail anything about roundabout design or access management. The FDOT *Driveway Information Guide* (2008) is a 94-page report that addresses several guidelines for driveway design in Florida, such as sight distance at driveways, driveway location, and pedestrian factors, but does not make any reference to roundabouts.

The following sections review access management techniques in Florida. These include roadway classification, driveway design and spacing, corner clearance, median opening design/spacing, sight distance, turn-lane location and design, and auxiliary lane and design.

Roadway Classification. FDOT's State Highway Access Management Classification System and Standards (FDOT, 2010) contains roadway classifications based on access class, segment location and applicable spacing standards. FDOT segments access into seven classes: (1) Access class 1 is for limited access facilities that are designed for high speed and high volume traffic (e.g., interstate highways and Florida's Turnpike; (2) access class 2 roadways are highly controlled access facilities distinguished by the ability to serve high speed and high volume traffic over long distances in a safe and efficient manner; (3) access class 3 roadways are controlled access facilities where direct access to abutting land is controlled to maximize the operation of the through traffic movement; (4) access class 4 roadways are controlled access facilities where direct access to abutting land is controlled to maximize the operation of the through traffic movement; (5) access class 5 roadways are controlled access facilities where adjacent land has been extensively developed and where the probability of major land use change is not high; (6) access class 6 roadways are controlled access facilities where adjacent land has been extensively developed, and the probability of major land use change is not high; and (7) access class 7 roadways are controlled access facilities where adjacent land is generally developed to the maximum feasible intensity and roadway widening potential is limited.

A visual depiction of how Florida's roadway system fits in with the access management classifications is shown in Figure 20:

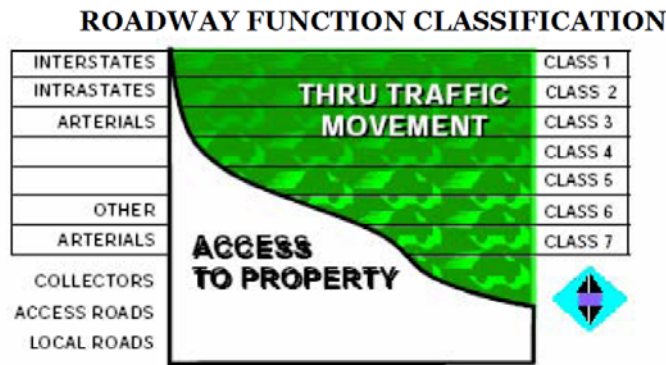

Figure 20. Roadway Function Classification in Florida (FDOT, 2010, p. 24)

Each of these roadway classifications has a set of spacing standards and other associated access management categories. For class 1 roadways, decisions on spacing are based upon whether a segment is located within a Central Business District (CBD) or CBD fringe for cities in urbanized areas. The spacing is one mile in the existing urbanized areas other than type 1; 2 miles in the transitioning urbanized areas; 3 miles in urban areas other than areas 1 and 2; and 6 miles in rural areas, respectively. Other classes have connection spacing standards based on the posted speed limit. Class 2 to Class 7 are defined as follows, according to their restrictiveness from the most to the least respectively (FDOT, 2010, p. 67). Access class 2 is further distinguished by a highly controlled, limited number of connections and median openings, and infrequent traffic signals. The land adjacent to access class 3 and 4 roadways is generally not extensively developed and/or the probability of significant land use change exists. These roadways are distinguished by existing or planned restrictive medians. Access class 5 roadways are also distinguished by existing or planned restrictive medians. Access class 6 roadways are distinguished by existing or planned non-restrictive medians or centerlines. Access class 7 includes only roadway segments where there is little intent or opportunity to provide high-speed travel. Exceptions to access management standards in this access class may be allowed if the landowner substantially reduces the number of connections compared to existing conditions. These roadways can have either restrictive or non-restrictive medians (FDOT, 2010).

Driveway Design and Spacing. In explaining the driveway design, FDOT provides the following figure to understand the elements of driveway location.

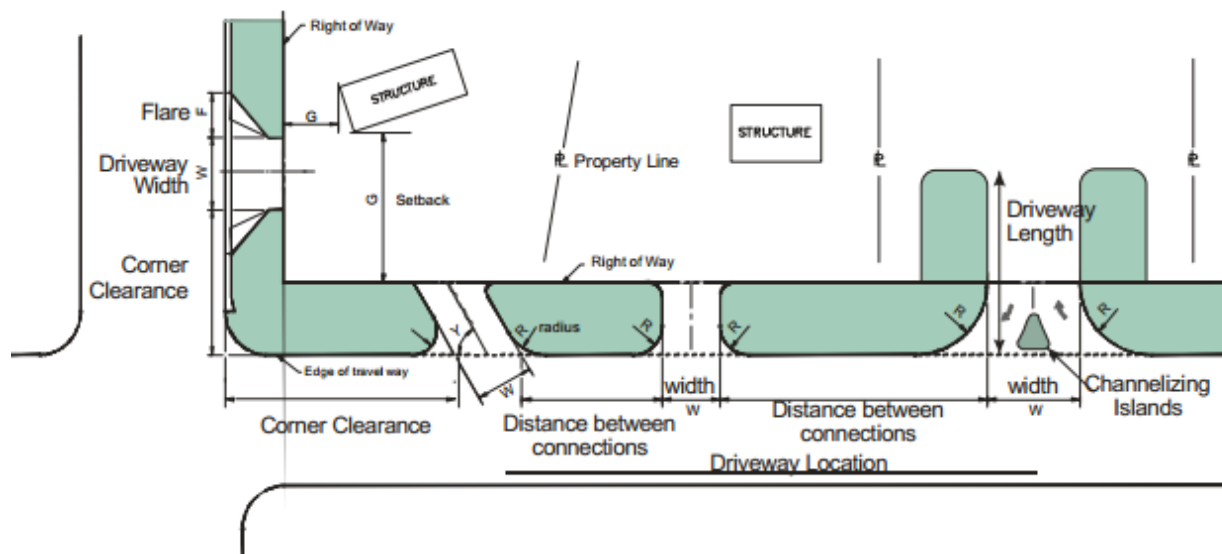

Figure 21. Driveway Design and Spacing (FDOT, 2008, p. 9)

The driveway features illustrated in Figure 21 are described in detail in page 9 of the Driveway Information Guide (FDOT, 2008) and are also provided below:

- Radius (R) – size of curved approach/exit of driveway
- Flare (F) – size of angled approach/exit of driveway
- Width (W) – space for vehicles operating on driveway
- Driveway Distance (D) – or spacing between driveways
- Corner Clearance (C) – similar to (D) but measured from a major intersection
- Angle (Y) – angle of driveway
- Setback (G) – distance from public right of way to the closest structure
- Sight Distance – length of road visible to the driver required for vehicles to make safe movements
- **Driveway Location** – position of driveway in relation to other traffic features such as intersections, neighboring driveways, and median openings
- **Driveway Length** – (also called “throat length”) distance needed into site to transition vehicles to the internal circulation system of the site
- **Grade** – slope of driveway
- **Driveway Traffic Separators/Channelizing Islands** – size and position of barrier separating traffic movements on the driveway
- **Right Turn Lanes** – separate lanes on roadway to facilitate right turns into driveway
- **Structure** – Building, Gas Island, Gate, etc.

Following NCHRP Report 548 A Guidebook for Including Access Management in Transportation Planning (Rose et al., 2005, p.40), FDOT’s Design Standards classifies driveways based on the expected volume and the type of traffic. The design standards for driveways are found in Standard Index 515 (FDOT, 2010). Additionally, FDOT gives land use examples of each category. For instance: the first category has examples of one or two single-family homes; the second category has three to 60 housing or apartment units, small offices in converted homes, or “mom and pop” businesses; the third category has small strip shopping centers, and gas station/convenience markets; and the last category has an example of a 150,000-ft shopping center, grocery/drugstore with ten to 15 smaller stores.

FDOT shows the construction designs for two primary shapes: “curbed flared driveway or the dropped curb” and the “radial return.” Unless the driveways are higher volume, the standards for “curbed flared driveway” are predominant in urban roadways. However, a few rural roadways may have curbs and gutters. For rural roadways, FDOT suggests following the rounded radial return design.

The *Driveway Information Guide* also explains how the driveway should intersect with on-street parking or bike-lanes, and where the effective turning radius should be increased from around 6 to 14 ft. The curb and effective radius are displayed in Figure 22.

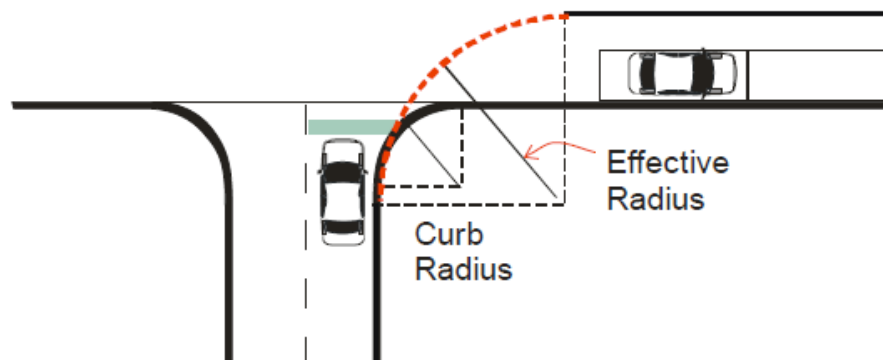

Figure 22. Effective Radius and Curb Radius (FDOT, 2008)

Additionally, the driveway design criteria for several land uses, such as shopping center, office complex, and convenience stores are suggested. This standard is adapted from *Transportation and Land Development* (2002) (see Appendix B, other state related documents, and Florida Median Handbook (FDOT, 2006)).

Ramp design spacing is also explained in this document. It is based on area types, such as urbanized, transitioning, and rural, as well as assumed posted speed. FDOT has the recommended minimum spacing. The dimension of ramp design spacing is calculated from on or off-ramp, as displayed in Figure 23. FDOT refers to the NCHRP Report 420 *Impacts of Access Management Techniques* for minimum ramp spacing (FDOT, 2008, p. 78). Under the circumstances when roundabouts are located close to highway interchanges, ramp design spacing must be considered. Small spacing between roundabout and interchanges could potentially compromise the operation of both roundabout functional area and ramps that enter/exit roundabout.

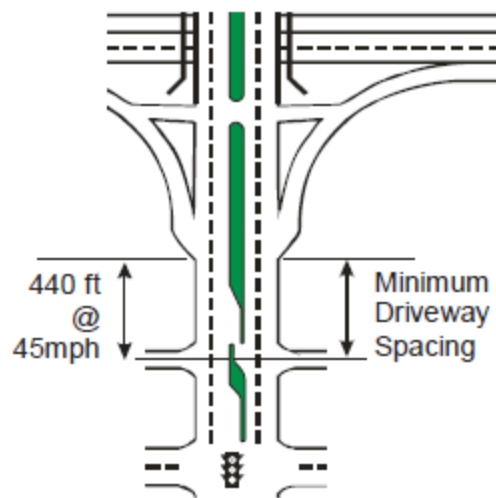

Figure 23. Ramp Spacing (FDOT, 2008, p. 78)



Figure 24. Roundabout at an Interchange (FHWA, 2006, p. 8)

Corner Clearance. According to the AASHTO Green Book, corner clearance means proper driveway placement so that a driveway is not within the influencing area of another driveway. FDOT's Driveway Information Guide displays the figure (Figure 25) of a driveway with an improper location to illustrate corner clearance.

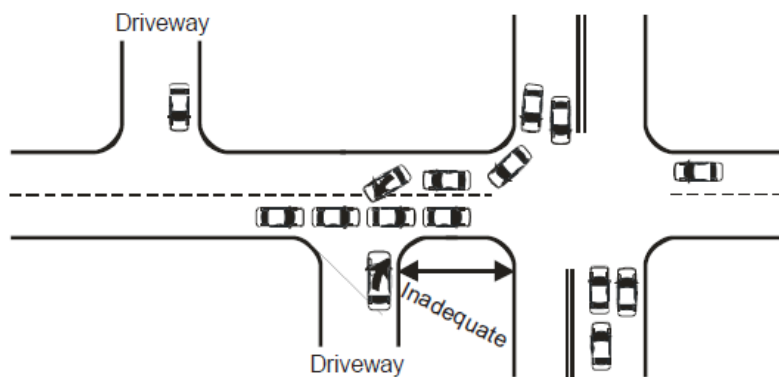

Figure 25. Corner Clearance (FDOT, 2008, p. 73)

Roadway classification determines the spacing for corner clearance, along with the speed limit on the roadway. FDOT also details the downstream corner clearance standard for a minor side street. Figure 26 illustrates the downstream corner clearance.

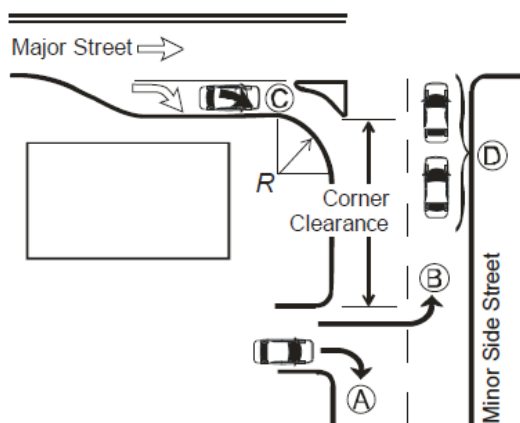

Figure 26. Corner Clearance for Downstream (FDOT, 2008, p.76)

The standard for downstream corner clearance is also defined by whether the intersection is channelized, (with a radius of 50 ft). For a radius of more than 50 ft, the standard applies for channelization downstream.

Median Opening Design/Spacing. FDOT applies the median opening standard based on the posted speeds and on the physical characteristics—whether the opening is full or directional. Median opening distances range from 330 to 2,640 ft. depending on opening type, design speed and roadway classification, as seen in Table 12. Access Management Standards from Rule 14-97 (FDOT, 2006, p. 15).

Table 12. Access Management Standards from Rule 14-97 (FDOT, 2006, p. 15)

Class	Medians	Median Openings		Signal	Connection	
		Full	Directional		More than 45 mph Posted Speed	45 mph and less Posted Speed
2	Restrictive w/Service Roads	2,640	1,320	2,640	1,320	660
3	Restrictive	2,640	1,320	2,640	660	440
4	Non-Restrictive			2,640	660	440
5	Restrictive	2,640 at greater than 45 mph Posted Speed	660	2,640 at greater than 45 mph Posted Speed	440	245
		1,320 at 45 mph or less Posted Speed		1,320 at 45 mph or less Posted Speed		
6	Non-Restrictive			1,320	440	245
7	Both Median Types	660	330	1,320	125	125

Sight Distance. This guidance is needed to improve safety. The sight distance standards include the SSD, the distance necessary to stop, and ISD. FDOT sets 14.5 ft. as the minimum driver eye setback. For new developments, the distance for SSD should follow the standard based on the design speed of the roadway.

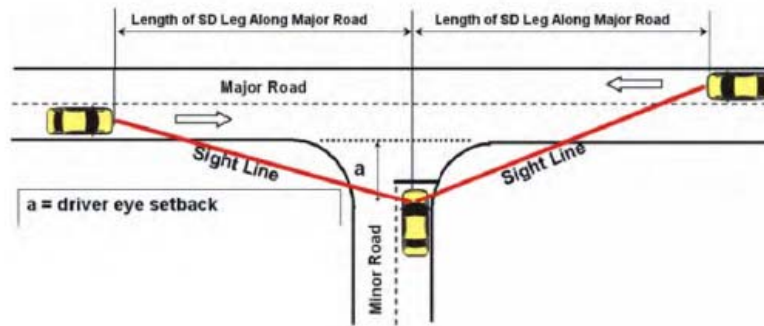

Note: FDOT will use 14.5' as the minimum driver's eye setback, and only in restrictive conditions where 17.8 ft, or greater cannot be achieved.

Figure 27. Sight Distance and Driver Eye Setback Driveway Information Guide (FDOT, 2008, p. 62)

Other than SSD and ISD, FDOT has sight distance standards for roadways upstream and downstream that have on-street parking. For a speed of 0 to 30 mph, it is suggested that the upstream lanes be at least 85 ft. and the downstream two lanes, at least 60 ft. With four lanes the distance should be 45 ft. For a speed of 35 mph, upstream is at least 100 ft. downstream for two lanes, and at least 70 ft. and four lanes at 50 ft.

Turn-Lane Location and Design. FDOT suggests the standard for a radial return design is used for an exclusive right-turn lane. Meanwhile, the flare driveway standard is for low volume driveways. The guideline gives classification of roadways based on the posted speed limit, and the number of right turns per hour, i.e. 45 mph or less with 80-125 vehicles, and over 45 mph with 35-55 vehicles. FDOT suggests having no median openings across the left-turn lane (FDOT, 2008, p. 77). The driveway should be located at least 100 ft. from the opposite median opening. This document also suggests having an additional pavement across the median opening because it may support the U-turn movement. FDOT suggests permitting left-turns across high volume roads, when joint and cross access exist. Figure 28 shows an example of joint and cross access.



Figure 28. Joint and Cross Access (FDOT, 2008, p. 86)

For another joint and cross access, the FDOT refers to the document *Managing Corridor Development, A Municipal Handbook* (Williams and Marshall, 1996), for the following information.

Auxiliary-Lane Location and Design. FDOT has the standard for intersection channelization design. First, the standard channelizes divisional islands, including pedestrian refuge islands, traffic separation, and traffic flow separation. According to Standard Index 515, the minimum width for a driveway divisional island is 4 ft. and the maximum is 22 ft. However, if the driveways are not included in the standard index, the minimum is 6 ft. and the maximum is 16 ft.

The Driveway Information Guide recommends the length for driveways that have parking movements should be at least 50 ft. to give space for one vehicle to enter (from the sidewalk). The preferred distance for parking movements is equal to or greater than 30 ft. from the roadway, and more than or equal to 20 ft. from the sidewalk.

This length is different for land uses with a drive-through. This document also suggests the spaces allow vehicle queues at fast-food establishments, banks, car washes, day care facilities, dry cleaners, and drive-through stand-alone drugstores. FDOT also suggests maximum queues for school bus stops, and driveways for staff, parents and students. This standard is based on critical peak morning and afternoon hours.

In addition to those standards, FDOT also makes suggestions for driveways near bus stops and transit facilities. The opposite sides of a roadway may result in jog maneuvers (for undivided roadways or those with two-way left-turn lanes (TWLTL) (FDOT, 2008, p79). As a consequence, FDOT recommends the roadway offset distances adapted from DOT.

4.2.2 Roundabouts Guidance for Florida

Several documents are identified as roundabout guidelines at FDOT. These include *Florida Roundabout Guide* (FDOT, 1996), *Roundabout Justification Study* (Chapter 16 in *Manual on Uniform Traffic Studies*, FDOT, 2000), *Florida Intersection Design Guide 2013* (FDOT, 2007) and *Bicycle and Pedestrian Considerations at Roundabouts* (Shen et al., 2000).

The 109-page *Florida Roundabout Guide* (FDOT, 1996), which details roundabout design and guidance in the state, was published earlier than FHWA's *Roundabouts, An Informational Guide* (Robinson et al., 2000). The Florida guide includes procedures to justify the need to build a roundabout, while the FHWA document does not. This guide is in the process of being replaced, with additional guidance being incorporated into other guidance documents; the state has officially adopted NCHRP 672, *Roundabouts, An Informational Guide* (Bansen and Sullivan, 2013). Other supplemental aspects of the Florida guide are explanations for using the SIDRA software. In addition, this document also considers other software, such as ARCADY, and RODEL. The Florida guide includes forms to determine capacity and other required materials to justify the use of a roundabout; much of this guidance has been sunsetted with the adoption of NCHRP 672, *Roundabouts, An Informational Guide* and the inclusion of Chapter 7 into the State's *Intersection Design Guide 2013*.

The second roundabout document is the *Manual on Uniform Traffic Studies*, Chapter 16 - Roundabout Justification Study (2000). Written by FDOT and published in 2000, this 16-page report is the last chapter in the FDOT *Manual on Uniform Traffic Studies* (MUTS). The MUTS establishes minimum standards for conducting traffic-engineering studies on roads under the jurisdiction of the FDOT. The chapter on roundabouts justifies their use in the State of Florida, and compares them to three other alternatives to intersection controls – traffic signals, TWSC, and AWSC. This chapter cites the 1996 FDOT *Florida Roundabout Guide* for specific guidelines on roundabout location, design, and operation.

The third document that provides information on roundabouts is the Florida Intersection Design Guide, 2013 For New Construction and Major Reconstruction of At-Grade Intersections on the State Highway System. This 226-page document includes chapters on intersection design concepts, geometric design,

signalization, signs and markings, objects and amenities, and roundabouts. It states that modern roundabouts should be considered for any new road or reconstruction project as they seem to provide safety and operational advantages. Consistent with other state guidance, the Intersection Design Guide adopts NCHRP 672, *Roundabouts, An Informational Guide* (2010) as the main guide for designing roundabouts in Florida. It mentions that roundabouts control right-of-way similar to signalization but offer more advantages than signalized intersections, such as reducing the conflict points within the intersection, reducing delay, no required power or timing such as with signals, lessening the number or turn lanes, eliminating the need for extra queuing space, and others. Roundabouts can also reduce right-angle crashes.

FDOT generally recommends up to two lanes in roundabouts unless there are specific needs in accommodating movements in spiral or “Turbo” roundabouts. In addition, driveways should not be allowed in the circulatory roadway unless there is enough demand to support their construction as additional legs of the roundabout.

Regarding roundabouts and access management, this document accepts that roundabouts can be used as part of an access management plan as they contribute to reducing downstream left turns because vehicles can perform U-Turns within the roundabouts and then access an area by turning right. Bicycles can access a roundabout as vehicles using the circulatory roadway or as pedestrian traffic using the sidewalks. Bicycle lanes should end at bypass ramps to allow bicycles to use the sidewalk if they prefer, always yielding to pedestrians. Pedestrian treatments at roundabouts are the same as in other intersection types. In case of bus routes passing through roundabouts, bus bays should be placed carefully on the near side of the roundabout approach so that will not create vehicle queues that spill back into the circulatory roadway. Bus stops located on the far side of the roundabout should have pullouts or be moved further downstream to the splitter island in order to avoid interrupting regular traffic.

As mentioned earlier in this report, adequate SSD has to be provided at roundabouts. Florida Intersection Design Guide adapts the SSD formula and the ISD requirements from NCHRP 672, *Roundabouts, An Informational Guide* (Equations 6-5-6-7, pp. 6-61-6-63 in Rodegerdts et al., 2010).

The fourth roundabout document is *Bicycle and Pedestrian Considerations at Roundabouts* (2000). Written by FDOT and published in 2000, this report examines topics of specific concern to bicyclists and pedestrians at roundabouts. The conclusions of this study are that if not properly designed, roundabouts can have higher bicycle crash rates than those of vehicles and pedestrians, and the multi-lane roundabouts create more tension and are less safe for bicyclists and pedestrians than one-lane roundabouts. The report recommends the use of additional bicycle facilities outside a roundabout if space is available. Also recommended are crossing provisions, and proper signage.

In addition to the above documents, FDOT presented a PowerPoint presentation—Roundabouts, Florida’s Implementation Strategy (Prytyka and Sullivan, 2012) at the 2012 Design Training Expo. This presentation captures supplemental aspects from *FHWA’s Roundabouts, An Informational Guide* (Robinson et al., 2000), especially on pedestrians, trucks, and pavement marking information.

4.3 National Guidance on Access Management in the Context of Roundabouts

Among all the national guidance documents on roundabouts and the documents on access management, only NCHRP Report 672: *Roundabouts, An Informational Guide* (Rodegerdts et al., 2010) refers to the access management in the context of roundabouts.

NCHRP Report 672. Roundabouts, An Informational Guide (Rodegerdts et al., 2010). This informational guide on roundabouts includes access management information in the context of roundabouts under the general characteristics of roundabouts as part of the geometric process (Sections

2.2.5 p. 2.9 and 6.11, pp. 6-95 to 6-98). The information on access management builds upon the information provided in the Kansas Roundabouts Guide (Kittelson & Associates, Inc. and TranSystem Corporation, 2003). An important fact mentioned in this document is that “Most of the principles used for access management at conventional intersections can also be applied at roundabouts” (p.2-9). The report also states that “Access management at roundabouts follows many of the principles used for access management at conventional intersections” (p. 6-95). However, roundabouts are different from other types of intersections because they can provide U-turn opportunities allowing for a reduction of full access points along a roadway segment and therefore enhance access management.

Public and private property access within the vicinity of a roundabout should be carefully evaluated and the cases of “access into the roundabout itself” and “access near the roundabout” should be taken into account. Driveways located in the roundabout should be avoided because they can create conflicts in the circulatory roadway, including acceleration and deceleration, even though there are cases where direct access is given to residences. In order to have a driveway taking direct access to the circulatory roadway of a roundabout, no alternative access points should be available, low traffic volumes should be present at the driveway, a low number of unfamiliar drivers should use the roundabout, the driveway should be properly designed to allow vehicles to turn around and exit facing forward, and the roundabout should provide adequate sight distance and SSD. Where driveways are located in or near a roundabout, the design should give a clear visual indication that private driveways are adjacent to the roundabout and are not for public use.

The ability to provide public and private access points near a roundabout is influenced by a number of factors such as the capacity of the minor movements at the access points, the need to provide left-turn storage on the major street to serve the access point, the available space between the access point and the roundabout, and the sight distance needs. Figure 29 shows the typical dimensions for left-turn access near roundabouts. They include a minimum of 50 ft. to clear the median, a minimum of 75 ft. to allow for the left turning movement, and 90 ft. for decelerating (or accelerating) maneuvering and queuing in the left turn lane. .

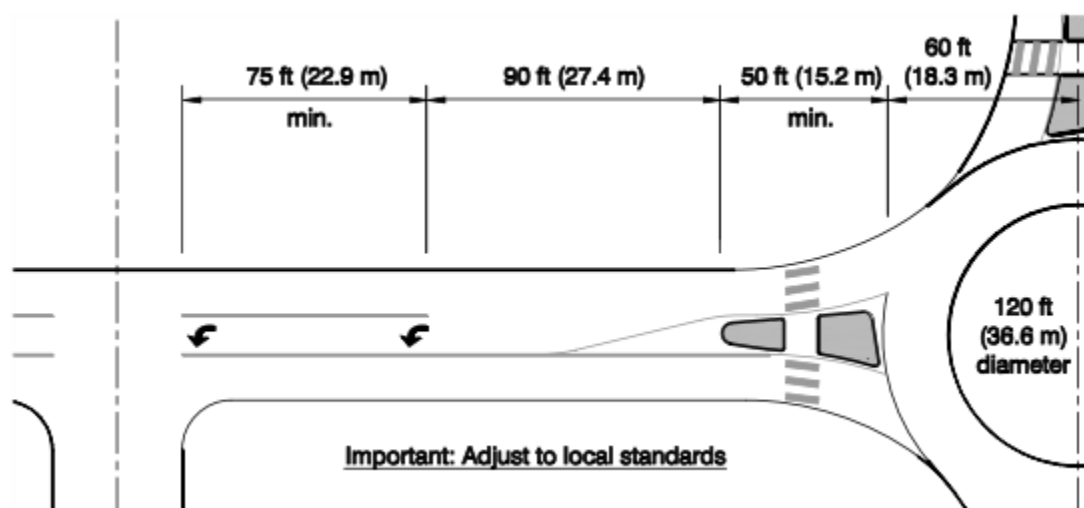

Figure 29. Typical Dimensions for Left-turn Access near Roundabouts (Rodegerdts et al., 2010, p.6-98)

4.4 States’ Guidance on Access Management in the Context of Roundabouts

A small number of states refer to access management within the context of roundabouts. Some include such information in their roundabouts manuals and some in their access management manuals. From the seven

states that refer to access management in the context of roundabouts, only three of them substantially supplement information from the national guidance. These states include Kansas, Virginia, and Wisconsin. Additional information is provided about access management in California, Iowa, Michigan, and Pennsylvania access management guidance documents. State information is described for these seven states in the following section.

California. The Caltrans Roundabout Geometric Design Guidance (Caltrans, 2007) mentions that attention should be paid to providing access to pedestrians with visual impairments at roundabouts and, more particularly, at multilane roundabouts, as often, conventional design may not be sufficient. Also, Caltrans Division of Design and Office of Geometric Design Standards developed the Design Information Bulletin Number 80-01 as a supplement to the FHWA Report, *Roundabouts: An Informational Guide*. One of the additions regarding access management was accommodating bicyclists on the state highway system by providing ramps to enter the shared-use path for those who do not want to use the circulatory roadway. Another addition was the recommendation of crosswalks with “zebra” longitudinal lines, transverse lines, and use of detectable warning surfaces at all pedestrian crossings.

Iowa. Iowa DOT has sponsored its state university to develop *Planning-Level Guidelines for Modern Roundabouts* (Hallmark and Isebrands, 2008). That guidebook states that access to pedestrians is only allowed across the approach legs, and parking is not allowed within the circulating roadway, and that roundabouts can be considered in cases where there is need for U-turns and where right-in-right-out restrictions exist. A note in the document mentions that “[a]ccess management principles align with how roundabouts function and operate. Corridors that are hampered with numerous accesses, especially those to businesses, can benefit from roundabouts. Roundabouts facilitate the use of U-turns at intersections and allow for right turns into driveways and parking lots rather than left turns across traffic. The impacts of right-in-right-out restrictions and closed medians become reduced when roundabouts provide a natural U-turn at an adjacent intersection” (Hallmark and Isebrands, 2008, p. 17).

Kansas. Access management in the context of roundabouts is referred to in two Kansas DOT (KsDOT) documents: *Kansas Roundabout Guide: A Supplement to FHWA’s Roundabouts* (Kittelson & Associates and Transystem Corporation, 2003); and *KsDOT Access Management Policy* (KsDOT, 2013). The first document includes all the information on access management that NCHRP Report 672, *Roundabouts, An Informational Guide* adapted. This information is described above, in Section 4.3. In the second document, the access spacing from roundabout intersections is discussed. KsDOT’s roundabout access spacing to an access point on the highway is consistent with KsDOT’s unsignalized access spacing. That spacing should be measured from the end of the splitter island, leaving the roundabout as shown in Figure 30. The appropriate corner clearance is then provided between the end of the splitter island and the first access point along the local intersecting roadway.



Figure 30. Measured Distance from Splitter Island to First Access Point (KsDOT, 2013, p. 4-26)

Michigan. MDOT has two guidebooks that focus on access management within and near roundabouts. In *Evaluating the Performance and Safety Effectiveness of Roundabouts* (Bagdade et al., 2011) the research report mentions that additional provisions such as pedestrian hybrid beacons, flashing pedestrian beacons, and raised sidewalks may be included in two-lane roundabouts to enhance the safety of visually impaired pedestrians. The *Access Management Guidebook* states (MDOT, 2008) that “Driveways need to be located a safe distance from a roundabout with adequate signage. Driveways should not be located within a roundabout” (MDOT, 2008, p. 3-29).

Pennsylvania. Pennsylvania’s *Guide to Roundabouts* notes (PennDOT, 2007) that accessible pedestrian crossing should be provided at all roundabouts except rural roundabouts with nonexistent pedestrian activity. Pedestrian crossings should be located back from the circulatory roadway and the splitter island should be cut to allow pedestrians, wheelchairs, strollers, and bicycles to pass through. Bicycles should be given the option of traveling through the roundabout either as a vehicle or as a pedestrian, based on the bicyclist’s level of comfort. In the case where bicyclists choose to share the sidewalk and travel as pedestrians, they are required to dismount their bike and walk with it. PennDOT’s *Guide to Roundabouts* (PennDOT, 2007) was developed based on KsDOT’s *Roundabout Guide*, (Kittelsohn & Associates and Transystem Corporation, 2003) and it includes exactly the same information on access management in the context of roundabouts as the KsDOT’s *Roundabout Guide*.

Virginia. *Access Management Design Standards for Entrances and Intersection* (Virginia DOT, 2007, revised 2011), includes information about roundabouts in Appendix F, Section 2 (Virginia DOT, 2007). In that guide, roundabouts are separated from signalized and unsignalized intersections/crossovers by the unsignalized intersection spacing standard (e.g., second column in Figure 31). They are also separated from other roundabouts by the partial access entrance spacing standard (i.e., the last column in Figure 31); partial access entrance refers to roadways that have access management techniques to prevent left-turn ingress and egress movements and facilitate right-in and right-out movements. The spacing is measured from the outer edge of the nearest inscribed diameter, not the centerline. The spacing standards used are shown in Figure 31. In addition, design guidelines regarding pedestrian and bicycle treatments should follow NCHRP Report 672, *Roundabouts, An Informational Guide*.

Highway Functional Classification	Legal Speed Limit (mph) ^①	Minimum Centerline to Centerline Spacing (Distance) in Feet			
		Spacing from Signalized Intersections to Other Signalized Intersections ^②	Spacing from Unsignalized Intersections/Crossover to Signalized or Unsignalized Intersections/Crossovers ^③	Spacing from Full Access Entrances to Other Full Access Entrances and Any Intersection on Highways Without Restrictive Medians ^④	Spacing from Partial Access One or Two Way Entrances to Any Type of Entrance, Intersection or Crossover ^⑤
Principal Arterial	≤ 30 mph	1,050	880	440	250
	35 to 45 mph	1,320	1,050	565	305
	≥ 50 mph	2,640	1,320	750	495
Minor Arterial	≤ 30 mph	880	660	355	200
	35 to 45 mph	1,050	660	470	250
	≥ 50 mph	1,320	1,050	555	425
Collector	≤ 30 mph	660	440	225	200
	35 to 45 mph	660	440	335	250
	≥ 50 mph	1,050	660	445	360
Local Street ^⑥	Commercial entrance spacing: See Figure 4-11.				

Figure 31. Minimum Spacing Standards for Commercial Entrances, Intersections, and Crossovers (VDOT, 2007, p. F-23)

Wisconsin. Wisconsin's *Roundabout Guide* (WisDOT, 2011) includes information about access control in Chapter 11, Section 26. That chapter was recently (March 4, 2013) updated. Based on that guide, roundabouts would facilitate left turns and U-turns to access properties on the opposite side of the highway. Also, the pedestrian crossing location should be set back from the yield line, typically one car length. In addition, connecting two roundabouts with a raised median precludes lefts in/out from the side street or business access to protect main-line capacity, although major commercial driveways may be allowed as one leg of the roundabout. Minor commercial and residential driveways are not recommended along the circulating roadway except if they are designed as a leg of the roundabout, and driveways should be set back to prevent interference with pedestrian movements in crosswalks (WisDOT, 2011). When it comes to access management, the guide states:

Retrofit of suburban commercial strip development to accomplish access management objectives of minimizing conflicts can be a particularly good application for roundabouts. Raised medians are often designed for State arterials to minimize left turn conflicts; and roundabouts accommodate U-turns. Left-turn exits from driveways onto an arterial that may currently experience long delays and require two-stage left-turn movements could be replaced with a simpler right turn, followed by a U-turn at the next roundabout. Again, a package of improvements with driveway consolidation, reverse frontage, and interconnected parking lots, should be planned and designed with close local collaboration. Also, a roundabout can provide easy access to corner properties from all directions. (WisDOT, 2011).

4.5 Roundabout Location Guidelines

Kansas DOT mentioned sites where roundabouts bring advantages, and where the roundabout should be built cautiously. Intersections that may have benefits in converting into roundabouts are the ones with (Kittelson & Associates and TranSystem Corporation, 2003, p.38):

- Historical safety problems;
- Relatively balanced traffic volumes;
- High percentage of turning movements;
- High volumes at peak hours but relatively low volumes at non-peak hours;
- Existing two-way stop-controlled that have high side-street delay;
- The requirements to accommodate U-turn;
- A role as gateway or entry point to campus, neighborhood, commercial development, or urban area;
- Intersections where a community enhancement may be desirable;
- Intersections where traffic calming is a desired outcome of the project;
- Intersections where growth is expected to be high and future traffic patterns are uncertain;
- Locations where the speed environment of the road changes;
- Locations with a need to provide a transition between land use environments; and
- Roads with a historical problem of excessive speeds.

However, the locations of roundabout that have the following conditions should receive extra attention:

- Intersection in close proximity to a signalized intersection where queues may spill back into the roundabout;
- Intersections located within a coordinated arterial signal system;
- Intersections with a heavy flow of through traffic on the major road opposed by relatively light traffic on the minor street;
- Intersections with physical or geometric complications;
- Locations with steep grades and unfavorable topography that may limit visibility and complicate construction;
- Intersections with heavy bicycle volumes; and
- Intersections with heavy pedestrian volumes.

Closely Spaced Roundabout. Wisconsin DOT considers roundabouts to be closely spaced when the distance is less than 1,000 ft. from the center of each roundabout.

4.6 Geometry Design Guidelines

This review highlights geometric aspects that differ among states' guidance and NCHRP Report 672, *Roundabouts, An Informational Guide* or other listed national documents.

WisDOT mentioned the effects of design elements on Safety and Operations and outlines trade-off effects on the relationship between safety and capacity as shown in Figure 32.

Element	Safety	Capacity	Speed
Wider entry (gore area)	Less safe	Increase	Increase
Wider Circulatory lanes	Less safe	Better	Increase
Larger entry radius	Less safe	Better	Increase
Larger inscriber circle diameter	Less safe	Better	Increase
Larger angle between approach legs	Safer	Decrease	Neutral
Smaller entry angle (phi)	Poorer sight	Better	Increase
Longer flare length	Neutral	Better	Neutral

Figure 32. The Effect of Design Elements (WisDOT, 2011, p.38)

Speed. Kansas DOT provides the roundabout design speed based on site categories: mini-roundabout, urban compact, urban single-lane, rural single-lane, urban double-lane, and rural double-lane roundabout. Table 13 shows the roundabout design speed that Kansas DOT applied.

Table 13. Roundabout Design Speed

Site Category	Maximum Entry (R1) Design Speed
Mini Roundabout	20 mi/h (32 km/h)
Urban Compact Roundabout	20 mi/h (32 km/h)
Urban Single-Lane Roundabout	25 mi/h (40 km/h)
Rural Single-Lane Roundabout	25 mi/h (40 km/h)
Urban Double-lane Roundabout	25 mi/h (40 km/h)
Rural Double-Lane Roundabout	30 mi/h (48 km/h)

Source: Kansas DOT, p.67

Lane numbers and arrangements. In determining these, Caltrans used capacity models taking critical headway and follow-up headway specifically as follows: single-lane roundabout (4.8 s and 2.5 s, respectively); multilane roundabouts, left lane (4.7 s and 2.2 s, respectively); and multilane roundabouts, right lane (4.4 s and 2.2 s, respectively). Headway values for WisDOT are presented in Table 14.

Table 14. Recommended Headway Values (WisDOT, 2011, p31)

Number of Circulating (Conflicting) Lanes	Critical Headway, t_c	Follow-up Headway, t_f	Parameter A	Parameter B
One	4.2* sec	2.8 sec	1286	0.000778
Two or Three	4.0 sec	2.8 sec	1286	0.000722

* Based on NCHRP 572, not Wisconsin Research

Spacing. Caltrans developed a standard for spacing entries and exits to minimize exit-circulating conflicts. The spacing is considered important for multilane, more than for four-leg and skewed-leg roundabouts. As a response to the circulating-exiting path conflict (Figure 33), Caltrans offered two solutions, as seen in Figure 34.

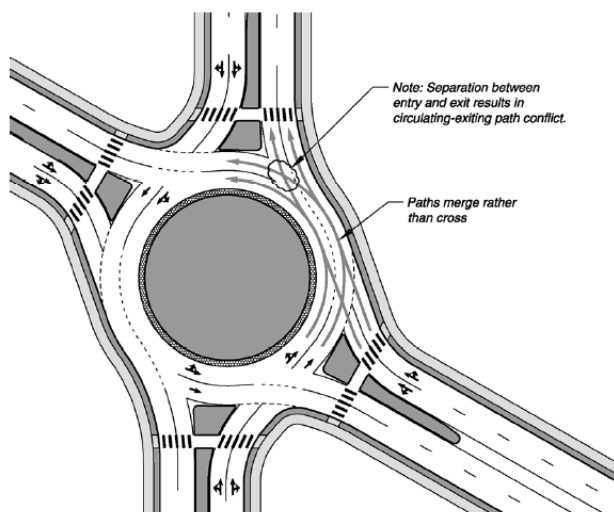

Figure 33. Example Solution Design with Circulating-Exiting Path Conflict (Caltrans, 2007, p.62)

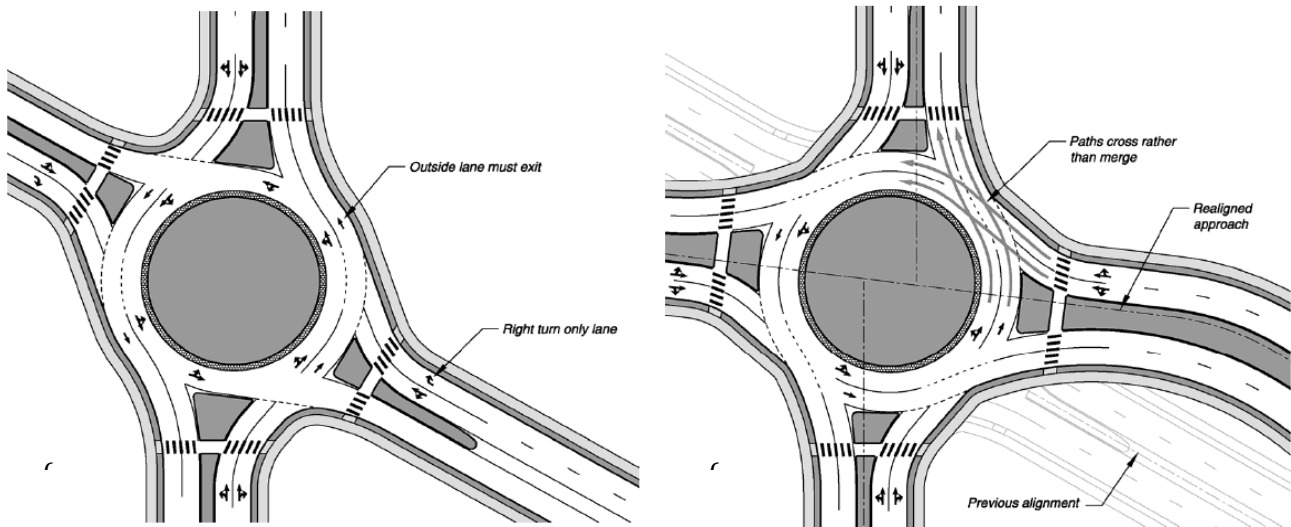

Figure 34. Solution Options for Circulating-Exiting Path Conflict: (i) Modify Lane Configuration, and (ii) Realign Approaches (Caltrans, 2007, p.63-64)

Sight Distance. AzDOT requires that a roundabout design meet two sight distance standards: SSD and ISD. The ISD includes the approach and departure sight triangles. Caltrans focuses on ensuring proper sight to the left. For sight distance calculations, “the critical headway of 5.9 sec. is recommended instead of the 6.5 sec. presented in *Roundabouts: An Informational Guide* (Robinson et al., 2000). This methodology should be considered interim until a study on roundabout ISD is completed” (p. viii). For the angle of visibility, Caltrans compared AASHTO, *The Caltrans Highway Design Manual*, and *FHWA Highway Design Handbook for Older Drivers and Pedestrians*, which had minimum angles of 60 degrees, 75 degrees at grade, and 75 degrees, respectively. Figure 35 shows an example of an intersection that has a problem with the angle of visibility. Kansas DOT refers to the FHWA Publication (Robinson et al., 2000) for the ISD and AASHTO fourth edition. The calculation assumed a critical gap of 6.5 s. and of 4.6 s. if constraints from topographic features or building exist (similar to the lower bound of the HCM 2000 (TRB, 2000)).

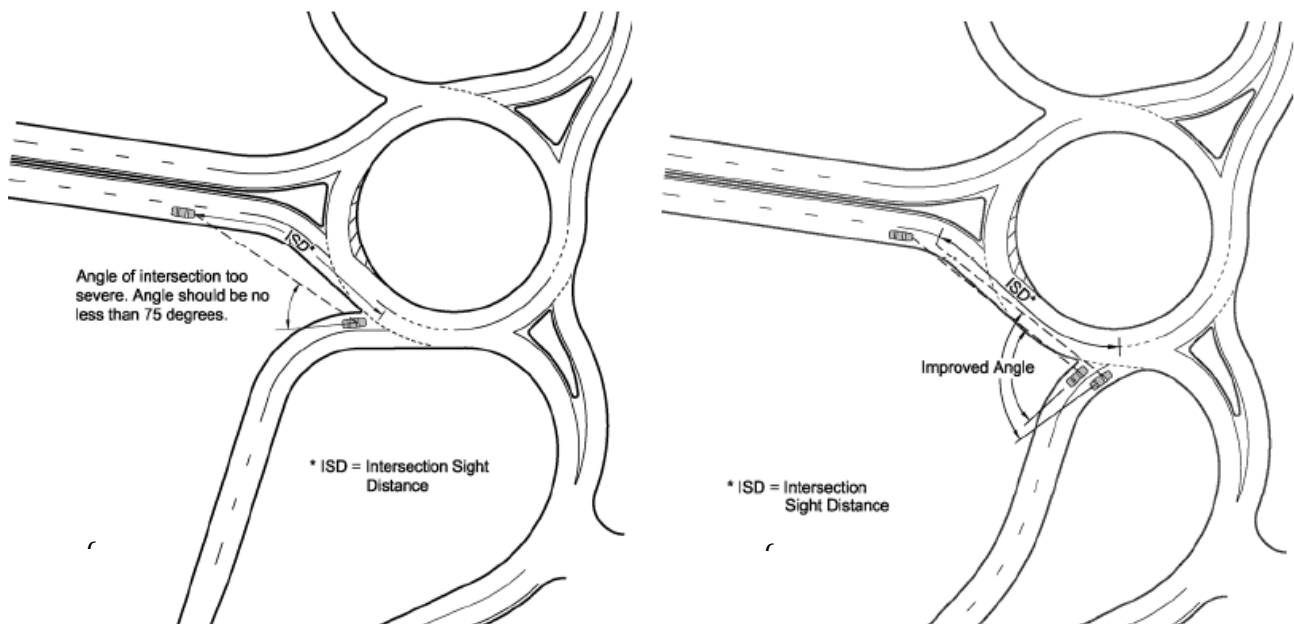

Figure 35. Angle of Visibility: (i) the Angle is Too Severe (ii) Realigned Ramp Terminal Approach to Have Better Angle of Visibility (Caltrans, 2007, p. 65)

Kansas DOT decides the design speed from the calculation of SSD and ISD. First, SSD includes the requirements of approach sight distance, sight distance on the circulatory roadway, and sight distance to crosswalk on the immediate downstream exit. Also, Kansas DOT mentions that sight distance for landscaping materials have limitation of 2 ft. or 600 mm. height.

WisDOT specifies the guidance for closely-spaced multiple roundabouts. In the document, WisDOT uses the minimum visibility distance shown in Table 15.

Table 15. Wisconsin DOT Minimum Visibility Distance

Posted or 85 th Percentile Speed	Minimum Visibility Distance
25 mph	280 ft
30 mph	335 ft
35 mph	390 ft
40 mph	445 ft
45 mph	500 ft
50 mph	555 ft
55 mph	610 ft

* Minimum Visibility Distances are from Section 2C.36 of the Wisconsin Supplement to the 2009 MUTCD

Inscribed Circle Diameter (ICD). The Caltrans compared ICD for FHWA standard, Kansas, Arizona, and Wisconsin depending on the roundabout categories. Table 16 displays the ICD for these states.

Table 16. Typical Inscribed Circle Diameter Ranges (Caltrans, 2007, p. 67)

Roundabout Category*	Inscribed Circle Diameter Range (ft)		
	FHWA	Kansas/Arizona	Wisconsin
Mini-Roundabout	45-80	50-90	N/A
Urban Compact	80-100	90-120	N/A
Urban Single Lane	100-130	120-150	100-160
Urban Double Lane	150-180	150-220	150-200
Urban Multilane (3 or 4-lane entry)	N/A	N/A	180-330
Rural Single Lane	115-130	130-200	115-180
Rural Double Lane	180-200	175-250	180-230
Rural Multilane (3 lane entry)	N/A	N/A	180-330

*Note: Roundabouts are categorized based on the size of the ICD, the number of circulating lanes, and urban/rural environment. Refer to the FHWA Guide for further details.

To update those standards, Caltrans incorporates lane numbers and arrangements, design vehicles, number of legs, and approach alignment on their standards. Table 17 gives the common ranges of inscribed circle diameters based on the aforementioned factors.

Table 17. Common Ranges of Inscribed Circle Diameters (Caltrans, 2007, p.68)

Scenario	Common Range of Inscribed Circle Diameters*
Single-lane roundabout, 3 to 4 legs, 90-degree angles, WB-50 design vehicle	115**-130 ft
Single-lane roundabout, 3 to 4 legs, 90-degree angles, STAA/WB-67 design vehicle	130-150 ft
Single-lane roundabout, 5 to 6 legs, WB-50 design vehicle	130-180 ft
Single-lane roundabout, 5 to 6 legs, STAA/WB-67 design vehicle	150-200 ft
Double-lane roundabout, 3 to 4 legs	150-220 ft
Double-lane roundabout, 5 to 6 legs	180-240 ft
Triple-lane roundabout, 4 legs	180-330 ft

* Ranges are representative but not inclusive of all possible values

** Smaller diameters are possible but may require trucks to circulate at very low speeds

Source: Adapted from FHWA (1), Kansas (2), and Wisconsin (9) roundabout guidance, as well as the authors' experience and judgment.

Geometric design for users. The needs of various users are considered in the state guidelines. For example: design vehicle, pedestrians, bicyclists, and older drivers. First, AzDOT applied special considerations to roundabouts by adding a truck apron. Caltrans uses the design vehicle as one of geometric design consideration, covering car swept path for different types of design vehicles. The guidelines comparison for design vehicles for multilane roundabouts is presented in **Table 18**. In addition, Caltrans provides design recommendations for pedestrians, including crossing treatments and methodologies as in TCRP Report 112 and NCHRP Report 562.

Table 18. The Guidelines Comparison for Design Vehicles on Multi-lane Roundabouts (Caltrans, 2007).

Agency	Source	Inscribed Circle Diameter	Circulatory Roadway Width for WB-67 Design Vehicle	Recommended Pair of Side-by-Side Vehicles for Design
FHWA	<i>Roundabouts: An Informational Guide (1)</i>	180 feet	30 feet (minimum)	<ul style="list-style-type: none"> • Depending on site conditions: • Two passenger cars OR • Passenger car + single-unit truck OR • Semi-trailer + passenger car OR • Semi-trailer + single-unit truck
Kansas DOT	<i>Kansas Roundabout Guide (2)</i>	180 feet	30 feet (minimum)	<ul style="list-style-type: none"> • Depending on site conditions: • Passenger car + bus OR • Passenger car + single-unit truck OR • Semi-trailer + passenger car
Washington State DOT	<i>WSDOT Design Manual (46)</i>	N/A	<ul style="list-style-type: none"> • Maintain 2-ft clearance to any curb face • Minimum circulatory with equal to or slightly wider (120%) than maximum entry width. 	N/A
New York State DOT	<i>Roundabouts: Interim Requirements and Guidance (45)</i>	N/A	Maintain 3-ft horizontal clearance	N/A
Missouri DOT	<i>Project Development Manual</i>	N/A	N/A	Two trucks (type and size not specified)
Wisconsin DOT	<i>Facilities Development Manual (9)</i>	N/A	N/A	N/A
Pennsylvania DOT	<i>Guide to Roundabouts (44)</i>	N/A	N/A	N/A
Florida DOT	<i>Florida Roundabout Guide (43)</i>	N/A	Will not normally exceed 1.2 times the maximum entry width	N/A
Oregon DOT	<i>Modern Roundabouts for Oregon (41)</i>	N/A	Will not normally exceed 1.2 times the maximum entry width	N/A
Austroroads	<i>Design Guide For Roundabouts (14)</i>	180 feet	32 feet	• 1 articulated vehicle + 1 car

WisDOT has complete guidance for design vehicles on two-lane roundabouts. The guidebook explores three design categories for legal truck access (WisDOT, 2013, p.47). The first case is when roundabouts allow trucks to encroach into adjacent lanes as they approach, enter, circulate, and exit the intersection. The second case is when roundabouts allow trucks in-lane as they approach and enter the roundabout, but may require trucks to encroach into adjacent lanes as they circulate and exit the intersection. The third case is when roundabouts accommodate trucks in-lane as they approach and traverse the entire intersection.

Besides design vehicles, the states' roundabout guides address concerns about pedestrians and bicycle accommodations. Kansas DOT focuses on geometric elements for pedestrian crossings, such as location, *Roundabouts and Access Management*

crossing alignment and splitter islands. In addition, the document of the Kansas DOT pays attention to visually impaired pedestrians, ways to avoid having the pedestrian cross the central island, and to providing multi-modal sidewalks. Detailed designs for pedestrians include the following aspects: (1) the pedestrian crossing is expected to maintain one vehicle length or about 25 ft. away from the roundabout entrance; (2) curb ramps and pedestrian crossings should be available and be straight and continuously aligned on the roundabout; (3) way-finding and gap detection may need to be considered for visually impaired pedestrians; and (4) the distance of sidewalks from the circulatory roadway should be at least 2 ft., although the recommended distance is 5 ft. Furthermore, it is recommended that the bike lane merge with sidewalks at least 100 ft. (30 m) upstream of the entrance line.

To accommodate pedestrians and bicyclists, WisDOT describes design guidance for pedestrian facilities, bicycle markings, and bike ramp entrances and exits (WisDOT, 2013, p.18). The pedestrian facilities include the sidewalks, shared-use paths, and roundabout side paths. WisDOT found that roundabouts, when compared to other type of intersections, do have an advantage when pedestrian and bicyclist safety is concerned (WisDOT, 2013, p.18). This is because the low operating speeds through roundabouts and there are less conflict point between pedestrians and vehicles. For pedestrian crossing at roundabout, it is important to choose a crosswalk location that can balance pedestrian safety, their convenience and the operation of roundabouts. For bicyclists, the biggest challenge is accommodate turning movement at roundabouts. WisDOT recommended using pedestrian-bicycle path separate from the circulatory roadway to accommodate bicyclist at roundabouts (WisDOT, 2013, p.19).

Chapter Five: Safety Analysis

This chapter includes a safety analysis that investigates potential safety concerns associated with roundabouts in commercial areas in Florida. As identified in Chapter Three, the potential safety concerns include: (1) impact of driveway corner clearances on roundabout safety; (2) safety impact of median openings in the vicinity of roundabouts; (3) safety at roundabouts that provide direct access to activity centers; and (4) safety of vulnerable road users including pedestrians and bicyclists.

General statistics that give an overview of the crashes that occurred in the vicinity of all identified roundabouts in Florida are provided first. An analysis based on crash data and detailed review of police reports is then conducted to address each of the previously listed safety concerns. The chapter concludes with a summary of findings and a list of specific recommendations.

5.1 Overall Crash Statistics

As indicated in Chapter Three, a total of 1,882 crashes were found to occur during 2007-2011 within 500 ft. of 283 roundabouts. This section provides an overall summary of these crashes in the following order: (1) area type; (2) crash type; (3) crash severity, and (4) number of vehicles involved in a crash.

5.1.1 Area Type

The 283 roundabouts were categorized into two different area types: commercial and residential. Commercial roundabouts are those that are located in commercial areas that serve mostly commercial traffic. Similarly, residential roundabouts are those that are located in mainly residential areas. Mixed-use areas, which include both commercial and residential, are included with commercial roundabouts because of the traffic associated with the commercial land use. Table 19 gives the total number of roundabouts and crashes in each area type. Table 19 also provides the crash statistics by area type. Overall, each roundabout experienced an average of 6.65 crashes during the five-year analysis period; with commercial roundabouts experiencing 8.10 crashes per roundabout while residential roundabouts experienced 5.40 crashes per roundabout. The table also shows a higher standard deviation for the numbers of crashes for roundabouts in commercial areas, indicating that the crash frequencies vary more among the commercial roundabouts than the residential roundabouts.

Table 19. Statistics by Area Type

Area Type	Total Crashes in Five Years (a)	Number of Roundabouts (b)	Crashes per Roundabout in Five Years (a/b)	Standard Deviation
Commercial	1,061	131	8.10	13.65
Residential	821	152	5.40	9.20
Total	1,882	283	6.65	11.53

5.1.2 Crash Type

Table 20 gives the summary of crash statistics by crash type and area type. It also provides the percent of nighttime crashes by crash type. Figure 36 provides the percentage of total crashes and nighttime crashes by crash type. Collision with a fixed object was the most frequent crash type. About a quarter (24.7%) of all crashes that occurred in the vicinity of roundabouts resulted from vehicles hitting a fixed object, mostly,

the roundabout center island. Also, about two-thirds (62.9%) of these crashes (i.e., collision with a fixed object) occurred at night. Next to the collision with a fixed object, angle and rear-end crashes were most common, accounting for 21% and 18.5% of total crashes, respectively. Additionally, the distribution of crash types was found to be similar in commercial and residential areas.

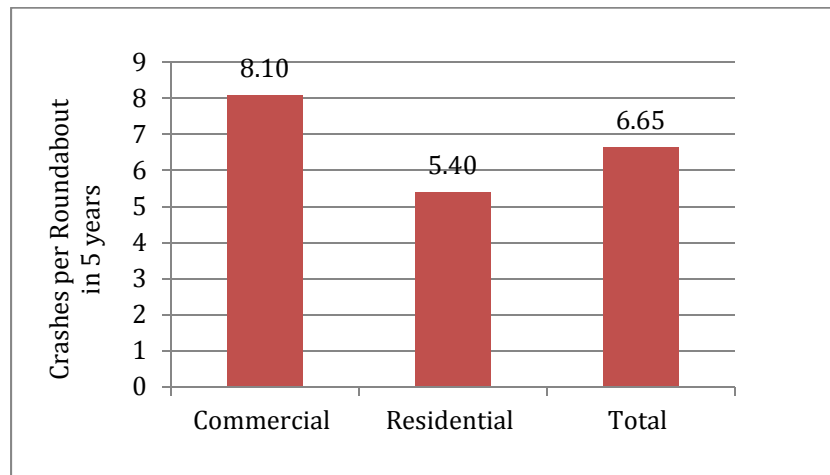

Figure 36. Statistics by Area Type

Table 20. Statistics by Crash Type

Crash Type ¹	Commercial Area			Residential Area			Total Crashes		
	No. (a)	Percent of Total Crashes (a/1,061)	Percent of Nighttime Crashes	No. (c)	Percent of Total Crashes (c/821)	Percent of Nighttime Crashes	No. (d)	Percent of Total Crashes (d/1,882)	Percent of Nighttime Crashes
Rear-end	188	17.7%	19.1%	161	19.6%	20.0%	349	18.5%	19.5%
Head-on	20	1.9%	40.0%	15	1.8%	53.3%	35	1.9%	45.7%
Angle	217	20.5%	18.9%	179	21.8%	26.3%	396	21.0%	22.2%
Left-turn	29	2.7%	13.8%	12	1.5%	33.3%	41	2.2%	19.5%
Right-turn	37	3.5%	24.3%	14	1.7%	21.4%	51	2.7%	23.5%
Side-swipe	55	5.2%	23.6%	41	5.0%	19.5%	96	5.1%	21.9%
Backed Into	16	1.5%	31.3%	15	1.8%	26.7%	31	1.6%	29.0%
Collision with Parked Car	27	2.5%	29.6%	18	2.2%	50.0%	45	2.4%	37.8%
Collision with Motor Vehicle	48	4.5%	20.8%	32	3.9%	34.4%	80	4.3%	26.3%
Collision with Pedestrian	14	1.3%	40.0%	4	0.5%	25.0%	18	1.0%	36.8%
Collision with Bicycle	35	3.3%	8.6%	16	1.9%	18.8%	51	2.7%	11.8%
Collision with Fixed Object	250	23.6%	63.6%	215	26.2%	62.1%	465	24.7%	62.9%
All Other	125	11.8%	47.2%	99	12.1%	43.6%	224	11.9%	45.7%
Total	1,061	100.0%	34.0%	821	100.0%	37.4%	1,882	100.0%	35.5%

¹ These statistics are based on the first harmful event (FHE) coded in the police reports. Note that these numbers are different from those provided later in the chapter since detailed analyses were based on the review of police reports.

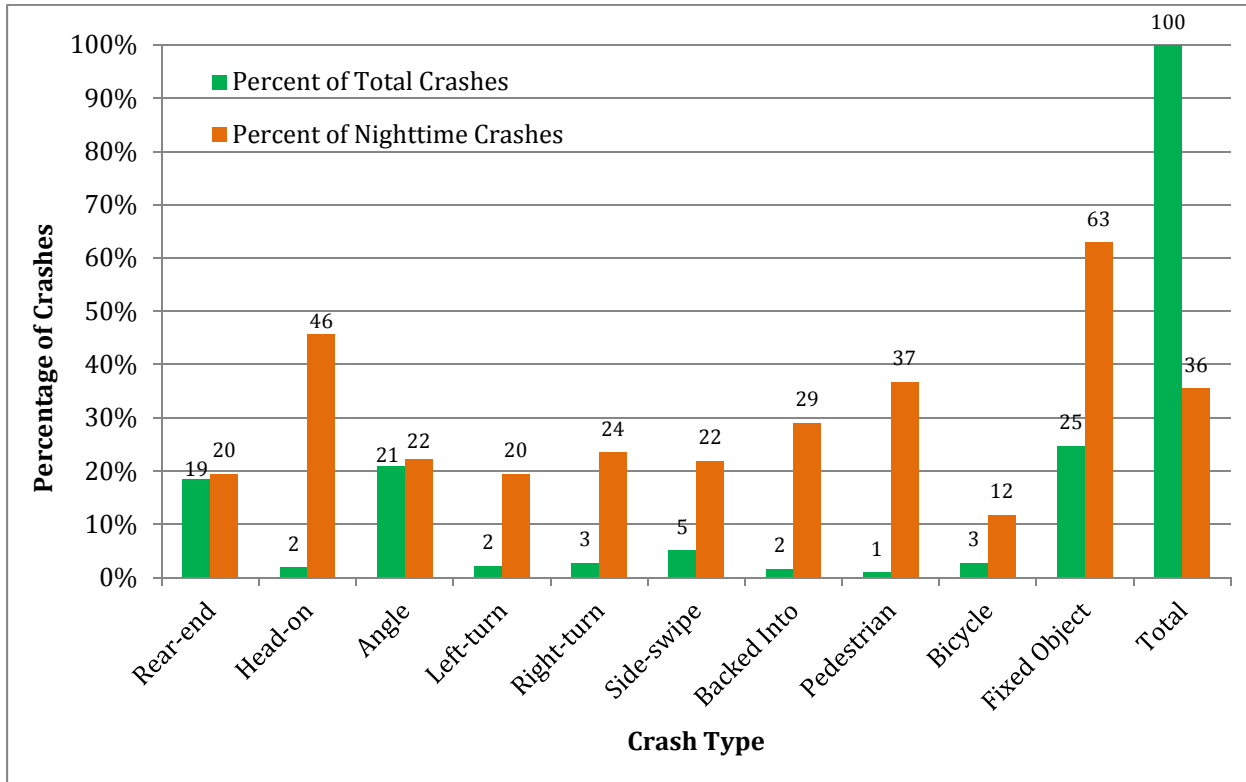

Figure 37. Total and Nighttime Crash Statistics by Crash Type

5.1.3 Crash Severity

Figure 38 provides the number and percentage of crashes by crash severity. Table 21 summarizes the crashes by crash severity and area type. A majority of crashes (i.e., over 60%) that occurred at roundabouts resulted in property damage only (PDO). Severe injury crashes (i.e., fatal and incapacitating injury crashes) accounted for less than 5% of the total crashes. Severe injury crash frequency per roundabout was slightly higher at commercial roundabouts (5.4%) compared to residential roundabouts (4.4%). However, the overall distributions were similar. Also, crash severity of several crashes was unknown; most of which were a result of hit-and-run (i.e., the driver fled the crash site prior to the arrival of the law enforcement officials).

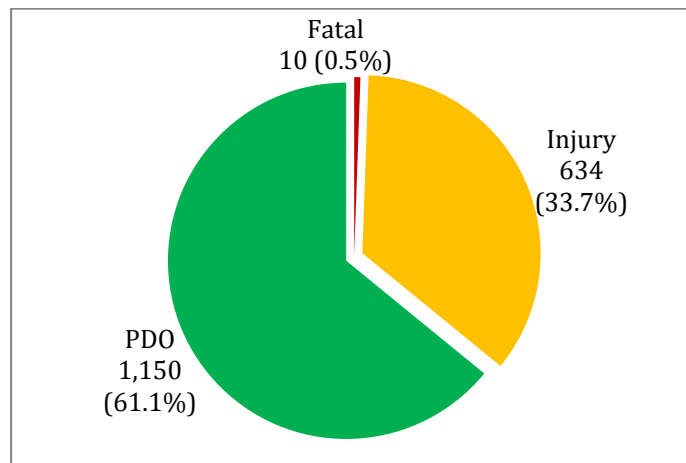

Figure 38. Statistics by Crash Severity

Table 21. Statistics by Crash Severity and Area Type

Crash Severity	Commercial Area		Residential Area		Total Crashes	
	No. (a)	Percent (a/1,061)	No. (c)	Percent (c/821)	No. (d)	Percent (d/1,882)
Fatal Injury	4	0.4%	6	0.7%	10	0.5%
Incapacitating Injury	53	5.0%	30	3.7%	83	4.4%
Non-Incapacitating Injury	152	14.3%	105	12.8%	257	13.7%
Possible Injury	164	15.5%	130	15.8%	294	15.6%
Property Damage Only	642	60.5%	508	61.9%	1,150	61.1%
Unknown ¹	46	4.3%	42	5.1%	88	4.7%
Total	1,061	100.0%	821	100.0%	1,882	100.0%

¹ The severity of a crash is unknown when the driver fled the crash site prior to the arrival of law enforcement officials.

5.1.4 Number of Vehicles Involved

Table 22 provides summary statistics of single-vehicle and multi-vehicle crashes by area type. Overall, about one-third of the total crashes were single-vehicle crashes, while the rest involved multiple vehicles. The table shows that the proportion of single- and multi-vehicle crashes was found to be consistent across area types.

Table 22. Statistics of Single-vehicle and Multi-vehicle Crashes by Area Type

Crash Type	Commercial Area		Residential Area		Total Crashes	
	No. (a)	Percent (a/1,061)	No. (c)	Percent (c/821)	No. (d)	Percent (d/1,882)
Single-vehicle	342	32.2%	292	35.6%	634	33.7%
Multi-vehicle	719	67.8%	529	64.4%	1,248	66.3%
Total	1,061	100.0%	821	100.0%	1,882	100.0%

Table 23 gives the summary of single-vehicle and multi-vehicle crash statistics by crash severity. Single-vehicle crashes (8.9%) had a higher proportion of severe injuries than multi-vehicle crashes (2.9%). Also, a greater percentage of single-vehicle crashes resulted in injuries compared to multi-vehicle crashes; 68.8% of multi-vehicle crashes resulted in PDO crashes, while only 45.9% of single-vehicle crashes were PDOs. Of the six fatal single-vehicle crashes, four involved motorcycles, and in all these four crashes, the motorcyclist was found to be at fault. Another fatal crash involved a vehicle and an intoxicated pedestrian who ran into the path of the vehicle. Two of the four fatal multi-vehicle crashes involved a golf cart.

5.2 Impact of Driveway Corner Clearances on Roundabout Safety

Driveway corner clearance is defined in the context of this study as the minimum distance between a roundabout and an adjacent driveway along each approach or departure leg. As shown in Figure 39, the upstream driveway corner clearance is measured from the first driveway upstream of the roundabout to the roundabout. Likewise, the downstream driveway corner clearance is measured from the roundabout to the first driveway downstream of the roundabout.

Table 23. Statistics of Single-vehicle and Multi-vehicle Crashes by Crash Severity

Crash Severity	Single-vehicle Crashes		Multi-vehicle Crashes		Total Crashes	
	No. (a)	Percent (a/634)	No. (b)	Percent (b/1,248)	No. (c)	Percent (c/1,882)
Fatal Injury	6	0.9%	4	0.3%	10	0.5%
Incapacitating Injury	51	8.0%	32	2.6%	83	4.4%
Non-Incapacitating Injury	128	20.2%	129	10.3%	257	13.7%
Possible Injury	91	14.4%	203	16.3%	294	15.6%
Property Damage Only	291	45.9%	859	68.8%	1,150	61.1%
Unknown Injury ¹	67	10.6%	21	1.7%	88	4.7%
Total	634	100%	1,248	100.0%	1,882	100.0%

¹ The severity of a crash is unknown when the driver fled the crash site prior to the arrival of law enforcement officials.

The focus of this section is to analyze driveway-related crashes to identify the impacts of upstream and downstream corner clearances on roundabout safety. In this analysis, a crash is considered to be driveway-related if one of the vehicles involved in the crash was entering or exiting a driveway. Particularly, crashes involving vehicles turning from a driveway onto a main street, turning from the main street onto a driveway, and backing out of a driveway onto an approach leg were identified as driveway-related crashes.

**Figure 39.** Upstream and Downstream Driveway Corner Clearances

Police reports of all the 1,882 crashes that occurred within 500 ft. of the roundabouts were reviewed to identify driveway-related crashes. Of the 1,882 crashes that occurred at roundabout legs, only 74 crashes were identified to be driveway-related. Of these 74 driveway-related crashes, 37 crashes (50%) occurred at the first driveways (i.e., the driveway that defines the corner clearance) while an equal number occurred on all other driveways.

How is safety at roundabouts affected by corner clearances? **Table 24** gives the summary crash statistics of the 37 driveway-related crashes that occurred at the first driveway. As can be inferred from the table, several approaches have shorter upstream and downstream corner clearances. Of the 37 crashes, 18 occurred at the first upstream driveway, and the remaining 19 occurred at the first downstream driveway. Six of 18 crashes (33.3%) occurred when the upstream corner clearance was less than 250 ft. On the other hand, 15 of 19 crashes (78.9%) occurred when the downstream driveway corner clearance was less than 250 ft. In terms of crash severity, of the 37 crashes, none were fatal, two resulted in incapacitating injuries, eight were non-incapacitating injury crashes, and the remaining 27 were PDOs.

Table 24. Driveway-related Crashes That Occurred within Upstream and Downstream Driveway Corner Clearances

Corner Clearance (feet)	Upstream of Roundabout			Downstream of Roundabout		
	No. of Crashes	No. of Legs	Crashes/ 100 Legs	No. of Crashes	No. of Legs	Crashes/ 100 Legs
0-49	1	29	3.4	0	36	0.0
50-99	1	70	1.4	3	64	4.7
100-149	1	55	1.8	4	61	6.6
150-199	1	53	1.9	1	44	2.3
200-249	2	41	4.9	7	28	25.0
250-299	4	35	11.4	1	40	2.5
300-349	0	18	0.0	2	18	11.1
350-399	4	18	22.2	0	22	0.0
400-449	2	13	15.4	0	16	0.0
450-500	2	17	11.8	1	12	8.3
No driveway within 500 ft.	0	141	0.0	0	149	0.0
Total	18	490^a	5.2^b	19	490^a	5.6^c

^a The 131 roundabouts have 490 legs.

^b The value does not include approaches with no driveways within 500 ft. It is calculated as $(18 \times 100) / (490 - 141)$.

^c The value does not include approaches with no driveways within 500 ft. It is calculated as $(19 \times 100) / (490 - 149)$.

These above statistics indicate that the downstream driveway corner clearance has a greater safety impact than the upstream driveway corner clearance. This result is consistent with the fact that vehicles exiting a downstream driveway experience reduced gaps due to dispersed platoons from the upstream roundabout. This is further aggravated by the fact that roundabouts also provide larger corner turning radii, allowing vehicles to turn right at a higher speed. At corners with reduced sight distance, it further reduces the time available for driveway vehicles to complete their maneuvers. Figure 40 shows an example location that has a downstream driveway corner clearance of less than 150 ft. and with a reduced sight distance due to sight obstructions.

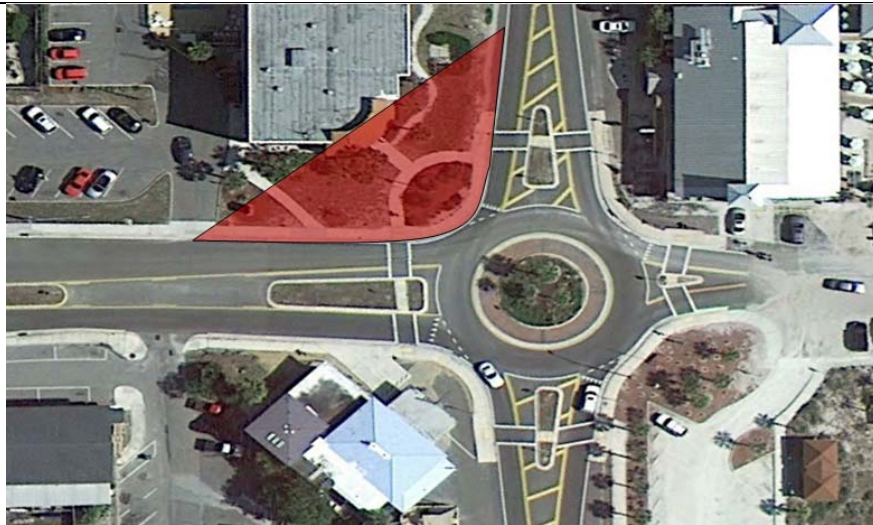

Figure 40. Roundabout on SR A1A, Nassau County, Florida with Reduced Sight Distance at Downstream Corner Clearance

5.3 Safety Impact of Median Openings in the Vicinity of Roundabouts

On corridors with raised medians, access to abutting land use is often provided through median openings. Since roundabouts disperse platoons, turning traffic at median openings in the vicinity of roundabouts experience reduced vehicle gaps, which could result in more crashes. This section examines if median openings in the vicinity of roundabouts pose a safety concern and whether closing the median openings and having vehicles make U-turns at the downstream roundabout would be beneficial.

Figure 41 (a) shows a case in which vehicles from the main street turn left at a median opening onto a driveway that is located downstream of a roundabout. Figure 41 (b) shows an alternative without the median opening and require the vehicles to make U-turns at the roundabout downstream and then make a right turn onto the driveway. Similarly, Figure 42 (a) shows a second case in which vehicles exiting from a driveway located upstream of a roundabout turn left at a median opening onto the main street. Figure 42 (b) shows an alternative without the median opening and require the vehicles to first turn right and then make a U-turn at the roundabout to complete the left turn.

In both of the above cases, the first question is whether crash statistics show significant safety problems associated with the left-turning vehicles, either onto or out of a driveway. To answer this question, crashes involving vehicles turning left at median openings (i.e., vehicles turning left from the main street onto a driveway and vehicles turning left from a driveway onto the main street) were identified by reviewing the police reports. The 131 roundabouts were found to have a total of 157 median openings within 500 ft. The crash data show that, during 2007-2011, a relatively low total of 15 crashes occurred at these 157 median openings. Of these 15 crashes, eight involved vehicles turning left from the main street onto a driveway and seven involved vehicles turning left from a driveway onto the main street. Figure 43 and Figure 44 give examples of these two scenarios, respectively. Among the crashes involving vehicles turning left from a driveway, only one crash resulted in a non-incapacitating injury and the rest were PDOs. As shown in Figure 45, the only crash involving an injury occurred when a vehicle turning left from a driveway onto the main street collided with a bicyclist. Of the eight crashes that involved vehicles turning left from the main street onto a driveway, three resulted in injuries, one was a possible injury, and the remaining four were PDOs.

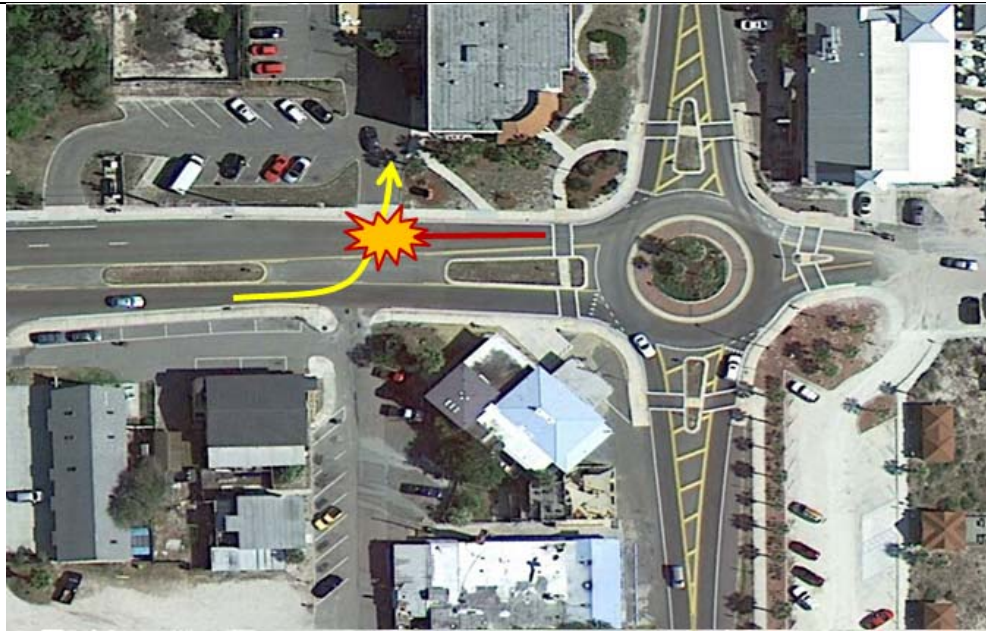

(a) Potential Safety Problem: Vehicles Turn Left from Main Street onto a Driveway at Median Opening with Reduced Gaps

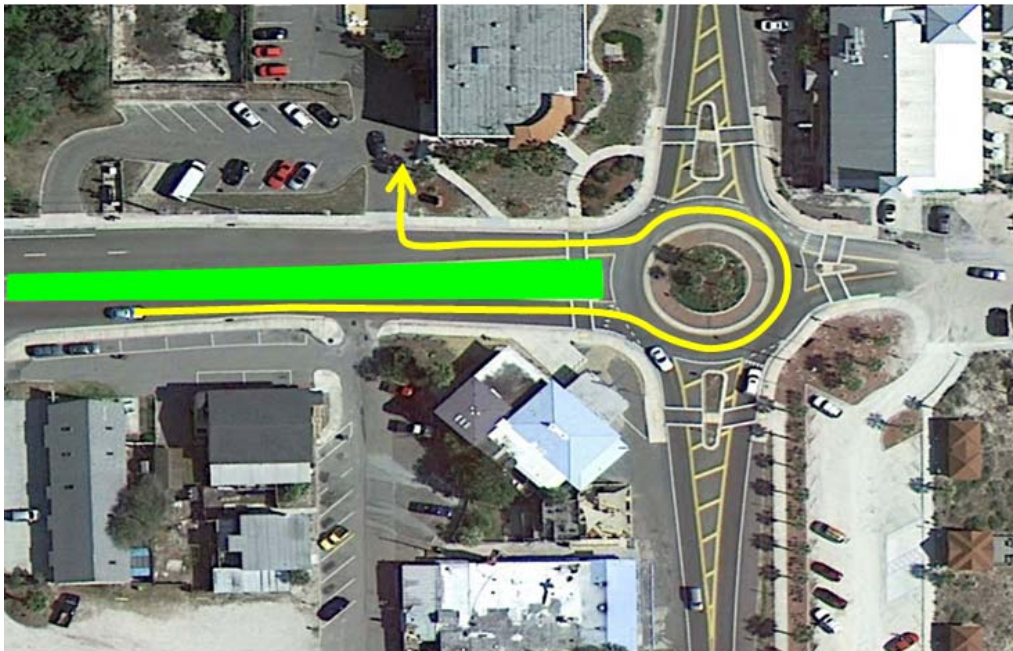

(b) Alternative: Vehicles from Main Street Turn onto a Driveway by Making a U-turn at Downstream Roundabout

Figure 41. Case 1 - Vehicles Turning onto a Driveway Downstream of the Roundabout

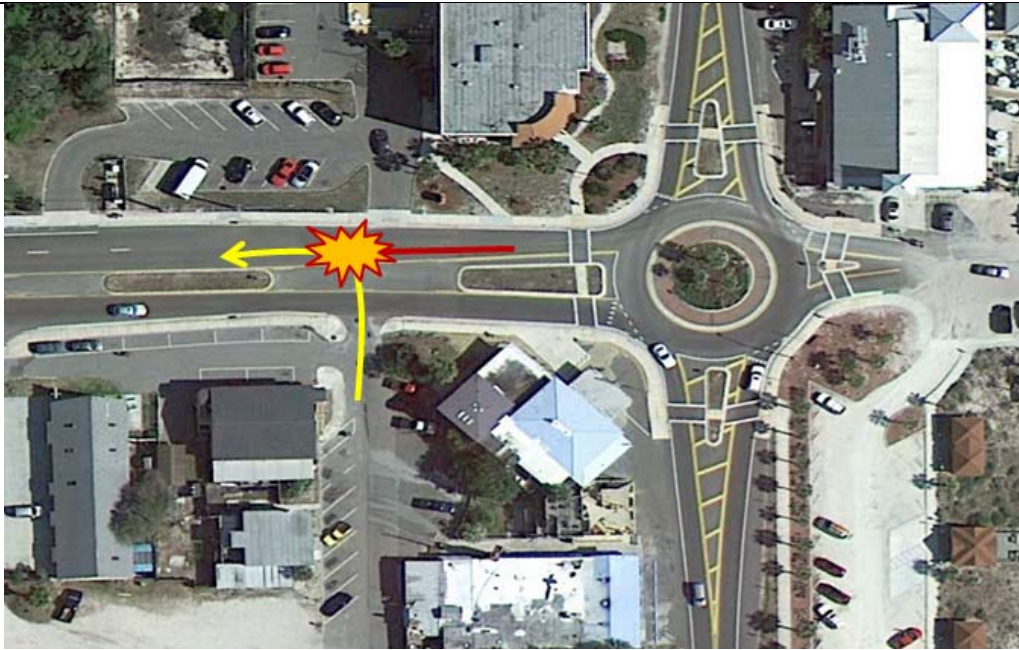

(a) Potential Safety Problem: Vehicles from Driveway Turn Left at Median Opening with Reduced Gaps



(b) Alternative: Vehicles from Driveway Turn Left by Making U-turns at Downstream Roundabout

Figure 42. Case 2 - Vehicles Turning Left from a Driveway Upstream of a Roundabout

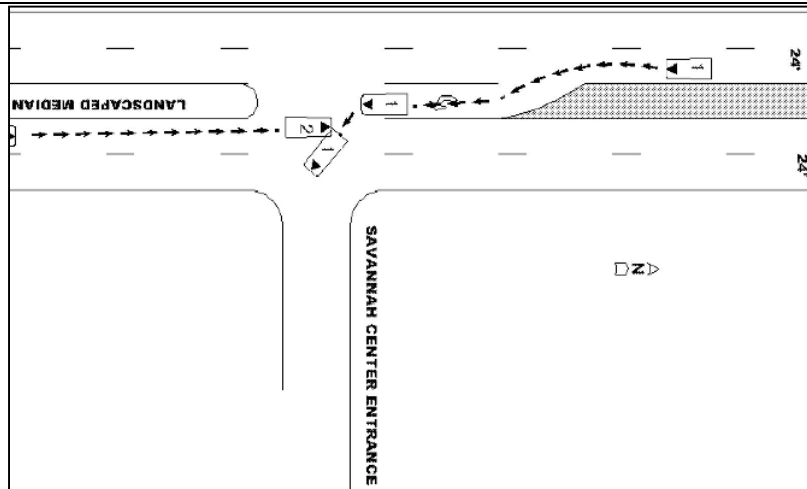

Figure 43. An Example of a Crash at a Median Opening Involving a Vehicle Turning Left From the Main Street Onto a Driveway (Crash ID: 820970050)

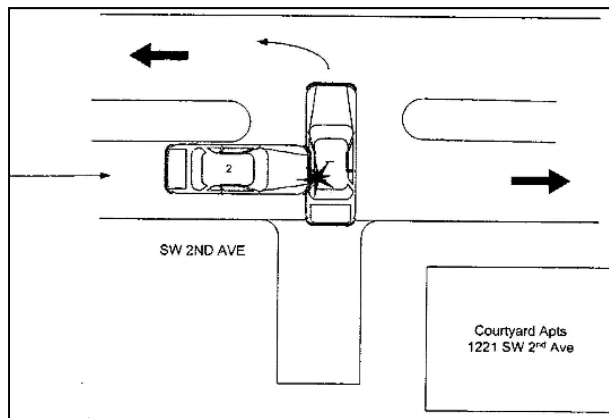

Figure 44. An Example of a Crash at a Median Opening Involving a Vehicle Turning Left From a Driveway Onto the Main Street (Crash ID: 801477040)

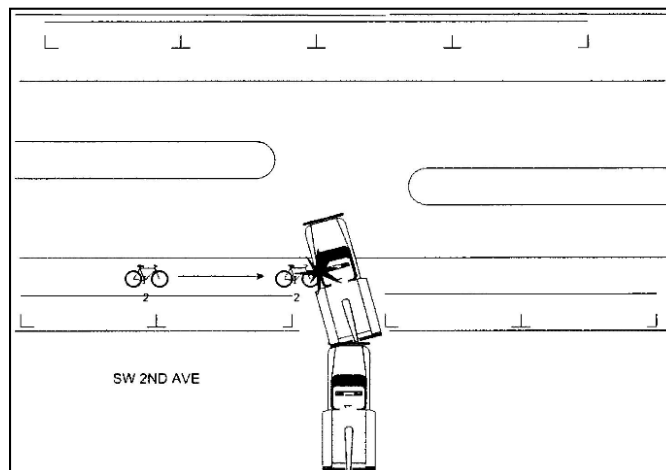

Figure 45. A Non-incapacitating Injury Involving a Vehicle Turning Left from Driveway and a Bicyclist (Crash ID: 801468970)

Given that existing median openings did not pose significant safety problem in terms of both crash number and crash severity, the second question is whether closing the median opening could be beneficial. While it is uncertain how many of the 15 crashes related to the median openings could have been prevented by requiring vehicles to make a U-turn at roundabouts, the U-turn alternative is known to pose two potential traffic operational problems.

First, the U-turn alternative may increase the number of sideswipe crashes at roundabouts especially for large vehicles. Large trucks and buses often find it difficult to negotiate a smaller roundabout. Particularly, lack of adequate lateral clearance could result in heavy vehicles sideswiping other vehicles or becoming involved in a collision with a fixed object, usually with the roundabout center island. During 2007-2011, a total of 18 crashes involving heavy vehicles at the 131 commercial roundabouts. Figure 46 shows examples of these crashes. Vehicle hitting a fixed object, followed by angle and sideswipe crashes were predominantly observed. All of these crashes were found to be PDOs.

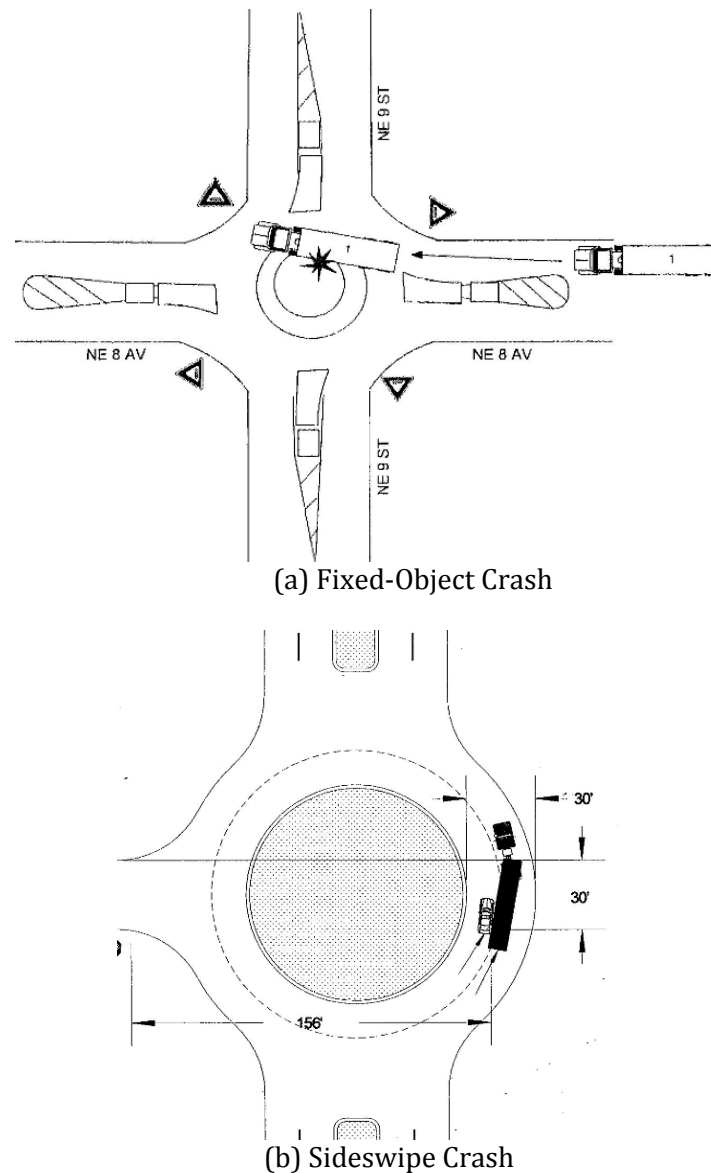

Figure 46. Examples of Crashes Involving Heavy Vehicles at Roundabouts

Second, the U-turn alternative prevents certain turning movements, which may result in crashes elsewhere. Closing the median opening prevents the following two turning movements: (1) it prevents vehicles from turning left from a driveway onto the main street; and (2) it prevents vehicles from turning left from the main street onto a driveway. Figure 47 and Figure 48 illustrate these two scenarios. As shown Figure 47, the vehicle from the driveway cannot turn left onto the main street and the vehicle has to turn right and make a U-turn downstream. Similarly, as shown in Figure 48, the vehicle from the main street cannot turn left onto the driveway when the median opening is closed. The vehicles has to go straight, make a U-turn downstream, and then turn right at the driveway.

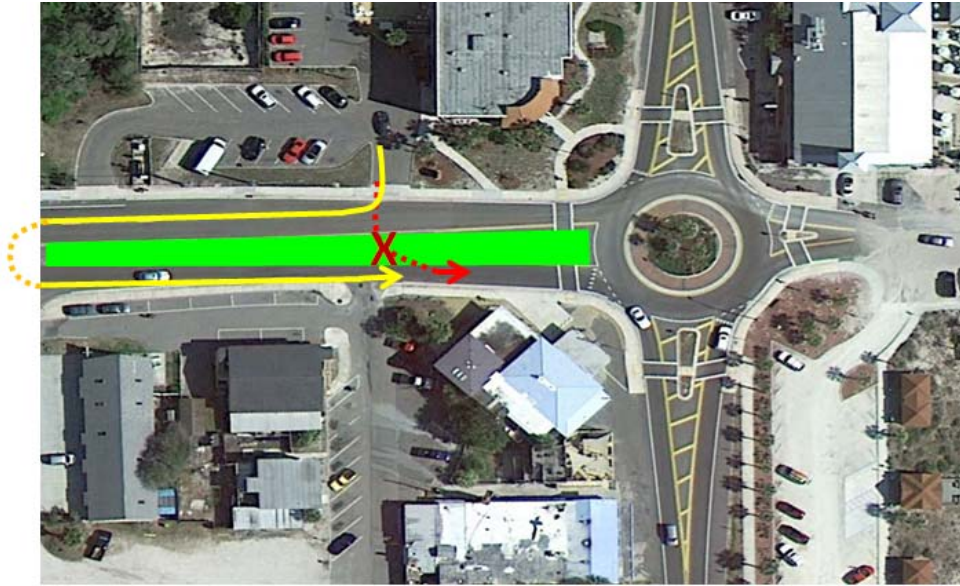

Figure 47. Closing Median Openings Prevent Vehicles From Turning Left From the Driveway Onto the Main Street



Figure 48. Closing Median Openings Prevent Vehicles From Turning Left From the Main Street Onto the Driveway

This limitation, however, suggests that if there is a second adjacent roundabout downstream (i.e., roundabouts in series) to facilitate the U-turns, closing the median opening could become beneficial, as it

could potentially prevent some of the median opening related crashes without making some turning movements difficult. Figure 49 provides an example of a candidate location for constructing raised medians to eliminate left turning movements involving vehicles entering and exiting the driveways. Again, this alternative is viable only with low volume of heavy vehicles or with larger roundabouts that could better accommodate large vehicles.

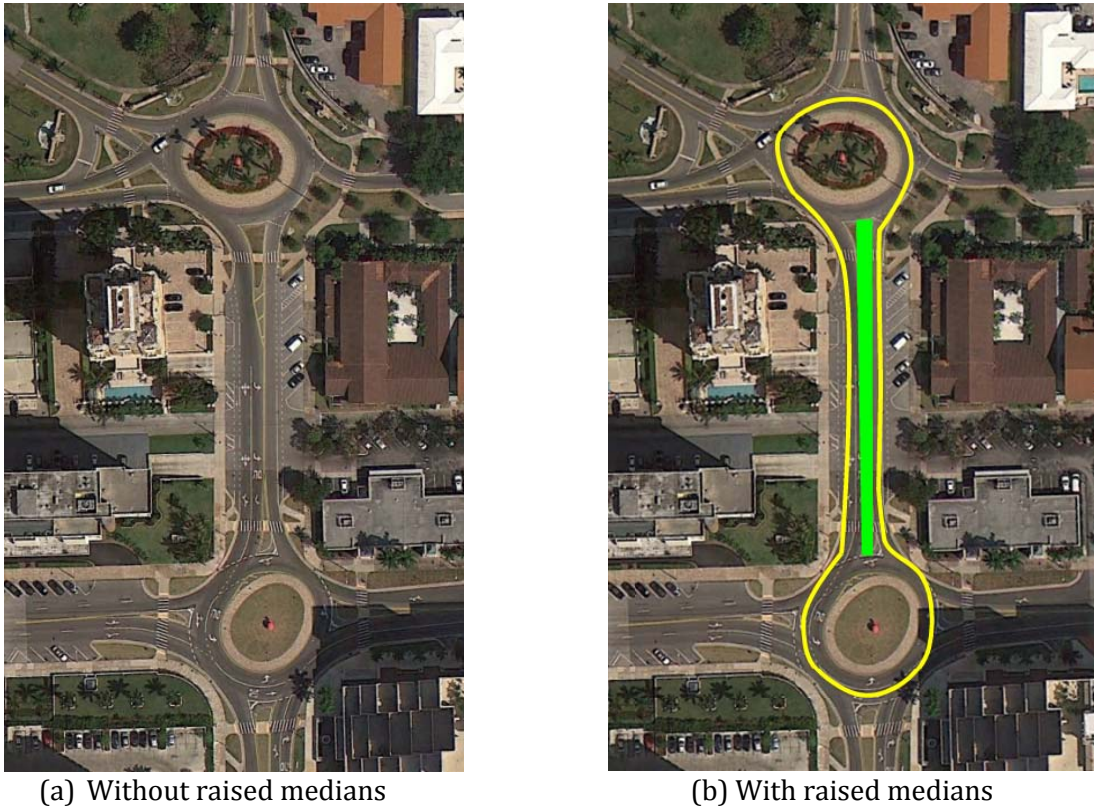

Figure 49. A Corridor with Two Roundabouts on Segovia Street, Miami Dade County, Florida

5.4 Safety at Roundabouts That Provide Direct Access to Activity Centers

Access to major activity centers, such as big box retail stores, shopping centers, and malls, is often provided at mid-block locations on a corridor. Figure 50 gives an example of this scenario. Such access creates an intersection or a major driveway to the detriment of traffic flow on the corridor. One alternative, as shown in Figure 51, is to have the access point connected directly to the roundabout, sending all access traffic through the roundabout circulation lane(s). Do roundabouts that provide direct access to activity centers through a dedicated leg perform less favorably in safety than other roundabouts?



Figure 50. An Activity Center with Access Through a Major Driveway



Figure 51. An Activity Center with Direct Access from a Roundabout

Of the 131 commercial roundabouts in Florida, 19 roundabouts were found to provide direct access to the activity centers. Of these 19 roundabouts, 15 have either three or four legs. The crash experience of three- and four-legged roundabouts with and without direct access to the activity centers was compared using an independent t-test with the following hypothesis:

- H_0 : there is no difference in means (i.e., average crashes per roundabout) between the roundabouts with and without direct access to activity centers ($\mu_1 = \mu_2$),
- H_1 : there are differences in means (i.e., average crashes per roundabout) between the roundabouts with and without direct access to activity centers ($\mu_1 \neq \mu_2$).

Table 25 summarizes these results. At a 5% significance level, the performance of the three-legged roundabouts with and without direct access was statistically insignificant, while the performance of the four-legged roundabouts with and without direct access was statistically significant. Overall, there was sufficient evidence to support the conclusion that at a 5% significance level, there was no significant difference in the performance of three- and four-legged roundabouts with direct access to activity centers and those without direct access.

Table 25. Statistics of Roundabouts with Three and Four Legs

No. of Legs	Roundabouts WITH Direct Access to Activity Centers Through a Dedicated Leg			Roundabouts WITHOUT Direct Access to Activity Centers Through a Dedicated Leg			At a 5% Significance Level, Is the Performance of Roundabouts With and Without Direct Access Significantly Different? ¹
	Total Crashes in Five Years (a)	Number of Roundabouts (b)	Crashes per Roundabout (a/b)	Total Crashes in Five Years (c)	Number of Roundabouts (d)	Crashes per Roundabout (c/d)	
3	23	5	4.6	163	39	4.2	No (p-value: 0.925)
4	33	10	3.3	473	60	7.9	Yes (p-value: 0.021)
3 and 4	56	15	3.7	636	99	6.4	No (p-value: 0.145)

¹ At a 5% significance level, if P-value < 0.05, it is concluded that there is a significant difference in the performance of roundabouts with direct access to activity centers and those without direct access. Similarly, if P-value > 0.05, it is concluded that there is no significant difference in the performance of roundabouts with direct access to activity centers and those without direct access.

The next question is whether it would be beneficial if providing direct access to activity centers results in five or more legs at a roundabout, i.e., more than the typical roundabouts with three or four legs. Table 26 shows the crash statistics of commercial roundabouts with five and six legs. It can be seen that these roundabouts experienced a significantly higher number of crashes, especially in the six-legged case, when compared with those of three- and four-legged. The significant increase in the average crashes is expected as the additional legs quickly increase the number of conflict points in the circulation lanes and become confusing to the drivers. Figure 52 gives examples of two six-legged roundabouts which collectively experienced 154 crashes during the five-year analysis period.

The above crash statistics suggest that providing direct access to activity centers at roundabouts is desirable, but only if it does not increase the number of roundabout legs beyond the standard four legs.

Table 26. Statistics of Roundabouts with Five and Six Legs

No. of Legs	Total Crashes in Five Years (a)	Number of Roundabouts (b)	Crashes per Roundabout (a/b)
5	157	10	15.7
6	213	4	53.3
5 and 6	370	14	26.4

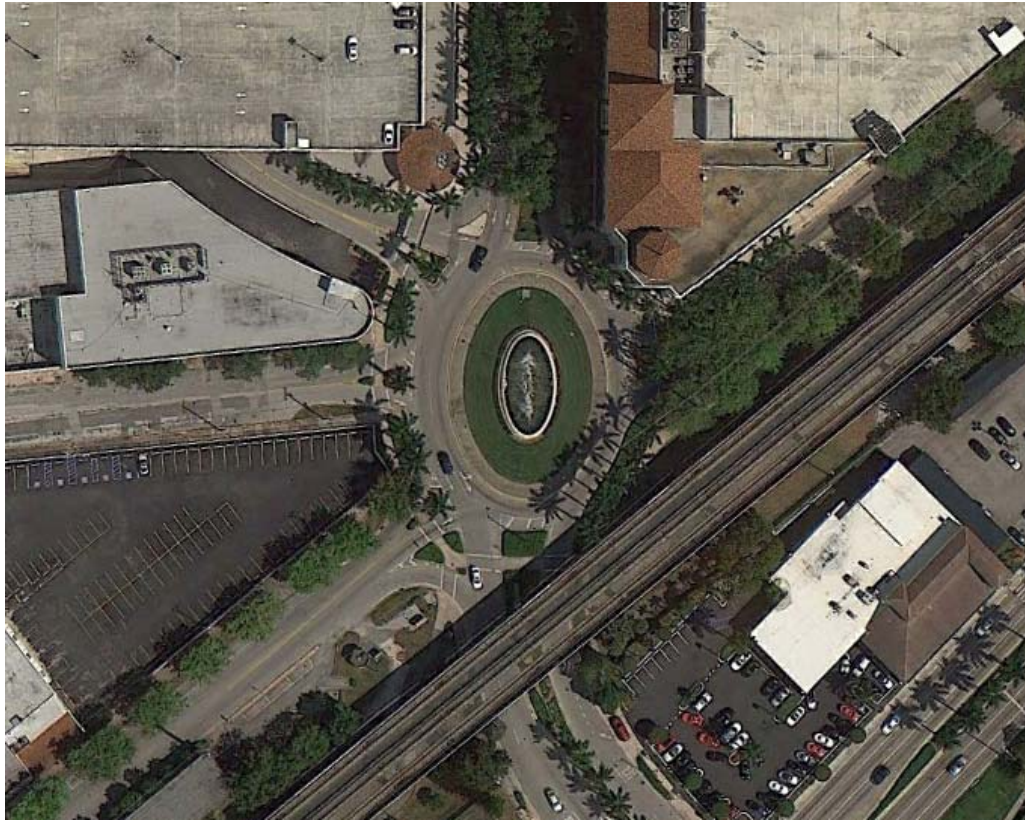

(a) Ponce De Leon, Miami Dade County, Florida



(b) Memorial Causeway Boulevard, Pinellas County, Florida

Figure 52. Examples of Six-legged Roundabouts that Experienced High Crashes

5.5 Safety of Vulnerable Road Users

This section focuses on evaluating the safety of vulnerable road users (i.e., pedestrians and bicyclists) in the vicinity of roundabouts.

5.5.1 Pedestrians

During 2007-2011, the 131 roundabouts in commercial areas experienced a total of 20 pedestrian crashes, constituting 1.06% of the total crashes. Of the 20 pedestrian crashes, one was fatal and two resulted in severe injuries. The fatal crash involved a pedestrian who was intoxicated. Figure 53 gives the illustrative sketch of the crash. Besides this fatal crash, a pedestrian was found to be intoxicated in one other crash, which resulted in a non-incapacitating injury.

Illustrative sketches and descriptions of the 20 pedestrian crashes were reviewed in detail to determine the at-fault road user. Of the 20 pedestrian crashes, 10 (i.e., 50%) occurred due to driver fault, and the pedestrian was found to be at fault in seven crashes (i.e., 35%). For three crashes, identifying the at-fault road user was not possible due to inconclusive information in the police reports. When the pedestrian was found to be at fault, the following were the most frequent contributing causes (number in parentheses indicates the number of related crashes):

- pedestrian obstructed the path of vehicles (3),
- pedestrian failed to yield right-of-way to the vehicle (2), and
- pedestrian was under the influence of alcohol and/or drugs (2).

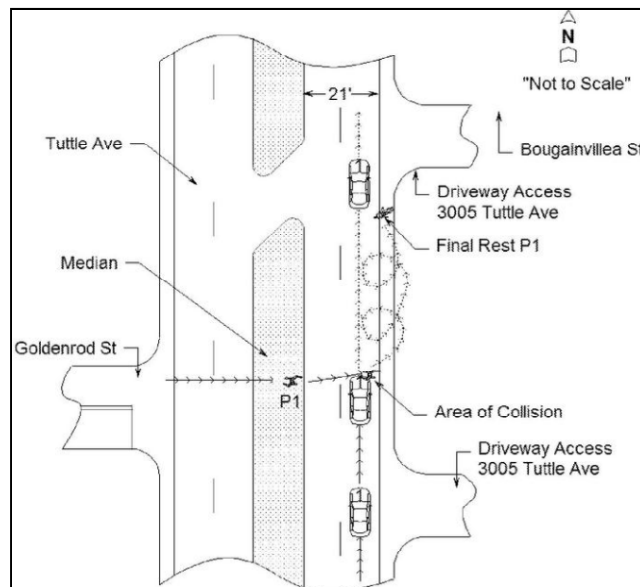

Figure 53. Fatal Crash Involving a Pedestrian (Crash ID: 772427040)

When the driver was found to be at fault, the most frequent contributing causes were:

- careless driving (5),
- driver failed to yield right-of-way to the pedestrian (4), and
- driver disregarded traffic signal or other traffic control (1).

Of the 20 pedestrian crashes, only two crashes occurred at roundabouts, and the remaining 18 crashes occurred on the approach legs. Crashes that occurred on the roundabout legs were reviewed in detail to

identify any specific contributing factors. Table 27 provides pedestrian crash statistics by median type. Of the 18 pedestrian crashes that occurred on the roundabout legs, 11 crashes (61.1%) occurred at raised medians, one occurred on a leg with TWLTL, while the remaining six occurred on undivided sections. From the table, it is also clear that the number of pedestrian crashes per 100 legs was highest for raised medians at 6.40 pedestrian crashes per 100 legs. Further, it was found that all three severe injury pedestrian crashes occurred on approaches with a posted speed greater than 30 mph, and low-speed corridors (i.e., posted speed limit ≤ 30 mph) did not experience serious injuries.

Table 27. Pedestrian Crash Statistics by Median Type

Median Type	Number of Pedestrian Crashes (a)	Number of Approach Legs (b)	Number of Pedestrian Crashes per 100 Approach Legs (a)/(b)
Raised Median	11	172	6.40
TWLTL	1	18	5.56
Undivided Sections	6	281	2.14
Other	0	19	0.00
Total	18	490	3.67

5.5.2 Bicyclists

During 2007-2011, a total of 47 bicycle-vehicle crashes occurred in the vicinity of the 131 roundabouts. Although none of the crashes were fatal, a majority of the crashes resulted in an injury. As it can be inferred from the table, 48.9% of bicycle crashes were a result of driver error while 40.4% of the crashes were due to bicyclist error. When the bicyclist was found to be at fault, the following were the most frequent contributing causes (number in parentheses indicates the number of related crashes):

1. bicyclist failed to yield right-of-way to the driver (7),
2. bicyclist obstructed vehicles' path by either falling off the bike or losing control of the bike into the path of the vehicle (6), and
3. bicyclist rode into a stopped vehicle (3).

When a driver was found to be at fault, the most frequent contributing causes were:

- driver failed to yield right-of-way to the bicyclist (13) and
- careless driving (9).

The corridor on SW Second Avenue in Gainesville has three roundabouts and had 12 bicycle crashes (i.e., 25.5% of total bicycle crashes) during the five-year analysis period. Figure 54 shows the aerial view of this corridor, which is near the University of Florida (UF) main entrance. This corridor was found to have a significant amount of bicycle traffic; this disproportionately high exposure resulted in a high number of bicycle crashes.

Table 28 gives bicycle crash statistics based on where the crash had occurred (i.e., either at the roundabout or on an approach leg). The 131 roundabouts have 490 legs; 86 of these have designated bike lanes. During 2007-2011, these 86 legs experienced eight bicycle crashes, while the remaining 404 legs without designated bike lanes experienced 20 bicycle crashes. However, these statistics do not take into account bicycle exposure data. In other words, locations with designated bike lanes might experience more bicycle crashes simply because more bicyclists use the facility.

The corridor on SW Second Avenue in Gainesville has three roundabouts and had 12 bicycle crashes (i.e., 25.5% of total bicycle crashes) during the five-year analysis period. Figure 54 shows the aerial view of this corridor, which is near the University of Florida (UF) main entrance. This corridor was found to have a significant amount of bicycle traffic; this disproportionately high exposure resulted in a high number of bicycle crashes.

Table 28. Bicycle Crash Statistics by Location and Crash Severity

Crash Severity	Crashes at Roundabout	Crashes on Approach Leg	Total Bicycle Crashes
Fatal Injury	0	0	0
Incapacitating Injury	1	4	5
Non-Incapacitating Injury	12	11	23
Possible Injury	3	9	12
Property Damage Only	3	4	7
Total Crashes	19	28	47



Figure 54. Corridor on SW 2nd Avenue, Gainesville, Alachua County, Florida

5.6 Summary of Findings

A total of 283 roundabouts in Florida were included in the analysis. During 2007-2011, 1,882 crashes occurred within 500 ft. of these roundabouts. Police reports of these crashes were reviewed in detail to investigate the following potential safety concerns associated with roundabouts in commercial areas:

- Impact of driveway corner clearances on roundabout safety.
- Safety impact of median openings in the vicinity of roundabouts.
- Safety at roundabouts that provide direct access to activity centers.
- Safety of vulnerable road users including pedestrians and bicyclists.

On average, each roundabout experienced 6.65 crashes during the five-year analysis period. A majority of crashes were found to be PDOs. Less than 5% of crashes resulted in severe injuries (i.e., fatal injury and incapacitating injury). In terms of crash type, collision with a fixed object, angle crashes and rear-end crashes were predominant, constituting over 60% of total crashes.

During 2007-2011, the 131 commercial roundabouts experienced a total of 74 driveway-related crashes. Of these crashes, 37 (50%) occurred at the first driveway (i.e., the driveway that defines the corner clearance), including 18 that occurred at the upstream driveway corner clearance, and 19 that occurred at the downstream driveway corner clearance. More crashes were found to occur at the first driveway downstream rather than upstream of roundabouts, indicating that downstream driveway corner clearances have a greater safety impact than upstream driveway corner clearances. This result is consistent with the fact that vehicles exiting a driveway downstream of a roundabout experience reduced gaps due to dispersed platoons from the upstream roundabout. Further, larger corner turning radii typical of roundabouts increases vehicle-turning speed. When combined with reduced sight distance due to sight obstructions, the time available for driveway vehicles to complete their maneuvers could be significantly reduced.

At high-volume locations, turning traffic at median openings in the vicinity of roundabouts experience reduced vehicle gaps, which could result in more crashes. To address this potential safety concern, crashes at median openings involving left-turning vehicles were identified. A relatively low total of 15 crashes were found to involve turning vehicles at the median openings, and a majority of these were not severe. Crash data did not indicate any serious safety issues with median openings in the vicinity of roundabouts. Nonetheless, closing the median openings and having vehicles make U-turns at the downstream roundabout could potentially prevent some of these crashes. However, this alternative was found to pose two traffic operational problems. First, this alternative may increase the number of sideswipe crashes at roundabouts especially for large vehicles. The second problem with closing median openings is that it prevents certain turning movements, which may result in migration of crashes. This problem exists because there is not another roundabout available to facilitate all the U-turns needed when median openings are closed. At locations with both upstream and downstream roundabouts (i.e., roundabouts in series), closing the median opening could become beneficial, as it could potentially prevent some of the median opening related crashes without making some turning movements difficult.

Access to major activity centers is often provided at mid-block locations on a corridor. One alternative is to have the access point connected directly to the roundabout (i.e., through a dedicated leg). Of the 131 commercial roundabouts in Florida, 19 roundabouts were found to provide direct access to the activity centers. Average crashes per roundabout at three- and four- legged roundabouts with and without direct access to the activity centers were compared using an independent t-test. At a 5% significance level, there was no significant difference in the performance of three- and four-legged roundabouts with direct access to activity centers and those without direct access. It was also found that roundabouts with more than four legs experienced a significantly higher number of crashes. This was expected as the additional legs increase the number of conflict points within the circulation lanes and become confusing to the drivers. Overall, the crash statistics suggest that providing direct access to activity centers at roundabouts is desirable, but only if it does not increase the number of roundabout legs to beyond the standard four legs.

Safety of vulnerable road users (i.e., pedestrians and bicyclists) in the vicinity of roundabouts was evaluated. During the five-year analysis period, the 131 commercial roundabouts experienced 20 pedestrian crashes. Of these 20 crashes, only two occurred at roundabouts, while the remaining 18 occurred on the roundabout legs. Compared to pedestrian crashes, bicycle crashes were more frequent; during 2007-2011, 47 bicycle crashes were reported. Of these 47, 19 occurred at roundabouts and the rest were on the roundabout legs. Roundabout legs with designated bike lanes resulted in a slightly greater proportion of bicycle crashes compared to those without bike lanes. However, this observation did not take into account bicycle exposure data, which are not available for this study.

Based on the results from the safety analysis, the following general recommendations related to the access features in the vicinity of roundabouts are made:

- Crash data show that downstream driveway corner clearances have a greater safety impact than upstream driveway corner clearances. Longer downstream corner clearances are desirable to provide additional time for driveway vehicles that experience reduced vehicle gaps and higher approach vehicle speed from upstream roundabouts.
- Crash data did not indicate serious safety issues with median openings in the vicinity of roundabouts. However, closing median openings located between two adjacent roundabouts could prevent some of the median opening related crashes and is desirable if the corridor is designed to serve low heavy vehicle volumes or if the roundabouts are sufficiently large to safely accommodate U-turns by heavy vehicles.
- Crash data did not show an increased safety hazard at roundabouts that provide direct access to activity centers. Providing direct access to activity centers through a dedicated leg is desirable to improve traffic operations on the corridor if the provision does not increase the number of roundabout legs to beyond the standard four.

Chapter Six: Operational Analysis

This section presents the findings of the operational analysis of roundabouts and access management. Analysis of conflicts (involving vehicles, pedestrians and bicyclists, etc.), access to driveways and violation of traffic rules at roundabouts are conducted to summarize the issues related to access management.

6.1 Overview of Data Collection Sites

Site observations and data collection were conducted at the 13 selected sites in Florida. Details of the roundabouts are included in Appendix D. In general, the sites were selected based upon traffic volume, proximity or location on state highways, or in close proximity to driveways. A diversity of conditions were selected for the following characteristics: single and multiple lanes, commercial and mixed-lane uses adjacent to the roundabout, proximity to parking, a single isolated roundabout and a roundabout corridor.

All 13 roundabouts selected for observation are considered to have at least a moderate traffic volume level during peak periods. Seven sites are single-lane roundabouts and five are multi-lane roundabouts. The other is considered a complex roundabout, which include spiral roundabouts, turbo roundabouts or a roundabout that has multiple slip lanes. Nine sites are located in commercial areas; the remaining four are located in a mixed-use area. All of the sites have a driveway nearby. All of them have driveways near both access and egress legs of the roundabout. Seven of the sites have driveways near both the access and egress approaches of the roundabout. Two sites have driveways in the middle of the roundabout. All of the sites are located near state highways, and one is on a state highway. Two sites are located on streets with on-street parking, wherein the parking maneuver on the street could affect the operating speed, safety, and perhaps access of the roundabout. Four sites are located in a series of several roundabouts. The literature suggests that a series of roundabouts in a corridor, particularly a commercial corridor, can provide a more aesthetically pleasing area, slow traffic, and improve access and safety. Building a series of roundabouts can create a vibrant business area. Therefore, it is desirable to look at the performance and access issues of a series of roundabouts.

6.2 Analysis of Access Management Issues Affecting Operations

During the field observations, several access management issues were identified at the roundabouts. These include: (1) conflict at access points within the functional area, which includes intersections of a driveway and approaching lane of a roundabout, and the impact of queuing on the operation of a nearby stop-controlled driveway; (2) conflicts at roundabouts involving pedestrians and bicyclists; and (3) violation of traffic rules and its impact on the roundabout operations. Each of these issues is addressed separately below.

6.2.1 Conflicts at Access Point within Roundabout's Functional Area

If an access point, such as a driveway or another intersection, is located within the roundabout functional area, vehicle conflicts may occur and compromise the operation of the roundabout. The conflict between a vehicle making a left turn into a driveway and the opposing traffic flow entering the roundabout was a common field observation. Figure 55 shows an example that was observed at SW 2nd Avenue and SW 6th Street in the City of Gainesville in Alachua County. The driveway is located near a roundabout (60 ft.). When the queue spills back at the left-turning lane, left turning vehicles from the exiting lane into the driveway can be blocked at the turning bay, causing a spillback into the roundabout, which then interferes with the operation of the entire intersection.

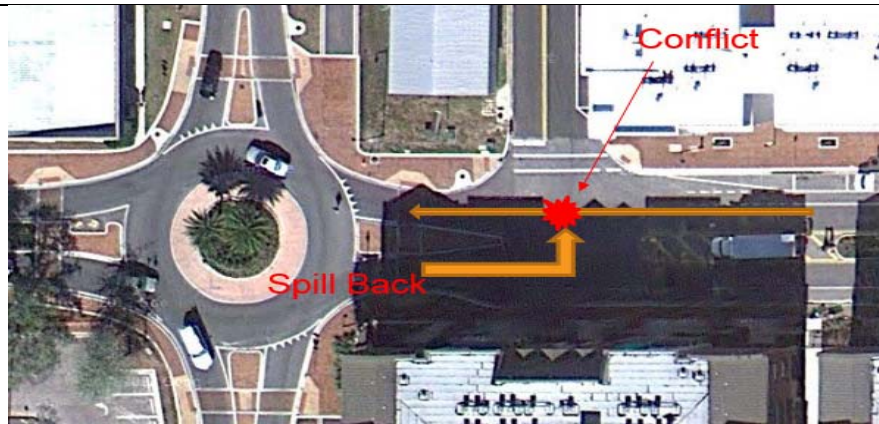

Figure 55. Conflict of Left-turn Vehicle at Roundabout (SW 2nd Avenue and SW 6th in Alachua County)

Another case is when an AWSC driveway is close to a roundabout. In this situation, the traffic entering the roundabout can spill back into the driveway. Figure 56 shows a roundabout in Miami-Dade in which the traffic spills back from the approaching lane and blocks the operation of the AWSC driveway. A certain distance is clearly needed between the roundabout and the nearby intersection.



Figure 56. Roundabout Observation on Spill Back of Entering Traffic into an Adjacent AWSC Intersection (NE 10th Ct. and SW 152nd Ave., Miami)

6.2.2 Conflicts with Pedestrians

Figure 57 shows the interaction between pedestrians and vehicles at Independent Drive and South Laura Street, in Jacksonville. Since this roundabout is located in a business and commercial area, we can observe a relatively high flow of pedestrian traffic. When a car stops for a pedestrian at a crosswalk, the queue behind the car spills back into the circulating lane, and affects the operation of the roundabout.



Figure 57. Roundabout Observation with Pedestrian Conflict (Independent Dr. and S. Laura St., Duval County)

6.2.3 Violation of Traffic Rules

There are several cases where drivers violate traffic rules and stop in the middle of roundabouts. Figure 58 shows a case at Independent Drive and South Laura Street, in Jacksonville, where the roundabout is placed near a business and shopping center downtown. People tend to pick up people at the roundabout and cause a queue back-up in the circulating lane.



Figure 58. Roundabout Observation with Driver Violation of Traffic Rules (Independent Dr. and S. Laura St., Duval County)

Another example of violation of traffic rules is when vehicles stop at the driveway and pick up people. The queue spills back into the circulating lane and causes one lane to jam. Cars in this lane try to change to the other circulating lane and disrupt the operation of the roundabout.



Figure 59. Roundabout Observation with Spill Back from Driveway into Circulating Lanes (Causeway Blvd. and Mandalay Ave., Pinellas County)

6.2.4 Summary of Operational Analysis

In most cases, roundabouts operate in a manner similar to other types of intersections, such as non-signalized intersections. Thus, from an operational perspective, access management, should be managed in a way that is similar to other intersections. However the combination of roundabout and access management does have some unique features for operations.

In summary, the following suggestions are made to counter the problems found in the site observations. Before the design and construction of the intersection, the distance between the roundabout and nearby driveways should be carefully considered in order to keep the driveway and roundabouts in operation. The distance between the roundabout and the nearby intersection should also be carefully considered and enough storage capacity should be provided to keep the roundabout and any adjacent intersections functioning properly. If the traffic volume is moderate and the percentage of heavy vehicles is low, when a driveway has to be located close to a roundabout, a median closing should be used and another roundabout at the next intersection is recommended to allow U-turns for accessing driveways. If a roundabout has less than 4 legs, access to nearby activity centers should be provided by using a separate driveway, instead of linking the roundabout to the activity center itself (as shown in Figure 58 where vehicles stopped in the roundabout to pick up a passenger); if more than 4 legs are included, traffic designers should avoid adding one more leg to the roundabout based on the findings in Chapter 5. Additionally, driver education is necessary to maintain roundabout operations.

6.3 Assessment of Software

A number of software packages can be used to analyze the operational effect of roundabouts. Based on their methodology, we can divide them into two different groups: deterministic software tools and simulation tools. Deterministic methods model vehicle flows as flow rates and are sensitive to changes in flow rate and the geometric design of roundabouts (Rodegerdts et al., 2010, p. 4-18). Macroscopic analysis tools also fall into this category (Trueblood, 2013). Examples of software packages that implement deterministic analysis methods are Highway Capacity Software (HCS), ARCADY, Roundabout Delay (RODEL), SIDRA, and Synchro. Microscopic simulation is another way to model roundabouts. Such tools can model and display individual vehicles and thus are sensitive to factors at that level: car-following behavior, lane-changing behavior, and decision-making at intersections such as gap acceptance (Rodegerdts et al., 2010, p. 4-19). Examples of software packages that perform microscopic simulation are CORSIM and VISSIM.

6.3.1 HCS

HCS stands for Highway Capacity Software, which is a software package that implements the deterministic, macroscopic analysis methods of the *Highway Capacity Manual*. The process it employs is the *Highway Capacity Manual* procedure, which uses critical gap and follow-up time along with turning movement to compute the capacity of each approach. The newest version of HCS 2010, based on the HCM 2010, provided a new analytical method in assessing roundabout operations. Approach control delay, approach LOS, intersection delay and intersection LOS can be calculated by the software (TRB, 2010a).

The methodology in HCM 2010 focused on the operation of roundabouts within the boundaries of the roundabout. This methodology provides a combination of an empirical approach and an analytical approach for evaluating roundabout operations based on recent U.S. field data (Rodegerdts et al. 2010). Evaluation for both single-lane and double-lane roundabouts are provided in HCM 2010. Therefore in HCS, we can only model roundabouts with two or less circulating lanes.



Figure 60. Interface of HCS 2010

In Table 29. Input and Output for Roundabout Components in HCS 2010, the input for calculation roundabouts in HCS 2010 is shown. Since HCS 2010 adopted the methodology in HCM 2010, more features have been available in assessing roundabout performance.

Table 29. Input and Output for Roundabout Components in HCS 2010

Input	
Parameters	HCS 2010
Turning Flows	Input
Peak Hour Factor	Input
Critical Gap	Input
Follow-up Headway	Input
Output	
Performance Measures	HCS 2010
Capacity	Yes
Approach Delay	Yes
Approach LOS	Yes
Queue	Yes
Intersection Delay	Yes
Intersection LOS	Yes

The two most important parameters in the HCM2010 roundabout model are critical gap and follow-up headways. These two values play an important role in the operational analysis of both single-lane and double-lane roundabouts (TRB, 2010a). One of the disadvantages of the HCM2010 model for assessing roundabout and access management is that it doesn't account for effects related to geometry such as lane width, or traffic flow from adjacent intersections (Trueblood, 2013). HCS 2010 has the ability to calculate roundabout approach queue lengths. This feature is essential to understanding access management issue related to roundabouts.

6.3.2 Synchro

Synchro is an analysis tool for studying intersections at a macroscopic scale. Similar to HCS, Synchro can also be used to assess roundabout performance based on the HCM2010 methodology. Coding a roundabout is very straightforward within Synchro. The user only needs to specify the intersection control type as a roundabout after setting up an intersection with the specific geometry and volume data. If the HCM2010 method was selected in Synchro, the output results should be presented in the manner shown in Figure 61.

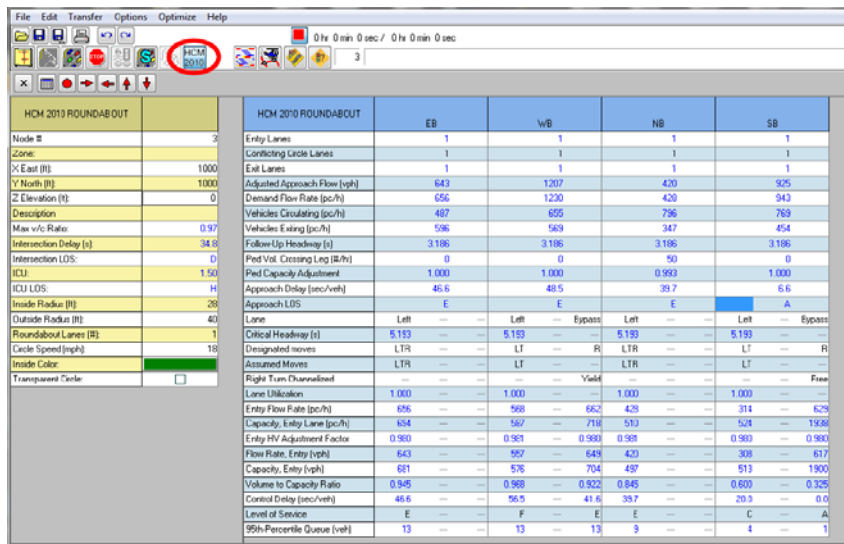

Figure 61. User Interface of Synchro (Trueblood, 2013)

Synchro also comes with a micro-simulation tool called SimTraffic. This tool allows the user to design and evaluate advanced roundabouts designs that exceed the HCM 2010 methodology limitations. For instance, HCS cannot model roundabouts with more than two circulating lanes (Trueblood, 2013). Synchro can also assess the performance of a series of roundabouts in a corridor.

6.3.3 SIDRA

SIDRA was originally developed by ARRB Transport Research Ltd. and later by Akcelik & Associates (Akcelik & Associates, 2014). It is one of the most widely used roundabout analysis software programs in the United States (Jacquemart, 1998). The model is based on an analytical method, which uses gap-acceptance techniques to determine roundabout capacity, delay, queue length, and other performance measures. Similar to the HCM2010, SIDRA includes two important gap parameters: critical gap and follow-up headway. The critical gap and follow-up headway values can be either specified by the user or automatically estimated by SIDRA according to the geometry and flow conditions at each entry (Yin et al., 2011).

Although SIDRA was developed in Australia, it does include several model options to account for roundabout capacity differences in other parts of the world. An environment factor of 1.2 was adopted as a global calibration factor for the SIDRA version issued in the United States (Yin et al., 2011). This factor adjusts the critical gap and follow-up headway values; therefore the capacity value is adjusted downward and the resulting roundabout performance measures will be worse than those for a roundabout in Australia, all else being equal. The newest version of SIDRA can accommodate both HCM model and SIDRA mode.

6.3.4 RODEL and ARCADY

The software ARCADY was developed by Transportation Research Lab (TRL) in the United Kingdom. It uses a linear regression formula to predict capacity, queue length, delays, and crash frequencies as a function of geometry (Elias, 2009). Queues and delays were based on time-dependent queuing theory. ARCADY can model roundabout with the inclusion of crash prediction, geometric delay, and pedestrian crossing (Waddell, 1997).

RODEL stands for Roundabout Delay, which was first developed in 1987. It is used to experiment with different geometric designs of roundabouts. RODEL can provide capacity estimates, average and maximum delay, queues for each approach, and an estimate of overall delay (Elias, 2009). RODEL can use observed variation in capacity to allow the users to set their desired confidence level. The inclusion of statistical variability in RODEL gave designers a precise level of confidence that their designs would meet the requirement of capacity and delay with significant flexibility (Waddell, 1997). RODEL can also provide the maximum probable queue over 40 days rather than the average queue as in other roundabout models. (Waddell, 1997).

6.3.5 VISSIM

VISSIM is a micro-simulation program developed by PTV in Germany (PTV Group, 2013). Critical features in VISSIM, such as link and connectors, routing decisions, priority rules, and reduced speed zones, provides a realistic representation of roundabout traffic operations (Trueblood and Dale, 2003).

VISSIM uses a link and connector system rather than the link and node system that CORSIM uses. This system allows VISSIM to emphasize the link by using connectors to join different links without considering

the node. For roundabout simulation, this system is suitable since a link in VISSIM allows multiple internal inflection points without affecting the simulation of traffic flow (Trueblood and Dale, 2003).

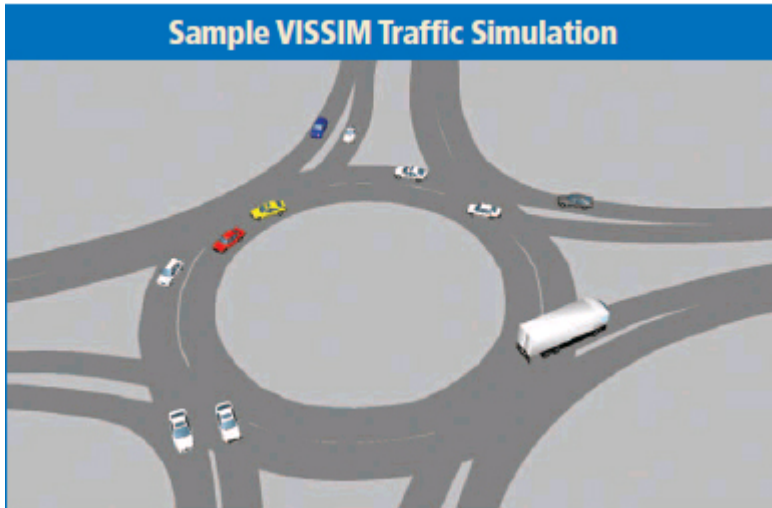

Figure 62. Example of Roundabout Simulation in VISSIM (FHWA, 2011)

Many other features in VISSIM facilitate its usage to simulate traffic movement through a roundabout. The availability of setting route choice decisions in VISSIM allows the user to determine a specific path through a roundabout and the specific volume percentage. Therefore it also allows a user to specify which lane a vehicle uses to complete its routing decision through multi-lane roundabouts (Trueblood and Dale, 2003). The priority rules in VISSIM allows users to specify the yield process at the conflict point. Adjustment of gap-acceptance times, depending on different vehicle types, can also be determined using the setting of priority rules (2003). Reduced speed zones in VISSIM are also great features to use in modeling roundabouts, since vehicles usually slow down to 15-25 mi/h to circulate the roundabout (2003). VISSIM provides a flexible tool for users to accurately simulate the operation of roundabouts. Research also pointed out that VISSIM allows users to fine-tune the gap acceptance parameters required for the simulation (Stanek and Milam, 2005). With great flexibility and accurate features, it is believed that VISSIM is the best micro-simulator for roundabout modeling (Elias, 2009).

6.3.6 CORRIDOR SIMULATION (CORSIM)

CORSIM includes two microscopic simulation subprograms, NETSIM and FRESIM that are specialized for urban streets and freeways, respectively. Although it is widely used in the United States, CORSIM has limited capabilities for simulating roundabouts (Elias, 2009). Since CORSIM uses a link and node structure to model a transportation network, with nodes being intersections and links representing the connecting roadways, it does not provide a direct representation of roundabouts. To model a roundabout in CORSIM, the user needs to create a separate node for each approach and connect these nodes together with a one-way link segment in a counterclockwise direction as shown in Figure 63. (Elias, 2009).

The inputs for roundabout simulation in CORSIM include the following: approach volumes for each leg, origin-destination of all traffic, geometric characteristics, and speed distribution. The outputs from CORSIM include control delay, average queue, and maximum queue, and other standard performance measures.

When starting the simulation, the vehicle entry headway distribution should be modified based on field data to closely match the arrivals at each approach. Then the user needs to connect each approach using a counterclockwise one-way link as in Figure 63. It is important to verify that the length of the one-way link matches the size of the actual roundabout. In order to replicate the traffic rule at roundabout, it is important to implement yield control at each approach lane. The final step is to adjust the gap acceptance

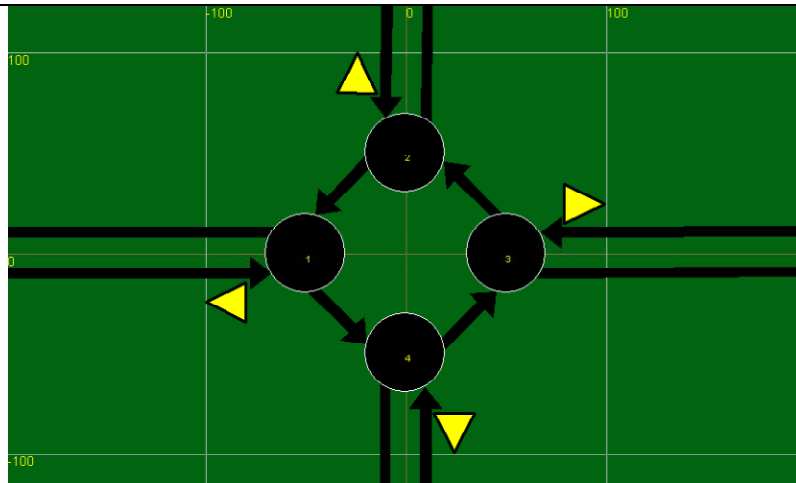

Figure 63. Example of Modeling Roundabout in CORSIM (Elias, 2009)

model to match the finding on roundabout driver behavior. Additionally, it is possible to model origin-destinations in CORSIM using conditional turn movements (Elias, 2009).

One major difficulty in modeling roundabouts in CORSIM is the input of turn movements. Since roundabouts are replicated using different segments of links connected with each other by joining nodes with approaches, the turn movements need to be set based on conditional logic as shown in Figure 64.

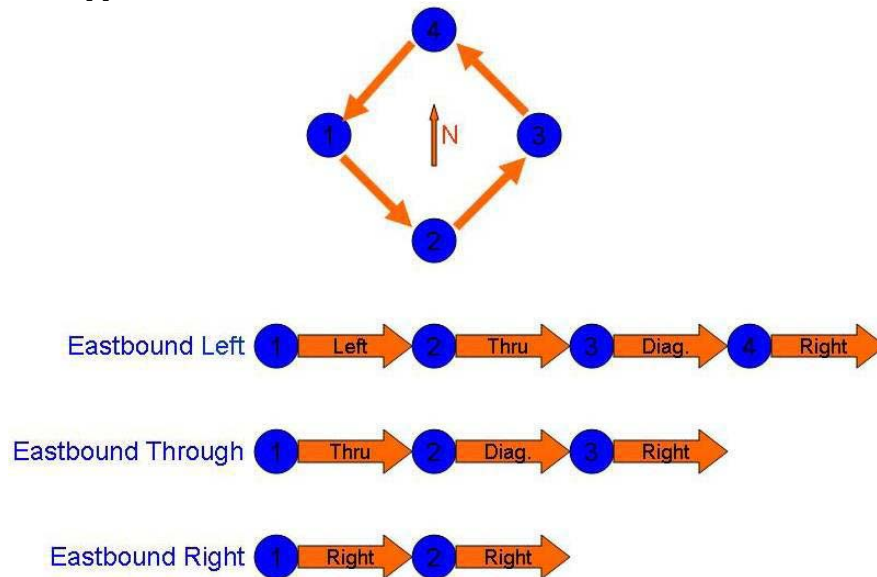

Figure 64. Conditional Turn Movement in CORSIM (Elias, 2009)

Research showed that the output of CORSIM when simulating roundabouts is inaccurate and quite different from site observation. Average queue was least well predicted for the three performance measures (Elias, 2009). This could potentially bring some difficulties when using CORSIM for modeling roundabouts, especially for access issues.

6.3.6.1 Improvement of CORSIM for Roundabout Modeling. Since CORSIM does not provide a direct method for roundabout simulation, several revisions to CORSIM’s default parameters should be conducted before simulating roundabouts (Elias, 2009). Based on the research of Elias, the current version of CORSIM does not replicate roundabout operations accurately (Elias, 2009). Although CORSIM has all the necessary features for roundabout simulation, improvements should be considered in order to give CORSIM the

ability to model roundabouts well. (Elias, 2009). Elias (2009) has made the following recommendations for improvements to CORSIM:

- Multiple nodes should be able to be grouped together as a roundabout. Once grouped, the software seeks inputs for inscribed diameter and super-elevation. The program then uses this information to calculate the limiting speed for circulating vehicles.
- Add inputs for turn movements and conditional turn movements at each approach node.
- Revise critical gap and follow-up time parameters to be approach specific. Default values should be based on NCHRP 3-65, with the ability to overwrite based on available field data. Adjust the link lengths and curvature for realistic animation in TrafVu.

6.3.7 Summary

The software packages included in the assessment section are those which are often used to analyze roundabout operation. In sum, deterministic software, such as HCS, Synchro, SIDRA, RODEL and ARCADY, can perform queuing analysis and provide useful information related to access management, especially for placing driveways. Simulation software, such as VISSIM, can be used to evaluate the operation of roundabouts and the interaction between traffic flows at roundabout and adjacent driveways by conducting microscopic analysis. It is clear from this analysis that deterministic software can provide guidance on where the driveway should be placed before construction of intersections, while simulation can be used to evaluate the impact of driveway and other access management issues on roundabout operation. HCS can do queuing analysis, which can determine the recommended distance between the roundabout and adjacent driveways. Table 30 shows the recommendation for selection of analysis tool for different design and evaluation applications regarding roundabouts and access management.

Table 30. Recommended Selection of Analysis Tool for Different Applications Regarding Roundabouts and Access Management

Application	Expected Outcome	Required Input	Potential Analysis Tool
Planning driveway location	Distance of driveway to roundabout (vehicle queuing)	Traffic volume, roundabout geometric characteristics	HCM, deterministic software
Pedestrian access at roundabout	Vehicle delay, vehicle queuing, pedestrian delay	Traffic volume (vehicle and pedestrian), crosswalk design	HCM, deterministic software, simulation
Access to activity center, parking	Vehicle delay, vehicle queuing	Traffic volume,	Simulation
Evaluation of interaction between driveway and roundabout	Delay and queues between intersections, travel time	Traffic volume, roundabout geometric characteristics	Simulation

Other major software package that the FDOT uses for performing LOS analysis is LOSPLAN. However, at this time, the ability to analyze roundabouts is not included in any of the LOSPLAN component software programs: ARTPLAN, FREEPLAN, and HIGHPLAN. Therefore discussions of these software packages are not included in this study. Further development of such software packages may take roundabouts into consideration. Some software packages, such as CAP-X (developed by FHWA), GIRABASE (French) and Kreisel (German), can also analyze roundabouts, but are not currently used by FDOT.

Chapter Seven: Discussion

7.1 Overview

Florida has recently begun to encourage the use of roundabouts on the state highway system and is systematically updating its guidance documents (e.g., Plans Preparation Manual, Intersection Design Manual, and Manual on Uniform Traffic Studies) but needs advice on what to include in the *Median Handbook*, and *Driveway Information Guide*. The policy justification for this change in policy results from increasing evidence that roundabouts may cost less to install, have greater safety potential by reducing the number of conflict points, and depending upon the context, have lower operations and maintenance costs. To accomplish this goal it is important to understand the connection between roundabouts and access management and other forms of traffic control.

Roundabouts are being implemented in a variety of contexts, but existing research does not provide detailed guidance to evaluate how the roundabouts can be implemented as a form of access management. Access management is defined by the TRB Access Management Committee as “the systematic control of the location, spacing, design, and operation of driveways, median openings, interchanges, and street connections to a roadway” (TRB, 2003, pp.3). Roundabouts facilitate U-turns that can substitute for mid-block left turns and, when incorporated into a corridor of multiple roundabouts, can accommodate a series of U-turns and left-turn lanes that can reduce delay in the corridor (Rodegerdts et al., 2010). Left-turn lanes and median openings can be reduced or even eliminated as vehicles that want to make a left turn can make a U-turn and then a right turn to a driveway. However, because of their operational characteristics, roundabouts “may also reduce the number of available gaps for mid-block signalized intersection and driveways” (Rodegerdts et al., 2010, p. 29). This may just reduce the capacity at these access points. At the very least, the traffic along a corridor changes with the introduction of roundabouts; the traffic may be more uniformly distributed with a large number of smaller gaps rather than fewer larger ones. Additionally, a single roundabout functions differently than a corridor of roundabouts; a corridor of roundabouts cannot be actively managed to provide priority to a major street corridor in the same way that coordinated platoons of traffic can be managed to improve the efficiency of traffic signals. Furthermore, “roundabouts cannot be managed with a centralized management system to facilitate special events, divert traffic flows, and so on unless signals at the roundabouts or in the vicinity are used for such a purpose” (TRB, 2010a, pp. 2-6).

Developing guidance for access management near roundabouts is further complicated by the need to understand their benefits and challenges for the variety of users of the roadway. While, in most contexts, roundabouts are generally found to be safer than the previous treatments in before-and-after studies (Kittelsohn & Associates, Inc. 2013), the actual and perceived safety of roundabouts varies among users. Yet, roundabouts are not always safe for all users. In particular, in some contexts, pedestrians, especially those with visual impairments, bicyclists, and truck drivers may face specific challenges in navigating through roundabouts. The use of roundabouts and other access management techniques may establish priority for specific movements at or near roundabouts that affect their operations.

The purpose of this study is to understand previous research on roundabouts and access management, to document how other states are providing guidance on roundabouts and access management, and to provide empirical research on the safety and operations of roundabouts in Florida. The purpose is to present information about incorporating guidance on roundabouts and access management into the access management guidelines, in general, and, specifically, into the *Median Handbook*, and *Driveway Information Guide*.

This chapter is organized as follows. First, the context for understanding the research is provided by describing gaps in the literature, and the results of safety and operational analysis. Next, the findings from

the review of national and states' guidance on roundabouts and access management are summarized. Based upon these results, specific recommendations are made regarding the need for additional research on roundabouts and access management, specific guidance for the roundabouts and access management, and recommendations for software to analyze the operations at roundabouts.

7.2 Roundabouts and Access Management in Florida

The state of Florida has a relatively large number of roundabouts that are safely operating and providing the operational efficiencies of roundabouts, but few of them are located on the state highway system. The research team identified a total of 283 roundabouts throughout the state but only four of those roundabouts are located on the state highway system. The roundabouts are located in a variety of regional contexts with diverse designs and access considerations. The regional context varies from urban to suburban to rural and different distances from the nearest community centers, highways, interstates, and state highways. The design of the roundabouts varies from the more common three or four leg roundabout to roundabouts with up to six legs. The type of roundabout varies from a single-lane to multi-lane and turbo, spiral and other complex roundabout designs. Some roundabouts have medians on one or more legs, slip lanes and stub-outs. Access considerations involve driveway placement, the presence or absence of medians, and the type of adjacent land uses, which include residential single-family, residential multi-family, commercial and mixed-use. Although only four are located on the state highway system, the majority are located near state highways and in some cases provide access that allows drivers alternatives to using the state highway system.

In this section, a summary of the safety and operational analysis is presented. The safety analysis considered four different aspects of safety related to access management near roundabouts: (1) impact of driveway corner clearances on roundabout safety; (2) safety impact of median openings in the vicinity of roundabouts; (3) safety at roundabouts that provide direct access to activity centers; and (4) safety of vulnerable road users, including pedestrians and bicyclists. Next, the results of the operational analysis were summarized by considering three different aspects of the operations of roundabouts: (1) conflicts within the functional area of roundabouts; (2) conflicts at roundabouts involving pedestrians and bicyclists; and (3) violation of traffic rules and their impact on the operation of roundabouts. Then, a summary of the analysis of the review of the national and state guidance on roundabouts and access management is presented. Finally, the Florida guidelines for roundabouts and access management are explored and the results are placed within the context of Florida practice.

7.2.1 Summary of Safety Analysis

The findings of the safety analysis on each of the four different aspects of safety are addressed after the summary of the crash data is presented.

7.2.1.1 Summary of Overall Crash Data. A total of 1,882 crashes within 500 ft. of the 283 roundabouts located in Florida that were directly related to the roundabout were found to occur during 2007-2011. Overall, each roundabout experienced an average of 6.65 crashes per roundabout during the five-year analysis period with commercial roundabouts experiencing 8.10 crashes per roundabout while residential roundabouts experienced 5.4 crashes per roundabout during the five-year analysis period. Consistent with the previous findings on the safety of the roundabouts, an analysis of all of the crashes related to roundabouts showed a relatively fewer crashes.

A collision with a fixed object was the most frequent crash type, with about a quarter (24.7%) of all crashes in the vicinity of roundabouts resulting from vehicles hitting a fixed object, mostly, the roundabout center island. About two-thirds (62.9%) of these crashes (i.e., collision with a fixed object) occurred at night. After collision with a fixed object, angle and rear-end crashes were most common, accounting for 21.0% and 18.5% of total crashes, respectively. The distribution of crash types was found to be similar in commercial and residential areas.

Overall, about one-third of the total crashes were single-vehicle crashes, while the rest involved multiple vehicles; these crashes were equally distributed across commercial and residential areas. One half of one percent (0.5%) of all crashes had a fatality, 4.5% involved an incapacitating injury, and about a third (29.7%) involved a possible or non-incapacitating injury; the remaining 61.1% involved only property damage. Single-vehicle crashes (8.9%) had a higher proportion of severe injuries than multi-vehicle crashes (2.9%) and a greater percentage of single-vehicle crashes resulted in injuries compared to multi-vehicle crashes. A higher percentage of multi-vehicle crashes, at 68.8%, resulted in PDO crashes, while only 45.9% of single-vehicle crashes were PDOs. Of the six fatal single-vehicle crashes, five involved vulnerable road users (four were motorcyclists who were found at fault and one involved an intoxicated pedestrian). Two of the four fatal multi-vehicle crashes involved a golf cart.

7.2.1.2 Impact of Driveway Corner Clearance on Roundabout Safety. Of the 1,882 crashes that occurred at roundabout legs, only 74 crashes, or about 4%, were identified to be driveway-related. Of these 74 driveway-related crashes, 37 crashes (50% of the driveway-related crashes) occurred at the first driveways (i.e., the driveway that defines the corner clearance), while an equal number occurred on all other driveways. Of the 37 crashes, 18 occurred at the first upstream driveway, and the remaining 19 occurred at the first downstream driveway. Six of 18 crashes (33.3%) occurred when the upstream corner clearance was less than 250 ft.; this can be compared to 15 of 19 crashes (78.9%) that occurred when the downstream driveway corner clearance was less than 250 ft. In terms of crash severity, of the 37 crashes, none were fatal, two resulted in incapacitating injuries, eight were non-incapacitating injury crashes, and the remaining 27 were PDOs. The above statistics indicate that the downstream driveway corner clearance has a greater safety impact than the upstream driveway corner clearance. Although this result is based on a small sample, the result is consistent with the fact that vehicles exiting a downstream driveway experience reduced gaps due to dispersed platoons from the upstream roundabout. The geometry of the roundabout with a larger corner turning radii, allows vehicles to turn right at a higher speed. At corners with reduced sight distance, it further reduces the time available for driveway vehicles to complete their maneuvers.

7.2.1.3 Safety Impact of Median Openings in the Vicinity of Roundabouts. Crashes involving vehicles turning left at median openings (i.e., vehicles turning left from the main street onto a driveway and vehicles turning left from a driveway onto the main street) were relatively rare. Of the 283 roundabouts, 131 roundabouts were found to have a total of 157 median openings within 500 ft. During 2007-2011, a relatively low total of 15 crashes occurred at these 157 median openings. Of these 15 crashes, eight involved vehicles turning left from the main street onto a driveway and seven involved vehicles turning left from a driveway onto the main street.

7.2.1.4 Safety at Roundabouts that Provide Direct Access to Activity Centers. Access to major activity centers, such as big box retail stores, shopping centers, and malls, is often provided at mid-block locations on a corridor; as such, a question remains about the safety of direct access to activity centers as compared to access at mid-block locations. The safety analysis confirms that roundabouts with three or four legs with direct access to activity centers are as safe as roundabouts without direct access to activity centers. Once the number of legs increases to more than four legs, the roundabouts with direct access to the activity center are less safe.

7.2.1.5 Safety of Vulnerable Road Users, Including Pedestrians and Bicyclists. A total of 20 pedestrian crashes and 47 bicycle-vehicle crashes occurred at or near the 131 roundabouts in commercial areas, constituting less than 4% of all crashes. Of the pedestrian crashes, 18 occurred near medians, with a slightly higher rate (6.64) per 100 roundabout legs than TWLTL (5.56) and much higher than other median treatments. Because of the small sample size and the lack of good exposure data for pedestrians and bicyclists, it is difficult to generalize from the results of the safety analysis.

7.2.2 Summary of Operational Analysis

The three operational analysis issues related to access management are presented in this section. Roundabouts share these issues in common with other types of intersections. With the exception of the last issue “violation of traffic rules and its impact on the operation of roundabouts,” these concerns overlap with the issues in the safety analysis. One other issue, the spillback into a roundabout from a downstream bottleneck, was not found at the roundabouts included in the operational analysis. In cases where this occurs, it would result in a locked roundabout.

7.2.2.1 Conflicts within the Functional Area of a Roundabout. Conflict can occur in the functional area of a roundabout when driveways or other intersections are located too close to a roundabout. These conflicts can occur with a couple of types of movements, such as left-turns into driveways that are prevented or delayed because of a traffic queue on the opposing leg of the roundabout (see Figure 65). In addition, left-turning vehicles turning from a driveway onto one of the legs of a roundabout are prevented from entering the roadway, a queue, or traffic backs into another intersection because they are too closely spaced. In each case, the failure to design for the traffic queue can interfere with the operation of the entire intersection, an adjacent intersection, or both intersections, and can pose a potential safety risk, while reducing the capacity of the roundabout. The safety and operational concerns associated with conflicts within the functional area of a roundabout reinforces the importance of ensuring that intersections are not too closely spaced and that the functional area be protected to ensure the efficient movement of traffic. The challenge is that the functional area of a roundabout may be different from other intersections, especially in areas where the speed is significantly lower than most un-signalized intersections currently operate.

Figure 65-Figure 67 show examples of dealing with access to driveways at roundabouts. When left-turn access to a roundabout is designed, spill back and conflict with vehicles from the opposite direction may occur, as Figure 65 shows. One solution to this situation is to add a dedicated left turn lane in the middle with enough storage capacity (Figure 66). Another solution is to design the driveway at the exiting lane and allow right-turn access to the driveway (Figure 67).

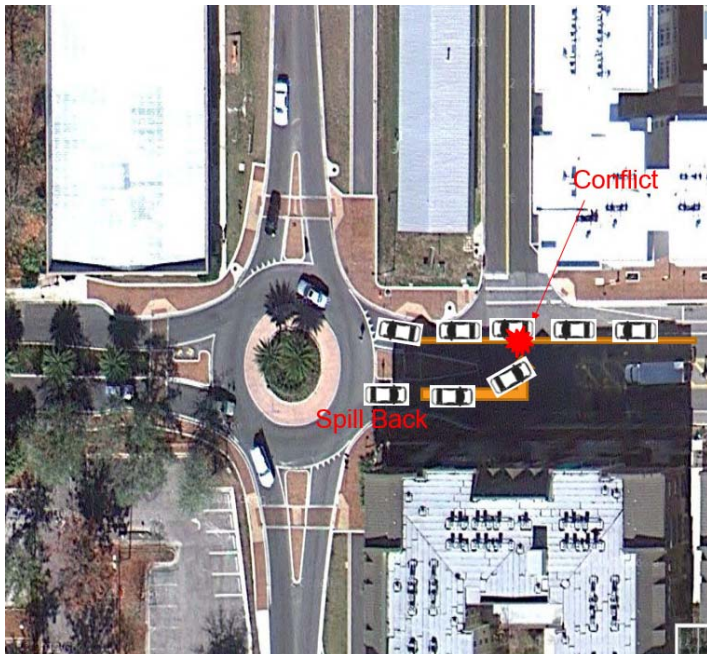

Figure 65. Conflict and Spillback associated with Left-turn Access to Driveway



Figure 66. Solution 1- Dedicated Left-turn Lane for Access to Driveway



Figure 67. Solution 2 – Right-lane Access

7.2.2.2 Conflicts at Roundabouts Involving Pedestrians and Bicyclists. From an operational perspective, locating roundabouts in an area with high pedestrian traffic can reduce the capacity of roundabouts. When a car stops for a pedestrian at a crosswalk, the queue behind the car spills back into the circulating lane, and affects the operation of the roundabout. This delay due to pedestrian movements

are not unlike the conflicts between moving vehicles and pedestrians in crosswalks at other types of intersections.

7.2.2.3 Violation of Traffic Rules and its Impact on the Operation of Roundabouts. Examples of drivers violating the rules of the road can be seen when they stop in the middle of roundabouts to either pick-up or drop-off a passenger. When the driver stops in the roundabout, the result can be a queue that causes drivers to queue inside the roundabout or change their direction to get around the stopped vehicle. Pick-ups and drop-offs are more likely to occur in areas with high pedestrian traffic or at certain activity centers. This result conflicts with the safety analysis, which reinforced the advantages of using roundabouts for access to activity centers because they reduce the challenges of access through open medians or the placement of an AWSC intersection in close proximity to the roundabout.

7.3 Roundabouts and Access Management Guidance

In this section, the national and state guidance on roundabout and access management is summarized. Then the national and state guidance on both, in combination with each other, are explored. Finally, Florida's guidance on roundabouts and access management are summarized. Following this section, the findings of the research are compared to each other to establish a basis for making recommendations.

7.3.1 Summary of National and State Guidance on Roundabouts

In this report four NCHRP reports are summarized as they relate to access management. They include: NCHRP Report 672: Roundabouts: an informational guide. Second Edition, (Rodegerdts et al., 2010), NCHRP Report 674: Crossing Solutions at Roundabouts and Channelized Turn Lanes for Pedestrians with Vision Disabilities, (Schroeder et al., 2008), NCHRP Report 572: Roundabouts in the United States. Report 572, (Rodegerdts et al., 2007), and NCHRP Synthesis 264: Modern roundabout practice in the United States, (Jacquemart, 1998). Two of these documents – NCHRP Report 672, *Roundabouts, An Informational Guide* (Rodegerdts et al., 2010) and NCHRP Report 572, *Roundabouts in the United States* (Rodegerdts et al., 2007) are of greatest relevance to this study. NCHRP Report 674 (Schroeder et al., 2008) focuses on roundabouts for pedestrians with vision disabilities. NCHRP Synthesis Report 264 (Jacquemart, 1998) is an early report on the use of roundabouts in the United States; it includes discussions of safety, capacity and delay, issues of roundabouts for various users, location criteria for roundabouts, and examples of the use of roundabouts in the United States. An additional study that is being completed under NCHRP Project 3-100 – Evaluating the Performance of Corridors with Roundabouts – will also be of relevance to this report. The contractor's report should be available within the next month.

NCHRP Report 672, *Roundabouts, An Informational Guide*, (Rodegerdts et al., 2010), is comprehensive, covering planning, operation, safety, geometric design, traffic design landscaping, and system considerations of roundabouts. In one section on planning, this document compares operational performance from the roundabouts with intersection controls, such as TWSC, AWSC, and signal control. The operation section includes the capacity and performance analysis of traffic operation, e.g. degree of saturation, delay, queue length, and field observation. Specifically for geometric design as related to access management, this document explains how to design roundabouts with: entry curves and exit curves, splitter islands, SSD, ISD, and parking and bus stop locations. In the safety section, this document reviews conflict points for different users, and common crash types in roundabouts. Signage, pavement markings, illumination, work zone traffic control, and landscaping are explored in the section on traffic design and landscaping. The last section system focuses on the following considerations related to access management: traffic signals at roundabouts, closely spaced roundabouts, roundabout interchanges, and roundabouts in an arterial network. This report is the one most frequently adopted by state DOTs, including the state of Florida, as their roundabouts design guidance documents. As is discussed below, it also includes considerations of both roundabouts and access management.

NCHRP Report 572: *Roundabouts in the United States* (Rodegerdts et al., 2007) focuses on prior research on roundabouts in the United States and describes the methods of predicting safety and operational aspects of roundabouts. This document includes four main sections: safety performance, operational performance, geometric design, and pedestrian and bicyclist observation. The findings on operational performance included entry capacity and control delay model for one-lane and multilane roundabouts; the proposed LOS criteria are similar to those at unsignalized intersections; and the draft procedures that incorporate those models into the HCM 2010. Furthermore, aspects of design that may be important to consider are: acceleration and deceleration effects on speeds, ISD, and design detail on multilane roundabouts, such as vehicle path alignment, lane width, and driver information regarding how to use lane markings.

Twenty-six states have roundabout websites with varying degrees of information. Most of these states adopt the national guidance from NCHRP Report 672: *Roundabouts, An Informational Guide*, 2nd Edition, (Rodegerdts et al., 2010). The guidance of fourteen of these states was reviewed in greater detail to understand how roundabouts guidance relates to access management. The three states that address the coordination roundabouts and access management include Wisconsin, Virginia, and Kansas; these states are profiled in greater detail in the section on roundabouts and access management, below. The state guidance in several of the fourteen states provides guidance on the use of locally developed parameters for various aspects of design and operational analysis (e.g., California for acceleration and deceleration effects; Michigan for SPFs and CMFs; and Washington for corner clearance, parallel roundabouts, U-Turns, parking and transit stops, and Wisconsin for location of driveways and site distance between users). Some states (e.g., Minnesota, Wisconsin and New Hampshire) recommend specific software for the assessment of the use of roundabouts for an intersection design.

7.3.2 Summary of National and State Guidance on Access Management

Twelve national publications that describe the advantages and disadvantages of access management and document how to implement it were identified. These documents include: A Policy on Geometric Design of Highways and Streets (Green Book), 6th Edition, AASHTO, 2011, NCHRP Synthesis 404: State of Practice in Highway Access Management (Gluck and Lorenz, 2010), NCHRP Report 548: A Guidebook for Including Access Management in Transportation Planning (Rose et al., 2005), NCHRP Synthesis 351: Access rights: a synthesis of highway practice (Huntington and Wen, 2005), NCHRP Report 524: Safety of U-turns at Unsignalized Median Openings (Potts, 2004), NCHRP Synthesis 337: Cooperative Agreements for Corridor Management (Williams, 2004), TRB Access Management Manual (TRB, 2003), NCHRP Synthesis of Highway Practice 332: Access Management on Crossroads in the Vicinity of Interchanges (Butorac and Wen, 2002), NCHRP Synthesis 304: Driveway Regulation Practices (Williams, 2002), NCHRP Report 420: Impacts of Access Management Techniques (Gluck et al., 1999), NCHRP Report 395: Capacity and Operational Effects of Midblock Left-Turn Lanes (Bonneson and McCoy, 1997), and NCHRP Report 348: Access Management Guidelines for Activity Centers (Koepke and Levinson, 1992).

Collectively, these reports document various aspects of planning for access management, including safety, capacity, economic development, and broad concepts related to the implementation of access management, cooperative agreements for corridor management, and the use of access management as a part of transportation practice. Land use and environment effects of access management include aesthetics, unification of activity centers, maintaining the capacity of available roadways, minimizing the environmental impact of individual access roads, and more efficient fuel consumption. Some of these documents focus on access management in specific contexts, such as activity centers, U-turns at unsignalized median openings, crossroads in the vicinity of interchanges, driveway regulations, and capacity and operational aspects of midblock left turns. Because some of these documents were prepared in the 1990s, they do not address roundabouts in much detail. As is described below, none of these documents, with the exception of the AASHTO Green Book (AASHTO, 2011), specifically explain the considerations for roundabouts.

Two of these documents – NCHRP Report 420, *Impacts of Access Management Techniques* (Gluck et al., 1999) and TRB *Access Management Manual* (TRB, 2003) – are useful in providing general considerations related to roundabouts and access management that could be applied to roundabouts; both of these documents are over ten years old, which may explain the lack of coverage of roundabouts. NCHRP Report 420: *Impacts of Access Management Techniques* (Gluck et al., 1999) focuses on the methods for evaluating particular access management techniques in terms of safety and traffic operations. This research identifies available techniques, and collects and analyzes the methods and data from various sources. The priorities for access management analysis are: traffic signal spacing, unsignalized access spacing, corner clearance, median alternatives, left-turn lanes, U-turns as alternatives to direct left turns, access separation at interchanges, and frontage roads.

The report reaches several conclusions. Crash rates are higher where signal density is higher, or where unsignalized intersections are more closely spaced. Safety and operations aspects are better if there is more corner clearance. Safety is also associated with raised medians. Left-turn storage lanes upgrade safety and capacity by providing spaces for turning vehicles. Indirect left-turns or U-turns may improve safety, capacity and travel time. Frontage roads along freeways may need to be allocated properly to decrease arterial left turns, weaving movements, and enhance access. They may also need to be placed far enough from the ramp to avoid conflicts. TRB's *Access Management Manual* (TRB, 2003) explores the general benefits of managing access to roadways, explains how access management can be achieved, its aspects and principles, and the roles of various institutions in access management.

Three basic steps in implementing access management to a roadway are defining access categories, establishing access management standards, and assigning categories to the roadways or roadway segments. Initial factors to be considered are the degree of roadway importance, roadway characteristics, land use and growth management objectives; and the current and predicted flows of general transit, as well as pedestrian and bicycle traffic. Four general aspects of developing access management standards include medians, degree of urbanization, speed, and safety (TRB, 2003, p. 71). Finally, the assignment of categories in roadway systems needs to take into account the following factors: the intended function of the roadway as a component of a complete transportation system network; the roadway segment's environment (rural and undeveloped, urban fringe, sub-urban, urban, and densely developed or urban core); the availability of a supporting roadway system to supply alternative access; and the desired or appropriate balance between safety and frequency of access (TRB, 2003, p. 77).

Forty-three states, including the District of Columbia, have incorporated access and/or access management into their planning and design policies. Nineteen states have access management manuals, separate from general design manuals, and eleven state DOTs mention access management or design manuals, while another sixteen DOTs have other documents with various names. Only seven states incorporate roundabouts into their access management guidance; these states are discussed below.

7.3.3 Summary of National and State Guidance on Roundabout and Access Management

Among all the national guidance documents on roundabouts and the documents on access management, only NCHRP Report 672: *Roundabouts, An Informational Guide*, Second Edition (Rodegerdts et al., 2010) refers to access management in the context of roundabouts under the general characteristics of roundabouts and as part of the geometric process (Sections 2.2.5 p. 2.9 and 6.11, pp. 6-95 to 6-98). This document reinforces the idea that “[m]ost of the principles used for access management at conventional intersections can also be applied at roundabouts.” (Rodegerdts et al., 2010, p.2-9) and “[a]ccess management at roundabouts follows many of the principles used for access management at conventional intersections” (p. 6-95). However, the difference in operational characteristics of roundabouts compared to other types of intersections may justify the difference in certain details of access management.

As a part of an overall roadway system that involves access management, the treatment of driveways and parking within the functional area of the roundabouts intersection is critical. The ability to provide public and private access points near a roundabout is influenced by a number of factors, such as the capacity of the minor movements at the access points, the need to provide left-turn storage on the major street to serve the access point, the available space between the access point and the roundabout, and sight distance needs. Figure 29, above, which was taken from NCHRP Report 672, *Roundabouts, An Informational Guide* (Rodegerdts et al., 2010) shows the typical dimensions for left-turn access near roundabouts should be about 275 ft. subject to local conditions. The functional area of about 275 ft. from the center diameter includes the distance from the center for the roundabout to the edge of the splitter island, a minimum of 50 ft. to clear the median and a minimum of 75 ft. to allow for the left turning movement in addition to the distance for maneuvering, decelerating, and queuing into the left turn lane.

A small number of states explicitly refer to access management within the context of roundabouts. Many states adopt the guidance of NCHRP 672, *Roundabouts, An Informational Guide* in their roundabout plans and, as such, adopt the unsignalized intersection spacing guidance. Some include such information in their roundabouts manuals and some in their access management manuals. From the seven states that specifically refer to access management in the context of roundabouts, two of them – Kansas and Virginia – provide significant supplemental information while adopting the national guidance. California and Iowa endorse the use of roundabouts as a part of access management but do not provide specific guidance on driveway distances and intersection spacing guidance. Michigan's *Access Management Guidebook* states (MDOT, 2008) that "Driveways need to be located a safe distance from a roundabout with adequate signage. Driveways should not be located within a roundabout" (MDOT, 2008, p. 3-29) but they do not provide specific guidance on how to accomplish this goal. Similarly, Wisconsin describes the advantage of roundabouts in the retrofit of a suburban commercial strip development in an attempt to minimize conflicts. The Wisconsin report then describes some of the factors to be considered in such retrofits (e.g., driveway consolidation, reverse frontage, coordinated U-turns and left turns, and interconnected parking lots); however, they do not provide specific guidance on the length of the functional area around roundabouts.

Both Kansas and Virginia adopt the unsignalized intersection spacing but provide additional guidance. The *Kansas Roundabout Guide: A Supplement to FHWA's Roundabouts* (Kittelton & Associates and Transystem Corporation, 2003) and *KsDOT Access Management Policy* (KsDOT, 2013) has informed and have been informed by the NCHRP 672, *Roundabouts, An Informational Guide* report. Virginia's *Access Management Design Standards for Entrances and Intersection* provides a table, shown above in Figure 29, demonstrating the spacing from other intersections and the spacing from other driveways or roundabouts. One significant difference between these sets of guidance that may affect their interpretation of the length of the functional area is that the NCHRP 672, *Roundabouts, An Informational Guide* measures the functional area from the center line of the roundabout while Kansas measures it from the end of the splitter island and Virginia measures from the outer edge of the nearest inscribed diameter, not the center line.

7.3.4 Summary of Florida's Guidance on Roundabouts and Access Management

Florida has two major documents related to access management: *FDOT Median Handbook* (2006); and *FDOT Driveway Information Guide* (2008); and four major documents that include information on roundabouts: *Florida Roundabout Guide* (FDOT, 1996); *Roundabout Justification Study* (Chapter 16 in *Manual on Uniform Traffic Studies*, FDOT, 2000); *Florida Intersection Design Guide 2013*; and *Bicycle and Pedestrian Considerations at Roundabouts* (FDOT, 2000).

FDOT Median Handbook (2006) does not explicitly mention roundabout design or access management while the *FDOT Driveway Information Guide* (2008) and the *State Highway System Access Management System and Standards* do not make any reference to roundabouts.

The *Florida Roundabout Guide* (FDOT, 1996) was published earlier than FHWA's *Roundabouts: An Informational Guide, 1st Edition* (Robinson et al., 2000) and is in the process of being replaced with more recent documents. The *Manual on Uniform Traffic Studies*, Chapter 16 – Roundabout Justification Study (2000) justifies the use of roundabouts in the State of Florida, and compares them to three other alternatives to intersection controls – traffic signals, TWSC, and AWSC. The *Florida Intersection Design Guide, 2013, For New Construction and Major Reconstruction of At-Grade Intersections on the State Highway System* emphasizes the need of considering modern roundabouts for any new road or reconstruction project as they may provide safety and operational advantages. This guide also states that Florida has officially adapted NCHRP 672, *Roundabouts, An Informational Guide* (Robinson et al., 2010) as the main guide for designing roundabouts in Florida. It describes many advantages of building roundabouts. Regarding roundabouts and access management, this document accepts that roundabouts can be used as part of an access management plan as they contribute in reducing downstream left turns, because vehicles can perform U-Turns within the roundabouts and then access an area by turning right. Also, driveways should not be allowed in the circulatory roadway unless there is enough demand to support their construction as additional legs of the roundabout.

Bicycles can access a roundabout as vehicles using the circulatory roadway or as pedestrians using sidewalks, so bicycle lanes should end at bypass ramps to allow bicycles to use the sidewalk if they prefer, always yielding to pedestrians. Pedestrian treatments at roundabouts are considered the same as in other intersection types. In case of bus routes in roads with roundabouts, bus bays should be placed carefully to avoid vehicle queues that spill back into the circulatory roadway; Bus stops located on the far side of the roundabout should have pullouts or be moved further downstream to the splitter island to avoid interrupting regular traffic. Furthermore, the Florida Intersection Design Guide adapts the SSD formula and the ISD requirements from NCHRP 672, *Roundabouts, An Informational Guide* (Equations 6-5-6-7, pp. 6-61-6-63 in Rodegerdts et al., 2010). The *Bicycle and Pedestrian Considerations at Roundabouts* (Shen et al., 2000) recommends that roundabouts be properly designed to accommodate the safety of bicyclists, pedestrians and drivers. The multi-lane roundabouts create more tension and are less safe for bicyclists and pedestrians than one-lane roundabouts. In addition to the aforementioned documents, FDOT presented a PowerPoint presentation—Roundabouts, Florida's Implementation Strategy (Prytyka and Sullivan, 2012), at the 2012 Design Training Expo where the supplemental aspects from FHWA's *Roundabouts, An Informational Guide* (Robinson et al., 2000) are captured.

7.4 Synthesis of Findings of the Research

The State of Florida is in the process of changing its guidance on the use of roundabouts on the state highway system. The change in the State's policy guidance as described in the *Florida Intersection Design Guide 2013*, *FDOT Median Handbook* (2006), *FDOT Driveway Information Guide* (2008), *State Highway System Access Management Classification System and Standards* (FDOT, 2010), and other guidance documents will define how roundabouts are implemented into cities, towns and crossroads in the state of Florida. While communities throughout Florida have significant experience with roundabouts, the level of expertise is uneven and the contexts in which the roundabouts will be implemented are diverse. The advantages of roundabouts and access management are clearly documented in the literature. Access management affects safety, operations, economic factors related to retail or commercial market and property values, land use, and the environment. Roundabouts are seen as a form of access management that has similar characteristics and operational, safety, and cost advantages compared to other types of intersections. When properly designed roundabouts and access management can enhance the aesthetic and environmental aspects of a corridor. Nonetheless the same area can experience economic decline and a loss of community livability when access management, including roundabouts, is poorly designed and implemented.

The analysis completed as a part of this research identified several areas directly related to access management and other issues that may become a part of the state's strategy to implement change in

roundabout policy. The safety analysis was completed on all roundabouts in the state and, in general, it shows a relatively low rate of crashes near roundabouts but a slightly higher rate near commercial and mixed land uses. The operational analysis was completed on a small sample of 13 roundabouts identified for their traffic volume, proximity to driveways, adjacent intersections, and adjacent land uses. Collectively, these analyses identified a couple of areas of concern. Some, such as collisions with fixed objects at night, may require design, lighting, or signage changes. Others, such as drivers stopping in the middle of roundabouts, may require design changes or driver education. Still others, such as crashes at median opening, operational concerns about left-turning vehicles, access to activity centers, and safety and operational concerns about vulnerable road users, will require greater attention to access management issues.

Roundabouts are different from other types of intersections because they can provide U-turn opportunities, allowing for a reduction of full access points along a roadway segment, while at the same time enhancing access. They have different operational characteristics – slower speeds at intersections, continuous movement of traffic, fewer conflict points between vehicles and fewer safety issues associated with left turning vehicles inside the roundabout. In turn, these operational characteristics create challenges for vulnerable roadway users and for trucks and other large vehicles. Additionally, specific operational characteristics and contextual aspects of roundabouts – new vs. retrofit, urban vs. suburban vs. rural, single vs. multi-lane vs. complex intersections (turbo, spiral or involving one or more slip lanes) affect the design characteristics of roundabouts.

This research informs us about the safety and operations of existing roundabouts in the state of Florida. However, the types of roundabouts currently in use are not representative of the types of roundabouts that are likely to be built under the new state guidelines. The sample included only four roundabouts on state highways. The roundabout corridors that were evaluated are located off the state highway system. Roundabouts built under the proposed guidelines are likely to include higher traffic volumes, more complex locations, more complex agreements between the state and local government, and in the case of retrofits, have more complex access management issues. As such, roundabout corridors, which were only examined in a limited manner, will become a more important issue in the future. This raises the question of how to design a set of recommendations that address the complexity of contexts in which roundabouts are being implemented in the state.

Recommendations of this study need to specifically address the location of driveways and intersections in close proximity to roundabouts, roundabouts near activity centers, the ISD and SSD near intersections, and the needs of both vulnerable road users and trucks in proximity to roundabouts. The first two topics are directly related to access management while the third topic is less directly related but is an important consideration in the deployment of roundabouts.

Both the safety and operational analysis identified issues related to the location of driveway and roads within close proximity to the intersection. The operational analysis identified two situations where driveway and road distances affected operations: vehicles turning left into an intersection that is located within the functional area of a roundabout, and a roundabout located too close to another intersection at an activity center. The safety analysis showed a variety of situations in which left turning vehicles, either on the leg of a roundabout and/or turning onto a driveway near a roundabout may have caused a crash. However, the crash data does not indicate serious safety issues with median openings in the vicinity of roundabouts. While losing median openings located between two adjacent roundabouts could prevent some of the median opening related crashes, the location of median openings needs to be considered within the context of overall access management in and around the roundabout.

The review of national and state guidance on roundabouts and access management, and the operational analysis of this study, suggest that roundabouts are similar to unsignalized intersections in the way that

they operate. This is confirmed by HCM 2010, p. 4-14, where it states that “[t]he operation of roundabouts is similar to that of two-way stop-controlled intersections. In roundabouts, however, entering drivers scan only one stream of traffic—the circulating stream—for an acceptable gap.” In HCM 2010, the service measure and thresholds for roundabouts have been made consistent with those for other unsignalized intersections. This is covered primarily via control delay calculation, as it is for TWSC and AWSC intersections, by adjusting for the effect of yield control. Also, “roundabouts discharge vehicles more randomly, creating small (but not necessarily usable) gaps in traffic at downstream locations” (p. 8-5). These gaps are different than signalized intersections which create vehicle platoons but similar to gaps created by other unsignalized intersections, such as AWSC intersections. As such, roundabouts may have different requirements with respect to their functional area because of differences in overall speed, acceleration, deceleration and queuing. While the access management guidance recognizes these differences, no research study has explicitly considered how contextual factors affect the functional area. The guidance on access management, which would include roundabouts, should consider the intended function of the roadway as a component of a complete transportation system network. This evaluation would include the roadway segment’s environment, whether rural and undeveloped, urban fringe, suburban, urban, and densely developed or urban core. It would also include the availability of a supporting roadway system to supply alternative access, and the desired or appropriate balance between safety and frequency of access (TRB, 2003).

Activity centers represent a specific context for roundabouts that were identified in the research but for which no clear guidance on intersection spacing and even their use can be clarified; as such, this context may require additional research. The crash data did not show increased safety hazards at roundabouts that provided direct access to activity centers. Providing direct access to activity centers through a dedicated leg is desirable to improve traffic operations on the corridor, as long as the provision does not increase the number of roundabout legs beyond the standard four legs. The operational analysis identified two situations in which roundabouts may require special design considerations to ensure the continuous and safe flow of traffic. First, if an adjacent intersection for circulating traffic is located too close to the roundabout, the operations of the roundabout and the intersection can be adversely affected. Second, if a roundabout is located near an urban activity center, where the flow of pedestrians is high, the design of the roundabout should incorporate convenient and accessible drop-off and pick-up locations in close proximity to the roundabout.

Another access management issue associated with roundabouts for which the research could not provide clear guidance relates to the SSD and the ISD. Drivers entering and exiting a roundabout need to see and react to the drivers in front of them with changes in their speed; as such the SSD and ISD are an important part of ensuring that the functional area of a roundabout is adequate to ensure the safety and efficiency for all users around roundabouts. Both of these issues were identified in the safety analysis, but the crash data shows that downstream driveway corner clearances have a greater safety impact than upstream driveway corner clearances. Longer downstream corner clearances are desirable because they provide additional time for driveway vehicles that experience reduced vehicle gaps and higher approach vehicle speed from upstream roundabouts. Although the ISD and SSD were shown to be related to the safety of the operations of the roundabout, the sample of roundabouts ($n = 37$) is relatively small. The operational analysis did not provide any additional insights into how the ISD and SSD affect the capacity and operation of the roundabouts. However, the ISD and SSD need to be considered in the design of the roundabout because they can directly affect safety and the operations of a roundabout in its functional area.

Driveways located at or near the roundabout can create conflicts with the circulatory roadway, due to acceleration and deceleration along the corridor. Yet because of the slower speeds, driveways may pose less of a challenge for access management than for other types of intersection including unsignalized intersections. However, along many parts of the state highway system, the existing driveways may pose a challenge when a roundabout is retrofitted into an urban environment. In some situations – for example, if

the driveway has low traffic volumes – access was provided prior to the installation of the roundabout. In this case, no alternative access points are available. The driveway is properly designed to allow vehicles to turn around and exit facing forward – the driveways could be located in the functional area of a roundabout if it includes adequate ISD and SSD. Where driveways are located in or near a roundabout, the design should give a clear visual indication that private driveways are adjacent to the roundabout and are not for public use.

Access management in the proximity of a roundabout is largely connected to the operation in the functional area around the roundabout, which is influenced by the ISD and the SSD, the location of driveways, and the distance to the closest intersection or roundabout. The safety analysis suggests that the downstream functional area needs to be longer for the downstream leg than for the upstream leg because drivers are likely to be decelerating as they drive towards a roundabout. Figure 29, above, shows that the typical dimensions for left-turn access near roundabouts should be a minimum of 275 ft., subject to local conditions. In addition to the distance from the center of the roundabout to its legs, this so-called functional area includes the distance from the center for the roundabout to the edge of the splitter island, a minimum of 50 ft. to clear, 75 ft. to allow for left turning movements, and 90 ft. for deceleration. NCHRP 672, *Roundabouts, An Informational Guide* is clear about the components of the functional area, but different states measure that distance differently so it is important to be clear about how to measure the distance.

7.5 Recommendations

The synthesis of the research findings suggests that, while significant research has been completed on roundabouts and on access management, additional research is needed on the combination of roundabouts and access management in different contexts and conditions. Roundabouts have generally been considered similar to unsignalized intersections, but they have different operational characteristics related to the downstream flow of vehicles, and the speed with which vehicles enter them. Roundabouts can be seen as a part of access management, like medians when they facilitate U-turns, or, as they are generally categorized, as a type of intersection. However, they have design considerations that differ from driveways and left-turn medians. Irrespective of how they are categorized, and the context in which they are implemented, roundabouts need to be designed in a manner that ensures the operational efficiency of the intersection and the safety of all users. Guidance that results in roundabouts with lengthy queuing lanes could unduly decrease the number of roundabouts that are implemented, while poorly designed guidance could create unsafe driving conditions for roadway users and reduce the access and economic viability of businesses on adjacent land.

In this section, three types of recommendations are made regarding access management around roundabouts. The first set of recommendations provides direction for the FDOT on updating their guidance on roundabouts and access management, including access management tools, the *Median Handbook*, the *Driveway Information Guide*, and the software used to analyze roundabouts. Next a set of recommendations is made for future research regarding roundabouts and access management. In particular, recommendations are made to propose an NCHRP Project on roundabouts and access management, a before-and-after study of the proposed roundabout retrofit in Downtown Sarasota, and a study to establish Florida-specific parameters to use with the HCS and other software employed to analyze the capacity of roadways on which roundabouts are proposed.

7.5.1 Recommendations for Florida's Guidance on Roundabouts and Access Management

As Florida incorporates roundabouts into its practices, all policy guidance needs to provide a consistent set of guidance on the use of roundabouts that address the diverse situations under which roundabouts are implemented. Essential to this guidance is consideration of the differences between roundabouts and other types of intersections, as well as other types of access management, such as driveways, and medians, which are discussed in later sections. The design speeds for roundabouts is significantly lower than the design

speed for unsignalized intersections, with a design speed of 20 to 30 mph and 25 to 35 mph for a single-lane and multi-lane roundabout, respectively. The guidance should address the differences in operational considerations between roundabouts and other forms of access management, and differences in the operation of the functional area, including queuing, deceleration and acceleration, accommodation of pedestrians, and other aspects of the movement of vehicles within the functional area.

The findings also identified two specific issues related to roundabouts that should be addressed in the access management guidance: the use of roundabouts to provide access to activity centers, and the accommodation of all users around a single or a corridor of roundabouts.

The Florida state guidance on access management needs to reinforce the existing process for implementing access management as roundabouts are incorporated into the access management guidance. In particular, TRB's Access Management Manual recommends three basic steps to implement access management on a roadway: defining access categories, establishing access management standards, and assigning categories to the roadways or roadway segments. Initial factors to be considered are the degree of roadway importance, roadway characteristics, land use and growth management objectives; and the current and predicted flows of general transit, as well as pedestrian and bicycle traffic. Four general aspects of developing access management standards include medians, degree of urbanization, speed, and safety (TRB, 2003, p. 71).

Finally, the assignment of categories in roadway systems needs to take into account the following factors: the intended function of the roadway as a component of a complete transportation system network; the roadway segment's environment (rural and undeveloped, urban fringe, sub-urban, urban, and densely developed or urban core); the availability of a supporting roadway system to supply alternative access; and the desired or appropriate balance between safety and frequency of access (TRB, 2003, p. 71). To the extent possible, the state should consider the use of locally developed parameters for various aspects of design and operational analysis of roundabouts. Other states have developed local parameters that relate to the influence of driver behavior as it affects capacity and operational characteristics of roundabouts.

The state has already adopted NCHRP 672, *Roundabouts, An Informational Guide* for its guidance on roundabouts, and guidance on the functional area should be included in the state guidance. Differences in the operations within the functional area should be highlighted. The guidance needs to be explicit about the definition of the functional area of a roundabout, especially if it deviates from the guidance provided in NCHRP 672, *Roundabouts, An Informational Guide*. Establishing the lengths of the functional area based upon the functional classification of the roadway is complex. While much of the guidance is built on the assumption that roundabouts operate like unsignalized intersections, the speed with which vehicles enter a roundabout is much slower than unsignalized intersections. As such, this might suggest that the functional area of a roundabout is shorter. The existing guidance for unsignalized intersections and Virginia's *Minimum Spacing Standards for Commercial Entrances, Intersections, and Crossovers*, as shown in Figure 29, should be reviewed to establish initial guidance for local governments to use as they begin to explore their options for roundabouts and access management. It is noteworthy that the intersection spacing standards for the state of Virginia, as shown in the last column in Figure 29, are closer than the intersection spacing for unsignalized intersections. Additionally, guidance on driveway and intersection spacing needs to address the fact that the speeds near roundabouts are significantly lower than the 45 mph used in the existing guidance.

7.5.1.1 Accommodation of All Users Around Roundabouts. As the state begins to implement roundabouts in a greater variety of locations, the needs of all roadway users, including bicyclists, pedestrians, and large vehicles, need to be accommodated. The findings of both the safety and operational analysis identify the need to accommodate bicyclists and pedestrians around roundabouts. Because of the lower speeds associated with roundabouts, experienced bicyclists may be able to merge with motorists as they navigate through the roundabouts. Because of the splitter island and the location of the crossing

behind the vehicle entering the roundabout, drivers may encounter less delay than vehicles at unsignalized intersections. However, because of the continuous movement through roundabouts, pedestrians, and in particular visually impaired pedestrians, are at greater risk at roundabouts than at other unsignalized intersections. Additionally, as discussed below, roundabouts present a particular challenge to pedestrians near activity centers if pick-up and drop-off is not properly handled.

While the safety and operational analysis of this study did not identify significant problems with trucks and other large vehicles, they are likely to become an issue as roundabouts are more widely used along state roadways, which can have more truck traffic. During 2007-2011, a total of 18 crashes involved heavy vehicles at the 131 commercial roundabouts. The guidance needs to be designed to accommodate trucks as a part of accommodating all users in the system. When roundabouts are implemented engineers and local officials may believe that they can remove or restrict movement at medians or other access management devices based upon the idea that left-turning movements can be accommodated at the roundabout. The U-turn alternative may increase the number of sideswipe crashes at roundabouts, especially for large vehicles.

Large trucks and buses often find it difficult to negotiate a smaller roundabout. In particular, lack of adequate lateral clearance could result in heavy vehicles sideswiping other vehicles or becoming involved in a collision with a fixed object, usually with the roundabout center island. While a single roundabout may not be able to accommodate trucks, they may be more easily accommodated along a roundabout corridor or through alternative, parallel access that allows trucks to reach commercial destinations. Furthermore, for places where the percentage of heavy vehicles is high, the design of the roundabouts should take the radius into consideration. When the lack of space prevents the installation of a large roundabout, it is recommended that other types of intersection are preferred.

7.5.1.2 Use of Roundabouts Near Major Activity Centers. The results of this research show conflicting results with respect to the use of roundabouts at the entrance to major activity centers. Access around activity centers can be complex due to the need to provide access to a variety of destinations within a short distance. Because roundabouts allow a continuous flow of traffic, they may be seen as a more efficient solution than using continuous right and left turn lanes with direction medians and other forms of access management. The safety analysis found that roundabouts with three or four legs at the entrance to activity centers are just as safe as roundabouts in other commercial locations. The operational analysis found that if a roundabout is located too close to an adjacent intersection spillover and a decrease in capacity can take place. As such, the state should consider developing guidance on the use of roundabouts at or near major activity centers. This guidance should consider whether the activity center is located in an urban, suburban or rural context; how the activity center is situated within the street network; and how trucks are accommodated in the vicinity of the roundabout. For example, can trucks have access to the stores for loading and unloading of deliveries using a parallel roadway? In an urban context where activity centers are located along a road, a roundabout could potentially provide better access to the activity center. With median closing and the use of a series of roundabouts in a corridor, safe operation and access to activity centers can both be guaranteed.

If roundabouts are not properly designed to accommodate pick-ups and drop-offs near major activity centers, drivers may need to maneuver around stopped vehicles or stop in the middle of the roundabout. Additionally, large pedestrian volumes at crosswalks within the roundabout can also cause a queue within the roundabout. The guidance for roundabout location recommends against the use of roundabouts where there are high pedestrian volumes. However, other properties of roundabouts, such as aesthetics and landscaping, may justify their usage even in locations with high pedestrian volumes. If a roundabout is used in high pedestrian areas, pedestrians could be accommodated with underpasses or overpasses, or with sidewalks further from the circulatory roadway. Regardless of whether the roundabout is located in an urban or suburban context, no significant impact on operation is shown.

7.5.1.3 Recommendations on the Software for Analysis of Roundabouts. Software for analysis of roundabouts needs to be available for a variety of applications including planning level sizing, preliminary design, analysis of pedestrian treatments, systems analysis, and public involvement. Generally, these needs can be addressed with HCS. Other deterministic software can conduct the planning-level and preliminary design review, while simulation software can be used for the systems analysis, public involvement and analysis of pedestrian treatments.

Deterministic software, such as HCS, Synchro, SIDRA, RODEL and ARCADY, can perform queuing analysis and provide useful information related to access management, especially for placing driveways. Simulation software, such as VISSIM, can be used to evaluate the operation of roundabouts and the interaction between traffic flows at roundabouts and adjacent driveways by conducting microscopic analysis. It is clear from this analysis that deterministic software can provide guidance on where the driveway should be placed before the construction of intersections, while simulation can be used to evaluate the impact of driveway and other access management issues on roundabout operation.

The new version of HCS 2010 provides a viable tool to conduct queuing analysis for roundabout, which can be used to determine the location of access point and the length of functional area. CORSIM, which is used for other applications in Florida, when compared to other simulation software packages, requires some modification in order to accurately replicate roundabout operations. Roundabouts should be made available in CORSIM by allowing multiple nodes to be grouped together as one roundabout, and follow up time and critical gap should be made approach-based.

7.5.2 Recommendations for Additional Research

While the number of roundabouts has increased significantly over the past couple of decades, research has not kept up with our understanding of the differences between the safety and operational characteristics of roundabouts as they have been implemented in a diversity of situations. NCHRP 672, *Roundabouts, An Informational Guide* provides guidance on a variety of aspects of the analysis and use of roundabouts and it characterizes the similarities between roundabouts and other types of intersections. However, it does not provide detailed guidance on roundabouts and access management. The FDOT should conduct its own research and work with AASHTO and other partners to ensure that guidance, including roundabouts as a component of access management, be incorporated into practice. In this section, three separate research initiatives are identified based upon the research conducted in this study including: national research on roundabouts and access management, a before-and-after study of proposed roundabouts in the US 41 corridor in Sarasota, and studies on the development of local variables for parameters in the analysis tools for assessment of roundabouts. The first research would be proposed for a national study, while the last two would be recommended for FDOT funding.

7.5.2.1 National Research Effort on Roundabouts and Access Management

Throughout this research it has become increasingly clear that little research has been conducted on roundabouts in combination with other forms of access management and roundabouts as a form of access management. Roundabouts can be seen as a form of access management because they can accommodate left-turns and allow the removal of directional left-turn lanes, yet they function as intersections. The differences in safety and operational characteristics from other types of access management and other intersections means that the site distances, stopping distances, functional area characteristics, and intersection and driveway spacing may be different for roundabouts. Furthermore, the use of roundabouts in a variety of transportation and land use contexts may mean that these factors differ by context. While NCHRP 672, *Roundabouts, An Informational Guide* provides a great start on this research, a project is needed that specifically focuses on guidance on access management for major arterials and other similar roadways found in the state highway system.

7.5.2.2 Before-and-After Study of the Sarasota Roundabouts

Roundabouts and Access Management

Another area where further research is needed is related to understanding the differences in operational characteristics between corridors using roundabouts and other standard intersections. The contractor's report on NCHRP 3-100, which evaluates the use of roundabouts along corridors, is likely to increase our understanding of these differences. However, this study is a cross-sectional study, which may not have a complete set of operational data that allows for a comprehensive understanding of these differences. FDOT has a unique opportunity to complete such a study on the US 41 corridor in Sarasota where two roundabouts are proposed in a portion of the downtown area. This project is currently scheduled in the later years of the regional Transportation Improvement Program (TIP). As such, the FDOT has the opportunity to complete a before-and-after study by collecting the before data within the next two years and then at two points after when the project is completed. A second set of data could be collected to understand the adjustment of roadway users to the new roundabout and other access management features, while the third set of data could be collected after drivers have adjusted to the change in the corridor. To complete such an evaluation would require the collection of the following types of data:

- Existing geometry (number of lanes, types of lanes, etc.). FDOT should be able to provide as-built plans. These can then be verified through field observation.
- Travel time. This can be verified using an instrumented vehicle making numerous runs along the corridor. Each run would be video-recorded so that the researchers can accurately identify sources of variation in the travel times.
- Traffic volumes. This data could come from stationary video cameras or existing FDOT sensor infrastructure, if it exists.
- Turning movement percentages (right, through, left, U-turn). Again, this could come from stationary video cameras or existing FDOT sensor infrastructure, if it exists.
- Intersection approach leg average queue lengths (this can be estimated from video recordings).
- Signal timings (assuming there are currently signalized intersections along this corridor). These data should be able to be provided by FDOT. They can be verified through field observation.

7.5.2.3 Focused Studies on State-specific locations guidance

A major challenge with the use of national guidance, or guidance from other states, is that drivers in Florida may respond differently to different forms of access management, they may have different reaction times and they may drive closer or further from other drivers as they enter intersections and roundabouts. The roundabouts guidance in several states provides documentation of use of locally-developed parameters for various aspects of design and operational analysis (e.g., California for acceleration and deceleration effects; Michigan for SPFs and CMFs; and Washington for corner clearance, parallel roundabouts, U-Turns, parking and transit stops, and Wisconsin for location of driveways and site distance between users). These factors may influence the calculation of the entry flow rate, conflicting flow rate and exit flow rate of roundabouts. To the extent that Florida drivers behave differently than drivers in other states, the FDOT should fund research to justify the use of different parameters for software and other analytical tools for planning-level design, preliminary design, analysis of pedestrian treatments, and systems analysis.

Chapter Eight: Conclusions

This FDOT research project focused on providing advice on how to evaluate the use of roundabouts as a form of access management and consequently on what should be included in the FDOT's *Median Handbook*, and *Driveway Information Guide*. In order to accomplish this goal it is important to understand the connection between roundabouts and access management and other forms of traffic control. Therefore, this project included three primary components: a review and assessment of national and state guidance related to roundabouts and access management; a safety analysis of all 283 roundabouts in Florida; and an operational analysis of selected roundabouts. This chapter summarizes the conclusions of this research effort.

8.1 Conclusions of the Review of National and State Guidance

The review of national guidance on roundabout and access management showed that there are only five national reports that refer to roundabouts: AASHTO Green Book (2011), NCHRP Report 672, NCHRP Report 572, NCHRP Report 674, and NCHRP Synthesis 264, of which only the former three are relevant to this study. NCHRP Report 672, *Roundabouts, An Informational Guide* refers to access management in the context of roundabouts and reinforces the idea that many of the access management principles applied to conventional intersections can be applied to roundabouts as well. The AASHTO Green Book (2011) explains access management considerations for roundabouts. NCHRP Project 3-100, currently in progress, evaluates the Performance of Corridors with Roundabouts and will soon produce another national report which will be relevant to this project.

Regarding state guidance on roundabouts, from the fifty states and the District of Columbia, twenty-six states have websites on roundabouts with varying degrees of information. Most of these states adopt the national guidance from NCHRP Report 672, *Roundabouts, An Informational Guide* (Rodegerdts et al., 2010). In fourteen states guidance on the use of locally developed parameters for various aspects of design and operational analysis is provided. Minnesota, Wisconsin and New Hampshire recommend specific software for the assessment of the use of roundabouts for an intersection design. Three other states, Wisconsin, Virginia, and Kansas, address the coordination of roundabouts and access management. Regarding access management guidance, forty-three states have incorporated access and/or access management into their planning and design policies. Nineteen states have access management manuals, separate from general design manuals and eleven state DOTs mention access management or design manuals. Another sixteen DOTs have other documents with various names. However, only seven states incorporate roundabouts into their access management guidance: Kansas, Virginia, California, Iowa, Michigan, Wisconsin, and Washington. Generally, when it comes to roundabouts and access management, only Kansas and Virginia provide significant supplemental information to NCHRP 672, *Roundabouts, An Informational Guide*, while most of the other states simply adopted the guidance without supplementation.

Florida has three major documents related to access management. The FDOT *Median Handbook* (2006) addresses some design considerations related to roundabouts but it does not provide information about roundabout design or access management. The other two documents do not refer to roundabouts.

8.2 Conclusions About Safety Analysis of Roundabouts in Florida

During 2007-2011, a total of 2,941 crashes were found to have occurred within 500 ft. of the 283 roundabouts. Police reports of these crashes were downloaded and reviewed. Crash locations of these 2,941 crashes were manually verified and the incorrect locations were corrected. Intersection-related crashes and those that did not occur on the roundabouts and their approach legs were excluded. Finally, a total of 1,882 crashes that occurred within 500 ft. of the 283 roundabouts were included in the analysis.

The following potential safety concerns associated with roundabouts in commercial areas were investigated:

- Impact of driveway corner clearances on roundabout safety.
- Safety impact of median openings in the vicinity of roundabouts.
- Safety at roundabouts that provide direct access to activity centers.
- Safety of vulnerable road users including pedestrians and bicyclists.

Based on the results from the safety analysis, the following general recommendations related to the access features in the vicinity of roundabouts are made:

- Crash data show that downstream driveway corner clearances have a greater safety impact than upstream driveway corner clearances. Longer downstream corner clearances are desirable to provide additional time for driveway vehicles that experience reduced vehicle gaps and higher approach vehicle speed from upstream roundabouts.
- Crash data did not indicate serious safety issues with median openings in the vicinity of roundabouts. However, closing median openings located between two adjacent roundabouts could prevent some of the median opening related crashes and is desirable if the corridor is designed to serve low heavy vehicle volumes or if the roundabouts are sufficiently large to safely accommodate U-turns by heavy vehicles.
- Crash data did not show an increased safety hazard at roundabouts that provide direct access to activity centers. Providing direct access to activity centers through a dedicated leg is desirable to improve traffic operations on the corridor if the provision does not increase the number of roundabout legs to beyond the standard four.

8.3 Conclusions About Operational Analysis of Roundabouts in Florida

The conclusions from the operations analysis of roundabouts in Florida are described in this paragraph. The roundabouts' operational analysis conducted in Florida showed that conflicts can occur in the functional area of a roundabout when driveways or other intersections are located too close to a roundabout. The functional area of a roundabout may be different from conventional intersections, especially in cases where the speed is significantly lower than most un-signalized intersections currently operate. In order to avoid such conflicts, geometric design should take into consideration the traffic queue that could be develop during roundabout operations as they can affect processes within the roundabout or with the surrounding intersections. During the operational analysis, high pedestrian and bicycles volumes can affect the capacity and the effective operations of roundabouts.

The operational analysis also indicated erroneous driver behavior such as stopping in the middle of the intersection to pick up or drop off pedestrians, causing queues which usually happen in areas with high pedestrian and bicycle volumes. This conflicts with the safety analysis, which reinforced the advantages of using roundabouts for access to activity centers because they reduced the challenges of access through open medians or the placement of an AWSC intersection in close proximity to the roundabout. Another concern is spillback into the roundabout from a downstream bottleneck, which would result in completely locking the roundabout.

8.4 Final Remarks

As Florida starts incorporating roundabouts into its practices more often, consistent guidance on the use of roundabouts that address the diverse situations under which they are implemented should be provided. Essential to this guidance is consideration of the differences between roundabouts and other types of intersections and other types of access management, such as driveways, and medians. Roundabouts have

generally been considered similar to unsignalized intersections but they have different operational characteristics related to the downstream flow of vehicles, and the speed with which vehicles enter them. Irrespective of how they are considered, and the context in which they are implemented, roundabouts need to be designed in a manner that ensures their operational efficiency and the safety of all users. The findings of both the safety and operational analysis identify the need to accommodate bicyclists and pedestrians around roundabouts because pedestrians, and in particular, visually impaired pedestrians, are at greater risk at roundabout than at other unsignalized intersections due to the continuous movement through them. Additionally, roundabouts present a particular challenge to pedestrians near activity centers if pick-ups and drop-offs are not properly handled.

The results of this research show conflicting results with respect to the use of roundabouts at the entrance to major activity centers. Roundabouts allow a continuous traffic flow so they may be seen as a more efficient solution than using continuous right and left turn lanes with direction medians and other forms of access management. The safety analysis found that roundabouts with three or four legs at the entrance to activity centers are just as safe as roundabouts in other commercial locations. However, the operational analysis found that if a roundabout is located too close to an adjacent intersection, spillover and a decrease in capacity may happen. As such, the state should consider developing guidance on the use of roundabouts at or near major activity centers and consider the context where the activity center is located, how the activity center is situated within the street network, and if trucks and delivery vehicles are properly accommodated in the vicinity of the roundabout. If a roundabout is constructed in high pedestrian areas, pedestrians could be accommodated with underpasses or overpasses or with sidewalks further from the circulatory roadway. While the safety and operational analysis of this study did not identify significant problems with trucks and other large vehicles, they are likely to become an issue as roundabouts are more widely used along state roadways. These can have more truck traffic and large trucks and buses may find it difficult to negotiate a small roundabout. Therefore, the roundabout design should account for adequate lateral clearance and a larger radius.

Florida has already adopted NCHRP 672, *Roundabouts, An Informational Guide* but to the extent possible, the state should consider the use of locally developed parameters for various aspects of design and operational analysis of roundabouts. Other states have developed local parameters that relate to the influence of driver behavior as it affects capacity and operational characteristics of roundabouts. Differences in the operations within the functional area should be highlighted. The guidance needs to be explicit about the definition of the functional area of a roundabout especially if it is different from the one specified in NCHRP 672, *Roundabouts, An Informational Guide*.

In order to estimate and examine the effects and operations of a roundabout, simulation and analysis software should be available. So far, HCS and other deterministic software such as HCS, Synchro, SIDRA, RODER and ARCADY can conduct the planning-level, preliminary design analysis, queuing analysis and provide information related to access management and location of driveways. Simulation software such as VISSIM can be used for the traffic network analysis, public involvement and pedestrian treatments analysis. Not all the simulation programs can adequately simulate real world applications so the planners and engineering should pay attention to which software they use and which parameters they consider in the analysis of roundabouts or driveway placement in the vicinity of roundabouts.

Finally, this research did not show significant impacts of the roundabout location, whether in an urban or suburban context, on traffic operations.

8.5 Additional Research Needs

The research findings of this project suggest that while some research has been completed on roundabouts, additional research is needed on the combination of roundabouts and access management in different

contexts and conditions. NCHRP 672, Roundabouts, An Informational Guide, the main national guidebook on roundabouts, does not provide detailed guidance on roundabouts and access management. The FDOT should conduct its own research and work with AASHTO and other partners to ensure that guidance, including roundabouts as a component of access management, is incorporated into practice. The development of local variables for parameters in the analysis tools for assessment of roundabouts is necessary because using national guidance or guidance from other states may not capture the way in which drivers in Florida respond to different forms of access management. They may have different reaction times or drive closer or further from other drivers as they enter intersections and roundabouts. The roundabouts guidance in several states provides documentation of use for locally-developed parameters for various aspects of design and operational analysis (e.g., California for acceleration and deceleration effects; Michigan for SPFs and CMFs; Washington for corner clearance, parallel roundabouts, U-Turns, parking and transit stops; and Wisconsin for location of driveways and site distance between users). These factors may influence the calculation of the entry flow rate, conflicting flow rate and exit flow rate of roundabouts. To the extent that Florida drivers behave differently than drivers in other states, FDOT should fund research to justify the use of different parameters for the software and other analytical tools for planning-level design, preliminary design, analysis of pedestrian treatments, and systems analysis.

Also, in order to enhance understanding of the effects of roundabouts on traffic conditions, safety, and traffic network operations, there is a need to conduct national research on roundabouts and access management that specifically focuses on access management for major arterials and other similar roadways found on the state highway system.

Throughout this research it has become increasingly clear that, while much research has been conducted about roundabouts and about access management, little research has been conducted on roundabouts in combination with other forms of access management and roundabouts as a form of access management. Roundabouts can be seen as a form of access management because they can accommodate left-turns and allow the removal of directional left-turn lanes, yet they function as intersections. The differences in their safety and operational characteristics from other types of access management and other intersections means that site distances, stopping distances, functional area characteristics, and intersection and driveway spacing may be different for roundabouts. Furthermore, the use of roundabouts in a variety of transportation and land use contexts may mean that these factors differ by context. Additionally, there is a lack of research on access management and roundabouts or a series of roundabouts in corridors. NCHRP 3-100, which evaluates the use of roundabouts along corridors, is on progress and it is likely to give some insight of the differences between roundabouts and conventional intersections. However, this study may not have a complete set of operational data that can allow for a more comprehensive understanding of these differences. Recently, the city of Sarasota proposed a series of roundabouts on US 41. Conducting a before-and-after study there would give a better understanding of the operational and safety characteristics of corridors with roundabouts instead of conventional intersections. Therefore, FDOT has a unique opportunity to complete a real data study on the US 41 corridor in Sarasota where two roundabouts are proposed in a portion of the downtown.

References Cited

- Akcelik, R., Chung, E., & Besley, M. (1997, July). Analysis of roundabout performance by modelling approach flow interactions. In *Proceedings of the Third International Symposium on Intersections Without Traffic Signals* (pp. 15-25).
- Akçelik, R. (2004). A roundabout case study comparing capacity estimates from alternative analytical models. Presented at the Second Urban Street Symposium, Anaheim, CA, 2004.
- Akçelik, R. (2011). An assessment of the Highway Capacity Manual 2010 roundabout capacity model. In *TRB International Roundabout Conference, Carmel, Indiana, USA*.
- Akcelik & Associates. (2014). About Akcelik & Associates. Retrieved from: <http://www.sidrasolutions.com/Company/About>
- Al-Ghandour, M., Schroeder, B., Rasdorf, W., & Williams, B. (2012). Delay analysis of single-lane roundabout with a slip lane under varying exit types, experimental balanced traffic volumes, and pedestrians, using microsimulation. *Transportation Research Record: Journal of the Transportation Research Board*, 2312(1), 76-85.
- Al-Masaeid, H. R., & Faddah, M. Z. (1997). Capacity of roundabouts in Jordan. *Transportation Research Record: Journal of the Transportation Research Board*, 1572(1), 76-85.
- Al-Masaeid, H. R. (1999). Capacity and performance of roundabouts. *Canadian Journal of Civil Engineering*, 26(5), 597-605.
- American Association of State Highway Transportation Officials (AASHTO) (2011). *A Policy on the Geometric Design of Highways and Streets*. American Association of State Highway and Transportation Officials, Washington, DC, 1, 990.
- Angelastro, M., McFadden, J., & Mehta, Y. (2012). Evaluation of sight distance and crash frequency at roundabouts in the United States. In *Transportation Research Board 91st Annual Meeting* (No. 12-2412).
- Ariniello, A. J. (2004, December). Are Roundabouts Good for Business? In *Transportation Research Board National Roundabout Conference, Vail Colorado*.
- Arizona Department of Transportation (AzDOT). (2012). *Roadway Design Guidelines*, Section 403.2.
- Arndt, O. K., & Troutbeck, R. J. (1998). *Relationship between roundabout geometry and accident rates* (No. E-C003).
- Ashmead, D. H., Guth, D., Wall, R. S., Long, R. G., & Ponchillia, P. E. (2005). Street crossing by sighted and blind pedestrians at a modern roundabout. *Journal of Transportation Engineering*, 131(11), 812-821.
- Aty, M. A., & Hosni, Y. (2001). *State-of-the-Art Report On: Roundabouts Design, Modeling and Simulation* (No. Final Report). Retrieved from <http://ntl.bts.gov/lib/17000/17700/17782/PB2001104294.pdf>
- Bagdade, J., Persaud, B. N., Mcintosh, K., Yassin, J., Lyon, C. A., Redinger, C., Whitten, J., & Butch, W. A. (2011). *Evaluating the Performance and Safety Effectiveness of Roundabouts* (No. RC-1566).
- Bansen, J., & Sullivan, F. (2013, June) Modern Roundabouts in Florida. Presentation made at Florida Design Training Expo, Orlando, FL.
- Bared, J., & Edara, P. K. (2005, May). Simulated capacity of roundabouts and impact of roundabout within a progressed signalized road. In *National Roundabout Conference: 2005 Proceedings. Transportation Research Board of the National Academies, Vail, USA*.
- Berthume, A., & Knodler Jr, M. A. (2013). Hazardous Bicycle Maneuvers at Single-Lane Roundabouts in Massachusetts: A Conflict and Events Study. In *Transportation Research Board 92nd Annual Meeting* (No. 13-4216).
- Bie, J., Lo, H.K., Wong, S., & Hung, W. (2005). Safety analysis of traffic roundabout: conventional versus Alberta-type markings. *Journal of the Eastern Asia Society for Transportation Studies*, 6, 3309-3324.

- Bonneson, J. A. and McCoy, P. T. (1997) Capacity and Operational Effects of Midblock Left-Turn Lanes NCHRP Report 395. Washington, DC: Transportation Research Board. Retrieved from http://onlinepubs.trb.org/onlinepubs/nchrp/nchrp_rpt_395.pdf
- Brown, M. (1995). *The design of roundabouts*. Transport Research Laboratory, London.
- Butorac, M. A. and Wen. J. C. (2002). Access Management on Crossroads in the Vicinity of Interchanges, A Synthesis of Highway Practice. NCHRP Synthesis Report 332, Washington, DC: Transportation Research Board. Retrieved from http://onlinepubs.trb.org/onlinepubs/nchrp/nchrp_syn_332.pdf
- California Department of Transportation (Caltrans). (2007). Highway Design Manual.
- Chen, Y., Persaud, B., & Lyon, C. (2011). Effect of Speed on Roundabout Safety Performance: Implications for Use of Speed as Surrogate Measure. In *Transportation Research Board 90th Annual Meeting* (No. 11-2846).
- Churchill, T., Stipdonk, H., & Bijleveld, F. D. (2010). *Effects of roundabouts on road casualties in the Netherlands* (Vol. 2010, No. 21). Institute for Road Safety Research.
- Dabbour, E., & Easa, S. M. (2008). Evaluation of safety and operational impacts of bicycle bypass lanes at modern roundabouts. *Canadian Journal of Civil Engineering*, 35(10), 1025-1032.
- Daniels, S., & Wets, G. (2005). Traffic safety effects on roundabouts: a review with emphasis on bicyclist's safety.
- Daniels, S., Nuyts, E., & Wets, G. (2008). The effects of roundabouts on traffic safety for bicyclists: an observational study. *Accident Analysis & Prevention*, 40(2), 518-526.
- Daniels, S., Brijs, T., Nuyts, E., & Wets, G. (2010). Externality of risk and crash severity at roundabouts. *Accident Analysis & Prevention*, 42(6), 1966-1973.
- Daniels, S., Brijs, T., Nuyts, E., & Wets, G. (2011). Extended prediction models for crashes at roundabouts. *Safety science*, 49(2), 198-207.
- De Brabander, B., Nuyts, E., & Vereeck, L. (2005). Road safety effects of roundabouts in Flanders. *Journal of Safety Research*, 36(3), 289-296.
- De Brabander, B., & Vereeck, L. (2007). Safety Effects of Roundabouts in Flanders: Signal type, speed limits and vulnerable road users. *Accident Analysis & Prevention*, 39(3), 591-599.
- Demosthenes, P. (2007, Oct 18). Why Manage Access to the State Highway System. PowerPoint Presentation at the Division of Research and Innovation Caltrans. Retrieved from http://www.dot.ca.gov/researchconn/past_speakers/MrDemosthenes_1/demosthenes_accessmgt_caltrans_oct18_07wtext.pdf
- Dixon, K., & Zheng, J. (2013). *Developing Safety Performance Measures for Roundabout Applications in the State of Oregon* (No. FHWA-OR-RD-13-08).
- Elias, A. (2009). *Roundabout modeling in CORSIM*. MS Thesis. University of Florida.
- Elvik, R. (2003). Effects on road safety of converting intersections to roundabouts: review of evidence from non-US studies. Transportation Research Record: Journal of the Transportation Research Board, 1847(1), 1-10.
- Federal Highway Administration (FHWA). (2006). Roundabouts: Technical Summary. Retrieved from <http://safety.fhwa.dot.gov/intersection/roundabouts/fhwasa10006/fhwasa10006.pdf>
- Federal Highway Administration (FHWA). (2011). Public Roads. Retrieved from <http://www.fhwa.dot.gov/publications/publicroads/11septoct/02.cfm>
- Federal Highway Administration (FHWA) (2013). FHWA Office of Safety Roundabout Outreach and Education Toolbox, Retrieved from <http://safety.fhwa.dot.gov/intersection/roundabouts/roundabouttoolbox/>

- Fisk, C. S. (1991). Traffic performance analysis at roundabouts. *Transportation Research Part B: Methodological*, 25(2), 89-102.
- Flannery, A., & Datta, T. K. (1996). Modern roundabouts and traffic crash experience in United States. *Transportation Research Record: Journal of the Transportation Research Board*, 1553(1), 103-109.
- Flannery, A., & Datta, T. (1997). Operational performance measures of American roundabouts. *Transportation Research Record: Journal of the Transportation Research Board*, 1572(1), 68-75.
- Flannery, A., Elefteriadou, L., Koza, P., & McFadden, J. (1998). Safety, delay, and capacity of single-lane roundabouts in the United States. *Transportation Research Record: Journal of the Transportation Research Board*, 1646(1), 63-70.
- Flannery, A. (2001). Geometric design and safety aspects of roundabouts. *Transportation Research Record: Journal of the Transportation Research Board*, 1751(1), 76-81.
- Florida Department of Transportation (FDOT). (1996). *Florida Roundabout Guide*. Tallahassee, Florida. Retrieved from http://www.dot.state.fl.us/trafficoperations/doc_library/pdf/roundabout_guide8_07.pdf
- Florida Department of Transportation (FDOT). (2000). *Manual on Uniform Traffic Studies, Topic No. 750-020-007, Roundabout Justification Study*. Tallahassee, Florida: FDOT. Retrieved from <http://www.dot.state.fl.us/trafficoperations/Operations/Studies/MUTS/Chapter16.pdf>
- Florida Department of Transportation (FDOT). (2006). *Median Handbook*. Tallahassee, Florida. Retrieved from <http://www.dot.state.fl.us/planning/systems/programs/sm/accman/pdfs/mhb06b>.
- Florida Department of Transportation (FDOT) (2007). Florida Intersection Design Guide. For New Construction and Major Reconstruction of At-Grade Intersections on the State Highway System. Retrieved from <http://www.dot.state.fl.us/rddesign/FIDG-Manual/FIDG2007.pdf>
- Florida Department of Transportation (FDOT). (2008). *Driveway Information Guide*. Tallahassee, Florida. Retrieved from <http://www.dot.state.fl.us/planning/systems/programs/sm/accman/pdfs/driveway2008.pdf>
- Florida Department of Transportation (FDOT) Roadway Design Office (2010) Design Standards for Design, Construction, Maintenance and Utility Operations on the State Highway System, Standard Index 515 (Driveways). Retrieved from <http://www.dot.state.fl.us/rddesign/DS/14/IDx/00515.pdf>
- Florida Department of Transportation (FDOT). (2014). Systems Planning Documents: Access Management. Retrieved <http://www.dot.state.fl.us/planning/systems/documents/sm/default.shtm#access>
- Fortuijn, L.G.H. (2009). Turbo Roundabouts: Design Principles and Safety Performance. *Transportation Research Record: Journal of the Transportation Research Board*, 2096, 16-24.
- Frawley, W. E., & Eisele, W. L. (2005). *Access Management Guidebook Texas*. Texas Transportation Institute, Texas A & M University System.
- Furtado, G. (2004). Accommodating vulnerable road users in roundabout design. In *2004 TAC Annual Conference*.
- Gluck, J. S., Levinson, H. S., & Stover, V. G. (1999). *Impacts of access management techniques* (No. 420). Transportation Research Board. Washington D.C.
- Gluck, J. S. & Lorenz, M. R. (2010). NCHRP Synthesis 404: State of the Practice in Highway Access Management. Washington, DC: Transportation Research Board. Retrieved from http://onlinepubs.trb.org/onlinepubs/nchrp/nchrp_syn_404.pdf
- Gross, F., Lyon, C., Persaud, B., & Srinivasan, R. (2013). Safety effectiveness of converting signalized intersections to roundabouts. *Accident Analysis & Prevention*, 50, 234-241.

- Hagring, O., Roupail, N. M., & Sørensen, H. A. (2003). Comparison of capacity models for two-lane roundabouts. *Transportation Research Record: Journal of the Transportation Research Board*, 1852(1), 114-123.
- Hallmark, S. L., Fitzsimmons, E. J., Isebrands, H. N., & Giese, K. L. (2010). Roundabouts in Signalized Corridors. *Transportation Research Record: Journal of the Transportation Research Board*, 2182(1), 139-147.
- Hallmark, S. L., & Isebrands, H. (2008). *Planning-level Guidelines for Modern Roundabouts*. Center for Transportation Research and Education, Iowa State University.
- Harkey, D. L., & Carter, D. L. (2006). Observational analysis of pedestrian, bicyclist, and motorist behaviors at roundabouts in the United States. *Transportation Research Record: Journal of the Transportation Research Board*, 1982(1), 155-165.
- Hels, T., & Orozova-Bekkevold, I. (2007). The effect of roundabout design features on cyclist accident rate. *Accident Analysis & Prevention*, 39(2), 300-307.
- Huntington, D. & Wen, J. (2005). *Synthesis 351: Access Rights*. Transportation Research Board; National Cooperative Highway Research Program Synthesis Program (NCHRP SYN); NCHRP The National Academies Press: Washington, DC. Retrieved from http://www.nap.edu/catalog.php?record_id=13557
- Hyden, C., & Varhelyi, A. (2000). The effects on safety, time consumption and environment of large scale use of roundabouts in an urban area: a case study. *Accident Analysis & Prevention*, 32(1), 11-23.
- Indiana Department of Transportation (IndOT). (2006, revised 2009). *Access Management Guide*. Retrieved from www.in.gov/indot/files/guide_total.pdf
- Inman, V. W., Davis, G. W., & Sauerburger, D. (2005, May). Roundabout access for visually impaired pedestrians: Evaluation of a yielding vehicle alerting system for double-lane roundabouts. In *Proceedings, National Roundabout Conference, Vail, CO*.
- Inman, V. W., Davis, G. W., & Sauerburger, D. (2006a). *Pedestrian access to roundabouts: Assessment of motorists' yielding to visually impaired pedestrians and potential treatments to improve access* (No. FHWA-HRT-05-080). Retrieved from <http://www.fhwa.dot.gov/publications/research/safety/pedbike/05080/>
- Inman, V. W., Katz, B. J., & Hanscom, F. R. (2006b). Navigation signing for roundabouts. *Transportation Research Record: Journal of the Transportation Research Board*, 1973(1), 18-26.
- Iowa Department of Transportation (IowaDOT). (2009, revised in 2010). *Design Manual Chapter 6 Geometric Design, 6A-3 Modern Roundabout-General Guidance*. Retrieved from www.iowadot.gov/design/dmanual/06a-03.pdf
- Iowa Department of Transportation (IowaDOT). (2012). *Iowa Primary Highway Access Management Policy*. Retrieved from <http://www.iowadot.gov/traffic/pdfs/AccessPolicy.pdf>
- Isaacs, B., & Barrett, J. P. (2003). Use of Roundabouts in an Urban Setting. In *2nd Urban Street Symposium: Uptown, Downtown, or Small Town: Designing Urban Streets That Work*.
- Isebrands, H. N. (2009a). Roundabouts and signals: harmony even with increasing traffic volumes. *ITE Journal*, 79(2).
- Isebrands, H. (2009b). Crash analysis of roundabouts at high-speed rural intersections. *Transportation Research Record: Journal of the Transportation Research Board*, 2096(1), 1-7.
- Isebrands, H., & Hallmark, S. (2012). Statistical analysis and development of crash prediction model for roundabouts on high-speed rural roadways. *Transportation Research Record: Journal of the Transportation Research Board*, 2312(1), 3-13.
- Jacquemart, G. (1998). *Modern roundabout practice in the United States* (No. Project 20-5 FY 1996). Retrieved from http://onlinepubs.trb.org/onlinepubs/nchrp/nchrp_syn_264.pdf

- Jasper, J.D. (2010). Director Division of Highway Design. *Design Memorandum No. 01-10, Design Guidance for Roundabout Intersections*. Retrieved from <http://transportation.ky.gov/Congestion-Toolbox/Documents/KYTC%20Roundabout%20Policy.pdf>
- Jensen, S. U., & Apes, T. (2013). Safety Effects of Converting Intersections to Roundabouts. In *Transportation Research Board 92nd Annual Meeting* (No. 13-1319).
- Johnson, M. T., & Isebrands, H. N. (2008). Access management considerations for high capacity multi-lane roundabout design and implementation. In *8th National Conference on Access Management*.
- Kansas Department of Transportation (2013, January). *KDOT Access Management Policy*. Retrieved from: http://www.ksdot.org/accessmanagement/Access_Management_Policy_Jan2013.pdf
- Kentucky Transportation Cabinet (KYTC). (2008). Access Management Implementation Report. Retrieved from transportation.ky.gov/Congestion-Toolbox/Documents/Access%20Management%20Implementation%20Report%202008.pdf
- Kentucky Transportation Cabinet (KYTC). (2010). Design Guidance for Roundabout Intersections. Retrieved from transportation.ky.gov/Congestion-Toolbox/Documents/KYTC%20Roundabout%20Policy.pdf
- Kittelson & Associates, Inc. (2013). Evaluating the Performance of Corridors with Roundabouts. Project No. 03-100.
- Kittelson & Associates, Inc. & TranSystem Corporation. (2003). *Kansas Roundabout Guide, A Supplement to FHWA's Roundabouts: An Informational Guide*. Kansas Department of Transportation. Retrieved from www.ksdot.org/burtrafficeeng/Roundabouts/Roundabout_Guide/RoundaboutGuide.asp
- Koepke, F. J., & Levinson, H. S. (1992). Access management guidelines for activity centers. Washington, D.C. Transportation Research Board.
- Layton, R. (2012). *Interchange Access Management*. Oregon State University; Corvallis, OR.
- Lee, J. C., Robinson, B., Kidd, B. D., & Scarborough, W. (2003). *Roundabouts: An Arizona case study and design guidelines* (No. FHWA-AZ-03-545,).
- Lenters, M. (n. d.). "Roundabouts and Business." PowerPoint slide presentation, undated. Sent to authors in email dated February 20, 2013.
- Lindenmann, H. P. (2006). Capacity of small roundabouts with two-lane entries. *Transportation Research Record: Journal of the Transportation Research Board*, 1988(1), 119-126.
- Lord, D., van Schalkwyk, I., Chrysler, S., & Staplin, L. (2007). A strategy to reduce older driver injuries at intersections using more accommodating roundabout design practices. *Accident Analysis & Prevention*, 39(3), 427-432.
- Mahdalová, I., Seidler, T., & Cihlářová, D. (2010). Influence of the Roundabout Geometry on Its Safety. *Transactions of the VŠB-Technical University of Ostrava. Construction Series*, 10(1), 1-9.
- Maryland State Highway Administration. (2004). *State Highway Access Manual*. Retrieved from roads.maryland.gov/ohd/accesspermits.pdf
- Maryland State Highway Administration. (2012). *Roundabout Design Guidelines*. Retrieved from http://roads.maryland.gov/ohd2/mdsha_roundabout_guidelines.pdf
- Bagdade, J., Persaud, B. N., McIntosh, K., Yassin, J., Lyon, C. A., Redinger, C., ... & Butch, W. A. (2011). *Evaluating the Performance and Safety Effectiveness of Roundabouts* (No. RC-1566).
- Minnesota Department of Transportation (MnDOT). (2008). *MnDOT Access Management Manual*. Retrieved from www.dot.state.mn.us/accessmanagement/pdf/manualchapters/chapter2.pdf

- Minnesota Department of Transportation (MnDOT). (2009). *MnDOT Road Design Manual: Chapter 12, Design Guidelines for Modern Roundabouts*. Retrieved from <http://dotapp7.dot.state.mn.us/edms/download?docId=1062365>
- Møller, M., & Hels, T. (2008). Cyclists' perception of risk in roundabouts. *Accident Analysis & Prevention*, 40(3), 1055-1062.
- Montella, A., Turner, S., Chiaradonna, S., & Aldridge, D. (2013). Roundabout Design Practices: International Overview and Insights to Update the Italian Standard. In *Transportation Research Board 92nd Annual Meeting* (No. 13-2129).
- New Hampshire Department of Transportation (NHDOT). 2007 (Revised in 2009). *NHDOT Supplemental Design Criteria*. Retrieved from www.nh.gov/dot/org/projectdevelopment/highwaydesign/roundabouts/documents/RoundaboutFundamentals.pdf
- Park, L. & Pierce, D. (2013). Roundabouts and the Accommodation of Large Trucks: A Motor Carrier Perspective, Proceedings of the 92nd Annual Meeting of the Transportation Research Board, Washington, D.C.
- Pennsylvania Department of Transportation (PennDOT). (2007). *Guide to Roundabout* (Publication No. 414).
- Persaud, B. N., Retting, R. A., Garder, P. E., & Lord, D. (2001). Safety effect of roundabout conversions in the United States: Empirical Bayes observational before-after study. *Transportation Research Record: Journal of the Transportation Research Board*, 1751(1), 1-8.
- Polus, A., & Shmueli, S. (1997). Analysis and Evaluation of the Capacity of Roundabouts. *Transportation Research Record: Journal of the Transportation Research Board*, 1572(1), 99-104.
- Polus, A., Lazar, S. S., & Livneh, M. (2003). Critical gap as a function of waiting time in determining roundabout capacity. *Journal of Transportation Engineering*, 129(5), 504-509.
- Potts, I. B., Harwood, D. W., Torbic, D. J., Richard, K. R., Gluck, J. S., Levinson, H. S., ... & Ghebrial, R. S. (2004). NCHRP Report 524: Safety of U-Turns at Unsignalized Median Openings. *Transportation Research Board of the National Academies, Washington, DC*. Retrieved from http://www.nap.edu/catalog.php?record_id=13768
- Prytyka, G. & Sullivan, F. (2012). *Roundabouts, Florida's Implementation Strategy*. Tallahassee, Florida. Retrieved from www.dot.state.fl.us/structures/designExpo2012/Presentations/Roundabouts_Final-Expo-2012.pdf
- PTV Group. (2013) Retrieved Dec. 29, 2013 from <http://vision-traffic.ptvgroup.com/en-us/products/ptv-vissim>
- Retting, R. A., Persaud, B. N., Garder, P. E., & Lord, D. (2001). Crash and injury reduction following installation of roundabouts in the United States. *American Journal of Public Health*, 91(4), 628.
- Richfield, V., & Hourdos, J. (2013). Effect of Signs and Striping on Roundabout Safety: An Observational Before/After Study. In *Transportation Research Board 92nd Annual Meeting* (No. 13-4568).
- Robinson, B.W., Rodegerdts, L., Scarborough, W., Kittelson, W., Troutbeck, R. et al. (2000). *Roundabouts: An Informational Guide*. (FHWA-RD-00-067). Retrieved from <http://www.fhwa.dot.gov/publications/research/safety/00067/00067.pdf>
- Rodegerdts, L., Blogg, M., Wemple, E., Myers, E., Kyte, M., Dixon, M., et al. (2007). *Roundabouts in the United States* (Vol. 572). Transportation Research Board National Research. Retrieved from http://onlinepubs.trb.org/onlinepubs/nchrp/nchrp_rpt_572.pdf

- Rodegerdts, L., Bansen, J., Tiesler, C., Knudsen, J., Myers, E., Johnson, M., et al. (2010). *Roundabouts: An Informational Guide*. NCHRP Report 672. Washington, DC: National Cooperative Highway Research Program. Retrieved from http://onlinepubs.trb.org/onlinepubs/nchrp/nchrp_rpt_672.pdf
- Rodegerdts, L., Blogg, M., Wemple, E., Myers, E., Kyte, M., Dixon, M., List, G., Flannery, A., Troutbeck, R., Brilon, W., Wu, N., Persaud, B., Lyon, C., Harkey, D. & Carter, D. (2006). *NCHRP Web-only Document 94: Appendixes to NCHRP Report 572: Roundabouts in the United States*. Washington, DC: Transportation Research Board. Retrieved from http://onlinepubs.trb.org/onlinepubs/nchrp/nchrp_w94.pdf
- Rose, D. C., Gluck, J., Williams, K., & Kramer, J. (2005). *NCHRP Report 548: A guidebook for including access management in transportation planning*. Transportation Research Board, Washington, DC. Retrieved from http://onlinepubs.trb.org/onlinepubs/nchrp/nchrp_rpt_548.pdf
- Rue, H., McNally, L., Rooney, K., Santalucia, P., Raulerson, M., Lim-Yap, J., Mann, J., & Burden, D. (2010). *Livability in Transportation Guidebook: Planning Approaches that Promote Livability* (No. FHWA-HEP-10-028).
- Russell, E., Landman, E. D., & Godavarthy, R. (2012). *A Study of the Impact of Roundabouts on Traffic Flows and Business* (No. K-TRAN: KSU-09-10). Kansas Department of Transportation.
- Sacchi, E., Bassani, M., & Persaud, B. (2011). Comparison of safety performance models for urban roundabouts in Italy and other countries. *Transportation Research Record: Journal of the Transportation Research Board*, 2265(1), 253-259.
- Saccomanno, F. F., Cunto, F., Guido, G., & Vitale, A. (2008). Comparing safety at signalized intersections and roundabouts using simulated rear-end conflicts. *Transportation Research Record: Journal of the Transportation Research Board*, 2078(1), 90-95.
- Schroeder, B. J., Roupail, N. M., & Hughes, R. G. (2008). Toward Roundabout Accessibility—Exploring the Operational Impact of Pedestrian Signalization Options at Modern Roundabouts. *Journal of Transportation Engineering*, 134(6), 262-271.
- Schroeder, B. (2013). *Blind Pedestrians Access to Roundabouts and Other Complex Intersections*. North Carolina State University. Retrieved from <http://www.itre.ncsu.edu/ITRE/research/Pedestrian-Accessibility/index.html>
- Schroeder, B., Hughes, R., Roupail, N., Cunningham, C., Salamati, K., Long, R., ... & Myers, E. (2011). NCHRP Report 674 Crossing Solutions at Roundabouts and Channelized Turn Lanes for Pedestrians with Vision Disabilities. *Transportation Research Board of the National Academies, Washington, DC*. Retrieved from http://onlinepubs.trb.org/onlinepubs/nchrp/nchrp_rpt_674.pdf
- Shen, L. D., Elbadrawi, H. R., & Ospina, D. I. (2000). *Bicycle and Pedestrian Considerations at Roundabouts* (No. Final Report).
- Singer, L. and Hicks, T (2000). *An Engineer's Dilemma: Accommodating the Needs of People with Disabilities at Modern Urban Roundabouts*. Institute of Transportation Engineers.
- Sisiopiku, V. P., & Oh, H. U. (2001). Evaluation of roundabout performance using SIDRA. *Journal of Transportation Engineering*, 127(2), 143-150.
- Stamatiadis, N., House, B., Brickey, J., Hartman, D., Chen, M., Pigman, J., Boddu, K., Patangay, S. & Elwood, E. (2004). *Access management for Kentucky* (No. KTC-04-05/SPR251-01-1F).
- Stanek, D., & Milam, R. T. (2005). High-capacity roundabout intersection analysis: going around in circles. *Transportation Research E-Circular*, (E-C083).
- St-Aubin, P., Saunier, N., Miranda-Moreno, L. F., & Ismail, K. (2013). Detailed Driver Behaviour Analysis and Trajectory Interpretation at Roundabouts Using Computer Vision Data. In *Transportation Research Board 92nd Annual Meeting* (No. 13-5255).
- Stone, J. R., Chae, K., & Pillalamarri, S. (2002). *The effects of roundabouts on pedestrian safety*. Southeastern Transportation Center.

- Taekratok, T. (1998). *Modern roundabouts for Oregon* (No. OR-RD-98-17). Oregon Department of Transportation.
- Transportation Research Board (TRB). (2000). *Highway Capacity Manual*. National Research Council: Washington, D.C.
- Transportation Research Board (TRB). (2003). *Access Management Manual*. National Research Council: Washington, D.C.
- Transportation Research Board (TRB). (2010a). *Highway Capacity Manual*. National Research Council: Washington, D.C.
- Transportation Research Board (TRB). Task Force on Development of the Highway Safety Manual, American Association of State Highway Transportation Officials. Joint Task Force on the Highway Safety Manual, & National Cooperative Highway Research Program. (2010b). *Highway Safety Manual* (Vol. 1). AASHTO.
- Transportation Research Board (TRB) (2014). *NCHRP 03-100 Evaluating the Performance of Corridors with Roundabouts (Project Description)* Retrieved from <http://apps.trb.org/cmsfeed/trbnetprojectdisplay.asp?projectid=2950>
- Trueblood, M. (2013). Synchro and SimTraffic Roundabout Demo. In *ITE Technical Conference and Exhibit*.
- Trueblood, M., & Dale, J. (2003). Simulating roundabouts with VISSIM. In *2nd Urban Street Symposium: Uptown, Downtown, or Small Town: Designing Urban Streets That Work*.
- Turner, S. & Brown, M. (2013). *Pushing the Boundaries of Road Safety Risk Analysis*, IPENZ Transportation Group Conference Dunedin, New Zealand
- Uddin, W., Headrick, J., & Sullivan, J. S. (2012). Performance Evaluation of Roundabouts for Traffic Flow Improvements and Crash Reductions at a Highway Interchange in Oxford, MS. In *Transportation Research Board 91st Annual Meeting* (No. 12-3844).
- United States Access Board (USAB). (2006). *Pedestrian Access to Modern Roundabouts: Design and Operational Issues for Pedestrians who are Blind* Retrieved from <http://safety.fhwa.dot.gov/intersection/resources/fhwasa09027/resources/Pedestrian%20Access%20to%20Modern%20Roundabouts.mht>
- Valdez, M., Cheu, R. L., & Duran, C. (2011). Operations of Modern Roundabout with Unbalanced Approach Volumes. *Transportation Research Record: Journal of the Transportation Research Board*, 2265(1), 234-243.
- Virginia Department of Transportation (VDOT). (2007). *Access Management Design Standards for Entrances and Intersections*.
- Vlahos, E., Polus, A., Lacombe, D., Ranjitkar, P., Faghri, A., & Fortunato, B. R. (2008). Evaluating the Conversion of All-Way Stop-Controlled Intersections into Roundabouts. *Transportation Research Record: Journal of the Transportation Research Board*, 2078(1), 80-89.
- Waddell, E. (1997). Evolution of Roundabout Technology: A History-Based Literature Review. In *Compendium of Technical Papers, 67th Annual Meeting, Institute of Transportation Engineers, Boston (August 1997)*.
- Wang, Z., Boon, T. O., & Rakha, H. (2013). Roundabout Versus Traffic Signal Control: Comparative Analysis. In *Transportation Research Board 92nd Annual Meeting* (No. 13-4422).
- Wei, T., Grenard, J. L., & Shah, H. R. (2011). Developing Capacity Models for Local Roundabouts. *Transportation Research Record: Journal of the Transportation Research Board*, 2257(1), 1-9.
- Williams, K. (2002). *Driveway Regulation Practices* (Vol. 304). Transportation Research Board. Retrieved from http://www.cutr.usf.edu/research/access_m/pdf/nchrp_syn_304.pdf

- Williams, K. (2004). *Cooperative Agreements for Corridor Management* (Vol. 337). Transportation Research Board. Retrieved from http://www.cutr.usf.edu/research/access_m/pdf/nchrp_syn_337.pdf
- Williams, K. M., & Levinson, H. S. (2008). Access Management: Past, Present, and Future. In *8th National Conference on Access Management*.
- Williams, K. M. & Marshall, M. A. (1996). *Managing Corridor Development: A Municipal Handbook*. Retrieved from <http://www.cutr.usf.edu/pdf/corridor.pdf>
- Wisconsin Department of Transportation (WisDOT). (2011). *The Facilities Development Manual, Chapter 11, Section 26 Roundabouts*. Retrieved from www.dot.wisconsin.gov/safety/motorist/roaddesign/roundabouts/design.htm
- Wisconsin Department of Transportation (WisDOT). (2013). *WSDOT Design Manual 22.01.08: Chapter 1320 Roundabouts*. Retrieved from <http://www.wsdot.wa.gov/publications/manuals/fulltext/M22-01/1320.pdf>
- Yin, D., & Qiu, T. Z. (2011). Comparison of Macroscopic and Microscopic Simulation Models in Modern Roundabout Analysis. *Transportation Research Record: Journal of the Transportation Research Board*, 2265(1), 244-252.
- Zirkel, B., Park, S., McFadden, J., Angelastro, M., & McCarthy, L. A. (2013). Analysis of Sight Distance, Crash Rate, and Operating Speed Relationships for Single Lane Roundabouts in the United States. In *Transportation Research Board 92nd Annual Meeting* (No. 13-1847).

Appendix A: Roundabouts Features and Dimensions

Key Features of a Modern Roundabout

Source: (Rodegerdts et al., 2010, 6)

Table A.1. Key Features of a Modern Roundabout

Feature	Description
Central island	The <i>central island</i> is the raised area in the center of a roundabout around which traffic circulates.
Splitter island	A splitter island is a raised or painted area on an approach used to separate entering from existing traffic, deflect and slow entering traffic, and provide storage space for pedestrians crossing the road in two stages.
Circulatory roadway	The circulatory roadway is the curved path used by vehicles to travel counterclockwise around the central island.
Apron	An apron is a raised section of pavement around the central island adjacent to the circulatory roadway that can accommodate the wheel tracking of larger vehicles on smaller roundabouts.
Yield line	A yield line is a pavement marking that designates the point of entry from an approach into the circulatory roadway and is generally placed along the inscribed circle. Entering vehicles must yield to any circulating traffic coming from the left, before crossing this line into the circulatory roadway.
Accessible pedestrian crossing	Accessible pedestrian crossings should be provided at all roundabouts. The crossing location is set back from the yield line, and the splitter island is cut to allow pedestrians, wheelchairs, strollers, and bicycles to pass through.
Bicycle treatments	Bicycle treatments at roundabouts provide bicyclists the option of travelling through the roundabout either as a vehicle or as a pedestrian, depending on the bicyclist's level of comfort.
Landscaping buffer	Landscaping buffers are provided at most roundabouts to separate vehicular and pedestrian traffic and to encourage pedestrians to cross only at the designated crossing locations. Landscaping buffers can also significantly improve the aesthetics.

Dimensions

Source from: (Rodegerdts et al., 2010, 7)

Table A.2. Dimensions of Roundabouts

Dimension	Description
Inscribed circle diameter	The inscribed circle diameter is the basic parameter used to define the size of a roundabout. It is measured between the outer edges of the circulatory roadway.
Circulatory roadway width	The circulatory roadway width defines the roadway width for vehicle circulation around the central island. It is measured as the width between the outer edge of this roadway and the central island. It does not include the width of any mountable apron, which is defined to be part of the central island.
Approach width	The approach width is the width of the roadway used by approaching traffic upstream of any changes in width associated with the roundabout.

Dimension	Description
Departure width	The approach width is typically no more than half of the total width of the roadway.
Entry width	The departure width is the width of the roadway used by departing traffic downstream of any changes in width associated with the roundabout. The departure width is typically less than or equal to half the total width of the roadway.
Exit width	The entry width defines the width of the entry where it meets the inscribed circle. It measures perpendicularly from the right edge of the entry to the intersection point of the left edge line and the inscribed circle.
Entry radius	The exit width defines the width of the exit where it meets the inscribed circle. It is measured perpendicularly from the right edge of the exit to the intersection point of the left line and the inscribed circle.
Exit radius	The entry radius is the minimum radius of curvature of the outside curb at the entry.
	The exit radius is the minimum radius of curvature of the outside curb at the exit.

Appendix B: State Policies

This section supports the states' review of roundabout information, access management, and driveway spacing guidance with additional detail not included in Chapters Four and Five. This section is broken down by state.

Table B.3. State Websites and Guidance on Roundabouts and Access Management

State	Roundabout	Access Management
Alabama		search engine: access management
Alaska	http://www.alaskaroundabouts.com/index.html	
Arizona	http://www.azdot.gov/CCPartnerships/Roundabouts/index.asp	http://www.azaccessmanagement.com/
California	http://www.dot.ca.gov/hq/oppd/roundabt/	
Colorado	http://www.coloradodot.info/projects/i70edwardsinterchange/area-roundabout-history.html	
Connecticut	http://www.ct.gov/dot/cwp/view.asp?a=4109&q=467780&PM=1	
Delaware	http://deldot.gov/information/community_programs_and_services/roundabouts/index.shtml	
Florida	Search Engine: roundabout (contains much information about roundabouts)	http://www.dot.state.fl.us/planning/systems/sm/accman/
Georgia	http://www.dot.ga.gov/travelinggeorgia/trafficcontrol/roundabouts/Pages/default.aspx	http://www.dot.ga.gov/doingbusiness/permits/Pages/AccessManagement.aspx
Indiana		http://www.in.gov/indot/2512.htm
Iowa	http://www.iowadot.gov/roundabouts/roundabouts.htm	http://www.iowadot.gov/traffic/access/index.html
Kansas	http://www.ksdot.org/burTrafficEng/Roundabouts/roundabout.asp	http://www.ksdot.org/accessmanagement/
Kentucky	http://transportation.ky.gov/congestion-toolbox/pages/roundabouts.aspx	Search Engine: access management
Louisiana	http://www.dotd.la.gov/administration/public_info/projects/roundabouts/	Search Engine: access management (Brochure)
Maine		http://www.maine.gov/mdot/ppp/accessmgmt/index.htm
Maryland	http://www.marylandroads.com/Pages/Roundabouts.aspx	http://roads.maryland.gov/index.aspx?pageid=320&d=95
Michigan	http://michigan.gov/mdot/0,1607,7-151-9615_53039---,00.html	http://www.michigan.gov/mdot/0,1607,7-151-9621_11041_29705---,00.html
Minnesota	http://www.dot.state.mn.us/roundabouts/	http://www.dot.state.mn.us/accessmanagement/
Mississippi		Search Engine: access management
Missouri	Per Local District: Kansas City, Northeast,	http://www.modot.org/safety/AccessMan

State	Roundabout	Access Management
	Southwest	agement.htm
Montana	http://www.mdt.mt.gov/travinfo/roundabouts/about.shtml	http://www.mdt.mt.gov/research/toolkit/m1/pptools/ds/am.shtml
Nevada	http://www.nevadadot.com/Traveler_Info/Safety/Roundabouts.aspx	http://www.nevadadot.com/Content.aspx?id=6274&terms=access%20management
New Jersey		Search Engine: access management
New York	https://www.dot.ny.gov/main/roundabouts/background	
Ohio	Search Engine: roundabout	http://www.dot.state.oh.us/districts/D01/PlanningPrograms/trafficstudies/Pages/Access-Management.aspx
Oregon	http://www.oregon.gov/ODOT/hwy/engservices/Pages/roundabout_home.aspx	http://www.oregon.gov/ODOT/HWY/ACCESSMGT/Pages/index.aspx
Pennsylvania	http://www.dot.state.pa.us/Internet/web.nsf/Secondary?openframeset&frame=main&src=RoundaboutContactInfo?readform	Search Engine: access management
Rhode Island	http://www.dot.ri.gov/engineering/trafficdesign/roundabouts.asp	
South Dakota		http://www.sddot.com/transportation/highways/management/Default.aspx
Vermont		http://vtransplanning.vermont.gov/vam
Virginia	http://www.virginiadot.org/info/faq-roundabouts.asp	http://www.virginiadot.org/info/access_management_regulations_and_standards.asp
Washington	http://www.wsdot.wa.gov/Safety/roundabouts/default.htm	
Wisconsin	http://www.dot.wisconsin.gov/safety/motorist/roaddesign/roundabouts/index.htm	

Table B.4. Roundabout Guidelines in Driveway or Highway Manuals

No	Date	State	Document Title	Description
1	2000	Florida	Manual on Uniform Traffic Studies, Chapter 16 - Roundabouts	Written by FDOT and published in 2000, this 16-page report is the last chapter in the FDOT Manual on Uniform Traffic Studies (MUTS). The MUTS establishes minimum standards for conducting traffic-engineering studies on roads near the jurisdiction of the FDOT. This chapter on roundabouts justifies their use in the State of Florida, and compares them to three other alternatives to intersection control – traffic signals, two-way stop control (TWSC), and all-way stop control (AWSC). This chapter cites the 1996 FDOT <i>Florida Roundabout Guide</i> for specific guidelines on roundabout location, design, and operation.
2	2007	New Hampshire	NHDOT Supplemental Design Criteria	Written by NHDOT, the 5-page supplemental design criteria mentions the considerations for roundabout design, including operation (with attached capacity worksheet, and RODEL setting), and geometric design. Design vehicle receives additional attention in this document. FHWA <i>Roundabouts, An Informational Guide</i> (Robinson et al. 2000).
3	2009	Iowa	Design Manual Chapter 6 Geometric Design, 6A-3 Modern Roundabout	Written by Iowa DOT, Chapter 6 of the <i>Geometric Design</i> manual includes a 16-page section on modern roundabouts for Iowa. The chapter outlines how roundabouts are classified in comparison with other traffic intersections, key features and geometric elements of roundabouts, roundabout operations and design, in addition to sections on roundabout education and safety. A significant portion of the chapter addresses considerations and feasibility of roundabout implementation, taking into account regional context, access management issues, and safety factors.
3	2009	Minnesota	MnDOT Road Design Manual: Chapter 12. Design Guidelines for Modern Roundabouts	Written by Minnesota DOT, this design guideline document shows an enhancement table of typical inscribed circle diameter with daily service volume, intersection control evaluation and site requirement sections, and special designs to accommodate specific land uses. Additionally, this document suggests RODEL and ARCADY as tools to examine intersection control evaluations.
4	2011	Maryland	Maryland Design Guidelines: Chapter 3C: Roundabout Markings	Written by the Maryland State Highway Administration, this 16-page chapter includes design guidelines for pavement markings in roundabouts in Maryland. It includes markings for one-, two-, and three-lane roundabouts, as well as for crosswalk, pedestrian, and bicyclist markings through roundabouts.
5	2011	Washington	Design Manual 22.01.08: Chapter 1320 - Roundabouts	Written by Washington State DOT, the 50-page section gives information about the procedures to design a roundabout at a specific statewide level. This document explains multiple access circulation in section 1320.11 including access, parking and transit facilities. Information about access: “No road approach connections to the circulating roadway are allowed at roundabouts unless they are designed as legs to the roundabout. It is desirable that road approaches not be located on the approach or departure legs within the length of the splitter island.” (WSDOT, 2011, pp. 1320-21). For driveways, “if the parcel adjoins two legs of the roundabout, it

				is acceptable to provide a right-in/right-out driveway within the length of the splitter islands on both legs. This provides for all movements; design both driveways to accommodate their design vehicle.” (WSDOT, 2011, pp. 1320-21)
6	2010	Kentucky	Design Guidance for Roundabout Intersections	Written by the Director of the Division of Highway Design in the Kentucky DOT, this 29-page report gives specific explanations of how Kentucky may review and approve roundabout designs. The document also includes guides for warrant and operational analysis. This operational analysis includes the relation to capacity aspect in the roundabout.
7	2011	Wisconsin	Facilities Development Manual, Chapter 11, Section 26: Roundabouts	Written by the Wisconsin DOT in 2011, the 79-page section shows the complete design process of a roundabout and other supplemental aspects. The first supplement is on the guidance of shared-use paths for bicyclists. In regard to access management, this guideline considers three aspects to locate a driveway on the roundabout entry or exit: volume of driveways, operational impact, and sight distance between users.

Table B.5. Specific Manuals on Roundabout Guidance

No	Date	State	Document Title	Description
1	1996	Florida	Florida Roundabout Guide	Written by the FDOT and published in 1996, the 109-page report outlines roundabout design and guidance in Florida. This document was prepared earlier than FHWA's <i>Roundabouts, An Informational Guide</i> (Robinson et al., 2000). The main way this differs from the FHWA document is the justification of why to build a roundabout. Another supplemental aspect is the explanation about SIDRA software utilization. In addition, this document also considers other software, such as ARCADY, and RODEL. This document includes the forms to determine capacity and other required documents for roundabout justification.
2	2000	Florida	Bicycle and Pedestrian Considerations at Roundabouts	Written by FDOT and published in 2000, this report examines specific concerns about bicyclists and pedestrians at the roundabouts. The results of this study are that high bicycle crash rates than those on car and pedestrian, the multilane roundabouts provide a less safe environment for bicyclists and pedestrians than one-lane roundabouts. Recommendations include building an additional bicycle facility outside the roundabout (if space is available), crossing provisions, and proper signage.
3	2012	Florida	Roundabouts, Florida's Implementation Strategy	Written by the Design Training Expo and published in 2012, this PowerPoint presentation captures supplemental aspects from <i>FHWA's Roundabouts, An Informational Guide</i> (Robinson et al., 2000), especially in regard to pedestrians, trucks, and marking information.
4	2003	Arizona	Roundabouts: An Arizona Case Study and Design Guidelines	Written by Lee Engineering and Kittelson & Associates, the 260-page report is a case study of roundabouts in Arizona. (Lee et al., 2003).
5	2003	Kansas	Kansas Roundabout Guide: A Supplement to FHWA's	Written by the Kansas DOT, Kittelson & Associates, and Transystem Corporation in 2003, the Kansas Roundabout Guide is a 176-page report that shows supplemental aspects, such as differentiating traffic circles and roundabouts with

			Roundabouts	examples from Kansas roundabouts. It also specifies the roundabout selection guidance; adding the roundabout categories on a design characteristic table (whether urban and rural roundabouts are single or double lane), detailing in design process, giving examples of five projects in Kansas for curb and pavement design, detailing the drawing of signage on urban, suburban, multilane, and showing the luminance for intersection based on pavement classification (the Portland cement concrete surface and typical asphalt surface), and roadway classification.
6	2007	Pennsylvania	Guide to Roundabouts	Written by Pennsylvania DOT, the 236-page report supplements the pedestrian aspect of <i>FHWA's Roundabouts, An Informational Guide</i> (Robinson et al., 2000), by showing detailed requirements for detectable warning surfaces and other pedestrian features.
7	2008	Iowa	Planning-Level Guidance for Modern Roundabouts	Written by Hallmark et al., this 32-page report provides the Iowa DOT with information and direction on roundabout policies, design guidelines, and public education. The project develops a roundabout task force, documents best practices of states with successful roundabout programs, develops implementation guidelines, develops draft roundabout policies, and assists in public education about roundabouts.
8	2011	Michigan	Evaluating the Performance and Safety Effectiveness of Roundabouts	Written by the Michigan DOT, this report studies safety performance on roundabouts. Using the simple before-after and Empirical Bayes analysis with a sample size of 58 roundabouts in Michigan, this research finds that “Single lane has 60.55 crashes per year reduction; Double lane; 18.56 crashes per year reduction; Triple lane; 94.76 crashes per year increase; and Fatal & A-Level; 5.39 crashes per year reduction” (MDOT, 2011, pp. 81 or 7-1). This research also suggests additional aspects of roundabouts to be considered in the next <i>Michigan State Roundabout Guide</i> . One suggestion about roundabouts that has correlation to access management would be to “consider restricting left turns into and out of driveways near roundabouts. This would reduce the number of conflict points and allow vehicles to utilize the roundabout to make an indirect left turn.” (Bagdade et al., 2011, pp. 86).
9	2012	Maryland	Roundabout Design Guidelines	Written by the Maryland State Highway Administration, this 32-page report includes guidelines for roundabout design and operations.
10	2007	California	Roundabout Geometric Design Guidance	Written by the Caltrans Division of Research and Innovation, this 113-page document includes three main topics: operation, roundabout for different users, and geometric design.

Table B.6. State Guidance on Access Management Manuals

No.	States	Name of Documents	Year	Retrieved From	Pages
1	Alabama	Access Management Manual	January, 2013	http://www.dot.state.al.us/maweb/doc/ALDOT%20Access%20Management%20Manual.pdf	65
2	Arizona	Roadway Design Guidelines	May, 2012	http://www.azdot.gov/highways/Roadway_Engineering/Roadway_Design/Guidelines/Manuals/PDF/RoadwayDesignGuidelines.pdf	412
3	California	Highway Design Manual	May 7, 2012	http://www.dot.ca.gov/hq/oppd/hdm/hdmtoc.htm	(web)
4	Colorado	State Highway Access Code	1998 (revised March 2002)	http://www.coloradodot.info/business/permits/accesspermits/references/601_1_accesscode_march2002_.pdf/view	70
5	Connecticut	Highway Design Manual	2003 (revised February, 2013)	http://www.ct.gov/dot/lib/dot/documents/dpublications/highway/cover.zip	630
6	Delaware	Standards and Regulations for Subdivision Streets and State Highway Access	2011	http://regulations.delaware.gov/register/june2011/proposed/14%20DE%20Reg%201323%2006-01-11.pdf	136
7	District of Columbia (Washington, DC)	The Policy and process for Access to the District of Columbia Interstate and Freeway System	2010	http://ddot.dc.gov/DC/DDOT/Projects+and+Planning/Standards+and+Guidelines/Interstate+and+Freeway+Access+Process/Policy+and+Process+for+Access+to+the+DC+Interstate+and+Freeway+System	(web)
8	Florida	State Highway System Access Management	2009	https://www.flrules.org/gateway/ChapterHome.asp?Chapter=14-97	(web)
9	Georgia	Regulation for Driveway and Encroachment Control	2009	http://www.dot.ga.gov/doingbusiness/PoliciesManuals/roads/Encroachment/DrivewayFull.pdf	101
10	Idaho	Access Management: Standards and Procedures for Highway Right-of-Way Encroachments	April, 2001	http://itd.idaho.gov/highways/ops/Traffic/PUBLIC%20FOLDER/Access/Idaho%20AM%20Standards%20and%20Procedures.pdf	93
11	Illinois	Chapter 35- Access Control/Access Management	September 2010	http://dot.state.il.us/desenv/BDE%20Manual/BDE/pdf/Chapter%2035%20Access%20Control-Access%20Management.pdf	52
12	Indiana	Access Management Guide	2009	http://www.in.gov/indot/files/guide_total.pdf	178
13	Iowa	Iowa Primary Highway Access Management Policy	2012	http://www.iowadot.gov/traffic/pdfs/AccessPolicy.pdf	47

No.	States	Name of Documents	Year	Retrieved From	Pages
14	Kansas	Access Management Policy	January, 2013	http://www.ksdot.org/accessmanagement/Access_Management_Policy_Jan_2013.pdf	300
15	Louisiana	Access Connection Policy	November, 2012	http://www.dotd.la.gov/highways/maintenance/maintmgt/documents/AC_Policy_Manual.pdf	81
16	Maine	Access Management Rules	March 18, 2005	http://www.maine.gov/mdot/ppp/accessmgmt/amrules.htm	(web)
17	Maryland	State Highway Access Manual	2004	http://roads.maryland.gov/ohd/accesspermits.pdf	232
18	Massachusetts	Highway Design Chapter 15 Access Management	2006	http://www.massdot.state.ma.us/Portals/8/docs/designGuide/CH_15_a.pdf	25
19	Michigan	Access Management Guidebook	October 1, 2001	http://www.accessmanagement.info/pdf/GuidebookMI.pdf	164
20	Minnesota	Access Management Manual	2008	http://www.dot.state.mn.us/accessmanagement/resources.html	(web)
21	Mississippi	Access Management Manual	2012	http://sp.mdod.ms.gov/RoadwayDesign/Documents/MISSISSIPPI%20Access%20Management%20Guide_v2_Feb2012.pdf	36
22	Missouri	Access Management Guidelines	2003	http://www.modot.org/newsandinfo/documents/AccessMgmtGuidelines_1003.pdf	51
23	Montana	Chapter 8 - Access Management	March, 2007	http://www.mdt.mt.gov/other/rw/external/manual/chapter_8.pdf	21
24	Nebraska	Access Control Policy to the State Highway System	March 1, 2006	http://www.transportation.nebraska.gov/roway/pdfs/accesscontrol.pdf	24
25	Nevada	Access Management System and Standards	1999	http://www.nevadadot.com/uploadedFiles/TrafEng_AccesMgtSysStandards.pdf	38
26	New Hampshire	Driveway Permit	March 10, 2000	http://www.nh.gov/dot/org/operations/highwaymaintenance/documents/DrivewayPolicy.pdf	43
27	New Jersey	State Highway Access Management Code	2013	http://www.state.nj.us/transportation/business/accessmgmt/NJHAMC/	89
28	New Mexico	State Highway Access Management Requirements	October 15, 2001	http://dot.state.nm.us/content/dam/nmdot/Infrastructure/Access_management_Manual.pdf	197
29	New York	Highway Design Manual Chapter 6 - Interchanges;	July 16, 2002	https://www.dot.ny.gov/divisions/engineering/design/dqab/hdm/hdm-repository/chapt_06_new_07162002.pdf	18

No.	States	Name of Documents	Year	Retrieved From	Pages
30	North Carolina	Policy on Street and Driveway Access to North Carolina Highways	July, 2003	https://connect.ncdot.gov/resources/safety/Congestion%20Mngmt%20and%20Signing/Congestion%20Management/Policy%20on%20Street%20and%20Driveway%20Access%20to%20North%20Carolina%20Highways%20Current%20Edition%20July%202003.pdf	90
31	North Dakota	Design Manual- Driveways and Access Management	July 8, 2009	http://www.dot.nd.gov/manuals/design/designmanual/DM-TOC-Master_tag.pdf	3
32	Ohio	State Highway Access Management Manual	2001	http://www.dot.state.oh.us/Divisions/Engineering/Roadway/AccessManagement/Documents/State%20Highway%20Access%20Management%20Manual%20March%202008.pdf	66
33	Oregon	Highway Approach Permitting, Access Control, and Access Management Standards	June 29, 2012	http://www.oregon.gov/ODOT/HWY/ACCESSMGT/docs/pdf/734-051_Perm_Rule.pdf	91
34	South Carolina	ARMS—Access and Roadside Management Standards	2008 (latest revision on Sept 26, 2012)	http://www.scdot.org/doing/technicalpdfs/publicationsmanuals/trafficengineering/arms_2008.pdf	130
35	South Dakota	Chapter 17—Access Management		http://sddot.com/business/design/docs/rd/rdmch17.pdf	22
36	Texas	Access Management Manual	July, 2011	http://onlinemanuals.txdot.gov/txdotmanuals/acm/acm.pdf	46
37	Utah	Accommodation of Utilities and the Control and Protection of State Highway Right of Way	January, 2006	http://www.udot.utah.gov/main/ucowner.gf?n=6599114996078154	100
38	Vermont	Access Management Program Guidelines	July 1, 1999 (Last Revision: July 22, 2005)	http://vtransengineering.vermont.gov/sites/aot_program_development/files/documents/rightofway/UandPAccManProgGuidelinesRev072205.pdf	33
39	Virginia	Access Management Design Standards for Principal Arterial/ Minor Arterials, Collectors, and local streets/ Entrances and Intersection	2012/2012 /2007	http://www.virginiadot.org/info/access_management_regulations_and_standards.asp	18/ 19/ 116
40	Washington	Access Control	June, 2009	http://www.wsdot.wa.gov/publications/manuals/fulltext/m22-01/520.pdf	8
41	West Virginia	Manual on Rules and Regulations for Constructing Driveways on State Highway Rights of way	May, 2004	http://www.transportation.wv.gov/highways/traffic/Documents/DrivewayManual.pdf	94

No.	States	Name of Documents	Year	Retrieved From	Pages
42	Wisconsin	Access Control—Facilities Development Manual	June 19, 2013	http://roadwaystandards.dot.wi.gov/standards/fdm/07-00toc.pdf	(web)
43	Wyoming	Rules and Regulations and policy for Accesses to Wyoming State Highways	March, 2005	http://www.dot.state.wy.us/files/live/sites/wydot/files/shared/Traffic/WYDOT%20Access%20Manual.pdf	48

Table B.7. Other Documents Related to Access Management

No.	States	Name of Documents	Year	Retrieved From	Pages
1	Idaho	Access Management Toolkit	August 18, 2008	http://www.compassidaho.org/documents/planning/studies/AcMgtTlkt_08Cover_Electronic.pdf	94
2	Oregon	Access Management Manual (web-based)	Various (1996 to 2004)	http://www.oregon.gov/ODOT/HWY/ACCESSMGT/Pages/accessmanagementmanual.aspx	(web)
3	Michigan	Michigan Access Management Program Evaluation	May, 2010	http://www.michigan.gov/documents/mdot/Final_MDOT_Access_Management_Evaluation_Report_by_TTI_May_2010_324062_7.pdf	112
4	New York	Project Development Manual Appendix 8: Interstate and Other Freeway Access Control and Modification	January 7, 2002	https://www.dot.ny.gov/divisions/engineering/design/dqab/dqab-repository/pdmap8.pdf	19
5	Kentucky	Access Management for Kentucky (Stamatiadis et al., 2004)	February, 2004	http://transportation.ky.gov/Congestion-Toolbox/Documents/KTC%20Access%20Management%20Report.pdf	170
6		Access Management Implementation in Kentucky Technical Support Document and Status Report	May, 2008	http://transportation.ky.gov/Congestion-Toolbox/Documents/Access%20Management%20Implementation%20Report%202008.pdf	111
7	Utah	Assessing the Safety Benefits of Access Management Techniques	May, 2006	http://www.udot.utah.gov/main/ucowner.gf?n=7861430698992951	150
8	South Carolina	South Carolina Strategic Corridor System Plan		http://www.scdot.org/inside/pdfs/planning/strategiccorridorplan.pdf	126
9	South Dakota	Review of SDDPT's Highway Access Control Process	February, 2000	http://sddot.com/business/research/projects/docs/SD1999_01_Final_Report.pdf	214
10	Washington	Right of Way Manual	March, 2013	http://www.wsdot.wa.gov/publications/manuals/fulltext/M26-01/M26-01.10Revision.pdf	62

Date	State	Document Title	Description
2006	Florida	Median Handbook	The FDOT Median Handbook is an 81-page report that borrowed "heavily" from the <i>Access Management Manual</i> , published by the Transportation Research Board; as well as <i>Transportation and Land Development</i> (Vergil Stover) published by ITE. While the handbook addresses several design considerations related to roundabouts, it does not explicitly detail anything about roundabout design or access management.
2008	Florida	Driveway Information Guide	The FDOT Driveway Information Guide is a 94-page report that addresses several design guidelines for driveway design in Florida, such as sight distance at driveways, driveway location, and pedestrian factors, but does not make any reference to roundabouts at all.

Appendix C: Access Management Techniques in State Guidelines

Table C.8. Spacing Requirements

Agency	Minimum Spacing Requirement or Guideline: Stated Distance
Alberta Transportation	200 m (660 ft)
Arizona Transportation Research Center	90 m (300 ft)
Arkansas State Highway and Transportation Department	45 m (150 ft)
California DOT	125 m (415 ft)
Colorado DOT	105 m (350 ft)
Connecticut DOT	None
E-470 Authority (Colorado)	180 m (600 ft)
Florida DOT	135 m (440 ft)
Georgia DOT	30 m (100 ft)
Illinois DOT	45 m (150 ft)
Indiana DOT	30 m (100 ft)
Iowa DOT	30 m (100 ft)
Kansas DOT	None
Louisiana DOT and Development	30 m (100 ft)
Maine DOT	150 m (500 ft)
Maryland State Highway Administration	30 m (100 ft)
Michigan DOT	30 m (100 ft)
Ministère des Transports du Québec	None
Minnesota DOT	Developing guidelines
Mississippi DOT	30 m (100 ft)
Nebraska Department of Roads	200 m (660 ft)
Nevada DOT	90 m (300 ft)
New Brunswick DOT	65 m (215 ft)
New Jersey DOT	Varies
New York DOT	30 m (100 ft)
Nova Scotia DOT and Public Works	60 m (200 ft)
Ohio DOT	180 m (600 ft)
Oregon DOT	230 m (750 ft)
South Carolina DOT	30 m (100 ft)
South Dakota DOT	200 m (660 ft)
Texas DOT	140 m (460 ft)
Utah DOT	50 m (165 ft)
Virginia Transportation Research Council	30 m (100 ft)
Washington State DOT	40 m (130 ft)
West Virginia DOT	30 m (100 ft)
Wyoming DOT	45 m (150 ft)

(Source: Gluck and Lorenz, 2010, pp. 47)

Table C.9. Access Management Elements on the States (Gluck and Lorenz, 2010, page 48)

State	General Departmental Policies	Access Code	Standards	Guidelines	Driveway Permit Manual	Roadway Design Manual	No Changes
AK	X		X				
AR	X				X		
AZ	X		X	X	X	X	
CA				X	X	X	
CO							
CT							X
DE							X
FL							
GA			X	X	X		
HI	X		X	X			
IA	X	X	X	X			
ID		X		X			
IN	X	X		X			
KS	X	X	X	X	X	X	
KY				X	X		
LA	X	X	X	X			
MD							
ME							X
MN				X			
MO							X
MS	X	X	X	X	X		
MT	X		X	X	X	X	
NC	X	X	X		X		
ND	X		X				
NE							X
NH							
NJ		X		X			
NM							X
NV							
NY		X		X			
OH					X	X	
OK					X	X	
OR							
RI							X
SC	X			X	X		
SD							
TN							
TX							X
UT	X			X			
VA			X		X	X	
VT							X
WA	X		X	X			
WI	X	X	X	X	X		
WV				X			
WY							

Table C.10. Access Management Techniques applied by the State DOTs (Gluck and Lorenz, 2010, pages 49-50)

State	Installation of medians	Spacing for median openings/breaks	Spacing for unsignalized public street intersections	Spacing for unsignalized private driveways	Spacing for traffic signals	Prohibition of certain turning movements	Corner clearance (distance from a public street intersection to the first driveway)	Spacing for cross-streets in the vicinity of interchanges
AL	X	X		X	X	X	X	X
AK	X	X	X	X	X	X	X	X
AR	X	X	X	X	X	X	X	X
AZ	X	X	X	X	X	X	X	X
CA	X	X	X	X	X	X	X	X
CO	X	X	X	X	X	X	X	X
CT	X	X	X	X	X	X	X	X
DE	X	X	X	X	X	X	X	
FL	X	X	X	X	X	X	X	X
GA	X	X	X	X	X	X	X	X
HI	X	X	X	X	X	X	X	X
IA	X	X	X	X	X	X	X	X
ID	X	X	X	X	X		X	X
IL						X		
IN	X	X		X		X	X	X
KS	X	X	X	X	X	X	X	X
KY	X	X	X	X	X	X	X	X
LA	X	X			X			X
MA	X	X	X	X	X	X	X	X
MD	X	X	X	X	X	X	X	X
ME		X			X	X	X	X
MI		X		X			X	
MN	X	X	X	X	X	X	X	
MO	X	X	X	X	X	X	X	X
MS	X	X	X	X	X	X	X	X
MT	X	X	X	X	X	X	X	X
NC	X	X				X		X
ND								
NE	X	X	X	X	X	X	X	X
NH	X	X	X	X		X	X	X
NJ		X	X	X	X	X	X	X
NM	X	X	X	X	X	X	X	X
NV	X	X	X	X	X	X	X	X
NY	X	X			X	X		
OH	X	X	X	X	X	X		X
OK	X	X	X	X	X	X	X	X
OR	X		X	X	X	X	X	X
PA	X	X	X	X	X	X	X	X
RI	X	X		X	X		X	X
SC	X	X	X	X	X		X	X
SD	X	X	X	X	X	X	X	
TN	X	X	X	X			X	X
TX	X	X		X		X	X	X
UT	X	X	X	X	X	X	X	X
VA	X	X	X	X	X	X	X	X
VT	X		X	X	X	X	X	X
WA	X	X	X	X	X	X	X	X
WI	X	X	X	X	X	X	X	X
WV	X	X	X	X	X	X	X	X
WY			X	X	X		X	X

State	Intersection sight distance and setbacks	Geometric design standards for driveways	Provisions for right-turn and left-turn lanes	Purchase of access rights	Internal connection of parking lots between adjacent parcels	Subdivision restrictions for large parcels	Requirements for Traffic Impact Studies	Requirements for Traffic Impact Fees
AL	X	X	X	X			X	
AK	X	X	X	X	X	X	X	X
AR	X	X	X	X			X	
AZ	X	X	X	X		X	X	
CA	X	X	X	X	X	X	X	X
CO	X	X	X	X	X	X	X	
CT	X	X	X	X	X	X	X	
DE	X	X	X	X	X		X	
FL	X	X	X	X	X		X	
GA	X	X	X	X	X	X	X	X
HI	X	X	X		X		X	
IA	X	X	X	X			X	
ID	X	X	X	X			X	
IL	X	X	X	X			X	
IN	X	X	X	X			X	
KS	X	X	X	X	X		X	
KY	X	X	X	X			X	
LA					X		X	
MA	X	X	X		X		X	
MD	X	X	X	X	X	X	X	
ME	X	X	X					
MI	X	X	X		X			
MN	X	X	X				X	
MO	X	X	X	X	X		X	
MS			X				X	
MT	X	X	X	X	X	X	X	
NC	X	X	X				X	
ND								
NE	X	X	X	X		X	X	
NH	X	X	X				X	X
NJ	X	X	X	X		X	X	
NM	X	X	X	X			X	
NV	X	X	X	X	X		X	X
NY	X	X	X	X			X	
OH		X	X	X	X		X	
OK	X	X	X	X	X	X	X	
OR	X	X	X	X		X	X	
PA	X	X	X	X	X		X	
RI	X	X	X	X	X		X	
SC	X	X	X				X	
SD	X		X	X			X	
TN	X	X	X					
TX				X			X	
UT	X	X	X	X	X		X	X
VA	X	X	X	X	X		X	
VT	X	X	X		X	X		
WA	X	X	X	X			X	X
WI	X	X	X	X	X	X	X	X
WV	X	X	X	X		X	X	
WY	X	X	X				X	

Appendix D: Site Selection

The figure below shows the data collection of the Clearwater roundabout, which has been debated for years. Four cameras were placed on four out of the six legs of this roundabout to record traffic interaction between driveways and approaching lanes. This roundabout is located close to a tourist attraction area; therefore traffic was significant at the time of data collection.

Pinellas	Causeway Blvd and Mandalay Ave	3/22: 3pm-5:30pm
Problems: Huge traffic, lots of spill backs into circulating lanes.		

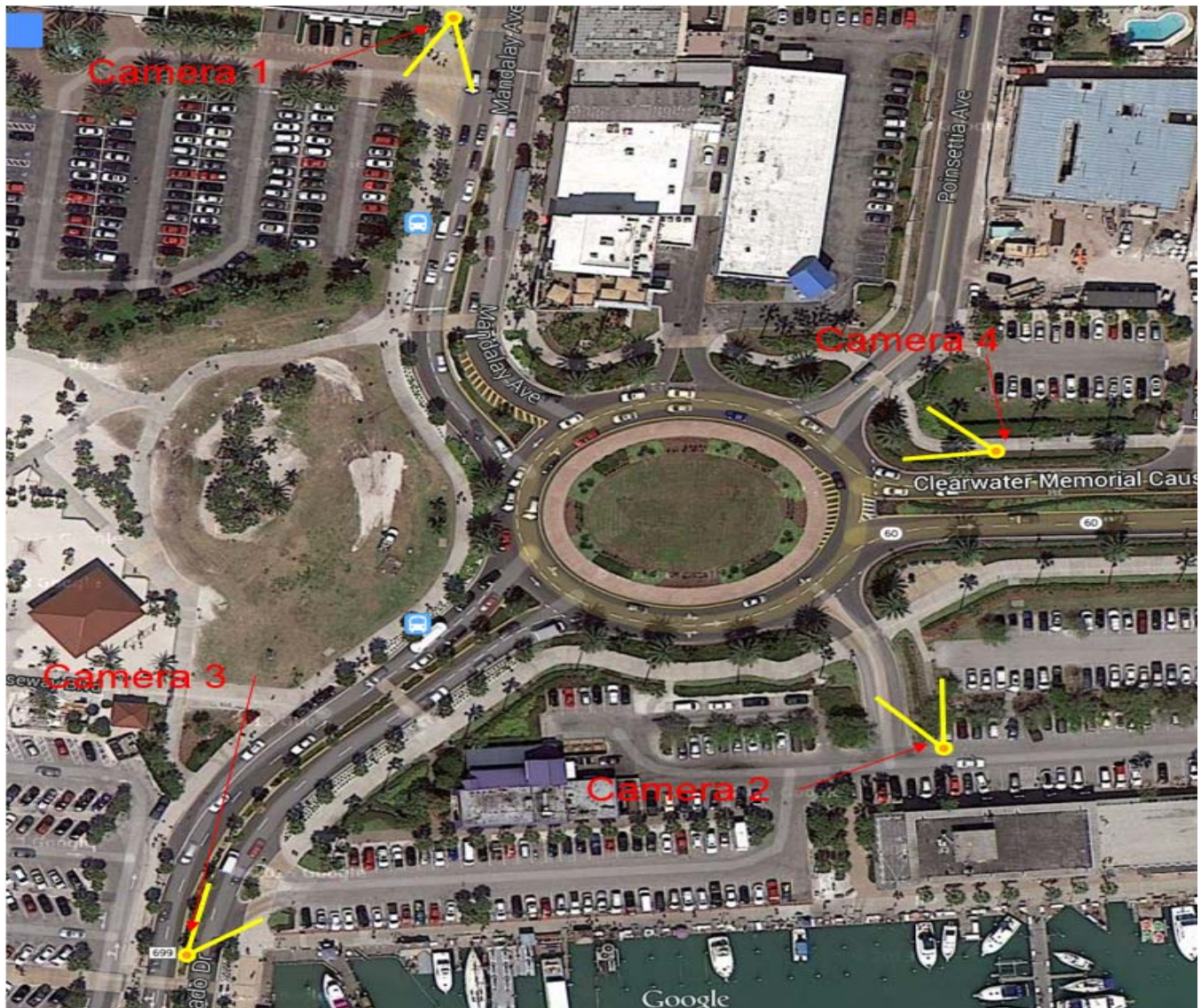

Figure D.1. Camera Location of Roundabout at Causeway Blvd and Mandalay Ave

The figure below shows a roundabout in Gainesville, Florida. This site is an ideal intersection for researchers to observe conflict between traffic on approaching/exit lanes and driveways since the distance between driveways and the roundabout is very close.

Alachua	SW 2 nd Ave and SW 6 th St.	4/5: 3pm-5:30pm
Problems: Driveway is too close to the roundabout		



Figure D.2. Camera Location of Roundabout at SW 2nd Ave and SW 6th St.

The figure below shows a roundabout site in Osceola County. Although there is a driveway close to the roundabout, we didn't observe significant conflict at the site.

Osceola	MLK Blvd. and N. Central Ave.	4/5: 11am-12pm
Problems: NA		



Figure D.3. Camera Location of Roundabout at MLK Blvd. and N. Central Ave.

The following figure shows a roundabout in Orange County, Florida. This site is close to a shopping mall so we picked a weekend to conduct data collection.

Orange	Eagle's Reserve Blvd and Dyer Blvd	4/14: 12pm-1pm
Problems: Design is abnormal		



Figure D.4. Camera Location of Roundabout at Eagle's Reserve Blvd and Dyer Blvd

The following figure shows a roundabout site in Jacksonville, Florida. It is located in the CBD area and a business center was situated right next to the roundabout. Traffic attracted and generated by the business center caused significant impact on roundabout operation.

Duval	Independent Dr. and S. Laura St.	4/23: 11am-2pm
Problems: Huge pedestrian flow, business center right next to roundabout.		



Figure D.5. Camera Location of Roundabout at Independent Dr. and S. Laura St.

The figure below shows a roundabout in St. Lucie, Florida. Although several driveways are located near the roundabout, we didn't observed many conflicts at this site.

St. Lucie	CR-707 and Ave A	5/9: 1pm-3pm
Problems: Driveway too close to roundabout		

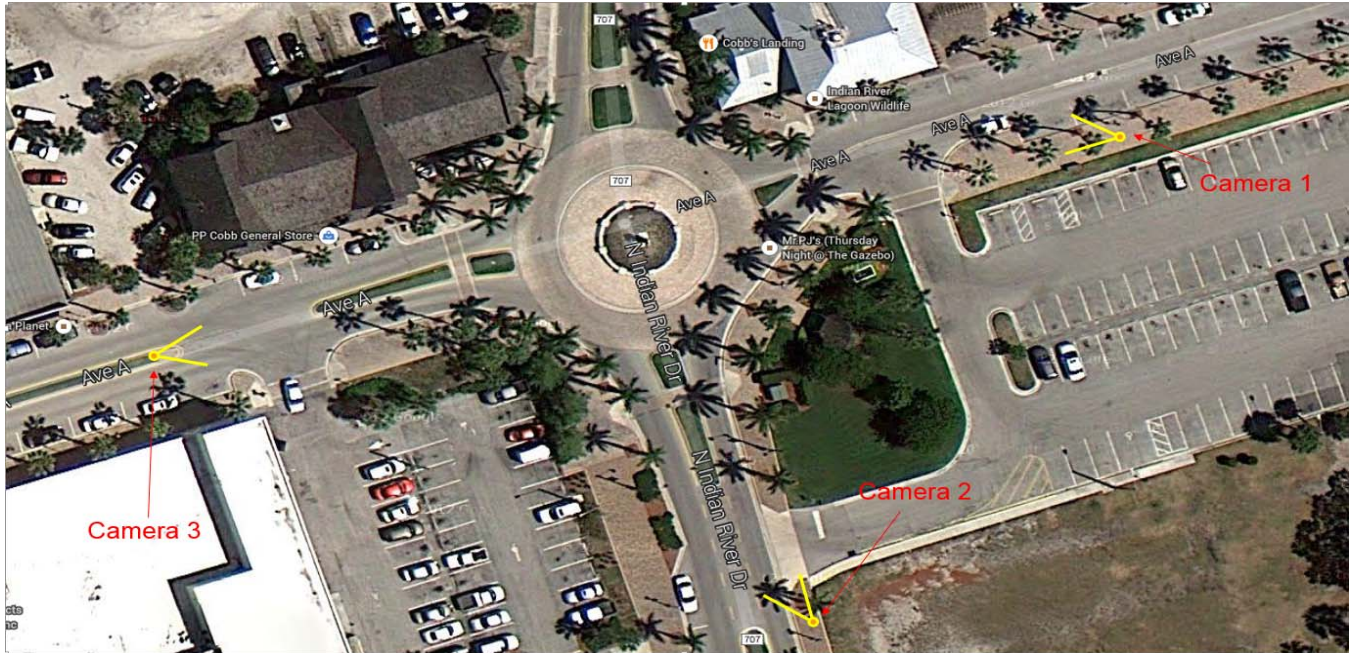

Figure D.6. Camera Location of Roundabout at CR-707 and Ave A

The figure below shows a roundabout in St. Johns, Florida. A shopping center was located near the roundabout.

St. Johns	CR-210 and Mickler Rd.	5/9: 1pm-3pm
Problems: NA		



Figure D.7. Camera Location of Roundabout at CR-210 and Mickler Rd.

The next site is a roundabout in Homestead, Florida. As we can see from the figure below, there is an AWSC intersection north of the roundabout.

Miami-Dade	NE 10th Ct. & SW 152 nd Ave.	5/13: 5pm-7:20pm
Problems: You cannot see queue in the driveway from camera 2 due to the high hedges along the roadway.		

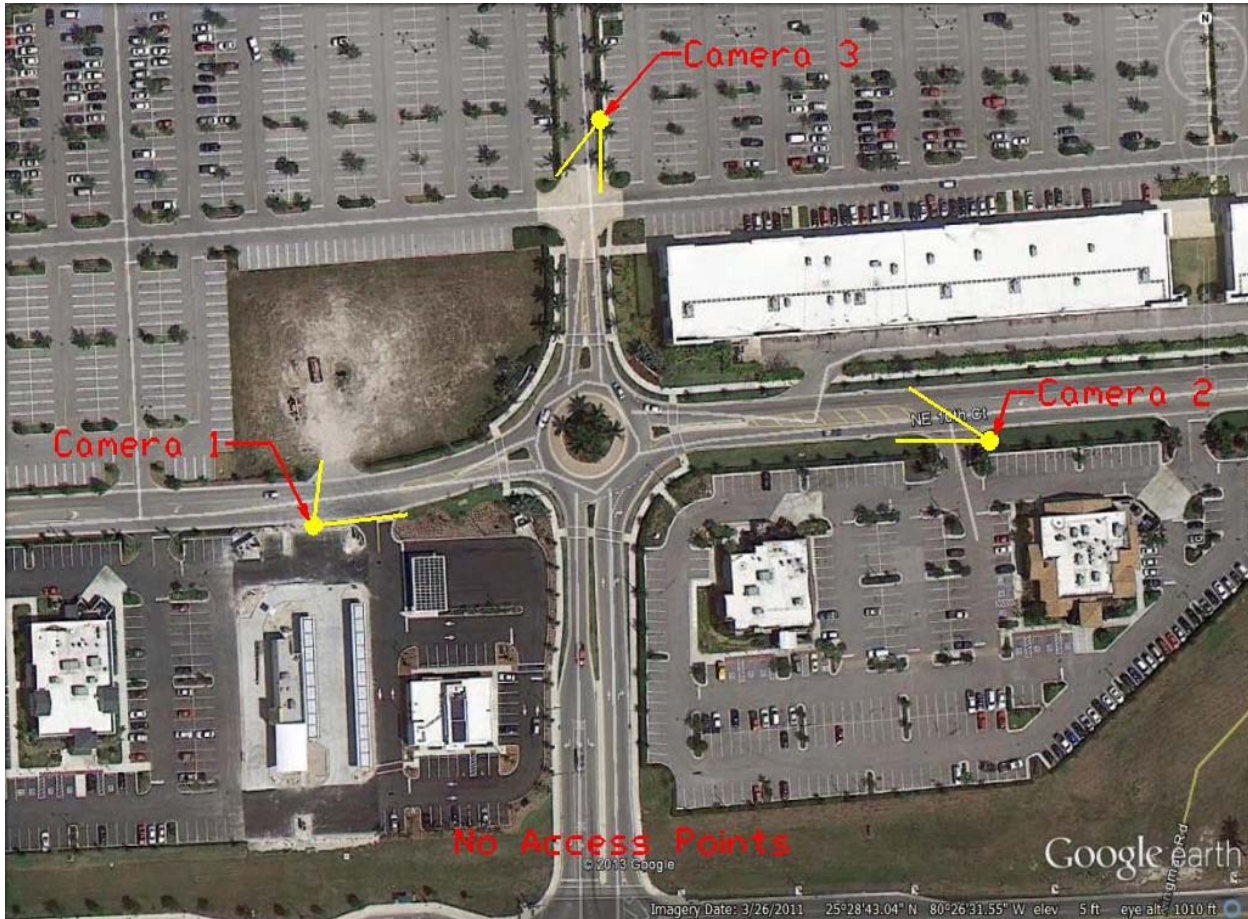

Figure D.8. Camera Location of Roundabout at NE 10th Ct. and SW 152nd Ave.

The next two roundabouts form a series of roundabouts in Miami, Florida. One of the features of these two roundabouts is on street parking is evident in these sites.

Miami-Dade	Greenway Dr. and Sagovia St.	5/14: 4:50pm-7:10pm
Problems: Long queue build-up on Coral Way westbound on easternmost leg.		

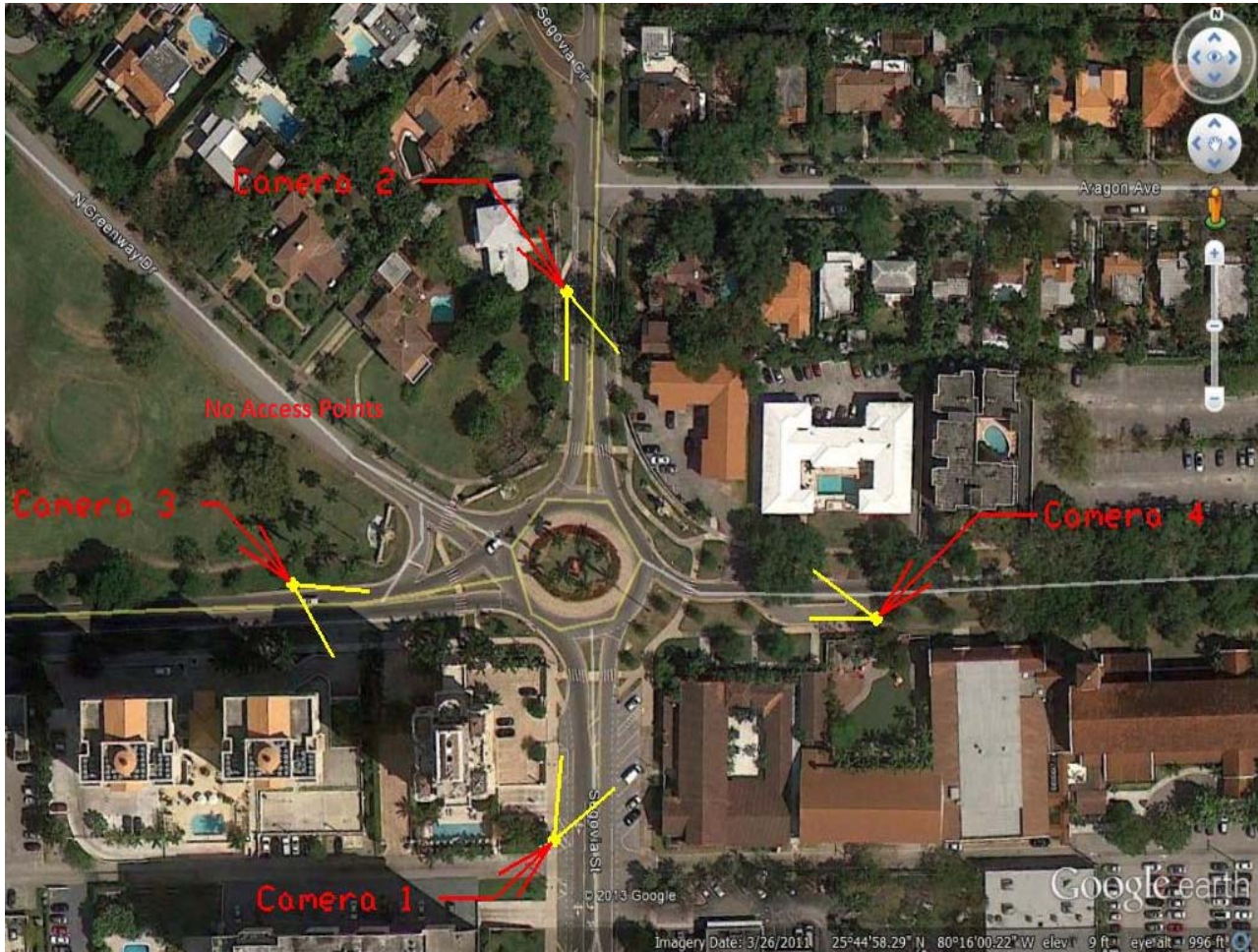

Figure D.9. Camera Location of Roundabout at Greenway Dr. and Sagovia St. & Coral Way

Miami-Dade	Biltmore Way and Sagovia St.	5/15: 4:50pm-7:15pm
Problems: Easternmost leg had heavy traffic traveling east with some spill back into the roundabout.		

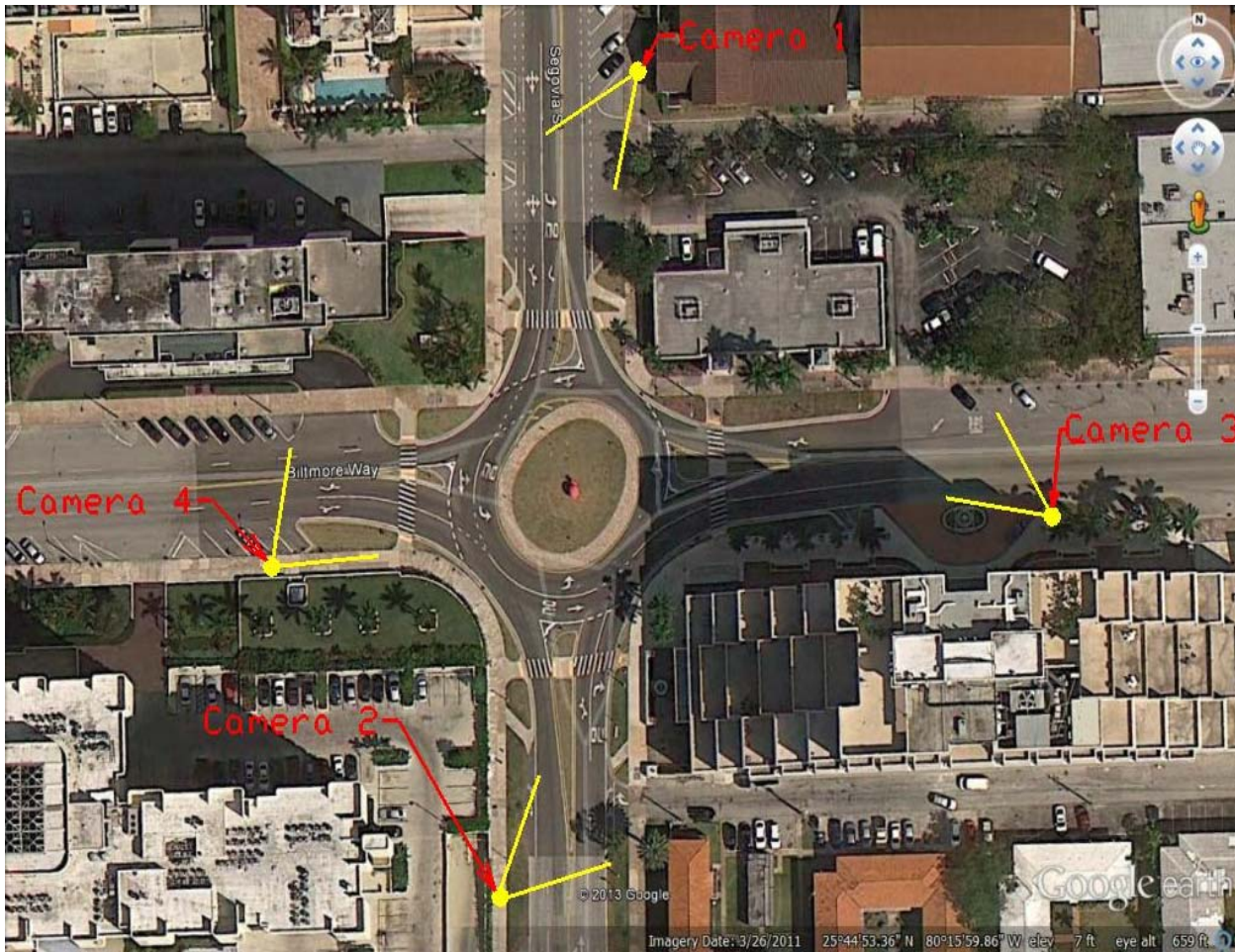

Figure D.10. Camera Location of Roundabout at Biltmore Way and Sagovia St.

The map below shows a roundabout in Broward County, Florida. This area is mostly residential with some facton of mixed-used parcel.

Broward	Holmberg Rd. & Parkside Dr.	5/16: 3:25pm-5:30pm
Problems: NA		

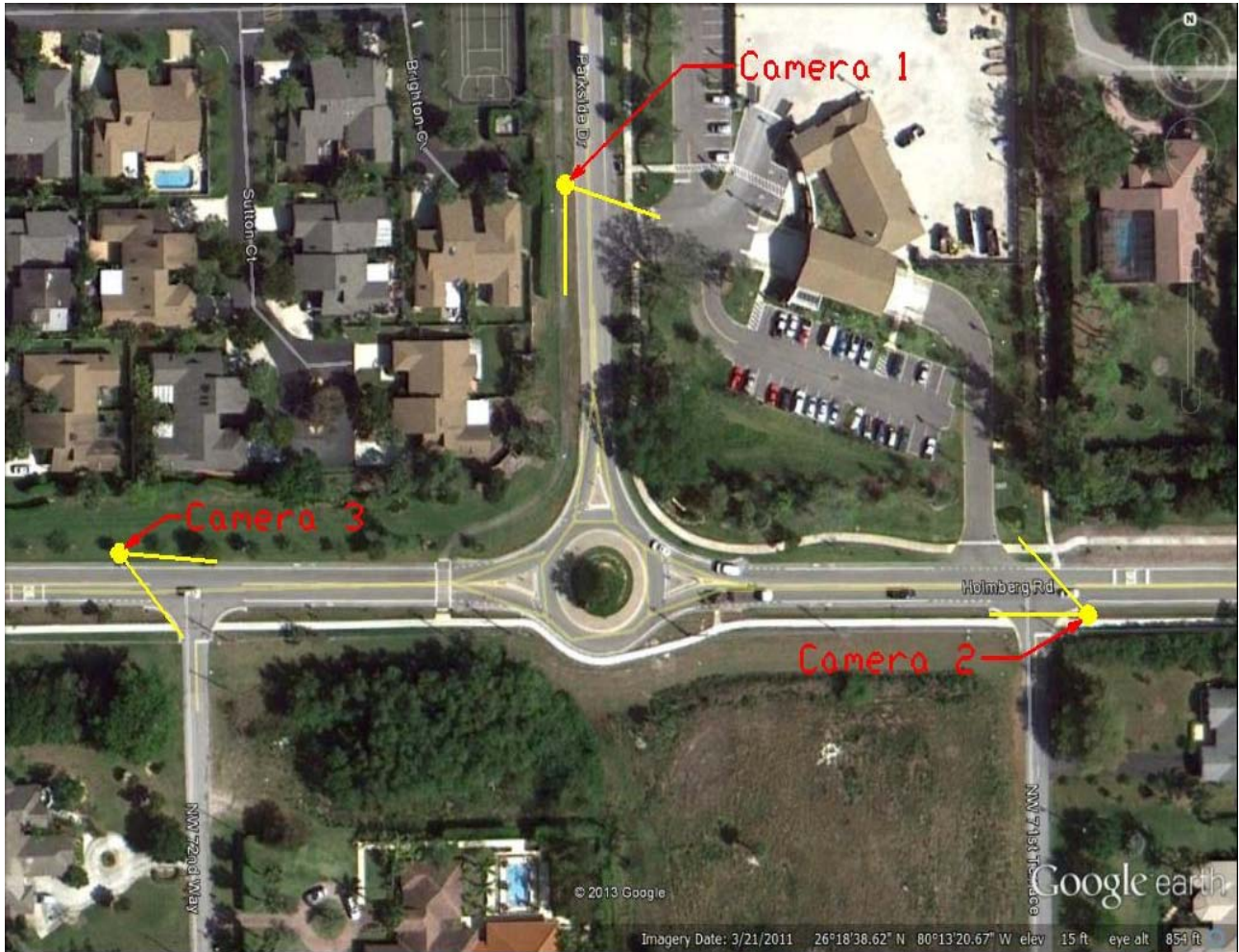

Figure D.11. Camera Location of Roundabout at Holmberg Rd. and Parkside Dr.

The map below shows a roundabout site in Miami, Florida. This site is interesting because the design is abnormal compared to other roundabouts in our list, and yet the access issue still predominates at this site.

Miami-Dade	Ponce De Leon Blvd and Ruiz Ave	5/21: 4:50pm-7:05pm
------------	---------------------------------	---------------------

Problems: For camera 3 we could not place the camera in the median due to the median being covered with bushes and trees. We had to place it across the street. There is some difficulty seeing the access point because of the cars crossing through our line of site.

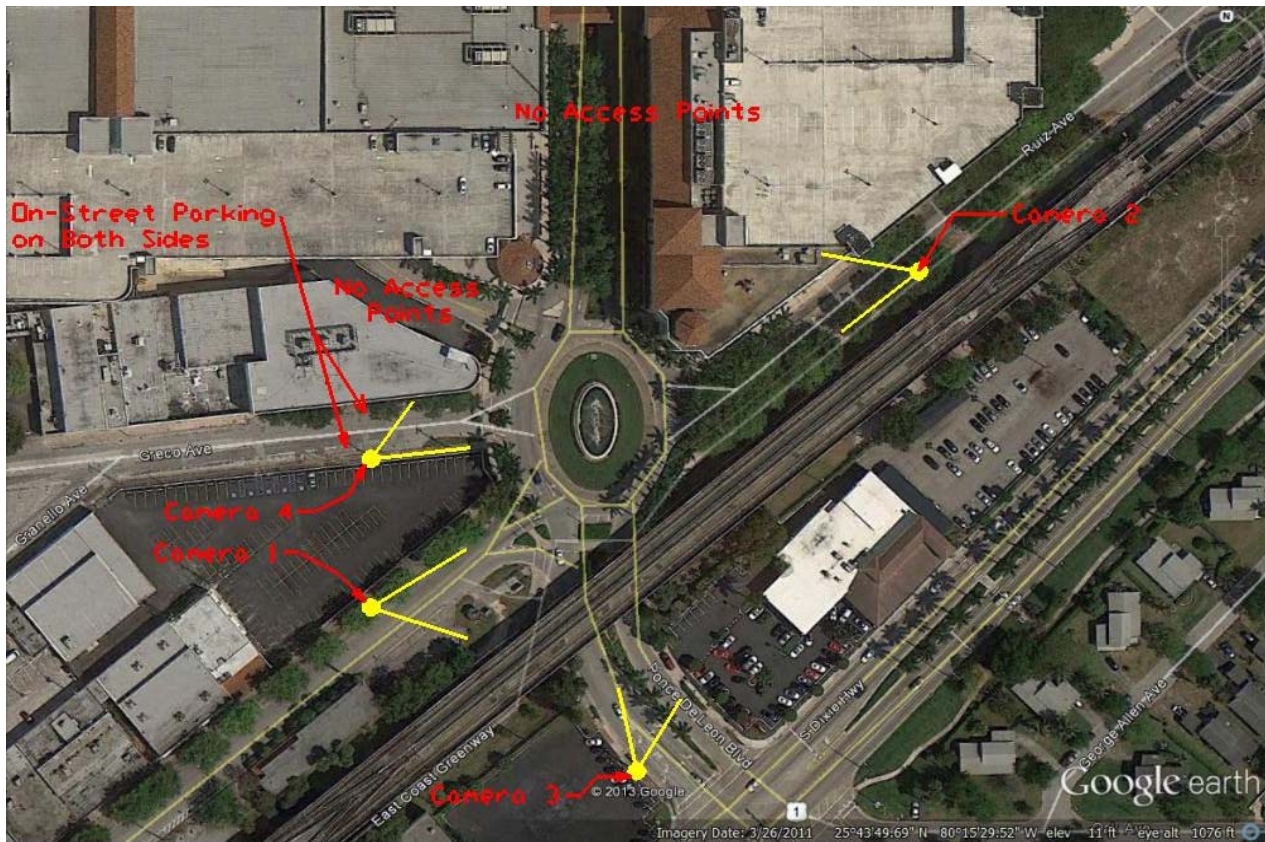

Figure D.12. Camera Location of Roundabout at Ponce De Leon Blvd. and Ruiz Ave.

The map below shows a roundabout in Broward County, Florida. This site was on the top of our list since a lot of access points were found at each lane.

Broward	Margate Blvd and NW 58 th Ave	5/23: 7:40am-9:40am
Problems: NA		

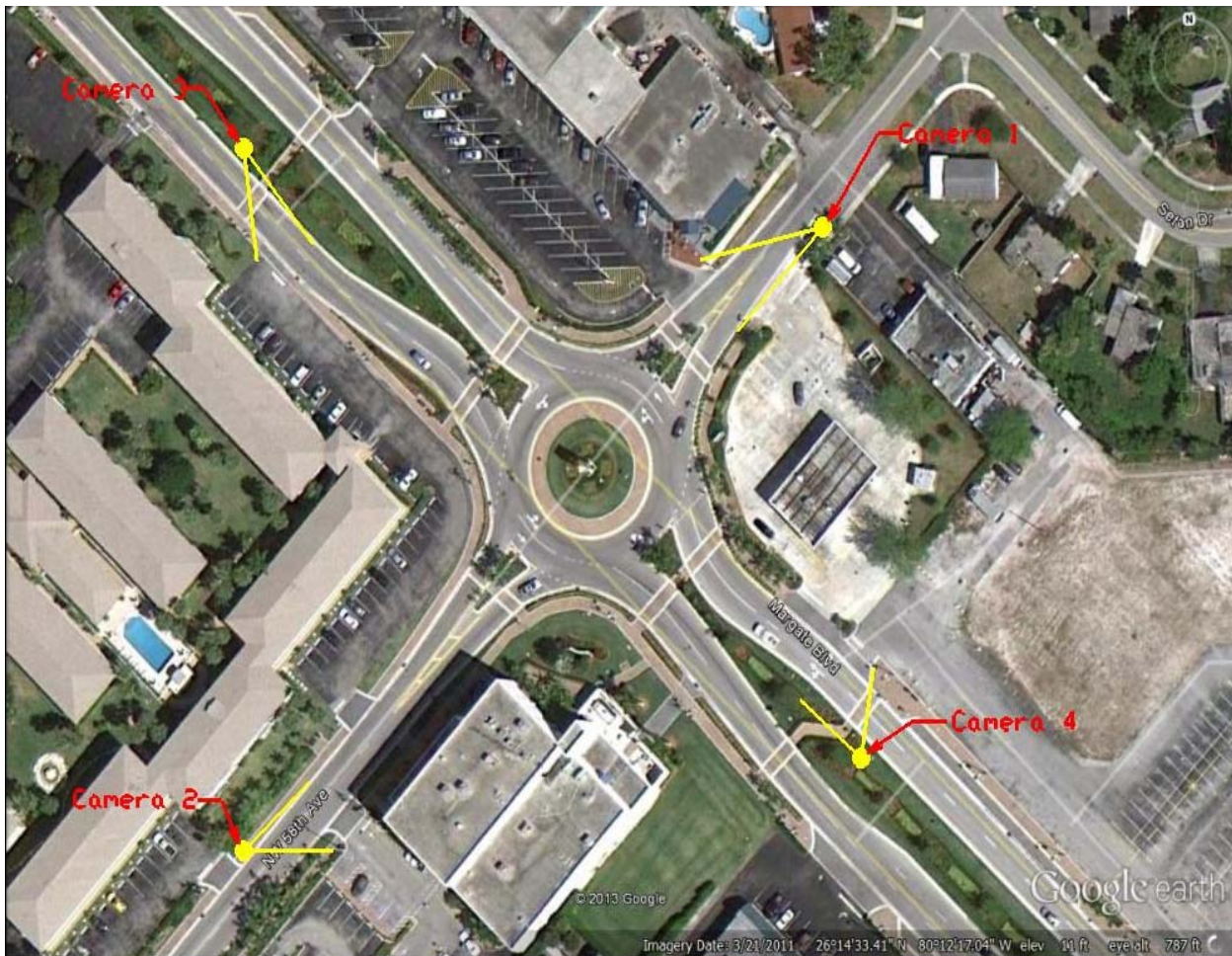

Figure D.13. Camera Location of Roundabout at Margate Blvd. and NW 58th St.