



## **FINAL REPORT**

|   |
|---|
| <p><b>SITE PREPARATION FOR A DEEP FOUNDATION<br/>TEST SITE AT THE UNIVERSITY OF CENTRAL FLORIDA</b></p> |
|---|

**CONTRACT NUMBER: BC355\RWPO #5**

Research Organization: Department of Civil and Environmental Engineering  
University of Central Florida  
PO 162450, Dept of Civil and Environ Engineering  
4000 Central Florida Boulevard  
Orlando, FL 32816-2450

Principal Investigator: **Manoj Chopra, Ph.D., P.E.**  
Department of Civil and Environmental Engineering  
211 Engineering Building II  
University of Central Florida  
Orlando, Florida 32816-2450  
Email: chopra@mail.ucf.edu  
Phone: (407) 823-2841

Project Manager: **David Horhota, Ph.D., P.E.**  
Florida Department of Transportation

January 2003

## Table of Contents

|                                 |   |
|---------------------------------|---|
| Project Objectives .....        | 3 |
| Completed Tasks .....           | 3 |
| Potential Research Topics ..... | 4 |

## **PROJECT OBJECTIVES**

The objective of this research project was to prepare a deep foundation test site on the grounds of the University of Central Florida. This test site will be used for on-going and recurring testing for research and certification programs.

It will be utilized to demonstrate various pile and drilled shafts, compare various load test methods such as (i) Conventional static load test (ASTM 1143), (ii) Osterberg (O) cell, (iii) Statnamic, and (iv) Wave equation (ASTM 4945) – PDA / CAPWAP. The results from the field tests may also be used to compare various analysis methods. No such field test site exists in Florida and the results from the associated research may be useful in documenting newer pile types and construction methods for soils in Florida soils. In addition, the site will be utilized for the training of FDOT personnel in deep foundation installation and testing methods.

## **COMPLETED TASKS**

***Task 1a Site Preparation*** – *The initial preparation of the test site will involve a detailed survey of the site and the clearing and grubbing of the site. In the first phase of this project, the two-acre site will be cleared.*

A site was selected along the east boundary of the University of Central Florida as shown in Figure 1. The site was cleared and grubbed in October 2001. All debris was removed and the site was graded level. The cost for this part of the project was \$8650.

### ***Task 1b Installation of a Fence***

Since the preparation of the site in Task 1 above was successfully completed under the budgeted amount, it was determined that the entire 2-acre site would be fenced. This would enhance the privacy at the site and give a more professional working environment.

Therefore, in November 2001, a galvanized chain link fence and posts were installed to surround site. The length of the fence is 1,156 feet. It contains one 24 feet wide opening with two 12 feet wide swing gates. This project was completed at a cost of \$9600.

### ***Task 2 Access Road Improvement***

It was determined that this task should be undertaken closer to the actual period for deep foundation installation. As such, the remaining funds in

this project will be set aside in a balance account to complete the road improvement when the installation projects commence.

***Task 3 Earthwork and Compaction*** – *The site will be prepared for research projects involving installation and testing of piles and drilled shafts. A staging area for equipment will be developed which will be used to launch most project work.*

The site was graded and is currently very level. It does not have any loose soils and the subcontractor from the University of Florida, who performed the site investigation, have indicated that there was no difficulty in working at the site with the SPT and cone penetrometer rigs.

***Task 4 Coordination of Site Characterization Activities on the Site*** – *The University of Florida at Gainesville has prepared a proposal for performing certain in-situ testing. UCF will extend all possible cooperation and coordinate all activities at the proposed deep foundation test site.*

The University of Florida at Gainesville has prepared report based on the in-situ testing performed at the site for a subcontract to this project (Contract Number 4910 45-04-875). The report for the subcontract dealing with the site characterization task is attached in the Appendix.

***Task 5 Preparation of Site Surveys -***

An initial survey of the site was conducted in July 2001 to determine the location of the site. It showed the four corners and the boundary of the site. This survey is attached as Figure 2.

Upon completion of all the site investigation activities, it was determined that an accurate survey of the site was needed to document the locations of the various tests, namely, SPTs, CPTs, DMTs and others. This second survey was conducted in August 2002 and is attached as Figure 3.

## **POTENTIAL RESEARCH TOPICS**

Two meetings were held to discuss potential uses of the UCF/FDOT site. The first meeting took place in Orlando in May 2002 and the second in Gainesville in November 2002. The meetings were attended by representatives from the FDOT State Materials office, faculty members from different Florida universities and other interested parties.

The following is a summary of the discussions and potential ideas that may be implemented at the site.

## General Notes

- Extend the scope of the site to encompass other geotechnical engineering research areas.
- Subdivide the site into different zones (2-3) based on similar soil types and nature of research projects.
- Transport and house FDOT static load test equipment at the site.

## Potential Research Ideas - Drilled Shafts

- Load Test Comparisons (O-Cell, Static, Statnamic, GRL-Apple)
- Construction Techniques
  - Slurry / Time in Hole
  - Casings
  - Concrete Mixes
- Instrumentation
  - Fiber-Optic Sensors for Pressures
  - Wireless Sensors
- Residual Stresses
- Integrity Testing
  - Profiling
  - Downhole Camera
  - Shaft Modulus
- Design Issues
- Constructability Issues
- Freeze – Staged testing
- Torsion and Lateral Behavior

## Potential Research Ideas - Piles

- Load Tests (O-Cell, Static, Statnamic, Apple)
- Pile Splicing Testing
- LRFD Factors with Spatial, Equipment and Design Variability Issues
- Instrumentation
  - Fiber-Optic Sensors for Pressures
  - Embedded Strain Gauges
- Constructability Issues using Synthetic Slurries
- Torsional and Lateral Behavior
- Pore Pressures on Pile Face during Driving and Subsequent Dissipation
- Jetting and Pre-Drilling
- Pile Friction Freeze

## Potential Research Ideas – Geotechnical Issues

- SPT Standardization Tests with Different Rigs and Methods
- Developing Standard Format for Reporting Geotechnical Data

As a result of these meetings, it was determined that a master plan be developed for the use of the site which incorporates the different types of deep foundations, related instrumentation and various tests to be performed. In particular, this master plan is needed for the proper sequencing of events at the site to ensure optimum use of the limited land mass.

Under the leadership of Dr. Frank Townsend at the University of Florida, a proposal will be developed to develop this plan and begin the initial phase of installation and testing at the site.



Figure 1 - UCF/FDOT Test Site at the University of Central Florida



Figure 2 - Initial Site Survey to show Boundary of Test Site



# APPENDIX

Report on Site Characterization performed by the University of Florida

# FINAL REPORT

## Site Preparation for a Deep Foundation Test Site at the University of Central Florida

Submitted by  
F. C. Townsend  
J. Brian Anderson  
Evelio Horta

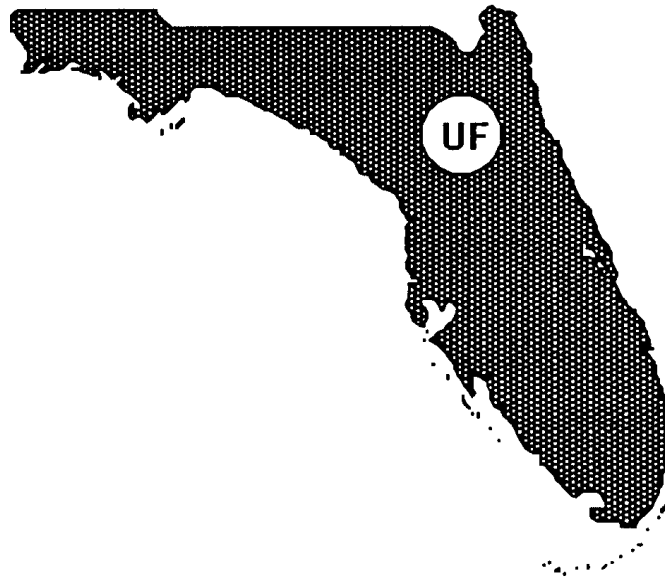

Submitted to: **The University of Central Florida and Florida Department of Transportation**

UCF Prime Contract BC355\RWPO #5

UF Contract No. 4910 45-04-875

September 2002

|   |  |   |  |                               |           |
|---|--|---|--|-------------------------------|-----------|
| 1. Report No.   |  | 2. Government Accession No.                                 |  | 3. Recipient's Catalog No.    |           |
| 4. Title and Subtitle<br><b>Site Preparation for a Deep Foundation Test Site at the University of Central Florida</b>   |  |   | 5. Report Date<br><b>September 2002</b>  |                               |           |
|   |  |   | 6. Performing Organization Code  |                               |           |
| 7. Author(s)  |  |   | 8. Performing Organization Report No.<br>UCF Prime Contract BC355\RWPO #5                        |                               |           |
| 9. Performing Organization Name and Address<br><b>University of Florida<br/>Department of Civil &amp; Coastal Engineering<br/>124 Yon Hall / P.O. Box 116580<br/>Gainesville, FL 32611-6580</b>   |  |   | 10. Work Unit No. (TRAIS)  |                               |           |
|   |  |   | 11. Contract or Grant No.  |                               |           |
| 12. Sponsoring Agency Name and Address<br><b>Florida Department of Transportation<br/>Research Management Center<br/>605 Suwannee Street, MS 30<br/>Tallahassee, FL 32301-8064</b>  |  |   | 13. Type of Report and Period Covered<br><b>Final Report<br/>September 2001 – September 2002</b> |                               |           |
|   |  |   | 14. Sponsoring Agency Code   |                               |           |
| 15. Supplementary Notes<br><b>Prepared as a subcontract to UCF Prime BC355/RPWO#5</b>   |  |   |  |                               |           |
| 16. Abstract<br><p>An experimental test site located at the University of Central Florida (UCF), Orlando has been selected for evaluating deep foundations. The 300 ft. by 300 ft. test site has been cleared, and fenced. The objective of this site characterization program was to provide a comprehensive suite of insitu tests for future evaluation of axial and lateral capacities of deep foundations. The scope of work consisted of: five SPT, seventeen CPT, four DMT, and two PMT soundings. Inasmuch as the SPT is the most common insitu test, comparisons were made between; (1) drilling operators, (2) hammer type (safety vs. automatic), and (3) cased vs. drilling mudded holes. Energy measurements were also conducted to compare the SPT data.</p> <p>The generalized soil profile from SPT borings is: (1) 0-5 ft. medium sand, (2) 5-33 ft. sand-silty sand, (3) 33-52 ft. silty clay – clay, (4) 52-60 ft. medium cemented sand. From the center eastward a hard pan sand layer exists from about 10 to 15 ft.</p> <p>Comparisons between SPT borings using a hollow stem auger vs. a cased hole using an automatic trip hammer revealed little difference in N values. SPT energy measurements gave energy measurements of 82% for an automatic hammer, and only 65% for a safety hammer. Comparisons between DMT borings using three different agencies revealed consistent results with little variation between agencies. PMT measurements between two different agencies revealed substantial differences. These differences are attributed primarily to an oversized friction reducer on the tip, which caused an oversized hole and subsequent near hole disturbance leading to a softer response.</p> |  |   |  |                               |           |
| 17. Kev Words<br><b>Insitu Testing, Standard Penetration Test. Cone Penetrometer Tests, Dilatometer Tests, Pressuremeter Tests</b>  |  |   | 18. Distribution Statement<br><b>No restrictions.</b>  |                               |           |
| 19. Security Classif. (of this report)<br><b>Unclassified</b>   |  | 20. Security Classif. (of this page)<br><b>Unclassified</b> |  | 21. No. of Pages<br><b>70</b> | 22. Price |

## TABLE OF CONTENTS

|  | <u>page</u> |
|--|-------------|
| LIST OF TABLES .....   | ii          |
| LIST OF FIGURES .....  | iii         |
| <br>SECTION  |             |
| 1 INTRODUCTION.....  | 1           |
| 2 INSITU TEST LAYOUT .....   | 3           |
| 3 STANDARD PENETRATION TEST BORING LOGS .....                        | 3           |
| 4 GRAIN SIZE DISTRIBUTION .....                                      | 3           |
| 5 GROUND WATER LEVEL.....  | 11          |
| 6 STANDARD PENETRATION TEST WITH ENERGY MEASUREMENTS.....            | 11          |
| 6.1 Group East.....  | 11          |
| 6.2 Group West.....  | 12          |
| 6.3 All SPT Borings .....  | 14          |
| 7 DILATOMETER TEST (DMT) .....                                       | 14          |
| 7.1 Data Comparison Between UF, SMO and District 1 Dilatometers..... | 14          |
| 7.2 DMT Results .....  | 14          |
| 8 STANDARD PENCEL PRESSUREMETER (PMT).....                           | 18          |
| 8.1 Results .....  | 18          |
| 9 CONE PENETRATION TEST (CPT) .....                                  | 22          |
| 10 SOIL PROFILE.....   | 32          |
| 11 CONCLUSIONS .....   | 41          |
| 12 ADDITIONAL DATA .....   | 41          |
| <br>APPENDIX   |             |
| Standard Penetration Test (SPT) Boring Logs.....                     | 48          |

## LIST OF TABLES

| <u>Table</u> |  | <u>Page</u> |
|--------------|--|-------------|
| 1            | Summary of Testing Program and Responsible Agency..... | 1           |
| 2            | Grain Size Distribution Bartow SPT 1 .....             | 6           |
| 3            | Grain Size Distribution Bartow SPT 2 .....             | 7           |
| 4            | Grain Size Distribution Universal SPT 1 .....          | 8           |
| 5            | Grain Size Distribution Universal SPT 2 .....          | 9           |
| 6            | Grain Size Distribution Nodarse SPT 1 .....            | 10          |
| 7            | SPT Analyzer Data Group East.....                      | 11          |
| 8            | SPT Analyzer Data Group West .....                     | 14          |

## LIST OF FIGURES

| <u>Figure</u>   | <u>Page</u> |
|---|-------------|
| 1 Aerial View of the UCF Research Site .....  | 2           |
| 2 Boring and Sounding Plan.....   | 4           |
| 3 Plan View of the Site with the Exact Location of the Tests Performed.....                               | 5           |
| 4 Energy Analysis SPT Group East .....  | 12          |
| 5 Energy Analysis SPT Group West.....   | 13          |
| 6 Summary of 5 SPT Borings at UCF Test Site.....  | 15          |
| 7 Generalized Site Stratigraphy from 5 SPT Tests.....   | 16          |
| 8 DMT Results for UF DMT 1 and SMO Located at East Group of SPT Tests.....                                | 17          |
| 9 DMT Results for UF DMT 2 and FDOT District 1 Located at West Group<br>of SPT Tests .....                | 18          |
| 10 Comparison Graph of Data Interpretation from UF and SMO<br>Pressuremeter at Depth 5 Feet.....          | 19          |
| 11 Comparison Graph of Data Interpretation from UF and SMO<br>Pressuremeter at Depth 10 Feet.....         | 19          |
| 12 Comparison Graph of Data Interpretation from UF and SMO<br>Pressuremeter at Depth 15 Feet.....         | 20          |
| 13 Comparison Graph of Data Interpretation from UF and SMO<br>Pressuremeter at Depth 20 Feet.....         | 20          |
| 14 Comparison Graph of Data Interpretation from UF and SMO<br>Pressuremeter at Depth 25 Feet.....         | 21          |
| 15 Comparison Graph of Data Interpretation from UF and SMO<br>Pressuremeter at Depth 30 Feet.....         | 21          |
| 16 Comparison Graph of Data Interpretation from UF and SMO<br>Pressuremeter at Depth 35 Feet.....         | 22          |
| 17 CPT Soundings at NE Corner Location 1 .....  | 23          |
| 18 CPT Soundings at NW Corner Location 2.....   | 24          |
| 19 CPT Soundings at SW Corner Location 3.....   | 25          |
| 20 CPT Soundings at SW Corner Location 4.....   | 26          |
| 21 CPT Soundings at Center Location 5 .....   | 27          |
| 22 CPT Soundings at South Location 6 (South Center).....  | 28          |
| 23 CPT Soundings Cross Section Show Increasing Tip Resistance Along<br>SW to SE Portion of the Site ..... | 29          |
| 24 CPT Soundings Show Increasing Tip Resistance Along<br>NW to SE Cross Section of the Site.....          | 30          |
| 25 CPT Soundings Show Increasing Tip Resistance Along<br>SW to NE Cross Section of the Site.....          | 31          |
| 26 Relative Location for the CPT, SPT and DMT Borings Performed at the Site.....                          | 33          |
| 27 3D View of the Site Looking North from SE Corner.....  | 34          |
| 28 3D View of the Site Looking South from NW Corner.....  | 35          |
| 29 Two Cross Sections of the Site (A and B).....  | 36          |
| 30 Two Cross Sections of the Site (A and E).....  | 37          |
| 31 Three Cross Sections of the Site (B, C and D).....   | 38          |
| 32 General Tip Resistance Characterization of the Site.....   | 39          |
| 33 Closer Look at the Change on Tip Resistance Between the<br>“Hard” NE Corner and “Soft” SW Corner.....  | 40          |

|    |   |    |
|----|---|----|
| 34 | Overhead view at depth of 5 ft .....                | 41 |
| 35 | Overhead view at depth of 5 ft from SE corner ..... | 42 |
| 36 | Overhead view at depth of 15 ft .....               | 43 |
| 37 | Overhead view at depth of 30 ft. ....               | 44 |
| 38 | Overhead view at a depth of 45 ft. ....             | 45 |
| 39 | Overhead view at a depth of 50 ft. ....             | 46 |

# 1. INTRODUCTION, PURPOSE, AND SCOPE OF WORK

Site characterization is the preliminary phase in foundation selection and design. An experimental test site located in the proximity of the University of Central Florida (UCF), Orlando has been selected for evaluating deep foundations. The test site is about 300 feet by 300 feet, has been cleared of trees and bushes, and is protected with a fence. Topographically, the lot is flat and there are no significant differences in elevation through the site. Figure 1 is an aerial view of the research site.

Considering that the test site is to be used for evaluating deep foundations, the objective of the site characterization program was to provide a comprehensive suite of insitu tests for future evaluation of axial and lateral capacities of deep foundations.

The scope of work to accomplish this objective was to perform conventional characterization tests; i.e., SPT, CPT, DMT, and PMT. Inasmuch as the SPT is the most common insitu test, comparison were made between; (1) drilling operators, (2) hammer type (safety vs. auto-matic), and (3) cased vs. drilling mudded holes. Energy measurements were also conducted to compare the SPT data. Energy measurements were performed by GRL and FDOT (SMO), Gainesville.

To evaluate operator effects, the following testing matrix was used:

1. SPT tests used commercial drillers; (a) Nodarse and Assoc., and (b) Universal Testing, and FDOT drillers from District 1 – Bartow
2. FDOT State Materials Office (SMO), the University of Florida (UF), and Ardaman and Associates (mini-cone) performed CPT tests
3. DMT tests were performed by FDOT District1, FODT – SMO, and UF
4. PMT tests were performed by FDOT – SMO and UF.

Table 1 summarizes the testing program and agencies involved.

Table 1. Summary of Testing Program and Responsible Agency

| Test Type Agency     | SPT | CPT | DMT | PMT | Energy Measurement Performed |
|----------------------|-----|-----|-----|-----|------------------------------|
| Nodarse              | 1   |     |     |     |                              |
| Universal            | 2   |     |     |     |                              |
| Ardaman              |     | 2   |     |     |                              |
| FDOT SMO Gainesville |     | 5   | 1   |     | 4                            |
| FDOT Dist 1 Bartow   | 2   | 5   | 1   | 1   |                              |
| UF                   |     | 5   | 2   | 1   |                              |
| GRL                  |     |     |     |     | 5                            |



Figure 1. Aerial View of the UCF Research Site

## **2. INSITU TEST LAYOUT**

In order to obtain a well-characterized soil profile a total of twenty-eight well-known soil insitu tests were performed at several locations throughout the site. Special attention was given to the corners and center of the property, leaving a minimum of untested spots. In order to avoid disturbance of material due to the proximity of equipment a minimum safe distance was kept at all times between the different equipments. See pictures of testing in attached CD. Figure 2 presents a plan view of the site, and relative location of the test and which Agency performed it. Figure 3 presents the survey results and co-ordinates.

## **3. STANDARD PENETRATION TEST BORINGS LOGS**

The exploration program consisted of initially performing five (5) Standard Penetration Test (SPT) borings. Subsequently, 2 borings to 200 ft. were performed; one in the “hard’ NE corner, and the other in the “soft” SW corner. Shelby tube samples were taken from these latter 2 borings. The results of the field exploration, description of the soil type, N values, and depth of exploration at each boring location are graphically summarized on the soil profiles presented in the Appendix (see boring logs SPT 1 to SPT 5).

The SPT borings were performed at the approximate locations shown in our boring location plan (Figure 2). The borings were advanced to a depth of 60 feet below the ground surface. Split-spoon soil samples recovered during performance of the boring were visually classified in the field and representative portions of the samples were transported to FDOT-SMO laboratory in sealed sample jars for classification.

The two commercial SPT rigs (Nodarse and Universal) used a safety hammer, while FDOT District 1-Bartow used an automatic hammer.

## **4. GRAIN SIZE DISTRIBUTION**

The FDOT-SMO and UF Labs performed visual classification and sieve analysis, on samples retrieved from the SPT soil borings. With the exception of the FDOT District 1- Bartow rig, the rest of the rigs performed continuous sampling of the soil from the surface to the depth of 10 feet. From the depth of 10 feet to the end of boring samples were taken every 5 feet. In general the information obtained from the sieve analysis at the lab, confirmed visual description of the stratification show on the boring logs SPT 1 to SPT 5. The generalized soil profile is as follows:

- from 0–5 feet a Medium Sand;
- from 5–33 feet Sand to Silty Sand;
- from 33–52 feet Silt Clay to Clay Silt; and
- from 52–60 feet Medium Cemented Sand (Gravelly Sand).

Tables 2–6 present the sieve analysis results provided by FDOT-SMO laboratory.

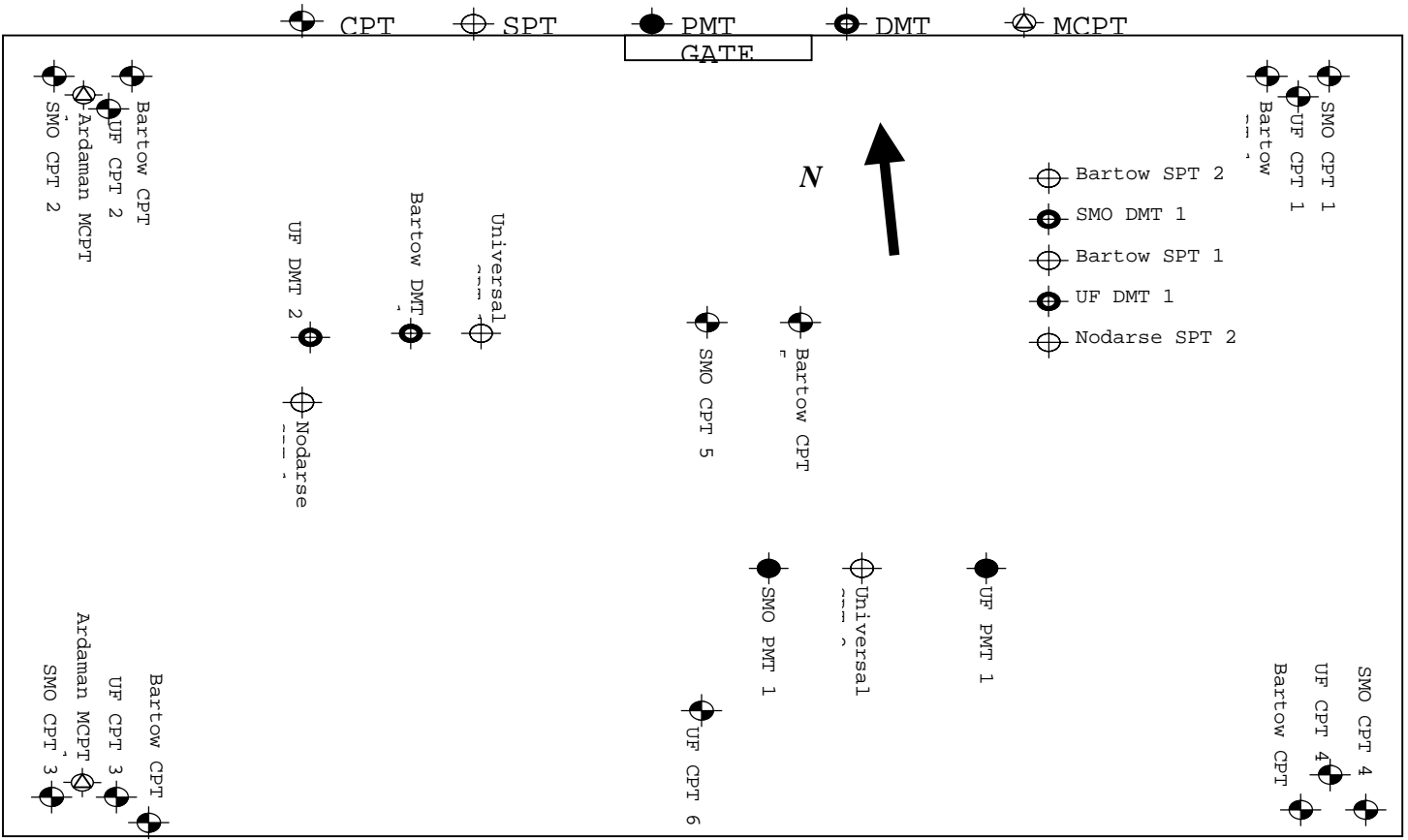

Figure 2. Boring and Sounding Plan

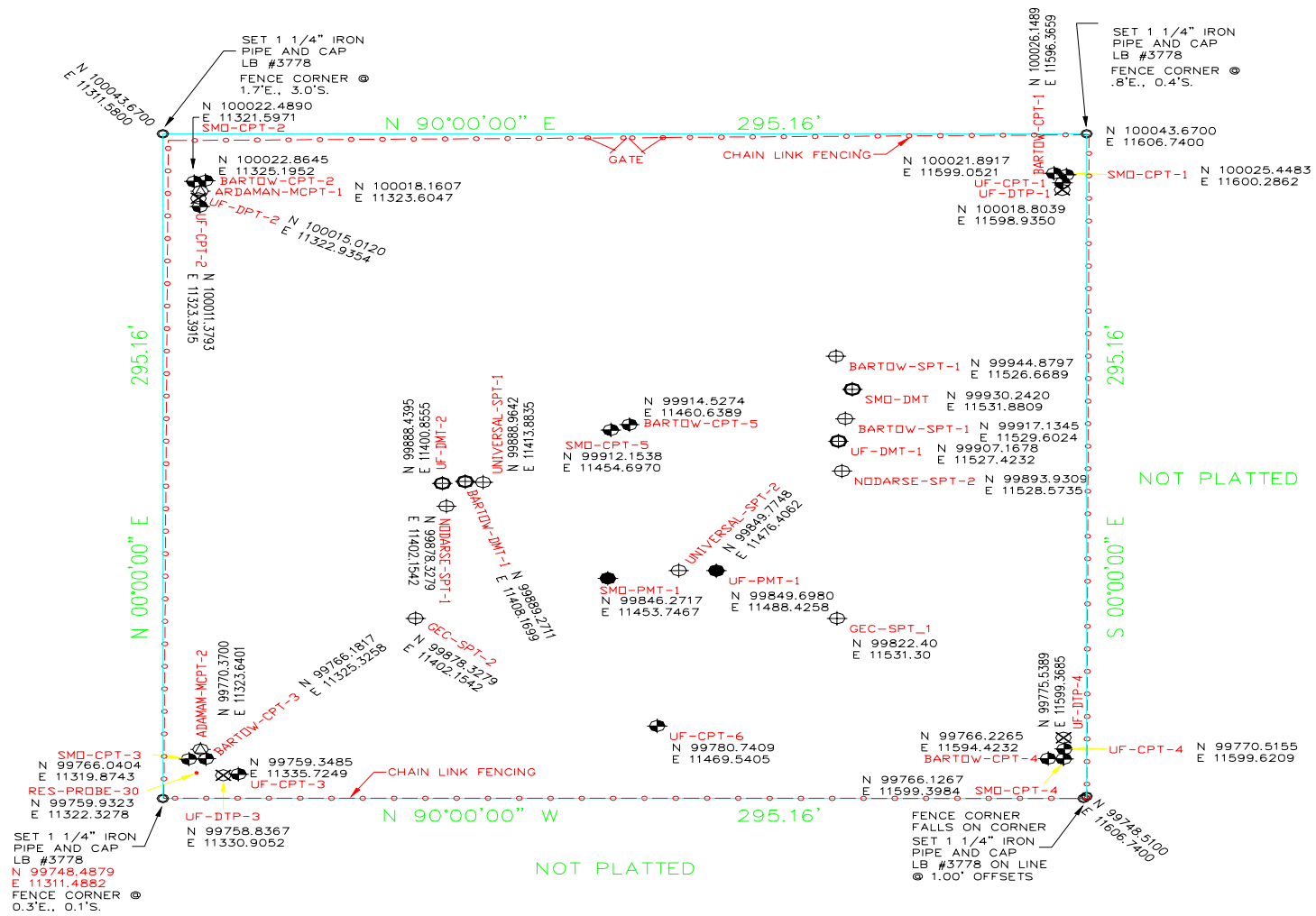

Figure 3. Plan View of the Site with the Exact Location of the Tests Performed

Table 2. Grain Size Distribution Bartow SPT 1

samples logged in 2/5/02

| Boring No. | Sample No. | Depth     | % moisture | organic content (%) | AASHTO class. | Unified class. | passing 1/2 | passing 3/8 | passing #4 | passing #10 | passing #40 | passing #60 | passing #200 | % clay | % silt | % sand | LL/PI (%) |
|------------|------------|-----------|------------|---------------------|---------------|----------------|-------------|-------------|------------|-------------|-------------|-------------|--------------|--------|--------|--------|-----------|
| 1          | 1          | 0-1.5     | 6.2        |                     | A-3           | SP             |             |             |            | 100         | 98          | 87          | 3            |        |        |        |           |
| 1          | 2          | 5.0-6.5   | 38.8       | 1.0                 | A-3           | SP             |             |             |            | 100         | 97          | 84          | 3            |        |        |        |           |
| 1          | 3          | 10.0-11.5 | 25.1       |                     | A-2-4         | SM             |             |             |            | 100         | 99          | 96          | 18           |        |        |        |           |
| 1          | 4A         | 15.0-16.5 | 28.0       |                     | A-2-4         | SM             |             |             |            | 100         | 99          | 98          | 19           |        |        |        |           |
| 1          | 4B         | 16.5-18.0 | 28.9       |                     | A-2-4         | SM             |             |             |            | 100         | 100         | 99          | 15           |        |        |        |           |
| 1          | 5          | 20.0-21.5 | 28.4       |                     | A-4           | SM             |             |             |            | 100         | 100         | 99          | 46           | 19     | 27     | 54     | NP        |
| 1          | 6          | 25.0-26.5 | 26.9       |                     | A-3           | SP-SM          |             |             |            | 100         | 99          | 95          | 7            |        |        |        |           |
| 1          | 7          | 30.0-31.5 | 30.3       |                     | A-2-4         | SM             |             |             |            | 100         | 100         | 99          | 16           |        |        |        |           |
| 1          | 8          | 35.0-36.5 | 37.0       | 3.7                 | A-4           | CL             |             |             |            | 100         | 99          | 99          | 51           | 21     | 30     | 49     | 31/ 9     |
| 1          | 9          | 40.0-41.5 | 31.1       |                     | A-2-4         | SM             |             |             |            | 100         | 99          | 91          | 35           | 12     | 23     | 65     | NP        |
| 1          | 10         | 45.0-46.5 | 28.0       |                     | A-4           | SC             |             |             |            | 100         | 99          | 97          | 39           | 17     | 22     | 61     | 23/ 7     |
| 1          | 11         | 50.0-51.5 | 30.8       |                     | A-6           | SC             | 97          | 94          | 85         | 85          | 81          | 78          | 43           | 16     | 27     | 57     | 31/ 13    |
| 1          | 12         | 55.0-56.5 | 21.5       |                     | A-1-B         | SP-SM          | 94          | 93          | 88         | 77          | 36          | 24          | 6            |        |        |        |           |
| 1          | 13         | 60.0-61.5 | 23.0       |                     | A-1-B         | SP             | 86          | 79          | 64         | 54          | 31          | 20          | 4            |        |        |        |           |

Table 3. Grain Size Distribution Bartow SPT 2

| Boring No. | Sample No. | Depth     | % moisture | organic content (%) | AASHTO class. | Unified class. | passing 1/2 | passing 3/8 | passing #4 | passing #10 | passing #40 | passing #60 | passing #200 | % clay | % silt | % sand | LL/PI (%) |
|------------|------------|-----------|------------|---------------------|---------------|----------------|-------------|-------------|------------|-------------|-------------|-------------|--------------|--------|--------|--------|-----------|
| 2          | 1          | 0-1.5     | 5.9        |                     | A-3           | SP             |             |             |            | 100         | 97          | 85          | 4            |        |        |        |           |
| 2          | 2          | 5.0-6.5   | 23.7       | 1.2                 | A-3           | SP             |             |             |            | 100         | 96          | 84          | 4            |        |        |        |           |
| 2          | 3          | 10.0-11.5 | 22.4       |                     | A-2-4         | SM             |             |             |            | 100         | 99          | 94          | 19           |        |        |        | NP        |
| 2          | 4          | 15.0-16.5 | 26.6       |                     | A-2-4         | SM             |             |             |            | 100         | 100         | 100         | 21           |        |        |        |           |
| 2          | 5          | 20.0-21.5 | 27.6       |                     | A-2-4         | SM             |             |             |            | 100         | 100         | 99          | 34           | 14     | 20     | 66     | NP        |
| 2          | 6          | 25.0-26.5 | 25.1       |                     | A-2-4         | SM             |             |             |            | 100         | 97          | 91          | 14           |        |        |        |           |
| 2          | 7          | 30.0-31.5 | 28.2       |                     | A-2-4         | SP-SM          |             |             |            | 100         | 99          | 98          | 11           |        |        |        |           |
| 2          | 8          | 35.0-36.5 | 30.2       |                     | A-4           | SM             |             |             |            | 100         | 100         | 98          | 42           | 18     | 24     | 58     | NP        |
| 2          | 9          | 40.0-41.5 | 31.6       |                     | A-2-4         | SM             |             |             |            | 100         | 99          | 92          | 22           | 13     | 9      | 78     | NP        |

Table 4. Grain Size Distribution Universal SPT 1

samples logged in 4/23/02

| Bor. No. | Samp. No. | Depth     | Tare  | wt. weight + tare | dry weight + tare | % moist. | organic content (%) | AASHTO class. | Unified class. | pass. 3/4 | pass. 1/2 | pass. 3/8 | pass. #4 | pass. #10 | pass. #40 | pass. #60 | pass. #200 | % clay | % silt | % sand | LL/PI (%) |
|----------|-----------|-----------|-------|-------------------|-------------------|----------|---------------------|---------------|----------------|-----------|-----------|-----------|----------|-----------|-----------|-----------|------------|--------|--------|--------|-----------|
| 1        | 1         | 1.0-2.5   | 373.0 | 511.9             | 500.0             | 9.4      |                     | A-3           | SP-SM          |           |           |           |          | 100       | 98        | 87        | 5          |        |        |        |           |
|          | 2         | 2.5-4.0   | 366.0 | 517.4             | 494.8             | 17.5     |                     | A-3           | SP             |           |           |           |          | 100       | 97        | 87        | 3          |        |        |        |           |
|          | 3         | 4.0-5.5   | 304.8 | 417.7             | 398.4             | 20.6     |                     | A-2-4         | SM             |           |           |           |          | 100       | 98        | 88        | 13         |        |        |        |           |
|          | 4         | 5.5-7.0   | 305.0 | 413.6             | 395.3             | 20.3     | 2.6                 | A-3           | SP-SM          |           |           |           |          | 100       | 97        | 89        | 10         |        |        |        |           |
|          | 5         | 7.0-8.5   | 313.0 | 404.8             | 391.7             | 16.6     |                     | A-2-4         | SM             |           |           |           |          | 100       | 100       | 99        | 20         |        |        |        |           |
|          | 6         | 8.5-10.0  | 304.7 | 480.3             | 450.7             | 20.3     |                     | A-2-4         | SM             |           |           |           |          | 100       | 100       | 98        | 23         |        |        |        |           |
|          | 7         | 13.0-14.5 | 371.4 | 510.9             | 482.5             | 25.6     |                     | A-3           | SP-SM          |           |           |           |          | 100       | 100       | 99        | 10         |        |        |        |           |
|          | 8         | 17.0-18.5 | 366.7 | 515.1             | 469.8             | 43.9     |                     | A-2-4         | SM             |           |           |           |          | 100       | 100       | 99        | 15         |        |        |        |           |
|          | 9         | 23.0-24.5 | 308.9 | 511.8             | 488.9             | 12.7     |                     | A-3           | SP-SM          |           |           |           |          | 100       | 97        | 86        | 6          |        |        |        |           |
|          | 10        | 27.0-28.5 | 298.7 | 340.4             | 329.8             | 34.1     |                     |               |                |           |           |           |          | 100       | 100       | 100       | 47         | 14     | 33     | 53     |           |
|          | 11        | 33.0-34.5 | 368.1 | 441.3             | 420.8             | 38.9     |                     | A-2-4         | SM             |           |           |           |          | 100       | 97        | 89        | 14         |        |        |        |           |
|          | 12*       | 38.0-39.5 | 328.3 | 505.4             | 450.3             | 45.2     |                     | A-6           | CL             |           |           |           |          | 100       | 100       | 100       | 68         | 18     | 50     | 32     | 38/14     |
|          | 13        | 43.0-44.5 | 427.5 | 472.8             | 462.5             | 29.4     |                     | A-6           | SC             |           |           |           |          | 98        | 96        | 94        | 42         | 12     | 30     | 58     | 29/12     |
|          | 14*       | 48.0-49.5 | 363.4 | 576.6             | 521.5             | 34.9     |                     | A-4           | SC             |           |           |           |          | 89        | 82        | 78        | 46         | 14     | 32     | 54     | 30/10     |
|          | 16*       | 58.5-60.0 | 308.1 | 598.8             | 546.1             | 22.1     |                     | A-2-4         | SM             | 97        | 91        | 80        | 63       | 54        | 51        | 35        | 16         |        |        |        |           |

Table 5. Grain Size Distribution Universal SPT 2

| Bor. No. | Samp No. | Depth     | Tare  | wt. wt. + tare | dry wt. + tare | % moist. | organic content (%) | AASHTO class. | Unified class. | pass. 3/4 | pass. 1/2 | pass. 3/8 | pass. #4 | pass. #10 | pass. #40 | pass. #60 | pass. #200 | % clay | % silt | % sand | LL/PI (%) |
|----------|----------|-----------|-------|----------------|----------------|----------|---------------------|---------------|----------------|-----------|-----------|-----------|----------|-----------|-----------|-----------|------------|--------|--------|--------|-----------|
| 2        | 1        | 1.0-2.5   | 428.4 | 540.5          | 530.2          | 10.1     |                     | A-3           | SP             |           |           |           |          | 100       | 98        | 87        | 3          |        |        |        |           |
|          | 2        | 2.5-4.0   | 432.5 | 511.7          | 499.7          | 17.9     | 3.1                 | A-3           | SP-SM          |           |           |           |          | 100       | 98        | 87        | 6          |        |        |        |           |
|          | 3        | 4.0-5.5   | 428.2 | 479.8          | 473.0          | 15.2     |                     | A-2-4         | SM             |           |           |           |          | 100       | 96        | 84        | 14         |        |        |        |           |
|          | 4        | 5.5-7.0   | 432.0 | 553.2          | 537.5          | 14.9     |                     | A-2-4         | SM             |           |           |           |          | 100       | 96        | 82        | 19         |        |        |        |           |
|          | 5        | 7.0-8.5   | 432.5 | 552.1          | 533.8          | 18.1     |                     | A-2-4         | SM             |           |           |           |          | 100       | 96        | 80        | 13         |        |        |        |           |
|          | 6        | 8.5-10.0  | 431.3 | 533.6          | 516.6          | 19.9     | 2.6                 | A-3           | SP-SM          |           |           |           |          | 100       | 97        | 81        | 9          |        |        |        |           |
|          | 7        | 13.0-14.5 | 428.3 | 578.9          | 549.2          | 24.6     |                     | A-3           | SP             |           |           |           |          | 100       | 100       | 98        | 4          |        |        |        |           |
|          | 8        | 17.0-18.5 | 301.1 | 466.7          | 434.3          | 24.3     |                     | A-4           | SM             |           |           |           |          | 100       | 100       | 100       | 38         |        |        |        |           |
|          | 9        | 23.0-24.5 | 433.0 | 579.6          | 549.4          | 25.9     |                     | A-3           | SP-SM          |           |           |           |          | 100       | 100       | 97        | 7          |        |        |        |           |
|          | 10       | 27.0-28.5 | 431   | 574.5          | 542.8          | 28.4     |                     | A-2-4         | SM             |           |           |           |          | 100       | 100       | 100       | 27         |        |        |        |           |
|          | 11*      | 33.0-34.5 | 429.1 | 602.6          | 535.7          | 62.8     |                     | A-7-6         | CL             |           |           |           |          | 100       | 95        | 92        | 55         |        |        |        | 41/15     |
|          | 12*      | 38.0-39.5 | 431.1 | 600.7          | 550.8          | 41.7     |                     | A-4           | SC             |           |           |           |          | 100       | 99        | 98        | 45         | 15     | 30     | 55     | 31/10     |
|          | 13*      | 43.0-44.5 | 423.1 | 682.2          | 620.7          | 31.1     |                     |               |                |           |           |           |          | 100       | 99        | 99        | 36         | 14     | 22     | 64     |           |
|          | 14*      | 48.0-49.5 | 435.2 | 673.5          | 623.7          | 26.4     |                     | A-4           | SM             |           |           | 100       | 98       | 86        | 83        | 81        | 45         |        |        |        |           |
|          | 15*      | 53.0-54.5 | 431.1 | 769.1          | 702.8          | 24.4     |                     | A-1-B         | SM             | 95        | 93        | 91        | 83       | 58        | 40        | 33        | 14         |        |        |        |           |
|          | 16*      | 58.5-60.0 | 431.8 | 744.6          | 683.5          | 24.3     |                     | A-1-B         | SM             | 100       | 94        | 89        | 73       | 59        | 40        | 31        | 16         |        |        |        |           |

\* samples dried to constant weight in 110C oven

Table 6. Grain Size Distribution Nodarse SPT 1

samples logged in 5/7/02

| Bor. No. | Samp. No. | Depth     | % moist. | organic content (%) | AASHTO class. | Unified class.    | pass. 1" | pass. 3/4" | pass. 1/2" | pass. 3/8" | pass. #4 | pass. #10 | pass. #40 | pass. #60 | pass. #200 | % clay | % silt | % sand | LL/PI (%) |
|----------|-----------|-----------|----------|---------------------|---------------|-------------------|----------|------------|------------|------------|----------|-----------|-----------|-----------|------------|--------|--------|--------|-----------|
| 1        | 1         | 0.0-1.5   | 0.9      | 5.5                 | A-3           | SP-SM             |          |            |            |            |          | 100       | 97        | 85        | 6          |        |        |        |           |
|          | 2         | 1.5-3.0   | 8.6      |                     | A-3           | SP-SM             |          |            |            |            |          | 100       | 98        | 88        | 5          |        |        |        |           |
|          | 3         | 3.0-4.5   | 17.2     |                     | A-2-4         | SM                |          |            |            |            |          | 100       | 98        | 89        | 19         |        |        |        |           |
|          | 4         | 6.0-7.5   | 19.2     |                     | A-2-4         | SM                |          |            |            |            |          | 100       | 100       | 98        | 14         |        |        |        |           |
|          | 5         | 13.5-15.0 | 26.0     |                     | A-4           | SM                |          |            |            |            |          | 100       | 100       | 99        | 37         |        |        |        |           |
|          | 6         | 18.5-20.0 | 26.0     |                     | A-3           | SP-SM             |          |            |            |            |          | 100       | 99        | 94        | 6          |        |        |        |           |
|          | 7         | 23.5-25.0 | 28.5     |                     | A-2-4         | SM                |          |            |            |            |          | 100       | 100       | 100       | 21         |        |        |        |           |
|          | 8         | 28.5-30.0 | 33.8     |                     | A-4           | SM                |          |            |            |            |          | 100       | 100       | 99        | 41         | 15     | 26     | 59     | 28/2      |
|          | 9*        | 33.5-35.0 | 33.7     |                     | A-2-4         | SM                |          |            | 100        | 99         | 96       | 83        | 47        | 41        | 27         | 10     | 17     | 73     | NP        |
|          | 10*       | 38.5-40.0 | 64.0     |                     | A-7-5         | MH with sand      |          |            | 98         | 93         | 90       | 84        | 84        | 83        | 74         | 22     | 52     | 26     | 55/25     |
|          | 11*       | 43.5-45.0 | 47.6     |                     | A-6           | sandy-CL          |          |            |            | 97         | 96       | 95        | 95        | 94        | 66         | 16     | 50     | 34     | 40/16     |
|          | 12*       | 48.5-50.0 | 24.6     |                     | A-2-4         | SM                |          | 96         | 93         | 93         | 91       | 91        | 69        | 58        | 17         |        |        |        |           |
|          | 13*       | 53.5-55.0 | 29.4     |                     | A-2-4         | SM-with gravel    |          |            | 97         | 91         | 79       | 73        | 53        | 44        | 15         |        |        |        |           |
|          | 14*       | 58.5-60.0 | 13.8     |                     | A-1-b         | SP-SM-with gravel | 84       | 79         | 72         | 69         | 61       | 52        | 38        | 30        | 12         |        |        |        |           |

\* samples dried to constant weight in 110C oven

## 5. GROUND WATER LEVEL

Measurements of the ground water level at the site were taken from the boreholes on the day drilled after stabilization of the down hole water level. These levels were encountered at depths that range near 3 feet from the ground surface.

## 6. STANDARD PENETRATION TEST WITH ENERGY MEASUREMENTS

The SPT is the most common field test performed in Florida, and engineers are more comfortable with the data interpretation from this test. Due to the variability of the data obtained from one company even from one driller to other, the tests were performed on groups or very close to each other in order to perform comparisons of the blow counts at the same depth. To be able to measure test variability during drilling operations, the rigs were instrumented and variation of energy was measured.

### 6.1. Group East

Bartow SPT # 1 and # 2 are located on same area of the site on a straight-line heading North (see Figure 2). At the location of this group of borings the goal was to try to compare the use of hollow stem auger versus the use of casing to maintain an open hole. The same automatic hammer was used to perform both tests. As shown in the Figure 4, little difference between the boring results was found. The SPT-N blow count at the same depth is very similar, but the simultaneous energy measurements indicate substantial differences between the two borings. Both bore holes were drilled using an automatic hammer. Note that there may be errors associated with the energy measurements for Bartow SPT 1 by SMO due to a bad cable. GRL-PDI assisted with simultaneous measurements and assisted SMO personnel with troubleshooting the system (see Table 7).

Table 7. SPT Analyzer Data Group East

| Bartow SPT 1 |                                |                                | Bartow SPT 2 |                            |
|--------------|--------------------------------|--------------------------------|--------------|----------------------------|
| PDI          |                                | SMO                            | SMO          |                            |
| Depth (ft)   | SPT Analyzer Energy Rating (%) | SPT Analyzer Energy Rating (%) | Depth (ft)   | SPT Analyzer Energy Rating |
| 15           | 85.5                           | 79.1                           | 15           | 68.7                       |
| 30           | 81.9                           | 92.25                          | 30           | 68.7                       |
| 40           | 83.9                           | XX                             | 40           | 72.3                       |

| Agency       | Bartow 1      | Bartow 2 | Agency       | Bartow 1      | Bartow 2 |
|--------------|---------------|----------|--------------|---------------|----------|
| Depth (feet) | Blow counts N |          | Depth (feet) | Blow counts N |          |
| 0            | 0             | 0        | 20           | 3             | 6        |
| 0.5          |               |          | 25           | 17            | 20       |
| 1.5          | 4             | 7        | 30           | 4             | 4        |
| 3            |               |          | 35           | 0             | 3        |
| 5            | 14            | 20       | 40           | 0             | 1        |
| 7            |               |          | 45           | 4             |          |
| 8            |               |          | 50           | 7             |          |
| 10           | 23            | 22       | 55           | 16            |          |
| 15           | 7             | 8        | 60           | 50            |          |
| 17           | 7             |          |              |               |          |

Bartow 1  
Using casing to  
Depth 50'

Bartow 2  
Using Hollow  
Stem Auger

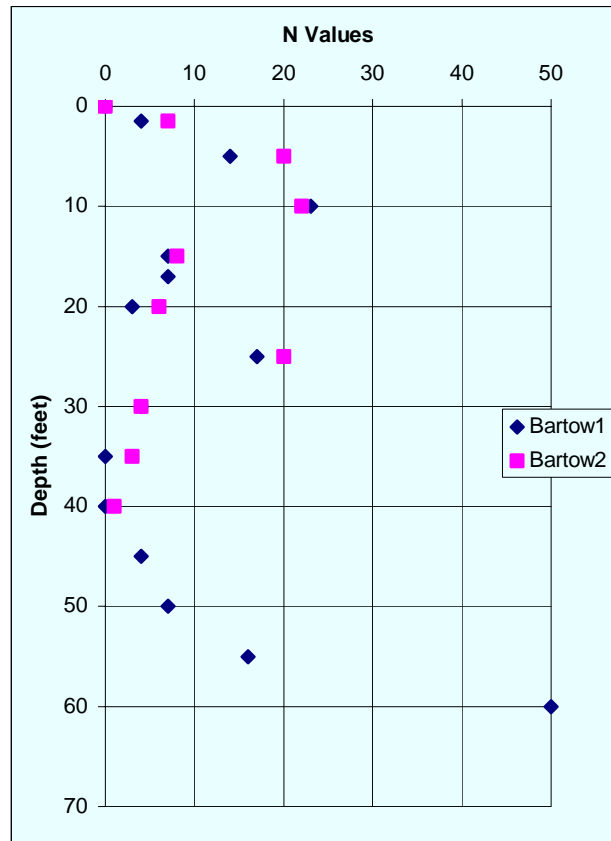
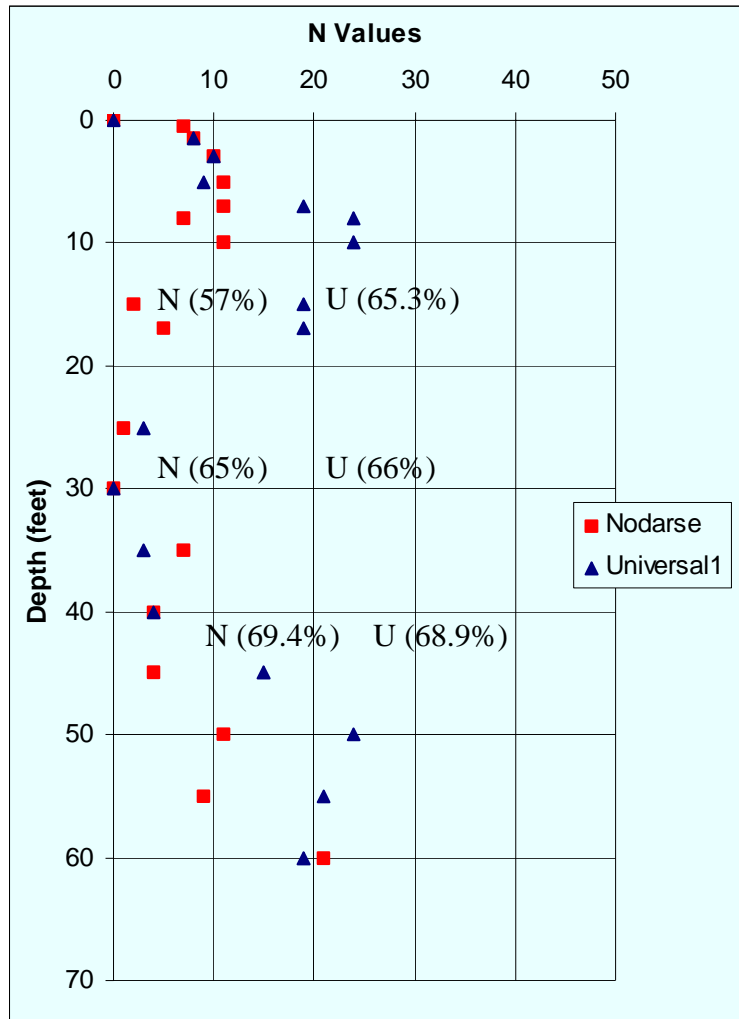

Figure 4. Energy Analysis SPT Group East

## 6.2. Group West

Universal SPT 1 versus Nodarse SPT 1 is located on a line from East to West (see Figure 2). At the location of this group the goal was to compare safety hammer performance of between two different companies/drill rigs. From the data shown in Figure 5, is possible to observe a difference of blow counts in the same layer of sand from depths of 8 to 25 feet. The Universal crew reported a higher blow count than Nodarse's crew. These results agree with the difference of energy measurement in this layer. See Table 8 below, where at 15 feet the energy measurement results are 57 % for Nodarse's rig and 65% for Universal's rig.

| Agency       | Nodarse       | Universal 1 | Agency       | Nodarse       | Universal 1 |
|--------------|---------------|-------------|--------------|---------------|-------------|
| Depth (feet) | Blow counts N |             | Depth (feet) | Blow counts N |             |
| 0            | 0             | 0           | 20           |               |             |
| 0.5          | 7             |             | 25           | 1             | 3           |
| 1.5          | 8             | 8           | 30           | 0             | 0           |
| 3            | 10            | 10          | 35           | 7             | 3           |
| 5            | 11            | 9           | 40           | 4             | 4           |
| 7            | 11            | 19          | 45           | 4             | 15          |
| 8            | 7             | 24          | 50           | 11            | 24          |
| 10           | 11            | 24          | 55           | 9             | 21          |
| 15           | 2             | 19          | 60           | 21            | 19          |
| 17           | 5             | 19          |              |               |             |



Note: An appreciable difference of N values exists between the SPT's from 8 to 17 feet. Probable cause is due to existence of hardpan layer located at this same depth. Both are mudded holes (Bentonite).

Figure 5. Energy Analysis SPT Group West

Table 8. SPT Analyzer Data Group West

| Nodarse SPT 1<br>PDI |                                      | Universal SPT 1<br>PDI |                                      |
|----------------------|--------------------------------------|------------------------|--------------------------------------|
| Depth<br>(ft)        | SPT Analyzer<br>Energy Rating<br>(%) | Depth<br>(ft)          | SPT Analyzer<br>Energy Rating<br>(%) |
| 15                   | 57                                   | 15                     | 65.3                                 |
| 30                   | 65                                   | 30                     | 66.2                                 |
| 40                   | 69.4                                 | 40                     | 68.9                                 |

### 6.3. All SPT Borings

Figure 6 presents a comparison of the N values obtained from the initial 5 SPT borings at the site. The figure illustrates that in spite of the local difference between N values at different depths, in general, these values yield a well-defined trend line. Based on the SPT test information the conclusion is that the area selected for the test is very uniform, showing a slight difference on the East and Center sides, where a hard pan sand layer is located at depths of 10 to 15 feet below grade.

Figure 7 is an interpretation for the general site stratigraphy, based on the 5 SPT test results.

## 7. DILATOMETER TEST (DMT)

A total of four DMT tests were performed at the site, using the UF, FDOT-SMO, and FDOT District 1 cone trucks. These tests were located near a SPT test in order to make a future comparison of data interpretation.

### 7.1. Data Comparison Between UF, SMO and District 1 Dilatometers

In order to make the comparison of data from UF DMT 1 and SMO DMT, the two borings were located relatively close to each other in the East Group of SPT tests. The same approach was also taken to compare UF's DMT 2 with District 1's DMT. These borings were located at the West Group of SPT tests (see Figure 2). The graphs in Figures 8 and 9 present results from the four DMT borings and establish a comparison at each group with the DMT results.

### 7.2. DMT Results

A comparison of the DMT data presented in Figures 8 and 9 show little difference between the plots. Consequently, there is little variation between the DMT equipment and data reduction thereof; i.e., reliable.

| Agency    | Bartow |    | Nodarse | Universal |    | Agency    | Bartow |    | Nodarse | Universal |    |
|-----------|--------|----|---------|-----------|----|-----------|--------|----|---------|-----------|----|
|           | 1      | 2  |         | 1         | 2  |           | 1      | 2  |         | 1         | 2  |
| Depth(ft) |        |    |         |           |    | Depth(ft) |        |    |         |           |    |
| 0         | 0      | 0  | 0       | 0         | 0  | 20        | 3      | 6  |         |           |    |
| 0.5       |        |    | 7       |           |    | 25        | 17     | 20 | 1       | 3         | 19 |
| 1.5       | 4      | 7  | 8       | 8         | 14 | 30        | 4      | 4  | 0       | 0         | 3  |
| 3         |        |    | 10      | 10        | 20 | 35        | 0      | 3  | 7       | 3         | 0  |
| 5         | 14     | 20 | 11      | 9         | 17 | 40        | 0      | 1  | 4       | 4         | 0  |
| 7         |        |    | 11      | 19        | 31 | 45        | 4      |    | 4       | 15        | 8  |
| 8         |        |    | 7       | 24        | 29 | 50        | 7      |    | 11      | 24        | 13 |
| 10        | 23     | 22 | 11      | 24        | 24 | 55        | 16     |    | 9       | 21        | 24 |
| 15        | 7      | 8  | 2       | 19        | 14 | 60        | 50     |    | 21      | 19        | 31 |
| 17        | 7      |    | 5       | 19        | 10 |           |        |    |         |           |    |

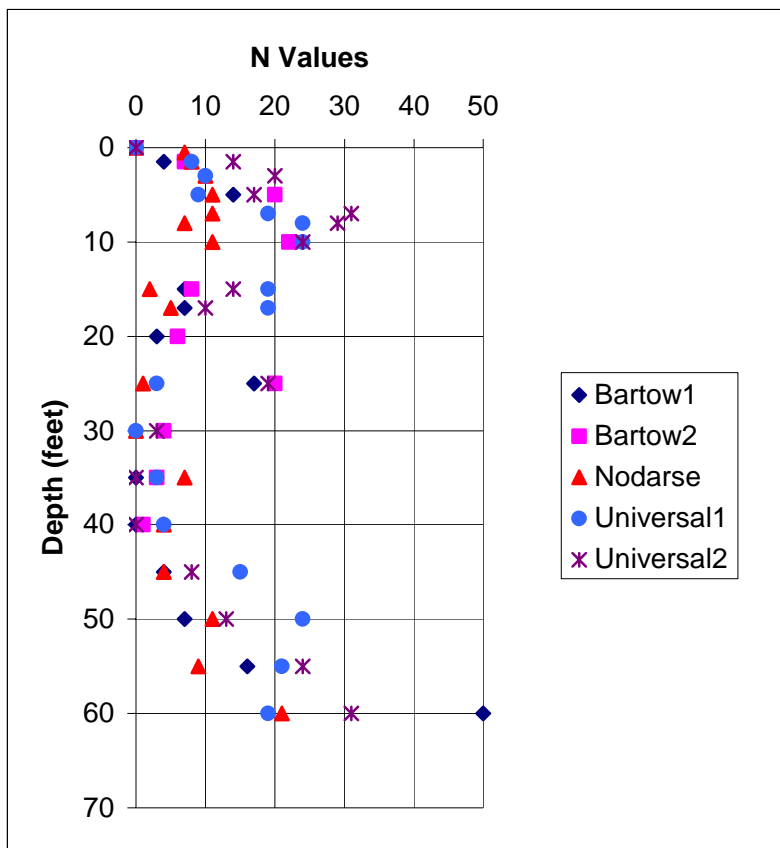

Figure 6. Summary of 5 SPT Borings at UCF Test Site

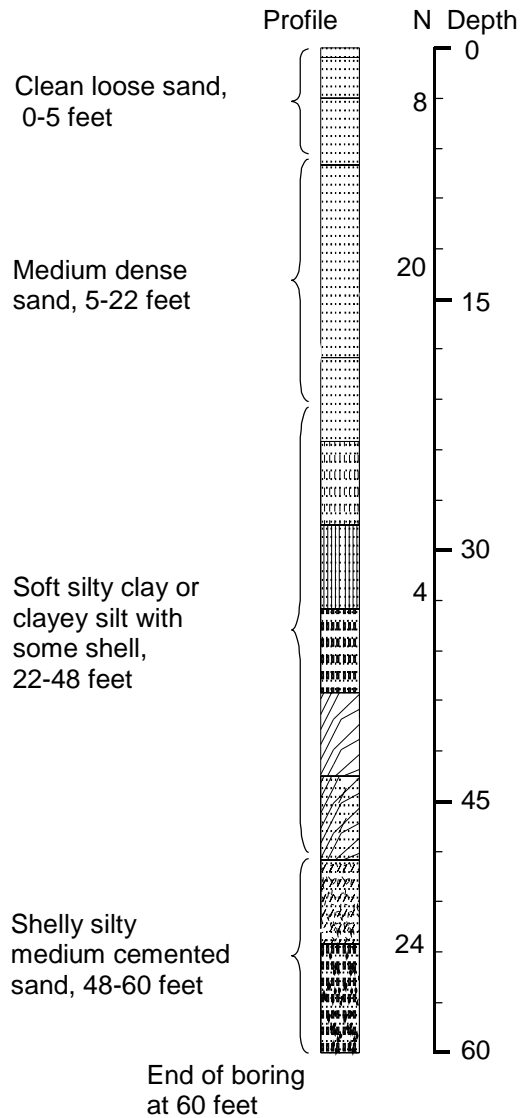

Figure 7. Generalized Site Stratigraphy from 5 SPT Tests

The comparison between the two groups, East and West, corroborate the information obtained through the SPT tests. This is the existence of a hardpan layer of sand or silty sand in the East section of the site. This layer was not found on the West area of the site. The DMT located the Hardpan layer at a depth of 10 feet.

The description of soil stratification obtained with the data reduction of the DMT test coincides with the description given by the sieve and visual classification of samples obtained from the SPT tests. General soil stratification from DMT includes:

- from 0–5 feet a Medium Sand;
- from 5–33 feet Sand to Silty Sand; and
- from 33–52 feet Silty Clay to Clayey silt.

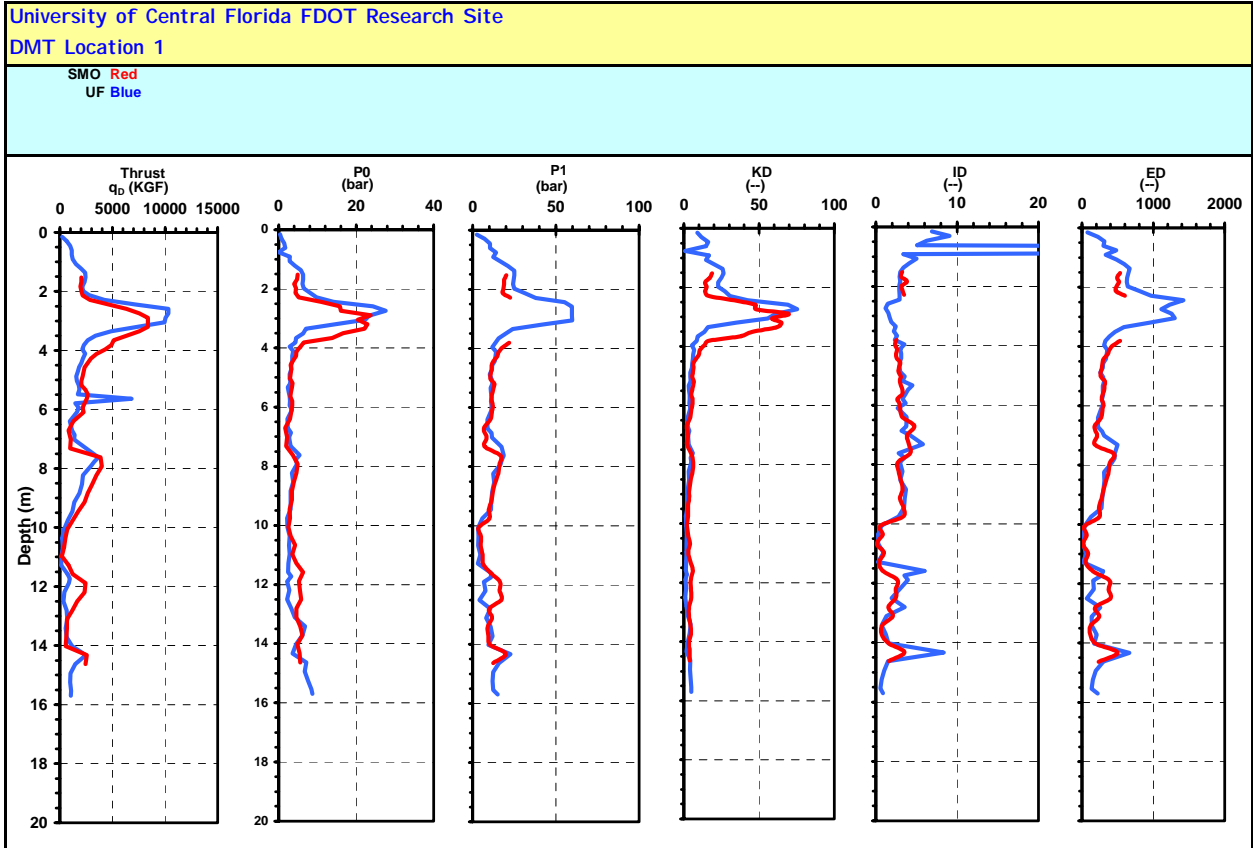

Figure 8. DMT Results for UF DMT 1 and SMO Located at East Group of SPT Tests

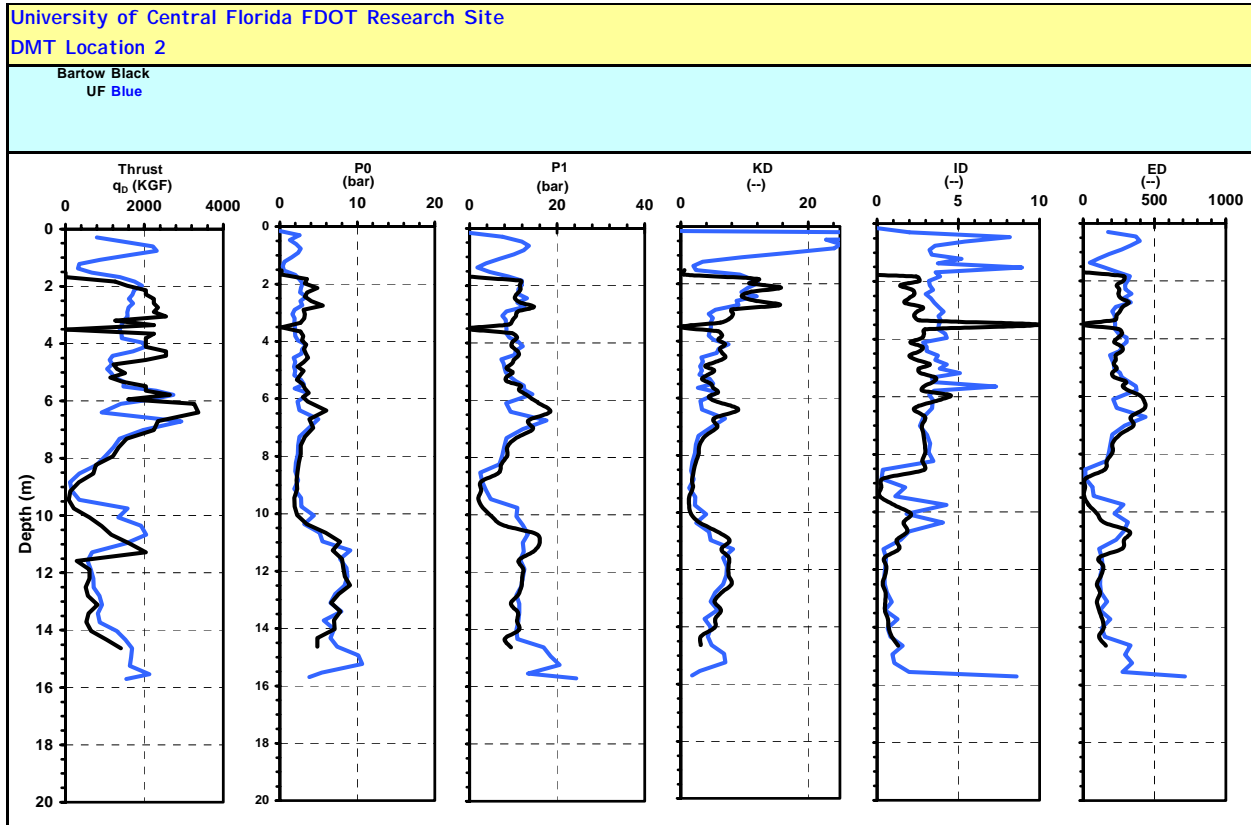

Figure 9. DMT Results for UF DMT 2 and FDOT District 1 Located at West Group of SPT Tests

## 8. STANDARD PENCEL PRESSUREMETER (PMT)

A total of two PMT tests were performed at the site, using the UF, and FDOT-SMO cone trucks. These tests were located near a Universal's SPT-2 test in order to make a future comparison of data interpretation. One purpose was to calibrate the new Pressuremeter recently acquired by SMO. The goal was to perform the tests in the field close to each other and compare results. Instructions on how to calibrate the equipment before and after the test were provided by UF on a previous meeting at UF Geotechnical Laboratory. Instruction and software to perform interpretation of collected data was also provided by UF.

### 8.1. Results

The comparison between the two PMT tests is shown in Figures 10 to 16. For all depths the UF results are much stiffer than the comparison SMO results.

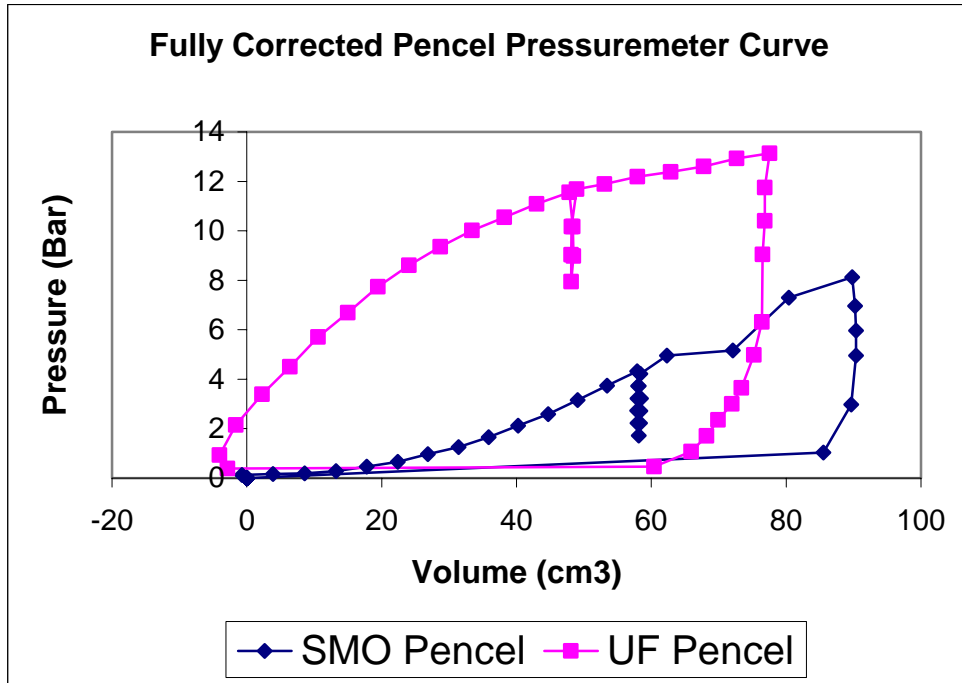

Figure 10. Comparison Graph of Data Interpretation from UF and SMO Pressuremeter at Depth 5 Feet

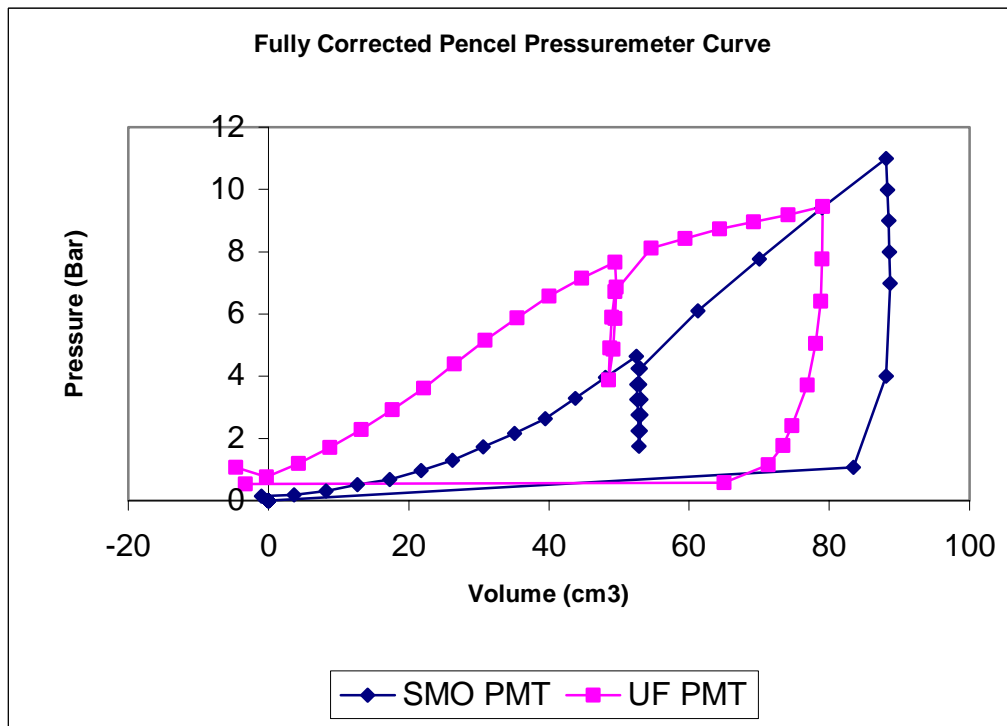

Figure 11. Comparison Graph of Data Interpretation from UF and SMO Pressuremeter at Depth 10 Feet

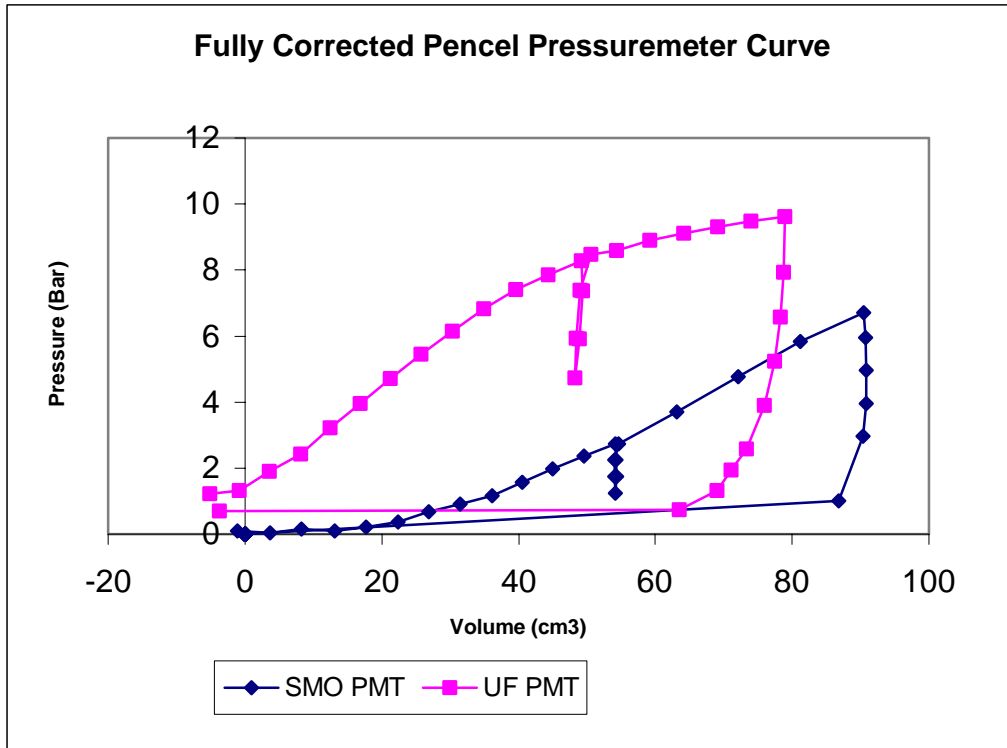

Figure 12. Comparison Graph of Data Interpretation from UF and SMO Pressuremeter at Depth 15 Feet

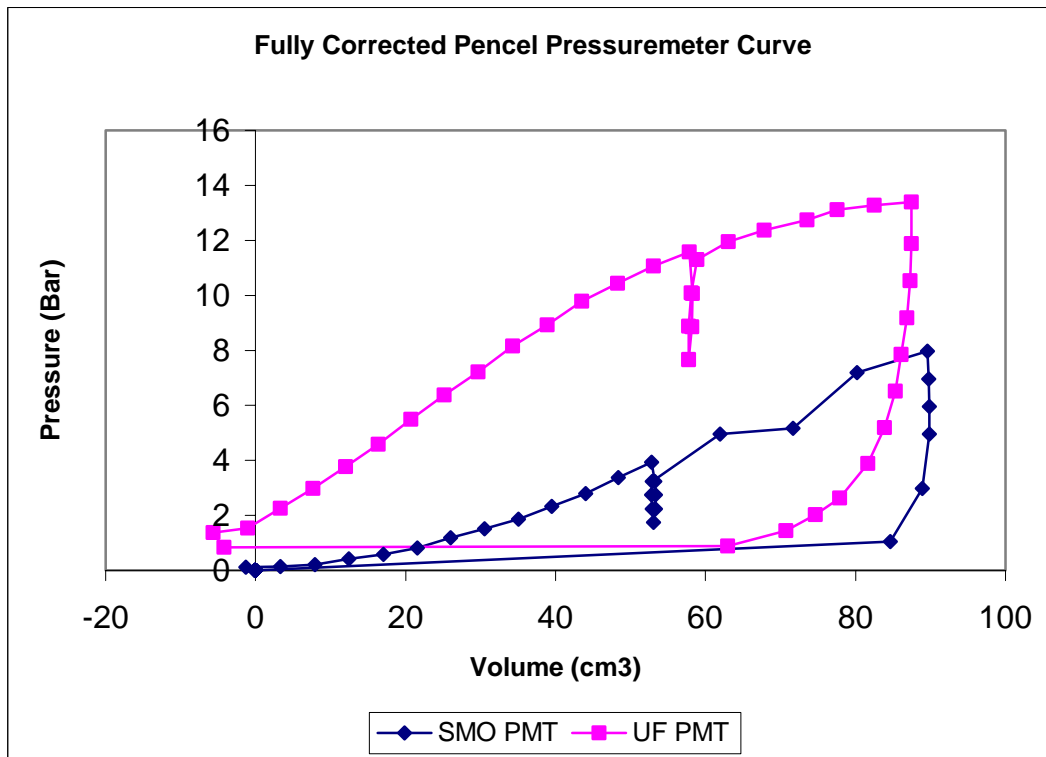

Figure 13. Comparison Graph of Data Interpretation from UF and SMO Pressuremeter at Depth 20 Feet

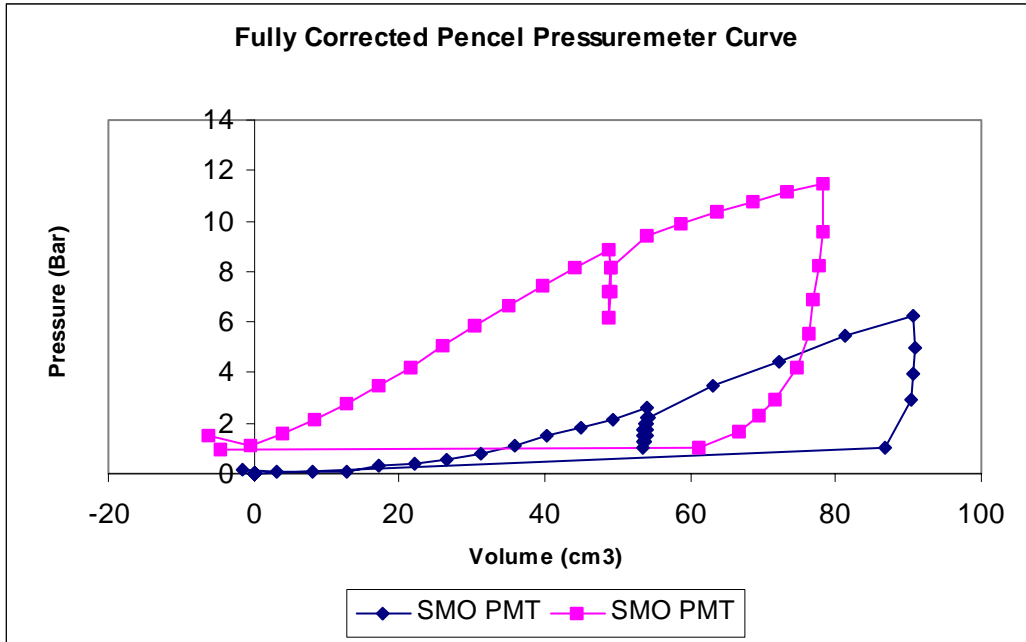

Figure 14. Comparison Graph of Data Interpretation from UF and SMO Pressuremeter at Depth 25 Feet

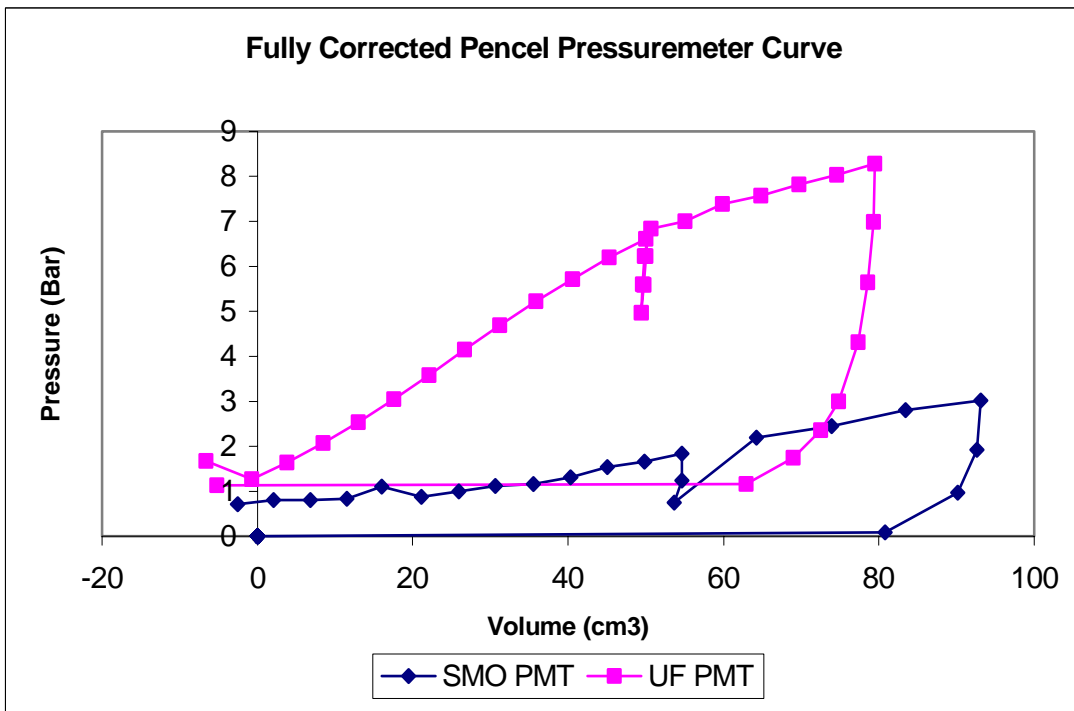

Figure 15. Comparison Graph of Data Interpretation from UF and SMO Pressuremeter at Depth 30 Feet

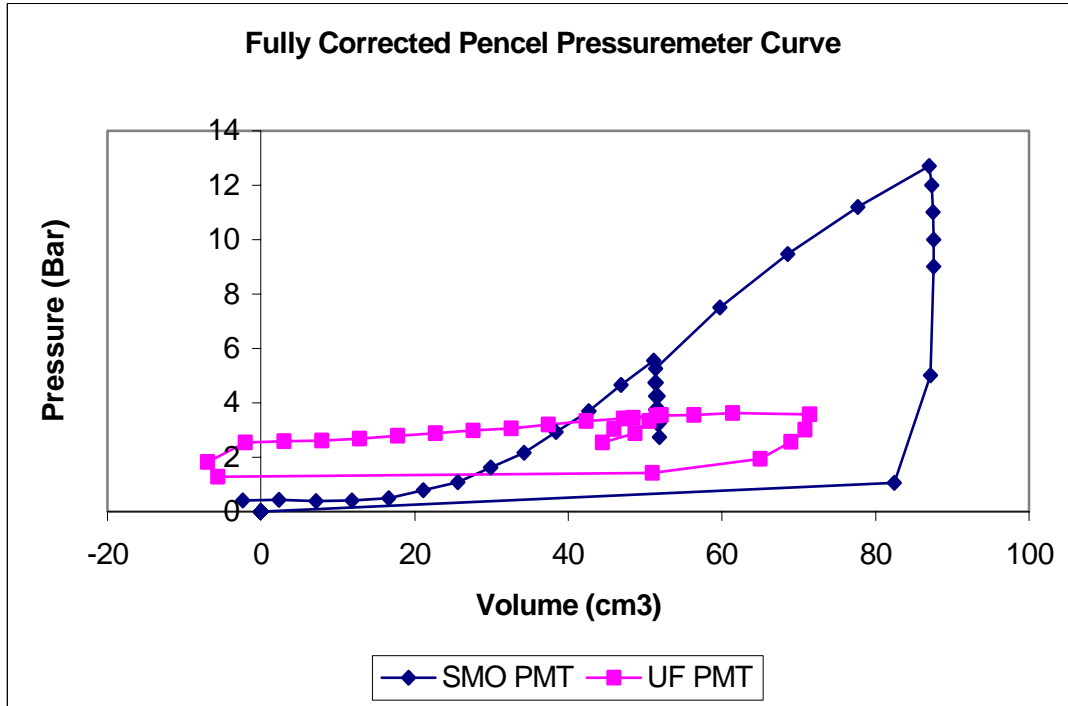

Figure 16. Comparison Graph of Data Interpretation from UF and SMO Pressuremeter at Depth 35 Feet

The information collected in the use of the SMO equipment suggest:

- More experience is required in the process of calibration, which is very tedious.
- The equipment is too new and probably need to exercise the membrane of the pressuremeter.
- Other factor that could influence on the information obtained is the fact that the UF equipment uses a slightly different tip shape.
- UF equipment uses a digital gage instead of the dial gage used by the equipment belonging to SMO during the process of reading. The digital gage helps the untrained eyes during calibration and test process.

## 9. CONE PENETRATION TEST (CPT)

A total of 14 CPT tests were performed at the site, using the UF, FDOT-SMO, and FDOT District 1 cone trucks. In addition Ardaman and Associates performed a mini-CPT test. These tests were located near a SPT test in order to make a future comparison of data interpretation. Due to the cone penetration test reliability a larger number of this type of test was performed at the site in comparison with any other test performed at the area. In addition, most of the participating companies on site have similar equipment and lesser operator error was anticipated. This condition provides a good opportunity for calibration of gear and accurate data

interpretation. In order to obtain an accurate description of the soil layers conforming the area, the CPT tests were located at the corners and center of the site.

The comparison between the participating companies at different locations of the site is shown in Figures 17 to 25. Comparison charts indicate that little or no-change is observed between them. These results confirm the soil stratigraphy results of the area obtained with the rest of the equipment (DMT, PMT and SPT). This is:

- The data obtained with the cone confirm the existence of a hardpan layer located between 8 and 12 feet on the East region of the site.
- The little change of values for tip resistance, friction ratio, etc shown in the charts is an indication of a relative uniformity on the site.
- The transition from a “Soft Material” to a “Hard Material” in the upper layer of sand and silty sand is easily appreciated (see cross sections in Figures 21, 22 and 23).
- The existence of a well-defined layer of silty clay or clayey silt from depth 33 to 50 feet in the entire area was confirmed by the test.

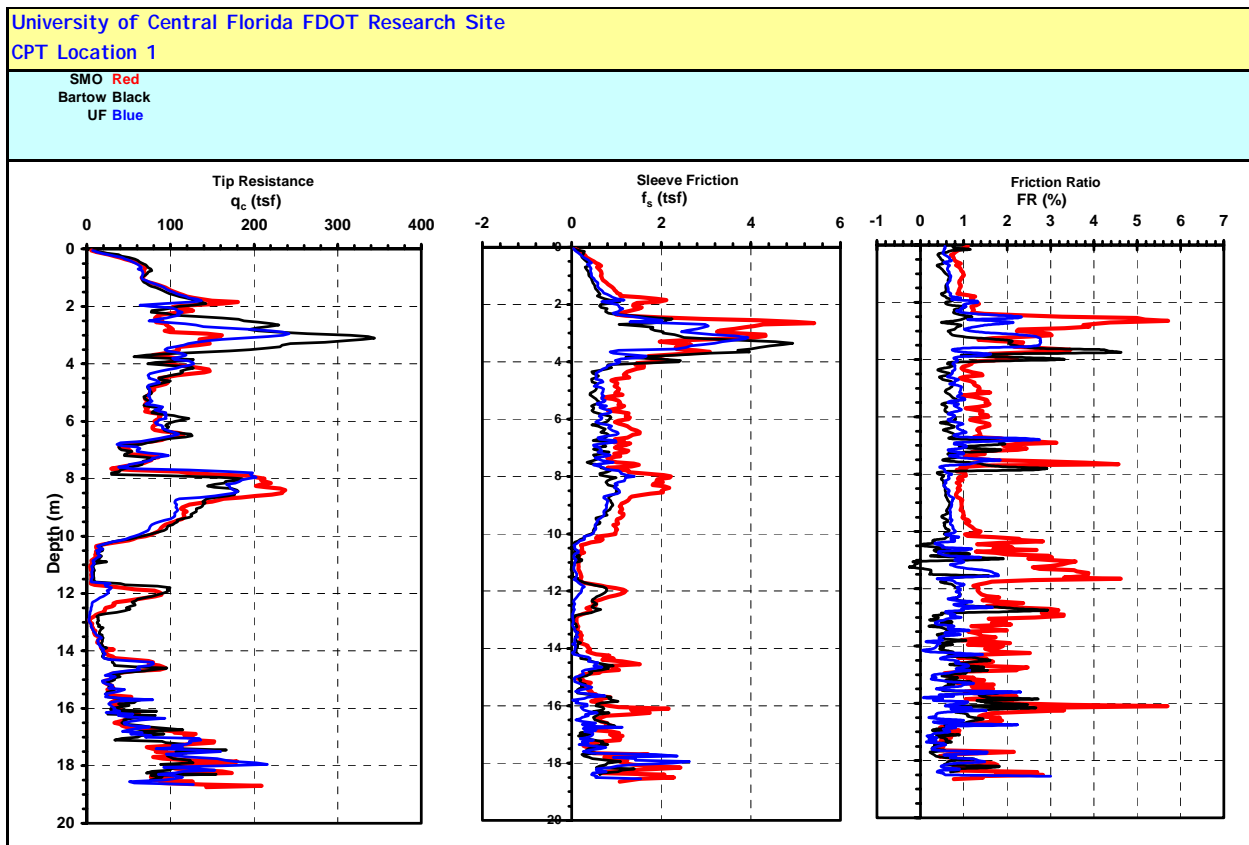

Figure 17. CPT Soundings at NE Corner Location 1

SMO Red  
Bartow Black  
UF Blue  
Ardaman Green

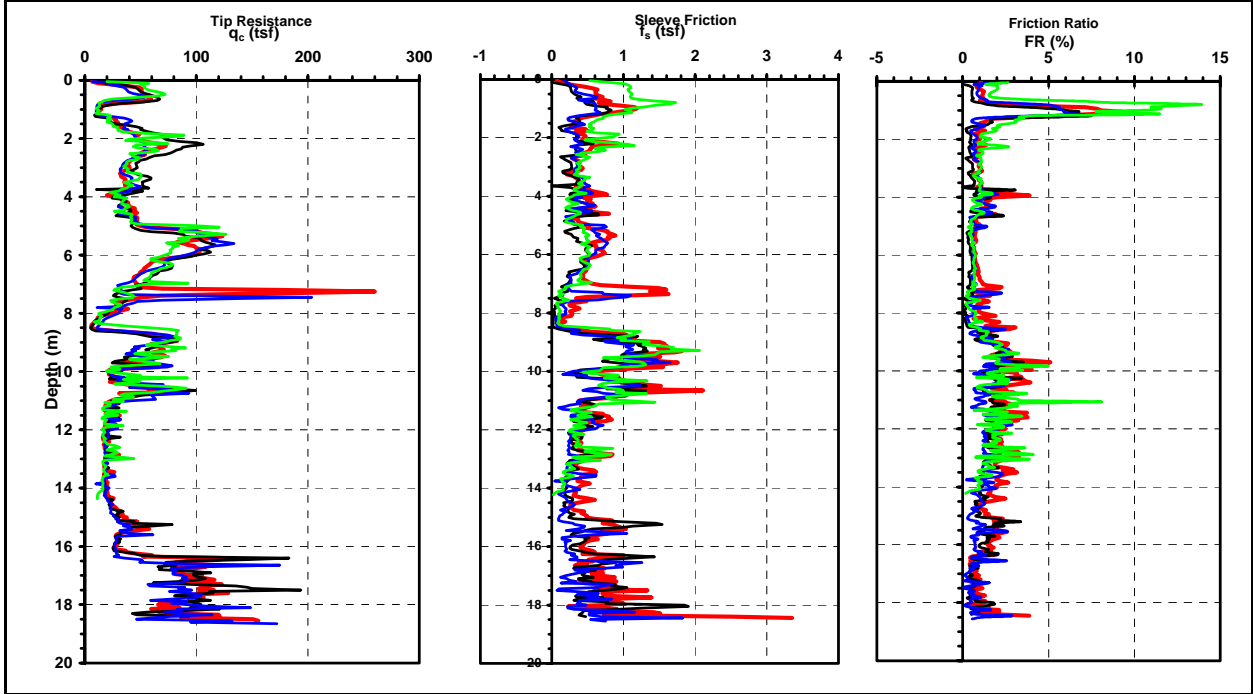

Figure 18. CPT Soundings at NW Corner Location 2

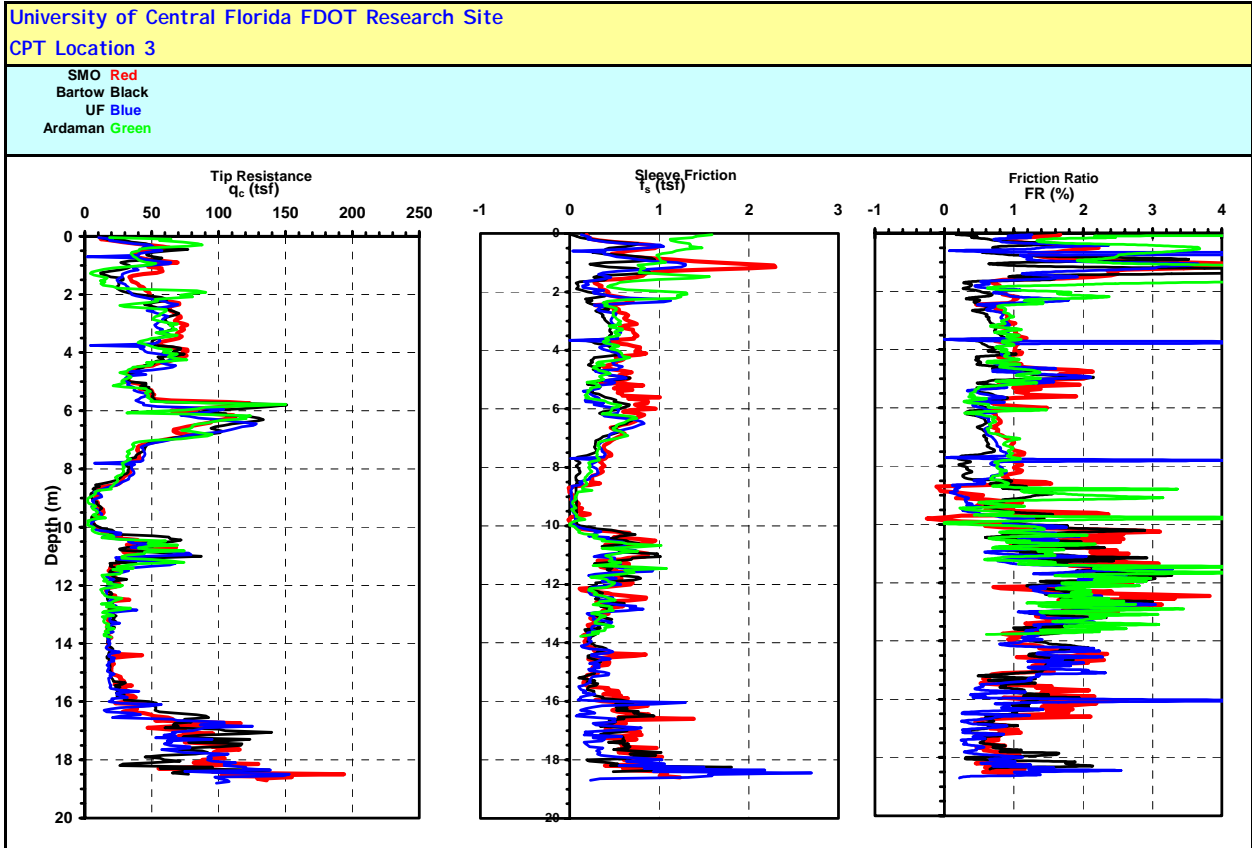

Figure 19. CPT Soundings at SW Corner Location 3

University of Central Florida FDOT Research Site  
CPT Location 4

SMO Red  
Bartow Black  
UF Blue

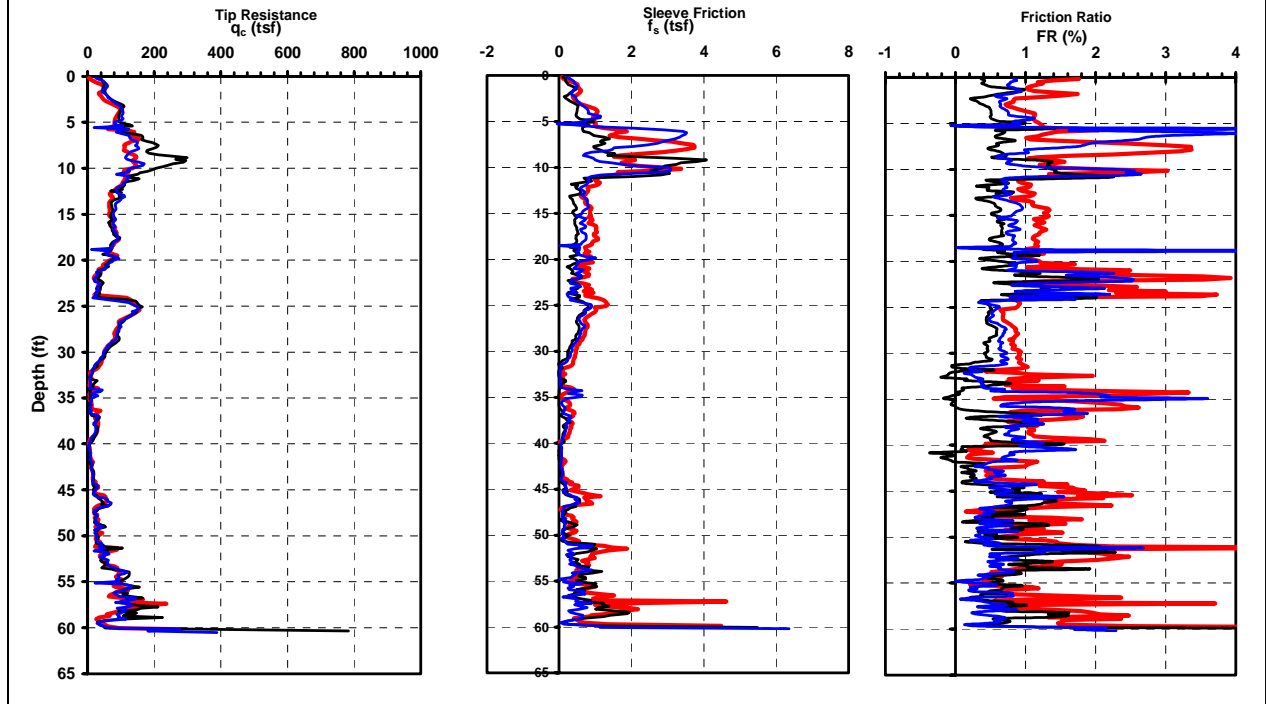

Figure 20. CPT Soundings at SW Corner Location 4

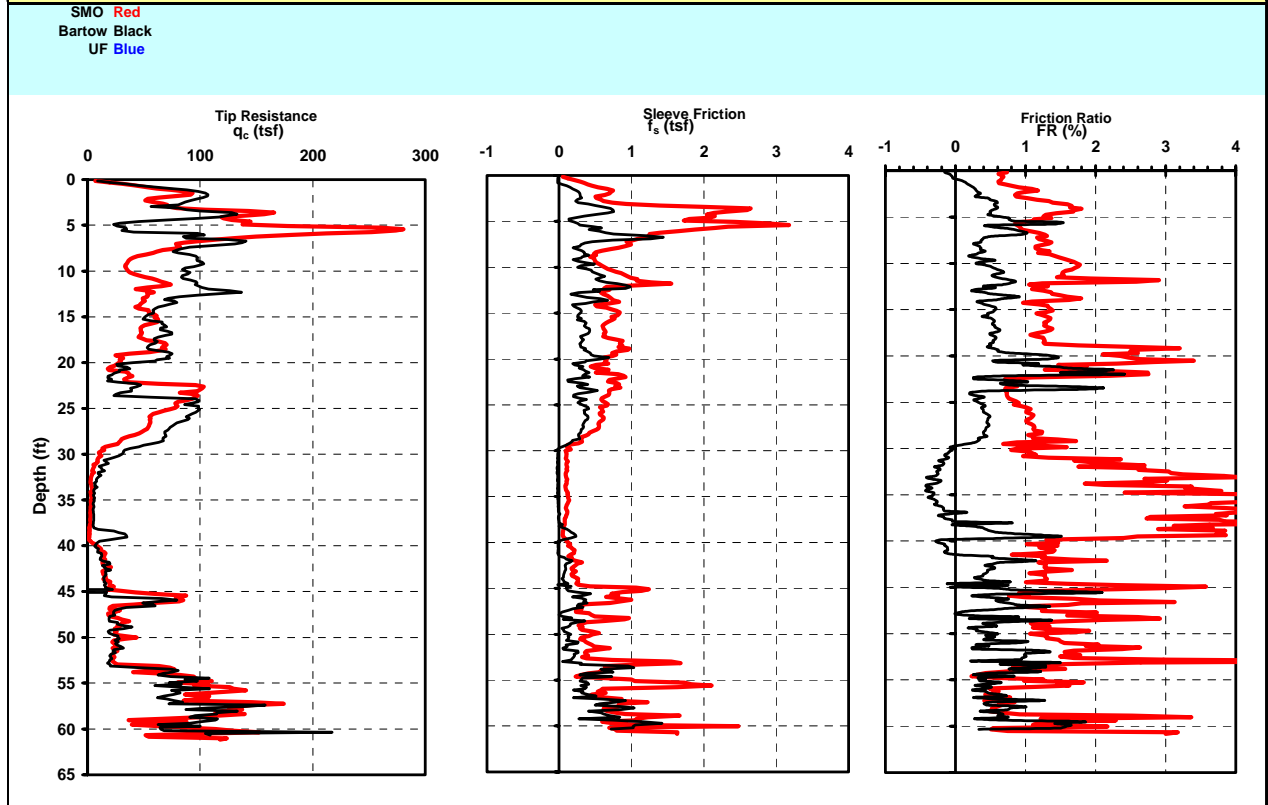

Figure 21. CPT Soundings at Center Location 5

University of Central Florida FDOT Research Site  
CPT Location 6

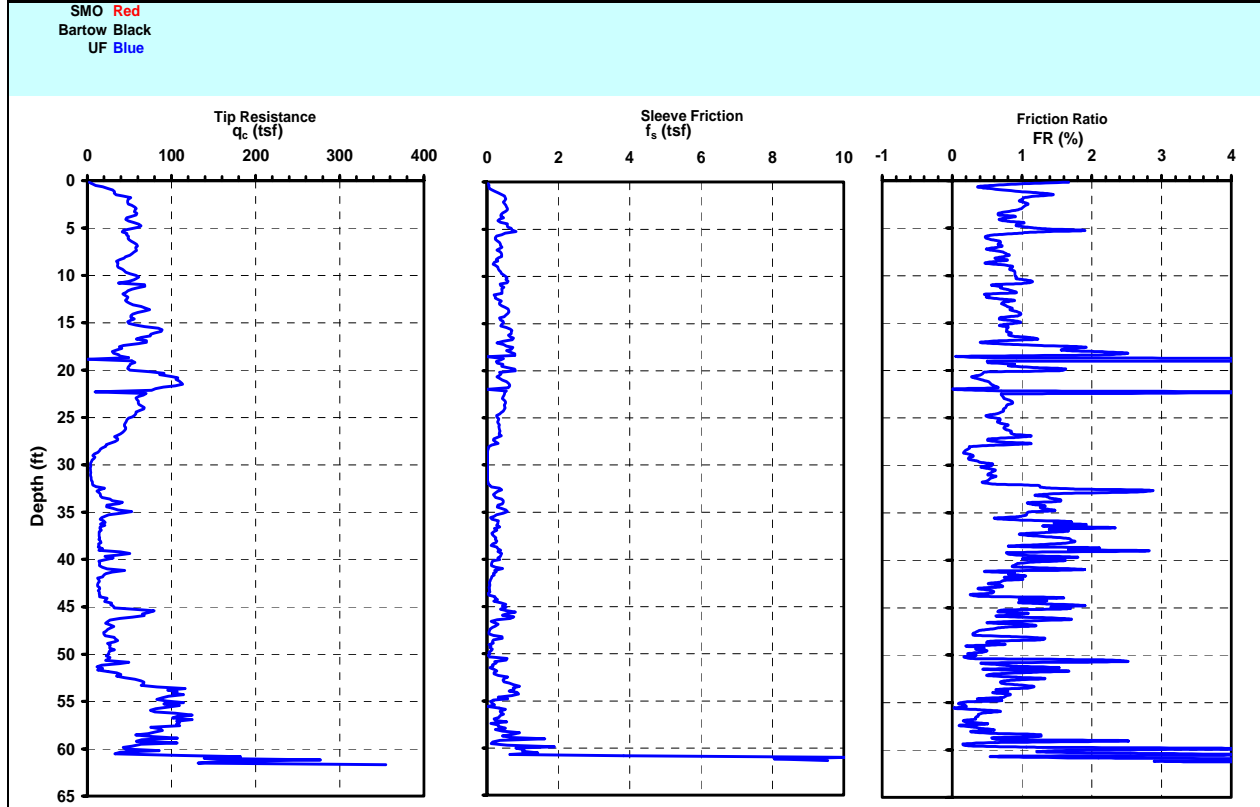

Figure 22. CPT Soundings at South Location 6 (South Center)

Cross section CPT 3-6-4

SMO Red  
Bartow Black  
UF Blue  
Ardaman Green

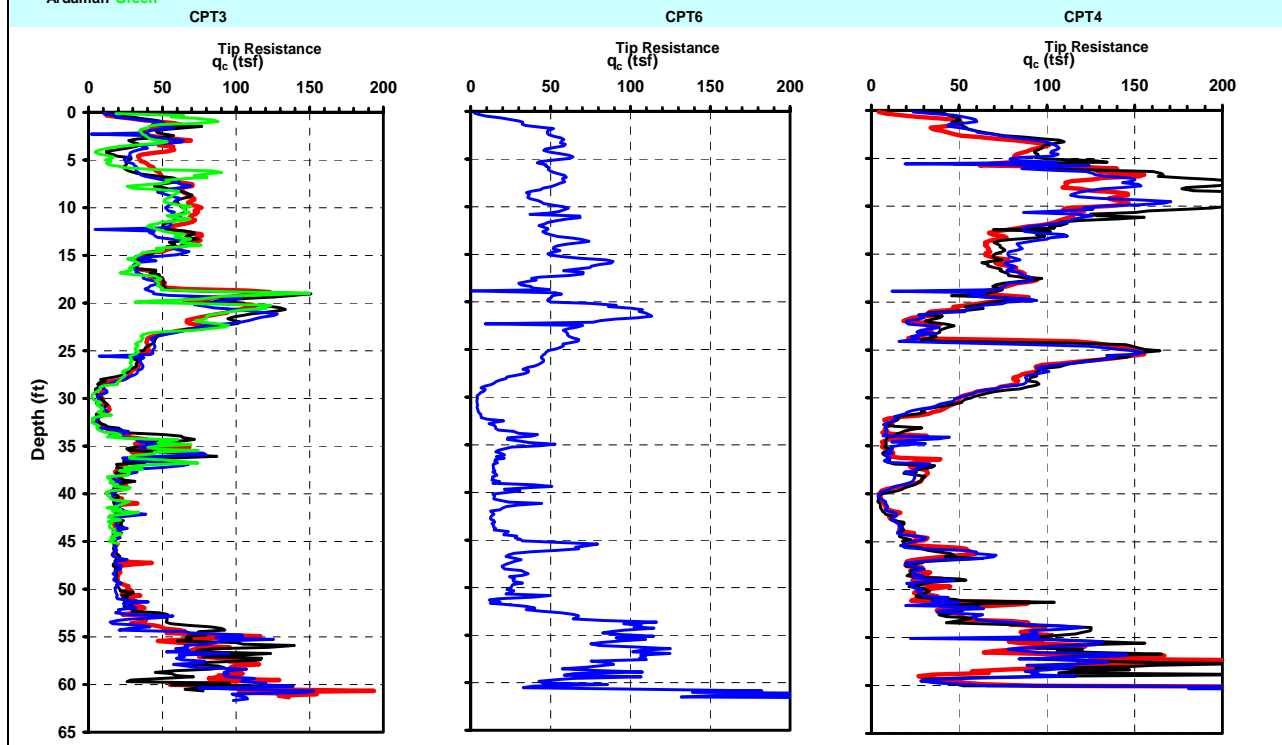

Figure 23. CPT Soundings Cross Section Show Increasing Tip Resistance Along SW to SE Portion of the Site

Cross section CPT 2-5-4

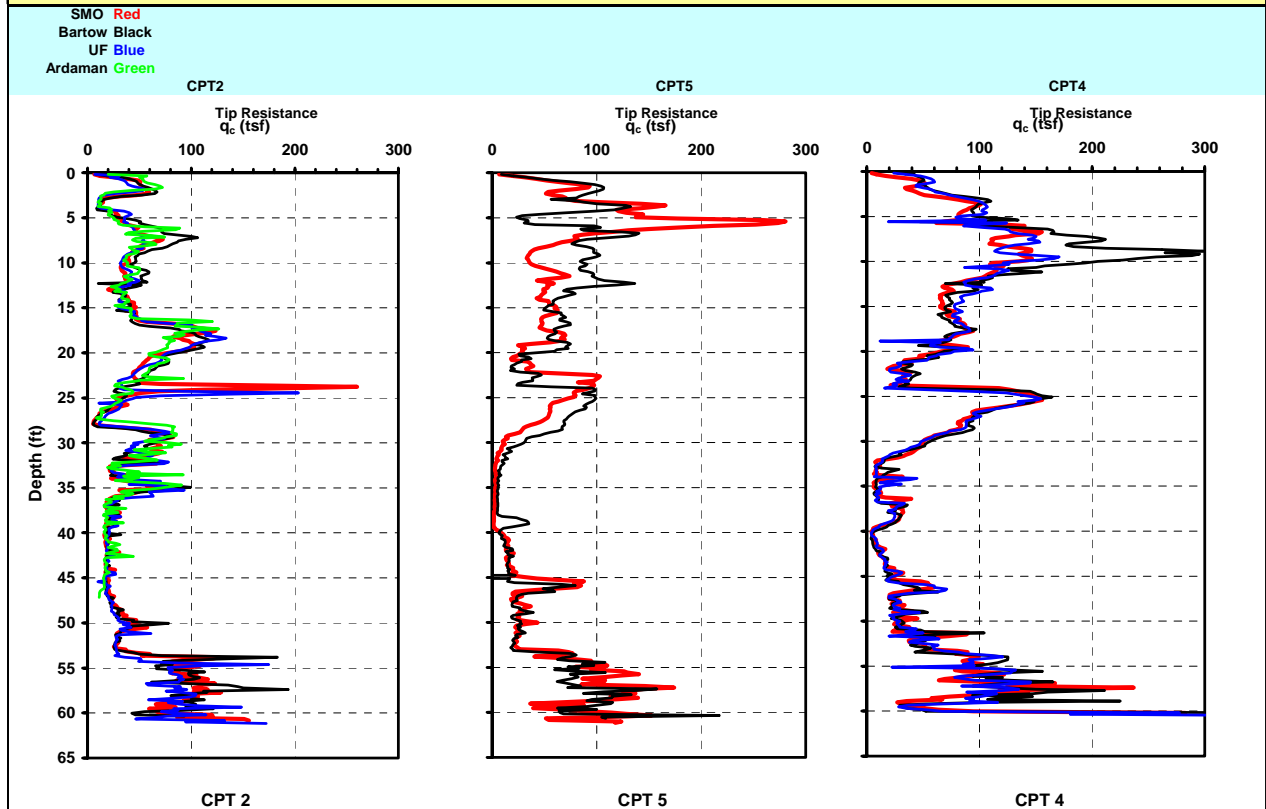

Figure 24. CPT Soundings Show Increasing Tip Resistance Along NW to SE Cross Section of the Site

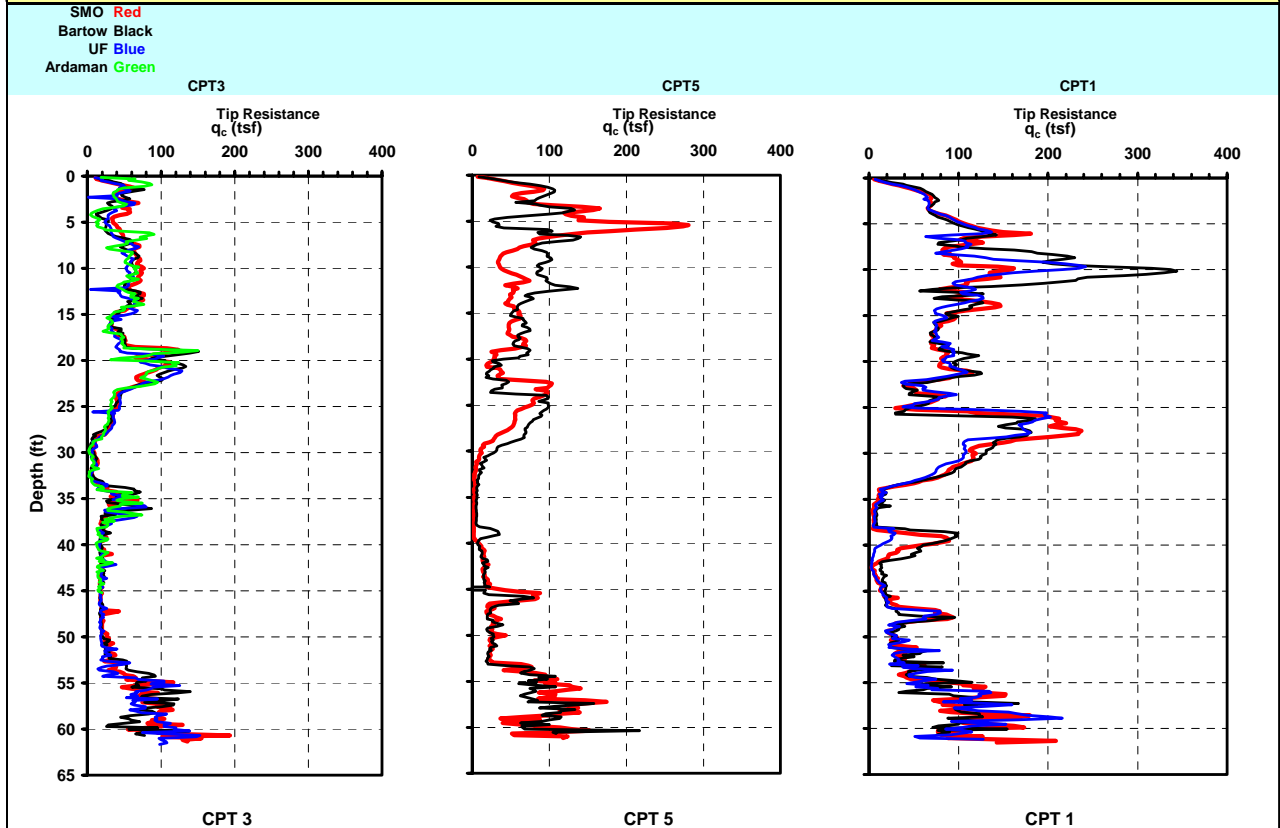

Figure 25. CPT Soundings Show Increasing Tip Resistance Along SW to NE Cross Section of the Site

## 10. SOIL PROFILE

### 10.1. General Soil Description

The soils at the UCF-FDOT Site selected for this project are predominantly sand. Based upon the insitu soil testing performed at the site the following conclusions were made.

In general, the stratigraphy of the site is typically sand to silty sand overlying clayey soil that is more prominent on the west side of the site (CPT groups 2, 3 and 5). The presence of which was verified by the SPT and CPT borings.

An extremely stiff hardpan lens was found in the vicinity of the central group of CPT tests (SMO CPT 5 and Bartow CPT5) and UF DMT1. Truck refusal was encountered by the CPT tests in that area, and a total thrust of 11.5 tons was reached with the DMT for penetration.

The general SPT profile is as follows:

|           |  |
|-----------|--|
| 0 – 5 ft. | Clean loose sands at surface, blow counts 8-10 |
| 5 – 22    | Med dense sands, $N \approx 20$                |
| 22 – 48   | Soft clay or silt, $N \approx 4$               |
| 48 – 60   | Shelly silty sand, $N \approx 24$              |
| 60 feet   | End of Boring.                                 |

### 10.2. 3D Soil Characterization

With the purpose of having a better graphical perspective of the soil stratigraphy, a 3D “view” of the site was performed using of the Software GMS (Groundwater Modeling System). The goal was to delineate the change of soil properties between “different” areas of the site. In addition, if successful FDOT may wish to consider using this software for various projects.

The cone penetration test data was very useful in the design of a 3D view of the soil stratification of the site. The GMS software, allows one to translate information collected directly from the cone truck (as tip resistance, friction ratio, soil stratification, etc) into visual information in shape of borings logs on a 3D view. This software is able to create several nets of triangular shape that interconnect information from different borings. Areas not investigated with the cone truck are statistically analyzed and information added by the software. As a final result, the information is given as a 3D solid shape. The program also allows one to obtain cross sections from the new 3D solid model created. Figures 26 to 32 present these results.

In Figure 26, the different colors at each boring represent the stratification. As is usual in this type of work the information obtained through the cone truck is extremely detailed, for this reason the GMS software allows the user to edit the information of each boring, in order to use only the essential data.

Figures 27 and 28 show differing three-dimensional views of the site. Figures 29 through 31 show various cross sections of the site.

Figures 32 and 33 illustrate general and more specific characterizations of change in tip resistance, respectively. In Figure 32, each boring reflects the change of tip resistance based on a palette of different color. The differences between the borings are barely noticeable due to the nature of the soil at the site. Change of  $Q_c$  software values along the site is not significant. The greens strips located at the top of East borings represents position of the "hardpan" layer. In Figure 33, each boring reflects the change of tip resistance based on a palette of different color vs depth. The differences between the borings are more obvious, based on the color tip resistance. The scale on the NE corner reaches the 350 tsf at depth 10 feet where the "hardpan" layer is located vs. a 100 tsf reached by the borings at the SW corner at same depth. The goal for future work will be to translate this information (tip resistance, sleeve friction, friction ratio, etc.) and use it to draw profiles of soil properties similar to the ones shown in Figures 26 through 28. This will help to have a better description of soil properties.

Figures 34 through 39 illustrate successive overhead views of horizontal cross-sections at depths of 5, 15, 30, 45, and 50 ft. On Figures 34 and 35 line A-A delineates the separation between the "hard" NE corner and "soft" SW corner.

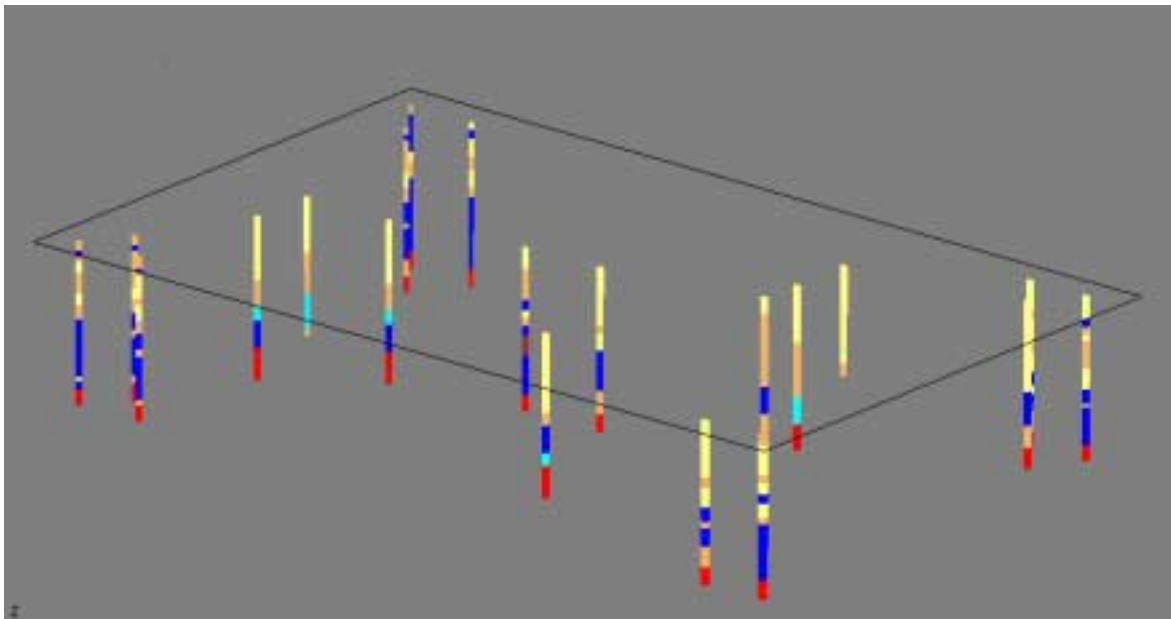
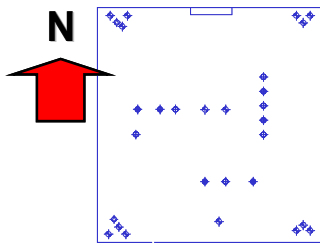
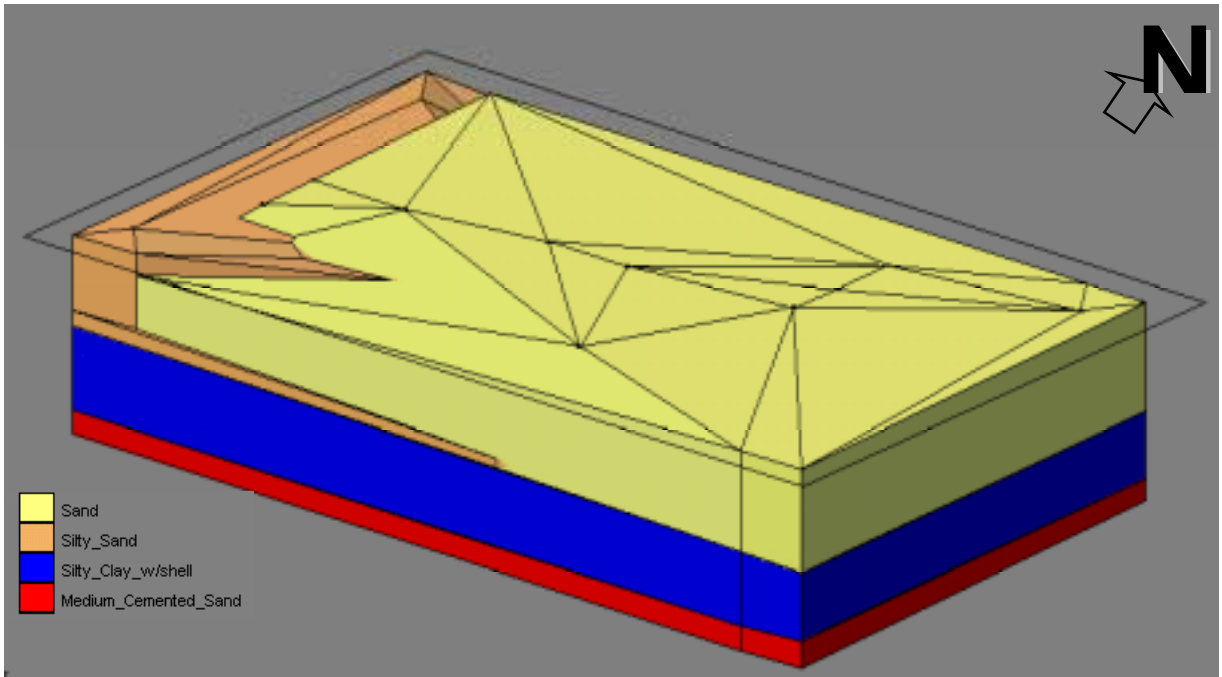
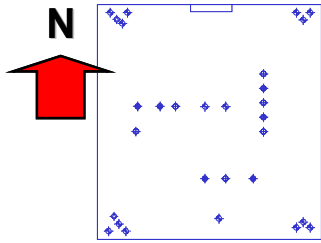
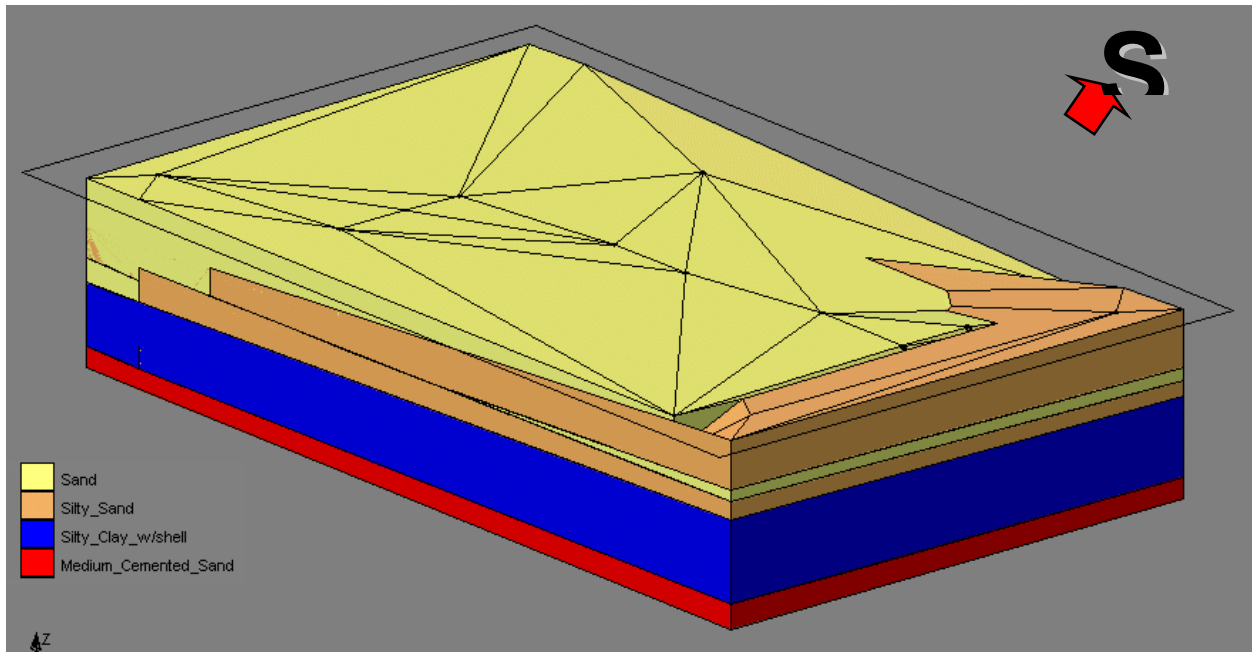
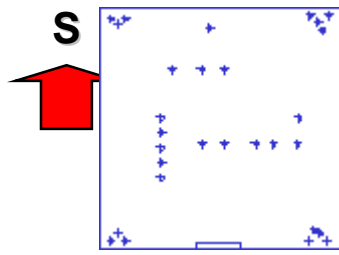

Figure 26. Relative Location of the CPT, SPT and DMT Borings Performed at the Site



Note: The yellow layer of sand represents approximately the area where the “hardpan” layer is located.

Figure 27. 3D View of the Site Looking North from the SE Corner



Note: The brown layer of Silty Sand represents approximately the area where the “Soft” layer is located.

Figure 28. 3D View of the Site Looking South from the NW Corner

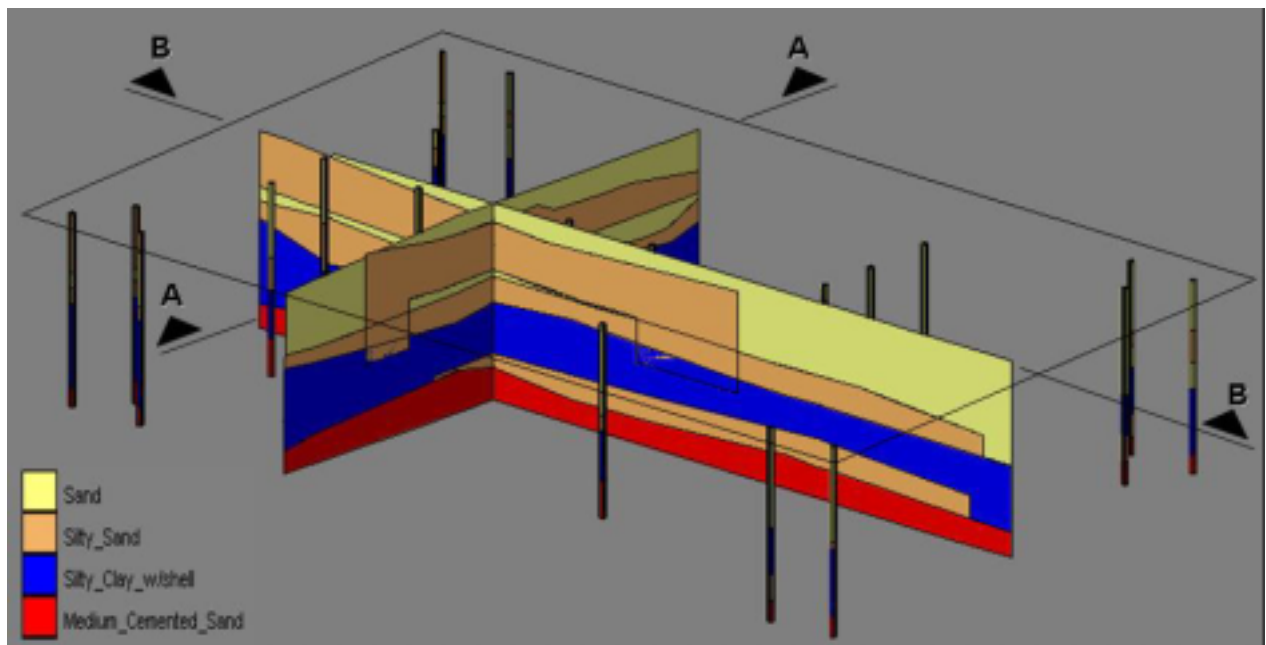
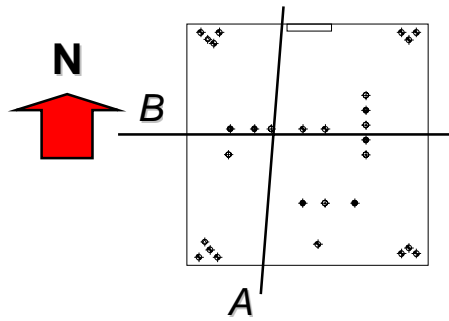

Note: Cross Section A is located on the border between “hard” and “soft” layer.  
 Cross Section B shows the extension of a third layer of silty sand not seen on the general 3D view.

Figure 29. Two Cross Sections of the Site (A and B)

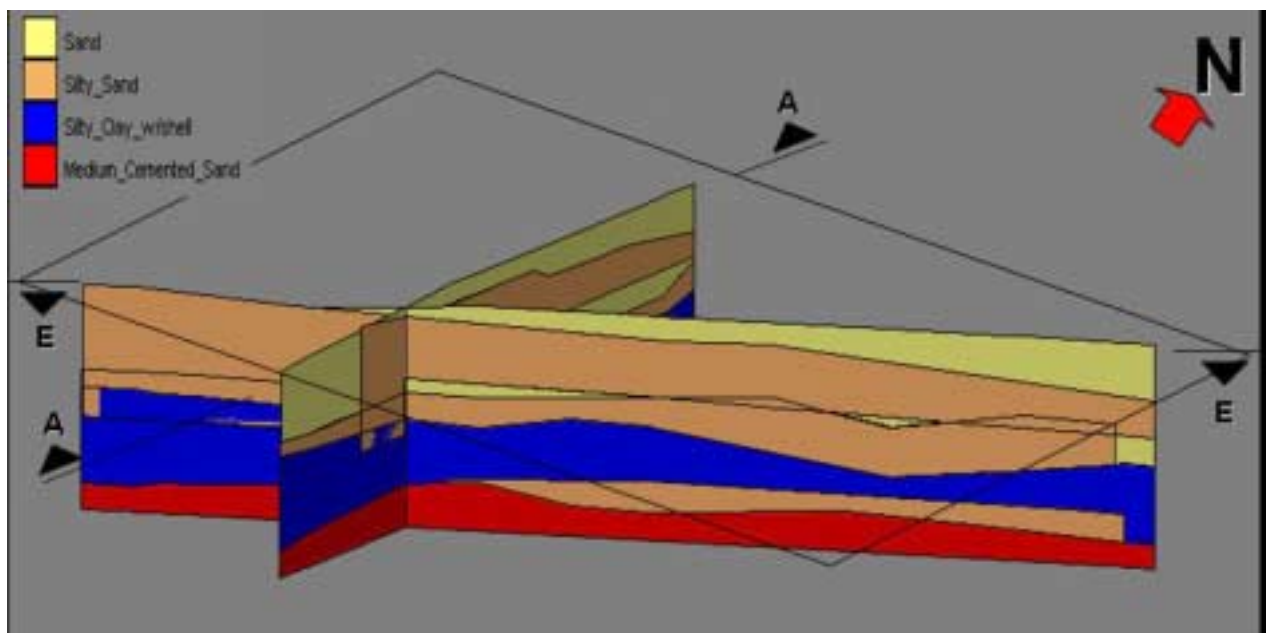
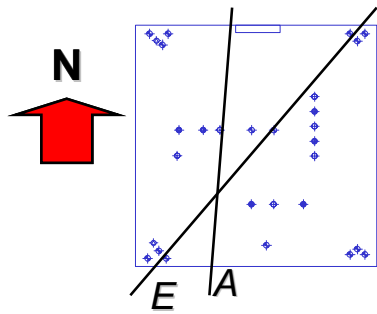

Note: Cross Section A is located on the border between “hard” and “soft” layer.  
 Cross Section E shows the change of soil type from silty sand to sand on the upper layer (this cross section is located between the “hard” SW corner and “soft” NE corner).

Figure 30. Two Cross Sections of the Site (A and E)

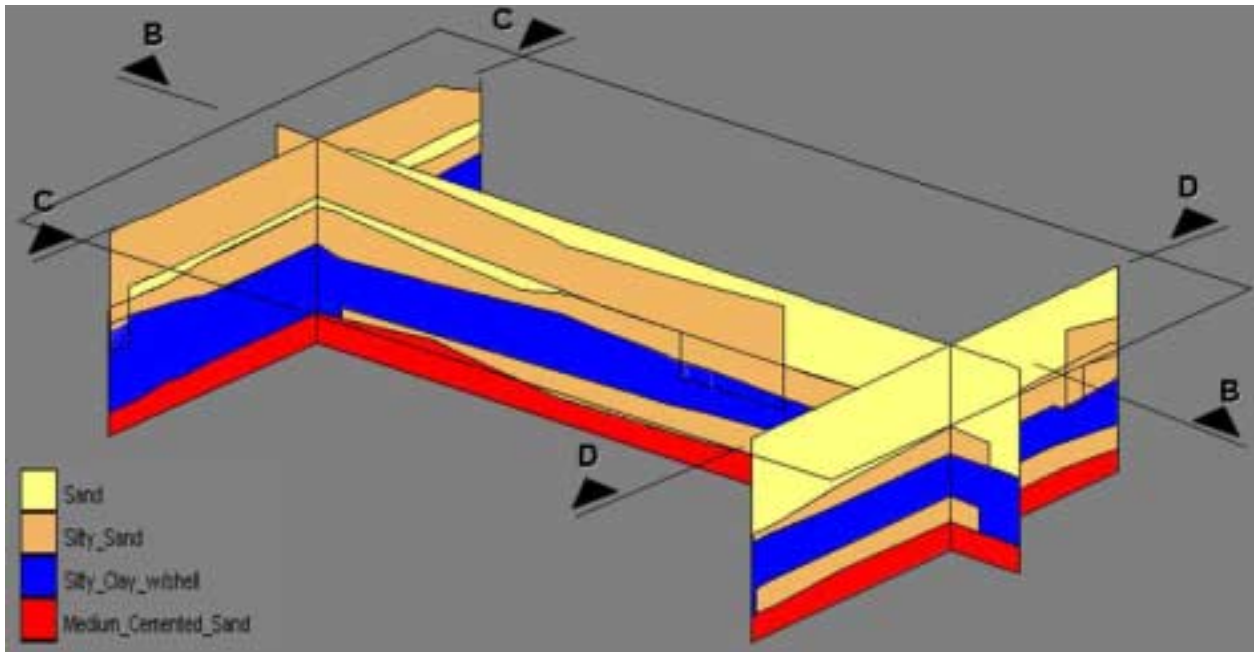
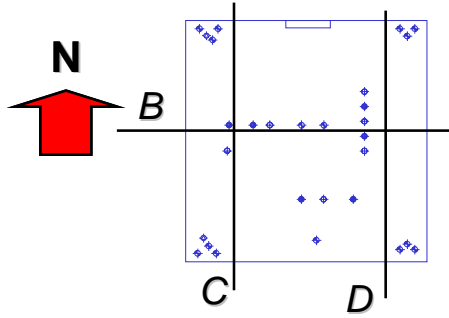

Note: Cross Section C is characterizing the “soft” area to the West.  
 Cross Section D is characterizing the “hard” East. This is a typical example of the use of the software that illustrates the use of the software when designing piles. The information shown provides enough information to determine the extension of a soft layer sensitive to scour.

Figure 31. Three Cross-Sections of the Site (B, C and D)

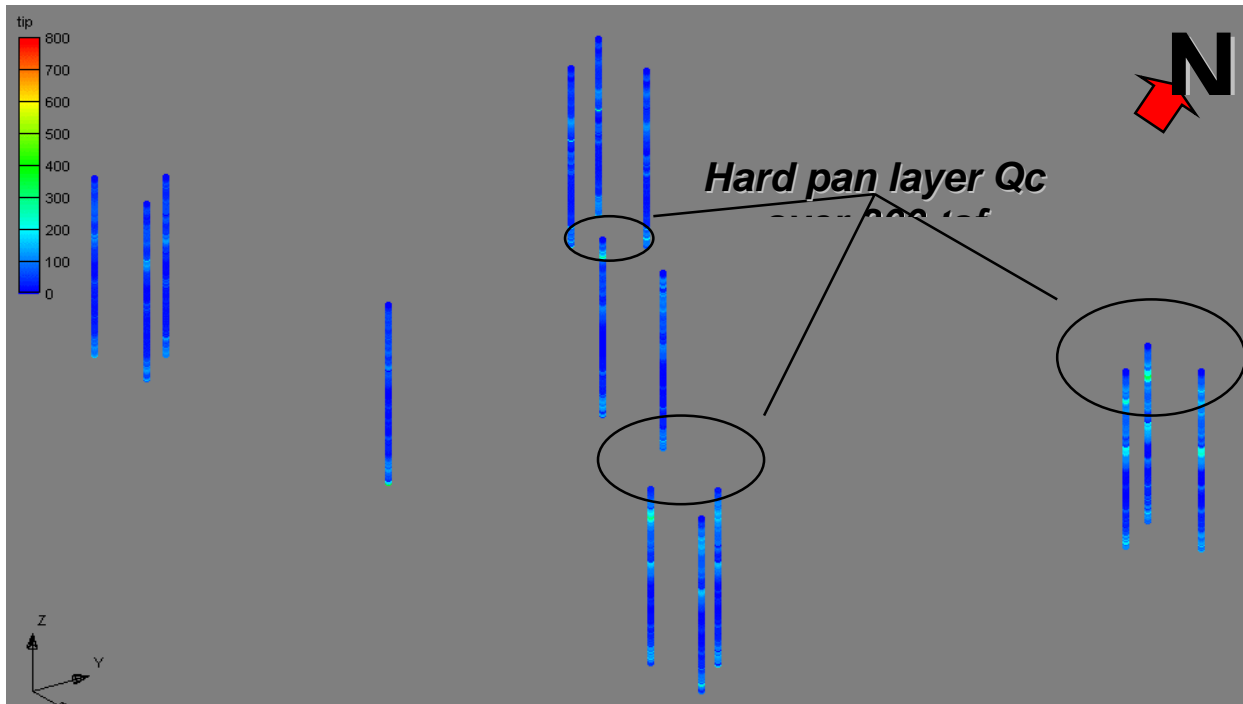
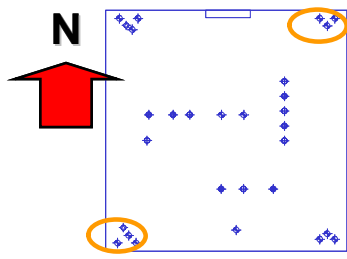

Figure 32. General Tip Resistance Characterization of the Site

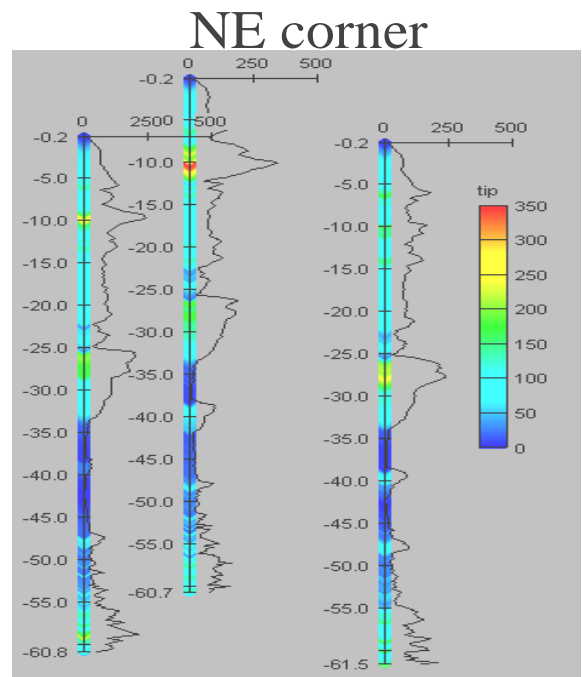
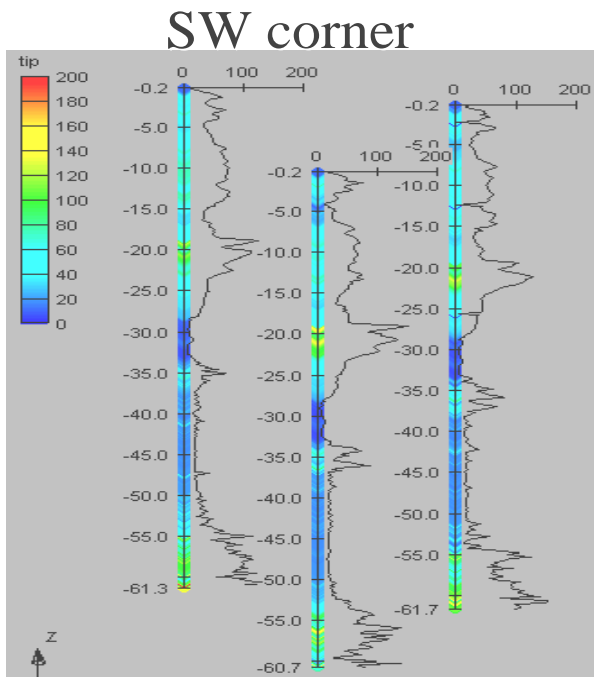
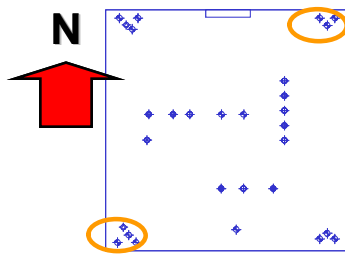
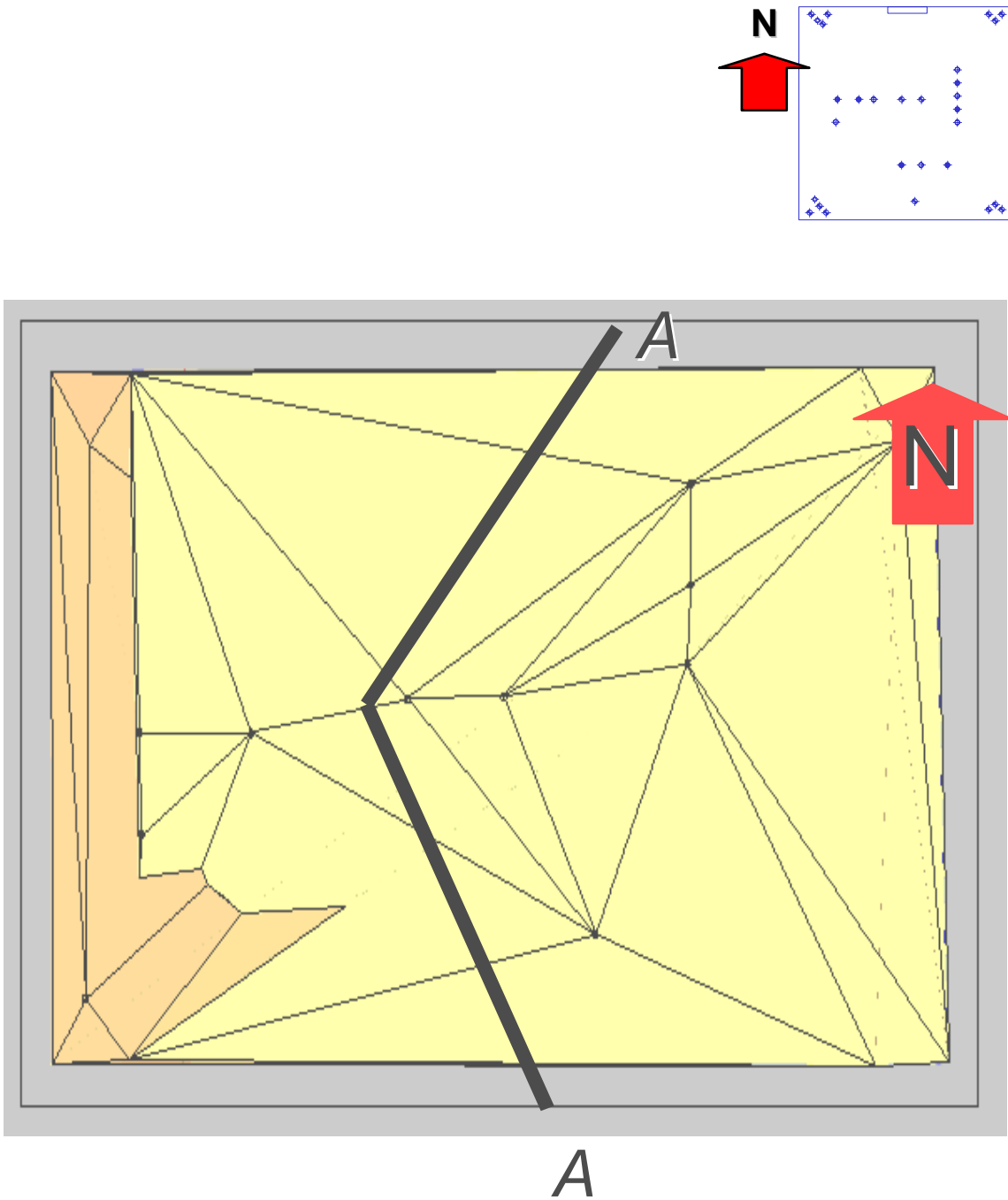
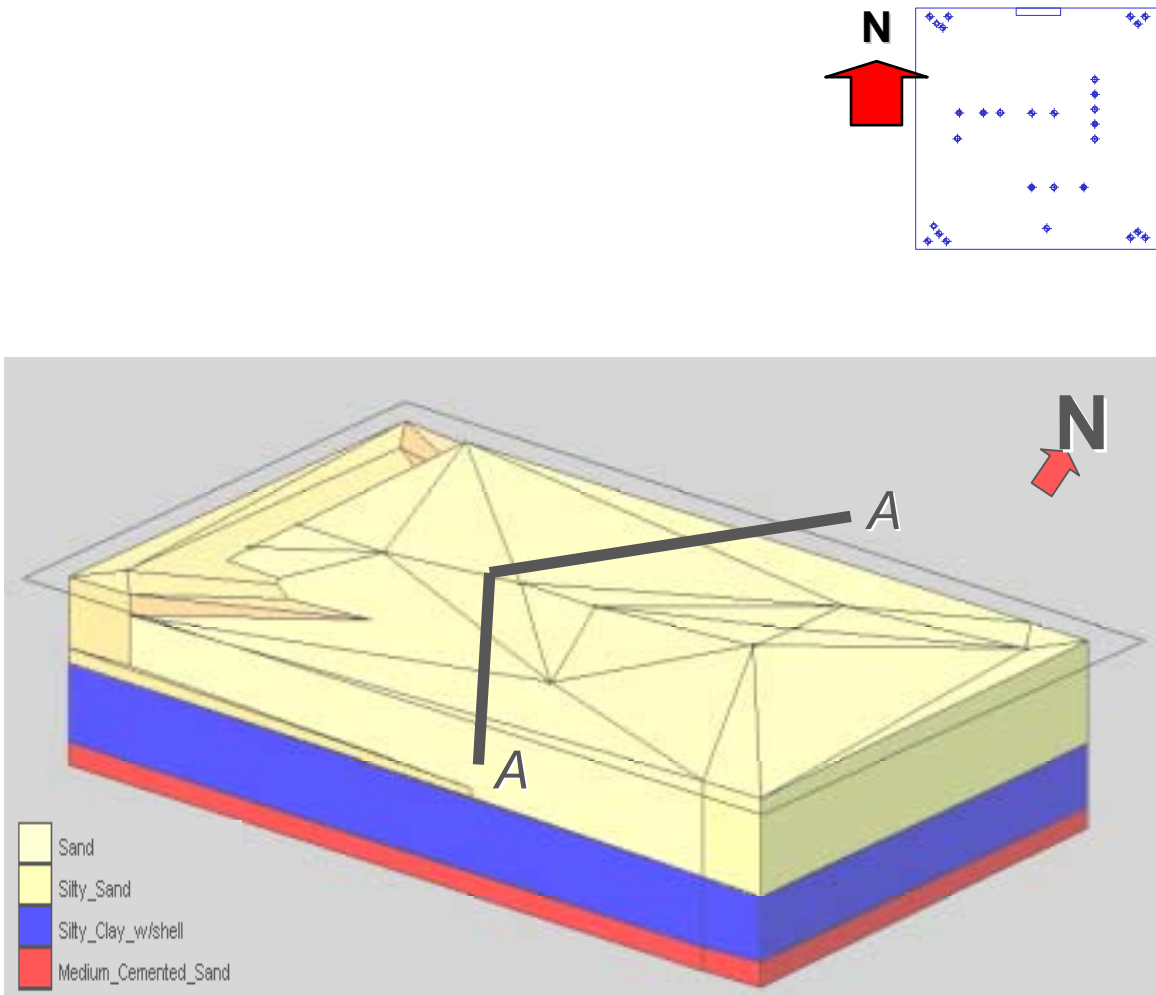

Figure 33. A Closer Look at the Change on Tip Resistance Between the “Hard” NE Corner and “Soft” SW Corner



Cross section A-A delineates the border line between “soft” SW corner and “hard” NE corner. Figure shows horizontal planar view at elevation 5 ft. Hard pan is located at depths 5 to 10 feet.

Figure 34 Overhead view at depth of 5 ft.



Vertical view looking from SE corner towards NW. Cross section A-A delineates the border line between “soft” SE corner and “hard” NW corner. Hard pan is located at depths 5 to 10 feet.

Figure 35 Overhead view at depth of 5 ft. from SE corner

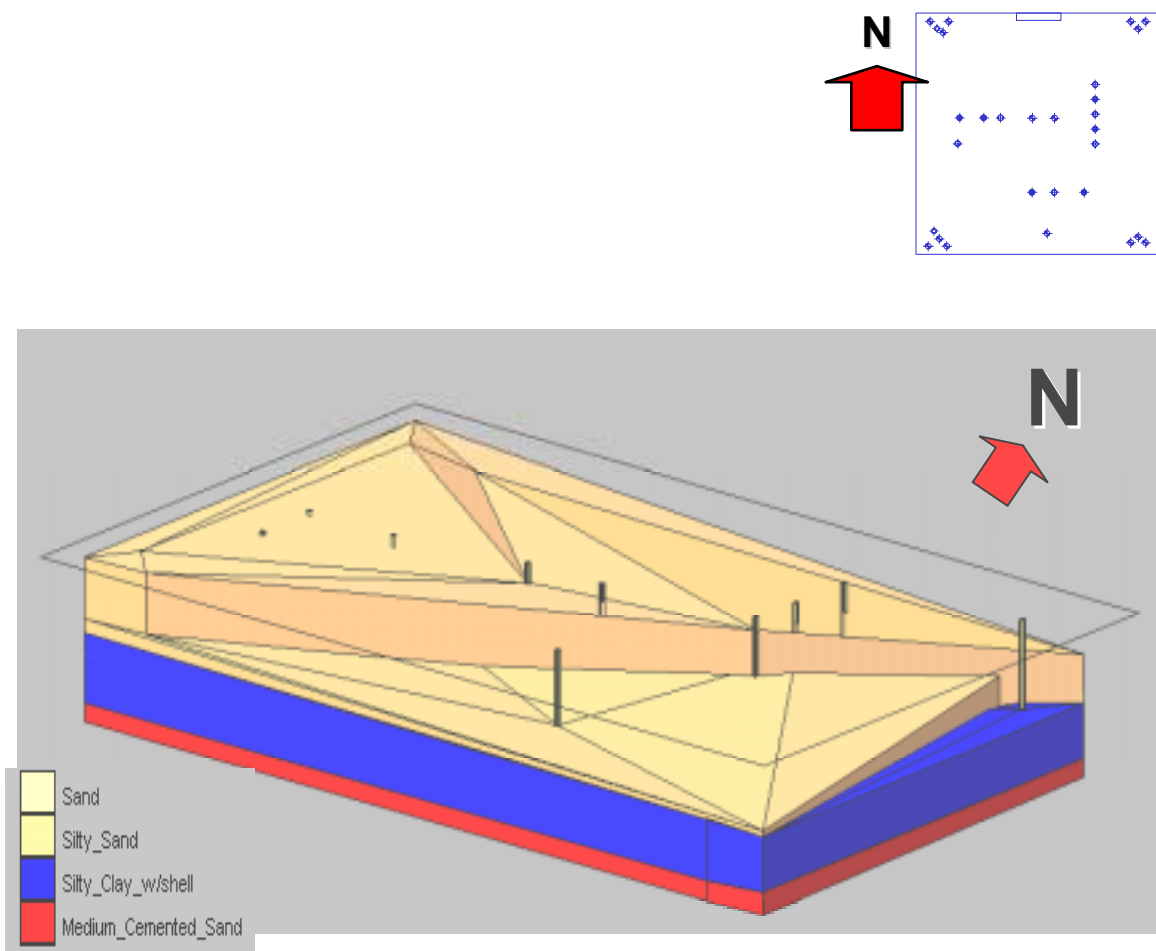

SE corner view at depth of 15 feet. The overlying hardpan and sand layers have been removed.

Figure 36 Overhead view at depth of 15 ft.

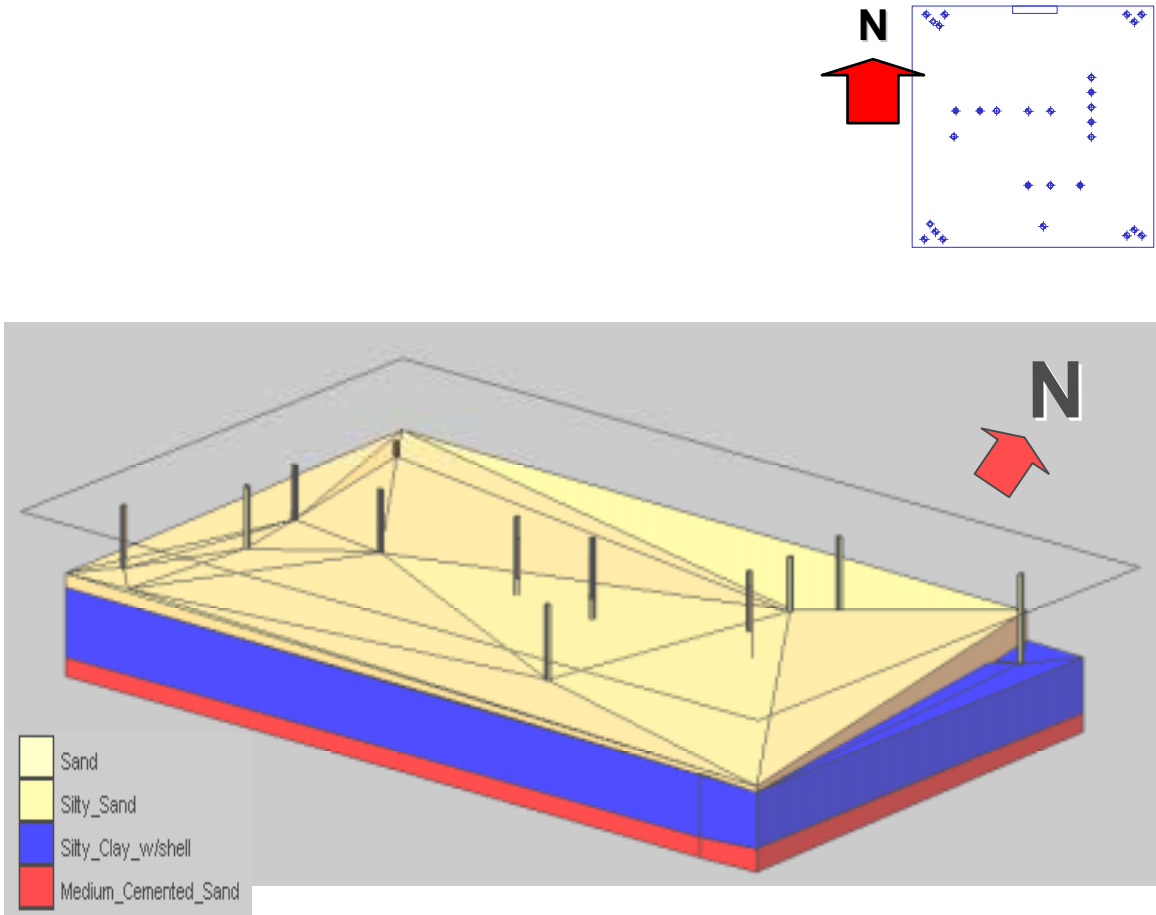

SE corner view at depth of 30 feet. The overlying hardpan, and two sand layers have been removed exposing the “silty-sand” layer.

Figure 37 Overhead view at depth of 30 ft.

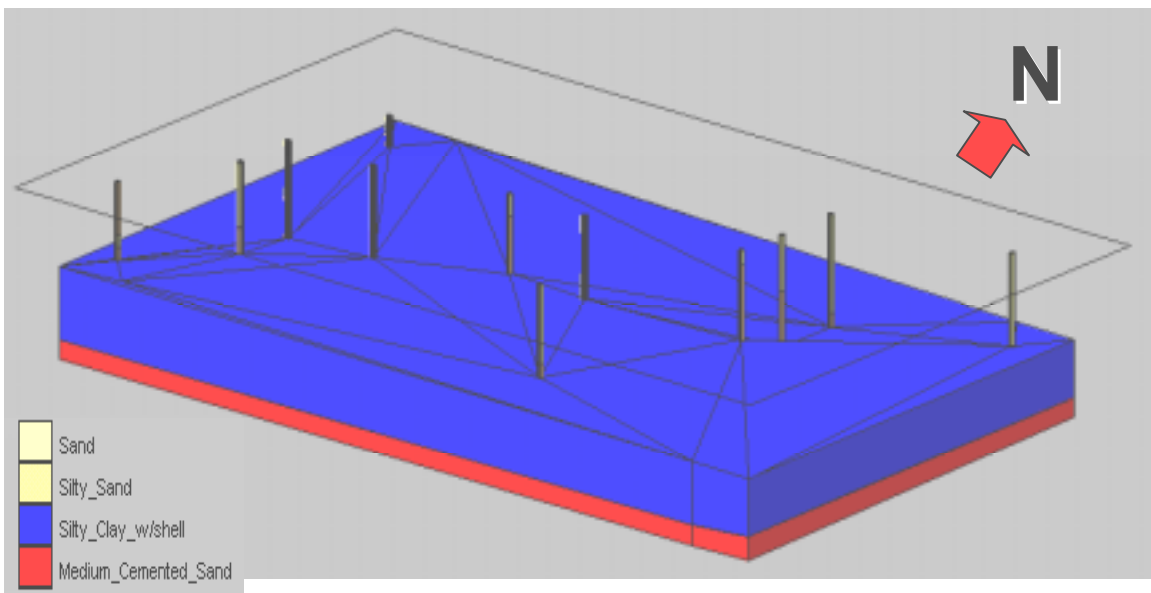
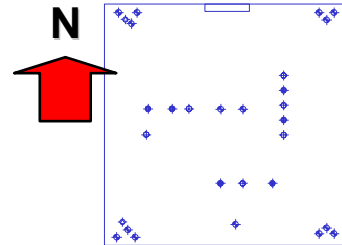

SE corner view at depth of 45 feet. The overlying hardpan, two sand layers, “silty-sand” layer have been removed exposing the “clay” layer.

Figure 38 Overhead view at depth of 45 ft.

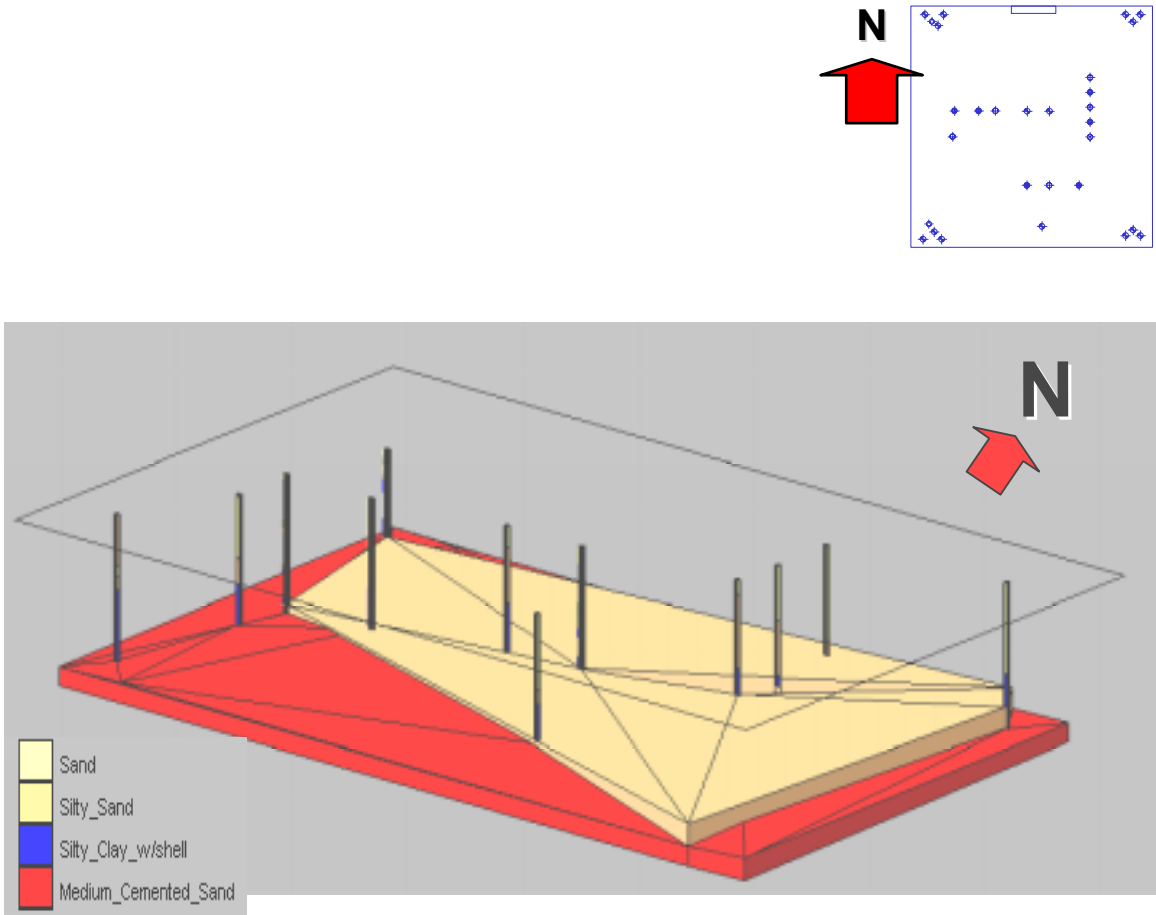

SE corner view at depth of 50 feet. The overlying hardpan, two sand layers, “silty-sand”, and “clay” layers have been removed exposing the medium cemented sand layer.

Figure 39 Overhead view at depth of 50 ft.

## **11. CONCLUSIONS**

Based upon the insitu tests performed the following conclusions are drawn:

1. The generalized soil profile from SPT borings is:
  - from 0–5 feet a Medium Sand;
  - from 5–33 feet Sand to Silty Sand;
  - from 33–52 feet Silt Clay to Clay Silt; and
  - from 52 –60 feet Medium Cemented Sand (Gravelly Sand).
2. From the center eastward a hard pan sand layer exists from about 10 to 15 ft.
3. Comparisons between SPT borings using a hollow stem auger vs. a cased hole using an automatic trip hammer revealed little difference in N values.
4. SPT energy measurements gave energy measurements of 82% for an automatic hammer, and only 65% for a safety hammer.
5. Comparisons between DMT borings using three different agencies revealed consistent results with little variation between agencies.
6. PMT measurements between two different agencies revealed substantial differences. These differences are attributed primarily to an oversized friction reducer on the tip, which caused an oversized hole and subsequent near hole disturbance leading to a softer response.

## **12. ADDITIONAL DATA**

The electronic spreadsheets for CPT, DMT, and PMT tests, and photos are contained on the enclosed CD.

## **APPENDIX**

### **Standard Penetration Test (SPT) Boring Logs**

The following figures show the boring logs obtained from SPT, performed at the site. The boring logs give a characterization of the soil profile of the site based on data interpretation of retrieved samples and “N” values versus depth. The exact location of the boring log is shown on Figure 3 of main report.

## STANDARD PENETRATION TEST BORING LOG BORING UNIVERSAL SPT 1

PROJECT: UCF Orlando

FILE No.:

BORING LOCATION: As per plan

DRILL CREW: Bob/Kevin

WATER OBSERVED AT DEPTH 3 FEET

DATE DRILLED: 01-29-02

| DEPTH<br>(FEET) | SYMBOLS<br>FIELD TEST DATA | SOIL DESCRIPTION                          | SAMPLE<br>No. | N<br>VALUE | N VALUE |   |   |   |   |   |   |   |   |   |    |  |  |  |  |  |
|-----------------|----------------------------|---|---------------|------------|---------|---|---|---|---|---|---|---|---|---|----|--|--|--|--|--|
|                 |                            |   |               |            | 0       | 1 | 2 | 3 | 4 | 5 | 6 | 7 | 8 | 9 | 10 |  |  |  |  |  |
| 0               |                            | Gray fine sand                            | 1             |            |         |   |   |   |   |   |   |   |   |   |    |  |  |  |  |  |
| 3               |                            | Light gray fine sand                      | 2             | 8          |         |   |   |   |   |   |   |   |   |   |    |  |  |  |  |  |
| 4               |                            | Brown slightly silty fine sand            | 3             | 10         |         |   |   |   |   |   |   |   |   |   |    |  |  |  |  |  |
| 5               |                            |   | 4             | 9          |         |   |   |   |   |   |   |   |   |   |    |  |  |  |  |  |
| 6               |                            | Dark brown slightly organic fine sand     | 5             | 19         |         |   |   |   |   |   |   |   |   |   |    |  |  |  |  |  |
| 7               |                            | Gray fine sand                            | 6             | 24         |         |   |   |   |   |   |   |   |   |   |    |  |  |  |  |  |
| 8               |                            |   | 7             | 24         |         |   |   |   |   |   |   |   |   |   |    |  |  |  |  |  |
| 10              |                            |   | 8             | 19         |         |   |   |   |   |   |   |   |   |   |    |  |  |  |  |  |
| 15              |                            | Light gray to white fine sand             | 9             | 19         |         |   |   |   |   |   |   |   |   |   |    |  |  |  |  |  |
| 20              |                            |   | 10            | 3          |         |   |   |   |   |   |   |   |   |   |    |  |  |  |  |  |
| 25              |                            | Light gray silty fine sand                | 11            | 0          |         |   |   |   |   |   |   |   |   |   |    |  |  |  |  |  |
| 30              |                            | Gray silty fine sand                      |               |            |         |   |   |   |   |   |   |   |   |   |    |  |  |  |  |  |
| 35              |                            | Gray silty sand with some shell fragments |               |            |         |   |   |   |   |   |   |   |   |   |    |  |  |  |  |  |

NOTES: Weight of the Hammer 140 lb Drop of the hammer 30"

FIELD TEST DATA ARE "BLOWS"/"INCHES DRIVEN"

140-LB HAMMER, 30-INCH FALL.

(ASTM D-1586)

## STANDARD PENETRATION TEST BORING LOG BORING UNIVERSAL SPT 1

PROJECT: UCF Orlando

FILE No.:

BORING LOCATION: As per plan

DRILL CREW: Bob/Kevin

WATER OBSERVED AT DEPTH 3 FEET

DATE DRILLED: 01-29-02

| DEPTH (FEET) | SYMBOLS<br>FIELD TEST DATA | SOIL DESCRIPTION  | SAMPLE No. | N VALUE | N VALUE |
|--------------|----------------------------|---|------------|---------|---------|
| 38.5         | 2/0<br>1/0<br>3/0          | Gray sandy clay   | 12         | 4       |         |
| 43.5         | 3/0<br>4/0<br>9/0          |   | 13         | 15      |         |
| 49.5         | 4/0<br>3/0<br>15/0         | Gray sandy clay with fragmented shells                        | 14         | 24      |         |
| 54.5         | 3/0<br>6/0<br>15/0         | Light gray silty fine sand with cemented fragments and shells | 15         | 21      |         |
| 59.5         | 5/0<br>7/0<br>12/0         |   | 10         | 19      |         |
| 60           |                            | Boring completed at depth 60 feet.                            |            |         |         |

NOTES: Weight of the Hammer 140 lb Drop of the hammer 30"

FIELD TEST DATA ARE "BLOWS"/"INCHES DRIVEN", 140-LB HAMMER, 30-INCH FALL. (ASTM D-1586)

## STANDARD PENETRATION TEST BORING LOG BORING UNIVERSAL SPT 2

PROJECT: UCF Orlando

FILE No.:

BORING LOCATION: As per plan

DRILL CREW: Bob/Kevin

WATER OBSERVED AT DEPTH 3 FEET

DATE DRILLED: 01-29-02

| DEPTH (FEET) | SYMBOLS<br>FIELD TEST DATA | SOIL DESCRIPTION                            | SAMPLE No. | N VALUE | N VALUE<br>***** |
|--------------|----------------------------|---|------------|---------|------------------|
| 0            |                            | Gray fine sand                              | 1          |         |                  |
| 4.0          | 40                         |   |            | 14      |                  |
| 5.0          | 50                         | Dark brown slightly organic fine sand       | 2          |         |                  |
| 6.0          | 60                         |   |            | 20      |                  |
| 7.0          | 70                         | Gray olive fine sand with traces of organic | 3          |         |                  |
| 8.0          | 80                         |   |            | 17      |                  |
| 9.0          | 90                         | Brown slightly silty fine sand              | 4          |         |                  |
| 10.0         | 100                        |   |            | 31      |                  |
| 11.0         | 110                        |   |            | 29      |                  |
| 12.0         | 120                        | Dark brown slightly silty fine sand         | 5          |         |                  |
| 13.0         | 130                        |   |            | 24      |                  |
| 14.0         | 140                        |   |            |         |                  |
| 15.0         | 150                        | Light gray fine sand                        | 6          |         |                  |
| 16.0         | 160                        |   |            | 14      |                  |
| 17.0         | 170                        |   |            |         |                  |
| 18.0         | 180                        | Light gray slightly silty fine sand         | 7          |         |                  |
| 19.0         | 190                        |   |            | 10      |                  |
| 20.0         | 200                        |   |            |         |                  |
| 21.0         | 210                        |   |            |         |                  |
| 22.0         | 220                        |   |            |         |                  |
| 23.0         | 230                        | Light gray to white fine sand               | 8          |         |                  |
| 24.0         | 240                        |   |            | 19      |                  |
| 25.0         | 250                        |   |            |         |                  |
| 26.0         | 260                        |   |            |         |                  |
| 27.0         | 270                        | Light gray silty fine sand                  | 9          |         |                  |
| 28.0         | 280                        |   |            | 3       |                  |
| 29.0         | 290                        |   |            |         |                  |
| 30.0         | 300                        |   |            |         |                  |
| 31.0         | 310                        |   |            |         |                  |
| 32.0         | 320                        |   |            |         |                  |
| 33.0         | 330                        | Blue gray sandy silt                        | 10         |         |                  |
| 34.0         | 340                        |   |            | 0       |                  |
| 35.0         | 350                        |   |            |         |                  |

NOTES:

FIELD TEST DATA ARE "BLOWS"/"INCHES DRIVEN"      140-LB HAMMER, 30-INCH FALL.      (ASTM D-1586)

## STANDARD PENETRATION TEST BORING LOG BORING UNIVERSAL SPT 2

PROJECT: UCF Orlando





FILE No.:

BORING LOCATION: As per plan

DRILL CREW: Bob/Kevin

WATER OBSERVED AT DEPTH 3 FEET

DATE DRILLED: 01-29-02

| DEPTH<br>(FEET) | SYMBOLS<br>FIELD TEST DATA  | SOIL DESCRIPTION   | SAMPLE<br>No. | N<br>VALUE | N VALUE<br>----- |
|-----------------|---|--|---------------|------------|------------------|
| 40              |    |  | 12            | 0          |                  |
| 45              |    | Gray sandy silt with cemented fragments                                | 13            | 8          |                  |
| 50              |  | Olive gray silty fine sand with shells and cemented fragments          | 14            | 13         |                  |
| 55              |  | Light gray slightly silty fine sand with shells and cemented fragments | 15            | 24         |                  |
| 60              |  | Boring completed at depth 60 feet.                                     | 16            | 31         |                  |
| 65              |   |  |               |            |                  |
| 70              |   |  |               |            |                  |

NOTES:

FIELD TEST DATA ARE "BLOWS"/"INCHES DRIVEN", 140-LB HAMMER, 30-INCH FALL. (ASTM D-1586)



## STANDARD PENETRATION TEST BORING LOG

### BORING Bartow SPT 1

PROJECT: UCF Orlando

FILE No.:

BORING LOCATION: As per plan

DRILL CREW: Landers, Kaufman

WATER OBSERVED AT DEPTH 3 FEET

DATE DRILLED: 01-29-02

| DEPTH (FEET) | SYMBOLS<br>FIELD TEST DATA | SOIL DESCRIPTION  | SAMPLE No. | N VALUE | N VALUE |
|--------------|----------------------------|---|------------|---------|---------|
| 0            | 038                        | Very loose olive sandy silt with some traces of clay            | 9          | 0       |         |
| 40           | 1/8<br>012                 | Very loose Olive gray silty fine sand with some traces of shell | 10         | 0       |         |
| 45           | 3/8<br>2/8<br>2/8          |   | 11         | 4       |         |
| 50           | 3/8<br>3/8<br>4/8          | Olive gray silty sand with some shell and cemented fragments    | 12         | 7       |         |
| 55           | 7/8<br>8/8<br>7/8          | Gray cemented sand with traces of shell                         | 13         | 16      |         |
| 60           | 8/8<br>6/8<br>8/2          | Gray cemented sand and shells fragments                         | 14         | 50+     |         |
|              |                            | Boring hole terminated at depth 61.2 feet                       |            |         |         |

NOTES:

FIELD TEST DATA ARE "BLOWS"/"INCHES DRIVEN" 140-LB HAMMER, 30-INCH FALL (ASTM D-1586)

## STANDARD PENETRATION TEST BORING LOG BORING Bartow SPT 2

PROJECT: UCF Orlando















FILE No.:

BORING LOCATION: As per plan

DRILL CREW: Landers, Kaufman

WATER OBSERVED AT DEPTH 3 FEET

DATE DRILLED: 01-30-02

| DEPTH (FEET) | SYMBOLS<br>FIELD TEST DATA  | SOIL DESCRIPTION                 | SAMPLE No. | N VALUE | N VALUE<br>*****  |
|--------------|---|----------------------------------|------------|---------|---|
| 0            |    | Moist loose gray fine Sand       | 1          | 7       |    |
| 5            |    | Brown fine sand slightly organic | 2          | 20      |    |
| 10           |   | Brown fine sand slightly silty   | 3          | 22      |   |
| 15           |  | Gray wet loose fine sand         | 4          | 8       |  |
| 20           |  |                                  | 6          | 6       |  |
| 25           |  |                                  | 7          | 20      |  |
| 30           |  |                                  | 8          | 4       |  |
| 35           |   |                                  |            |         |   |

NOTES: Type of Hammer automatic

FIELD TEST DATA ARE "BLOWS"/"INCHES DRIVEN"

140-LB HAMMER, 30-INCH FALL.

(ASTM D-1586)

## STANDARD PENETRATION TEST BORING LOG

### BORING Bartow SPT 2

PROJECT: UCF Orlando

FILE No.:

BORING LOCATION: As per plan

DRILL CREW: Landers, Kaufman

WATER OBSERVED AT DEPTH 3 FEET

DATE DRILLED: 01-30-02

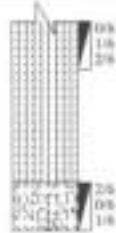
| DEPTH<br>(FEET) | SYMBOLS<br>FIELD TEST DATA  | SOIL DESCRIPTION                          | SAMPLE<br>No. | N<br>VALUE | N VALUE |
|-----------------|---|---|---------------|------------|---------|
| 38              |  | Very loose light gray olive sandy silt    | 9             | 2          | .....   |
| 40              |   | Very loose olive gray silty fine sand     | 10            | 1          | .....   |
| 41.5            |   | Boring hole terminated at depth 41.5 feet |               |            | .....   |
| 43              |   |   |               |            | .....   |
| 45              |   |   |               |            | .....   |
| 50              |   |   |               |            | .....   |
| 55              |   |   |               |            | .....   |
| 60              |   |   |               |            | .....   |
| 65              |   |   |               |            | .....   |
| 70              |   |   |               |            | .....   |

NOTES: Type of Hammer automatic

FIELD TEST DATA ARE "BLOWS"/"INCHES DRIVEN", 140-LB HAMMER, 30-INCH FALL. (ASTM D-1586)

## STANDARD PENETRATION TEST BORING LOG BORING NODARSE SPT 1

PROJECT: UCF Orlando

FILE No.:

BORING LOCATION: As per plan

DRILL CREW: Wick/Jason

WATER OBSERVED AT DEPTH 3 FEET

DATE DRILLED: 01-29-02

| DEPTH (FEET) | SYMBOLS<br>FIELD TEST DATA | SOIL DESCRIPTION                          | SAMPLE No. | N VALUE | N VALUE |
|--------------|----------------------------|---|------------|---------|---------|
| 0            |                            | Dark gray fine sand (topsoil)             | 1          | 7       |         |
| 0.5          |                            | Olive gray fine sand                      | 2          | 8       |         |
| 1            |                            | Gray fine sand                            | 3          | 10      |         |
| 1.5          |                            | Light gray sand                           | 4          | 11      |         |
| 2            |                            |   |            | 7       |         |
| 2.5          |                            |   |            | 11      |         |
| 3            |                            |   | 3          | 2       |         |
| 4            |                            | Light brown fine sand                     | 6          | 5       |         |
| 5            |                            | Light gray slightly silty fine sand       | 7          | 1       |         |
| 6            |                            | Dark gray sandy silt                      | 8          | 0       |         |
| 7            |                            | Dark gray silty sand with shell fragments | 9          | 7       |         |

NOTES: HAMMER DROP 30" W = 140 LB  
USING DRILING MUD(BENTONITE)

FIELD TEST DATA ARE "BLOWS"/"INCHES DRIVEN"

140-LB HAMMER, 30-INCH FALL.

(ASTM D-1586)

## STANDARD PENETRATION TEST BORING LOG BORING NODARSE SPT 1

PROJECT: UCF Orlando

FILE No.:

BORING LOCATION: As per plan

DRILL CREW: Wick/Jason

WATER OBSERVED AT DEPTH 3 FEET

DATE DRILLED: 01-29-02

| DEPTH (FEET) | SYMBOLS<br>FIELD TEST DATA | SOIL DESCRIPTION  | SAMPLE No. | N VALUE | N VALUE<br>***** |
|--------------|----------------------------|---|------------|---------|------------------|
| 38           |                            | Blue gray clay  | 10         | 4       |                  |
| 43           |                            | Gray sandy clay   | 11         | 4       |                  |
| 48           |                            | Gray slightly clay fine sand with shell fragments             | 12         | 11      |                  |
| 53           |                            | Light gray sandy silty with some shell and cemented fragments | 13         | 9       |                  |
| 58           |                            | Boring hole terminated at depth 60 feet                       | 14         | 21      |                  |

NOTES: HAMMER DROP 30" W = 140 LB  
USING DRILING MUD(BENTONITE)  
FIELD TEST DATA ARE "BLOWS"/"INCHES DRIVEN" 140-LB HAMMER, 30-INCH FALL. (ASTM D-1586)



## STANDARD PENETRATION TEST BORING LOG BORING GEC-1

PROJECT: UCF Orlando

FILE No.:

BORING LOCATION: As per plan

DRILL CREW: PJB/TJR

WATER OBSERVED AT DEPTH 1.5 FEET

DATE DRILLED: 10-1-02

| DEPTH (FEET) | SYMBOLS<br>FIELD TEST DATA | SOIL DESCRIPTION  | SAMPLE No. | N VALUE | N VALUE |
|--------------|----------------------------|---|------------|---------|---------|
|              |                            | Shelby tube from 35.5 to 37.5 feet (recovery 24 inch)         |            |         |         |
|              |                            | Loose light gray fine sand with some silt                     | 12         | 4       |         |
|              |                            | Loose light gray fine sand with some cemented sand and shell. | 13         | 5       |         |
|              |                            | tan sand with some phosphate and cemented sand.               | 14         | 6       |         |
|              |                            | Gray sandy silt with some clay and phosphate shells           | 15         | 6       |         |
|              |                            | Shelby tube from 45.5 to 47.5 feet (recovery 0 inch)          |            |         |         |
|              |                            |   |            | 5       |         |
|              |                            |   |            | 7       |         |
|              |                            | Gray silt with some clay phosphates and shells                | 16         | 9       |         |
|              |                            | Slightly silty light gray cemented sand with some shell       | 17         | 19      |         |
|              |                            | Shelby tube from 55.5 to 56.5 feet (recovery 12 inch)         |            |         |         |
|              |                            |   |            | 14      |         |
|              |                            | Silty shell   | 18         | 11      |         |
|              |                            |   |            | 16      |         |
|              |                            | Light brown sand  | 19         | 14      |         |
|              |                            | Gray cemented silty sand with some shell                      | 20         | 19      |         |
|              |                            | Soft tan silty weathered limestone                            | 21         | 20      |         |

NOTES: Weight of the Hammer 140 lbs Drop of the hammer 30" Using Grout hole and casing at 135 feet.

FIELD TEST DATA ARE "BLOWS"/"INCHES DRIVEN", 140-LB HAMMER, 30-INCH FALL. (ASTM D-1586)



## STANDARD PENETRATION TEST BORING LOG BORING GEC-1

PROJECT: UCF Orlando

FILE No.:

BORING LOCATION: As per plan

DRILL CREW: PJB/IJR

WATER OBSERVED AT DEPTH 1.5 FEET

DATE DRILLED: 10-1-02

| DEPTH (FEET)  | SYMBOLS<br>FIELD TEST DATA | SOIL DESCRIPTION  | SAMPLE No. | N VALUE | N VALUE |
|---------------|----------------------------|---|------------|---------|---------|
| 108.5 - 110.5 | 3/6<br>12/6<br>50/5.5      | Regain drill fluid  |            | 62      | 62      |
| 110.5 - 112.5 | 37/6<br>21/6<br>12/6       | Tan calcareous Slightly silty sand weather limestone                              | 26         | 33      |         |
| 112.5 - 114.5 | 4/6<br>4/6<br>9/6          | Tan calcareous Slightly silty sand weather limestone with Shell                   | 27         | 13      |         |
| 114.5 - 116.5 | 6/6<br>8/6<br>12/6         |   |            | 20      |         |
| 116.5 - 118.5 | 14/6<br>8/6<br>7/6         | Tan calcareous Slightly silty sand weather limestone with some shell              | 28         | 15      |         |
| 118.5 - 120.5 | 9/6<br>16/6<br>11/6        |   |            | 27      |         |
| 120.5 - 122.5 | 50/5.5                     | Tan calcareous Slightly silty sand weather limestone with some shell              | 29         | 50+     | 50+     |
| 122.5 - 124.5 | 46/6<br>28/6<br>35/6       |   |            | 63      | 63      |
| 124.5 - 126.5 | 50/1                       |   |            | 50+     | 50+     |
| 126.5 - 128.5 | 50/2                       | not recovery  |            |         |         |
| 128.5 - 130.5 | 37/6<br>50/5               | Regain drilling fluid at 133 feet, installation of casing at 135 feet no recovery |            | 50+     | 50+     |
| 130.5 - 132.5 | 20/6<br>29/6<br>30/6       | Tan calcareous light gray sandy weather limestone                                 | 30         | 59      | 59      |
| 132.5 - 134.5 | 50/4                       |   |            | 50+     | 50+     |

NOTES: Weight of the Hammer 140 lbs Drop of the hammer 30" Using Grout hole and casing at 135 feet.

FIELD TEST DATA ARE "BLOWS"/"INCHES DRIVEN". 140-LB HAMMER, 30-INCH FALL. (ASTM D-1586)

## STANDARD PENETRATION TEST BORING LOG BORING GEC-1

PROJECT: UCF Orlando

FILE No.:

BORING LOCATION: As per plan

DRILL CREW: PJB/TJR

WATER OBSERVED AT DEPTH 1.5 FEET

DATE DRILLED: 10-1-02

| DEPTH (FEET) | SYMBOLS<br>FIELD TEST DATA | SOIL DESCRIPTION | SAMPLE No. | N VALUE | N VALUE |
|--------------|----------------------------|------------------|------------|---------|---------|
| 145          | 44/6<br>50/5               |                  |            | 50+     | 50+     |
|              | 48/6<br>17/6<br>24/6       |                  |            | 41      |         |
| 150          | 31/6<br>50/1               |                  |            | 50+     | 50+     |
|              | 14/6<br>11/6<br>11/6       | Sand             |            | 22      |         |
| 155          | 10/6<br>11/6<br>11/6       |                  |            | 22      |         |
|              | 7/6<br>8/6<br>11/6         |                  |            | 19      |         |
| 160          | 12/6<br>16/6<br>9/6        |                  |            | 25      |         |
|              | 50/5                       | Tan sand         | 31         | 50+     | 50+     |
| 165          | 12/6<br>13/6<br>20/6       |                  |            | 33      |         |
|              | 13/6<br>11/6<br>14/6       |                  |            | 25      |         |
| 170          | 16/6<br>39/6<br>41/6       |                  |            | 80      | 80      |
|              | 16/6<br>31/6<br>22/6       |                  |            | 53      | 53      |
| 175          | 10/6<br>50/4               |                  |            | 50+     | 50+     |

NOTES: Weight of the Hammer 140 lbs Drop of the hammer 30" Using Grout hole and casing at 135 feet.

FIELD TEST DATA ARE "BLOWS"/"INCHES DRIVEN". 140-LB HAMMER, 30-INCH FALL. (ASTM D-1586)

## STANDARD PENETRATION TEST BORING LOG BORING GEC-1

PROJECT: UCF Orlando

FILE No.:

BORING LOCATION: As per plan

DRILL CREW: PJB/TJR

WATER OBSERVED AT DEPTH 1.5 FEET

DATE DRILLED: 10-1-02

| DEPTH (FEET) | SYMBOLS<br>FIELD TEST DATA | SOIL DESCRIPTION                      | SAMPLE No. | N VALUE | N VALUE |
|--------------|----------------------------|---------------------------------------|------------|---------|---------|
| 176          | 17/6                       |                                       |            | 30      |         |
| 14/6         | 14/6                       |                                       |            |         |         |
| 16/6         | 16/6                       |                                       |            |         |         |
| 29/6         | 29/6                       |                                       |            | 79      |         |
| 29/6         | 29/6                       |                                       |            |         |         |
| 50/6         | 50/6                       |                                       |            |         |         |
| 50/4.5       | 50/4.5                     |                                       |            | 50+     |         |
| 50/0         | 50/0                       |                                       |            | 50+     |         |
| 50/1.5       | 50/1.5                     |                                       |            | 50+     |         |
| 50/5.5       | 50/5.5                     | Tan Silty weathered limestone         | 32         | 50+     |         |
| 15/6         | 15/6                       |                                       |            | 9       |         |
| 50/3         | 50/3                       |                                       |            |         |         |
| 16/6         | 16/6                       | Gray sand                             |            | 24      |         |
| 12/6         | 12/6                       |                                       |            |         |         |
| 12/6         | 12/6                       |                                       |            |         |         |
| 50/3         | 50/3                       |                                       |            | 50+     |         |
| 6/6          | 6/6                        |                                       |            | 18      |         |
| 6/6          | 6/6                        |                                       |            |         |         |
| 12/6         | 12/6                       |                                       |            |         |         |
|              |                            | Boring completed at depth 200.5 feet. |            |         |         |

NOTES: Weight of the Hammer 140 lbs Drop of the hammer 30" Using Grout hole and casing at 135 feet.

FIELD TEST DATA ARE "BLOWS"/"INCHES DRIVEN", 140-LB HAMMER, 30-INCH FALL. (ASTM D-1586)



## STANDARD PENETRATION TEST BORING LOG BORING GEC-2

PROJECT: UCF Orlando

FILE No.:

BORING LOCATION: As per plan

DRILL CREW: TJR

WATER OBSERVED AT DEPTH 1.5 FEET

DATE DRILLED: 10-14-02

| DEPTH<br>(FEET) | SYMBOLS<br>FIELD TEST DATA | SOIL DESCRIPTION  | SAMPLE<br>No. | N<br>VALUE | N VALUE |   |   |   |   |   |   |   |   |    |  |  |  |  |  |  |
|-----------------|----------------------------|---|---------------|------------|---------|---|---|---|---|---|---|---|---|----|--|--|--|--|--|--|
|                 |                            |   |               |            | 1       | 2 | 3 | 4 | 5 | 6 | 7 | 8 | 9 | 10 |  |  |  |  |  |  |
|                 |                            | Shelby tube from 35.5 to 37.5 feet (recovery 24 inch)   |               |            |         |   |   |   |   |   |   |   |   |    |  |  |  |  |  |  |
|                 |                            | Soft gray silt with some clay                           | 9             | 4          |         |   |   |   |   |   |   |   |   |    |  |  |  |  |  |  |
| 40              |                            |   |               | 4          |         |   |   |   |   |   |   |   |   |    |  |  |  |  |  |  |
|                 |                            | Loose sandy silt with some phosphate and cemented sand. | 10            | 2          |         |   |   |   |   |   |   |   |   |    |  |  |  |  |  |  |
|                 |                            | Shelby tube from 43 to 45 feet (recovery 0 inch)        |               |            |         |   |   |   |   |   |   |   |   |    |  |  |  |  |  |  |
| 45              |                            | loose silty fine sand some clay and phosphate shells    | 11            | 7          |         |   |   |   |   |   |   |   |   |    |  |  |  |  |  |  |
|                 |                            | loose silty fine sand and cemented sand with shells     | 12            | 8          |         |   |   |   |   |   |   |   |   |    |  |  |  |  |  |  |
|                 |                            | loose cemented sand and shells                          | 13            | 9          |         |   |   |   |   |   |   |   |   |    |  |  |  |  |  |  |
| 50              |                            |   |               | 12         |         |   |   |   |   |   |   |   |   |    |  |  |  |  |  |  |
|                 |                            | Shelby tube from 55.5 to 57 feet (recovery 15 inch)     |               | 16         |         |   |   |   |   |   |   |   |   |    |  |  |  |  |  |  |
| 55              |                            |   |               | 12         |         |   |   |   |   |   |   |   |   |    |  |  |  |  |  |  |
|                 |                            |   |               | 21         |         |   |   |   |   |   |   |   |   |    |  |  |  |  |  |  |
| 60              |                            |   |               | 50+        |         |   |   |   |   |   |   |   |   |    |  |  |  |  |  |  |
|                 |                            | Tan sand with shell and cemented fragments              | 14            | 14         |         |   |   |   |   |   |   |   |   |    |  |  |  |  |  |  |
| 65              |                            | Gray cemented silty sand with some shell                | 15            | 17         |         |   |   |   |   |   |   |   |   |    |  |  |  |  |  |  |
| 70              |                            |   |               | 16         |         |   |   |   |   |   |   |   |   |    |  |  |  |  |  |  |

NOTES: Weight of the Hammer 140 lbs Drop of the hammer 30" Grout hole, casing at 80"

FIELD TEST DATA ARE "BLOWS"/"INCHES DRIVEN", 140-LB HAMMER, 30-INCH FALL. (ASTM D-1586)



## STANDARD PENETRATION TEST BORING LOG BORING GEC-2

PROJECT: UCF Orlando

FILE No.:

BORING LOCATION: As per plan

DRILL CREW: TJR

WATER OBSERVED AT DEPTH 1.5 FEET

DATE DRILLED: 10-14-02

| DEPTH<br>(FEET) | SYMBOLS<br>FIELD TEST DATA | SOIL DESCRIPTION                                       | SAMPLE<br>No. | N<br>VALUE | N VALUE |     |
|-----------------|----------------------------|--|---------------|------------|---------|-----|
|                 |                            |  |               |            | 0       | 50  |
| 110             |                            | Tan calcareous sandy weather limestone                 | 21            | 78         | 50+     | 78  |
| 115             |                            | Tan calcareous silty sand weather limestone            | 22            | 53         | 50+     | 53  |
| 120             |                            | Tan calcareous silty sand weather limestone with Shell | 23            | 14         | 50+     | 14  |
| 125             |                            | Tan calcareous silty sand weather limestone with shell | 24            | 19         | 50+     | 19  |
| 130             |                            |  |               | 14         | 50+     | 14  |
| 135             |                            | not recovery   |               | 49         | 50+     | 49  |
| 140             |                            |  |               | 50+        | 50+     |     |
| 135             |                            | Tan calcareous sandy weather limestone with some shell | 25            | 50+        | 50+     | 50+ |
| 140             |                            |  |               | 50+        | 50+     |     |
| 140             |                            |  |               | 73         | 73      |     |
| 140             |                            |  |               | 52         | 52      |     |
| 140             |                            |  |               | 50+        | 50+     |     |

NOTES: Weight of the Hammer 140 lbs Drop of the hammer 30" Grout hole, casing at 80"

FIELD TEST DATA ARE "BLOWS"/"INCHES DRIVEN", 140-LB HAMMER, 30-INCH FALL. (ASTM D-1586)

## STANDARD PENETRATION TEST BORING LOG BORING GEC-2

PROJECT: UCF Orlando

FILE No.:

BORING LOCATION: As per plan

DRILL CREW: TJR

WATER OBSERVED AT DEPTH 1.5 FEET

DATE DRILLED: 10-14-02

| DEPTH (FEET) | SYMBOLS<br>FIELD TEST DATA                  | SOIL DESCRIPTION                                       | SAMPLE No. | N VALUE   | N VALUE<br>6 8 10 12 14 16 18 20 22 24 26 28 30 32 34 36 38 40 42 44 46 48 50+ |
|--------------|---|--|------------|-----------|--|
| 145          | 50/3<br>11/6<br>28/6<br>50/4                |  |            | 50+<br>78 | 50+<br>78  |
| 150          | 50/5.5<br>10/6<br>12/6<br>13/6              | Tan calcareous sandy weather limestone with some shell | 26         | 50+<br>25 | 50+<br>25  |
| 155          | 25/6<br>9/6<br>10/6<br>11/6<br>6/6<br>9/6   |  |            | 19<br>15  |  |
| 160          | 7/6<br>8/6<br>7/6<br>13/6<br>12/6<br>15/6   |  |            | 15<br>27  |  |
| 165          | 14/6<br>15/6<br>20/6<br>11/6<br>9/6<br>11/6 |  |            | 35<br>20  |  |
| 170          | 8/6<br>6/6<br>6/6<br>5/6<br>13/6<br>18/6    |  |            | 12<br>31  |  |
| 175          | 11/6<br>10/6<br>11/6<br>12/6<br>11/6        |  |            | 21<br>61  | 61   |

NOTES: Weight of the Hammer 140 lbs Drop of the hammer 30" Grout hole, casing at 80"

FIELD TEST DATA ARE "BLOWS"/"INCHES DRIVEN". 140-LB HAMMER, 30-INCH FALL. (ASTM D-1586)

## STANDARD PENETRATION TEST BORING LOG BORING GEC-2

PROJECT: UCF Orlando

FILE No.:

BORING LOCATION: As per plan

DRILL CREW: TJR

WATER OBSERVED AT DEPTH 1.5 FEET

DATE DRILLED: 10-14-02

| DEPTH (FEET) | SYMBOLS<br>FIELD TEST DATA   | SOIL DESCRIPTION                                       | SAMPLE No. | N VALUE | N VALUE |
|--------------|------------------------------|--|------------|---------|---------|
| 145          | 50:3<br>11:6<br>28:6<br>50:4 |  |            | 50+     | 50+     |
|              | 50:5.5                       |  |            | 78      | 78      |
| 150          | 10:6<br>12:6<br>13:6         | Tan calcareous sandy weather limestone with some shell | 26         | 50+     | 50+     |
|              | 25:6<br>9:6<br>10:6          |  |            | 25      |         |
| 155          | 11:6<br>6:6<br>9:6           |  |            | 19      |         |
|              | 7:6<br>8:6<br>7:6            |  |            | 15      |         |
| 160          | 13:6<br>12:6<br>15:6         |  |            | 15      |         |
|              | 14:6<br>15:6<br>20:6         |  |            | 27      |         |
| 165          | 11:6<br>9:6<br>11:6          |  |            | 35      |         |
|              | 8:6<br>6:6<br>6:6            |  |            | 20      |         |
| 170          | 5:6<br>13:6<br>18:6          |  |            | 12      |         |
|              | 11:6<br>10:6<br>11:6         |  |            | 31      |         |
| 175          | 12:6<br>11:6                 |  |            | 21      |         |
|              |                              |  |            | 61      | 61      |

NOTES: Weight of the Hammer 140 lbs Drop of the hammer 30" Grout hole, casing at 80"

FIELD TEST DATA ARE "BLOWS"/"INCHES DRIVEN", 140-LB HAMMER, 30-INCH FALL (ASTM D-1586)