Report No. BC354 RPWO #47 – Part 1
FINAL REPORT

March 2002

Contract Title: Evaluation of Precast Box Culvert Systems
UF Project No. 4910 4504 857 12
Contract No. BC354 RPWO #47 – Part 1

EVALUATION OF PRECAST BOX CULVERT SYSTEMS

Principal Investigators:

Ronald A. Cook
David Bloomquist

Graduate Research Assistant:

Whitney D. Zink

Project Manager:

Marcus H. Ansley

Department of Civil & Coastal Engineering
College of Engineering
University of Florida
Gainesville, Florida 32611

Engineering and Industrial Experiment Station



1. Report No. BC354 RPWO #47 – Part 1	2. Government Accession No.	3. Recipient's Catalog No.	
4. Title and Subtitle Evaluation of Precast Box Culvert Systems		5. Report Date March 2002	
7. Author(s) R. A. Cook and W. D. Zink		6. Performing Organization Code	
9. Performing Organization Name and Address University of Florida Department of Civil Engineering 345 Weil Hall / P.O. Box 116580 Gainesville, FL 32611-6580		8. Performing Organization Report No. 4910 4504 857 12	
12. Sponsoring Agency Name and Address Florida Department of Transportation Research Management Center 605 Suwannee Street, MS 30 Tallahassee, FL 32301-8064		10. Work Unit No. (TRAIS)	
15. Supplementary Notes Prepared in cooperation with the Federal Highway Administration		11. Contract or Grant No. BC354 RPWO #47 – Part 1	
16. Abstract <p>The purpose of this research was to identify the types and overall performance of precast box culvert systems by surveying the FDOT Districts and other states in the United States. The project included the following: literature review, site and plant inspections, a survey of FDOT Districts, and a survey of the other state DOTs. Based on the results of this study it is recommended that Florida continue construction and installation of 4-sided single and multiple cell precast box culverts, review the plant inspection process, research and approve a joint filler material, continue to completely wrap the top and sides of each joint with filter fabric, develop and implement an inventory tracking database, develop and implement a guideline requiring all final inspections to be visually documented, revise the FDOT Specifications Section 410, and consider the possibility of implementing a set of standard details for single and multiple cell precast box culvert installations.</p>		13. Type of Report and Period Covered Final Report	
17. Key Words Precast Box Culverts, Box Culverts, Arch Culverts		18. Distribution Statement No restrictions. This document is available to the public through the National Technical Information Service, Springfield, VA, 22161	
19. Security Classif. (of this report) Unclassified	20. Security Classif. (of this page) Unclassified	21. No. of Pages 103	22. Price

DISCLAIMER

“The opinions, findings and conclusions expressed in this publication are those of the authors and not necessarily those of the Florida Department of Transportation or the U.S. Department of Transportation.

Prepared in cooperation with the State of Florida Department of Transportation and the U.S. Department of Transportation”

EVALUATION OF PRECAST BOX CULVERT SYSTEMS

Contract No. BC 354 RPWO #47 – Part 1
UF No. 4910 4504 857 12

Principal Investigators:	Ronald A. Cook David Bloomquist
Graduate Research Assistant:	Whitney D. Zink
FDOT Technical Coordinator:	Marcus H. Ansley

Engineering and Industrial Experiment Station
Department of Civil Engineering
University of Florida
Gainesville, Florida

March 2002

TABLE OF CONTENTS

Chapter 1	Introduction	1
1.1	Objective	1
1.2	Scope	1
1.3	Background Information	1
	1.3.1 ASTM Standards	1
	1.3.2 Types of Precast Culverts	3
	1.3.3 Standard Sizes and Available Options	6
Chapter 2	Literature Review	8
2.1	General	8
2.2	Precast Box Culverts	8
2.3	Three-sided Precast Concrete Arch Culverts	12
2.4	Summary	16
Chapter 3	Florida Site Visits	18
3.1	General	18
3.2	Tallahassee Trip	18
	3.2.1 Intersection of Lake Bradford Rd. and Epps Dr.	18
	3.2.2 Near the FSU Track Stadium	19
	3.2.3 Intersection of Thomasville Rd. and Velda Dairy Rd.	21
	3.2.4 Contractor's Opinion	21
3.3	Hanson Precast Plant Tour	22
3.4	Summary	24
Chapter 4	Results of Florida Surveys	25
4.1	General	25
4.2	District Survey	25
4.3	Shop Drawing Review Questions	30
4.4	Review of Current FDOT Specifications	31
	4.4.1 Section 407: Three-sided Precast Culverts	31
	4.4.2 Section 410: Precast Concrete Box Culverts	32
4.5	Summary	33

Chapter 5	Results of State Surveys	35
5.1	General	35
5.2	State Survey	35
5.3	Problems and Solutions	61
5.4	State Survey Summary	65
5.5	State Specification/Detail Summary	68
Chapter 6	Conclusions and Recommendations	71
6.1	Summary	71
6.2	Conclusions	73
6.3	Recommendations	74
6.4	Summary of Recommendations	78
References	80
Appendix	82
A	Florida District Contact List	
B	Florida District Survey Matrix	
C	State Contact List	
D	State Survey Matrix	
E	State Specification Matrix	
F	State Specifications and Details	
	Illinois Specifications	
	Kansas Specifications & Details	
	Minnesota Specifications & Details	
	Nevada Specifications	
	New Hampshire Specifications	
	New Jersey Specifications & Details	
	New York Specifications	
	Ohio Specifications	
	Oregon Details	
	Pennsylvania CON/SPAN Specifications & Details	
	Tennessee Specifications & Details	
	Texas Details	

LIST OF TABLES

Table 4.1	Percentage of Precast Box Culverts in Florida	33
Table 5.1	Percentage of Precast Box Culverts in Other States	65
Table 5.2	Types of Precast Culverts in Other States	66
Table 5.3	Concrete Cover Requirements in Other States	70

LIST OF FIGURES

Figure 1.1	ASTM C 1433 Typical Box Sections	2
Figure 1.2	ASTM C 1433 Design Requirements for a 6' x 6' Precast Box Culvert	2
Figure 1.3	Single Cell Square/Rectangular Culvert	3
Figure 1.4	Multiple Cell Square/Rectangular Culvert	3
Figure 1.5	Three-sided Culvert with Footer Slabs and a Flat Top	4
Figure 1.6	Three-sided U-shaped Culvert with a Flat Top Slab	4
Figure 1.7	Two Three-sided U-shaped Culverts with a Mid-height Connection Joint	5
Figure 1.8	CON/SPAN Single Cell Precast Arch Culvert	5
Figure 1.9	CON/SPAN Double Cell Precast Arch Culvert	5
Figure 1.10	CON/SPAN Arch Culvert System Components	7
Figure 3.1	Intersection of Lake Bradford Rd. and Epps Dr. - Exterior View of Culvert	18
Figure 3.2	Intersection of Lake Bradford Rd. and Epps Dr. - Exterior View of Culvert	18
Figure 3.3	Near FSU Track Stadium - Interior View of Joined Culvert Sections	19
Figure 3.4	Near FSU Track Stadium - Joint Between Culvert Sections	20
Figure 3.5	Near FSU Track Stadium - Exposed and Corroded Reinforcing Steel	20

Figure 3.6	Intersection of Thomasville Rd. and Velda Dairy Rd. - Interior View of Culvert	21
Figure 3.7	Intersection of Thomasville Rd. and Velda Dairy Rd. – Interior View of Joint	21
Figure 3.8	Hanson Plant Tour – Interior Form	23
Figure 3.9	Hanson Plant Tour – Exterior Form	23
Figure 3.10	Hanson Plant Tour – Series of 10’ x 5’ Precast Box Culvert Sections	23
Figure 3.11	Hanson Plant Tour – Single Cell Precast Box Culvert	23
Figure 3.12	Hanson Plant Tour – Tongue and Groove Joint	23
Figure 3.13	Hanson Typical Joint Detail	24
Figure 3.14	Hanson Joint Cross Section	24
Figure 5.1	Kansas - Joint Sealer & Geotextile Fabric	39
Figure 5.2	Kansas - External Sealing Band	40
Figure 5.3	Kansas - Extruded Rubber Gasket & Geotextile Fabric	40
Figure 5.4	New Jersey – Typical Headwall Detail	47
Figure 5.5	New Jersey – Typical Toewall Detail.	47
Figure 5.6	New Jersey – Box Culvert End Elevation	48
Figure 5.7	New Jersey – Joint Detail	48
Figure 5.8	Ohio – Inlet End Detail	52
Figure 5.9	Ohio – Outlet End Detail	52
Figure 5.10	Pennsylvania – CON/SPAN Joint Wrap Detail	54
Figure 5.11	South Dakota – Typical Tie Bolt Assembly	55
Figure 5.12	Texas – 3’ Span Sample Culvert Data	58
Figure 5.13	Texas - C 789 Standard Drawing	59
Figure 5.14	Texas – Multiple Unit Placement Details	59

CHAPTER 1 INTRODUCTION

1.1 Objective

Frequently, alternatives to the traditional cast-in-place box culvert system are presented to the Florida Department of Transportation for review. Currently, there is no clear-cut procedure for evaluating these systems. The objective of this research is to develop guidelines for the evaluation of precast box culvert systems. The guidelines will be developed based on a survey of the performance of precast box culvert systems previously installed in the state of Florida and a survey of systems used by other states.

1.2 Scope

The project included the following:

- A literature review
- A survey of systems used in the state of Florida
- A survey of systems used by other states
- Assessment of precast box culvert option
- A project report

1.3 Background Information

The following gives a summary of the ASTM Standards, types of precast culverts, standard sizes and available options for precast box culverts.

1.3.1 ASTM Standards

The following ASTM Standards are used for precast box culverts.

- ASTM C 850 / AASHTO M 273 - Precast Reinforced Concrete Box Sections for Culverts, Storm Drains, and Sewers with Less Than 2 ft. of Cover Subjected to Highway Loading – This standard was discontinued in 2000 and replaced by ASTM C 1433
- ASTM C 789 / AASHTO M 259 - Precast Reinforced Concrete Box Sections for Culverts, Storm Drains, and Sewers – This standard was discontinued in 2000 and replaced by ASTM C 1433

- ASTM C 1433 - Precast Reinforced Concrete Box Sections for Culverts, Storm Drains, and Sewers – This standard was adopted in 2000, replacing both ASTM C 850 and C 789. It covers single-cell precast reinforced concrete box sections for all depths of fill and is intended to be used for the construction of culverts and for the conveyance of storm water industrial wastes and sewage. Figure 1.1 displays the typical box sections for all fill heights indicating the required concrete cover over the reinforcement for all top and bottom slabs and walls. Figure 1.2 is an example table of the design requirements for a 6' x 6' precast concrete box section under earth, dead, and HS20 live load conditions. The tabular design in this specification were prepared according to AASHTO Standard Specification for Highway Bridges, 1997 Edition.

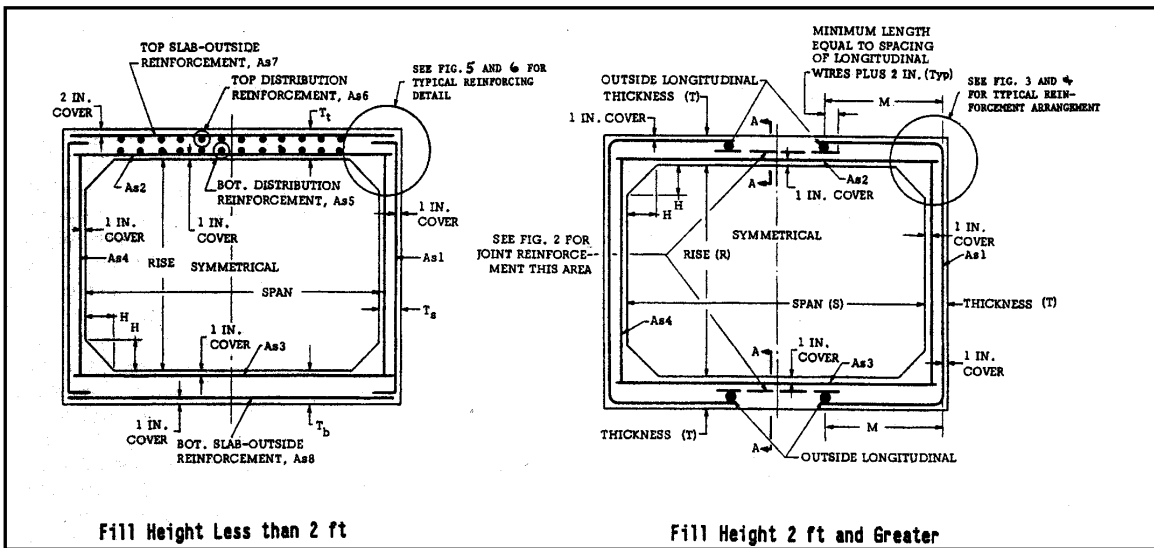

Figure 1.1: ASTM C 1433 Typical Box Sections

6 ft by 6 ft by 7 in.									
Design Earth Cover, ft	Circumferential Reinforcement Areas, in. ² /ft								"M," in.
	A _{s1}	A _{s2}	A _{s3}	A _{s4}	A _{s5}	A _{s6}	A _{s7}	A _{s8}	
0<2 ^A	0.19	0.57	0.31	0.17	0.25	0.19	0.19	0.17	18
2<3	0.21	0.48	0.36	0.17					18
3-5	0.17	0.25	0.23	0.17					18
10	0.17	0.22	0.24	0.17					18
15	0.17	0.31	0.32	0.17					18
20	0.19	0.39	0.41	0.17					18
25	0.23	0.48	0.49	0.17					18
30	0.28	0.58	0.61	0.17					18

^A Top slab 8 in.

Figure 1.2: ASTM C 1433 Design Requirements for a 6' x 6' Precast Box Culvert

1.3.2 Types of Precast Culverts

The following figures display the available types of precast box culverts.

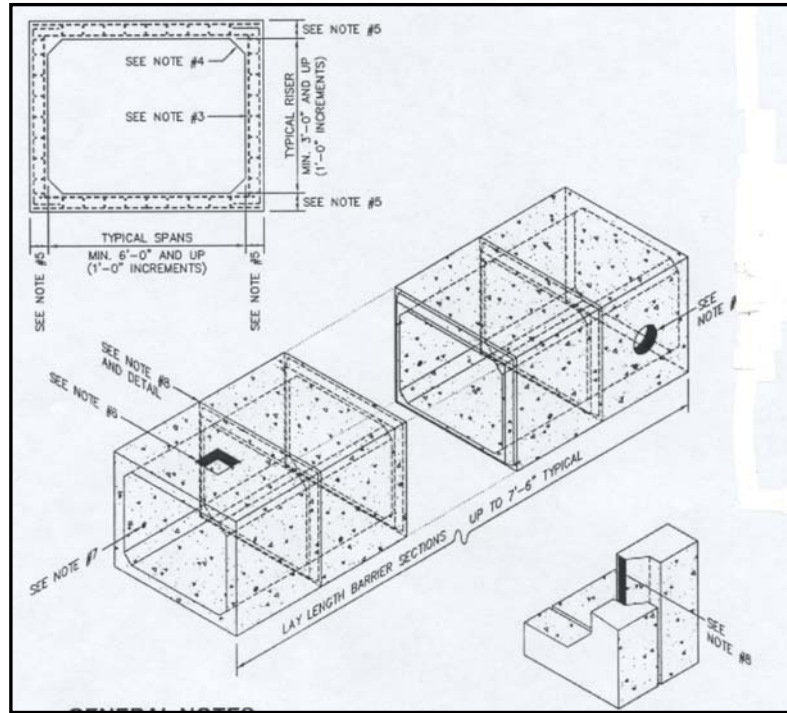

Figure 1.3: Single Cell Square/Rectangular Culvert

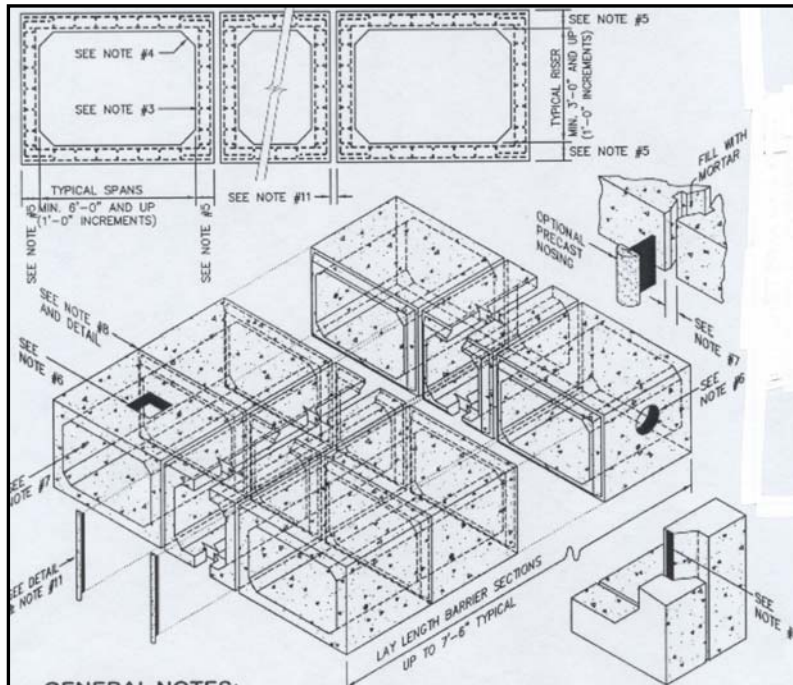

Figure 1.4: Multiple Cell Square/Rectangular Culvert

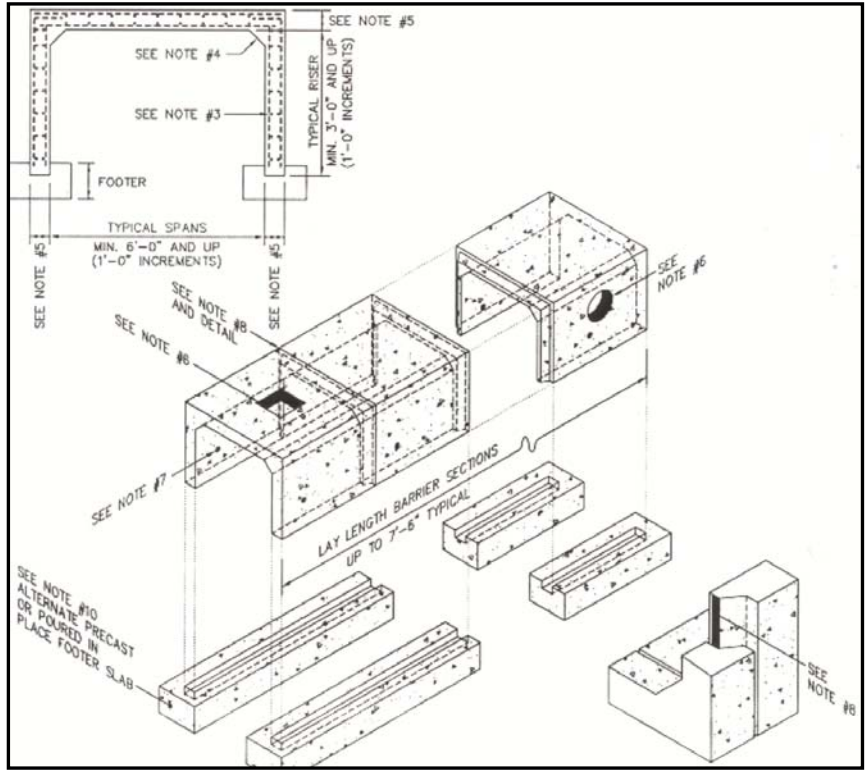

Figure 1.5: Three-sided Culvert with Footer Slabs and a Flat Top

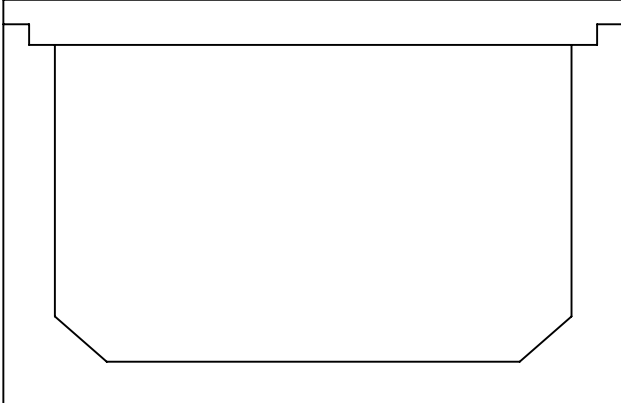

Figure 1.6: Three-sided U-shaped Culvert with a Flat Top Slab

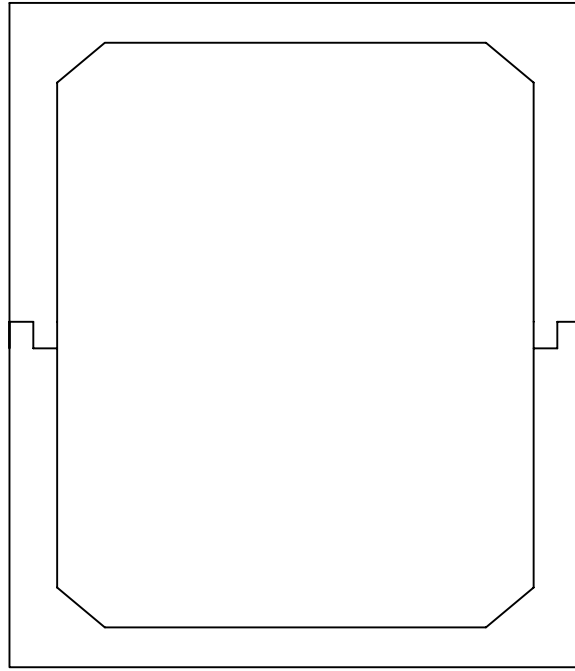

Figure 1.7: Two Three-sided U-shaped Culverts with a Mid-height Connection Joint



Figure 1.8: CON/SPAN Single Cell Precast Arch Culvert



Figure 1.9: CON/SPAN Double Cell Precast Arch Culvert

1.3.3 Standard Sizes and Available Options

The following summarizes the standard sizes and available options for both precast box culverts and CON/SPAN precast arch culverts.

Precast Box Culverts

Precast box culvert manufacturers have typical sizes. For 4-sided single cell box culverts: Spans range from 4'-12', rises range from 3'-12', and segments range from 4'-8' in length. For 3-sided U-shaped box culverts with a flat top: Spans range from 4'-12' and rises range from 1'-5'. For two 3-sided U-shaped box culverts: Spans range from 3'-12' and rises range from 6'-10'. U-shaped segments can be up to 14'-8" in length. Special designs are available with transportation being the only limitation on size. Slab and wall thickness varies depending upon the size of the culvert. The following are some options available from precast box culvert manufacturers:

- Water-tight joints
- Curved alignments
- Sloped faced ends
- Vee-Bottoms
- Skewed ends
- Keyed Ends
- Pipe openings
- Sump arrangements
- Weep Holes
- Post-tensioning
- Manhole openings
- Interior & Exterior Coatings
- Nose pieces (multi-section)
- Precast headwalls and wingwalls
- Energy Dissapators
- Precast concrete channels
- Rebar doweling in end section for attachment of field pour
- Butt ends

CON/SPAN Precast Arch Culverts

CON/SPAN precast arch culverts are available in clear spans ranging from 12-42' and rises ranging from 5-13'. For spans less than or equal to 24', the segment length is 8'; but, for spans greater than 24', the segment length is 6'. Precast wingwalls and headwalls are available as integral or separate pieces of the precast end sections. Precast footings or base slabs are available for a complete precast system. Figure 1.10 displays the different parts of a CON/SPAN arch culvert system. Because the arch culvert carries heavy loads at low stress levels, the CON/SPAN system can be used for many different applications:

- Bridge construction / replacement
- Railroad and airport overpasses
- Railroad and roadway underpasses
- Stream enclosures
- Pedestrian walkways
- Golf course / go cart / bikeway overpasses and underpasses
- Storm water retention systems
- Glycol retention / collection systems
- Underground vaults for protective storage
- Underground bunkers
- Utility tunnels
- Boat passages between lakes

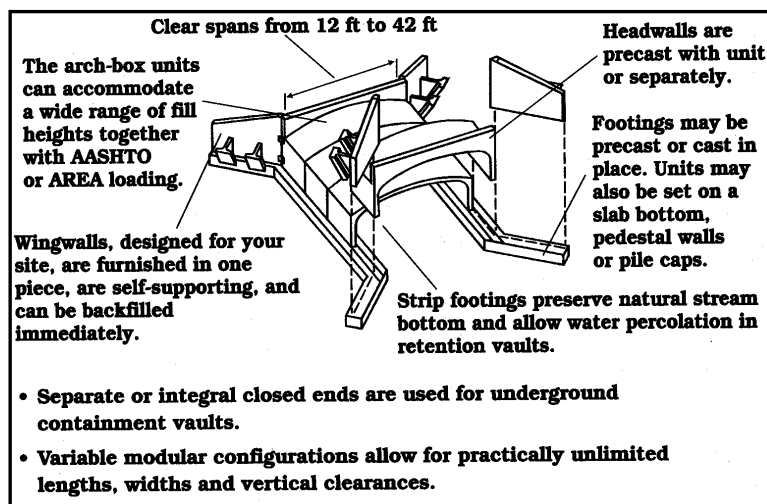

Figure 1.10: CON/SPAN Arch Culvert System Components

CHAPTER 2 LITERATURE REVIEW

2.1 General

An extensive literature review was conducted for articles pertaining to the construction and field performance of precast box culverts. Twelve articles were found that included information on this subject. These articles are listed in the Reference section at the end of this report.

2.2 Precast Box Culverts

The following provides a brief summary of the articles pertaining to precast box culverts.

Hill, et al (1995)

This article describes the performance of a double line of single cell precast box culverts installed in Wanamingo, Minnesota in 1974. The box sections have a span of 10', a rise of 9', and were designed for 16', 25' and 32' of fill above them. The wall thickness ranges from 8-11". All of the sections were installed in four days and the actual construction time for the project was four weeks. The boxes were placed 3' apart at the same low line elevation. The tongue and groove of the box sections was set at 6" and had an inside slope of 1/2" to help slide the sections together. Tie rods, 1" in diameter, were placed through tie holes at about mid-height to prevent culvert settlement and frost action from pulling the sections apart. The tie rods were also used on precast culvert end sections. Other design considerations included using riprap or concrete dropwalls to prevent piping and undermining of the culvert inlets and outlets and adding 4" chamfers to the concrete edges to improve the flow characteristics at the box culvert inlets.

The culverts were inspected at least semiannually for 10 years following installation. Some piping action was observed under the inlet end of one box culvert line. At low flow, some water disappeared under the inlet section and resurfaced about 16' downstream. A small horizontal hairline crack occurred about mid-height of the inside face of the vertical walls; however, no reinforcement steel was placed on the inside face

of the side walls. Slight hairline cracks appeared at the location where the sidewall met the 12” fillets; but, the cracks appeared to be the result of shrinkage and/or hauling stress. The cracks did not increase in size when installed and to this date remain unchanged.

After 20 years of service, the culvert sections were still functioning and in good shape; however, the following items were added to the design of precast box culverts to ensure a good quality structure: Minimum temperature steel was added in the side walls and No. 3 bars were added in the fillets to eliminate the cracking problem. Additional reinforcement was added in the top of the top slab and the bottom of the bottom slab to prevent potential hauling stresses. A standard thickness of 9” for the top slab, 10” for the bottom slab, and 8” for the sidewalls was adopted for the standard box culvert designs. A 24” wide filter cloth was to be installed on the top and sides of the culvert joints with mastic rope placed at the bottom, preventing sand infiltration through the joint, while allowing water to effectively move through the joint. Precast dropwalls were standardized at locations where they were required. And tongue and groove lengths were reduced from 6” to 4” to reduce cantilever reinforcement requirements and potential cracking.

Hurd (1991)

This article summarizes the results of a study conducted throughout Ohio to determine the extent to which durability problems existed in the external top slabs and joints between sections in precast box culverts. Out of the 256 precast box culverts installed in Ohio from 1979 to September 1988, 133 were inspected for the purpose of this study. Selection of the culverts was based on location, joint-surface treatment, and site conditions. The items observed during each site inspection were joint configuration, guardrail connections, joint gap, steel exposure, manufacturer, lift holes, guardrail bolt holes, joint leakage and corrosion, and condition of exposed top surface.

The following information related to joint leakage was noted in the article: There was a significant relationship seen between the severity of joint leakage and the type of joint wrap that was used: Significant joint leakage was prevented with the use of either a

total membrane waterproofing or an ASTM C 877 external joint wrap. In all cases where leakage was detected in culverts where joint wrap was utilized, leakage was observed in only 1-2 joints of out approximately 10 joints per culvert. Regardless of joint material, joint fit, and joint configuration, the research indicated that unwrapped joints sealed with a mastic or butyl joint material experienced leakage. But, joint leakage and corrosion were only observed on the top of the box and not on the sides. Additionally, there appeared to be no connection between the severity of joint leakage and the age of the culvert because of the small age range and the ineffectiveness of the internal joint materials in preventing leakage.

As a result of this study, the following recommendations for precast box culverts were devised: An external joint wrap should be required on the tops and sides of the joints; but, if full membrane waterproofing of the tops is provided, the wrap only needs to extend 1' down the sides. A surface sealer, either full membrane waterproofing or clear sealant, should be required on the external top slab and 1' down the sides, especially on culverts where the fill height is less than 3'. A minimum cover of 1/2" on the longitudinal and circumferential reinforcing steel should be required at the mating surfaces of the joints. Lift holes should not be permitted unless full membrane waterproofing is provided or an approved joint wrap is applied over the lift holes. No additional joint material should be placed in the insides of the joint on the top and the sides of the culvert. And, manufacturer's information should be placed within the top half of the inside of the culvert in order to easily identify the precasting company.

James (1984)

This article describes a study conducted to determine the behavior of precast box culverts designed using the ASTM C 850 specification without the use of shear connectors. The ASTM C 850 specification is a design standard for precast box culverts to be used with less than 2' of fill. For this experiment, two 7' by 5' reinforced concrete box sections were fabricated, assembled without shear connectors, and loaded with simulated service and ultimate wheel loads. The study compared the measured deflections and reinforcing steel strains with the predicted deflections and moments. The

results indicated that the ASTM C 850 design was conservative and that relative deflections in adjacent sections, without shear connectors, was insignificant at the design service wheel loads. The article recommended the use of precast box culverts without shear connectors.

Hicks (Spring 2001)

This article describes a double cell precast box culvert installation in Charlotte, North Carolina. Prior to installation, the neighborhood along Sedley Road had experienced problems associated with an open channel that passed through the area. The community believed that the open channel was an eye sore, a safety hazard for children, and a danger to the traveling public due to its periodic flooding; therefore, a recommendation was made to quickly and efficiently enclose the channel. The city responded by allocating funds for the design and construction of a new culvert system.

The final layout consisted of two lines of 8' by 5' precast box culverts that were 106' in length. In addition, the layout consisted of two horizontal bends in order to follow the existing drainage course, a box unit with a manhole opening to accommodate an existing storm drainage line, and additional wall steel in order to drill an equalization hole into the wall during the second phase of construction. Actual installation time was only one week and the precast option allowed the city to save nearly 20% in design and quality control costs. The project was a success due to the collaboration of the residents and city officials, the project speed resulting in minimal traffic disruptions, the cost savings, and the controlled production of the precast units.

Hicks, et al (Fall 2001)

This article describes the installation of a twin cell precast concrete box culvert near Raleigh, North Carolina. The culvert system was installed in a new golf and residential community to accommodate the increased wet-weather flows from the completed development. The structure measured 14' wide by 7' high and consisted of twin 7' by 7' cells: The double barrel was precast as one segment and there were a total of 22 twin segments in the 170' of length. A precast box culvert system was used

because the quick installation time reduced the construction time and the possibility of damaging the local natural environment. In addition, the soil at the culvert location was red acidic clay with a very low pH. Because pH plays an important role in determining the service life of a structure, the precast box culvert was a good option because its service life is twice as long as that of a corrugated metal pipe. Installation time of the twin cell precast box culvert was only one week.

2.3 Three-sided Precast Concrete Arch Culverts

The following provides a brief summary of the articles pertaining to three-sided precast concrete arch culverts.

Little, et al (1991)

This article describes a project conducted to evaluate the shear plates and grouted key joint performance of a three-sided precast box culvert. Prior to the experiment, the policy mandated the use of a grouted shear key joint with shear plates for three-sided precast box culvert installations with long spans (greater than 16') and shallow fill heights (0-2'). This project utilized an existing three-sided bridge structure located in Bloomfield Township, Michigan. The structure was 35' in length and consisted of seven-5' sections with a 30' span, a 7' rise, and a 30-degree left forward skew. The design loading used for the bridge was AASHTO HS20-44. Four test conditions were set-up combining grout and no grout with and without shear plates in order to measure their effects on deflection and load transfer.

The results of the tests were as follows: Both individually and combined, the shear plates and the grouted keyways transferred load across the joint; however, the grouted keyway alone provided complete load transfer where the shear plates alone provided minimal load transfer across the joint. Consequently, the tests showed that the grouted keyway alone was much more effective than the shear plates. Additionally, the difference between the grouted keyway alone and the grouted keyway with the shear plates was minimal. It was recommended that use of grouted keyway joints should be continued to protect pavement against cracking from differential deflections. But, the use

of shear plates at grouted keyways should only be considered for special end treatment to tie the end pieces to the body of the structure.

Hurd (1988)

This article describes how eliminating the shear connectors on all C850 box culvert joints is cutting the cost of precast box culverts in Ohio. Shear connectors are steel plates spaced 2 ½' apart and bolted to join adjacent culvert sections together. The use of shear connectors was prompted by FHWA and ODOT officials who were concerned that load transfers were not happening across the conventional tongue and groove pipe joint and the differential deflections between adjacent box sections induced by the live loads may result in damage to the culvert joints and overlaying pavement. But, these shear connectors seemed to be posing some problems to precast box culvert construction and installation. The shear connectors were difficult to install, they made the installation of the waterproofing membrane difficult, and they were very costly.

To see if the shear connectors were really needed, tests were conducted at the University of Toledo on a full-scale installation and a 1/6-scale model constructed as closely as possible to ASTM and ODOT requirements. The culverts were loaded up to 2 ½ times the AASHTO HS-20 design load plus impact and the strains and deflections were measured to determine the load transfer and differential deflections that occurred across the joints with and without shear connectors. The tests indicated that significant shear transfer was occurring across the joints without shear connectors, the differential deflections between the box sections were insignificant for the design loads, and the total deflections were much lower than the allowable limits for design loads in AASHTO. Consequently, the use of shear connectors in precast box culvert installations was discontinued.

Musser (1995)

This article summarizes the performance of three-sided precast box culverts from a Utah Department of Transportation Bridge Inspection Report. At the time, there were a total of 30 three-sided precast box culverts located in the UDOT bridge inventory, and

83% were located on county roads. Of all the negative findings related to the report, the highest percentage (53%) was related to water leakage through joints: It appears that water was seeping through joints and tension cracks. One joint detail indicated the presence of a grout key and metal straps between the precast sections. Industry practice typically provides a grout key for the flat top boxes and butt joints for the rounded boxes; and, depending upon the project specifications, waterproofing mastic may or may not be utilized. Recent research has eliminated the need for metal straps between sections. Other negative results came from manufacturing and/or installation deficiencies, erosion, and scour.

At the time, it was discovered that neither AASHTO nor ASTM design specifications included provisions for these three-sided “bridges.” There seemed to be no standard means of assessing their material, manufacturing, or construction quality. Through this synthesis, it was recommended that UDOT’s product approval be restricted to project specific applications of these products because there were no nationally recognized standards for these products, verification of industry based design procedures was very sparse, and a site specific systems approach for their design should have been mandatory because these structures are employed as bridges.

Carfagno, et al (1997)

This article describes the installation of a double cell arch culvert in a major intersection in Prairie Village, Kansas. It was determined that the existing concrete box culvert located under the intersection was inadequate because flooding was occasionally closing the major juncture. In order to solve this problem, two alternatives were proposed: A triple precast box culvert (12’ x 10’) and a double cell precast three-sided arch culvert (20’ x 7’). The double cell precast concrete arch culvert was chosen by the city because of its aesthetic appeal, lower maintenance costs, and fewer units reducing the fabrication and erection time. And, there was also less potential for debris blockage at the entrance to the culvert. The design load for this project was AASHTO HS20-44 and 1’ of fill was placed on top of the units.

Overall design, community involvement, and good communication made this project a complete success. The design allowed the use of few units to fabricate and install, precast footings to minimize traffic impact, and flowable fill to speed construction and reduce the possibility of backfill settlement. In addition, the consulting engineer and contractor worked together with the community allowing an open line of communication during the construction of this intersection. The residents agreed to allow construction to continue 24 hours a day while the intersection was closed in order to minimize the road closure to just 7 days, half of the time allowed by the contract.

Hill (1985)

This article describes the construction and field evaluation of nine precast concrete arch structures built and installed in Minnesota from 1981-1983. The article includes culvert locations, individual data, fabrication and material specifications, field installation, follow-up inspections and recommended requirements for the successful placement of a precast arch structure. As for the joints between the adjacent sections of these arched structures, a mastic rope was hammered into the joints to fill the opening and a geotextile fabric was placed over the mastic and joint to allow moisture to seep through the joint but to prevent the soil from entering the joints. This joint method seemed to work satisfactorily for all mentioned installations.

The results of this study indicated that movement and settlement of the structures were within their given tolerances. Cracking at the vertex area of arch sections occurred, but the widths were less than the generally accepted maximum allowable crack width of 0.01". And although scour of the footings was possible, it was prevented by using filter material and appropriately sized rock riprap. Finally, use of these designs was restrained because the FHWA required competitive alternatives when a proprietary structure like the precast three-sided arch culvert was used, thus requiring designers to submit alternates for each site in which an arch structure was selected.

Beach and McGrath, et al (1988, 1996)

These articles describe a study conducted to determine the correlation between the field performance of a precast concrete arch culvert and the finite element analysis program, CANDE. The evaluation compared the computer model's deflection and crack behavior output and the actual field test data to determine the validity of the program. The experiment involved installing three 8' laying length culverts on a cast-in-place slab, backfilling, and applying external loads as much as five-times greater than the HS20 design service loading without impact to measure associated deflections and cracks. After the tests were complete, actual section properties of the test unit were determined and used as input for the CANDE computer analysis. A resulting graph indicated that the comparative values of deflection were in good correlation. Additionally, it was discovered that the precast concrete arch culvert greatly exceeds all performance requirements for highway loading by sustaining a load greater than five times the HS20 design load without impact through succeeding deformations imposed by the loading jack.

2.4 Summary

The articles pertaining to be both precast box culverts and three-sided precast concrete arch culverts can be summarized as follows:

- Precast culverts have a quick installation time, reducing environmental and traffic impact.
- The inspected precast culverts are currently in good working condition and no major failures have been recorded.
- Joint leakage seems to be the most predominant problem associated with precast culverts.
- A filter fabric wrap should be required on the tops and sides of the joints to prevent soil infiltration into the culvert.
- Scour of the culvert inlets and outlets can be prevented with the use of filter material and appropriately sized rock riprap.
- The ASTM C 850 design is conservative and relative deflections in adjacent sections, without shear connectors, is insignificant at the design service wheel loads.

- In three-sided precast concrete arch culvert installations, significant load is transferred across a grouted keyway joint in the absence of shear connectors.
- The field performance of precast concrete arch culverts correlates with the CANDE finite element analysis program.
- As concluded in Beach 1988, the precast concrete arch culvert greatly exceeds all performance requirements for highway loading by sustaining a load greater than five times the HS20 design load without impact.

CHAPTER 3 FLORIDA SITE VISITS

3.1 General

Site trips were scheduled in order to observe some previous precast box culvert installations and tour a precast manufacturing plant. The following describes the results of the site visits taken.

3.2 Tallahassee Trip

A trip was taken on November 26, 2001 to Tallahassee, FL to observe some previously installed precast box culverts. The following describes the three culverts that were visited.

3.2.1 Intersection of Lake Bradford Rd. and Epps Dr.

Figures 3.1 and 3.2 show either side of a single cell precast box culvert unit manufactured by Hanson. The end sections and end components are cast-in-place. At the time of the site visit, this culvert was a little less than one year old and it was in good condition with no major problems observed.

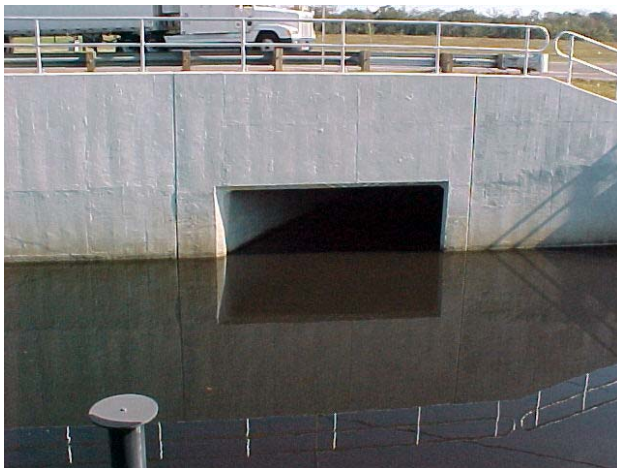

Figure 3.1: Exterior View of Culvert



Figure 3.2: Exterior View of Culvert

3.2.2 Near FSU Track Stadium

Figures 3.3 and 3.4 show the interior of a double line of two U-shaped sections placed one on top of the other. At the time of the site visit, the culverts were approximately 4 years old and in fair condition. The RAM-NEK®, or preformed plastic joint material, used in between each section was coming apart and some was missing in areas where it should have been. Please refer to www.ramnek.com/company_profile.htm for more information on RAM-NEK® joint material. There were spots above the culvert in which the filter fabric membrane was exposed displaying infiltration problems. On a number of occasions the contractor had to revisit the site and fill these “sinkholes” above the culvert with new earth. It was suggested that maybe a two-ply membrane should be used to further prevent the infiltration of material into the culvert. Additionally, Figure 3.5 displays some exposed and corroded sections of reinforcing steel that appears to have very little if any concrete cover. This may have resulted from the steel being in contact with the interior form during construction, inhibiting the concrete from forming correctly over the steel.

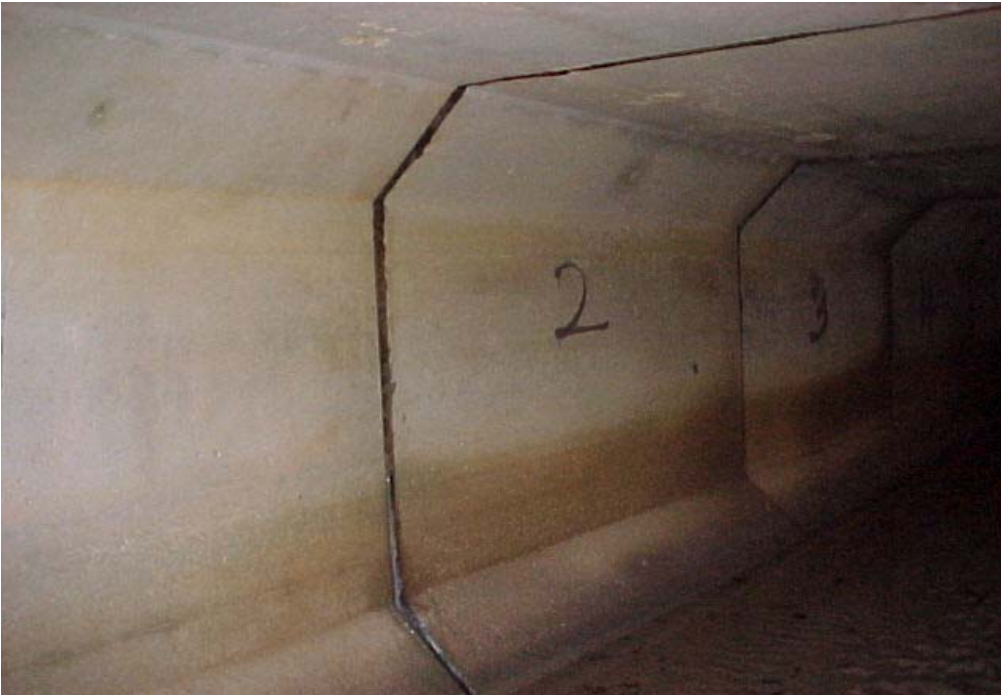

Figure 3.3: Interior View of Culvert Sections



Figure 3.4: Joint Between Culvert Sections



Figure 3.5: Exposed and Corroded Reinforcing Steel

3.2.3 Intersection of Thomasville Rd. and Velda Dairy Rd.

Figures 3.6 and 3.7 show the interior of a single cell U-shaped with a flat slab top. At the time of the site visit the culvert was approximately 2 years old and in fair condition. The absence of some joint material, corrosion and cracking were observed.



Figure 3.6: Interior View of Culvert



Figure 3.7: Interior View of Joint

3.2.4 Contractor's Opinion

Fred White of J. R. Jones Construction prefers the U-shaped sections over the square box sections because they are easier to set and level and the 1' of gravel beneath the boxes does not get disturbed during the installation process. The larger U-shaped sections weigh the same as the shorter single cell box sections; therefore, there may be an overall reduction in the total number of joints associated with the installation. This may result in quicker installation time and fewer leakage points. When connecting two U-shaped sections, White uses RAM-NEK® material in between top and bottom pieces and a tongue and groove joint between each 12' section. The tongue and groove joints make it harder to pull out the boxes and there are less installation problems because the sections lock together without having to pull the sections together. When pulling two sections together with a "tugger" to get a tight fit, the bedding gravel will more than likely be disturbed causing the foundation to become uneven. When using multiple cell units, it is good to grout between the lengths of the boxes in order to connect the units and align the boxes in case they are constructed a little bit out of line. White also believes that it is

cheaper to use precast when there is a bad water situation. But because the FDOT has strict regulations for precast box culverts and transportation of the larger, heavier sections can complicate things, it is sometimes easier to use cast-in-place box culverts when applicable.

3.3 Hanson Precast Plant Tour

A trip was taken on February 12, 2002 to Green Cove Springs, FL to tour a Hanson Precast Plant. The Hanson plant currently only uses the wet casting method for precast box culvert construction. In the wet casting method, the form is properly constructed and assembled, the concrete is pumped into the forms, and the section is set aside in the forms to cure for at least 4 hours. When there is a precast job underway, the Hanson plant manufactures two precast box culvert sections per day. One section is poured in the morning. While that section is curing, the precasters work to assemble another set of forms. After lunch, the second section is poured while the first section is being disassembled and then reassembled for the start of the next day. Figure 3.8 shows the wire reinforcement and interior form of a precast box culvert waiting for the exterior form shown in Figure 3.9 to be lifted and assembled around the reinforcement. A precaster was preparing a section of the form for its next section pour. Figure 3.10 displays a series of adjacent 10' x 5' precast box culvert sections waiting to be delivered to their project. Figure 3.11 is a cross sectional view of a single cell precast box culvert in the precast yard. Figure 3.12 is a side elevation view of the tongue and groove joint detail. Figures 3.13 & 3.14 are Hanson drawings displaying a typical joint detail and a typical joint cross section indicating the RAM-NEK® locations.



Figure 3.8: Interior Form



Figure 3.9: Exterior Form



Figure 3.10: Series of 10' x 5' Precast Box Culvert Sections



Figure 3.11: Single Cell Precast Box Culvert



Figure 3.12: Tongue and Groove Joint

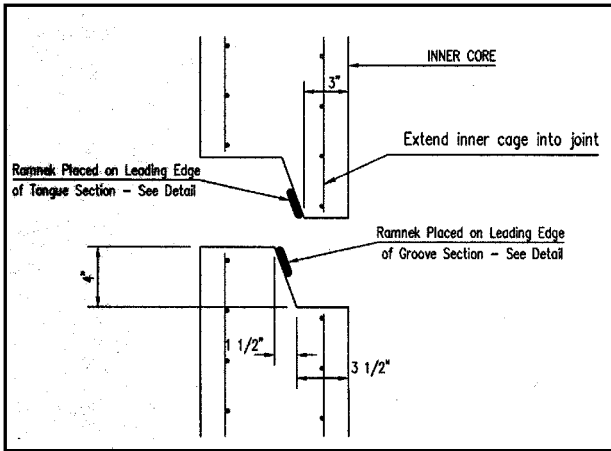

Figure 3.13: Typical Joint Detail

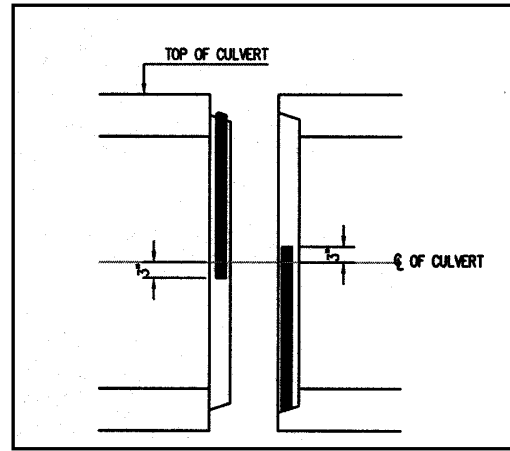

Figure 3.14: Joint Cross Section

3.4 Summary

The three precast box culverts that were inspected in Tallahassee all appeared to be in average working condition. Some problems encountered involve exposed and corroded reinforcing steel, the absence of essential joint filler, RAM-NEK®, material, and sinkhole developments over the precast structure where overlaying earth has seeped through the joints of the culvert sections.

CHAPTER 4 RESULTS OF FLORIDA SURVEY

4.1 General

The following summarizes the survey responses received from each FDOT District, a list of shop drawing review questions, a review of the current FDOT specifications for three-sided precast culverts and precast concrete box culverts, and a review summary.

4.2 District Survey

A survey was sent to each district in the state of Florida to identify the usage and performance of precast box culvert systems around the state. Appendix A is a contact list of all the FDOT Districts and Appendix B is a matrix of the survey responses. Each district is summarized on the following pages.

District 1

District 1 has been using precast box culverts for approximately 10-12 years. About 10% of new box culvert installations and 2% of the extensions to existing cast-in-place culverts are precast. Cast-in-place box culverts are specified in the plans, but the contractor has the option to use precast. Single and double cell units are installed and all of the end components are cast-in-place. The wingwalls are all mechanically connected. There have been no problems nor known failures associated with precast box culverts; and, they are believed to be a good product if constructed properly.

District 2

District 2's first precast box culvert was installed in 1993. Since then, a total of 9 out of 255 box culverts installed in District 2 have been precast. All of these culverts are considered 'bridge' culverts consisting of multiple cell units measuring greater than 20' wide. There have also been two precast box culverts installed as extensions onto existing cast-in-place box culverts. Because District 2 only keeps an inventory of 'bridge' culverts spanning greater than 20' wide, there is no count of the number of 'non-bridge'

culverts in the District. Usually the plans detail cast-in-place box culverts; but, the contractor is given the option to substitute precast as per the FDOT Standard Specifications. As for the end components, cast-in-place is believed to be more practical than precast. The District maintenance group would prefer to see stand alone wingwalls because they would be easier to repair if and when there is a failure. Mechanical connectors are more likely to have future maintenance problems due to corrosion.

District 2 believes that a good design takes into consideration all of the site specific information pertaining to the culvert, such as the soil and hydraulic conditions. District 2 would like to see the state of Florida come up with some design “example details” as opposed to “standard details” in order to allow the designer the option to choose the details that best fit their specific site. There is concern that a standard detail would be looked upon as a “one size fits all” detail when in fact it may not be applicable for all sites. For example, how deep the toewalls should extend below the box culvert's floor at each end of the culvert to prevent undermining will depend on the soil and hydraulic conditions at the location; consequently, the depth cannot be standardized.

Precast box culverts may not be opted for more often by contractors because of the cost factor associated with precast. Contractors are required at their expense to hire a specialty engineer to submit a design for the Department’s approval; therefore, cutting into the contractor’s savings. In addition, the cast-in-place box culvert computer design program is readily available and easy to use. The designer’s main concern is the possible joint leakage associated with precast box culverts. But, because the precast box culverts are all relatively new, there have been no associated problems or failures thus far. Because the joints are the weakest link of the precast culvert, failure would more than likely occur at the joints. The shorter construction time would be the definite advantage of precast over the cast-in-place box culverts. Perhaps if the popularity of precast box culverts increases, suppliers may start to stockpile the “standard” sizes and keep the costs low.

District 3

District 3 is unsure how long precast box culverts have been used. About 95% of the box culverts are detailed as cast-in-place on the plans; however, the contractor opts to use precast roughly 10-20% of that time. On occasion, approximately 5% of the time, the District details precast in the plans due to the project's impact on the traveling public. The District is unsure as to why precast is not opted for more often. It may be because Section 410 was added to the Specifications only about 5 years ago, a lack of knowledge by the designers, or a lack of standard details. The end components are all cast-in-place and tied into the precast units. The wingwalls are believed to all be attached without any known failures. District 3 would like to see a standard precast detail similar to that of the cast-in-place box culvert with a computer program to design the cross section. District 3 does not know of any failures; but, the possibility of failure is always a concern. It was suggested that the sections be post-tensioned together after installation in order to avoid the possibility of failure.

District 4

Precast box culverts have been around for about 20 years, but use has really increased in the past 6-7 years. Cast-in-place is always specified in the plans, but the contractor can propose a precast alternative. Precast is opted for in approximately 95-99% of the new installations and 75% in the extensions to existing cast-in-place structures. The precast box culvert types include the square and rectangular single cell units, installed singly or placed next to each other to form a multiple unit design. Precast is used for almost all wingwall components. And although there was a recent failure involving a stand alone wingwall, wingwalls are not required to be mechanically attached to the precast box section. However, any slight movement of the wingwall could cause infiltration and failure. Headwalls and toewalls can be either cast-in-place or precast; however, it may be better if the toewalls are cast-in-place due to transportation and installation concerns. Precast box culverts are advantageous due to their quick installation time reducing the overall construction time. Good details prepared by the precaster indicate a geotechnical filter fabric, pick-up points, compressed joint material, pipe openings, and good connection details between the headwall/toewall and the precast

box sections. District 4 would like to see a Florida standard for precast box culvert installations. The standard should eliminate the need for a box culvert design in over 60% of all the culvert installations and normalize installation procedures to provide a product of quality and durability.

In the past, box culverts were generally never inspected. However, District 4 now mandates the inspection of any existing box culvert that requires an extension to ensure that the box is still in good working order. This came about because a cast-in-place box culvert was found to be in very bad shape just as an extension was to be installed, causing the project to become delayed while the existing box sections were being restored. In all other cases, box culverts are not periodically inspected because they are usually filled with water and there are no visible signs of piping failures, potholes, etc. There does not seem to be any concern about failure due to the number of joints in a precast box culvert installation because cast-in-place box culverts seem to have just as many joints. Therefore, the possibility of failure, whether it be precast or cast-in-place, lies with proper installation of the structure.

District 5

District 5 has been using precast box culverts since 1991. Cast-in-place is specified and the contractor has the option to submit a precast proposal; however, there have been no precast box culvert proposals in the past two years. Aside from the single cell square box culvert, District 5 had one project where three single cell units were installed side-by-side to create a triple barrel culvert. But, there was concern with the longitudinal joints between the cells because fines were getting trapped in the joints and flowable fill needed to be poured between the cells. As for the end components, the headwalls are usually cast-in-place and the District is not aware of any wingwalls being precast. There is always the possibility that if the wingwalls were not connected to the barrel, the walls could fail during construction due to hydrostatic pressure. There was a wingwall failure a few years ago, but it was unrelated to the precast box culvert. The contractor may opt to stay away from precast because the precaster must hire a specialty engineer to design the cast-in-place end components at an additional cost.

District 5 is under the impression that precast box culverts are not structurally equivalent to the cast-in-place box culvert; and, there are concerns about joint leakage. There are no requirements on joint tightness in the FDOT specification and the ASTM is not being enforced by the inspectors. Sometimes the side walls are not straight and the segments are not cast to match. This results in segments that do not fit well together making it difficult to align the segments and maintain straightness. However, the precast units can be constructed relatively quickly and the contractor can save construction time because precast eliminates the need for formwork, steel, and concrete delivery. District 5 would like to see the state of Florida develop a precast box culvert standard if the water-tightness and settlement issues and the difference between the ASTM standards and the FDOT's design requirements are resolved. The standard should include a provision for future extensions to existing culverts because the connection detail between the existing cast-in-place structure the new precast extension is very important.

District 6

District 6 does not use precast box culverts. Cast-in-place is always specified; however, the contractor can propose a precast alternative and it will be evaluated by the District. All end components are also cast-in-place. Cast-in-place is believed to be a better product because it is more compliant for alignments that contain geometric inflections and extensions to existing cast-in-place culverts. The discontinuity of the precast box culvert is critical when dealing with differential settlement, and the strength of the joints is critical for maintaining the correct alignment of the structure. District 6 believes that a precast box culvert standard could be used for straight alignments. A precast box culvert standard should provide flexibility of sections under different loading conditions.

District 7

District 7 built their first precast box culvert around 1994. Although cast-in-place concrete box culverts are always specified and detailed in the plans, the contractor is given the option to provide a precast alternative and must submit shop drawings for approval. It is estimated that 75% of all new installations and less than 50% of the

extensions are constructed as precast. The types of precast box culverts include four-sided square and rectangular single cell culverts installed as a lone unit or placed side-by-side to form a multiple cell unit. Wingwalls, headwalls, and toewalls are generally cast-in-place and all wingwalls are mechanically attached to the precast barrel section.

District 7 indicated some advantages and disadvantages of precast box culverts. They are cast under shop conditions which allows for better control of the finished product; and, job site construction is much quicker, thus reducing the lane closure time. However, additional work may be needed to maintain and ensure the integrity of these structures. Additionally, there have been some installation problems with joints that do not mate correctly, damaged units, and insufficient concrete cover over the reinforcement. And, contractors have submitted shop drawings with insufficient details, particularly concerning the cast-in-place wingwalls and headwalls components, bends in the system, and tie-ins to existing structures.

District 7 would like to see the FDOT develop standard details for precast box culverts. The plans should fully detail the barrels and any cast-in-place components and provide joint dimensions and protection requirements. The plans should be sufficient as to minimize or eliminate the need for shop drawings during construction. At the present time, District 7 is not aware of any major failures; but, there have been instances where joint gasket material has separated from the joints. There is concern about the long term effect of the large number of joints and the possible loss of fill material through the joints if the boxes are not fabricated and installed properly.

4.3 Shop Drawing Review Questions

The following questions are a summary of the things each District looks for when reviewing precast box culvert details designed by a precaster.

- Does the design meet the loading criteria and AASHTO/FDOT requirements?
- Is the precast submittal equivalent to the cast-in-place in reinforcing and dimensions?
- Do the hydraulic opening sizes match the original plan?

- Is the concrete class adequate?
- Is the concrete mix adequate?
- Is the wall/slab thickness adequate?
- Is the reinforcement cover adequate?
- Is the reinforcement equal to or greater than the reinforcement called for in the original plans?
- Are the joints completely detailed (including joint sealers and filter fabric)?
- Is there epoxy on each face of segments to create water-tightness and is there adequate wrapping with the filter fabric?
- Are the openings for pipes, inlets, etc. shown and detailed?
- Are the cast-in-place components fully detailed?
- Are the bedding preparation adequate?
- How is the constructability?
- Are the plans and calculations signed and sealed by a Florida PE?

4.4 Summary of current FDOT Specifications

The Florida Department of Transportation currently maintains a standard specification for Three-Sided Precast Culverts (Section 407) and Precast Concrete Box Culverts (Section 410).

4.4.1 Section 407: Three-Sided Precast Culverts

Three-sided precast culverts should not be used at locations with an Extremely or Moderately Aggressive Environmental classification nor to extend the inlets of existing multi-cell culverts due to potential clogging of debris. The design should comply with the requirements of the AASHTO Standard Specifications for Highway Bridges and the Structures Design Guidelines. Design requirements should include a design load of HS-25, a hydraulic analysis, and a scour evaluation. The channel should be lined with either a 6" cast-in-place reinforced concrete slab with a 30" deep toewall at the inlet and outlet end of the structure or a blanket of 18" riprap. A lining, extending 10' beyond the ends of the structure, should be used to withstand the hydraulic forces. The bottom of the spread footing should be 30" below the bottom of the channel lining.

The precast units should be produced with keyways at the adjoining surfaces or butt joints between the adjacent units. An approved non-shrink grout should be used in the keyways. All joints between precast units shall be sealed with a bituminous seal and covered with a 24" strip of filter fabric adhered to the precast unit. Care should be taken not to damage the filter fabric during backfill operations. When backfilling immediately adjacent to each side of the structure, use a mechanical tamper or approved compacting equipment. The Contractor may use an alternate low modulus silicone joint sealant if approved on the shop drawings. All handling devices should be removed and all holes filled with non-shrink grout after erection of the precast unit. The interior of all units should be clearly marked indicating span, rise, skew, date of manufacture, name of manufacturer, and design earth cover. Footings shall be constructed of precast or cast-in-place concrete. If precast footings are used, prepare a 4" thick layer of compacted granular material to a minimum width of 12" outside the footing width. A 3" deep key shall be formed in the top surface of the footing, 4" wider than the wall thickness.

4.4.2 Section 410: Precast Concrete Box Culverts

Precast concrete box culverts shall meet the requirements of AASHTO M 259 for installation with less than 2' of cover and AASHTO M 273 for installations with greater than 2' of cover. In lieu of a redesign, design the precast box culvert section identical to plan details. When using headwalls and other special features, provide special precast end sections with exposed reinforcement for tying the headwall reinforcing steel. The bedding shall consist of a 6" coarse concrete sand or other suitable granular material placed directly below the culvert, extending 12" on both sides of the culvert. The field joints shall be made with a butyl rubber based preformed plastic gasket material or as detailed in the plans. The gasket material shall be of such a size to create a watertight seal. The outside of each joint shall be completely wrapped with a 24" woven or non-woven filter fabric. The fabric shall be tightly secured against the box culvert section with temporary metal strapping to be removed after section has been sufficiently backfilled. The headwalls and other special features shall be constructed in place leaving a sufficient length of steel exposed for connection to endwalls or other cast-in-place sections.

4.5 Summary

Although the concept of precast box culverts has been around for the past 20 years, most of the Districts in Florida have only been using precast for the past 6-12 years. Because precast usage around the state does seem to vary quite a bit, Table 4.1 indicates the percentage of precast box culvert used in each District. The main advantage of precast over cast-in-place box culverts is the quick installation time reducing the overall construction time. But, there are problems with joints that do not mate properly, sections that are damaged, and insufficient reinforcement cover. In addition, there is no requirement on joint tightness in the specification and District 5 states that the ASTM requirements are not enforced by the inspectors. Districts 1, 2, 3, and 4 do not indicate any problems thus far with precast box culverts. Most Districts detail the box culverts as cast-in-place on the plans and allow the contractor to opt for precast. District 3 details precast in the plans approximately 5% of the time mostly when the project impacts the traveling public.

Table 4.1: Percentage of Precast Box Culverts in Florida

District	Frequency of use for new installations	Frequency of use for extensions
1	About 10% precast	About 2% precast
2	9 out of 255 (3.5%) precast bridges	2 precast extensions
3	About 10-20%	About 10-20%
4	About 95-99% precast	About 75%
5	0% for the past two years	0% for the past two years
6	0%	0%
7	About 75%	Less than 50%

Precast box culverts types used by all Districts are square and rectangular single and multiple cell box units. No Districts indicated any use of the three-sided precast arch culverts; however, it is believed that some may have been installed around the state of Florida. All except District 4 deal with cast-in-place end components. District 4 seems to mostly use precast wingwalls. The toewalls and headwalls are either precast or cast-

in-place. Most Districts would like to see all wingwalls mechanically attached to the barrel, or box section, as opposed to being stand alone due to possible wingwall failures. There have not been any major failures of precast box culverts and none of the Districts seem too worried about the possibility of failure due to the discontinuity and the shear number of joints involved in a precast installation. But, District 3 suggests that the precast sections be post-tensioned together after installation. All of the Districts seem positive about the possibility of a precast box culvert standard in the state of Florida. The standards would be helpful to the contractors and reduce or eliminate the need for shop drawing reviews.

CHAPTER 5 RESULTS OF THE STATE SURVEY

5.1 General

The following summarizes the survey responses received from each state, a list of problems and solutions encountered by each state, a summary of the state surveys and a summary of the state specifications and details.

5.2 State Survey

A survey was sent to each state in the continental United States to identify the usage and performance of precast box culvert systems around the country. Appendix C is a contact list of all states. Approximately half of the states responded to the inquiry by answering questions and sending specifications and detailed drawings. Appendix D and E are matrices of the state survey responses and specifications. Each state is summarized on the following pages.

Arizona

Arizona uses CON/SPAN Bridge Systems. Please refer to Chapter 1 for an overview of CON/SPAN Bridge Systems or to the Pennsylvania section on pages 49 & 50 for more information on CON/SPAN's details and specifications.

Colorado

Colorado has allowed precast as a substitute for the traditional cast-in-place box culverts for the past ten years. Approximately 10% of all new culvert installations are either square or rectangular precast units. The Colorado DOT states that construction time limits encourage the use of precast. But, there is concern about control over what is designed or what is installed in the field, as well as a lack of knowledge of what is possible, available and the appropriate design methods. There have been occasional times when fit-up between sections has allowed soil to infiltrate through the joints and cause settlement of the overlaying pavement. This was corrected by visiting the fabrication plants and making necessary adjustments and by modifying the policy to require every joint to be wrapped with geotechnical fabric.

Delaware

Delaware has used CON/SPAN on some of their recent design-build projects. And although they are not aware of any problems to date, they believe that CON/SPAN was not very flexible with their design when asked to make some changes. In addition, Delaware installed a Bebo arch approximately eleven years ago and it remains in good condition.

Georgia

Georgia has had a precast box culvert standard since 1985; however, 99% of all of their culverts are constructed as cast-in-place structures. Because the decision is left to the contractors, the Georgia DOT does not know why the precast option is not being utilized more often. Most precast box culverts are square, but, the GDOT is aware of a number of companies that supply arched culverts. The arched culverts appear to be more difficult to use because it must be founded in such a manner that it does not scour out in a flood. At this time, the GDOT is unaware of any particular problems with precast and no future problems are foreseen as long as the culverts are installed correctly.

Illinois

Precast box culverts have been used on a regular basis in Illinois since the early 1980's. In 2001, Illinois spent approximately \$5.3 million on cast-in-place box culverts and \$6.2 million on precast box culverts. Many types of precast box culvert systems are used; but, the majority of the installations consist of single and multiple cell square or rectangular units. The multiple cell boxes consist of single cell units placed side-by-side with a nominal 3" of concrete placed between them. In addition, Illinois also installs three-sided precast structures with no bottom slab, similar to CON/SPAN, where each section may span up to 28'-42' in length.

The IDOT encourages its District offices to specify precast as opposed to cast-in-place concrete whenever possible; however, precast is not always an applicable option due to certain geometric configurations. In addition, Illinois does not recommend utilizing precast in areas that are subject to flooding with highly scourable flow lines, in

areas with excessive settlement, in high seismic zone regions, and in areas where “imperfect trench” or pile foundations are required. For Illinois, cast-in-place end sections are usually detailed on the plans; however, contractors may elect to build end sections using precast only if additional steel is included for handling stresses. Typically, precast end sections work well with routine projects that have very little skew.

Illinois’ geometric limitations associated with precast box culverts include a maximum skew angle of 60 degrees, a maximum cell span and rise of 12’, and a minimum cover of 6”, measured at the edge of the shoulder. Any cast-in-place attachments must be collared around the end of the precast section. A 6” layer of porous material shall be placed below the elevation of the bottom of the box, extending at least 2’ beyond each side of the box. The joints between each section shall be sealed with a mastic joint sealer. And, the joints shall be externally sealed on all four sides with a 13” external sealing band or 24” non-woven geotechnical fabric to stay in place during backfill operations. The concrete cover for all reinforcement follows the ASTM C 1433 requirements indicated in Figure 1.1 of Chapter 1.

Illinois’ biggest concern with precast box culverts is the fit-up between each section: An incorrect fit-up may leave an intolerable gap between adjacent sections which can allow soil to penetrate through the joints causing settlement of the pavement above. After experiencing this problem, Illinois visited fabrication plants in order to identify necessary adjustments in their process. About three years ago, Illinois also modified their specification to require that every joint be wrapped with geotechnical fabric in addition to the mastic. By changing the policy and enforcing better fabrication, Illinois was ultimately effective in providing good joints to prevent soil infiltration. One District insists on casting small holes in the mid-height of the walls, bolting an I-hook through each hole, and using a threaded bar from I-hook to I-hook of adjacent sections to come-a-long the sections together. However, they insist on leaving the threaded bars in place. Although this can be done, Illinois has had good success without taking this extra measure.

Due to their continued widespread use, Illinois DOT personnel are feeling more confident with the service life, reliability, and maintenance of these precast box culverts. In addition, precast box culverts shorten construction time in the field allowing minimal traffic disruptions, and precast fabrication is completed with experienced labor in conditions not affected by the weather. Although precast box culverts are currently believed to be a viable product by the state of Illinois, good communication with the fabricators and periodic inspections of the plant are very important. And, Illinois has recently moved toward a QC/QA program in hopes that the quality of their precast box culverts remains good.

Kansas

Kansas created a traditional cast-in-place culvert standard in 1957; but, they have allowed the option of precast since the late 1970's. Approximately 10% of all box culverts are precast; however, this only includes 10' and wider structures that are tracked on the State System. There is no feedback on the smaller State culverts or the City and County culverts. Typically, Kansas uses single and double cell precast units with 8-10' spans; but, the maximum size of a precast box is determined by what the contractor can physically pick-up and place in the field. For double cell installation, a joint gap of 1" shall be left between the boxes. Box culverts are always designed as a cast-in-place structures; however, unless otherwise noted, the contractor has the option of submitting plans for a precast alternative. Flared wingwalls are required to be cast-in-place with a special cast-in-place section for transition from the precast sections; however, straight wingwalls are allowed to be precast without a cast-in-place transition section. Depending upon the height, the KDOT may require the headwalls and wingwalls to be cast-in-place. This may be why many contractors do not opt to use precast. Most of the time precast is used only when time is the biggest concern on the project.

Currently, Kansas maintains standard specifications and a few miscellaneous details pertaining to precast box culverts. Kansas requires either a 6" crushed stone or 3" concrete seal course foundation. A distribution slab is required for fill heights less than 2'. A cast-in-place distribution slab is defined as a 6" thick slab with #13 bars at 18"

transversely and #15 bars at 12" longitudinally. The substitution of a welded wire fabric (WWF) is acceptable. If the fill height is greater than 1', the distribution slab may be constructed of precast with the same reinforcement. The joints should be centered over the box sections and 3" of granular fill should be provided between the box and the precast distribution slab. Clearances to reinforcing steel shall be a minimum of 1 1/3" from all faces. However, when the depth of fill is less than 2', the clearance to reinforcing steel in the top slab shall be 2 1/2". Epoxy coated reinforcing steel shall be used in the top slab when the fill at the shoulder line is less than 6". Kansas requires a rigorous plant inspection to assure proper joint fit-up prior to installation. Kansas has three options for sealing the joints between each precast section: Figure 5.1 displays Option "A" which includes a compound type joint filler and a geotextile fabric, Figure 5.2 displays Option "B" which includes an external sealing band, and Figure 5.3 displays Option "C" which includes an extruded rubber gasket and a geotextile fabric. Additionally, Kansas requires shop drawings to include details of all phases of construction, layout, joint details, lifting devices, casting methods, construction placement, details of any cast-in-place segments or transitions that are required, weights of the precast sections, and the proposed transportation methods.

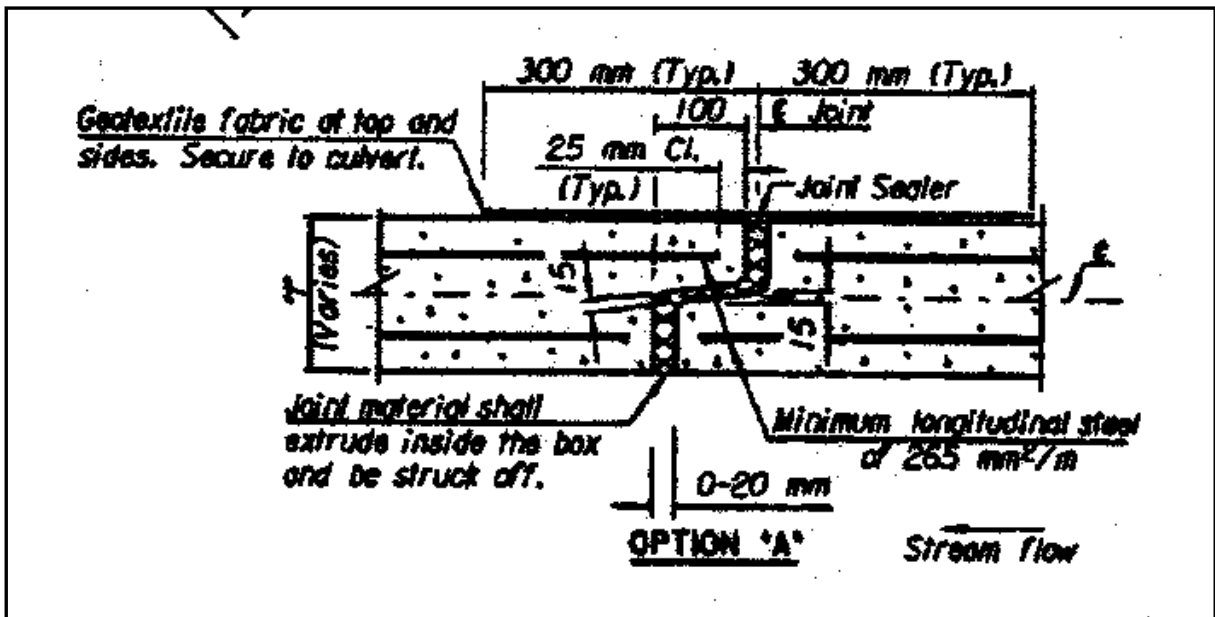

Figure 5.1: Joint Sealer & Geotextile Fabric

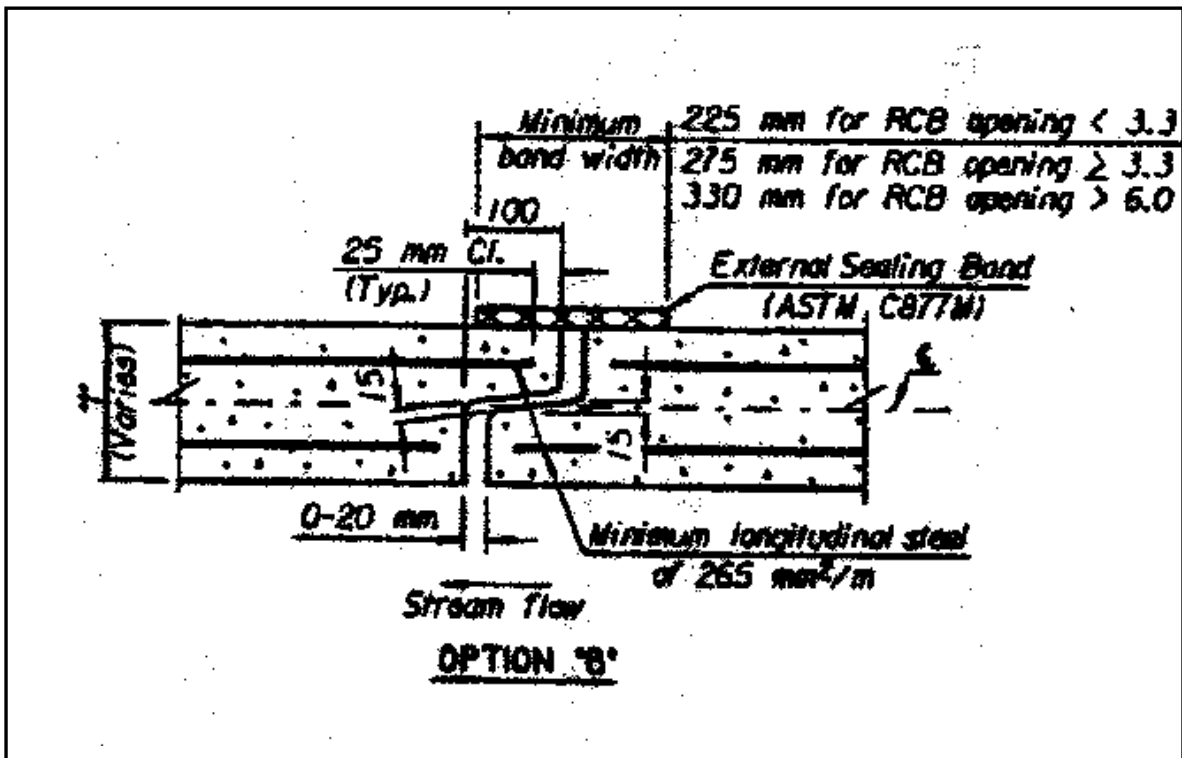

Figure 5.2: External Sealing Band

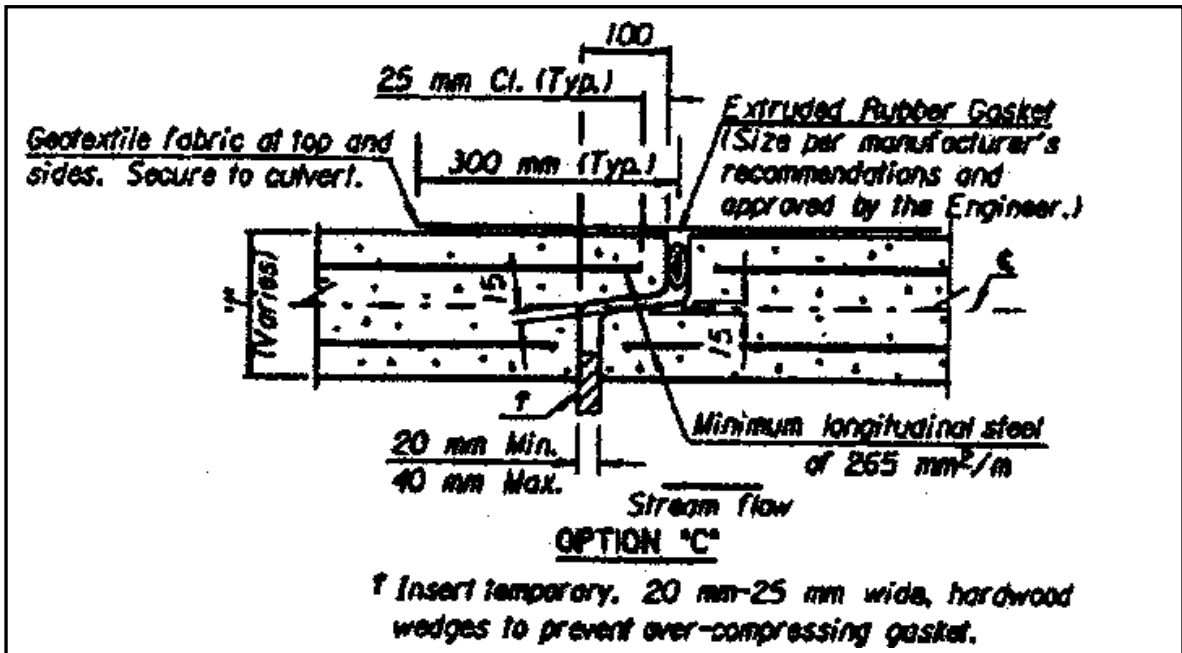

Figure 5.3: Extruded Rubber Gasket & Geotextile Fabric

Problems arose with boxes not fitting together properly in the field, so the specification was changed to require units to be joined in the fabrication plant for inspection of joint fit-up and alignment of adjacent units. And, some tolerances were tightened concerning straightness and squareness of the sections. Since making some changes, there have been no more problems with the fit-up of the boxes. During a multiple barrel installation on a concrete seal course, sand got trapped under the boxes and while filling the gap with grout, the boxes separated causing a 10” gap in some areas. As a result, Kansas now requires a mechanical connection between the boxes or partially backfilling the boxes prior to grouting the joint gap. And due to relatively thin slabs and large amounts of steel at high fill locations, precast box member thickness is limited to not less than three-fourths the thickness of the corresponding member of an equivalent KDOT standard cast-in-place box culvert. Kansas is aware of potential joint problems occurring due to settlement of the fill; and, unless there is minimum fill or a distribution slab, joint loads can pose a problem. But, precast box culverts provide a viable option to the traditional cast-in-place culvert especially when the contractor must complete the project in a timely manner.

Louisiana

Louisiana has been using precast box culverts for a little over 10 years. Although the contractor is normally given the option to use precast or cast-in-place, the Louisiana DOT may specify precast when there is a construction time constraint. Louisiana uses freestanding cast-in-place headwalls with precast barrel designs. To date, there have been no unusual problems associated with precast box culverts. Due to the reduced construction time and in many cases improved quality, precast box culverts are looked upon as an excellent innovation.

Minnesota

Although the Minnesota DOT never responded to the survey, a copy of their standard drawings and specifications was acquired. The foundation shall consist of a minimum of 6” of granular bedding, shaped to a flat base using a template. Compaction adjacent to the bottom corner radii shall be done with a mechanical hand compactor.

There is a 1 ½” minimum and a 2” maximum concrete cover for all reinforcement. A distribution slab is required for fill heights less than 2’. In Minnesota, a cast-in-place distribution slab is defined as a 6” thick slab with #13 bars at 18” transversely and #16 bars at 12” longitudinally. If the fill height is greater than 1’, the distribution slab may be constructed of precast with the same reinforcement. The joints must be centered over the box sections and 3” of granular fill should be provided between the box and the precast distribution slab. The distribution slab may be constructed of precast if the fill height is greater than 1’.

Minnesota’s drawings include a table indicating culvert size and associated concrete compressive strength, fill height range, slab and wall thickness, weight, reinforcement area requirements, and apron information. Individual precast sections shall be tied together with 1” diameter concrete pipe ties. The joint on the bottom of the culvert shall be sealed with a preformed mastic. A strip of geotextile material extending at least 12" on each section shall be placed over the joints on the top and sides to prevent displacement during backfill operations. When required by Contract, joints shall be effectively sealed to provide a flexible, watertight joint using an approved joint sealer material such as a preformed rubber, preformed plastic, or bituminous mastic. For double cell installations where the distance between the barrels is less than 2', use either pea rock or lean mix backfill between the culverts. Also, provide an approved 12” thick grout seepage core between the culvert’s two ends when a minimum distance of 6” is required.

Mississippi

Mississippi does not consider a culvert to be a structure; therefore, the culverts are not inspected on any routine basis. Consequently, there is no data depicting their performance and/or associated problems. Although Mississippi could not provide much input, standard drawings for precast box culverts were sent. The drawings include a table indicating culvert size and associated fill height, slab and wall thickness, and apron and wingwall information. The concrete cover for all reinforcement follows the ASTM C 1433 requirements indicated in Figure 1.1 of Chapter 1

Missouri

Missouri has used precast box culverts as a substitute for cast-in-place culvert sections for nearly 15 years. The MoDOT usually allows the contractor the option to use precast or cast-in-place. But, precast may be specified in circumstances where collars are required (usually in boxes cambered for anticipated settlement) and when it is necessary to quickly complete the construction of a replacement structure. Missouri allows the use of precast end components; however, if the contractor requests that the end section be precast, the MoDOT requires that the barrel, wingwalls, and floor slab be cast as an integral unit. Segmental construction is allowed but considered a modified design to be reviewed by the MoDOT Bridge Unit. The toewall may be connected in either case.

Although Missouri does not have a precast box culvert standard, there are some specifications that contractors must follow. The foundation is required to be a 6" layer of granular material placed directly below the bottom of the box and end sections, and a minimum of 18" beyond each side of the box. The concrete cover for all reinforcement follows the ASTM C 1433 requirements indicated in Figure 1.1 of Chapter 1. All joints between individual box sections shall be sealed with an approved plastic joint compound or a tubular joint seal. Joints shall be forced together with excess compound extruding both inside and outside the joint. For multiple cell installations, a 1 ½" minimum space shall be left between adjacent precast sections and entirely filled with mortar following installation of the end sections.

Although the MoDOT is unaware of any major problems associated with precast box culverts, there have been some construction issues related to pipe inlet requirements through the culvert. Because one contractor drilled a hole into the precast section and created a failure after the backfill was in place, the MoDOT has a standard for pipe inlet reinforcement. In addition, inadequate design loads on excessive fill heights has been a previous design issue. The MoDOT worries because ground failure is always a possibility; however, the probability is low and even less with a preliminary geotechnical report. Precast is a very good option because it allows contractors flexibility in building

culverts while providing a ‘jointless’ unit. Cast-in-place culverts require construction joints at the base and top of the walls.

Nevada

Nevada has been using precast box culverts for the past 25+ years; however, no inventory is kept, so the age of the oldest installation cannot be determined. An estimate of about 15% of all installations are precast. Although the contractor usually has the option, precast is sometimes specified to minimize the duration of traffic lane closures and for remote sites far from the nearest batch plant. The types of precast box culverts include square and rectangular single cell units, as well as multiple cell units constructed by placing and grouting single cells 3” apart from one another. The joints between precast section shall have a maximum tolerable gap of $\frac{3}{4}$ ” and shall be sealed with a flexible, watertight, preformed joint mastic. The concrete cover for all reinforcement follows the ASTM C 1433 requirements indicated in Figure 1.1 of Chapter 1. All end components are cast-in-place and connected to the precast box section by doweling, drilling, or embedment. Practice has proven that it is better to construct junction boxes and connections to laterals as cast-in-place, while allowing precast to continue on either side.

Although the concrete durability of precast is notably better than cast-in-place due to plant production, Nevada has had some problems with the precast joints. Problems typically deal with leakage, seepage, and resulting concrete deterioration. Damage to keys during shipping and installation, inadequate joining of the units or placement of joint material, and settlement are the predominate causes of this damage. In addition, post construction installation of lateral conduits seems to yield widely varying results because the quality of construction can be very poor and can have a significant impact on the long term performance of the boxes. In order to alleviate some of these problems, the Nevada DOT is working with construction personnel and contractors to ensure that the boxes are properly constructed and installed in accordance with specifications. The overall the experience with precast has been good and there are no reservations about its continued use.

New Hampshire

In response to the survey, New Hampshire sent specifications for precast box culverts as well as the resumes of seven precasters. The specifications indicate that the shop drawings must include the following:

- Fully and accurately dimensioned views of the precast units showing the geometry of the sections, including all projections, recesses, notches, openings, blockouts, etc.
- Details and bending schedules of steel reinforcing showing clearly the size, spacing, and location including any special reinforcing required but not shown on the contract plans in the proposal.
- Details of any reinforcing or ties provided under lifting devices. Details and locations of all items to be embedded in the sections such as inserts, lifting devices, etc.
- Quantities for each section, including concrete volume, reinforcing steel weight and total section weight.
- A description of the methods of curing, handling, storing, transporting, and erecting sections.

New Jersey

In response to the survey, New Jersey sent standard drawings and specifications which are summarized in the following paragraphs. Precast reinforced concrete box culverts shall not be used where the top slab will be used as a riding surface. The use of precast concrete end sections, including headwalls, is permitted upon approval, except when the skew angle requires that the smallest side of the precast segment be less than 3'. Figures 5.4 & 5.5 display typical cast-in-place details for headwall and toewall connections to their respective top or bottom slab. The concrete for precast concrete culverts shall have a minimum design compressive strength of 5,000 psi and the reinforcement shall conform to ASTM A 615, Grade 60. Welded deformed steel wire fabric conforming to AASHTO M 221 and having a diameter of at least 3/8" may be substituted for deformed bars. Concrete cover over the reinforcement shall be 1 1/2", except on the top slab where it shall be 2". When the earth fill is less than 2', the top mat of reinforcement in the roof slab shall be corrosion protected. Wall thickness shall be a minimum of 8", and top and bottom slab thickness shall be a minimum of 10". Precast

units shall be tied together with a minimum of four longitudinal rods or strands to ensure an adequate seal and to provide continuity and concrete shear transfer between the precast units. These ties shall be $\frac{3}{4}$ " high-tensile strength steel bars conforming to AASHTO M 275 or $\frac{1}{2}$ " Grade 270 poly-strands conforming to AASHTO M 203. Figure 5.6 shows the end box section elevation displaying the hand holes for post tensioning. Please refer to Appendix F to find New Jersey's post tensioning details.

An approved flexible, watertight neoprene gasket shall be provided at joints between the units: The gasket shall be continuous around the circumference of the joint and contain only one splice. Figure 5.7 displays a typical joint detail between precast sections. Precast units shall be given one coat of an epoxy waterproofing seal coat on the exterior of the roof slab. There shall be waterproofing between the last precast section and any cast-in-place sections. Prior to backfill, a 2' wide strip of filter fabric shall be placed over the top and side transverse joints. Lifting holes shall be grouted and coated with one coat of epoxy waterproofing seal coat. Lifting devices used in handling and erection shall be galvanized. There shall be a compacted coarse aggregate layer provided under the culvert with a minimum depth of 2', extending 12" on each side of the culvert. For multiple cell installations, the cells shall be placed a maximum of 6" apart and filled with non-shrink grout or crushed stone, with a 2'-8" wide strip of filter fabric placed over the longitudinal joint.

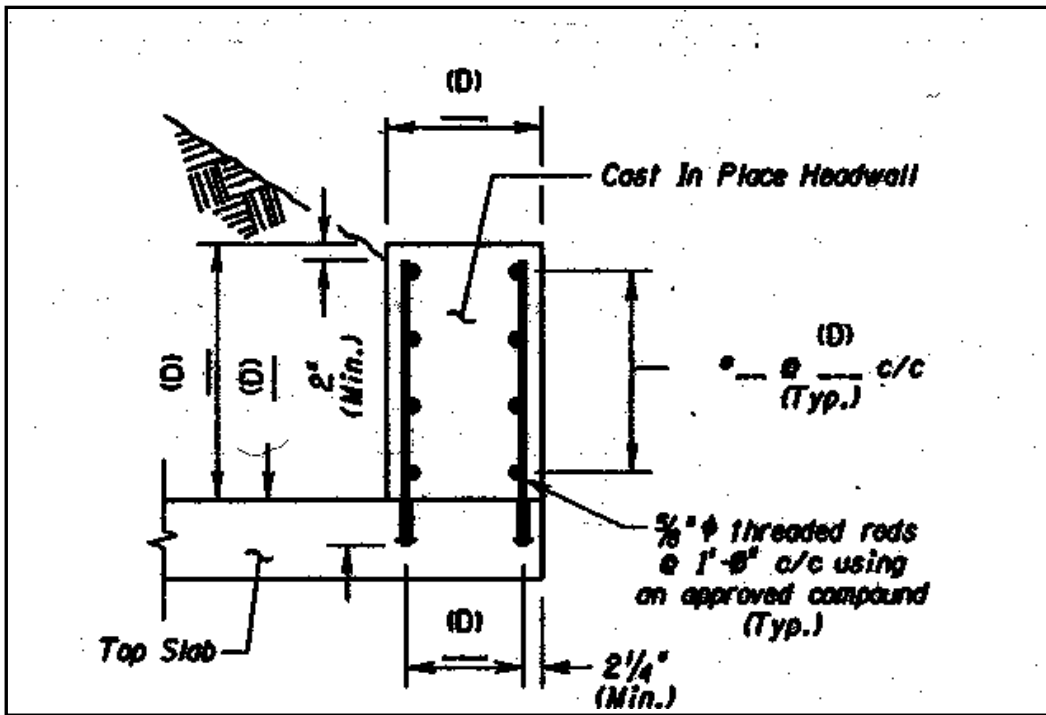

Figure 5.4: Typical Headwall Detail

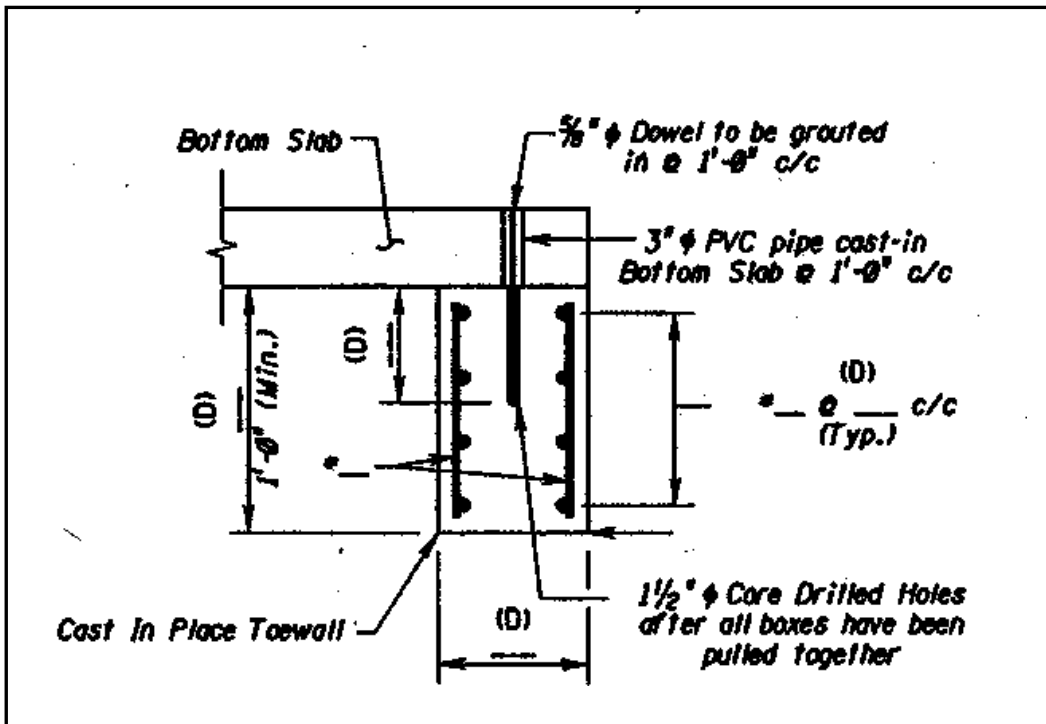

Figure 5.5: Typical Toewall Detail

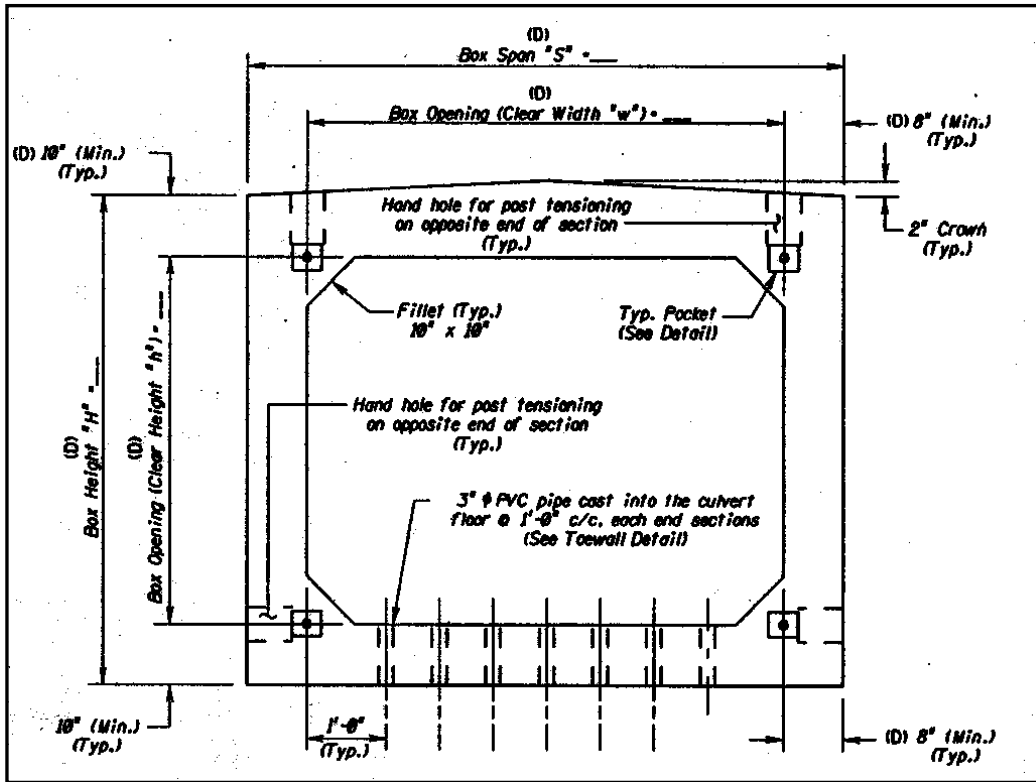

Figure 5.6: Box Culvert End Elevation

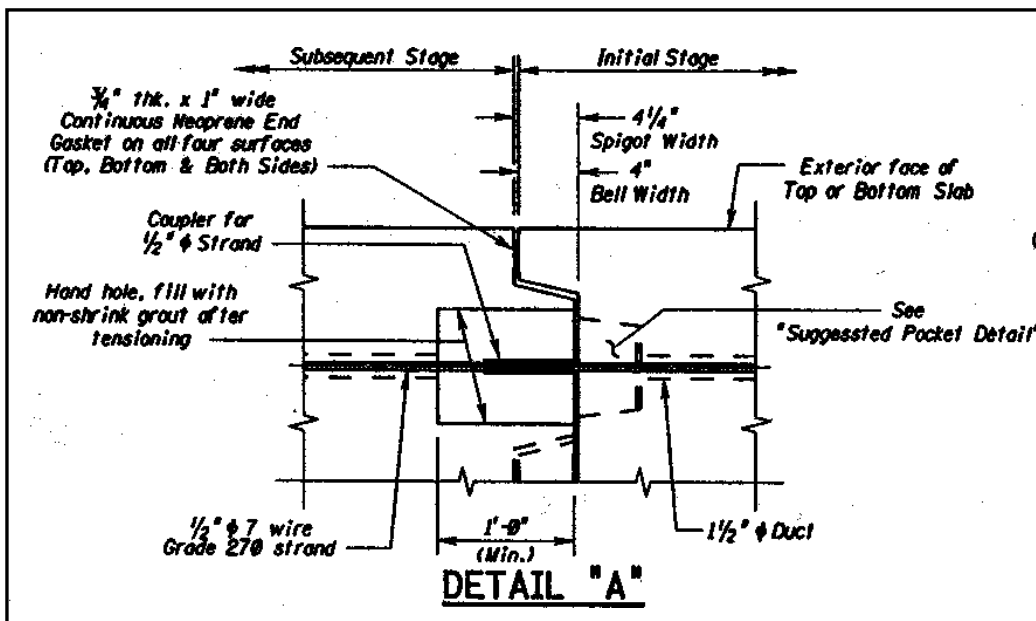

Figure 5.7: Joint Detail

New Mexico

New Mexico is only aware of one precast box culvert installation at the present time. Although the New Mexico DOT is not sure why precast box culverts are not used, it may be because no precast standards have been developed and precasters may not see New Mexico as a big market.

New York

New York's oldest precast box culvert installation dates back to about 1980. Although there is no way to track box culvert installations, the majority of concrete culverts installed are precast. The regional design engineers decide when to use a precast or cast-in-place box culvert. The types of precast box culverts used include square and rectangular, single and multiple cell units and larger three-sided systems such as CON/SPAN, HySpan, and Bebo. The headwalls are usually cast-in-place because they lend a little more flexibility to the alignment; but, the use of precast wingwalls has been increasing over the past few year to the point where precast is being used in about half of the wingwall installations. Currently, the NYSDOT's Structures Division committee is preparing some standard design sheets showing all typical precast box culverts and wingwall details.

New York maintains standard specifications for precast box culverts. Some of the requirements include the following: The concrete cover for all reinforcement follows the ASTM C 1433 requirements indicated in Figure 1.1 of Chapter 1. All reinforcing steel in the top mat of the roof slab shall be epoxy coated or the concrete shall contain a corrosion inhibitor. The ends of the longitudinal reinforcing steel shall have a ½" minimum concrete cover at the mating surface of the joint. There is a joint depth minimum of 2" and a maximum of 4". The gap between adjacent culvert sections shall be a maximum of ¾". The joints shall be sealed with a continuous gasket installed at the precast plant. The joints shall be drawn together with a mechanical connector. Culverts with a clear rise greater than 4' shall have a minimum of four connectors required per joint, unless approved by the Engineer. If required by the contract plans or the Contractor decides to leave the connectors in place, they must be located so as not to cause an obstruction in the

culvert. There are specific requirements for interior and exterior wall thickness depending upon the clear span of the culvert.

In 1994, New York performed an informal visual inspection of three or four of the oldest precast culverts and no problems were found to be affecting their performance. But, there have been some problems with leaky joints between culvert sections. There is a compressible foam gasket in the joint to prevent backfill from seeping into the joint; but, it does not provide a water tight joint. Because some of the regional engineers do not want the joints to leak, a waterproof membrane is specified to cover the joints. In addition, there was some undermining of wingwalls that were placed on a crushed stone base; however, this practice is no longer allowed. Overall, New York is very pro precast box culvert because the precasters manufacture a good product. Units can be manufactured ahead of time in a controlled environment and installed on a project much quicker than cast-in-place. Because the cost of maintenance and protection of traffic on a culvert job can be high, the quick installation time of a precast culvert can be a real advantage.

Ohio

Ohio has been using precast box culverts since 1979. Currently, very little cast-in-place is being used unless the load requirements mandate the slab thickness to be greater than what a precaster can manufacture, usually greater than 16". Precast is almost always given preference in the designs because of the ease of design and construction. Although, the contractor is sometimes given the option, it is rare for the contractor to choose cast-in-place because the labor and time required can rarely beat out precast. Aside from the square and rectangular types, Ohio also utilizes the three-sided flat topped structures as well as precast arch-top structures. As for the end components, they can be either cast-in-place or precast. A precast wingwall design must be submitted to the Office of Structural Engineering for approval; however, a standard wingwall design is currently being worked on. Although Ohio is moving in the precast direction, most wingwalls, headwalls, and endwalls are still cast-in-place.

Although Ohio does not have a standard for all types of precast culverts that are installed, there are specific specifications for each type. The following pertains only to four-sided precast box culverts. Structures with a span less than or equal to 12' are designed in accordance with ASTM C1433; but, structures with spans greater than 14' require a special design available from the Office of Structural Engineering. A table indicates the maximum fill heights, according to culvert size. The foundation shall consist of structural backfill extending at least 6" below the bottom of the box and 2' on each side of the box. The joints shall be filled with a bituminous, preformed butyl rubber, or a flexible gasket joint filler. For any exterior joint not covered by membrane waterproofing, center a 9" wide strip of continuous joint wrap over the joint, sufficient to extend from the bottom of one vertical face to the bottom of the other vertical face. If shown on the plans, externally apply membrane waterproofing to the top surface and extend it down each side of the structure. Waterproofing membrane should be applied to all surfaces that will be in contact with the backfill material.

A common error in the plans concerns the inlet/outlet ends. Figures 5.8 and 5.9 show the inlet and outlet details that Ohio is currently incorporating into their drainage manual. These details can ensure that the inlet ends are being accurately installed with a spigot end, which provides a bevelled entrance. Previously submitted details indicated a squared "cut-off" end instead of this bevelled bell end. Because the inlet and outlet ends significantly impact the hydraulic performance of the culvert, they need to be shown correctly in the plans. In addition to the traditional benefits to precast, such as timeliness and quality, Ohio believes that design time is an added advantage: The culvert details have been used so frequently that the plans are beginning to become very cut-and-paste. And, once properly waterproofed, the precast box culverts are nearly maintenance-free. In the early years of precast culverts, there were joint leakage issues; but, this was solved with the addition of a water-proofing membrane over the exterior joints to the specification. Ohio currently has a precast supplier certification program that helps to ensure that all precast manufacturers are producing consistent, good quality precast items.

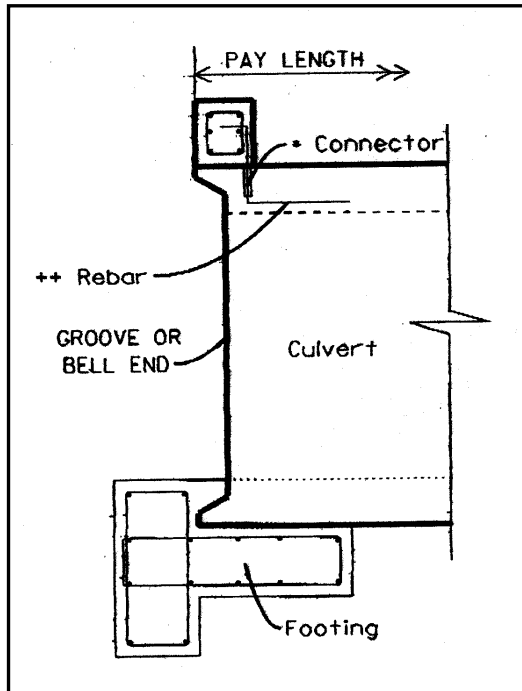

Figure 5.8: Inlet End Detail

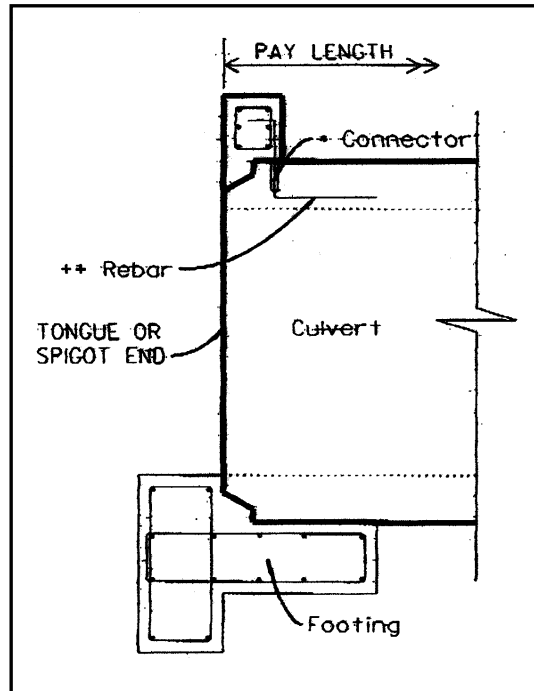

Figure 5.9: Outlet End Detail

Oregon

Although the Oregon DOT never responded to the survey, a copy of their standard drawings was acquired. The concrete cover for all reinforcement follows the ASTM C 1433 requirements indicated in Figure 1.1 of Chapter 1. The drawings include a table indicating culvert size and associated fill height range, slab and wall thickness, reinforcement area requirements, and joint seal data. The minimum fill for precast box culverts is 2’.

Pennsylvania

Pennsylvania responded to the survey by providing standards for precast box culverts and the CON/SPAN Bridge Systems. The following is incorporated into the standard for the precast box culvert. The wall and slab thickness ranges from 8"-12" depending on culvert size. For culverts with less than 2’ of fill, the following indicates the concrete cover requirements over the reinforcement. Welded wire fabric (WWF) requires a 2" cover for the top wires of the top and bottom slab and a 1 ½" cover on all

remaining wires. Conventional bars require a 2 ½" cover for the top bars of the top and bottom slab and a 1 ½" for all remaining bars. For culverts with greater than 2' of fill, the following indicates the concrete cover requirements over the reinforcement. Welded wire fabric (WWF) requires a 2" cover for the top wires of the bottom slab and a 1 ½" cover on all remaining wires. Conventional bars require a 2" cover for the top bars of the top and bottom slab and a 1 ½" for all remaining bars. For less than 2' of fill, a 5" minimum reinforced concrete deck is required. An approved 2' wide waterproofing membrane or adhesive-backed preformed membrane shall be provided along side joints and joints in the top slab of box culverts with less than 2' of fill. Finally, precast end components may be used only if reviewed and approved by the District Bridge Engineer.

The CON/SPAN standards include construction specifications and typical details. The specification section discusses the proper excavation, foundation, erection, backfilling, drainage, and dewatering requirements. The following is included in the erection section. An approved concrete membrane sealer is required on the top of the arch segments as well as the mating joints between each arch segment for the full length of the structure. For spans greater than 24', shipping and placement cables are provided to prevent the legs from spreading during shipment and installation. These cables should not be removed until after the segment is installed and grouted. A strip of butyl rope should be placed along the entire length of the joint exterior and covered with a 9" wide joint wrap. Figure 5.10 shows a typical joint wrap detail. Also provide a 2' wide strip of filter fabric for the rear face of the joint between the precast arch sections and the precast wingwalls. Finally, precast units should be mechanically attached to the cast-in-place footings through the use of angles and adhesive anchors. The standard drawings provide details for various end components and data for arch culverts with spans ranging from 12-48'. The data includes the center of gravity, concrete section areas, waterway areas, geometric properties, required reinforcement areas and lengths, and cover heights. Please refer to www.dot.pa.us/newproducts/index.htm or Appendix F to find the complete CON/SPAN specifications and details.

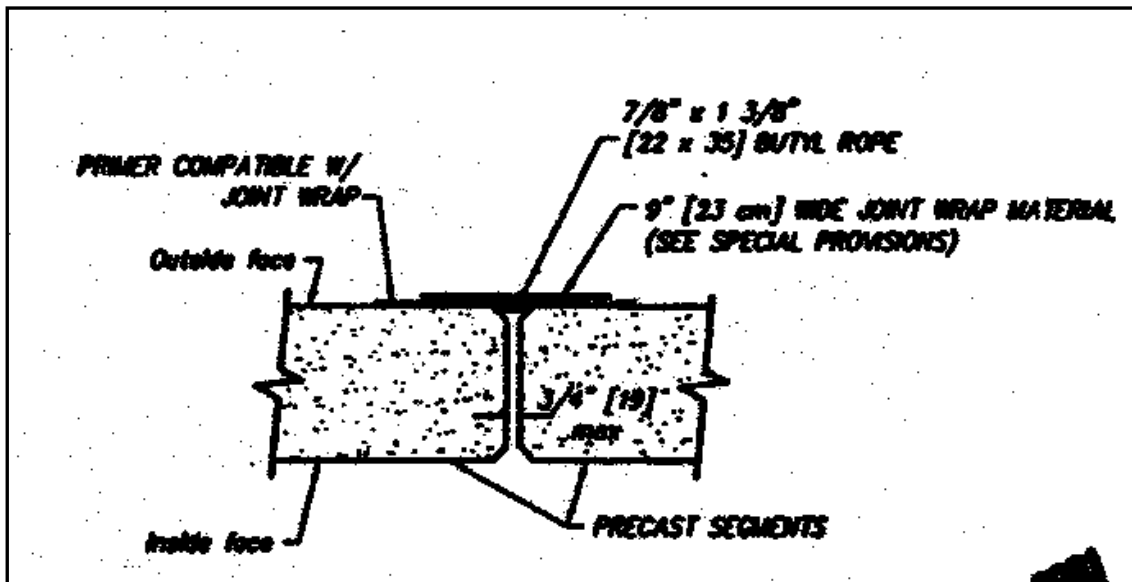

Figure 5.10: CON/SPAN Joint Wrap Detail

South Dakota

South Dakota has been using precast box culverts since the early 1980's. When the option is included in the plans, precast is utilized almost all of the time. But, not all plans include a precast option due to skews, special inlet/outlet features, etc. On all State projects, precast box culverts are used more than 50% of the time. Precast boxes are only available in single and twin barrel configurations with straight wingwalls. Although South Dakota does not have any standards for precast box culverts, specifications are maintained to ensure proper design, fabrication, and installation. There is a minimum length for precast box culvert units of 4'. Each section must be joined to adjacent sections with 1" diameter joint ties. Refer to Figure 5.11 or www.sddot.com/pe/roaddesign/docs/Standard_Plates/English/s56001.pdf for a detail of the typical tie bolt assembly. Dry casting of precast sections is not allowed. The foundation bedding shall be sand or selected sandy soil. The floor joints between adjacent sections shall be sealed with a preformed mastic to a point above the flow line. A 2 1/2' strip of drainage fabric shall be centered along the section joints. Transverse joints in the fabric shall be overlapped at least 2'. A sufficient adhesive is required along the edge of the fabric to hold it in place during backfill operations.

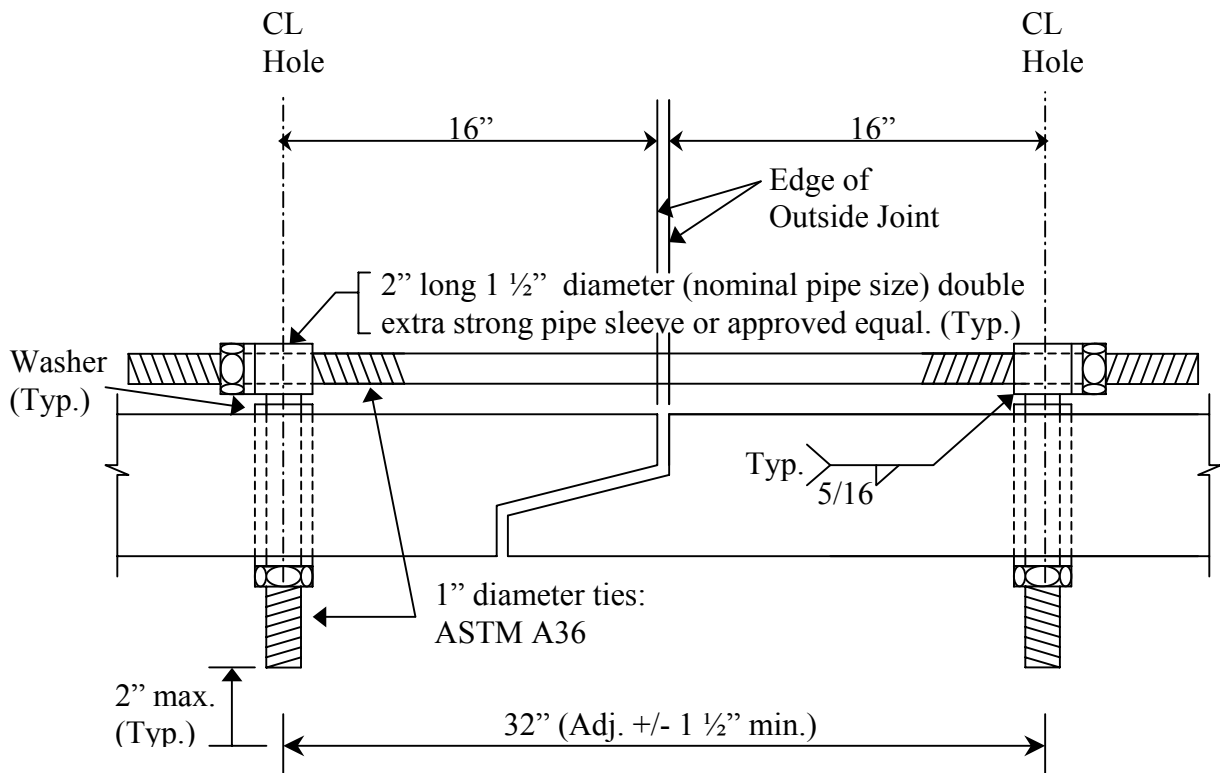

Figure 5.11: Typical Tie Bolt Assembly

Precast box culverts offer construction time savings and may fit some contractor's grading operations better, resulting in lower overall project bids. Problems typically experienced in the field with precast box culverts include poor quality of concrete and dimensional control; but, this can be minimized with rigorous plant inspections. Also, precast boxes seem to be very sensitive to the care that the contractor puts into their installation: There have been problems getting the joints to fit tight and with concrete spalling due to impact with other sections and/or equipment. In addition, an earlier box did not incorporate inlet/outlet cutoff walls and experienced piping under and around the box sections. This resulted in erosion under the entire length and around the ends along with major settlement of the sections. Consequently, the SDDOT recommends that inlet and outlet cutoff walls be specified on all drainage crossing type precast boxes.

South Dakota has had a very long and very good history with cast-in-place box culverts, and their only problems have been associated with the joints. Although precast box culverts have been performing well, there is always some degree of concern due to the large number of joints. Because South Dakota is not aware of any failures or sinkhole developments through the joints of the tied precast sections, it appears that the joint treatment has been working. The SDDOT believes that only time will tell if these precast culverts will hold up against the cast-in-place boxes.

Tennessee

Tennessee has been using precast box culverts for about 25 years; however, the frequency of use has been very small compared to cast-in-place: About 1% of all culverts are precast. Only square and rectangular precast boxes are used and all end components are cast-in-place. Tennessee has developed a standard for precast box culverts to include drawings and construction specifications. The concrete cover for all reinforcement follows the ASTM C 1433 requirements indicated in Figure 1.1 of Chapter 1. The drawings include a series of tables indicating culvert size, fill height, slab and wall thickness, and reinforcement area requirements. The bedding shall consist of a 6" granular foundation fill. The joints shall be filled with a butyl rubber or approved bituminous plastic or cement mortar. For multiple cell installations, the gap between the sections shall be filled with either flowable fill grout or sand with at least the top 2' filled with flowable fill grout.

Although Tennessee has developed a precast box culvert standard, contractors seem reluctant to use it. This may be because the standard has not been out long enough for the contractors to familiarize themselves with it or because smaller contractors can build cast-in-place culverts with their own work force and pocket more profit. Because Tennessee does not favor any contractor over the next, the contractors are allowed to decide whether to use cast-in-place or precast. The advantages to precast are the speed of installation and the higher quality of the concrete. Tennessee is not aware of any big problems with precast box culverts and does not worry about the joints being an issue.

Years ago, the precast boxes were required to be post-tensioned together; but, it was subsequently decided that this practice was not necessary.

Texas

Texas has been using precast box culverts since the mid 1970's, and a precast standard was developed in the early 1980's. Currently, about half of the culverts are precast. On most projects, the use of precast is the contractor's decision; however, the TxDOT may specify precast when the speed of construction is very important. TxDOT has had very few problems with the performance of their precast box culverts. There have been occasional settlement problems which were related to poor compaction of the sub-grade prior to placement of the boxes. Texas maintains a standard for precast box culverts that is the result of an evolution in precast culvert design from the past 20+ years. The concrete cover for all reinforcement follows the ASTM C 1433 requirements indicated in Figure 1.1 of Chapter 1. The drawings include tables indicating culvert size, fill height, slab and wall thickness, reinforcement area requirements, and section lift weight as well as some typical miscellaneous details. Figure 5.12 shows culvert data for a span of 3'. This table coincides with the diagram of the ASTM C 789 Standard in Figure 5.13, similar to the ASTM C 1433 Standard located in Chapter 1. Please refer to <http://www.dot.state.tx.us/insdot/orgchart/cmd/cserve/standard/bridge-e.htm#Culvert> or Appendix F to find the complete Texas standard for precast box culverts spanning up to 12'.

Most of the precast culverts are single cell precast boxes; however, multiple barrel, U-shaped, and a three-sided culverts are also utilized. Multiple barrel installations are achieved by placing single cells side-by-side. Figures 5.14 shows the standard details for the placement of multiple cell units. One U-shaped system uses two U-shaped sections placed one on top of the other to form a box; and another uses one U-shaped section with a flat slab placed on top. These systems are used as a contractor's alternative to the conventional precast box culvert and their main advantage is the reduced weight of each section easing transportation and installment. The TxDOT does not maintain any state-wide standards for these types of culverts. Finally, "C-Span"

culverts, manufactured by CON/SPAN, are used. Texas does not maintain a standard for these structures; therefore, their design and construction is handled through a special specification. The main objection to these structures is their lack of a bottom slab for scour protection of the channel bottom; and, there is concern about additional scour because these structures are placed on spread footings. Please refer to the Pennsylvania section on pages 49 & 50 for more information on CON/SPAN's details and specifications.

SECTION DIMENSIONS					Fill Height (ft)	M (Min)	REINFORCING (in ² /ft) ②								Lift Weight (Tons) ①	Governing ASTM Standard
S (ft)	H (ft)	T _T (in)	T _B (in)	T _S (in)			A _{S1}	A _{S2}	A _{S3}	A _{S4}	A _{S7}	A _{S8}	A _{S5}	A _{S6}		
3	2	7	6	4	< 2	-	0.17	0.34	0.20	0.13	0.17	0.14	0.17	0.17	3.3	C 850
3	2	4	4	4	2	17	0.19	0.20	0.21	0.10	-	-	-	-	2.4	C 789
3	2	4	4	4	3	15	0.10	0.11	0.11	0.10	-	-	-	-	2.4	C 789
3	2	4	4	4	8	15	0.10	0.10	0.10	0.10	-	-	-	-	2.4	C 789
3	2	4	4	4	10	15	0.10	0.11	0.11	0.10	-	-	-	-	2.4	C 789
3	2	4	4	4	12	14	0.10	0.13	0.13	0.10	-	-	-	-	2.4	C 789
3	2	4	4	4	14	14	0.11	0.14	0.14	0.10	-	-	-	-	2.4	C 789
3	2	4	4	4	16	14	0.12	0.16	0.16	0.10	-	-	-	-	2.4	C 789
3	2	4	4	4	18	14	0.13	0.17	0.18	0.10	-	-	-	-	2.4	C 789
3	2	4	4	4	20	14	0.14	0.19	0.19	0.10	-	-	-	-	2.4	C 789
3	3	7	6	4	< 2	-	0.13	0.36	0.22	0.13	0.17	0.14	0.18	0.17	3.7	C 850
3	3	4	4	4	2	27	0.15	0.24	0.25	0.10	-	-	-	-	2.8	C 789
3	3	4	4	4	3	20	0.10	0.13	0.14	0.10	-	-	-	-	2.8	C 789
3	3	4	4	4	6	17	0.10	0.10	0.10	0.10	-	-	-	-	2.8	C 789
3	3	4	4	4	8	15	0.10	0.11	0.11	0.10	-	-	-	-	2.8	C 789
3	3	4	4	4	10	15	0.10	0.12	0.13	0.10	-	-	-	-	2.8	C 789
3	3	4	4	4	12	15	0.10	0.14	0.14	0.10	-	-	-	-	2.8	C 789
3	3	4	4	4	14	15	0.10	0.15	0.16	0.10	-	-	-	-	2.8	C 789
3	3	4	4	4	16	15	0.10	0.17	0.18	0.10	-	-	-	-	2.8	C 789
3	3	4	4	4	18	15	0.10	0.19	0.19	0.10	-	-	-	-	2.8	C 789
3	3	4	4	4	20	15	0.11	0.21	0.21	0.10	-	-	-	-	2.8	C 789

Figure 5.12: 3' Span Sample Culvert Data

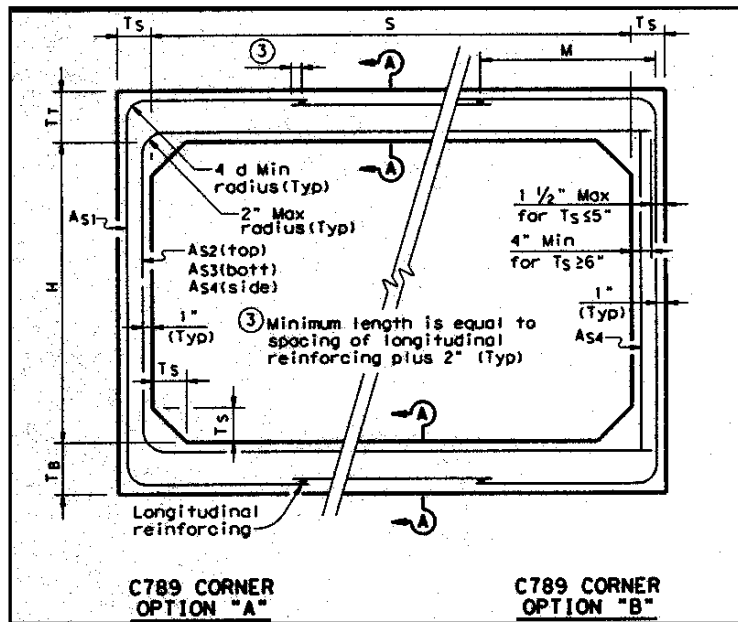

Figure 5.13: C 789 Standard

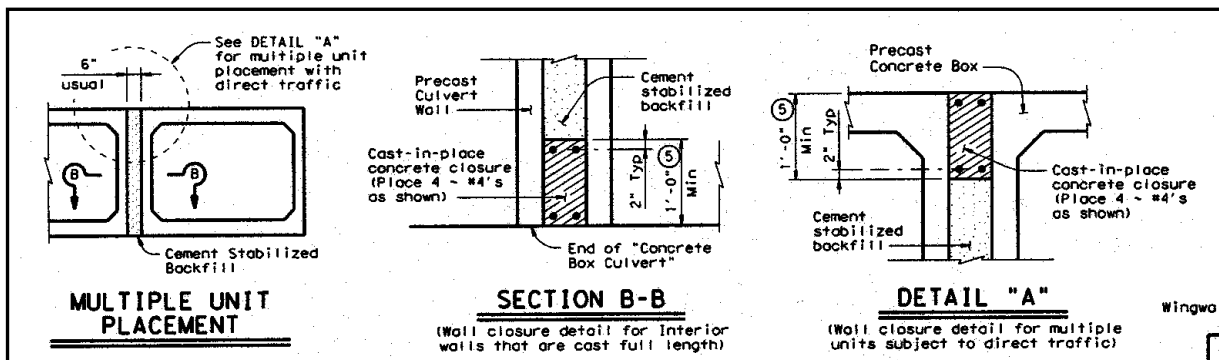

Figure 5.14: Multiple Unit Placement Details

Virginia

Virginia first began using precast box culverts around 1977. Although the plans are typically detailed for cast-in-place culverts, in almost every instance, the contractor may opt to use precast. Aside from the few instances when cast-in-place is mandated, contractors chose to use precast almost 100% of the time. The Virginia DOT occasionally specifies precast when there is a need for rapid construction in order to

minimize the amount of road closure time. Overall, the frequency of precast is approximately 90-95%. Besides the single cell application, Virginia has used a multiple cell precast installation consisting of more than one line of single cell units. Either precast or cast-in-place wingwalls and headwalls are allowed: 60-70% of the contractors opt to use precast end components.

Virginia has experienced problems with joints that were not sealed properly and began to leak. And, there were initially some cases where the fabrication was unacceptable and rejected. But, the fabricators have grown accustomed to the requirements and now there are very few design and construction problems. Discontinuity is always a potential problem, but is most likely to occur with bad fit-up. It is recommended that the gap between units after placement not exceed a maximum of 1/2" to 3/4". Proper fit-up and sufficient end anchorage (toe or scour wall is either cast-in-place to "anchor" the line or sufficient mass is provided in the precast end section to resist sliding) should prevent the precast units from separating due to internal pressures. Designs should be structurally adequate, have an aesthetic method of finishing the ends so that the structure looks good, and installed with minimal joint openings that are adequately sealed to prevent infiltration. Bad designs are ones in which the minimum area of steel is used and no care is taken in regards to the aesthetics of the final structure. Virginia has used precast box culverts quite extensively and they have served their purpose well. But as with all precast units, the design and fabrication need to be closely monitored in order to ensure a viable long-term product.

Washington

Washington has been using four-sided precast box culverts for about 10 years and more recently began using three-sided precast culverts that do not have a bottom slab. Generally, precast is specified for all new installations and cast-in-place is specified for extensions to existing cast-in-place culverts; therefore, precast is utilized on about 90% of the projects. The wingwalls and headwalls are usually precast and are attached after the culverts have been installed. There appears to be no maintenance problems with the four-sided culvert and recent inspection reports indicate that the three-sided structures are also

performing well. But, there have been some problems due to poor fit-up that could lead to maintenance problems in the future. To ensure proper fit-up, it is important to provide even soil bedding for the foundation of these structures.

A good design incorporates good crack control and concrete cover requirements. And, if the structure does not have much soil cover, epoxy coated bars or an increased concrete cover is required. Although there have been no instances of failure, one manufacturer provides a system made up of three separate pieces, a top slab and two walls. When the pieces are assembled at the site, the structure is unstable until the backfill has been placed and a washout could cause instability during the service life of the structure. Due to this reasoning, a moment connection is required for these structures. Overall, Washington believes that precast box culverts provide good economy and rapid installation compared to cast-in-place culverts.

Wyoming

Wyoming began using precast box culverts on a limited basis in 1983. Today, precast is specified on a majority of the projects due to speed of construction, ease of installation, and project location for sites miles away from a batch plant. During the design phase, the Wyoming DOT decides whether the box culvert will be precast or cast-in-place. Although there are no strict guidelines for their use, precast boxes are preferred due to various construction issues. Aside from the single cell installation, Wyoming has utilized some double cell installations. U-shaped units are not used due to scour and foundation concerns. Cheyenne has recently installed some three piece culverts which are essentially a square box with a longitudinal joint in each wall yielding a smaller section to manufacture and install. Although the wingwalls and headwalls are usually cast-in-place, precast wingwalls are sometimes used. Although many of the precast installation are not inspected, the Wyoming DOT is not aware of any performance issues.

5.3 Problems and Solutions

The following summarizes the problems and solutions encountered by each state during the design, construction, and installation of precast box culverts.

Colorado

Problem: A local precast supplier advanced the idea of waiving the minimum concrete cover requirements and substituting them with a minimum of 1" thick cover due to the fabricators use of high strength welded-wire fabric and the ability to obtain increased concrete strength and decreased permeability in the fabrication yard. This idea won it a place on the pre-approved products list and the lighter weight and thinner precast box culverts began showing up on projects; occasionally as a substitute for the cast-in-place box culverts. Contractors were accustomed to rolling construction equipment over the top of the new boxes prior to any significant amount of fill being in place. This practice resulted in cracking the tops of the boxes; consequently, the boxes had to be torn out and replaced.

Solution: The Culvert Committee issued a call to have the thin-walled precast boxes removed from the pre-approved products list.

Illinois

Problem: "Fit-up" between sections has allowed soil to infiltrate through the joints and cause settlement of the overlaying pavement

Solution: Corrected by visiting the fabrication plant and identifying necessary adjustments in their process. Also modified policy to not only require mastic at every joint but also to wrap every joint with geotechnical fabric.

Kansas

Problem: Boxes not fitting together properly in the field

Solution: Changed specification to require units to be joined in the fabrication plant for inspection of joint fit-up and alignment of boxes. Plus, tightened up some tolerances relating to straightness and squareness. Haven't heard of any more problems related to fit-up.

Problem: Contractor was installing two single barrel boxes that were setting on a concrete seal course. Sand must have gotten under the boxes because when the space between the

boxes was being filled with grout, the boxes began separating. Instead of a 1” gap between the boxes, ended up with a 10” gap in some areas.

Solution: Require a mechanical connection between the boxes or partially backfilling the boxes prior to grouting.

Problem: Fabricators were putting large amounts of steel into thin slabs at high fill locations.

Solution: Limit precast box member thickness to not less than three-fourths the thickness of the corresponding member of an equivalent KDOT Standard cast-in-place rigid frame box culvert.

Missouri

Problem: Problems when a pipe inlet is required or a hole to be cast into the culvert. One contractor elected to drill a hole in the side of one of these after casting and created a failure after the fill was in place

Solution: Standard for pipe inlet reinforcement, but it should be clearly spelled out on the plans initially.

New York

Problem: Leaky Joints

Solution: Some of our regional engineers don't want any leaky joints however so they specify a waterproof membrane to cover the joints.

Problem: Some undermining of wingwalls that were placed on a crushed stone base

Solution: That practice is no longer allowed

Ohio

Problem: During the early years of use, there were rare cases of backfill material and/or water getting in through joints.

Solution: Easily solved by adding a waterproofing membrane over the exterior joints in the specification. Waterproofing is accomplished through the use of Bituminous Pipe

Joint Filler, filling the top exterior and bottom and side interior joint gaps with mortar. Exterior side joints are covered by a joint wrap (ODOT Construction and Materials Specification 512.09) and the top of the structure is covered by a Membrane Waterproofing material (CMS 512.10).

South Dakota

Problem: One of our earliest triple 10'x 10' installations (3 single 10'x 10's adjacent to one another) did not incorporate cutoff walls and experienced piping under and around the box sections. This resulted in severe erosion under the entire length and around the ends along with major settlement of the sections.

Solution: We would recommend that inlet and outlet cutoff walls be specified on all drainage crossing type precast boxes.

Texas

Problem: Settlement due to poor compaction of subgrade

Solution: Better compaction of subgrade

Virginia

Problem: Experienced problems with joints that were not sealed properly and thus began to leak.

Solution: Problem seemed to be due to poor fit-up rather than bad joint material. Virginia recommended that the gap between units after placement not exceed 1/2" to 3/4" maximum, at the discretion of the inspector. This fit-up, coupled with a sufficient end anchorage that prevents the precast units from separating due to internal pressures, seems to be working well for Virginia.

Problem: There were initially several cases where the fabrication was unacceptable and had to be rejected.

Solution: The fabricators have become accustomed to our requirements and now we have very little problems from a design standpoint and very seldom hear of installation problems.

Washington

Problem: With a three-sided structure composed of three separate pieces (top and 2 sides), a washout could cause instability during the service life of the structure

Solution: Require moment connections

Problem: Poor fit-up and appearance

Solution: Provide even soil bedding for the foundation

Wyoming

Problem: Complaints centered around the field gap between the adjacent sections

Solution: Can be minimized with proper construction practices and supervision. As a part of the fabrication process, require that the fabricator assemble at least three sections, chosen by the quality control inspector – fit shall meet the same requirements as specified for final assembly.

5.3 State Survey Summary

Precast box culverts have been used for approximately 10 – 25 years with the majority of the states installing their first precast box culvert in the late 1970's and early 1980's. Table 5.1 indicates each state's percentage of use of precast as opposed to cast-in-place concrete box culverts.

Table 5.1: Percentage of Precast Box Culverts in Other States

No precast	New Mexico
Less than 10% precast	Arizona, Delaware, Georgia, Tennessee
10-15% precast	Colorado, Kansas, Nevada
50-60% precast	Illinois, South Dakota, Texas
Greater than 90% precast	New York, Ohio, Virginia, Washington, Wyoming

Most of the states indicated that cast-in-place box culverts are detailed in the plans; however, the contractor usually has the option to use precast. If the Contractor decides to use precast, he/she must provide plans in accordance with the standard specification. The Contractor will normally opt to use precast when there is a time

constraint, to minimize lane closures, and if the location is remote and not close to a batch plant. But, precast is usually not recommended in areas subject to flooding with high scourable flow line soils, in areas with excessive settlement, in high seismic zone regions, in areas with “imperfect trench”, in areas where pile foundations are required, and in areas where collars are present. But in the state of Washington, the DOT generally specifies precast for all new installations and cast-in-place for extensions to existing cast-in-place culverts; therefore, the decision is not made by the Contractor. In Wyoming, the DOT makes the decision during the design phase; and, because Wyoming does not have any firm guidelines, precast is usually preferred due to various construction advantages.

Table 5.2 indicates the types of precast culverts used in each state. For the culvert end components, such as the wingwalls, headwalls, and toewalls, the majority of the states specify and use cast-in-place. However, a few states are heading in the directions of precast wingwalls. In New York and Virginia, about half of the wingwalls are now precast. And Ohio is currently developing a standard specification for precast wingwalls. In Washington, the wingwalls and headwalls are precast and are attached after the culvert is installed. In Wyoming, sometimes precast wingwalls are used.

Table 5.2: Types of Precast Culverts in Other States

Four-sided single cell units	All
Multiple cell units (multiple lines of single cells)	All
Three-sided with a flat top	Ohio
Three-sided with an arched top	Arizona, Delaware, Georgia, New York, Ohio, Pennsylvania, Texas
Three-sided (not sure of the type of top)	Illinois, Washington
Three-sided (three separate pieces)	Washington
Three piece installation (joint in each wall)	Wyoming
Two U-shaped sections placed to form a box	Florida, Texas
Single U-shaped section with a flat slab top	Florida, Ohio, Texas

There are many advantages to using precast box culverts. The rapid installation of precast culverts reduces overall construction time. This minimizes any associated traffic disruptions and reduces the cost of maintenance and protection of traffic. The precast units are manufactured in a controlled environment by experienced labor and in conditions that are not affected by the weather resulting in a better quality concrete product. Plus, fabrication can be easily monitored by the inspection staff. A precast installation procedure is much easier due to the economy resulting from the elimination of most formwork and the need for only a small construction crew. The design and approval time for states who utilize a precast box culvert standard is also reduced. Once properly waterproofed, the precast structure is practically maintenance free. Additionally, the precast option may fit some contractor's grading operations better than cast-in-place resulting in lower overall project bids. Plus, precast is good for projects in rural areas where the batch plant may be located miles away.

Precast box culverts have also incurred some problems. There have been numerous issues surrounding poor alignment and joint fit-up of the box sections in the field. This may be a result of poor installation workmanship, damage to units during shipment and/or installation, inadequate placement of joint material or poor fabrication of the units in the plant. Poor fit-up between sections can lead to leakage and settlement of the precast box culvert and overlaying pavement. Additionally, appearance problems due to poor fit-up can lead to maintenance problems in the future. Design issues have been related to inadequate design loads on excessive fill heights and problems with inadequately detailed pipe inlets. Also, there was some undermining of wingwalls that were placed on a crushed stone base, but the practice is no longer used.

As a result of past problems, some state have incorporated particular requirements into their specifications. Illinois requires every joint to contain mastic and be wrapped with geotechnical fabric. Kansas requires units to be joined in the fabrication plant for inspection of joint fit-up and alignment of boxes; and, a mechanical connection or a partial backfill is required between the boxes of a multiple cell installation prior to grouting. Louisiana sometimes requires a concrete working table for culverts having a

rise greater than 6' due to settlement. New York specifies a waterproof membrane to cover the joints and prevent water leakage. South Dakota requires that inlet and outlet walls be specified on all drainage crossing type precast boxes to prevent piping, erosion, and settlement. Washington requires crack control calculations in addition to the usual strength checks for three-sided structures; and, epoxy coated bars or increased concrete cover is required if the structure does not have much soil cover. As a part of the fabrication process in Wyoming, the fabricator must assemble at least three sections chosen by the quality control inspector. The fit shall meet the same requirements as specified for the final assembly.

Aside from designing the precast box culvert according to AASHTO/ASTM Standards, there are other things that some states consider important for a good precast box culvert design. Kansas limits the precast box member thickness to not less than $\frac{3}{4}$ the thickness of the corresponding member of an equivalent standard cast-in-place culvert. Nevada believes that junction boxes or connections to laterals are best constructed with cast-in-place concrete with precast continuing on either side. Virginia believes that a good design is adequately designed, has an esthetic method of finishing the ends so that the structure looks good, and is installed with minimal joint openings, adequately sealed to prevent infiltration. Washington wants to see emphasis on crack control and concrete cover requirements in a design. None of the states questioned recall any major failures of precast box culverts. Many of the states believe that the possibility of ground failure always exists, but with proper site investigation, design, construction, installation, and inspection of these precast box culverts, the probability is very low.

5.4 State Specification/Detail Summary

Most of the states who responded to the survey maintain a set of precast box culvert specifications, while only some maintain standard details. Although each specification and standard is unique to each state, most contain similar information pertaining to the construction and installation of precast box culverts. The following will summarize the important parts of the specification and details.

Minnesota, Mississippi, Oregon, Tennessee, and Texas all contain a table in the detail drawings indicating culvert size, fill height range, slab and wall thickness, and reinforcement area requirements. The table is convenient because it allows the designer/precaster to select the box culvert's span and rise, and the rest of the information is already figured into the table. If the culvert size is not indicated in the tables, the design is usually considered "special" and must be approved through the State Structures Office. Some other states just indicate a minimum wall and slab thickness as well as maximum fill heights. Kansas, Minnesota, and Pennsylvania require a distribution slab (i.e. a 6" slab with #13 bars at 18" transversely and #16 bars at 12" longitudinally) if the fill height is less than 2'. For concrete cover over the reinforcement, most states follow the ASTM C 1433 requirements. But some states, like Ohio, Kansas, Minnesota, and New Jersey have different requirements for concrete cover. In addition, Kansas, New Jersey, and New York have different corrosion protection requirements for the reinforcing steel used in the top mat of the top slab. Table 5.3 indicates each states requirements for concrete cover.

All of the states require an approved preformed mastic, butyl rubber gasket or bituminous type compound joint filler between the joints of each precast section. And, most states require an external sealing band or strip of geotextile filter fabric approximately 2' wide centered over the joints to prevent the infiltration of any backfill material into the culvert. Kansas and New York have a maximum tolerable gap between sections of 3/4". In addition to the joint materials, some states require that the precast sections be mechanically tied together. One District in Illinois insists on leaving the come-a-long threaded bars in place; however, the rest of the state has had success without using this measure. Minnesota ties individual section together with 1" diameter concrete pipe ties. New Jersey and South Dakota tie their precast units together with a minimum of 4 longitudinal rods or strands. And some contracts in New York require that the mechanical connectors used to draw the sections together be left in place. Also, New Jersey and Ohio are requiring that the boxes be completely waterproofed with the use additional epoxy waterproofing sealer on the exterior of the boxes.

Table 5.3: Concrete Cover Requirements

State	Less than 2' of fill	Greater than 2' of fill
Florida, Illinois, Mississippi, Nevada, New York, South Dakota, Tennessee, Texas	2" for top exterior slab & 1" for remaining covers	1" for all covers
Kansas	2 1/2" for top exterior slab & 1 1/3" for remaining covers	1 1/3" for all covers
Minnesota	1 1/2" min. & 2" max for all covers	1 1/2" min. & 2" max. for all covers
New Jersey	2" for top exterior slab & 1 1/2" for all remaining covers	2" for exterior top slab & 1 1/2" for all remaining covers
Pennsylvania	2" cover for top of top and bottom slab and 1 1/2" for all remaining covers	2" cover for top of bottom slab and 1 1/2" on all remaining covers

As for the bedding/foundation requirements, most states require a minimum of 6" of granular fill placed directly below the box and a minimum of 12-24" extended beyond the exterior sides of the box. Every state installs multiple cell units differently. The nominal space between the sections prior to backfill ranges from 3-24". And the fill material varies from flowable fill grout, sand, pea rock, and crushed stone. All states require that the boxes be partially backfilled or mechanically connected prior to filling the gap. A few states such as Kansas and New Hampshire indicate in the specifications exactly what should be included in the shop drawings. Kansas requires details of all phases of construction, layout, joint details, lifting devices, casting methods, construction placement, details of any cast-in-place segments or required transitions, weights of the precast section, and proposed transportation methods. Finally, some states have specific limitation. In Illinois, the maximum span and rise is 12' and the minimum fill height is 6". In New Jersey, precast box culverts are not used when the top slab is used as a riding surface. And in South Dakota, the minimum length of a precast section is 4' and dry casting is not allowed.

CHAPTER 6 CONCLUSIONS AND RECOMMENDATIONS

6.1 Summary

The purpose of this research was to identify the types and overall performance of precast box culvert systems by surveying the FDOT Districts and other states in the United States. Based on the state survey responses, there has been a very long and good history associated with cast-in-place box culverts. And where there has been trouble in the past with cast-in-place, the problems have occurred at the joints. Precast box culverts have only been around for the past 10-25 years; therefore, questions are being raised concerning their long term performance as suitable and dependable box culvert structures considering the number of joints incorporated into each installation.

The following provides a summary of the information obtained in the literature review (Chapter 2):

- Precast culverts have a quick installation time, reducing environmental and traffic impact.
- The inspected precast culverts are currently in good working condition and no major failures have been recorded.
- Joint leakage seems to be the most predominant problem associated with precast culverts.
- A filter fabric wrap should be required on the tops and sides of the joints to prevent soil infiltration into the culvert.
- Scour of the culvert inlets and outlets can be prevented with the use of filter material and appropriately sized rock riprap.
- The ASTM C 850 design is conservative and relative deflections in adjacent sections, without shear connectors, is insignificant at the design service wheel loads.
- In three-sided precast concrete arch culvert installations, significant load is transferred across a grouted keyway joint in the absence of shear connectors; however, the use of a grouted keyway joint is not seen in practice.
- The field performance of precast concrete arch culverts correlates with the CANDE finite element analysis program.

- As concluded in Beach 1988, the precast concrete arch culvert greatly exceeds all performance requirements for highway loading by sustaining a load greater than five times the HS20 design load without impact.

The following summarizes the responses received from the FDOT District survey. Most of the Districts in Florida have only been using precast for the past 6-12 years. However, the use of precast for new box culvert installations varies from 0-95% around the state. The main advantage of precast over cast-in-place box culverts is the quick installation time reducing the overall construction time. But, there are problems with joints that do not mate properly, sections that are damaged, and insufficient concrete cover over the reinforcement. In addition, there is no requirement on joint tightness in the FDOT Specification and District 5 comments that the ASTM requirements are not enforced by the inspectors. However, Districts 1, 2, 3, and 4 do not indicate any problems thus far with precast box culverts. Most Districts detail the box culverts as cast-in-place on the plans and allow the contractor the option to use precast. District 3 details precast in the plans approximately 5% of the time, mostly when the project impacts the traveling public.

Precast box culvert types used by all Districts are square and rectangular single and multiple cell box units. And, all except District 4 deal with cast-in-place end components. District 4 mostly uses precast wingwalls and toewalls with headwalls being either precast or cast-in-place. There have not been any major failures of precast box culverts and none of the Districts seem too worried about the possibility of failure due to the discontinuity and the large number of joints involved in a precast installation. District 3 suggests that the precast sections be post-tensioned together after installation. All of the Districts seem positive about the possibility of a precast box culvert standard in the state of Florida. The standards would be helpful to the contractors and reduce or eliminate the need for shop drawing reviews. The three precast box culverts that were inspected in Tallahassee all appeared to be in average working condition. Some problems encountered involve exposed and corroded reinforcing steel, the absence of

essential joint filler, RAM-NEK®, material, and sinkhole developments over the precast structure where overlaying earth has seeped through the joints of the culvert sections.

The following summarizes the survey sent to each state in the continental United States. Six different types of precast culverts were identified as being used by different states. Although most states seemed to only utilize the 4-sided single and double cell box culverts, a few states indicated some use of the 3-sided U-shaped and CON/SPAN structures having reported no major problems. Many states maintain specifications that allow contractors the option of using precast instead of cast-in-place. Many states require that the end components are constructed as cast-in-place structures; however, some states are already heading in the direction of precast wingwalls and headwalls. The use of precast box culverts was prompted by the incredibly quick installation time keeping interference with daily traffic flow to a minimum. This continues to be the major advantage of precast over cast-in-place box culverts; however, other advantages include ease of installation, reduction in cost of maintenance and protection of traffic, and controlled fabrication resulting in improved concrete quality.

The problems associated with precast box culverts include poor alignment and joint fit-up, inadequate designs, pipe inlet requirements, and damage to units during shipping and installation. Because poor joint fit-up between sections can lead to settlement of the overlaying pavement and cause a major failure, joints are an important link in the precast box culvert system. All states require some form of a rubber preformed mastic joint filler in between each section and a filter fabric covering each joint to prevent earth infiltration into the culvert. A few states also require a waterproofing membrane to prevent water from entering into the culvert through the joints. And, a handful of states actually require the precast sections to be tied together with longitudinal rods to ensure that the sections do not separate.

6.2 Conclusions

Precast box culverts have been around for the last 25 years, but usage has really only picked up in the last 10 years. The use of precast box culverts was prompted by

their quick installation time and increased concrete quality over their cast-in-place counterpart. However as with any new product, problems were encountered during the design, construction, and installation processes. Due to transportation, weight, and lifting requirements, precast sections are limited to 6-8' lengths, requiring a numerous amount of joints in every precast box culvert installation. Therefore, most of the installation and performance problems involve the joints. But, most states who reported joint fit-up problems with precast box culverts seem to have resolved their issues and are satisfied with the current construction and installation of their precast box culvert systems.

The knowledge and experience with precast box culverts seemed to vary throughout the states who responded to the survey. A few states, with a high percentage of precast box culverts being installed, maintain design, construction, and installation specifications and standardized details, while others, who can only recall the installation of one precast box culvert in their entire state, have no specifications or details. Because box culverts are not considered bridges, they are not periodically inspected, accurately inventoried, nor intensely studied to determine their actual field performance. And, most states do not have standardized details for precast box culverts. Due to the lack of standardization and limited knowledge of the long term field performance of precast box culverts, some states may be uncertain and weary of their widespread use. Overall, the states who are using precast box culverts report no major failures and believe that their precast box culverts are a good product. Although many believe that the possibility of failure does exist, with the proper site investigation, design, construction, installation, and inspection of these precast box culverts, the probability of failure should remain very low.

6.3 Recommendations

None of the states surveyed reported any major failures and all were very positive about precast box culverts, recommending their future use. Therefore, it is recommended to continue design, construction, and installation of 4-sided single and multiple cell precast box culverts. Other systems may be appropriately permitted; however, they have not been used as extensively as the 4-sided box culverts. Although the Florida

Department of Transportation wanted to see examples of both good and bad details, none of the states surveyed had any examples of bad details. This is probably because there have not been many failures due to improper design. Most of the problems that states had with precast box culverts dealt with the construction and installation, as opposed to the actual design of the culvert.

The joints connecting the precast sections seemed to be the biggest issue and concern of the states surveyed. Most problems that states have encountered have been centered around the joint fit-up or the actual joint materials. Most of the states mentioned joint “fit-up” problems leading to soil infiltration and settlement. Illinois, Kansas, and Wyoming all seemed to solve this problem by visiting their respective fabrication plants and requiring units to be joined in the plant for inspection of joint fit-up and box alignment. It is recommended that Florida should review their plant inspection process to ensure that the precast box sections are being properly inspected for joint fit-up and alignment in the fabrication plant. Also, some states, such as Nevada, New York, and Virginia, require that the maximum tolerable gap between the box sections is $\frac{3}{4}$ ”; therefore, it is recommended that this tolerance be added to the FDOT specification. Also, Minnesota, New Jersey, and South Dakota, require that the precast sections be mechanically tied together to ensure continuity. Because the states who use tongue and groove joints without mechanically tying the precast sections together have had success, it is not recommended that Florida mechanically connect the precast sections together.

Most states have modified their joint policy to require joint filler material and a geotechnical filter fabric at each joint. Plus, some states have also added a waterproofing membrane over the exterior joints to further waterproof the structure and prevent leaky joints. Joint material problems were noted in the existing precast culverts visited in Tallahassee. The RAM-NEK® material used on the projects did not seem to be working correctly. Furthermore, it was discovered while talking with FDOT District 4 that this RAM-NEK® material is not even an approved joint filler material in the state of Florida. But because there are not any joint filler materials approved in the state of Florida, the RAM-NEK® material is often used. Therefore, it is recommended that research be

conducted to approve a joint filler material that will appropriately seal the joints between the sections. Geotechnical filter fabric is essential in every box culvert installation to prevent the infiltration of backfill into the culvert; however, it must be properly secured against the box sections to serve its purpose. It is recommended to continue wrapping each joint with filter fabric with further investigation into its actual application to ensure proper installation. In addition to the joint filler and filter fabric, New Jersey, New York and Ohio require that a waterproofing membrane be applied to the top and sides of the structure. This further protects the culvert against leaky joints. If Florida is concerned with leaky joints, it is recommended that a similar waterproofing membrane be required in addition to the joint filler and filter fabric.

Because these box culverts are not considered bridges, many states, including Florida, do not maintain a detailed inventory or conduct periodic inspections of any box culverts with spans less than 10'-20'. For the most part, it seems that culverts are installed as either a cast-in-place or precast structure, inspected, and then forgotten about. Without an inventory of the precast box culverts, there is no way to monitor their progress and field performance in comparison to their cast-in-place counterpart. How can performance be determined without knowledge of pertinent culvert data, especially location? Therefore, it is recommended that the FDOT develop and implement an inventory tracking database of all precast culvert installations to include culvert type, size, location, installation date, and manufacturer. Currently, box culverts are not required to have any post installation inspections. And due to the lack of an inventory and the large number of box culverts installed in Florida, it would be virtually impossible to require periodic inspections of all box culverts. Consequently, it is recommended that the FDOT visually document the final inspection for future reference.

In addition, most states, including Florida, review shop drawing designs submitted by the precasters because they do not maintain standards for precast box culverts. FDOT District 4 indicated that some details submitted by the precasters are more detailed than others, possibly resulting in better construction and installation of the precast box culverts. Therefore, it is recommended that shop drawings be required to

include fully detailed box sections, details of all phases of construction, layout, joint details and protection requirements, lifting methods and devices, casting methods, construction placement, details of any cast-in-place or precast segments, required transitions or tie-ins, weights of the precast sections, and the proposed transportation methods.

And although the FDOT Specification Section 410 for precast concrete box culverts covers important installation guidelines, some sections are a little vague using the words, “or as detailed on the plans.” If some shop drawings are not very detailed and the specifications are vague, then contractor’s do not have many requirements to follow which may result in non-uniform construction and installation of all precast box culverts. As a result, it is recommended that FDOT Specifications Section 410 be reviewed and revised accordingly. As for a joint sealer, Section 410 only indicates requirements for a butyl rubber based preformed plastic gasket material without addressing any physical requirements of the material or application requirements for use with a precast box culvert installation. The filter fabric requirements do not address application locations or methods. Additionally, multiple cell installations, plant inspection requirements, and culvert inspection tolerance are not addressed. Of all of the states to submit standard specifications, Kansas was believed to be the most detailed, thoroughly addressing relevant material and installation requirements. Please refer to www.ksdot.org (password is required) or Appendix F for Kansas’ specifications.

Finally, some of the states surveyed had a set of standard specifications and drawings for precast box culverts, eliminating the need for submitting and reviewing most shop drawings. All of the FDOT Districts seemed positive about the possibility of developing a set of standard details. It is recommended that Florida research the possibility of developing a set of standard details for single and multiple cell precast box culvert installations that fully detail the boxes, provide joint dimensions, joint protection requirements, detail the typical end components (headwalls, wingwalls, toewalls, bends in the box, and tie-ins), give guidelines for future extensions to existing culverts, etc.

6.4 Summary of Recommendations

As a result of this study, the following things are recommended to the Florida Department of Transportation.

- Continue design, construction, and installation of 4-sided single and multiple cell precast box culverts. Other systems may be permitted; however, they have not been used as extensively as the 4-sided box culverts.
- Review the FDOT's plant inspection process to ensure that the precast box sections are being properly inspected for joint fit-up and alignment in the fabrication plant.
- Research and approve a joint filler material that will appropriately seal the joints between the sections.
- Continue to completely wrap the top and sides of each joint with geotextile filter fabric with further investigation into its proper installation.
- If the FDOT is concerned with leaky joints, require a waterproofing membrane in addition to the joint filler.
- Develop and implement an inventory tracking database of all culvert installations to include culvert type, size, location, installation date, and manufacturer.
- Develop and implement a guideline requiring all final culvert inspections be visually documented.
- Revise the FDOT Specification Section 410 to include:
 - Requirements for shop drawings to include fully detailed box sections, details of all phases of construction, layout, joint details and protection requirements, lifting methods and devices, casting methods, construction placement, details of any cast-in-place or precast segments, transitions or tie-ins that are required, weights of the precast sections, and the proposed transportation methods
 - A section indicating the plant inspection criteria and permissible tolerances
 - A section indicating all material standards and requirements
 - A maximum tolerable gap of $\frac{3}{4}$ " between each precast section
 - Joint section 410-4 to include approved joint and filter fabric materials or required physical requirements with appropriate application methods, locations, and sizes

- A section on multiple cell culvert installations to include the maximum permissible longitudinal gap between adjacent sections and the appropriate joint material
- Consider the possibility of developing a set of standard details for single and multiple cell precast box culvert installations that fully detail the boxes, provide joint dimensions, joint protection requirements, detail the typical end components (headwalls, wingwalls, toewalls, bends in the box, and tie-ins), give guidelines for future extensions to existing culverts, etc.

REFERENCES

- Beach, Timothy J., "Load Test Report and Evaluation of a Precast Concrete Arch Culvert," Transportation Research Record 1191, Transportation Research Board, National Research Council, Washington D.C., 1988, pp.12-21
- Carfagno, Michael G., Vala, Lynne A., and Evans, Kristi, "Brush Creek Improvements: Double Cell Arch Culvert Installation in Prairie Village, Kansas," Transportation Research Record 1594, Transportation Research Board, National Research Council, Washington D.C., 1997, pp. 194-199
- Hicks, Tyson and Kitchen, Steve, "Twin Cell Precast Concrete Box Culvert Minimizes Environmental Impact," Concrete Pipe News, Fall 2001, pp. 5-6
- Hicks, Tyson, "Reinforced Concrete Box Culvert System Solves Ten-Year Drainage Problem," Concrete Pipe News, Spring 2001, pp. 5-7
- Hill, James J., "Construction and Field Evaluation of Precast Concrete Arch Structures" Transportation Research Record 1008, Transportation Research Board, National Research Council, Washington D.C., 1985, pp. 94-104
- Hill, James J., and Laumann, Floyd J., "First Precast Concrete Box Culverts in Minnesota," Transportation Research Record 1514, Transportation Research Board, National Research Council, Washington D.C., 1995, pp. 22-28
- Hurd, John Owen, "Field Performance of Precast Reinforced Concrete Box Culverts," Transportation Research Record 1315, Transportation Research Board, National Research Council, Washington D.C., 1991, pp. 53-57
- Hurd, John Owen, "Research Pays Off: Eliminating Shear Connectors Slashes Culvert Cost," TR News September-October 1988, pp.14-15

James, Ray W., "Behavior of ASTM C 850 Concrete Box Culverts Without Shear Connectors," Transportation Research Record 1001, Transportation Research Board, National Research Council, Washington D.C., 1984, pp. 104-111

Little, Bryan E., Mize, Theodore A., and Bailey, Robert J., "Evaluation of Shear Plates and Grouted Shear Key Joint Performance of a Three-Sided Precast Culvert," Transportation Research Record 1315, Transportation Research Board, National Research Council, Washington D.C., 1991, pp. 194-199

McGrath, Timothy J., Selig, Ernest T., and Beach, Timothy J., "Structural Behavior of Three-Sided Arch Span Bridge," Transportation Research Record 1541, Transportation Research Board, National Research Council, Washington D.C., 1996, pp. 112-119

Musser, Samuel C., "A Synthesis of the Application and Performance of Three-Sided Precast Box Culverts," Transportation Research Board, 74th Annual Meeting, February 1995, Paper No. 951091

APPENDIX

APPENDIX A FLORIDA DISTRICT CONTACT LIST

DISTRICT	CONTACT NAME	POSITION	PHONE	SUNCOM	FAX	EMAIL ADDRESS
1	Billy	Maintenance Engineer?	(941) 656-7850		(941) 656-7737	
2	John Tung	Bridge Structural Engineer	(386) 961-7000	862-7000	(386) 961-7095	john.tung@dot.state.fl.us
3	Keith Shores	Structures Design Engineer	(850) 638-0250	767-1449	(850) 638-6148	keith.shores@dot.state.fl.us
4	Geoffrey Parker	Structural Design Engineer	(954) 777-4647	436-4647	(954) 777-4634	geoffrey.parker@dot.state.fl.us
5	Shinji Konno	Structures Engineer	(386) 943-5416	373-5416	(386) 736-5456	shinji.konno@dot.state.fl.us
6	Maria Carasa					maria.carasa@dot.state.fl.us
7	David Pelham	Structures Engineer	(813) 975-6771	512-7976	(813)975-6150	david.pelham@dot.state.fl.us

APPENDIX B FLORIDA DISTRICT SURVEY MATRIX

District	Years of use?	Frequency of use for new installations?	Frequency of use for extensions?	Advantages?	Problems / Disadvantages?	Types used?	When do you decide to use precast as opposed to CIP? Or does the Contractor decide?	If District predominately uses CIP - Why?	How do you deal with Headwalls / Endwalls / Wingwalls?	What things do you look for when reviewing a box culvert design submitted by a precaster?	What makes for a good design?	What makes for a bad design?	Would you like to see the state of Florida develop standard details for precast box culverts? What exactly might you want out of a standard?	Failures and/or do you worry about the possibility of failure due to the discontinuity and the number of joints?	Personal Opinion?
1	10-12 years	About 10%	About 2%	construction is much faster	No problems	square and rectangular - single and double barrel	It is the contractors option	NA	All CIP	Person who responded to the survey does not review the design	NA	NA	NA	No known failures	Thinks that precast box culverts are good, if they are constructed properly
2	1993 - 1 1994 - 1 1995 - 2 1998 - 1 2001 - 1 2002 - 2 The quantities measured only pertain to culverts measuring more than 20' wide - no idea the number of 'non-bridge' culverts in the district	9 out 255 box culverts are precast - about 3.5%	Have 2 precast box culvert extensions in inventory	The good thing about box culverts, either CIP or precast, is that they are cheaper to build in comparison to the regular bridge. The shorter construction time would be the advantage of the precast culvert	The common problems in our CIP culverts are deterioration at the construction joints between the wall (web) and the floor. The undermining at the toe or wingwalls are also common. Some of our older CIP box culvert walls have been repaired due to badly deteriorated concrete and reinforcing steel. All of our precast culverts are relatively new and have no problems so far.	The quantities measured in the first questions only pertain to culverts measuring more than 20' wide - all are multiple cell installation.	Usually show CIP in the new designs but give the contractors the option to use precast per FDOT Standard Specification	The main concern of designers in designing the precast culverts are the possible joint leakage or failure due to differential settlements. The cost factor may be the reason for contractor not choosing precast. Contractors are required to hire a specialty engineer to design and submit to the Department for approval at the contractor's expense. The saving, if any, of precast may not be that great as a result. One of the designers cited that the CIP culvert program is readily available and easy to use.	CIP is probably more practical As for the wingwalls, would like to see stand alone because it is easier to repair when and if it fails. Yes, there were cases of undermining at the wingwall toe walls before. Mechanical connectors will more likely have maintenance problems later because of corrosion.	I would look at the design from the maintenance point of view, especially the joint detail and concrete mix which may lead to future maintenance problems	One which takes into consideration off all the site specific information, such as soil and hydraulic conditions at the site. One of the misconceptions people inherited from "standard design" is "one size fits all". Clearly specify in the "standard design" the assumptions made when arriving at the standard. For example, how far the toewalls should be extended below the box culvert's floor at each end of the culvert to prevent undermining will depend on the soil and hydraulic conditions at the location, unless appropriate scour countermeasures are taken	If one of the problems was found after it was built, then it would be a bad design	Yes, but it may be difficult to come up with standard details for the reasons indicated in previous questions. You may want to develop some design "example details" instead of "standard details" and let the designer choose the details best fit for their specific site conditions	All our precast culverts are relatively new and there have been no failures so far. Apparently, the weakest link in the precast culverts would be the joints. Failure, if happened, would occur at the joints	From time saving point of view, precast culverts have definite advantages over CIP. It is possible that, if popularity of precast culverts increases, the supplier may start to stock pile the standard" size boxes and keep costs low
3	Not sure how long	About 95% are detailed as CIP - from that roughly 10-20% are precast	About 95% are detailed as CIP - from that roughly 10-20% are precast	Not aware of any	Not aware of any	Don't know	On occasion, we specify that the contractor use a precast culvert because of impacts to the traveling public. Probably 95% of the time we design and show CIP in the plans. Section 410 of the Specification allows the contractor to use the precast option in lieu of CIP method	Not really sure. Section 410 was only added to the Specifications about 5 years ago. Maybe the lack of knowledge by the designers or lack of standard details...	I believe that these are all CIP and tied to the precast units. Believes that the wingwalls are all attached - not aware of any failures	That it meets or exceeds the specification, designed to the right standards, concrete cover, concrete class, etc.	Don't know	Don't know	Yes. Maybe something similar to the CIP standards and a program which will design the box	I don't know of any failures, but yes the possibility of failure is a concern. Maybe the units could be post tensioned together after installation?	
4	Been around for about 20 years - use has really stepped up in the past 6-7 years	About 95-99%	About 75%	Quick installation time - reduces actual construction time	issue of mechanical connection between the barrel and wingwalls - any slight movement of the wingwall could cause infiltration and failure	square and rectangular - single and multiple barrel	Specify CIP and the contractor decides - chooses precast about 99% of the time	NA	Wingwalls seem to mostly be precast. Headwalls and Toewalls either CIP or precast - better idea for toewalls to be CIP due to transportation and installation concerns - failure of wingwall that was not connected to the barrel	Geometric and hydraulic controls - box opening span/height, wall thickness and slab thickness. And look to see that the reinforcing is equal to or greater than the reinforcing called for in the original plans. And look at the connecting details, wingwalls, etc.	Very good details prepared by the precaster indicating filter/geotech fabric, pick-up points, compressed joint material, pipe openings, good connections between the headwall/toewall and the barrel	Bad design is very vague with insufficient details	Yes, we want a standard that will eliminate the need for a design of box culverts in over 60% of all culvert installations. In addition, we want a standard which will normalize installation procedures to provide a product of quality and durability.	No visible signs of piping failures or potholes, etc. Not worried about failure due to number of joints.	There are also many joints associated with CIP box culverts - all comes down to proper installation (structures and construction issue)

APPENDIX B FLORIDA DISTRICT SURVEY MATRIX

District	Years of use?	Frequency of use for new installations?	Frequency of use for extensions?	Advantages?	Problems / Disadvantages?	Types used?	When do you decide to use precast as opposed to CIP? Or does the Contractor decide?	If District predominately uses CIP - Why?	How do you deal with Headwalls / Endwalls / Wingwalls?	What things do you look for when reviewing a box culvert design submitted by a precaster?	What makes for a good design?	What makes for a bad design?	Would you like to see the state of Florida develop standard details for precast box culverts? What exactly might you want out of a standard?	Failures and/or do you worry about the possibility of failure due to the discontinuity and the number of joints?	Personal Opinion?
5	At least since 1991- prior to the development of "Jerry Potter's Specifications ." precast was proposed by the contractors using ASTM spec. for both new culverts and extensions. But, no precast proposals in the past two years.	0% for the past two years	0% for the past two years	The precast box culverts are constructed relatively quickly compared to CIP. The contractor can save construction time by using precast box culverts. The contractor does not subs to place the formwork and steel.	No requirement on joint tightness in our specifications. ASTM requirements are not enforced by the inspectors since they don't have the ASTM specifications. Sometimes the sidewalls are not straight and segments are not match-cast, so they don't fit well. It is difficult to place cells side by side and maintain straightness.	square and rectangular - single barrel and one instance where three single cells were placed to form a triple barrel - concern with longitudinal joints between the cells. Difficulty placing the cells side by side and fines were getting into joints and ended up pouring flowable fill between the cells.	Usually, specify CIP and the contractor can propose a precast alternative. Maybe one or two projects where the consultant specified a precast box culvert on the contract plans, however, FDOT never received the shop drawing	Told that precast box culverts were not structurally equivalent to the CIP box culverts. Concerned with leakage from the joints. And the headwalls and end details must be developed by another precaster, so the contractor usually stays the precast option (cost add'l money to hire a specialty engineer to design the connection details)	Don't think there were any precast wingwalls. The headwalls are usually CIP. We had a wingwall failure one or two years ago. This was not related to the precast box culverts. If you don't connect the wingwalls to the main box, there is a possibility that the walls could fail during the construction (saturated ground during rain) unless the walls are braced properly and no hydrostatic pressure built up behind the walls.	The submittal must be equivalent to CIP in reinforcing steel and dimensions. The headwalls and connection details are provided in the submittal. The epoxy must be put on each face of segments to create water-tightness and adequate wrapping with filter fabric must be done.	Department uses a LFD box culvert design program and a LRFD box culvert design program (mathcad file) - Designed many culverts in house. It is difficult to have a bad design using the LFD box culvert program, but you must have experienced engineers designing structures on FDOT projects. Very large skewed ends are always difficult to detail and construct. The LFD program has height restrictions, so culvert can't be too tall.		If we can resolve the water tightness and settlement issues, it will be helpful for the contractor to use the precast box culverts. We also need to resolve the difference between the ASTM specifications and the Department's design requirements.	The structural engineers always consider the possibility of failure, and we try to identify and adequately deal with the problems	On skewed culverts you still need to CIP and the detailing the connection is really important. You also need experienced engineers designing these structures. There also has to be a provision for future lengthening (extensions) on culverts.
6	Do not use precast	0%	0%	Not given	Not given	NA	Normally, CIP is specified, but the contractor can propose a precast alternative to be evaluated	CIP seems to be a better product, most adaptable to geometry with inflections in alignment and widening of older culverts.	Normally deal with CIP end components - believe that wingwalls should be mechanically connected	Bedding preparation, joint adequacy, and constructability	Not given	When there is no flexibility	Could be used for straight alignments - would want flexibility of sections for different loading	Discontinuity will be critical when there is differential settlement	Strength of joints is critical for maintaining the correct alignment
7	Believe that the first precast box culvert was built around 1994	About 75%	Less than 50%	Some advantages because they can be constructed under shop conditions with presumably better control than job site conditions. Plus, the construction at the jobsite is quicker, thus potentially reducing the time of lane closures at some locations.	Some problems with joints that do not mate properly or have been damaged and reinforcement with insufficient cover.	square and rectangular - single and multi-barrel	Specify and detail CIP in the plans, but our specifications allow the contractor to provide a precast alternative - Contractor must submit shop drawings if opts to use precast. Some circumstances when CIP is specified but precast is not allowed - high embankments or adjacent to mechanically stabilized earth walls.	NA	Wingwalls, headwalls, and toe walls are generally CIP. Wingwalls should be mechanically attached to the barrel - not aware of any failures.	1. Do hydraulic opening sizes match the original plan? 2. Does the design meet AAHSTO/FDOT requirements 3. Are the concrete class and reinforcement cover adequate? 4. Are the joints completely detailed (including joint sealers and filter fabric)? 5. Are openings for pipes, inlets, etc. shown and detailed? 6. Are CIP components fully detailed? 7. Are the plans and calcs signed and sealed by a Florida PE.	Good design addresses all the items listed to the left.	Contractors have submitted shop drawings with insufficient details, particularly of CIP components such as headwalls, wingwalls, bends in the box culverts and ties-ins to existing structures	Would like to see FDOT develop standard details for precast box culverts. Plans should fully detail the boxes and provide joint dimensions and protection requirements and detail typical CIP components (headwalls, wingwalls, bends in the box, and tie-ins). Standard drawings should be sufficient to minimize or eliminate the need for shop drawings during construction	Not aware of any "major" failures, but there have been instances of joint gasket material separating from the joints. Are concerned about the long-term effect of the large number of joints and the possible loss of fill material through the joints if the boxes are not fabricated and installed properly	Although they have some advantages, additional work is needed to ensure the integrity of these structures is maintained. Standard drawings prepared after consultation with precasters and contractors may help alleviate these concerns.

APPENDIX C STATE CONTACT LIST

STATE	CONTACT NAME	PHONE	MAILING ADDRESS	EMAIL ADDRESS	DOT WEB ADDRESS	RESPONSE
Alabama	William Conway		1409 Coliseum Blvd. Montgomery, AL 36130		www.dot.state.al.us	NO
Arizona	P. Yang		205 S. 17th Ave. Phoenix, AZ 85007	pyang@dot.state.az.us	www.dot.state.az.us	YES
Arkansas	Edward Fain		PO Box 2261 Little Rock, AR 72203		www.ahrd.state.ar.us	NO
California	James Roberts		PO Box 942874 Sacramento, CA 94274-0001		www.dot.ca.gov	NO
Colorado	Michael McMullen		4201 E. Arkansas Ave. Denver, CO 80222	michael.mcmullen@dot.state.co.us	www.dot.state.co.us	YES
Connecticut	Gordon Barton		PO Box 317546 Newington, CN 06131-7546		www.state.ct.us/dot	NO
Delaware	Dennis O'Shea	(302) 760-2299	PO Box 778 Dover, DE 19903	doshea@mail.dot.state.de.us	www.dot.state.de.us	YES
Georgia	Paul Liles	(404) 656-5280	No. 2 Capitol Square Atlanta, GA 30334-1002	paul.liles@dot.state.ga.us	www.dot.state.ga.us	YES
Idaho	Matthew Farrar		PO Box 7129 Boise, Idaho 83707		www2.state.id.us/itd/index	NO
Illinois	Kevin L. Riechers	(217) 782-9109	2300 S. Dirksen Parkway Springfield, IL 62764	riecherskl@nt.dot.state.il.us	www.dot.state.il.us	YES
Indiana	Mary Jo Hamman		100 N. Senate Ave. Indianapolis, IN 46204-2216		www.in.gov/dot	NO
Iowa	Sandra Larson		800 Lincoln Way Ames, IO 50010		www.dot.state.ia.us	NO
Kansas	Richard Mesloh	(785) 368-7175	Bureau of Design, 9th Floor, Docking State Office Bldg. Topeka, KS 66612-1568	mesloh@ksdot.org	www.ksdot.org	YES
Kentucky	Stephen Goodpastor		State Office Bldg., 7th Floor, High & Clinton St. Frankfort, KY 40622		www.kytc.state.ky.us	NO
Louisiana	William Ray	(225) 379-1336	Section 24 Hydraulics PO Box 94245 Baton Rouge, LA 70804-9245	wray@dotd.state.la.us	www.dotd.state.la.us	YES
Maine	James Tukey		State Office Bldg. Augusta, ME		www.state.me.us/mdot	NO
Maryland	Earle Freedman		707 N. Calvert Street Baltimore, MD 21202		www.mdot.state.md.us	NO
Massachusetts	Alexander Bardow		10 Park Plaza Boston, MA 02116-3973		www.magnet.state.ma.us/mhd	NO
Michigan	Mark Van Port Fleet		PO Box 30050 Lansing, MI 48909		www.mdot.state.mi.us	NO
Minnesota	Donald Flemming		1500 W. County Road B2 Roseville, MN 55113-3105		www.dot.state.mn.us	YES
Mississippi	Harry Lee James	(601) 359-7070	PO Box 1850 Jackson, MS 39215-1850	hjames@mdot.state.ms.us	www.mdot.state.ms.us	YES
Missouri	Gregory Sanders	(573) 526-0245	105 W. Capitol Ave. PO Box 270 Jefferson City, MO 65102	sandeg@mail.mdot.state.mo.us	www.mdot.state.mo.us	YES
Montana	William Fullerton		2701 Prospect Ave. Helena, MT		www.mdt.state.mt.us	NO
Nebraska	Lyman Freemon		PO Box 94759 Lincoln, NE 68509-4759		www.dot.state.ne.us	NO
Nevada	Todd Stefanowicz	(775) 888-7550	1263 South Stewart St. Carson City, NV 89712	tstefanowicz@dot.state.nv.us	www.nevadadot.com	YES
New Hampshire	Joseph F. Kieronski		John O. Morton Bldg. Hazen Dr. Concord, NH 03301-0483		www.webster.state.nh.us/dot/	YES
New Jersey	Harry Capers	(609) 530-2457	1035 Parkway Ave. CN 600 Trenton, NJ 08625		www.state.nj.us/transportation/	YES
New Mexico	Jim Camp		PO Box 1149 Santa Fe, NM 87503	jimmy.camp@nmshtd.state.nm.us	www.nmshtd.state.nm.us	YES
New York	Jim Reidy	(518) 457-5956	Materials Bureau, Bldg. 7A, 1220 Washington Ave. Albany, NY 12232	ireidy@qw.dot.state.ny.us	www.dot.state.ny.us	YES
North Carolina	William Rogers		PO Box 25201 Raleigh, NC 27611-5201		www.ncdot.org	NO
North Dakota	Tim Horner		608 E. Boulevard Ave. Bismarck, ND 58505-0700		www.state.nd.us/dot	NO
Ohio	Doug Gruver	(614) 728-4585	1980 W. Broad St. Columbus, OH 43223	doug.gruver@dot.state.oh.us	www.dot.state.oh.us	YES
Oklahoma	Robert Rusch		200 NE 21st St. Oklahoma City, OK 73105-3204		www.okladot.state.ok.us	NO
Oregon	Mark Hirota		329 Transportation Bldg. Salem, OR 97310		www.odot.state.or.us	NO
Pennsylvania	R. Scott Christie		7th Floor, Forum Place, 555 Walnut St. Harrisburg, PA 17101		www.dot.state.pa.us	YES
Rhode Island	Kazem Farhoumand		State Office Bldg. Providence, RI 02903		www.dot.state.ri.us	NO
South Dakota	Kevin Goeden	(605) 773-3285	Becker-Hansen Bldg. 700 E. Broadway Ave. Pierre, SD 57501	kevin.goeden@state.ed.us	www.sddot.com	YES
Tennessee	Houston Walker	(615) 741-5335	505 Deadrick St. Suite 1100 Nashville, TN 37243-0339	houston.walker@state.tn.us	www.tdot.state.tn.us	YES
Texas	Gregg Freeby	(512) 416-2192	125 E. 11th St. Austin, TX 78701	gfreeby@dot.state.tx.us	www.dot.state.tx.us	YES
Utah	P.K. Mohanty		4501 S. 2700 West Salt Lake City, UT 84119		www.sr.ex.state.ut.us	NO
Vermont	Warren Tripp		133 State St. Montpelier, VT 05602		www.central-vt.com/web/vtrans	NO
Virginia	Doug Horton	(804) 786-1315	1401 E. Broad St. Richmond, VA 23219-2000	douglashorton@virginiadot.org	www.virginiadot.org	YES
Washington	Mark Szewcik	(360) 705-7396	PO Box 47340 Olympia, WA 98504-7340	szewcim@wsdot.wa.gov	www.wsdot.wa.gov	YES
West Virginia	James Sothen		1900 Washington St. East Charleston, WV 25305		www.wvdot.com	NO
Wisconsin	Stanley Woods		PO Box 7916 Madison, WI 53707		www.dot.state.wi.us	NO
Wyoming	Gregg Fredrick	(307) 777-4427	PO Box 1708 Cheyenne, WY 82003-1708	gregg.fredrick@dot.state.wy.us	www.wydotweb.state.wy.us	YES

APPENDIX D STATE SURVEY MATRIX

States	Years of use?	Frequency of use?	Advantages?	Problems/Disadvantages?	Types used?	When do you decide to use precast as opposed to CIP? Or does the Contractor decide?	How do you deal with Headwalls / Endwalls / Wingwalls?	What makes for a good design?	What makes for a bad design?	Special Requirements?	Failures?	Personal Opinion?	State Status x - finished	Documents
Arizona					Use Con Span Bridges								x Did not offer help - did not contact	None
Colorado	10 years - as a general allowed substitute 20 years - case by case basis	10% of new box culverts	1. Construction time limits encourage precast	1. No control over what they want or get 2. Lack of knowledge of what is possible, available, appropriate design methods, precisely what was installed 3. Leakage 4. Poor installation workmanship	Square and Rectangular						Reports that they have not been getting many phone calls about major construction problems or post construction failures		x Sent survey and have received two responses Sent additional questions - waiting for a response, but never received response	None
Delaware				Not aware of any problems with Con Span	Used Con Span Bridges in the past and a Bebo arch - 11 years ago						Not aware of any problems to date		x Did not sent survey - did not seem like they would be of any help	None
Georgia	Have had a precast box culvert standard since 1985	Mostly use CIP - precast standard is hardly ever used - about 99% of all culverts are CIP		No particular problems	Square and 3-sided arch - more difficult due to scour	Contractor decides and provides it in accordance with the standard - they generally choose CIP					None	There isn't any problem with precast culverts if they installed correctly	x Sent survey and received a response. Sent additional questions - received a response	None
Illinois	Have been using precast since the early 80's - growing confidence with service life, reliability, and maintenance	In 2001, spent \$5.3M on CIP & \$6.2M on precast box culverts	1. Shorten construction time in the field 2. Allow for traffic to open up sooner 3. Fabricated with experienced labor in conditions that are typically not affected by weather	Biggest problem is the fit-up between sections which can lead to settlement - solved by visiting fabricating plants and making adjustments in their process & changing joint policy	Double & Triple cell boxes and 3-sided structures which can span up to 42' - 48'	1. Encouraged to specify precast when possible 2. Precast not always applicable due to certain geometry configurations 3. Precast not recommended in areas subject to flooding with highly scourable flow line soils, areas w/ excessive settlement, high seismic zone regions, areas w/ "imperfect trench", and where pile foundations are needed	Precast works well for routine projects with little skew, but CIP is usually detailed in the plans	Use AASHTO M 259 and M273 - if there are sections beyond the charts - Use BOXCAR		Modified policy about 3 yrs ago - require mastic at every joint & must wrap every joint with Geotechnical fabric - this and better fab. Have been effective in providing good joints and preventing soil infiltration	No concerns with connections and I'm not aware of any failures... Boxes are typically either pushed or pulled together with a come-a-long system	1. Precast Box Culverts are a good product in Illinois 2. Good communication with fabricator and periodic plant inspections is important 3. Moved toward a QA/QC program	x Sent survey and received a response. Replied asking for documents - received a fax Sent additional questions - received a response	Found Construction Specifications on website & received a fax of the precast portion of the IDOT Culvert Manual
Kansas	Culvert options in the late 1970's - about 25 years	About 10% of total box culverts are precast - only track 10' wide on State system	1. Quick installation Time	1. Problems with boxes not fitting together in the field 2. Large gaps b/t some boxes due to sand getting trapped underneath the boxes	1. Double cell boxes up to 14' spans	Contractor has the option - usually precast is used only when time is the main concern	Require wingwalls and headwalls to be CIP, so many contractors do not opt to use precast	Limit precast box member thickness to not less than 3/4 the thickness of the corresponding member of an equivalent KDOT standard CIP culvert - came about due to relatively thin slabs and large amounts of shear steel that the fabricators were putting in the slabs at high fill locations	1. When multiple cells are set side by side, not as hydraulically efficient due to double interior wall 2. Potential joint problems may occur in settlement of fill 3. Unless minimum fill (or distribution slab) joint loads can be a problem??	1. Require units to be joined in the fabrication plant for inspection of joint fit-up and alignment of boxes 2. Require a mechanical connection b/t boxes or partially backfilling the boxes prior to grouting - for multi-cell installations		Precast Box Culverts provide a viable option to CIP and especially effective when Contractor needs to complete the culvert in a timely fashion	x Sent survey and received a response.	Std. & Construction Specifications & Details
Louisiana	A little over 10 years	No Comment	Reduces construction time and improves quality	Problem with larger culverts (> 6' rise) during installation - a concrete working table is required due to settlement during construction - if settlement does occur, it is very hard to pull joints of structure together at the top	No comment	Normally Contractor decides, but sometimes specified when there is a time constraint	Use "freestanding" CIP headwalls - no mechanical tie is required					Excellent Innovation	x Sent survey and received a response - sent additional questions - have not received a response	None

APPENDIX D STATE SURVEY MATRIX

States	Years of use?	Frequency of use?	Advantages?	Problems/Disadvantages?	Types used?	When do you decide to use precast as opposed to CIP? Or does the Contractor decide?	How do you deal with Headwalls / Endwalls / Wingwalls?	What makes for a good design?	What makes for a bad design?	Special Requirements?	Failures?	Personal Opinion?	State Status x - finished	Documents
Mississippi				Considered culverts not bridges, therefore, not inspected on a routine basis - No data on box culvert performance or associated problems				Sent standard drawings - I assume that they are good?					x Did not send a survey because did not seem like any help	Std. drawings
Missouri	Nearly 15 years	No Comment	Better concrete, better pour, better product	Design Issues - Inadequate design loads on excessive fill heights Problems when a pipe inlet is required	Reinforced concrete pipe & corrugated steel pipe would be good substitutes	1. Contractor decides unless specified as CIP 2. Don't allow precast when collars are present 3. Have specified precast when it was necessary to quickly complete a replacement structure	1. Headwalls can be precast 2. If end section is to be precast, it's required that everything be precast as an integral unit 3. Segmental construction is allowed but considered a modified design and must be approved by MoDOT	Good designs use AASHTO M 259 and M273 - if there are sections beyond the charts - Use BOXCAR	Bad designs don't meet AASHTO for min. slab thickness, joint details, reinforcement splice details at corners, etc. Also, if understrength or needs shear reinforcement	Construction office will look at AASHTO tables to see if the unit falls within the fill and size limits - if not it will be considered a 'modified design' and be sent to structures office for review	Yes, we worry and yes there is always the possibility of a ground failure but the probability is low and even less with the preliminary geotech report. If sinkholes is a concern, you may require a more extensive geotech work-up and then ground remediation, or put a bridge in.	1. Precast is a good option 2. Allows contractors flexibility in building culverts 3. Precast provides a 'jointless' unit, while CIP requires construction joints at the base and top of the walls	x Sent survey and received a response. Sent additional questions - received a response	Found specifications on website
Nevada	25+ years - not sure exactly how long the oldest unit has been in place	estimate about 15% are precast	Concrete durability is notably better - higher compressive strengths than CIP because of plant production	1. Most noted problems are associated with the joints - leakage, seepage, and resulting concrete deterioration - Cause of these problems is damage to keys during shipping and installation, inadequate joining of the units or placement of joint material 2. Settlement is also a problem	Square/Rectangular & Multiple cells through the use of multiple single cells placed and grouted together	1. Precast is usually specified to minimize duration of lane closures 2. Precast has also been used in remote locations, far away from a batch plant 3. Contractor usually has the option of precast or CIP	All would be CIP - connection to precast units by either drilling, doweling, or embedment in precast units	Junction Boxes or connections to laterals are best constructed CIP with precast continuing on either side		Working with construction personal and contractors to ensure the boxes are properly constructed and installed in accordance with specifications	Experience with precast has been good - no reservations about continued use	x Sent survey and received a response. Sent additional questions - waiting for a response	Specification requirements	
New Hampshire													x No contact information given for NHDOT	Specification requirements & 7 cut sheets for regional precasters
New Jersey													x Did not give an email address, could not contact	Design Manual Guidelines, Std. Specs & Dwgs
New Mexico	Only one known precast box culvert in the state - cannot be of any help												x Did not send standard survey, but sent a few questions - received a response	None

APPENDIX D STATE SURVEY MATRIX

States	Years of use?	Frequency of use?	Advantages?	Problems/Disadvantages?	Types used?	When do you decide to use precast as opposed to CIP? Or does the Contractor decide?	How do you deal with Headwalls / Endwalls / Wingwalls?	What makes for a good design?	What makes for a bad design?	Special Requirements?	Failures?	Personal Opinion?	State Status x - finished	Documents
New York	Oldest go back to about 1980 - survey done in 1994 and found no problems	Believed to have very low usage of CIP boxes	1. Units can be manufactured in a controlled environment 2. Units can be fabricated ahead of time and installed on a project much quicker than CIP 3. Cost of maintenance and protection of traffic on a job can be high, so the reduction in time with the use of precast is a real plus	1. Not aware of any problems with older installations 2. Leaky joints bit culvert sections - compressible foam gasket - intended to keep backfill out of joint but doesn't provide a water tight joint 3. There was some under mining of wingwalls that were placed on a crushed stone base - practiced is no longer allowed	1. Multi cell boxes are rarely used - occasionally side by side square culverts are used 2. Use larger 3-sided culvert systems such as ConSpan, HySpan, and Bebo	Decisions made by regional design engineers	1. Headwalls are usually CIP - allows for more flexibility 2. Use of precast wingwalls has been increasing over the last few years - about half of the wingwalls are now precast	They have a structures design committee that is currently preparing some standard design sheets showing all our typical precast box culvert details and wingwall details - used by regional designers as a guide on how to present culvert details in contract plans		Due to leaky joints - specify a waterproof membrane to cover the joints		Pro precast - believe precasters in NY manufacture a good product - units are produced in a more or less controlled environment and can be easily monitored by the inspection staff	x Sent survey and received a response. Sent additional questions - received a response	Fabrication & Construction Specification & Written design guidelines
Ohio	Using precast box culverts since 1979	Very little CIP being used - only used if load requirements are enough to require slab thicknesses > 16" (high fills for longer span structures)	1. Like b/c reduces construction time and once properly water-proofed, the structure is practically maintenance free 2. Ease of installation - 6" of compacted structural backfill, set boxes, backfill, pave, & finished 3. Design time - pretty much cut-and-paste work	Cannot think of any problems - Used to be rare cases of backfill material &/or water getting in through joints - easily solved by adding a water-proofing membrane over the exterior joints in the spec.	Three-sided flat topped precast concrete structures & precast arch top concrete structures	Precast is almost always given preference in designs b/c of the ease of design and construction. Occasionally, plans are set up to allow the contractor to decide, but precast is pretty much always used.	Wingwalls are usually CIP, but they may be either CIP or precast. If the Contractor decides to use precast, design must be approved by Structures Office. Currently, there are only 2 approved producers for precast wingwalls.	Designed using ASTM C1433, but limited to 12' - designed using BOXCAR or BRASS if over 12' - Controlling criteria - structure span and height of cover over top of box culvert & Output specifies rod rebar sizes and thickness of top slab to resist shear forces	Common error in the plans is the detail of the inlet end which may show a square "cut-off" end rather than the bevelled, bell end that should be shown - this detail impacts the hydraulic performance of the culvert	Waterproofing - accomplished thru use of Bituminous Pipe Joint Filler - filling the top ext. & bottom and side int. joint gaps with mortar. Ext. side joints are covered by a joint wrap and the top is covered by a Membrane Waterproofing Material	Not aware of any problems with precast discontinuity - Ohio has a precast supplier certification program that helps ensure that all precast producers are putting out consistent, good quality precast items	x Sent a survey and received a response. Sent additional question - received a response	Location and design manual & construction specifications	
South Dakota	Since the early 80's	About half are precast	1. Can save construction time 2. Precast options may fit some contractor's grading operations better than CIP and result in lower overall project bids	1. Box sections are sensitive to the amount of care the contractor takes in the installation process 2. Problems getting the joints to fit tight (contractor usually ends up grouting/patching areas where joints are excessive) 3. Concrete spalling has occurred where sections were impacted by other sections or equipment 4. Precast boxes usually cost more than CIP 5. Poor dimensional control in the field	Square and Rectangular	When there is an option in the plans, Contractors select precast the majority of the time				Recommend that inlet and outlet cutoff walls be specified on all drainage crossing type precast boxes - some in the past did not and experienced piping under and around the box sections and resulted in severe erosion under the entire length and around the ends along with major settlement of the sections	Not aware of any problems with material loss (sinkhole development) through the joints of our tied precast sections. Although there is always some degree of concern due to the shear number of joint, it appears that out joint treatment has been working. Not aware of failures in any other states.	x Precast culverts appear to be performing well. Precast culverts have a number more joints than the CIP culverts - when there has been trouble in the past with CIP, it has occurred at the joints, so one has to wonder how the precast will hold up in comparison to the CIP	Sent survey and received a response. Sent additional questions - received a response	Standard Specifications (found on website) & detail of a typical joint tie
Tennessee	About 25 years	Small - probably less than 1%	1. Speed of installation 2. Quality of concrete	No big problems	Only square or rectangular boxes are used	In the past, contractors proposed precast boxes as an alternate. Now, they are incorporated into their standard drawings - contractor stills decides, but contractors have been reluctant to use precast for some reason? - smaller contractors can build the culverts with their own crew and pocket more money than if they purchased the precast units & may not be familiar with the precast standards	Headwalls and Endwalls are CIP	Designs based on ASTM standards - a good design meets standards and is economical		Don't know of any major problems due to the discontinuity of precast culverts. Because some differential settlement is a possibility, the use of precast boxes with the top as a riding surface could be a problem. If there is fill, we don't think that there is a problem. Feel that the joint issue is under control	Precast is a good option, especially when speed of installation is an issue	x Sent survey and received a response. Sent additional questions - received a response	Design Criteria	

APPENDIX D STATE SURVEY MATRIX

States	Years of use?	Frequency of use?	Advantages?	Problems/Disadvantages?	Types used?	When do you decide to use precast as opposed to CIP? Or does the Contractor decide?	How do you deal with Headwalls / Endwalls / Wingwalls?	What makes for a good design?	What makes for a bad design?	Special Requirements?	Failures?	Personal Opinion?	State Status x - finished	Documents
Texas	Using precast box culverts since the mid 1970's - a precast standard was created in the early 1980s	Nearly half of the culverts are precast	Rise in the number due to demands for rapid construction	Occasional settlement problems which are usually related to poor compaction of the subgrade prior to placement of the boxes	Mostly use single cell and multi-cell (single units placed side-by-side). Also available are two U-shaped sections placed on top of each other to form a box, a single U-shaped section with a flat slab, and ConSpan designs (fairly limited use)	Usually the Contractor's decision, but sometimes precast is specified when speed of construction is important		Adopted the ASTM Specifications C789 and C850 - have had very few problems with the manufacture, installation, and long term performance of precast box culverts. In 2003, will be adopting the ASTM C1433 spec.				The current goal of "get in, get out, stay out" makes precast box culverts an excellent solution. The speed of construction and long term performance all fulfill these goals	x Sent survey and received a response.	Design Details & Precast Culvert Stds.
Virginia	First use was about 1977 or 1978	Overall about 90-95% of culverts are precast	Fabricators have become accustomed to requirements and now there are very few problems from a design standpoint and very seldom hear of an installation problem	1. Problems with joints that were not sealed properly and thus began to leak 2. Initially, there were cases where the fabrication was unacceptable and had to be rejected 3. Initial experience with endwalls and wingwalls was similar 4. Problems that they have experienced are usually due to poor fit-up as opposed to joint material	Multiple Barrel unit, but most installations that require more than one line are built with multiple lines of the single barrel culvert	1. Allow substitution of precast for practically all CIP installations - contractors generally opt to use precast 100% of the time when available 2. Specified precast on the plans when there is a need for rapid construction or minimizing the amount of road closure time.	Allow either precast or CIP - some fabricators prefer one way or the other - a rough estimate would be that 60-70% use precast headwalls and wings	Good designs adequately designed structurally (reasonable safety factor), an esthetic method of finishing the ends so that the structure looks good, and installed with minimal joint openings which are adequately sealed to prevent infiltration	Bad designs are ones where the fabrication and design are borderline - absolute minimum steel area used and no care is taken with regard to the esthetics of the final structure	Discontinuity is always a potential problem most likely to occur with bad fit-up. Recommend that the gap between units after placement not exceed 1/2" to 3/4" max. Fit-up, coupled with sufficient end anchorage (toe or scour wall is either CIP to "anchor" the line or sufficient mass is provided in the precast end section to resist sliding) prevents the precast units from separating due to internal pressures	Have been used extensively and they have served us well in almost every occasion. Design and fabrication need to be closely monitored in order to ensure a viable long-term product	x Sent survey and received a response. Sent additional questions - received a response	None	
Washington	Using 4-sided for about 10 years & recently using 3-sided with no bottom slab	Specify precast about 90% of the time	Good economy and rapid installation	Does not recall hearing about any maintenance problems with the 4-sided culverts. Reviewed recent inspection reports for some of the 3-sided and they are performing well. Some appearance issues due to poor fit-up - could become a maintenance issue in the future.	4-sided and 3-sided without a bottom slab	Generally, specify only precast for new installations. CIP is specified for extensions to existing CIP culverts or for additional cells. Decision is generally not made by the Contractor	Usually the wingwalls and headwalls are precast - attached after the culvert is installed	Begins with following the AASHTO code and specifying an appropriate design load - HS25 for 3-sided and HS20 for 4-sided located on secondary roads. Use design tables from ASTM C1433. Crack control and concrete cover requirements are important		If a structure will not have much soil cover, require epoxy coated bars or increased concrete cover One manufacturer provides a system of three separate pieces (top and 2 sides) - structure is unstable until the backfill has been placed - require moment connections for these structures	Do not know of any instances of failure. A washout of the three piece system could cause instability during the service life of the structure	3-sided structures are being used more frequently b/c they can have longer spans and are less restrictive to streams Constructability - important to provide even bedding for the foundation to ensure proper fit-up - one instance this caused poor fit-up and appearance and likely future maintenance problems	x Sent survey and received a response - sent additional questions - received a response	None

APPENDIX E STATE SPECIFICATION MATRIX

States	Standard Specifications / Details	Limitations	Wall thicknesses	Fill heights	Concrete Cover Requirements for less than 2' of fill	Concrete Cover Requirements for greater than 2' of fill	Bedding/Foundation Requirements	Joints materials	Joint Ties	Joint gap between sections	Additional waterproofing	Multi-cell installations
Florida	Specifications No standard details				meet AASHTO M 273 requirements: 2" for the top exterior slab cover and 1" for all remaining covers	meet AASHTO M 259 requirements: 1" for the top exterior slab cover and 1" for all remaining covers	Minimum of 6" depth of course concrete sand or other suitable granular material Minimum of 12" outside the exterior walls of the culvert	Butyl rubber preformed plastic gasket material & completely wrap outside of each joint with either a woven or non-woven filter fabric - minimum width of 2 ft and secure against culvert with metal strapping	When specified in plans, secure the joint by a suitable device capable of holding the sections to line and grade as well as fully home. Remove these devices after placing and compacting backfill to secure sections			
Illinois	Construction Specifications & Precast portion of the IDOT Culvert Manual (including details)	Maximum span and rise of 12" Minimum cover of 6", measured at the edge of the shoulder			meet AASHTO M 273 requirements: 2" for the top exterior slab cover and 1" for all remaining covers	meet AASHTO M 259 requirements: 1" for the top exterior slab cover and 1" for all remaining covers	Minimum of 6" layer of porous granular material. Minimum of 2" beyond each side of the box	Joints between each section shall be sealed and all voids filled with a mastic joint sealer. Joints shall be externally sealed on all 4 sides using 13" wide external sealing bands or 24" nonwoven geotechnical fabric - centered over joint and secured during backfill operation	One District in Illinois that insists on casting small holes in the mid-height of the walls. They then bolt an I-hook through the holes and use a threaded bar from I-hook to I-hook of adjacent sections to come-a-long the sections together - insist on leaving the threaded bars in place. We have had good success without this but measures like this can be done.			Nominal space of 3" between adjacent sections
Kansas	Standard Specifications & details			< 2 ft - requires a distribution slab Minimum of 1 ft to use precast distribution slab Epoxy coated rebar shall be used in the top slab when the fill at shoulder line is 6" or less	Clearances to rebar shall be a minimum of 2 1/2 inches in the top of the slab and 1 1/3 inches in the remaining faces	Clearances to rebar shall be a minimum of 1 1/3 inches from all faces	Crushed stone - gradation shall be adequate to provide a uniform foundation - minimum thickness of 6" Concrete Seal Course - commercial grade concrete - minimum thickness of 3"	Compound type joint filler or rubber gasket and an external sealing band such as geotextile fabric (conform to type A)				Must be significant economic justification Joint gap of 1" b/t sections To maintain proper joint gap, partially backfill boxes prior to grouting or provide mechanical connection b/t boxes
Minnesota	Standard details and Specifications		Tables for minimum wall thicknesses for specific span and rise dimensions	Tables for maximum fill heights for specific span and rise dimensions - fill heights of less than 2' require a distribution slab. A precast slab may be used for fill heights over 1' - provide 3" granular material between slab and barrel. A CIP slab must be 6" thick with required rebar	1 1/2" minimum and 2" maximum concrete cover on all reinforcement, including shear reinforcement, except for tongue and groove detail	2 1/2" minimum and 2" maximum concrete cover to reinforcement	Minimum of 6" of granular bedding - compaction adjacent to the bottom corner radii shall be accomplished with a mechanical hand compactor	Joint on the bottom of the culvert shall be sealed with a preformed mastic. A strip of geotextile material extending 12" or more on each section shall be placed over the joints on the top and sides in a manner that will prevent displacement during backfill operations. When required by Contract, joints shall be effectively sealed to provide a flexible watertight joint using an approved joint sealer material (preformed rubber, preformed plastic, or bituminous mastic)	Individual sections shall be tied together with concrete pipe ties - culvert ties are to be 1" diameter rods			If the distance between double barrels is less than 2' use either pea rock or lean mix backfill between the culverts - also provide approved grout seepage core, minimum 12" thick, between the culverts two ends - minimum distance required is 6"

APPENDIX E STATE SPECIFICATION MATRIX

States	Standard Specifications / Details	Limitations	Wall thicknesses	Fill heights	Concrete Cover Requirements for less than 2" of fill	Concrete Cover Requirements for greater than 2' of fill	Bedding/Foundation Requirements	Joints materials	Joint Ties	Joint gap between sections	Additional waterproofing	Multi-cell installations
Mississippi	Standard details		Tables for minimum wall thicknesses for specific span and rise dimensions	Tables for maximum fill heights for specific span and rise dimensions	meet AASHTO M 273 requirements: 2" for the top exterior slab cover and 1" for all remaining covers	meet AASHTO M 259 requirements: 1" for the top exterior slab cover and 1" for all remaining covers						
Missouri	Not a whole lot on precast - some standard specifications	If you start allowing too much clearance, you also risk larger crack widths and greater reinforcement exposure to the earth fill or road salts whichever is the case			meet AASHTO M 273 requirements: 2" for the top exterior slab cover and 1" for all remaining covers	meet AASHTO M 259 requirements: 1" for the top exterior slab cover and 1" for all remaining covers	Minimum of 6" layer of granular material placed directly below the elevation of the bottom of the box and end sections. Minimum of 18" beyond each side of the box	All joints between individual box sections shall be sealed with an approved plastic joint compound or a tubular joint seal - joints shall be forced together with excess compound extruding both inside and outside the joint				1 1/2 inch minimum space shall be left between the adjacent precast sections and following installation of the end sections, 1 1/2 inch space between the parallel sections shall be entirely filled with mortar for grout
Nevada	Specifications No standard details - prepared by precaster				meet AASHTO M 273 requirements: 2" for the top exterior slab cover and 1" for all remaining covers	meet AASHTO M 259 requirements: 1" for the top exterior slab cover and 1" for all remaining covers		Seal joints with flexible, watertight, preformed joint mastic		Maximum tolerable gap in the joints will be 0.75 inches, checked immediately after making each joint		Solidly fill the 3 in space between the box lines with grout
New Jersey	Specifications & standard details	Precast box culverts should not be used where the top slab is to be used as a riding surface	Wall thickness shall be a minimum of 8" and top & bottom slab thickness shall be a minimum of 10"	When less than 2 ft, the top mat of rebar in the roof slab shall be corrosion protected	1 1/2 in all around, except for 2 in for the exterior side of the top slab	1 1/2 in all around, except for 2 in for the exterior side of the top slab	Coarse aggregate layer (compacted) provided underneath culvert - minimum depth of 2 ft and must extend 12 inches on each side of the culvert	Flexible, watertight neoprene gasket provided at joints between the units - gasket shall be continuous around the circumference of the joint and shall contain only one splice - waterproofing between last precast sections and CIP sections In addition, a 2 ft wide strip of filter fabric placed over the top and side transverse joints	Units shall be tied together with a minimum of 4 longitudinal rods or strands to ensure an adequate seal and to provide continuity and concrete shear transfer between precast units		Units shall be given one coat of an epoxy waterproofing seal coat on the exterior of the roof slab - units shall be dry prior to application	Placed a maximum of 6 inches apart - filled with non-shrink grout or crushed stone with a 2'-8" wide strip of filter fabric placed over longitudinal joint
New York	Fabrication & Construction Specifications	Limited to certain sizes and skews	Exterior Wall - For spans: < 8' : min 6" <14' : min 8" < 20' : min 10" > 20' : min 12" Interior Wall - controlled by the design, but in no instance shall be less than 6"	When the fill is less than 2 ft, all reinforcing in the top mat of the roof slab shall be epoxy coated or the concrete shall contain corrosion inhibitor	meet AASHTO M 273 requirements: 2" for the top exterior slab cover and 1" for all remaining covers - ends of the longitudinal rebar shall have 1/2 inch min. concrete cover at the mating surface of the joint	meet AASHTO M 259 requirements: 1" for the top exterior slab cover and 1" for all remaining covers		Joints shall be sealed with a continuous gasket installed at the precast plant	Joints shall be drawn together with a mechanical connector - joint with a clear span greater than 4' shall have a minimum of 4 connectors required per joint multiplied by the number of joints (unless approved by the Engineer) - if the contract requires the connectors to be left in place, they must be located so that they do not cause an obstruction in the culvert	Gap between adjacent culvert sections shall be a maximum of 3/4 inches		Gap between the walls of adjacent cells to be 2-4". Gap should be filled with any approved concrete item

APPENDIX E STATE SPECIFICATION MATRIX

States	Standard Specifications / Details	Limitations	Wall thicknesses	Fill heights	Concrete Cover Requirements for less than 2' of fill	Concrete Cover Requirements for greater than 2' of fill	Bedding/Foundation Requirements	Joints materials	Joint Ties	Joint gap between sections	Additional waterproofing	Multi-cell installations
Ohio	Location & design manual & construction specifications - faxed details Currently working to develop a set of Std. Construction Dwgs. for wingwalls and headwalls to be used with typical sizes box culverts			Tables for maximum fill heights for specific span and rise dimensions	meet AASHTO M 273 requirements: 2" for the top exterior slab cover and 1" for all remaining covers - for all structures up to 12 feet in span - above 12 feet, provide the design and usually use 2" concrete cover on all surfaces for the rebar	meet AASHTO M 259 requirements: 1" for the top exterior slab cover and 1" for all remaining covers - above 12 feet, provide the design and usually use 2" concrete cover on all surfaces for the rebar	Structural backfill extending at least 6" below the bottom of the box for the full width of the width of the trench - minimum trench width of the span plus 2 ft on each side	Bituminous joint filler, preformed butyl rubber joint filler or a resilient and flexible gasket - for any exterior joint not covered by membrane waterproofing, cover with a 9" wide strip of joint wrap - use a continuous length of wrap sufficient to extend from the bottom of the vertical face on one side to the bottom vertical face on the other side			If shown on the plans, externally apply membrane waterproofing to the top surface and extend it vertically down on both sides of the structure Apply membrane waterproofing to all surfaces that will be in contact with the backfill	
Oregon	Standard details		Tables for minimum wall thicknesses for specific span and rise dimensions	Tables for maximum fill heights for specific span and rise dimensions - minimum fill is 2"	2" for the top exterior slab cover and 1 1/2" for all remaining covers unless shown otherwise	1 1/2" for all covers unless shown otherwise						
Pennsylvania	Design Specifications for ConSpan Bridges and single cell box culverts	The use of precast end components is not precluded, but will be reviewed on an individual basis by District Bridge Engineer	Ranges from 8" to 12" depending on culvert size	Less than 2' of fill requires a 5" minimum reinforced concrete deck	For welded wire fabric (WWF), provide 2" cover for top wires of top and bottom slab and 1 1/2" on all remaining covers. For conventional bars, provide 2 1/2" for top bars of top and bottom slab and 1 1/2" for all remaining covers	For welded wire fabric (WWF), provide 2" cover for top wires of bottom slab and 1 1/2" on all remaining covers. For conventional bars, provide 2" for top bars of top and bottom slab and 1 1/2" for all remaining covers		Provide 2' width and approved waterproofing membrane or adhesive-backed preformed membrane along side joints and joints in top slab of box for less than 2' of fill.				
South Dakota	Specifications & No standard details - Emailed about details	Minimum length of precast section is 4 ft and dry casting is not allowed			meet AASHTO M 273 requirements: 2" for the top exterior slab cover and 1" for all remaining covers	meet AASHTO M 259 requirements: 1" for the top exterior slab cover and 1" for all remaining covers	Bedding material shall be sand or selected sandy soil	Floor joints between sections shall be sealed with a preformed mastic to a point above the flow line. A strip of drainage fabric shall be placed along the top and walls - provide a minimum of 2 1/2 feet of fabric centered on the joint - Transverse joints in the fabric shall be overlapped at least 2 feet - sufficient adhesive shall be required along the edge of fabric to hold in place while backfilling	Shall be provided on all sections - ties are installed to help keep the individual sections held together during installation. Have seen un-tied concrete pipe and cattle pass sections separate over time (especially near the ends). The ties vary depending on the fabricator of the precast sections.			
Tennessee	Specifications and design details		Tables for minimum wall thicknesses for specific span and rise dimensions	Tables for maximum fill heights for specific span and rise dimensions	meet AASHTO M 273 requirements: 2" for the top exterior slab cover and 1" for all remaining covers	meet AASHTO M 259 requirements: 1" for the top exterior slab cover and 1" for all remaining covers	Minimum of 6" of granular foundation fill	Butyl rubber base or approved bituminous plastic or cement mortar	When first started allowing precast, required them to be post-tensioned together, but, subsequently decided that this was not needed			Fill gap between sections with either flowable fill grout or sand with at least the top two feet filled with flowable fill grout

APPENDIX E STATE SPECIFICATION MATRIX

States	Standard Specifications / Details	Limitations	Wall thicknesses	Fill heights	Concrete Cover Requirements for less than 2" of fill	Concrete Cover Requirements for greater than 2" of fill	Bedding/Foundation Requirements	Joints materials	Joint Ties	Joint gap between sections	Additional waterproofing	Multi-cell installations
Texas	Specification and details Standard on website is the result of an evolution in precast culvert design over the past 20+ years		Tables for minimum wall thicknesses for specific span and rise dimensions	Tables for maximum fill heights for specific span and rise dimensions	meet AASHTO M 273 requirements: 2" for the top exterior slab cover and 1" for all remaining covers	meet AASHTO M 259 requirements: 1" for the top exterior slab cover and 1" for all remaining covers						