

**State of Florida
Department of Transportation**



INVITATION TO BID
Barricades

DOT-ITB-24-9062-DG

EFFECTIVE DATES

February 9, 2024 - February 10, 2025

VENDOR

Safety Zone Holdings, Inc. DBA Safety Zone Specialists - CR850

BID SHEET
(Page 1 of 2)

BID #: DOT-ITB-24-9062-DG

FOB: Statewide

BID TITLE: Barricades

Note: In an emergency situation, barricades must be received within 24 hours of notification. In this case, freight will be prepaid by the vendor and added to the invoice as a separate item.

Only barricade brands listed on the Department of Transportation's Approved Products List (APL) will be considered for this bid.

Barricades bid must be in accordance with the State of Florida Department of Transportation Standard plans, 2024-2025, Index No. 102 and bear the DOT approval number.

DOT No.	Description	Manufacturer/Model No.	Length	APL No.	Price
103058	Barricade Type 1	Safety Zone Specialist TAS1236	36"	102-000-004	\$ 39.25
813206	Barricade Type 2	Safety Zone Specialists TAS824	24"	102-001-000	\$31.45
103056	Barricade Type 3	TraFFix Devices 56006-FHIP1R	6'	102-066-005	\$215.95

Manufacturer/Model number and APL information will be used in the evaluation.

Safety Zone Holdings, Inc dba Safety Zone Specialists

NCHRP 350 TYPE I Barricade Spec Sheet TAS1236

WORK ZONE BARRICADE WITH WOOD BOARDS AND STEEL LEGS SPECIFICATIONS

- **Folded Dimensions:**
Thickness: 1.81 Inches
Length: 24 to 36 Inches
Height: 45 Inches
- **Plywood Board Thickness:**
1/2 Inch.
- **Weight of Type I Barricade with 14 Gauge Steel Legs:** 25lbs
- **Leg Material:** 14 Gauge Galvanized Steel Roll Form.
- **Hinge Holes Accept 1/2" Warning Light Mounting Bolts.**
- **Board Colors:** White
- **All Sheeting Complies with ASTM 4956.01 requirements.**

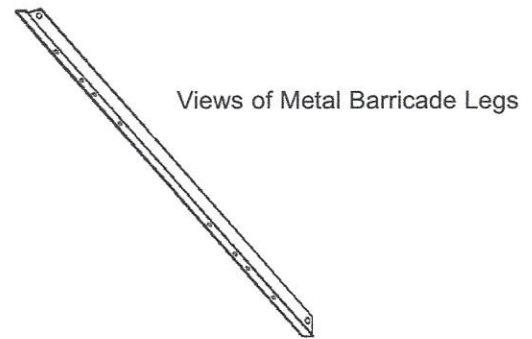
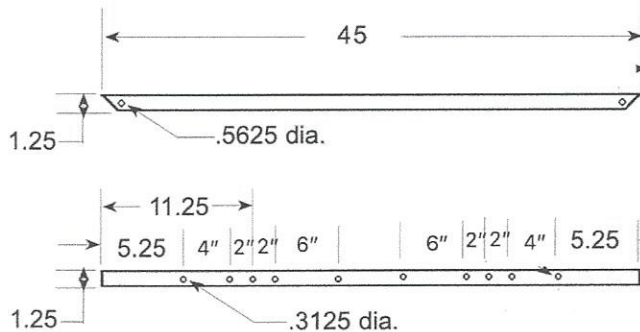
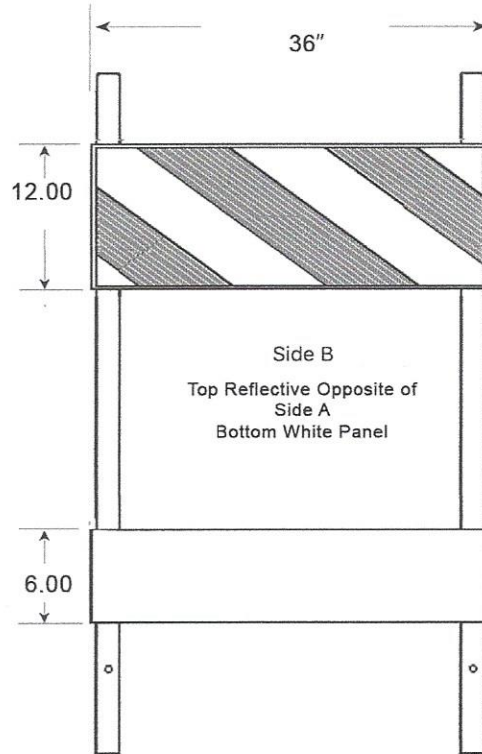
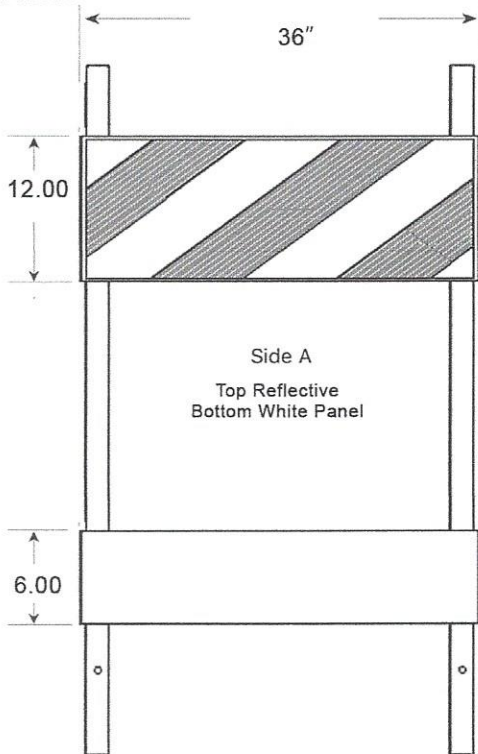

Views of Metal Barricade Legs



Distributed by
 **SAFETY ZONE**
SPECIALISTS
863-816-3402
www.safetyzonespecialists.com

Line 1

Plywood and Reflective Sheeting Dimensions

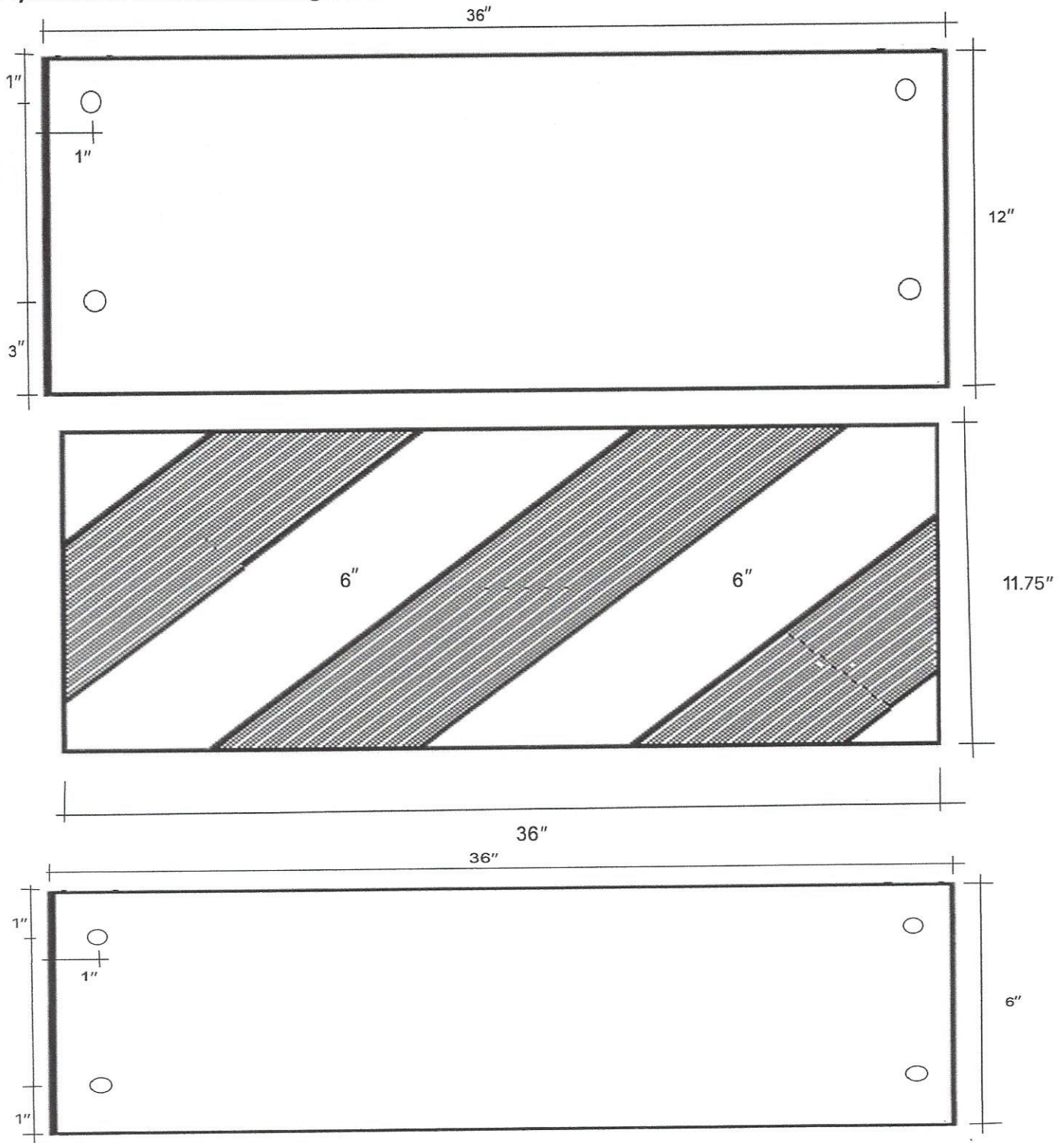

Bill of Materials

- (4) galvanized legs with holes punched as per drawing
- (2) 12" x 36" white plywood boards as per drawing
- (2) 6" x 36" white plywood boards as per drawing
- (2) bolts
- (2) nuts
- (16) rivets
- (2) piece orange and white reflective sheet with 4" lines left
- (2) piece orange and white reflective sheet with 4" lines right
- (1) Safety Zone Specialists stickers – on back of top panel



NCHRP 350 TYPE II Barricade Spec Sheet TAS824

WORK ZONE BARRICADE WITH WOOD BOARDS AND STEEL LEGS SPECIFICATIONS

- **Folded Dimensions:**
Thickness: 1.81 Inches
Length: 24 to 36 Inches
Height: 45 Inches
- **Plywood Board Thickness:**
1/2 Inch.
- **Weight of Type II Barricade with 14 Gauge Steel Legs:** 19 lbs
- **Leg Material:** 14 Gauge Galvanized Steel Roll Form.
- **Hinge Holes Accept 1/2" Warning Light Mounting Bolts.**
- **Board Colors:** White
- **All Sheeting Complies with ASTM 4956.01 requirements.**

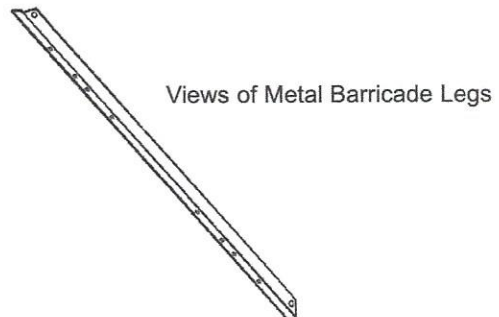
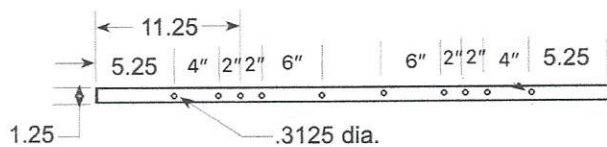
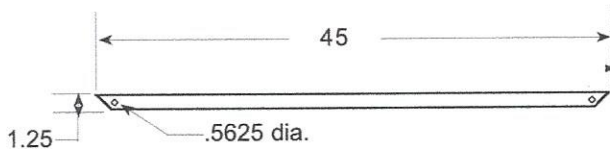
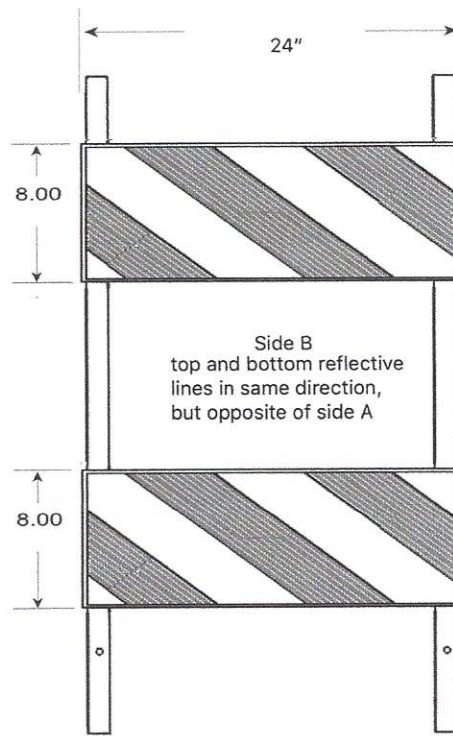
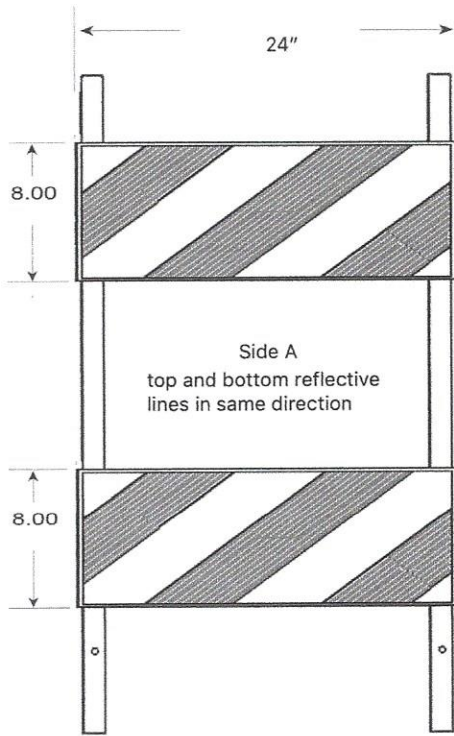

Plywood and Reflective Sheeting Dimensions

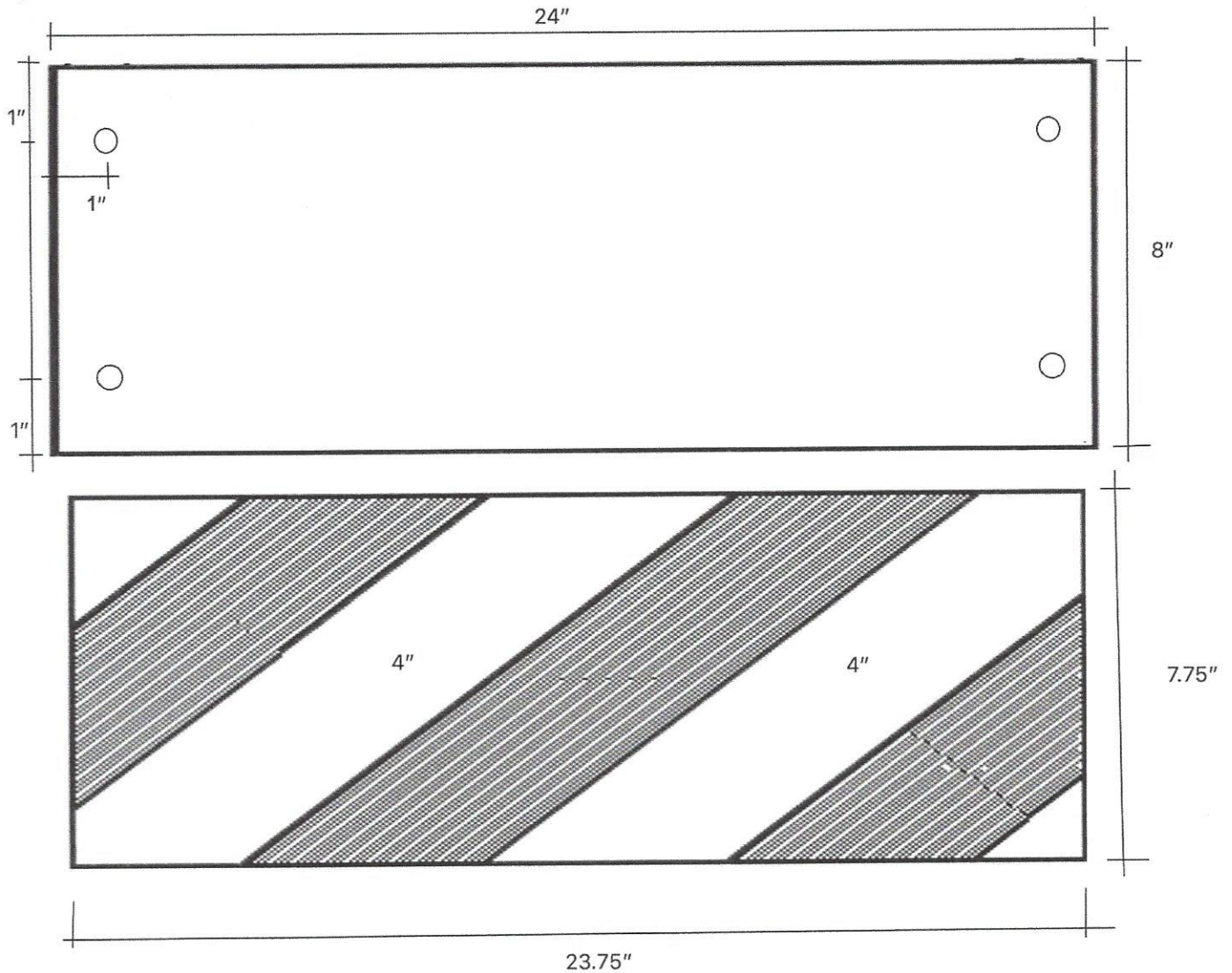

Bill of Materials

- (4) galvanized legs with holes punched as per drawing
- (4) 8" x 24" white plywood boards as per drawing
- (2) bolts
- (2) nuts
- (16) rivets
- (2) piece orange and white reflective sheet with 4" lines left
- (2) piece orange and white reflective sheet with 4" lines right
- (1) Safety Zone Specialists stickers – on back of top panel

Line 3



Economy Type III Barricade

56000 SERIES

Economy Type III Barricade with Phoenix Plastic Rails, provides low cost Type III solution with rolled steel uprights and feet. Choose the Phoenix Rails in lengths of 4', 6', 8', 10' and 12'.

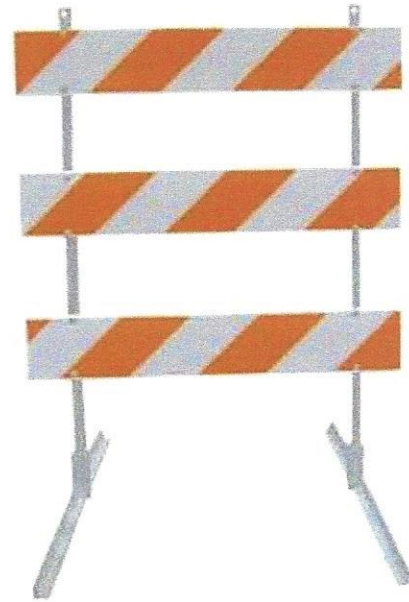

Complete Economy Type III Barricade can be assembled and disassembled in a matter of minutes by one person.

Safety Zone Holdings, Inc
dba SAFETY ZONE SPECIALISTS
PO BOX 90764
LAKELAND FL 33804-0764

9 4 9 . 3 6 1 . 5 6 6 3





TrafFix Devices Inc.

Type III Barricades

MASH
Manual for Assessing Safety Hardware

Tested, Passed and Eligible

TrafFix Devices offers Type III Barricades to meet all of your Traffic safety needs.

Type III Barricades are larger and offer better visibility compared to [Type I & II Barricades](#) and are available in 4', 6', 8', 10', and 12' lengths. These Barricades have a wide range of uses, but are typically used to designate road closures. With our large selection of reflective sheeting, lengths, and materials, the TrafFix Type III Barricades can be used all over the world for any situation.

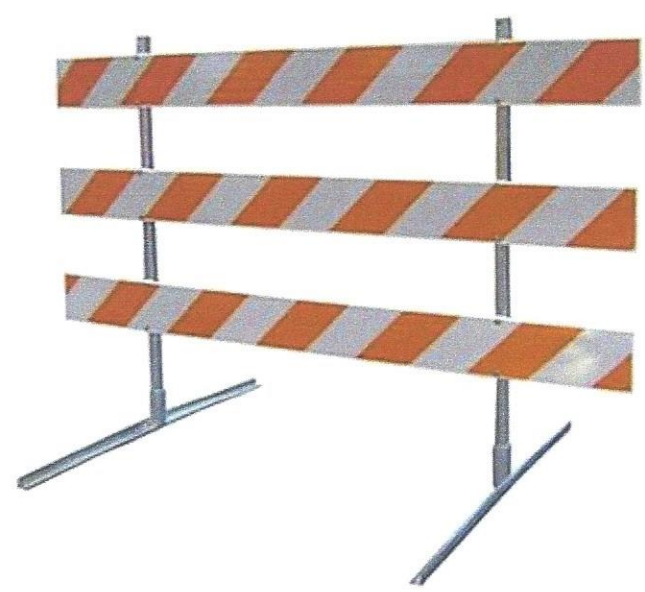

Economy Type III Barricade

Economy Type III 56000 Series

Economy Type III Barricade with Phoenix plastic rails, provides low cost Type III solution with rolled steel uprights and feet. Choose the Phoenix Rails in 4, 6, 8, 10 and 12 foot lengths. Economy Type III Barricade can be assembled and disassembled in a matter of minutes by a single person.

Safety Zone Holdings, Inc
dba SAFETY ZONE SPECIALISTS
PO BOX 90764
LAKELAND FL 33804-0764

BID SHEET

(Page 2 of 2)

BID #: DOT-ITB-24-9062-DG

FOB: Statewide

BID TITLE: Barricades

DELIVERY: Delivery will be made within 10 days after receipt of Purchase Order.

Is this product available with recycled content? Yes X No

If yes, please send information separate from this Invitation to Bid (See Recycled Material Special Condition for more information).

RENEWAL: see Introduction Section #7.

THE UNIT PRICE(S) WILL APPLY TO THE INITIAL TERM AND ANY RENEWAL PERIODS.

MFMP Transaction Fee:

All payment(s) to the vendor resulting from this competitive solicitation **WILL** be subject to the MFMP Transaction Fee in accordance with the attached Form PUR 1000 General Contract Condition #14. The Transaction Fees imposed shall be based upon the date of issuance of the payment.

NOTE: In submitting a response, the bidder acknowledges they have read and agree to the solicitation terms and conditions and their submission is made in conformance with those terms and conditions.

ACKNOWLEDGEMENT: I certify that I have read and agree to abide by all terms and conditions of this solicitation and that I am authorized to sign for the bidder. I certify that the response submitted is made in conformance with all requirements of the solicitation.

Bidder: Safety Zone Holdings, Inc dba Safety Zone Specialists FEID# 87-3165409

Address: PO Box 90764 City, State, Zip: Lakeland, FL 33804-0764

Phone: 863-816-3402 E-mail: ofcmgr@safetyzonespecialists.com

Authorized Signature:  Date: 12/29/23

Printed/Typed: Holly Mason Title: General Manager

ORDERING INSTRUCTIONS

Bid Number: DOT-ITB-24-9062-DG

Title: Barricades

NOTE: ALL ORDERS SHOULD BE DIRECTED TO:

FEDERAL EMPLOYER IDENTIFICATION NUMBER (FEID): 87-3165409

VENDOR: Safety Zone Holdings, Inc dba Safety Zone Specialists

ADDRESS: PO Box 90764

CITY, STATE, ZIP: Lakeland, FL 33804-0764

TELEPHONE: 863-816-3402

TOLL FREE NO.: N/A

DELIVERY: DELIVERY WILL BE MADE WITHIN 10 DAYS AFTER RECEIPT OF PURCHASE ORDER

PRODUCT INFORMATION: DIRECT QUESTIONS TO:

NAME & TITLE: Holly Mason, General Manager

ADDRESS: PO Box 90764

CITY, STATE, ZIP: Lakeland, FL 33804-0764

TELEPHONE: 863-816-3402

TOLL FREE NO.: N/A

E-MAIL ADDRESS: ofcmgr@safetyzonespecialists.com

WEB ADDRESS: www.SafetyZoneSpecialists.com

Will you accept the State of Florida Purchasing Card (VISA)? Yes No

INTRODUCTION SECTION

1) INVITATION

The purpose of this Invitation to Bid is to obtain competitive bids to establish a one (1) year contract for the purchase of barricades by the Department of Transportation, hereafter referred to as the "Department". The contract will become effective on the date the successful bidder(s) is approved for award and will expire one (1) year from that date. After the award, said bidder(s) will be referred to as the "Vendor(s)".

All commodities identified in this Invitation to Bid will be subject to the availability of identical commodities as provided by mandatory Department of Management Services' State Contract(s) at such time these commodities become available. In the event of duplication(s) of commodities, the Department of Management Services' mandatory State Contract shall prevail.

2) TIMELINE

Provided below is a list of critical dates and actions. These dates are subject to change. Notices of changes (Addenda) will be posted on the Florida Vendor Information Portal at <https://vendor.myfloridamarketplace.com/> (click on "Search Advertisements") under this bid number. It is the responsibility of all potential bidders to monitor this site for any changing information prior to submitting your bid.

ACTION / LOCATION	DATE	LOCAL TIME
DEADLINE FOR TECHNICAL QUESTIONS - (There is no deadline for administrative questions)	01-10-2024	5:00 PM
BIDS DUE (ON OR BEFORE) - Florida Department of Transportation Central Procurement Office Attn: Destyne Grayson Phone: (850) 414.4253 CO.Purch@dot.state.fl.us	01-25-2024	10:00 AM
PUBLIC OPENING - Florida Department of Transportation Central Procurement Office Attn: Destyne Grayson 605 Suwannee St. MS20 Tallahassee, FL. 32399-0450	01-25-2024	11:00 AM
POSTING OF INTENDED DECISION/AWARD -	01-29-2024	

3) BID OPENING AGENDA

The sealed bids will be opened by the Department's Procurement Office personnel at the date, time and location in the Timeline. All bid openings are open to the public and will be conducted according to the following agenda:

Opening remarks – Approximate time of 2 minutes by Department Procurement Office personnel.

Public input period – To allow a maximum of 15 minutes total for public input related to the bid solicitation.

Bids opened – At conclusion of public input or 15 minutes, whichever occurs first, bids received timely will be opened with bidder's name and prices to be read aloud.

Adjourn - After all bids received timely have been opened, the meeting will be adjourned.

4) SPECIAL ACCOMMODATIONS

Any person with a qualified disability requiring special accommodations at a pre-bid conference, public meeting, and/or opening shall contact the contact person at the phone number, e-mail address provided on the title page at least five (5) working days prior to the event. If you are hearing or speech impaired, please contact this office by using the Florida Relay Services which can be reached at 1 (800) 955-8771 (TDD).

5) CONTRACT USE

Use of the contract resulting from this bid will be optional for the Department. The Department reserves the right to solicit separate bids for any unusual or abnormal quantity requirements that may arise during the term of the contract.

6) ESTIMATED PURCHASES

It is anticipated that the Department will purchase approximately \$450,000.00 under any contract resulting from this bid. This estimated amount is given only as a guideline for preparing your bid and should not be construed as representing an actual amount to be purchased under this contract. The Vendor(s) shall supply, at bid prices, the actual amounts ordered regardless of whether the total of such amounts is more or less than anticipated. This bid and the resulting contract will be subject to annual appropriated funding.

7) RENEWAL

Upon mutual agreement, the Department and the Contract Vendor may renew the contract for a period that may not exceed 3 years or the term of the original contract, whichever is longer. The renewal must be in writing and signed by both parties and is subject to the same terms and conditions set forth in the initial contract and any written amendments signed by the parties. Any renewal shall specify the renewal price, as set forth in the solicitation response except that an agency may negotiate lower pricing. Renewal is contingent upon satisfactory performance evaluations and subject to the availability of funds.

SPECIAL CONDITIONS

1) MyFloridaMarketPlace

BIDDERS MUST BE ACTIVELY REGISTERED IN THE STATE OF FLORIDA'S MYFLORIDAMARKETPLACE SYSTEM BY THE TIME AND DATE OF THE BID OPENING OR THEY MAY BE CONSIDERED NON-RESPONSIVE (see Special Condition 21). All prospective bidders that are not registered should go to <https://vendor.myfloridamarketplace.com/> to complete on-line registration, or call 1-866-352-3776 for assisted registration.

All payment(s) to the vendor resulting from this competitive solicitation **WILL** be subject to the MFMP Transaction Fee in accordance with the referenced Form PUR 1000 General Contract Condition #14. The Transaction Fees imposed shall be based upon the date of issuance of the payment.

2) FLORIDA DEPARTMENT OF FINANCIAL SERVICES (DFS) W-9 REQUIREMENT

The Florida Department of Financial Services (DFS) requires all vendors that do business with the state to submit an electronic Substitute Form W-9. Vendors must submit their W-9 forms electronically at <https://flvendor.myfloridacfo.com> to receive payments from the state. Contact the DFS Customer Service Desk at (850) 413-5519 or FLW9@myfloridacfo.com with any questions.

3) QUESTIONS & ANSWERS

In accordance with section 287.057(25), Florida Statutes, respondents to this solicitation or persons acting

on their behalf may not contact, between the release of the solicitation and the end of the 72-hour period following the agency posting the notice of intended award, excluding Saturdays, Sundays, and state holidays, any employee or officer of the executive or legislative branch concerning any aspect of this solicitation, except in writing to the procurement officer or as provided in the solicitation documents. Violation of this provision may be grounds for rejecting a response.

Any technical questions arising from this Invitation to Bid must be forwarded, in writing, to the procurement agent identified below. Questions must be received no later than the time and date reflected on the Timeline. The Department's written response to written inquiries submitted timely by bidders will be posted on the Florida Vendor Information Portal at <https://vendor.myfloridamarketplace.com/> (click on "Search Advertisements"), under this bid number. It is the responsibility of all potential bidders to monitor this site for any changing information prior to submitting their bid.

WRITTEN TECHNICAL QUESTIONS should be submitted to:

FDOT Procurement Office

Attn: Destyne Grayson

Email: CO.Purch@dot.state.fl.us

Questions regarding administrative aspects of the bid process should be directed to the Procurement Agent in writing at the address above or by phone: (850) 414.4253.

4) ORAL INSTRUCTIONS / CHANGES TO THE INVITATION TO BID (ADDENDA)

No negotiations, decisions, or actions will be initiated or executed by a bidder as a result of any oral discussions with a State employee. Only those communications which are in writing from the Department will be considered as a duly authorized expression on behalf of the Department.

Notices of changes (Addenda) will be posted on the Florida Vendor Information Portal at <https://vendor.myfloridamarketplace.com/> (click on "Search Advertisements") under this bid number. It is the responsibility of all potential bidders to monitor this site for any changing information prior to submitting your bid. All Addenda will be acknowledged by signature and subsequent submission of Addenda with bid when so stated in the Addenda.

5) DIVERSITY ACHIEVEMENT

The Department, in accordance with *Title VI of the Civil Rights Act of 1964, 42 USC 2000d-2000d-4, Title 49, Code of Federal Regulations, U.S. Department of Transportation, Subtitle A, Office of the Secretary, Part 21*, Nondiscrimination in federally-assisted programs of the Department of Transportation issued pursuant to such Act, hereby notifies all bidders that the Department will affirmatively ensure that in any contract/agreement entered into pursuant to this advertisement, minority and disadvantaged business enterprises will be afforded the full opportunity to submit bids in response to this invitation and will not be discriminated on the basis of race, color, national origin, or sex in consideration for an award.

The Department encourages the recruitment and utilization of small, minority, women, and service-disabled veteran businesses. The Department, its vendors, suppliers, and consultants should take all necessary and reasonable steps to ensure that small, minority, women, and service-disabled veteran businesses have the opportunity to compete for and perform contract work for the Department in a nondiscriminatory environment.

6) PRICES/DELIVERY

Prices shall be firm, net, delivered prices, F.O.B. destination.

Delivery must be made within thirty (30) calendar days or less upon receipt of a purchase order by the contract vendor at their designated ordering location. If more time is needed, the bidder should state the

extra time required and the reasons why, in their bid response. Acceptance will be subject to the Department's approval.

7) EXPEDITED DELIVERY

In an emergency situation, barricades must be received within 24 hours of notification. In this case, freight will be prepaid by the vendor and added to the invoice as a separate item.

8) IN-STATE PREFERENCE FOR COMMODITY BIDS

In accordance with Section 287.084, Florida Statutes, when the lowest responsible and responsive bid is submitted by a vendor whose principal place of business is located outside the state of Florida, a 5% price preference shall be awarded to the lowest responsible and responsive vendor whose principal place of business is located in the state of Florida, as determined by the vendor's registration with the Florida Department of State (SunBiz), unless the state where the out-of-state vendor is located provides a price preference for businesses having a principal place of business in that state. In that case, the same price preference shall be awarded to the lowest responsible and responsive vendor whose principal place of business is located in the state of Florida responding to this Invitation to Bid (ITB).

All bidders **MUST** complete the attached "In-State Preference Form" and submit with their bid response. All vendors whose principal place of business is outside of Florida, as determined by the vendor's registration with the Florida Department of State (SunBiz), **must accompany any written bid, proposal, or reply documents** with a written opinion of an attorney at law licensed to practice law in that foreign state, as to the preferences, if any or none, granted by the law of that state to its own business entities whose principal places of business are in that foreign state in the letting of any or all public contracts. Failure to submit the "In-State Preference Form AND written opinion will result in the vendor being found non-responsive.

For the 5% preference, the Department will apply 5% to the bid price(s) of the lowest out of state vendor whose state does not grant a preference if that vendor has submitted the lowest responsible and responsive bid. The "In-State Preference" does not apply to transportation projects that use federal funds.

9) INTENDED AWARD

As the best interest of the State may require, the right is reserved to make award(s) by individual item, group of items, all or none, or a combination thereof: on a geographical district basis and / or on a statewide basis with one or more suppliers to reject any and all bids or waive any minor irregularity or technicality in bids received. When it is determined there is competition to the lowest responsible bidder, evaluation of other bids is not required. Bidders are cautioned to make no assumptions, unless their bid has been evaluated as being responsive. All awards made as a result of this bid shall conform to applicable Florida Statute. If the Department is confronted with identical pricing or scoring from multiple vendors, the Department shall determine the order of award using the following criteria, in the order of preference listed below (from highest priority to lowest priority):

1. Section 295.187(4), Florida Statutes; Veteran Business Enterprise
2. Section 287.087, Florida Statute; Drug Free Work Place
3. Section 287.057(11); Minority Business Enterprise

In the event that the application of the above referenced preferences does not resolve the identical replies, the Department shall determine the award by means of random drawing.

10) PRE-BID CONFERENCE:

A PRE-BID CONFERENCE WILL NOT BE HELD.

11) ALTERNATES

Only barricade brands listed on the department of Transportation's Approved Products List will be considered for this bid.

12) WARRANTY/SUBSTITUTIONS

A warranty is required on all items purchased against defective materials, workmanship, and failure to perform in accordance with required industry performance criteria, for a period of not less than ninety (90) days from the date of acceptance by the purchaser. Any deviation from this criteria must be documented in the bid response or the above statement shall prevail. Delivery of substitute commodities requires prior written approval from the ordering location.

13) REPLACEMENT/RESTOCKING

Replacement of all materials found defective within the warranty period shall be made without cost to the purchaser, including transportation if applicable. All fees associated with restocking cancelled orders shall be the responsibility of the vendor.

14) PRODUCT REQUIREMENTS/SPECIFICATIONS

Items furnished shall be standard products of the manufacturer or their suppliers, shall be new, unused, clean, and free from any defects or features affecting appearance, serviceability, or the safety of the user in normal intended use.

Any deviation from specifications indicated herein must be clearly pointed out; otherwise, it will be considered that items offered are in strict compliance with these specifications, and successful bidder will be held responsible therefore. Deviations must be explained in detail on separate attached sheet(s).

15) ACCEPTANCE

All items listed in the specifications, delivered to the Department not meeting specifications or found to be poorly manufactured will not be accepted, but returned to the vendor, at their expense, for replacement. Replacement of all items found defective shall be made without cost to the Department, including transportation, if applicable. As it may be impossible for each facility to inspect all items upon arrival, a reasonable opportunity must be given to these facilities for inspection of the items, and returning those that are defective.

16) REVIEW OF BIDDER'S FACILITIES & QUALIFICATIONS

After the bid due date and prior to contract execution, the Department reserves the right to perform or to have performed, an on-site review of the bidder's facilities and qualifications. This review will serve to verify data and representations submitted by the bidder and may be used to determine whether the bidder has adequate facilities, equipment, qualified and experienced staff, and overall management capabilities to provide the required items. The review may also serve to verify whether the bidder has financial capabilities adequate to meet the contract requirements.

Should the Department determine that the bid package has material misrepresentations or that the size or nature of the bidder's facilities, equipment, management capabilities, or the number of experienced personnel (including technical staff) are not adequate to ensure satisfactory contract performance, the Department has the right to reject the bid.

17) PROTEST OF INVITATION TO BID SPECIFICATIONS

Any person who is adversely affected by the contents of this Invitation to Bid must file the following with the Department of Transportation, Clerk of Agency Proceedings, Office of the General Counsel, 605 Suwannee Street, Mail Station 58, Tallahassee, Florida 32399-0450:

1. A written notice of protest within seventy-two (72) hours after the posting of the solicitation, (the notice of

protest may be Faxed to 850-414-5264), and

2. A formal written protest in compliance with Section 120.57(3), Florida Statutes, within ten (10) days of the date on which the written notice of protest is filed.

Failure to file a protest within the time prescribed in section 120.57(3), Florida Statutes, or failure to post the bond or other security required by law within the time allowed for filing a bond shall constitute a waiver of proceedings under Chapter 120, Florida Statutes.

18) UNAUTHORIZED ALIENS

The employment of unauthorized aliens by any contractor is considered a violation of Section 274A(e) of the Immigration and Nationality Act. If the contractor knowingly employs unauthorized aliens, such violation shall be cause for unilateral cancellation of the contract.

19) SCRUTINIZED COMPANIES LISTS

ALL Responses, regardless of dollar value, must include a completed [Vendor Certification Regarding Scrutinized Companies Lists](#) to certify the respondent is not on either of those lists. The Form should be submitted with the bid response.

A Vendor is ineligible to enter into a contract with the Department for goods or services of any amount if, at the time of entering into such contract, the Vendor is on the Scrutinized Companies that Boycott Israel List, created pursuant to Section 215.4725, Florida Statutes, or is engaged in a boycott of Israel.

Section 287.135, Florida Statutes, also prohibits companies from entering into a contract for goods or services of \$1 million or more that are on either the Scrutinized Companies with Activities in Sudan List or the Scrutinized Companies with Activities in the Iran Petroleum Energy Sector Lists which were created pursuant to s. 215.473, Florida Statutes.

If the Department determines the Vendor submitted a false certification under Section 287.135 of the Florida Statutes, the Department shall either terminate the Contract after it has given the Vendor notice and an opportunity to demonstrate the Department's determination of false certification was in error pursuant to Section 287.135 of the Florida Statutes, or maintain the Contract if the conditions of Section 287.135 of the Florida Statutes are met.

20) RESERVATIONS

The Department reserves the right to accept or reject any or all bids received and reserves the right to make an award without further discussion of the bids submitted. Therefore, the bidder should make sure that the bid package submitted is complete and accurate and submitted to ensure delivery on or before the bid opening time and date specified in this solicitation. It is understood that the bid will become a part of the Department's official file, without obligation to the Department.

21) ADDITIONAL TERMS & CONDITIONS

No conditions may be applied to any aspect of the ITB by the bidder. Any conditions placed on any aspect of the bid documents by the bidder may result in the bid being rejected as a conditional bid (see "RESPONSIVENESS OF BIDS"). **DO NOT WRITE IN CHANGES ON ANY ITB SHEET.** The only recognized changes to the ITB prior to bid opening will be a written Addenda issued by the Department.

22) RESPONSIVENESS OF BIDS

Bids will not be considered if not received by the Department **on or before** the date and time specified as the due date for submission. All bids must be typed or printed in ink. A responsive bid is an offer to provide the

items specified in this Invitation to Bid in accordance with all requirements of this Invitation to Bid. Bids found to be non-responsive will not be considered. Bids may be rejected if found to be irregular or not in conformance with the specifications and instructions herein contained. A bid may be found to be irregular or non-responsive by reasons that include, but are not limited to, failure to utilize or complete prescribed forms, modifying the bid specifications, submitting conditional bids or incomplete bids, submitting indefinite or ambiguous bids, or executing forms or the bid sheet with improper and/or undated signatures. Other conditions which may cause rejection of bids include, evidence of collusion among bidders, obvious lack of experience or expertise to provide the required items, and failure to perform or meet financial obligations on previous contracts. ALL determinations of responsiveness will be the responsibility of the FDOT Procurement Office.

23) REQUIRED DOCUMENTS

The bidder must use the attached Bid Sheet to submit its bid. The Bid Sheet must be signed and dated in ink by a representative who is authorized to contractually bind the bidder. All bid sheets and other documentation submitted in response to this solicitation must be executed and submitted in accordance with Special Condition 27.

24) "DRUG-FREE WORK PLACE" PREFERENCE

Whenever two or more bids which are equal with respect to price, quality, and service are received, the Department shall determine the order of award first in accordance with section 295.187(4), Florida Statutes, giving preference to "Veteran Business Enterprise" then to bid responses from vendors that certify the business has implemented a drug-free workplace program in accordance with Section 287.087, Florida Statutes. The "Drug-Free Workplace Program Certification" must be completed and submitted with the bid response to be eligible for this preference.

25) COPYRIGHTED MATERIAL

Copyrighted material will be accepted as part of a bid only if accompanied by a waiver that will allow the Department to make paper and electronic copies necessary for the use of Department staff and agents. It is noted that copyrighted material is not exempt from the Public Records Law, Chapter 119, Florida Statutes. Therefore, such material will be subject to viewing by the public, but copies of the material will not be provided to the public.

26) ATTACHMENT TO ITB SUBMITTAL - CONFIDENTIAL MATERIAL

The Bidder must include any materials it asserts to be exempted from public disclosure under Chapter 119, Florida Statutes, in a separate email document labeled "Attachment to Invitation to Bid, Number DOT-ITB-24-9062-DG - Confidential Material". The Bidder must identify the specific Statute that authorizes exemption from the Public Records Law. Any claim of confidentiality on materials the Bidder asserts to be exempt from public disclosure and placed elsewhere in the bid will be considered waived by the Bidder upon submission, effective after opening.

27) ELECTRONIC SUBMISSION OF BIDS:

Please follow the below instructions for the submittal of electronic bids, failure to do so, may result in your bid being found non-responsive. Non-responsive replies will not be evaluated.

- a) Subject line must show: DOT-ITB-24-9062-DG – Vendor's Name
- b) Email shall contain one file attachment marked as the following: DOT-ITB-24-9062-DG Bid Submittal
- c) Documents shall be submitted in portable document format (PDF) and have a size limit of 25MB.
- d) Documents shall not be submitted in a ZIP (.zip) file.
- e) The body of the email shall not contain any information.

- f) Bids shall be submitted to: CO.Purch@dot.state.fl.us

It is the bidder's responsibility to assure that the bid is delivered to the proper place **on or before** the Bid Due date and time (See Introduction Section 2 Timeline). Bids which for any reason are not so delivered, will not be considered.

28) MODIFICATIONS, RESUBMITTAL AND WITHDRAWAL

Bidders may modify submitted bids at any time prior to the bid due date. Requests for modification of a submitted bid shall be in writing and must be signed by an authorized signatory of the bidder. Upon receipt and acceptance of such a request, the entire bid will be returned to the bidder and not considered unless resubmitted by the due date and time. Bidders may also send a change in a separate email to be opened at the same time as the bid.

29) POSTING OF INTENDED DECISION/AWARD

29.1 - General:

The Department's decision will be posted on the Florida Vendor Information Portal at <https://vendor.myfloridamarketplace.com/>, on the date in the Timeline, and will remain posted for a period of seventy-two (72) hours. Any bidder who is adversely affected by the Department's recommended award or intended decision must file the following with the Department of Transportation, Clerk of Agency Proceedings, Office of the General Counsel, 605 Suwannee Street, Mail Station 58, Tallahassee, Florida 32399-0450:

1. A written notice of protest within seventy-two (72) hours after posting of the Intended Award, (the notice of protest may be Faxed to 850-414-5264), and
2. A formal written protest and protest bond in compliance with Section 120.57(3), Florida Statutes, within ten (10) days of the date on which the written notice of protest is filed. At the time of filing the formal written protest, a bond (a cashier's check or money order may be accepted) payable to the Department must also be submitted in an amount equal to one percent (1%) of the estimated contract amount based on the contract price submitted by the protestor.

Failure to file a protest within the time prescribed in Section 120.57(3), Florida Statutes, or failure to post the bond or other security required by law within the time allowed for filing a bond shall constitute a waiver of proceedings under Chapter 120, Florida Statutes.

29.2 - Inability to Post:

If the Department is unable to post as defined above, the Department will notify all bidders by electronic notification on the Florida Vendor Information Portal (see special condition 28.1, above) and/or telephone. The Department will provide notification of any future posting in a timely manner.

29.3 - Request to Withdraw Bid:

Requests for withdrawal will be considered if received by the Department, in writing, within seventy-two (72) hours after the bid opening time and date. Requests received in accordance with this provision will be granted by the Department upon proof of the impossibility to perform based upon obvious error on the part of the bidder. Bidders that do not withdraw as stated above will forfeit their bid bond, if applicable.

30) RECYCLED MATERIAL

The Department encourages the use of products and materials with recycled content and post-consumer

recovered materials. If the item(s) specified in the Technical Specification is available with recycled content, we request that you provide product information to help in our search for recycled products. However, this bid request is for the product as specified herein and does not require prices for recycled product. This information should be sent as part of your bid response or may be sent separately.

31) PRICE ADJUSTMENTS

Price(s) shall remain firm for the life of the contract. Price adjustments will not be allowed.

32) DELIVERY LOCATION(S)

The primary point of delivery for this contract will be FDOT Warehouses. However, shipments can be made to any other location throughout the State of Florida. To access the list of other locations the list is available at the following website: http://www.fdot.gov/maintenance/RA_map.shtm

33) CANCELLATION

All contract obligations shall prevail for at least one hundred and eighty (180) days after the effective date of the contract. For the protection of both parties, this contract may be cancelled in whole or in part after one hundred and eighty (180) days by either party giving thirty (30) days prior written notice to the other contract party. The contract may, also, be cancelled by the Department for nonperformance (default) in accordance with Rule 60A-1.006(3), F.A.C.

34) ORDERING INSTRUCTIONS

Manufacturers are encouraged to bid direct naming dealers who will accept orders and complete deliveries. Bidders must include complete ordering instructions, including FEDERAL EMPLOYER IDENTIFICATION NUMBER (FEID), for invoicing dealers, with the bid on a separate sheet.

35) ORDER QUANTITIES

No minimum order quantities will be accepted. The "DOT" reserves the right to order on an as needed basis.

36) OPEN PURCHASE ORDERS

The Department may, at its discretion, establish an open (estimated quantity) purchase order with the contract vendor(s) to facilitate the purchasing of materials. The purchase of materials may be placed by; (1) written purchase order, (2) telephone orders by authorized Department personnel, or (3) an itemized order in writing. The Department will supply the contract vendor(s) with a list of personnel authorized to order. Delivery of items on these open purchase orders shall not exceed the contract effective period.

37) INVOICING

Invoices must match units specified on the Purchase Order.

38) FORMS

The Bidder must complete all required items below and submit them as part of the Bid package. Any Bid in which these forms are not used or in which these forms are improperly executed may be considered non-responsive and the bid may be subject to rejection.

Bid Sheet

Drug-Free Workplace Program Certification (if applicable)

In-State Preference

Vendor Certification Regarding Scrutinized Companies Lists (Form 375-030-60)

Ordering Instructions

39) TERMS AND CONDITIONS

39.1 General Contract Conditions (PUR 1000)

The State of Florida's General Contract Conditions are outlined in form PUR 1000, which is a downloadable document incorporated into this Invitation to Bid (ITB) by reference. Any terms and conditions set forth in this ITB document will take precedence over the PUR 1000 form where applicable.

<http://www.dms.myflorida.com/content/download/2933/11777/1000.pdf>

The following paragraphs do not apply to this Invitation to Bid:

Paragraph 31, Dispute Resolution - PUR 1000

Paragraph 40, PRIDE – PUR 1000, when federal funds are utilized.

39.2 General Instructions to Respondents (PUR 1001)

The State of Florida's General Instructions to Respondents are outlined in form PUR 1001, which is a downloadable document incorporated into this Invitation to Bid (ITB) by reference. Any terms and conditions set forth in this ITB document take precedence over the PUR 1001 form where applicable.

<http://www.dms.myflorida.com/content/download/2934/11780/1001.pdf>

The following paragraphs do not apply to this Invitation to Bid:

Paragraph 3, Electronic Submission – PUR 1001

Paragraph 4, Terms and Conditions – PUR 1001

Paragraph 5, Questions – PUR 1001

39.3 MFMP Purchase Order Terms and Conditions

All MFMP Purchase Order contracts resulting from this solicitation will include the terms and conditions of this solicitation and the State of Florida's standardized Purchase Order Terms and Conditions, which can be found at the Department of Management Services website at the following link:

http://www.dms.myflorida.com/content/download/117735/646919/Purchase_Order_Terms_Sept_1,_2015_.pdf

Section 8(B), PRIDE, is not applicable when using federal funds.

40) ORDER OF PRECEDENCE

All responses are subject to the terms and conditions of this solicitation, which, in case of conflict, shall have the following order of precedence listed:

Special Conditions

Technical Specifications

Bid Sheet

MFMP Purchase Order Terms and Conditions – Section 8(B), PRIDE, is not applicable when using federal funds.

General Instructions to Respondents (PUR 1001)

General Contract Conditions (PUR 1000)

Introduction Section

41) LIQUIDATED DAMAGES

As timely delivery is of importance to the functioning of the agency, the Department reserves the right to cancel such items of the contract which are not delivered within the required time for such items. Failure by the Vendor(s) to deliver items as specified within the stated time shall subject the Vendor(s) to liquidated damages in the amount of one percent (1%) of the bid price of the items for each day beyond the stated time.

42) APPROVED PRODUCTS

Approved Products List (APL) is published by the Department of Transportation and maintained by the State Specifications Office as an assurance to contractors, consultants, designers and the department that certain products and materials have a basic approval generally subject to additional testing of individual lots, batches or shipments to construction projects or against maintenance purchases. The APL is available on the World Wide Web at

<http://www.fdot.gov/procurementmanagement/ProductEvaluation/Default.shtm>

To qualify as an acceptable product for this bid, the product shall be either listed in the published Department of Transportation Approved Products List or have been approved by the Department of Transportation by the day before the opening of this bid. Products provided shall be approved throughout the term of the contract.