



POLK COUNTY ROADS AND DRAINAGE DIVISION

CONTRACT PLANS

POLK COUNTY  
 COUNTY ROAD NO. 557  
 PROJECT NO. 18-73

SIGNING AND PAVEMENT MARKING PLANS

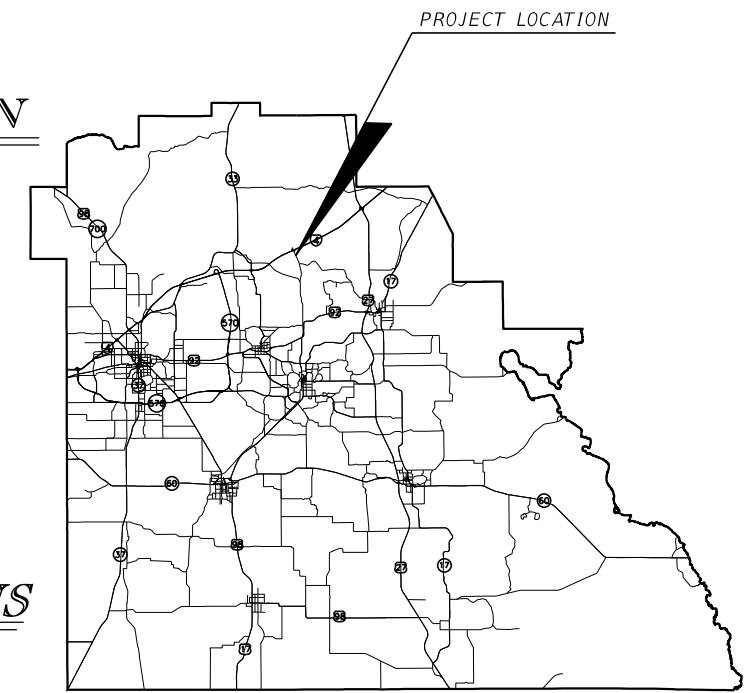

INDEX OF SIGNING AND PAVEMENT MARKING PLANS

SHEET NO.	SHEET DESCRIPTION
S-1	KEY SHEET
S-2 TO S-9	TABULATION OF QUANTITIES
S-10	GENERAL NOTES AND DETAILS
S-11 TO S-63	SPM PLAN SHEETS
S-64 TO S-65	INTERSECTION DETAILS
S-66 TO S-68	GUIDE SIGN WORKSHEETS
S-69 TO S-73	GUIDE SIGN CROSS SECTIONS

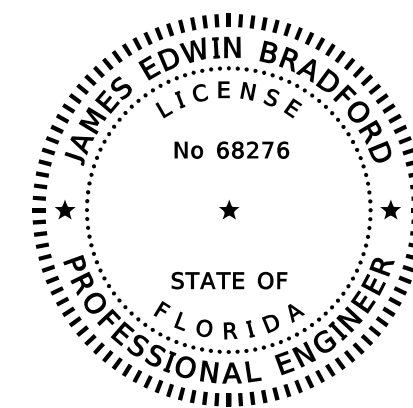

THIS DOCUMENT HAS BEEN DIGITALLY SIGNED AND SEALED BY:

PRINTED COPIES OF THIS DOCUMENT ARE NOT CONSIDERED SIGNED AND SEALED. THE SIGNATURE MUST BE VERIFIED ON THE ELECTRONIC DOCUMENTS.

90% SUBMITTAL  
 FEBRUARY 2023  
 PRELIMINARY NOT  
 FOR CONSTRUCTION

SIGNING AND PAVEMENT MARKING PLANS  
 ENGINEER OF RECORD:

JAMES E. BRADFORD, P.E.  
 P.E. LICENSE NUMBER 68276  
 DEWBERRY ENGINEERS INC.  
 800 N. MAGNOLIA AVENUE, SUITE 1000  
 ORLANDO, FL 32803  
 CERTIFICATE OF AUTHORIZATION 8794

POLK COUNTY PROJECT MANAGER:  
 AUSTIN POTTS, P.E.

SHEET NO.  
 S-1

THE OFFICIAL RECORD OF THIS SHEET IS THE ELECTRONIC FILE DIGITALLY SIGNED AND SEALED UNDER RULE 61G15-23.004, F.A.C.

TABULATION OF QUANTITIES

PAY ITEM NO.	DESCRIPTION	UNIT	SHEET NUMBERS														TOTAL THIS SHEET	
			S-11		S-12		S-13		S-14		S-15		S-16		S-17		PLAN	FINAL
			PLAN	FINAL	PLAN	FINAL	PLAN	FINAL	PLAN	FINAL	PLAN	FINAL	PLAN	FINAL	PLAN	FINAL		
630-2-11	CONDUIT, F&I, OPEN TRENCH	LF																
635-2-11	PULL & SPLICE BOX, F&I, 13" x 24" COVER SIZE	EA																
654-2-21	RECTANGULAR RAPID FLASHING BEACON, F&I - SOLAR POWERED, COMPLETE SIGN ASSEMBLY - SINGLE DIRECTION	AS																
700-1-11	SINGLE POST SIGN, F&I GROUND MOUNT, UP TO 12 SF	AS	2		8		7						4		1		22	
700-1-12	SINGLE POST SIGN, F&I GROUND MOUNT, 12-20 SF	AS	2		2		1		2		2				2		11	
700-1-13	SINGLE POST SIGN, F&I GROUND MOUNT, 21-30 SF	AS			2		1		2								5	
700-1-50	SINGLE POST SIGN, RELOCATE	AS			1												1	
700-1-60	SINGLE POST SIGN, REMOVE	AS	2		6		1		6				1		2		18	
700-2-12	MULTI-POST SIGN, F&I GROUND MOUNT, 12-20 SF	AS																
700-2-15	MULTI-POST SIGN, F&I GROUND MOUNT, 51-100SF	AS																
700-12-21	SIGN BEACON, F&I GROUND MOUNT- SOLAR POWERED, ONE BEACON	AS																
701-1-101	PROFILED THERMOPLASTIC, STANDARD, WHITE, SOLID, 6"	GM																
701-1-201	PROFILED THERMOPLASTIC, STANDARD, YELLOW, SOLID, 6"	GM																
705-11-1	DELINEATOR, FLEXIBLE TUBULAR	EA					2		2				1		3		8	
706-1-3	RAISED PAVEMENT MARKER, TYPE B	EA																
	WHITE/RED				29		65		42		38		37		62		273	
	YELLOW/YELLOW		8		90		70		32				16		32		248	
710-12-290	PAINTED PAVEMENT MARKINGS, DURABLE PAINT, YELLOW, ISLAND NOSE	SF					43.0		14.7				7.4		14.7		79.8	
710-90	PAINTED PAVEMENT MARKINGS, FINAL SURFACE	LS																
*	PAINTED PAVEMENT MARKINGS, STD, WHITE, SOLID, 6"	GM	0.038		0.240		0.248		0.278		0.276		0.267		0.331		1.678	
*	PAINTED PAVEMENT MARKINGS, STD, WHITE, SOLID FOR INTERCHANGE AND URBAN ISLAND, 8"	GM			0.113		0.012								0.020		0.145	
*	PAINTED PAVEMENT MARKINGS, STD, WHITE, SOLID FOR CROSSWALK AND ROUNDABOUT, 12"	LF			140		81		171				162		202		756	
*	PAINTED PAVEMENT MARKINGS, STD, WHITE, SOLID FOR DIAGONAL OR CHEVRON, 18"	LF			92												92	
*	PAINTED PAVEMENT MARKINGS, STD, WHITE, SOLID FOR STOPLINE OR CROSSWALK, 24"	LF			86		95		109						177		467	
*	PAINTED PAVEMENT MARKINGS, STD, WHITE, SKIP, 10-30 OR 3-9 SKIP, 6" WIDE	GM			0.025		0.133		0.226		0.265		0.233		0.243		1.125	
*	PAINTED PAVEMENT MARKING, STD, WHITE, 3'-9" SKIP DROP LINE AND APPROACH TO TOLL PLAZA, 12" WIDE,	GM					0.100										0.100	
*	PAINTED PAVEMENT MARKINGS, STD, WHITE, 2-4 DOTTED GUIDELINE / 6-10 DOTTED EXT., 6"	GM			0.030				0.015		0.015		0.016		0.032		0.108	
*	PAINTED PAVEMENT MARKINGS, STD, WHITE, 2-2 DOTTED EXTENSION FOR ROUNDABOUT, 12"	GM																
*	PAINTED PAVEMENT MARKINGS, STD, WHITE, ARROW	EA			4		1		5		1		2		7		20	
*	PAINTED PAVEMENT MARKINGS, STD, WHITE, MESSAGE	EA			4		1										5	
*	PAINTED PAVEMENT MARKINGS, STD, YELLOW, SOLID 6"	GM	0.038		0.449		0.244		0.265		0.265		0.210		0.265		1.736	
*	PAINTED PAVEMENT MARKINGS, STD, YELLOW, SOLID, 18" FOR DIAGONALS AND CHEVRONS	LF			275										78		353	
*	PAINTED PAVEMENT MARKINGS, STD, YELLOW, 2-4 DOTTED GUIDELINE/6-10 DOTTED EXTENSION, 6"	GM			0.027		0.041		0.038				0.055				0.161	
711-11-123	THERMOPLASTIC, STD, WHITE, SOLID, 12" FOR CROSSWALK AND ROUNDABOUT	LF			81				82				162				325	
711-11-124	THERMOPLASTIC, STD, WHITE, SOLID, 18" FOR DIAGONALS AND CHEVRONS	LF			92												92	
711-11-125	THERMOPLASTIC, STD, WHITE, SOLID, 24" FOR STOP LINE AND CROSSWALK	LF			31		13		30						15		89	
711-11-141	THERMOPLASTIC, STD., WHITE, 2-4 DOTTED GUIDE LINE/ 6-10 DOTTED EXT., 6"	GM			0.030				0.015		0.015		0.016		0.032		0.108	
711-11-144	THERMOPLASTIC, STANDARD, WHITE, 2-2 DOTTED EXTENSION LINE, 12" FOR ROUNDABOUT	GM																
711-11-160	THERMOPLASTIC, STD, WHITE, MESSAGE OR SYMBOL	EA			4		1										5	
711-11-170	THERMOPLASTIC, STD, WHITE, ARROWS	EA			4		1		5		1		2		7		20	
711-11-224	THERMOPLASTIC, STD, YELLOW, SOLID, 18" FOR DIAGONAL OR CHEVRON	LF			275										78		353	
711-11-241	THERMOPLASTIC, STD., YELLOW, 2-4 DOTTED GUIDE LINE/ 6-10 DOTTED EXT., 6"	GM			0.027		0.033		0.033				0.051				0.144	
711-14-123	THERMOPLASTIC, PREFORMED, WHITE, SOLID, 12" FOR CROSSWALK	LF			59		81		89						202		431	
711-14-125	THERMOPLASTIC, PREFORMED, WHITE, SOLID, 24" FOR CROSSWALK	LF			55		82		79						162		378	
711-15-101	THERMOPLASTIC, STANDARD-OPEN GRADED ASPHALT SURFACES WHITE, SOLID, 6"	GM																
711-15-102	THERMOPLASTIC, STANDARD-OPEN GRADED ASPHALT SURFACES, WHITE, SOLID, 8"	GM																
711-15-131	THERMOPLASTIC, STANDARD-OPEN GRADED ASPHALT SURFACES, WHITE, SKIP, 6", 10-30 SKIP OR 3-9 LANE DROP	GM																
711-15-201	THERMOPLASTIC, STANDARD-OPEN GRADED ASPHALT SURFACES, YELLOW, SOLID, 6"	GM																
711-16-101	THERMOPLASTIC, STANDARD-OTHER SURFACES, WHITE, SOLID, 6"	GM	0.038		0.240		0.248		0.278		0.276		0.267		0.331		1.678	
711-16-102	THERMOPLASTIC, STANDARD-OTHER SURFACES, WHITE, SOLID, 8"	GM			0.113		0.012								0.020		0.145	
711-16-131	THERMOPLASTIC, STANDARD-OTHER SURFACES, WHITE, SKIP, 6", 10-30 SKIP OR 3-9 LANE DROP	GM			0.025		0.133		0.226		0.265		0.233		0.243		1.125	
711-16-133	THERMOPLASTIC, STANDARD-OTHER SURFACES WHITE, SKIP, 12"- APPROACH TO TOLL PLAZA OR 3-9 LANE DROP	GM					0.100										0.100	
711-16-201	THERMOPLASTIC, STANDARD-OTHER SURFACES, YELLOW, SOLID, 6"	GM	0.038		0.449		0.244		0.265		0.265		0.210		0.265		1.736	

PAY ITEM NOTES

\* THESE QUANTITIES ARE PAID FOR UNDER PAINTED PAVEMENT MARKINGS (FINAL SURFACE), LUMP SUM - ITEM NO. 710-90. THE QUANTITIES SHOWN ARE FOR ONE APPLICATION; SEE SPECIFICATION 710 FOR THE NUMBER OF APPLICATIONS REQUIRED.

REVISIONS				JAMES E. BRADFORD, P.E. P.E. LICENSE NUMBER 68276 DEWBERRY ENGINEERS INC. 800 NORTH MAGNOLIA AVENUE, STE. 1000 ORLANDO, FL 32803	POLK COUNTY PUBLIC WORKS DEPARTMENT			TABULATION OF QUANTITIES	SHEET NO.  S-2
DATE	DESCRIPTION	DATE	DESCRIPTION		ROAD NO.	COUNTY	FINANCIAL PROJECT ID		
					557	POLK	18-73		

THE OFFICIAL RECORD OF THIS SHEET IS THE ELECTRONIC FILE DIGITALLY SIGNED AND SEALED UNDER RULE 61G15-23.004, F.A.C.

TABULATION OF QUANTITIES

PAY ITEM NO.	DESCRIPTION	UNIT	SHEET NUMBERS														TOTAL THIS SHEET	
			S-18		S-19		S-20		S-21		S-22		S-23		S-24		PLAN	FINAL
			PLAN	FINAL	PLAN	FINAL	PLAN	FINAL	PLAN	FINAL	PLAN	FINAL	PLAN	FINAL	PLAN	FINAL		
630-2-11	CONDUIT, F&I, OPEN TRENCH	LF																
635-2-11	PULL & SPLICE BOX, F&I, 13" x 24" COVER SIZE	EA																
654-2-21	RECTANGULAR RAPID FLASHING BEACON, F&I - SOLAR POWERED, COMPLETE SIGN ASSEMBLY - SINGLE DIRECTION	AS																
700-1-11	SINGLE POST SIGN, F&I GROUND MOUNT, UP TO 12 SF	AS			7				4				4				15	
700-1-12	SINGLE POST SIGN, F&I GROUND MOUNT, 12-20 SF	AS	1		1				1				2				5	
700-1-13	SINGLE POST SIGN, F&I GROUND MOUNT, 21-30 SF	AS							1								1	
700-1-50	SINGLE POST SIGN, RELOCATE	AS									1						1	
700-1-60	SINGLE POST SIGN, REMOVE	AS			3		4		5		1		2				15	
700-2-12	MULTI-POST SIGN, F&I GROUND MOUNT, 12-20 SF	AS	1				1										2	
700-2-15	MULTI-POST SIGN, F&I GROUND MOUNT, 51-100SF	AS																
700-12-21	SIGN BEACON, F&I GROUND MOUNT- SOLAR POWERED, ONE BEACON	AS																
701-1-101	PROFILED THERMOPLASTIC, STANDARD, WHITE, SOLID, 6"	GM																
701-1-201	PROFILED THERMOPLASTIC, STANDARD, YELLOW, SOLID, 6"	GM																
705-11-1	DELINEATOR, FLEXIBLE TUBULAR	EA							2				2				4	
706-1-3	RAISED PAVEMENT MARKER, TYPE B	EA																
	WHITE/RED		72		78		50		49		34		56		35		374	
	YELLOW/YELLOW				32				32				35				99	
710-12-290	PAINTED PAVEMENT MARKINGS, DURABLE PAINT, YELLOW, ISLAND NOSE	SF			14.7				14.7				23.1				52.5	
710-90	PAINTED PAVEMENT MARKINGS, FINAL SURFACE	LS																
*	PAINTED PAVEMENT MARKINGS, STD, WHITE, SOLID, 6"	GM	0.415		0.460		0.323		0.324		0.265		0.340		0.265		2.392	
*	PAINTED PAVEMENT MARKINGS, STD, WHITE, SOLID FOR INTERCHANGE AND URBAN ISLAND, 8"	GM			0.024												0.024	
*	PAINTED PAVEMENT MARKINGS, STD, WHITE, SOLID FOR CROSSWALK AND ROUNDABOUT, 12"	LF			280				76				144				500	
*	PAINTED PAVEMENT MARKINGS, STD, WHITE, SOLID FOR DIAGONAL OR CHEVRON, 18"	LF																
*	PAINTED PAVEMENT MARKINGS, STD, WHITE, SOLID FOR STOPLINE OR CROSSWALK, 24"	LF			337				13				166				516	
*	PAINTED PAVEMENT MARKINGS, STD, WHITE, SKIP, 10-30 OR 3-9 SKIP, 6" WIDE	GM	0.246		0.153		0.265		0.246		0.265		0.265		0.265		1.705	
*	PAINTED PAVEMENT MARKING, STD, WHITE, 3'-9" SKIP DROP LINE AND APPROACH TO TOLL PLAZA, 12" WIDE,	GM																
*	PAINTED PAVEMENT MARKINGS, STD, WHITE, 2-4 DOTTED GUIDELINE / 6-10 DOTTED EXT., 6"	GM	0.048				0.048		0.016		0.009		0.024				0.145	
*	PAINTED PAVEMENT MARKINGS, STD, WHITE, 2-2 DOTTED EXTENSION FOR ROUNDABOUT, 12"	GM																
*	PAINTED PAVEMENT MARKINGS, STD, WHITE, ARROW	EA	10		11		5		5				6				37	
*	PAINTED PAVEMENT MARKINGS, STD, WHITE, MESSAGE	EA			1												1	
*	PAINTED PAVEMENT MARKINGS, STD, YELLOW, SOLID 6"	GM	0.266		0.258		0.266		0.249		0.265		0.231		0.265		1.800	
*	PAINTED PAVEMENT MARKINGS, STD, YELLOW, SOLID, 18" FOR DIAGONALS AND CHEVRONS	LF																
*	PAINTED PAVEMENT MARKINGS, STD, YELLOW, 2-4 DOTTED GUIDELINE/6-10 DOTTED EXTENSION, 6"	GM			0.039				0.036				0.057				0.132	
711-11-123	THERMOPLASTIC, STD, WHITE, SOLID, 12" FOR CROSSWALK AND ROUNDABOUT	LF							76								76	
711-11-124	THERMOPLASTIC, STD, WHITE, SOLID, 18" FOR DIAGONALS AND CHEVRONS	LF																
711-11-125	THERMOPLASTIC, STD, WHITE, SOLID, 24" FOR STOP LINE AND CROSSWALK	LF			109				13				27				149	
711-11-141	THERMOPLASTIC, STD., WHITE, 2-4 DOTTED GUIDE LINE/ 6-10 DOTTED EXT., 6"	GM	0.048				0.048		0.016		0.009		0.024				0.145	
711-11-144	THERMOPLASTIC, STANDARD, WHITE, 2-2 DOTTED EXTENSION LINE, 12" FOR ROUNDABOUT	GM																
711-11-160	THERMOPLASTIC, STD, WHITE, MESSAGE OR SYMBOL	EA			1												1	
711-11-170	THERMOPLASTIC, STD, WHITE, ARROWS	EA	10		11		5		5				6				37	
711-11-224	THERMOPLASTIC, STD, YELLOW, SOLID, 18" FOR DIAGONAL OR CHEVRON	LF																
711-11-241	THERMOPLASTIC, STD., YELLOW, 2-4 DOTTED GUIDE LINE/ 6-10 DOTTED EXT., 6"	GM			0.039				0.033				0.051				0.123	
711-14-123	THERMOPLASTIC, PREFORMED, WHITE, SOLID, 12" FOR CROSSWALK	LF			280								144				424	
711-14-125	THERMOPLASTIC, PREFORMED, WHITE, SOLID, 24" FOR CROSSWALK	LF			228								139				367	
711-15-101	THERMOPLASTIC, STANDARD-OPEN GRADED ASPHALT SURFACES WHITE, SOLID, 6"	GM																
711-15-102	THERMOPLASTIC, STANDARD-OPEN GRADED ASPHALT SURFACES, WHITE, SOLID, 8"	GM																
711-15-131	THERMOPLASTIC, STANDARD-OPEN GRADED ASPHALT SURFACES, WHITE, SKIP, 6", 10-30 SKIP OR 3-9 LANE DROP	GM																
711-15-201	THERMOPLASTIC, STANDARD-OPEN GRADED ASPHALT SURFACES, YELLOW, SOLID, 6"	GM																
711-16-101	THERMOPLASTIC, STANDARD-OTHER SURFACES, WHITE, SOLID, 6"	GM	0.415		0.460		0.323		0.324		0.265		0.340		0.265		2.392	
711-16-102	THERMOPLASTIC, STANDARD-OTHER SURFACES, WHITE, SOLID, 8"	GM			0.024												0.024	
711-16-131	THERMOPLASTIC, STANDARD-OTHER SURFACES, WHITE, SKIP, 6", 10-30 SKIP OR 3-9 LANE DROP	GM	0.246		0.153		0.265		0.246		0.265		0.265		0.265		1.705	
711-16-133	THERMOPLASTIC, STANDARD-OTHER SURFACES WHITE, SKIP, 12"- APPROACH TO TOLL PLAZA OR 3-9 LANE DROP	GM																
711-16-201	THERMOPLASTIC, STANDARD-OTHER SURFACES, YELLOW, SOLID, 6"	GM	0.266		0.258		0.266		0.249		0.265		0.231		0.265		1.800	

REVISIONS				JAMES E. BRADFORD, P.E. P.E. LICENSE NUMBER 68276 DEWBERRY ENGINEERS INC. 800 NORTH MAGNOLIA AVENUE, STE. 1000 ORLANDO, FL 32803	POLK COUNTY PUBLIC WORKS DEPARTMENT			TABULATION OF QUANTITIES	SHEET NO.
DATE	DESCRIPTION	DATE	DESCRIPTION		ROAD NO.	COUNTY	FINANCIAL PROJECT ID		
					557	POLK	18-73		S-3

THE OFFICIAL RECORD OF THIS SHEET IS THE ELECTRONIC FILE DIGITALLY SIGNED AND SEALED UNDER RULE 61G15-23.004, F.A.C.

TABULATION OF QUANTITIES

PAY ITEM NO.	DESCRIPTION	UNIT	SHEET NUMBERS														TOTAL THIS SHEET	
			S-25		S-26		S-27		S-28		S-29		S-30		S-31		PLAN	FINAL
			PLAN	FINAL	PLAN	FINAL	PLAN	FINAL	PLAN	FINAL	PLAN	FINAL	PLAN	FINAL	PLAN	FINAL		
630-2-11	CONDUIT, F&I, OPEN TRENCH	LF																
635-2-11	PULL & SPLICE BOX, F&I, 13" x 24" COVER SIZE	EA																
654-2-21	RECTANGULAR RAPID FLASHING BEACON, F&I - SOLAR POWERED, COMPLETE SIGN ASSEMBLY - SINGLE DIRECTION	AS																
700-1-11	SINGLE POST SIGN, F&I GROUND MOUNT, UP TO 12 SF	AS																
700-1-12	SINGLE POST SIGN, F&I GROUND MOUNT, 12-20 SF	AS																
700-1-13	SINGLE POST SIGN, F&I GROUND MOUNT, 21-30 SF	AS																
700-1-50	SINGLE POST SIGN, RELOCATE	AS																
700-1-60	SINGLE POST SIGN, REMOVE	AS	2							2								4
700-2-12	MULTI-POST SIGN, F&I GROUND MOUNT, 12-20 SF	AS																
700-2-15	MULTI-POST SIGN, F&I GROUND MOUNT, 51-100SF	AS																
700-12-21	SIGN BEACON, F&I GROUND MOUNT- SOLAR POWERED, ONE BEACON	AS																
701-1-101	PROFILED THERMOPLASTIC, STANDARD, WHITE, SOLID, 6"	GM																
701-1-201	PROFILED THERMOPLASTIC, STANDARD, YELLOW, SOLID, 6"	GM																
705-11-1	DELINEATOR, FLEXIBLE TUBULAR	EA			2				1		1							4
706-1-3	RAISED PAVEMENT MARKER, TYPE B	EA																
	WHITE/RED		35		55		35		46		52		35		35			293
	YELLOW/YELLOW				32						32							64
710-12-290	PAINTED PAVEMENT MARKINGS, DURABLE PAINT, YELLOW, ISLAND NOSE	SF			14.7						14.7							29.4
710-90	PAINTED PAVEMENT MARKINGS, FINAL SURFACE	LS																
*	PAINTED PAVEMENT MARKINGS, STD, WHITE, SOLID, 6"	GM	0.267		0.340		0.265		0.303		0.334		0.265		0.265			2.039
*	PAINTED PAVEMENT MARKINGS, STD, WHITE, SOLID FOR INTERCHANGE AND URBAN ISLAND, 8"	GM																
*	PAINTED PAVEMENT MARKINGS, STD, WHITE, SOLID FOR CROSSWALK AND ROUNDABOUT, 12"	LF																
*	PAINTED PAVEMENT MARKINGS, STD, WHITE, SOLID FOR DIAGONAL OR CHEVRON, 18"	LF																
*	PAINTED PAVEMENT MARKINGS, STD, WHITE, SOLID FOR STOPLINE OR CROSSWALK, 24"	LF																
*	PAINTED PAVEMENT MARKINGS, STD, WHITE, SKIP, 10-30 OR 3-9 SKIP, 6" WIDE	GM	0.265		0.265		0.265		0.265		0.265		0.265		0.265			1.855
*	PAINTED PAVEMENT MARKING, STD, WHITE, 3'-9" SKIP DROP LINE AND APPROACH TO TOLL PLAZA, 12" WIDE,	GM																
*	PAINTED PAVEMENT MARKINGS, STD, WHITE, 2-4 DOTTED GUIDELINE / 6-10 DOTTED EXT., 6"	GM	0.016		0.016				0.016		0.016							0.064
*	PAINTED PAVEMENT MARKINGS, STD, WHITE, 2-2 DOTTED EXTENSION FOR ROUNDABOUT, 12"	GM																
*	PAINTED PAVEMENT MARKINGS, STD, WHITE, ARROW	EA			6				3		5							14
*	PAINTED PAVEMENT MARKINGS, STD, WHITE, MESSAGE	EA																
*	PAINTED PAVEMENT MARKINGS, STD, YELLOW, SOLID 6"	GM	0.266		0.224		0.265		0.265		0.228		0.265		0.265			1.778
*	PAINTED PAVEMENT MARKINGS, STD, YELLOW, SOLID, 18" FOR DIAGONALS AND CHEVRONS	LF																
*	PAINTED PAVEMENT MARKINGS, STD, YELLOW, 2-4 DOTTED GUIDELINE/6-10 DOTTED EXTENSION, 6"	GM			0.042						0.038							0.080
711-11-123	THERMOPLASTIC, STD, WHITE, SOLID, 12" FOR CROSSWALK AND ROUNDABOUT	LF																
711-11-124	THERMOPLASTIC, STD, WHITE, SOLID, 18" FOR DIAGONALS AND CHEVRONS	LF																
711-11-125	THERMOPLASTIC, STD, WHITE, SOLID, 24" FOR STOP LINE AND CROSSWALK	LF																
711-11-141	THERMOPLASTIC, STD., WHITE, 2-4 DOTTED GUIDE LINE/ 6-10 DOTTED EXT., 6"	GM	0.016		0.016				0.016		0.016							0.064
711-11-144	THERMOPLASTIC, STANDARD, WHITE, 2-2 DOTTED EXTENSION LINE, 12" FOR ROUNDABOUT	GM																
711-11-160	THERMOPLASTIC, STD, WHITE, MESSAGE OR SYMBOL	EA																
711-11-170	THERMOPLASTIC, STD, WHITE, ARROWS	EA			6				3		5							14
711-11-224	THERMOPLASTIC, STD, YELLOW, SOLID, 18" FOR DIAGONAL OR CHEVRON	LF																
711-11-241	THERMOPLASTIC, STD., YELLOW, 2-4 DOTTED GUIDE LINE/ 6-10 DOTTED EXT., 6"	GM			0.042						0.038							0.080
711-14-123	THERMOPLASTIC, PREFORMED, WHITE, SOLID, 12" FOR CROSSWALK	LF																
711-14-125	THERMOPLASTIC, PREFORMED, WHITE, SOLID, 24" FOR CROSSWALK	LF																
711-15-101	THERMOPLASTIC, STANDARD-OPEN GRADED ASPHALT SURFACES WHITE, SOLID, 6"	GM																
711-15-102	THERMOPLASTIC, STANDARD-OPEN GRADED ASPHALT SURFACES, WHITE, SOLID, 8"	GM																
711-15-131	THERMOPLASTIC, STANDARD-OPEN GRADED ASPHALT SURFACES, WHITE, SKIP, 6", 10-30 SKIP OR 3-9 LANE DROP	GM																
711-15-201	THERMOPLASTIC, STANDARD-OPEN GRADED ASPHALT SURFACES, YELLOW, SOLID, 6"	GM																
711-16-101	THERMOPLASTIC, STANDARD-OTHER SURFACES, WHITE, SOLID, 6"	GM	0.267		0.340		0.265		0.303		0.334		0.265		0.265			2.039
711-16-102	THERMOPLASTIC, STANDARD-OTHER SURFACES, WHITE, SOLID, 8"	GM																
711-16-131	THERMOPLASTIC, STANDARD-OTHER SURFACES, WHITE, SKIP, 6", 10-30 SKIP OR 3-9 LANE DROP	GM	0.265		0.265		0.265		0.265		0.265		0.265		0.265			1.855
711-16-133	THERMOPLASTIC, STANDARD-OTHER SURFACES WHITE, SKIP, 12"- APPROACH TO TOLL PLAZA OR 3-9 LANE DROP	GM																
711-16-201	THERMOPLASTIC, STANDARD-OTHER SURFACES, YELLOW, SOLID, 6"	GM	0.266		0.224		0.265		0.265		0.228		0.265		0.265			1.778

REVISIONS				JAMES E. BRADFORD, P.E. P.E. LICENSE NUMBER 68276 DEWBERRY ENGINEERS INC. 800 NORTH MAGNOLIA AVENUE, STE. 1000 ORLANDO, FL 32803	POLK COUNTY PUBLIC WORKS DEPARTMENT			TABULATION OF QUANTITIES	SHEET NO.
DATE	DESCRIPTION	DATE	DESCRIPTION		ROAD NO.	COUNTY	FINANCIAL PROJECT ID		
					557	POLK	18-73		S-4

THE OFFICIAL RECORD OF THIS SHEET IS THE ELECTRONIC FILE DIGITALLY SIGNED AND SEALED UNDER RULE 61G15-23.004, F.A.C.

TABULATION OF QUANTITIES

PAY ITEM NO.	DESCRIPTION	UNIT	SHEET NUMBERS														TOTAL THIS SHEET	
			S-32		S-33		S-34		S-35		S-36		S-37		S-38		PLAN	FINAL
			PLAN	FINAL	PLAN	FINAL	PLAN	FINAL	PLAN	FINAL	PLAN	FINAL	PLAN	FINAL	PLAN	FINAL		
630-2-11	CONDUIT, F&I, OPEN TRENCH	LF															205	205
635-2-11	PULL & SPLICE BOX, F&I, 13" x 24" COVER SIZE	EA															8	8
654-2-21	RECTANGULAR RAPID FLASHING BEACON, F&I - SOLAR POWERED, COMPLETE SIGN ASSEMBLY - SINGLE DIRECTION	AS															8	8
700-1-11	SINGLE POST SIGN, F&I GROUND MOUNT, UP TO 12 SF	AS	4				4						5				8	21
700-1-12	SINGLE POST SIGN, F&I GROUND MOUNT, 12-20 SF	AS	2		1		1			1		4					2	11
700-1-13	SINGLE POST SIGN, F&I GROUND MOUNT, 21-30 SF	AS			1		1					1					1	4
700-1-50	SINGLE POST SIGN, RELOCATE	AS																
700-1-60	SINGLE POST SIGN, REMOVE	AS	2				3		3		5		8				2	23
700-2-12	MULTI-POST SIGN, F&I GROUND MOUNT, 12-20 SF	AS																
700-2-15	MULTI-POST SIGN, F&I GROUND MOUNT, 51-100SF	AS											1					1
700-12-21	SIGN BEACON, F&I GROUND MOUNT- SOLAR POWERED, ONE BEACON	AS											2					2
701-1-101	PROFILED THERMOPLASTIC, STANDARD, WHITE, SOLID, 6"	GM																
701-1-201	PROFILED THERMOPLASTIC, STANDARD, YELLOW, SOLID, 6"	GM																
705-11-1	DELINEATOR, FLEXIBLE TUBULAR	EA	7		1		2				1		1					12
706-1-3	RAISED PAVEMENT MARKER, TYPE B	EA																
	WHITE/RED		38		47		50		35		45		54		59			328
	YELLOW/YELLOW		16		16		32				16		16					96
710-12-290	PAINTED PAVEMENT MARKINGS, DURABLE PAINT, YELLOW, ISLAND NOSE	SF	35.5		7.4		14.7				7.4		7.4					72.4
710-90	PAINTED PAVEMENT MARKINGS, FINAL SURFACE	LS																
*	PAINTED PAVEMENT MARKINGS, STD, WHITE, SOLID, 6"	GM	0.268		0.309		0.321		0.265		0.299		0.346		0.428			2.236
*	PAINTED PAVEMENT MARKINGS, STD, WHITE, SOLID FOR INTERCHANGE AND URBAN ISLAND, 8"	GM	0.015		0.002										0.061			0.078
*	PAINTED PAVEMENT MARKINGS, STD, WHITE, SOLID FOR CROSSWALK AND ROUNDABOUT, 12"	LF	91				92						105		180			468
*	PAINTED PAVEMENT MARKINGS, STD, WHITE, SOLID FOR DIAGONAL OR CHEVRON, 18"	LF	2												57			59
*	PAINTED PAVEMENT MARKINGS, STD, WHITE, SOLID FOR STOPLINE OR CROSSWALK, 24"	LF	14				16						145		170			345
*	PAINTED PAVEMENT MARKINGS, STD, WHITE, SKIP, 10-30 OR 3-9 SKIP, 6" WIDE	GM	0.251		0.263		0.240		0.265		0.265		0.260					1.544
*	PAINTED PAVEMENT MARKING, STD, WHITE, 3'-9" SKIP DROP LINE AND APPROACH TO TOLL PLAZA, 12" WIDE,	GM																
*	PAINTED PAVEMENT MARKINGS, STD, WHITE, 2-4 DOTTED GUIDELINE / 6-10 DOTTED EXT., 6"	GM			0.032		0.016				0.016		0.032		0.059			0.155
*	PAINTED PAVEMENT MARKINGS, STD, WHITE, 2-2 DOTTED EXTENSION FOR ROUNDABOUT, 12"	GM													0.022			0.022
*	PAINTED PAVEMENT MARKINGS, STD, WHITE, ARROW	EA			4		5				3		10		16			38
*	PAINTED PAVEMENT MARKINGS, STD, WHITE, MESSAGE	EA													4			4
*	PAINTED PAVEMENT MARKINGS, STD, YELLOW, SOLID 6"	GM	0.262		0.261		0.240		0.265		0.258		0.258		0.313			1.857
*	PAINTED PAVEMENT MARKINGS, STD, YELLOW, SOLID, 18" FOR DIAGONALS AND CHEVRONS	LF																
*	PAINTED PAVEMENT MARKINGS, STD, YELLOW, 2-4 DOTTED GUIDELINE/6-10 DOTTED EXTENSION, 6"	GM									0.008		0.038					0.046
711-11-123	THERMOPLASTIC, STD, WHITE, SOLID, 12" FOR CROSSWALK AND ROUNDABOUT	LF	91				92											183
711-11-124	THERMOPLASTIC, STD, WHITE, SOLID, 18" FOR DIAGONALS AND CHEVRONS	LF	2												57			59
711-11-125	THERMOPLASTIC, STD, WHITE, SOLID, 24" FOR STOP LINE AND CROSSWALK	LF	14				16						49					79
711-11-141	THERMOPLASTIC, STD., WHITE, 2-4 DOTTED GUIDE LINE/ 6-10 DOTTED EXT., 6"	GM			0.032		0.016				0.016		0.032		0.059			0.155
711-11-144	THERMOPLASTIC, STANDARD, WHITE, 2-2 DOTTED EXTENSION LINE, 12" FOR ROUNDABOUT	GM													0.022			0.022
711-11-160	THERMOPLASTIC, STD, WHITE, MESSAGE OR SYMBOL	EA													4			4
711-11-170	THERMOPLASTIC, STD, WHITE, ARROWS	EA			4		5				3		10		16			38
711-11-224	THERMOPLASTIC, STD, YELLOW, SOLID, 18" FOR DIAGONAL OR CHEVRON	LF																
711-11-241	THERMOPLASTIC, STD., YELLOW, 2-4 DOTTED GUIDE LINE/ 6-10 DOTTED EXT., 6"	GM									0.008		0.038					0.046
711-14-123	THERMOPLASTIC, PREFORMED, WHITE, SOLID, 12" FOR CROSSWALK	LF											105		180			285
711-14-125	THERMOPLASTIC, PREFORMED, WHITE, SOLID, 24" FOR CROSSWALK	LF											96		170			266
711-15-101	THERMOPLASTIC, STANDARD-OPEN GRADED ASPHALT SURFACES WHITE, SOLID, 6"	GM																
711-15-102	THERMOPLASTIC, STANDARD-OPEN GRADED ASPHALT SURFACES, WHITE, SOLID, 8"	GM																
711-15-131	THERMOPLASTIC, STANDARD-OPEN GRADED ASPHALT SURFACES, WHITE, SKIP, 6", 10-30 SKIP OR 3-9 LANE DROP	GM																
711-15-201	THERMOPLASTIC, STANDARD-OPEN GRADED ASPHALT SURFACES, YELLOW, SOLID, 6"	GM																
711-16-101	THERMOPLASTIC, STANDARD-OTHER SURFACES, WHITE, SOLID, 6"	GM	0.268		0.309		0.321		0.265		0.299		0.346		0.428			2.236
711-16-102	THERMOPLASTIC, STANDARD-OTHER SURFACES, WHITE, SOLID, 8"	GM	0.015		0.002										0.061			0.078
711-16-131	THERMOPLASTIC, STANDARD-OTHER SURFACES, WHITE, SKIP, 6", 10-30 SKIP OR 3-9 LANE DROP	GM	0.251		0.263		0.240		0.265		0.265		0.260					1.544
711-16-133	THERMOPLASTIC, STANDARD-OTHER SURFACES WHITE, SKIP, 12"- APPROACH TO TOLL PLAZA OR 3-9 LANE DROP	GM																
711-16-201	THERMOPLASTIC, STANDARD-OTHER SURFACES, YELLOW, SOLID, 6"	GM	0.262		0.261		0.240		0.265		0.258		0.258		0.313			1.857

REVISIONS				JAMES E. BRADFORD, P.E. P.E. LICENSE NUMBER 68276 DEWBERRY ENGINEERS INC. 800 NORTH MAGNOLIA AVENUE, STE. 1000 ORLANDO, FL 32803	POLK COUNTY PUBLIC WORKS DEPARTMENT			TABULATION OF QUANTITIES	SHEET NO.
DATE	DESCRIPTION	DATE	DESCRIPTION		ROAD NO.	COUNTY	FINANCIAL PROJECT ID		
					557	POLK	18-73		S-5

THE OFFICIAL RECORD OF THIS SHEET IS THE ELECTRONIC FILE DIGITALLY SIGNED AND SEALED UNDER RULE 61G15-23.004, F.A.C.

TABULATION OF QUANTITIES

PAY ITEM NO.	DESCRIPTION	UNIT	SHEET NUMBERS														TOTAL THIS SHEET	
			S-39		S-40		S-41		S-42		S-43		S-44		S-45		PLAN	FINAL
			PLAN	FINAL	PLAN	FINAL	PLAN	FINAL	PLAN	FINAL	PLAN	FINAL	PLAN	FINAL	PLAN	FINAL		
630-2-11	CONDUIT, F&I, OPEN TRENCH	LF	110														110	
635-2-11	PULL & SPLICE BOX, F&I, 13" x 24" COVER SIZE	EA	4														4	
654-2-21	RECTANGULAR RAPID FLASHING BEACON, F&I - SOLAR POWERED, COMPLETE SIGN ASSEMBLY - SINGLE DIRECTION	AS	4														4	
700-1-11	SINGLE POST SIGN, F&I GROUND MOUNT, UP TO 12 SF	AS	4		1				4								9	
700-1-12	SINGLE POST SIGN, F&I GROUND MOUNT, 12-20 SF	AS	4		2				1								7	
700-1-13	SINGLE POST SIGN, F&I GROUND MOUNT, 21-30 SF	AS							1								1	
700-1-50	SINGLE POST SIGN, RELOCATE	AS																
700-1-60	SINGLE POST SIGN, REMOVE	AS			1				2		1						4	
700-2-12	MULTI-POST SIGN, F&I GROUND MOUNT, 12-20 SF	AS																
700-2-15	MULTI-POST SIGN, F&I GROUND MOUNT, 51-100SF	AS			1												1	
700-12-21	SIGN BEACON, F&I GROUND MOUNT- SOLAR POWERED, ONE BEACON	AS			2												2	
701-1-101	PROFILED THERMOPLASTIC, STANDARD, WHITE, SOLID, 6"	GM	0.038		0.265			0.265	0.242		0.265			0.265		0.265	1.605	
701-1-201	PROFILED THERMOPLASTIC, STANDARD, YELLOW, SOLID, 6"	GM	0.038		0.265			0.196	0.105		0.246			0.175		0.124	1.149	
705-11-1	DELINEATOR, FLEXIBLE TUBULAR	EA							2							2	4	
706-1-3	RAISED PAVEMENT MARKER, TYPE B	EA																
	WHITE/RED		66		35			47	56		36			52		56	348	
	YELLOW/YELLOW								88							88	176	
710-12-290	PAINTED PAVEMENT MARKINGS, DURABLE PAINT, YELLOW, ISLAND NOSE	SF																
710-90	PAINTED PAVEMENT MARKINGS, FINAL SURFACE	LS																
*	PAINTED PAVEMENT MARKINGS, STD, WHITE, SOLID, 6"	GM	0.370		0.265			0.312	0.341		0.266			0.331		0.345	2.230	
*	PAINTED PAVEMENT MARKINGS, STD, WHITE, SOLID FOR INTERCHANGE AND URBAN ISLAND, 8"	GM	0.047														0.047	
*	PAINTED PAVEMENT MARKINGS, STD, WHITE, SOLID FOR CROSSWALK AND ROUNDABOUT, 12"	LF	120														120	
*	PAINTED PAVEMENT MARKINGS, STD, WHITE, SOLID FOR DIAGONAL OR CHEVRON, 18"	LF	66														66	
*	PAINTED PAVEMENT MARKINGS, STD, WHITE, SOLID FOR STOPLINE OR CROSSWALK, 24"	LF	110						31								141	
*	PAINTED PAVEMENT MARKINGS, STD, WHITE, SKIP, 10-30 OR 3-9 SKIP, 6" WIDE	GM	0.131		0.265			0.265	0.232		0.265			0.265		0.265	1.688	
*	PAINTED PAVEMENT MARKING, STD, WHITE, 3'-9" SKIP DROP LINE AND APPROACH TO TOLL PLAZA, 12" WIDE,	GM						0.024	0.005		0.019			0.024		0.024	0.110	
*	PAINTED PAVEMENT MARKINGS, STD, WHITE, 2-4 DOTTED GUIDELINE / 6-10 DOTTED EXT., 6"	GM	0.014														0.003	
*	PAINTED PAVEMENT MARKINGS, STD, WHITE, 2-2 DOTTED EXTENSION FOR ROUNDABOUT, 12"	EA	13					2	6					3		5	29	
*	PAINTED PAVEMENT MARKINGS, STD, WHITE, MESSAGE	EA	2														2	
*	PAINTED PAVEMENT MARKINGS, STD, YELLOW, SOLID 6"	GM	0.255		0.265			0.265	0.226		0.265			0.265		0.227	1.768	
*	PAINTED PAVEMENT MARKINGS, STD, YELLOW, SOLID, 18" FOR DIAGONALS AND CHEVRONS	LF						31			32			32		32	127	
*	PAINTED PAVEMENT MARKINGS, STD, YELLOW, 2-4 DOTTED GUIDELINE/6-10 DOTTED EXTENSION, 6"	GM							0.057							0.038	0.095	
711-11-123	THERMOPLASTIC, STD, WHITE, SOLID, 12" FOR CROSSWALK AND ROUNDABOUT	LF																
711-11-124	THERMOPLASTIC, STD, WHITE, SOLID, 18" FOR DIAGONALS AND CHEVRONS	LF	66														66	
711-11-125	THERMOPLASTIC, STD, WHITE, SOLID, 24" FOR STOP LINE AND CROSSWALK	LF							31								31	
711-11-141	THERMOPLASTIC, STD., WHITE, 2-4 DOTTED GUIDE LINE/ 6-10 DOTTED EXT., 6"	GM	0.014					0.024	0.005		0.019			0.024		0.024	0.110	
711-11-144	THERMOPLASTIC, STANDARD, WHITE, 2-2 DOTTED EXTENSION LINE, 12" FOR ROUNDABOUT	GM	0.003														0.003	
711-11-160	THERMOPLASTIC, STD, WHITE, MESSAGE OR SYMBOL	EA	2														2	
711-11-170	THERMOPLASTIC, STD, WHITE, ARROWS	EA	13					2	6					3		5	29	
711-11-224	THERMOPLASTIC, STD, YELLOW, SOLID, 18" FOR DIAGONAL OR CHEVRON	LF						31			32			32		32	127	
711-11-241	THERMOPLASTIC, STD., YELLOW, 2-4 DOTTED GUIDE LINE/ 6-10 DOTTED EXT., 6"	GM							0.057							0.038	0.095	
711-14-123	THERMOPLASTIC, PREFORMED, WHITE, SOLID, 12" FOR CROSSWALK	LF	120														120	
711-14-125	THERMOPLASTIC, PREFORMED, WHITE, SOLID, 24" FOR CROSSWALK	LF	110														110	
711-15-101	THERMOPLASTIC, STANDARD-OPEN GRADED ASPHALT SURFACES WHITE, SOLID, 6"	GM	0.038		0.265			0.312	0.341		0.266			0.331		0.345	1.898	
711-15-102	THERMOPLASTIC, STANDARD-OPEN GRADED ASPHALT SURFACES, WHITE, SOLID, 8"	GM																
711-15-131	THERMOPLASTIC, STANDARD-OPEN GRADED ASPHALT SURFACES, WHITE, SKIP, 6", 10-30 SKIP OR 3-9 LANE DROP	GM	0.038		0.265			0.265	0.232		0.265			0.265		0.265	1.595	
711-15-201	THERMOPLASTIC, STANDARD-OPEN GRADED ASPHALT SURFACES, YELLOW, SOLID, 6"	GM	0.038		0.265			0.265	0.207		0.265			0.265		0.227	1.532	
711-16-101	THERMOPLASTIC, STANDARD-OTHER SURFACES, WHITE, SOLID, 6"	GM	0.332														0.332	
711-16-102	THERMOPLASTIC, STANDARD-OTHER SURFACES, WHITE, SOLID, 8"	GM	0.047														0.047	
711-16-131	THERMOPLASTIC, STANDARD-OTHER SURFACES, WHITE, SKIP, 6", 10-30 SKIP OR 3-9 LANE DROP	GM	0.093														0.093	
711-16-133	THERMOPLASTIC, STANDARD-OTHER SURFACES WHITE, SKIP, 12"- APPROACH TO TOLL PLAZA OR 3-9 LANE DROP	GM																
711-16-201	THERMOPLASTIC, STANDARD-OTHER SURFACES, YELLOW, SOLID, 6"	GM	0.217						0.019								0.236	

REVISIONS				JAMES E. BRADFORD, P.E. P.E. LICENSE NUMBER 68276 DEWBERRY ENGINEERS INC. 800 NORTH MAGNOLIA AVENUE, STE. 1000 ORLANDO, FL 32803	POLK COUNTY PUBLIC WORKS DEPARTMENT			TABULATION OF QUANTITIES	SHEET NO. S-6
DATE	DESCRIPTION	DATE	DESCRIPTION		ROAD NO.	COUNTY	FINANCIAL PROJECT ID		
					557	POLK	18-73		

THE OFFICIAL RECORD OF THIS SHEET IS THE ELECTRONIC FILE DIGITALLY SIGNED AND SEALED UNDER RULE 61G15-23.004, F.A.C.

TABULATION OF QUANTITIES

PAY ITEM NO.	DESCRIPTION	UNIT	SHEET NUMBERS														TOTAL THIS SHEET	
			S-46		S-47		S-48		S-49		S-50		S-51		S-52		PLAN	FINAL
			PLAN	FINAL	PLAN	FINAL	PLAN	FINAL	PLAN	FINAL	PLAN	FINAL	PLAN	FINAL	PLAN	FINAL		
630-2-11	CONDUIT, F&I, OPEN TRENCH	LF					280										280	
635-2-11	PULL & SPLICE BOX, F&I, 13" x 24" COVER SIZE	EA					12										12	
654-2-21	RECTANGULAR RAPID FLASHING BEACON, F&I - SOLAR POWERED, COMPLETE SIGN ASSEMBLY - SINGLE DIRECTION	AS					12										12	
700-1-11	SINGLE POST SIGN, F&I GROUND MOUNT, UP TO 12 SF	AS					10				4						14	
700-1-12	SINGLE POST SIGN, F&I GROUND MOUNT, 12-20 SF	AS	3		4		3		4		4						18	
700-1-13	SINGLE POST SIGN, F&I GROUND MOUNT, 21-30 SF	AS									1						1	
700-1-50	SINGLE POST SIGN, RELOCATE	AS																
700-1-60	SINGLE POST SIGN, REMOVE	AS			1		8		4		4				2		19	
700-2-12	MULTI-POST SIGN, F&I GROUND MOUNT, 12-20 SF	AS																
700-2-15	MULTI-POST SIGN, F&I GROUND MOUNT, 51-100SF	AS			1				1								2	
700-12-21	SIGN BEACON, F&I GROUND MOUNT- SOLAR POWERED, ONE BEACON	AS	2								2						4	
701-1-101	PROFILED THERMOPLASTIC, STANDARD, WHITE, SOLID, 6"	GM	0.265		0.152												0.417	
701-1-201	PROFILED THERMOPLASTIC, STANDARD, YELLOW, SOLID, 6"	GM	0.265		0.152												0.417	
705-11-1	DELINEATOR, FLEXIBLE TUBULAR	EA									2				2		4	
706-1-3	RAISED PAVEMENT MARKER, TYPE B	EA																
	WHITE/RED		34		42		68		57		72		60		78		411	
	YELLOW/YELLOW										88				60		148	
710-12-290	PAINTED PAVEMENT MARKINGS, DURABLE PAINT, YELLOW, ISLAND NOSE	SF												14.3			14.3	
710-90	PAINTED PAVEMENT MARKINGS, FINAL SURFACE	LS																
*	PAINTED PAVEMENT MARKINGS, STD, WHITE, SOLID, 6"	GM	0.265		0.310		0.458		0.382		0.457		0.359		0.346		2.577	
*	PAINTED PAVEMENT MARKINGS, STD, WHITE, SOLID FOR INTERCHANGE AND URBAN ISLAND, 8"	GM					0.100							0.061			0.161	
*	PAINTED PAVEMENT MARKINGS, STD, WHITE, SOLID FOR CROSSWALK AND ROUNDABOUT, 12"	LF					300				164						464	
*	PAINTED PAVEMENT MARKINGS, STD, WHITE, SOLID FOR DIAGONAL OR CHEVRON, 18"	LF					109					32		53			194	
*	PAINTED PAVEMENT MARKINGS, STD, WHITE, SOLID FOR STOPLINE OR CROSSWALK, 24"	LF					280				180						460	
*	PAINTED PAVEMENT MARKINGS, STD, WHITE, SKIP, 10-30 OR 3-9 SKIP, 6" WIDE	GM	0.265		0.220		0.043		0.190		0.228		0.265		0.265		1.476	
*	PAINTED PAVEMENT MARKING, STD, WHITE, 3'-9" SKIP DROP LINE AND APPROACH TO TOLL PLAZA, 12" WIDE,	GM																
*	PAINTED PAVEMENT MARKINGS, STD, WHITE, 2-4 DOTTED GUIDELINE / 6-10 DOTTED EXT., 6"	GM					0.042		0.016				0.048				0.106	
*	PAINTED PAVEMENT MARKINGS, STD, WHITE, 2-2 DOTTED EXTENSION FOR ROUNDABOUT, 12"	GM					0.027										0.027	
*	PAINTED PAVEMENT MARKINGS, STD, WHITE, ARROW	EA			7		17		13		15		7		8		67	
*	PAINTED PAVEMENT MARKINGS, STD, WHITE, MESSAGE	EA			1		6										7	
*	PAINTED PAVEMENT MARKINGS, STD, YELLOW, SOLID 6"	GM	0.265		0.265		0.294		0.265		0.245		0.266		0.221		1.821	
*	PAINTED PAVEMENT MARKINGS, STD, YELLOW, SOLID, 18" FOR DIAGONALS AND CHEVRONS	LF							33				63				96	
*	PAINTED PAVEMENT MARKINGS, STD, YELLOW, 2-4 DOTTED GUIDELINE/6-10 DOTTED EXTENSION, 6"	GM									0.073				0.044		0.117	
711-11-123	THERMOPLASTIC, STD, WHITE, SOLID, 12" FOR CROSSWALK AND ROUNDABOUT	LF																
711-11-124	THERMOPLASTIC, STD, WHITE, SOLID, 18" FOR DIAGONALS AND CHEVRONS	LF					109					32		53			194	
711-11-125	THERMOPLASTIC, STD, WHITE, SOLID, 24" FOR STOP LINE AND CROSSWALK	LF									24						24	
711-11-141	THERMOPLASTIC, STD., WHITE, 2-4 DOTTED GUIDE LINE/ 6-10 DOTTED EXT., 6"	GM					0.042		0.016				0.048				0.106	
711-11-144	THERMOPLASTIC, STANDARD, WHITE, 2-2 DOTTED EXTENSION LINE, 12" FOR ROUNDABOUT	GM					0.027										0.027	
711-11-160	THERMOPLASTIC, STD, WHITE, MESSAGE OR SYMBOL	EA			1		6										7	
711-11-170	THERMOPLASTIC, STD, WHITE, ARROWS	EA			7		17		13		15		7		8		67	
711-11-224	THERMOPLASTIC, STD, YELLOW, SOLID, 18" FOR DIAGONAL OR CHEVRON	LF							33				63				96	
711-11-241	THERMOPLASTIC, STD., YELLOW, 2-4 DOTTED GUIDE LINE/ 6-10 DOTTED EXT., 6"	GM									0.073				0.044		0.117	
711-14-123	THERMOPLASTIC, PREFORMED, WHITE, SOLID, 12" FOR CROSSWALK	LF					300				164						464	
711-14-125	THERMOPLASTIC, PREFORMED, WHITE, SOLID, 24" FOR CROSSWALK	LF					280				156						436	
711-15-101	THERMOPLASTIC, STANDARD-OPEN GRADED ASPHALT SURFACES WHITE, SOLID, 6"	GM	0.265		0.152				0.154		0.367		0.359		0.346		1.643	
711-15-102	THERMOPLASTIC, STANDARD-OPEN GRADED ASPHALT SURFACES, WHITE, SOLID, 8"	GM												0.061			0.061	
711-15-131	THERMOPLASTIC, STANDARD-OPEN GRADED ASPHALT SURFACES, WHITE, SKIP, 6", 10-30 SKIP OR 3-9 LANE DROP	GM	0.265		0.152				0.114		0.228		0.265		0.265		1.289	
711-15-201	THERMOPLASTIC, STANDARD-OPEN GRADED ASPHALT SURFACES, YELLOW, SOLID, 6"	GM	0.265		0.152				0.114		0.192		0.266		0.221		1.210	
711-16-101	THERMOPLASTIC, STANDARD-OTHER SURFACES, WHITE, SOLID, 6"	GM			0.158		0.458		0.228		0.090						0.934	
711-16-102	THERMOPLASTIC, STANDARD-OTHER SURFACES, WHITE, SOLID, 8"	GM					0.100										0.100	
711-16-131	THERMOPLASTIC, STANDARD-OTHER SURFACES, WHITE, SKIP, 6", 10-30 SKIP OR 3-9 LANE DROP	GM			0.068		0.043		0.076								0.187	
711-16-133	THERMOPLASTIC, STANDARD-OTHER SURFACES WHITE, SKIP, 12"- APPROACH TO TOLL PLAZA OR 3-9 LANE DROP	GM																
711-16-201	THERMOPLASTIC, STANDARD-OTHER SURFACES, YELLOW, SOLID, 6"	GM			0.113		0.294		0.151		0.053						0.611	

REVISIONS				JAMES E. BRADFORD, P.E. P.E. LICENSE NUMBER 68276 DEWBERRY ENGINEERS INC. 800 NORTH MAGNOLIA AVENUE, STE. 1000 ORLANDO, FL 32803	POLK COUNTY PUBLIC WORKS DEPARTMENT			<b>TABULATION OF QUANTITIES</b>	SHEET NO.
DATE	DESCRIPTION	DATE	DESCRIPTION		ROAD NO.	COUNTY	FINANCIAL PROJECT ID		
					557	POLK	18-73		S-7

THE OFFICIAL RECORD OF THIS SHEET IS THE ELECTRONIC FILE DIGITALLY SIGNED AND SEALED UNDER RULE 61G15-23.004, F.A.C.

TABULATION OF QUANTITIES

PAY ITEM NO.	DESCRIPTION	UNIT	SHEET NUMBERS														TOTAL THIS SHEET	
			S-53		S-54		S-55		S-56		S-57		S-58		S-59		PLAN	FINAL
			PLAN	FINAL	PLAN	FINAL	PLAN	FINAL	PLAN	FINAL	PLAN	FINAL	PLAN	FINAL	PLAN	FINAL		
630-2-11	CONDUIT, F&I, OPEN TRENCH	LF																
635-2-11	PULL & SPLICE BOX, F&I, 13" x 24" COVER SIZE	EA																
654-2-21	RECTANGULAR RAPID FLASHING BEACON, F&I - SOLAR POWERED, COMPLETE SIGN ASSEMBLY - SINGLE DIRECTION	AS																
700-1-11	SINGLE POST SIGN, F&I GROUND MOUNT, UP TO 12 SF	AS									1		3				4	
700-1-12	SINGLE POST SIGN, F&I GROUND MOUNT, 12-20 SF	AS	2														2	
700-1-13	SINGLE POST SIGN, F&I GROUND MOUNT, 21-30 SF	AS																
700-1-50	SINGLE POST SIGN, RELOCATE	AS																
700-1-60	SINGLE POST SIGN, REMOVE	AS	3		4				1				1				9	
700-2-12	MULTI-POST SIGN, F&I GROUND MOUNT, 12-20 SF	AS																
700-2-15	MULTI-POST SIGN, F&I GROUND MOUNT, 51-100SF	AS																
700-12-21	SIGN BEACON, F&I GROUND MOUNT- SOLAR POWERED, ONE BEACON	AS																
701-1-101	PROFILED THERMOPLASTIC, STANDARD, WHITE, SOLID, 6"	GM																
701-1-201	PROFILED THERMOPLASTIC, STANDARD, YELLOW, SOLID, 6"	GM																
705-11-1	DELINEATOR, FLEXIBLE TUBULAR	EA																
706-1-3	RAISED PAVEMENT MARKER, TYPE B	EA																
	WHITE/RED		42		34			21		6			13				116	
	YELLOW/YELLOW												24		24		48	
710-12-290	PAINTED PAVEMENT MARKINGS, DURABLE PAINT, YELLOW, ISLAND NOSE	SF																
710-90	PAINTED PAVEMENT MARKINGS, FINAL SURFACE	LS																
*	PAINTED PAVEMENT MARKINGS, STD, WHITE, SOLID, 6"	GM	0.249		0.265			0.150		0.046		0.121		0.167		0.179		1.177
*	PAINTED PAVEMENT MARKINGS, STD, WHITE, SOLID FOR INTERCHANGE AND URBAN ISLAND, 8"	GM	0.016									0.047						0.063
*	PAINTED PAVEMENT MARKINGS, STD, WHITE, SOLID FOR CROSSWALK AND ROUNDABOUT, 12"	LF																
*	PAINTED PAVEMENT MARKINGS, STD, WHITE, SOLID FOR DIAGONAL OR CHEVRON, 18"	LF	4															4
*	PAINTED PAVEMENT MARKINGS, STD, WHITE, SOLID FOR STOPLINE OR CROSSWALK, 24"	LF																
*	PAINTED PAVEMENT MARKINGS, STD, WHITE, SKIP, 10-30 OR 3-9 SKIP, 6" WIDE	GM	0.265		0.265			0.147		0.046								0.723
*	PAINTED PAVEMENT MARKING, STD, WHITE, 3'-9" SKIP DROP LINE AND APPROACH TO TOLL PLAZA, 12" WIDE,	GM																
*	PAINTED PAVEMENT MARKINGS, STD, WHITE, 2-4 DOTTED GUIDELINE / 6-10 DOTTED EXT., 6"	GM	0.016									0.013						0.029
*	PAINTED PAVEMENT MARKINGS, STD, WHITE, 2-2 DOTTED EXTENSION FOR ROUNDABOUT, 12"	GM																
*	PAINTED PAVEMENT MARKINGS, STD, WHITE, ARROW	EA	1									6						7
*	PAINTED PAVEMENT MARKINGS, STD, WHITE, MESSAGE	EA										4						4
*	PAINTED PAVEMENT MARKINGS, STD, YELLOW, SOLID 6"	GM	0.265		0.265			0.119		0.046		0.139		0.174		0.179		1.187
*	PAINTED PAVEMENT MARKINGS, STD, YELLOW, SOLID, 18" FOR DIAGONALS AND CHEVRONS	LF										8						8
*	PAINTED PAVEMENT MARKINGS, STD, YELLOW, 2-4 DOTTED GUIDELINE/6-10 DOTTED EXTENSION, 6"	GM																
711-11-123	THERMOPLASTIC, STD, WHITE, SOLID, 12" FOR CROSSWALK AND ROUNDABOUT	LF																
711-11-124	THERMOPLASTIC, STD, WHITE, SOLID, 18" FOR DIAGONALS AND CHEVRONS	LF	4															4
711-11-125	THERMOPLASTIC, STD, WHITE, SOLID, 24" FOR STOP LINE AND CROSSWALK	LF																
711-11-141	THERMOPLASTIC, STD., WHITE, 2-4 DOTTED GUIDE LINE/ 6-10 DOTTED EXT., 6"	GM	0.016									0.013						0.029
711-11-144	THERMOPLASTIC, STANDARD, WHITE, 2-2 DOTTED EXTENSION LINE, 12" FOR ROUNDABOUT	GM																
711-11-160	THERMOPLASTIC, STD, WHITE, MESSAGE OR SYMBOL	EA										4						4
711-11-170	THERMOPLASTIC, STD, WHITE, ARROWS	EA	1									6						7
711-11-224	THERMOPLASTIC, STD, YELLOW, SOLID, 18" FOR DIAGONAL OR CHEVRON	LF										8						8
711-11-241	THERMOPLASTIC, STD., YELLOW, 2-4 DOTTED GUIDE LINE/ 6-10 DOTTED EXT., 6"	GM																
711-14-123	THERMOPLASTIC, PREFORMED, WHITE, SOLID, 12" FOR CROSSWALK	LF																
711-14-125	THERMOPLASTIC, PREFORMED, WHITE, SOLID, 24" FOR CROSSWALK	LF																
711-15-101	THERMOPLASTIC, STANDARD-OPEN GRADED ASPHALT SURFACES WHITE, SOLID, 6"	GM	0.249		0.208													0.457
711-15-102	THERMOPLASTIC, STANDARD-OPEN GRADED ASPHALT SURFACES, WHITE, SOLID, 8"	GM	0.016															0.016
711-15-131	THERMOPLASTIC, STANDARD-OPEN GRADED ASPHALT SURFACES, WHITE, SKIP, 6", 10-30 SKIP OR 3-9 LANE DROP	GM	0.265		0.208													0.473
711-15-201	THERMOPLASTIC, STANDARD-OPEN GRADED ASPHALT SURFACES, YELLOW, SOLID, 6"	GM	0.265		0.208													0.473
711-16-101	THERMOPLASTIC, STANDARD-OTHER SURFACES, WHITE, SOLID, 6"	GM			0.057			0.150		0.046		0.121		0.167		0.179		0.720
711-16-102	THERMOPLASTIC, STANDARD-OTHER SURFACES, WHITE, SOLID, 8"	GM										0.047						0.047
711-16-131	THERMOPLASTIC, STANDARD-OTHER SURFACES, WHITE, SKIP, 6", 10-30 SKIP OR 3-9 LANE DROP	GM			0.057			0.147		0.046								0.250
711-16-133	THERMOPLASTIC, STANDARD-OTHER SURFACES WHITE, SKIP, 12"- APPROACH TO TOLL PLAZA OR 3-9 LANE DROP	GM																
711-16-201	THERMOPLASTIC, STANDARD-OTHER SURFACES, YELLOW, SOLID, 6"	GM			0.057			0.119		0.046		0.139		0.174		0.179		0.714

REVISIONS				JAMES E. BRADFORD, P.E. P.E. LICENSE NUMBER 68276 DEWBERRY ENGINEERS INC. 800 NORTH MAGNOLIA AVENUE, STE. 1000 ORLANDO, FL 32803	POLK COUNTY PUBLIC WORKS DEPARTMENT			TABULATION OF QUANTITIES	SHEET NO.
DATE	DESCRIPTION	DATE	DESCRIPTION		ROAD NO.	COUNTY	FINANCIAL PROJECT ID		
					557	POLK	18-73		S-8

THE OFFICIAL RECORD OF THIS SHEET IS THE ELECTRONIC FILE DIGITALLY SIGNED AND SEALED UNDER RULE 61G15-23.004, F.A.C.



**TABULATION OF QUANTITIES**

PAY ITEM NO.	DESCRIPTION	UNIT	SHEET NUMBERS										TOTAL THIS SHEET		GRAND TOTAL			
			S-60		S-61		S-62		S-63		PLAN	FINAL	PLAN	FINAL				
			PLAN	FINAL	PLAN	FINAL	PLAN	FINAL	PLAN	FINAL								
630-2-11	CONDUIT, F&I, OPEN TRENCH	LF															595	
635-2-11	PULL & SPLICE BOX, F&I, 13" x 24" COVER SIZE	EA															24	
654-2-21	RECTANGULAR RAPID FLASHING BEACON, F&I - SOLAR POWERED, COMPLETE SIGN ASSEMBLY - SINGLE DIRECTION	AS															24	
700-1-11	SINGLE POST SIGN, F&I GROUND MOUNT, UP TO 12 SF	AS							1					1			86	
700-1-12	SINGLE POST SIGN, F&I GROUND MOUNT, 12-20 SF	AS															54	
700-1-13	SINGLE POST SIGN, F&I GROUND MOUNT, 21-30 SF	AS															12	
700-1-50	SINGLE POST SIGN, RELOCATE	AS															2	
700-1-60	SINGLE POST SIGN, REMOVE	AS															92	
700-2-12	MULTI-POST SIGN, F&I GROUND MOUNT, 12-20 SF	AS															2	
700-2-15	MULTI-POST SIGN, F&I GROUND MOUNT, 51-100SF	AS			1		1							2			6	
700-12-21	SIGN BEACON, F&I GROUND MOUNT- SOLAR POWERED, ONE BEACON	AS															8	
701-1-101	PROFILED THERMOPLASTIC, STANDARD, WHITE, SOLID, 6"	GM															2.022	
701-1-201	PROFILED THERMOPLASTIC, STANDARD, YELLOW, SOLID, 6"	GM															1.566	
705-11-1	DELINEATOR, FLEXIBLE TUBULAR	EA															36	
706-1-3	RAISED PAVEMENT MARKER, TYPE B	EA																
	WHITE/RED																2143	
	YELLOW/YELLOW		36		74		16		68					194			1073	
710-12-290	PAINTED PAVEMENT MARKINGS, DURABLE PAINT, YELLOW, ISLAND NOSE	SF															248.4	
710-90	PAINTED PAVEMENT MARKINGS, FINAL SURFACE	LS																
*	PAINTED PAVEMENT MARKINGS, STD, WHITE, SOLID, 6"	GM	0.259		0.286		0.070		0.091					0.706			15.035	
*	PAINTED PAVEMENT MARKINGS, STD, WHITE, SOLID FOR INTERCHANGE AND URBAN ISLAND, 8"	GM															0.518	
*	PAINTED PAVEMENT MARKINGS, STD, WHITE, SOLID FOR CROSSWALK AND ROUNDABOUT, 12"	LF															2308	
*	PAINTED PAVEMENT MARKINGS, STD, WHITE, SOLID FOR DIAGONAL OR CHEVRON, 18"	LF															415	
*	PAINTED PAVEMENT MARKINGS, STD, WHITE, SOLID FOR STOPLINE OR CROSSWALK, 24"	LF															1929	
*	PAINTED PAVEMENT MARKINGS, STD, WHITE, SKIP, 10-30 OR 3-9 SKIP, 6" WIDE	GM															10.116	
*	PAINTED PAVEMENT MARKING, STD, WHITE, 3'-9" SKIP DROP LINE AND APPROACH TO TOLL PLAZA, 12" WIDE,	GM															0.100	
*	PAINTED PAVEMENT MARKINGS, STD, WHITE, 2-4 DOTTED GUIDELINE / 6-10 DOTTED EXT., 6"	GM															0.717	
*	PAINTED PAVEMENT MARKINGS, STD, WHITE, 2-2 DOTTED EXTENSION FOR ROUNDABOUT, 12"	GM															0.052	
*	PAINTED PAVEMENT MARKINGS, STD, WHITE, ARROW	EA															212	
*	PAINTED PAVEMENT MARKINGS, STD, WHITE, MESSAGE	EA															23	
*	PAINTED PAVEMENT MARKINGS, STD, YELLOW, SOLID 6"	GM	0.258		0.331		0.084		0.170					0.843			12.790	
*	PAINTED PAVEMENT MARKINGS, STD, YELLOW, SOLID, 18" FOR DIAGONALS AND CHEVRONS	LF			82		10		121					213			797	
*	PAINTED PAVEMENT MARKINGS, STD, YELLOW, 2-4 DOTTED GUIDELINE/6-10 DOTTED EXTENSION, 6"	GM															0.631	
711-11-123	THERMOPLASTIC, STD, WHITE, SOLID, 12" FOR CROSSWALK AND ROUNDABOUT	LF															584	
711-11-124	THERMOPLASTIC, STD, WHITE, SOLID, 18" FOR DIAGONALS AND CHEVRONS	LF															415	
711-11-125	THERMOPLASTIC, STD, WHITE, SOLID, 24" FOR STOP LINE AND CROSSWALK	LF															372	
711-11-141	THERMOPLASTIC, STD., WHITE, 2-4 DOTTED GUIDE LINE/ 6-10 DOTTED EXT., 6"	GM															0.717	
711-11-144	THERMOPLASTIC, STANDARD, WHITE, 2-2 DOTTED EXTENSION LINE, 12" FOR ROUNDABOUT	GM															0.052	
711-11-160	THERMOPLASTIC, STD, WHITE, MESSAGE OR SYMBOL	EA															23	
711-11-170	THERMOPLASTIC, STD, WHITE, ARROWS	EA															212	
711-11-224	THERMOPLASTIC, STD, YELLOW, SOLID, 18" FOR DIAGONAL OR CHEVRON	LF			82		10		121					213			797	
711-11-241	THERMOPLASTIC, STD., YELLOW, 2-4 DOTTED GUIDE LINE/ 6-10 DOTTED EXT., 6"	GM															0.605	
711-14-123	THERMOPLASTIC, PREFORMED, WHITE, SOLID, 12" FOR CROSSWALK	LF															1724	
711-14-125	THERMOPLASTIC, PREFORMED, WHITE, SOLID, 24" FOR CROSSWALK	LF															1557	
711-15-101	THERMOPLASTIC, STANDARD-OPEN GRADED ASPHALT SURFACES WHITE, SOLID, 6"	GM															3.998	
711-15-102	THERMOPLASTIC, STANDARD-OPEN GRADED ASPHALT SURFACES, WHITE, SOLID, 8"	GM															0.077	
711-15-131	THERMOPLASTIC, STANDARD-OPEN GRADED ASPHALT SURFACES, WHITE, SKIP, 6", 10-30 SKIP OR 3-9 LANE DROP	GM															3.357	
711-15-201	THERMOPLASTIC, STANDARD-OPEN GRADED ASPHALT SURFACES, YELLOW, SOLID, 6"	GM															3.215	
711-16-101	THERMOPLASTIC, STANDARD-OTHER SURFACES, WHITE, SOLID, 6"	GM	0.259		0.286		0.070		0.091					0.706			11.037	
711-16-102	THERMOPLASTIC, STANDARD-OTHER SURFACES, WHITE, SOLID, 8"	GM															0.441	
711-16-131	THERMOPLASTIC, STANDARD-OTHER SURFACES, WHITE, SKIP, 6", 10-30 SKIP OR 3-9 LANE DROP	GM															6.759	
711-16-133	THERMOPLASTIC, STANDARD-OTHER SURFACES WHITE, SKIP, 12"- APPROACH TO TOLL PLAZA OR 3-9 LANE DROP	GM															0.100	
711-16-201	THERMOPLASTIC, STANDARD-OTHER SURFACES, YELLOW, SOLID, 6"	GM	0.258		0.331		0.084		0.170					0.843			9.575	

<table border="1"> <thead> <tr> <th colspan="4">REVISIONS</th> </tr> <tr> <th>DATE</th> <th>DESCRIPTION</th> <th>DATE</th> <th>DESCRIPTION</th> </tr> </thead> <tbody> <tr> <td> </td> <td> </td> <td> </td> <td> </td> </tr> </tbody> </table>				REVISIONS				DATE	DESCRIPTION	DATE	DESCRIPTION					JAMES E. BRADFORD, P.E. P.E. LICENSE NUMBER 68276 DEWBERRY ENGINEERS INC. 800 NORTH MAGNOLIA AVENUE, STE. 1000 ORLANDO, FL 32803	POLK COUNTY PUBLIC WORKS DEPARTMENT <table border="1"> <thead> <tr> <th>ROAD NO.</th> <th>COUNTY</th> <th>FINANCIAL PROJECT ID</th> </tr> </thead> <tbody> <tr> <td>557</td> <td>POLK</td> <td>18-73</td> </tr> </tbody> </table>	ROAD NO.	COUNTY	FINANCIAL PROJECT ID	557	POLK	18-73	SHEET NO. S-9
REVISIONS																								
DATE	DESCRIPTION	DATE	DESCRIPTION																					
ROAD NO.	COUNTY	FINANCIAL PROJECT ID																						
557	POLK	18-73																						

THE OFFICIAL RECORD OF THIS SHEET IS THE ELECTRONIC FILE DIGITALLY SIGNED AND SEALED UNDER RULE 61G15-23.004, F.A.C.

**GENERAL NOTES**

1. IT SHOULD BE NOTED THAT EXISTING SIGNAGE REFLECTS INVENTORY DATA COLLECTED DURING PLANS PREPARATION AND IT IS POSSIBLE THAT ADDITIONAL SIGNS MAY BE PRESENT AT THE TIME OF CONSTRUCTION. COORDINATE THE DISPOSITION OF SUCH SIGNS WITH THE ENGINEER-OF-RECORD.
2. REFLECTIVE PAVEMENT MARKERS ARE NOT TO BE PLACED ON SIDE STREET CENTERLINES, UNLESS OTHERWISE NOTED ON THE PLANS.
3. ALL SIGN PANELS TO BE FABRICATED UTILIZING ASTM TYPE XI REFLECTIVE SHEETING.

**STREET NAME SIGN PANEL DETAILS**

**EXAMPLE STREET NAME SIGN**



FABRICATE PANELS WITH THE FOLLOWING STREET NAMES:

CR 557  
E PARK LN  
W PARK LN  
CREEK RD  
GUM RD

**GENERAL NOTES:**

TEXT SHALL BE MIXED UPPER/LOWER CASE

GREEN BACKGROUND WITH 0.5" WHITE BORDER AND WHITE LEGEND

ALL OTHER DETAILS TO BE PER THE STANDARD HIGHWAY SIGNS

SHOP DRAWINGS ARE REQUIRED PRIOR TO FABRICATION

**EXAMPLE STREET NAME SIGN (REDUCED LETTER HEIGHT)**

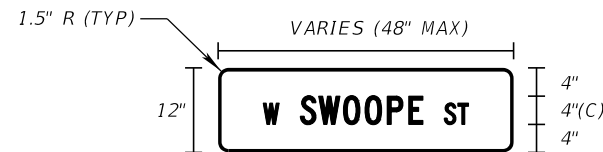

FABRICATE PANELS WITH THE FOLLOWING STREET NAMES:

W SWOOPE ST  
ACCESS RD  
WAYLANCO RD  
WGTO TOWER RD

**EXAMPLE STREET NAME SIGN (REDUCED LETTER HEIGHT & FONT)**

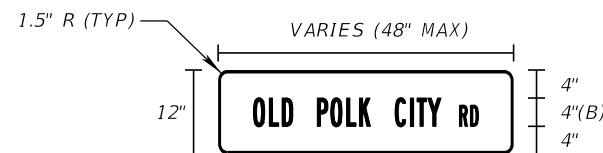

FABRICATE PANELS WITH THE FOLLOWING STREET NAMES:

W INTERLACHEN ST  
OLD POLK CITY RD  
OLD LAKE ALFRED RD

**PAY ITEM NOTES**

700-12-21: PAY ITEM INCLUDES THE COST OF CABINET, CONTROLLER, AND SOLAR PANEL.

**MULTI-POST SIGN DATA**

HORIZONTAL CLEARANCE (A) (ft)	STATION	SIGN NAME	SIGN NO.	SIGN SIZE (W X H) (ft)	SIDE SLOPE (RISE:RUN)	CLEAR HEIGHT (ft)	NO. OF POSTS	AVERAGE LENGTH OF POSTS (ft)	STEEL POSTS	HORIZONTAL CLEARANCE NOTES
16'-0"	1368+30	GM-1	101	8'-6" X 9'-0"	1:4	8'-4"	2	17.59	W8x18	FROM EDGE OF TRAVEL
12'-0"	1386+20	GM-2	102	8'-6" X 9'-0"	1:4	9'-2"	2	18.42	W8x18	FROM EDGE OF TRAVEL
3'-0"	613+20	GM-3	103	11'-6" X 5'-6"	1:4	8'-6"	2	14.78	W6x12	FROM FACE OF CURB
12'-0"	703+00	GM-4	104	11'-6" X 5'-6"	1:9	8'-1"	2	13.57	W6x12	FROM EDGE OF TRAVEL
12'-0"	1435+90	GM-5	105	11'-0" X 9'-0"	1:4	9'-6"	2	19.07	W8x18	FROM EDGE OF TRAVEL
12'-0"	1453+90	GM-6	106	11'-0" X 9'-0"	1:4	9'-6"	2	19.07	W8x18	FROM EDGE OF TRAVEL
12'-0"	1233+00	GM-7	107	6'-0" X 2'-6"	1:4	8'-5"	2	11.64	S3x5.7	FROM EDGE OF TRAVEL
20'-0"	1248+80	GM-8	107	6'-0" X 2'-6"	1:3	9'-0"	2	12.48	S3x5.7	FROM EDGE OF TRAVEL

**MULTI-POST SIGN NOTES**

1. FOR ADDITIONAL DETAILS AND NOTES SEE FDOT STANDARD PLANS NOS. 700-020 AND 700-101.
2. CLEAR HEIGHT IS THE DISTANCE BETWEEN THE BOTTOM OF THE MAIN SIGN PANEL AND THE GROUND AT THE CENTER OF THE MAIN SIGN PANEL.

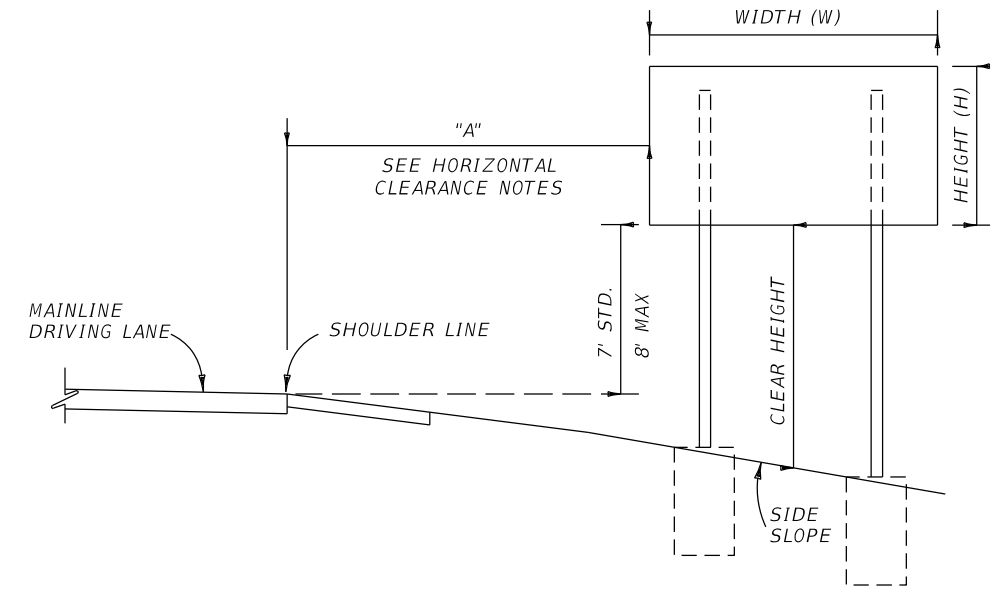

REVISIONS			
DATE	DESCRIPTION	DATE	DESCRIPTION

JAMES E. BRADFORD, P.E.  
P.E. LICENSE NUMBER 68276  
DEWBERRY ENGINEERS INC.  
800 NORTH MAGNOLIA AVENUE, STE. 1000  
ORLANDO, FL 32803

POLK COUNTY PUBLIC WORKS DEPARTMENT		
ROAD NO.	COUNTY	FINANCIAL PROJECT ID
557	POLK	18-73

**GENERAL NOTES  
AND DETAILS**

SHEET NO.  
S-10

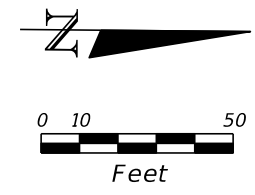

BEGIN PAVEMENT MARKINGS  
MATCH EXISTING  
Q CONST. CR 557  
STA. 1188+00.00

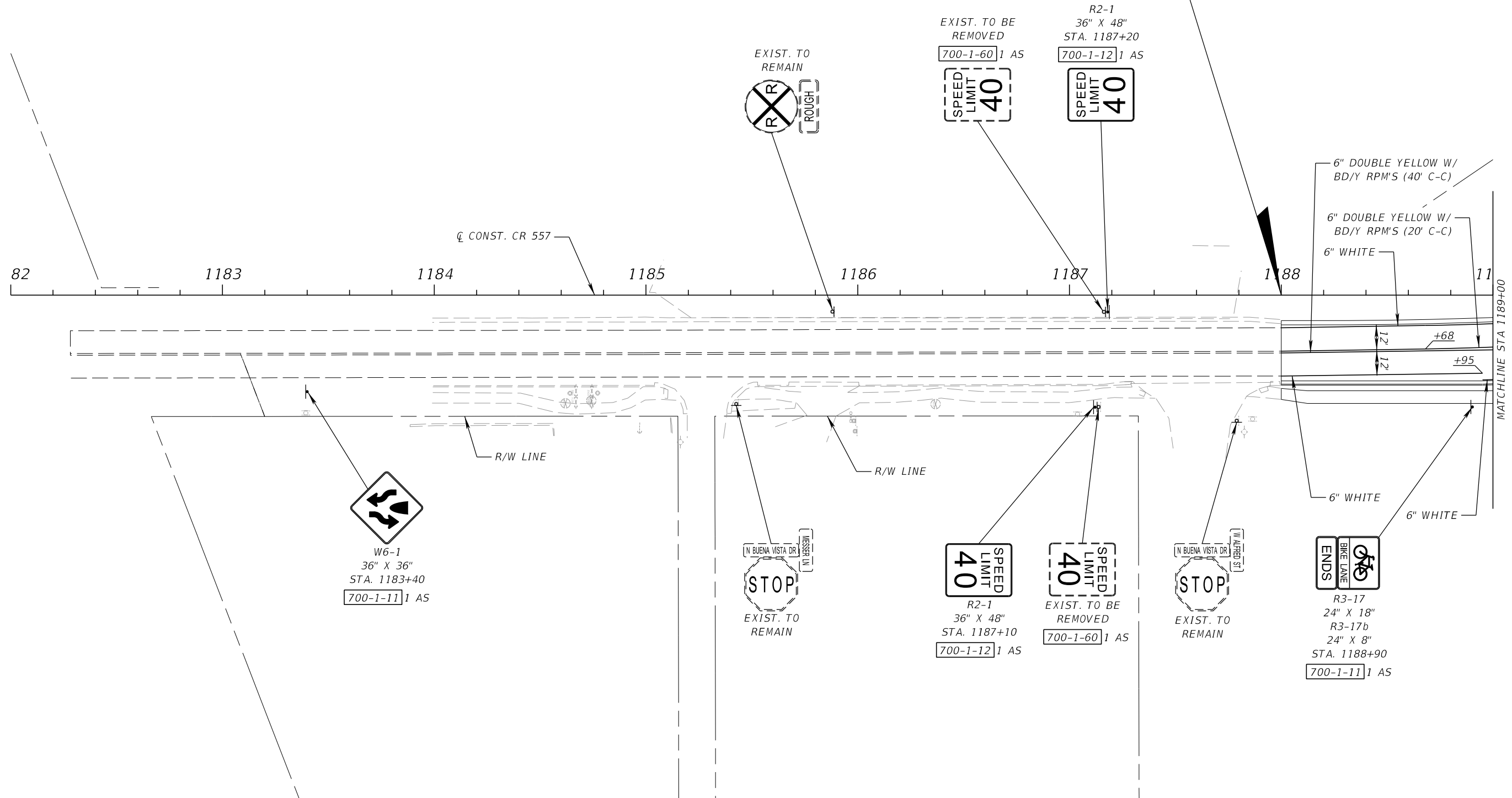

REVISIONS			
DATE	DESCRIPTION	DATE	DESCRIPTION

JAMES E. BRADFORD, P.E.  
P.E. LICENSE NUMBER 68276  
DEWBERRY ENGINEERS INC.  
800 NORTH MAGNOLIA AVENUE, STE. 1000  
ORLANDO, FL 32803

POLK COUNTY PUBLIC WORKS DEPARTMENT		
ROAD NO.	COUNTY	FINANCIAL PROJECT ID
557	POLK	18-73

**SIGNING AND PAVEMENT  
MARKING PLAN**

SHEET  
NO.  
S-11

THE OFFICIAL RECORD OF THIS SHEET IS THE ELECTRONIC FILE DIGITALLY SIGNED AND SEALED UNDER RULE 61G15-23.004, F.A.C.

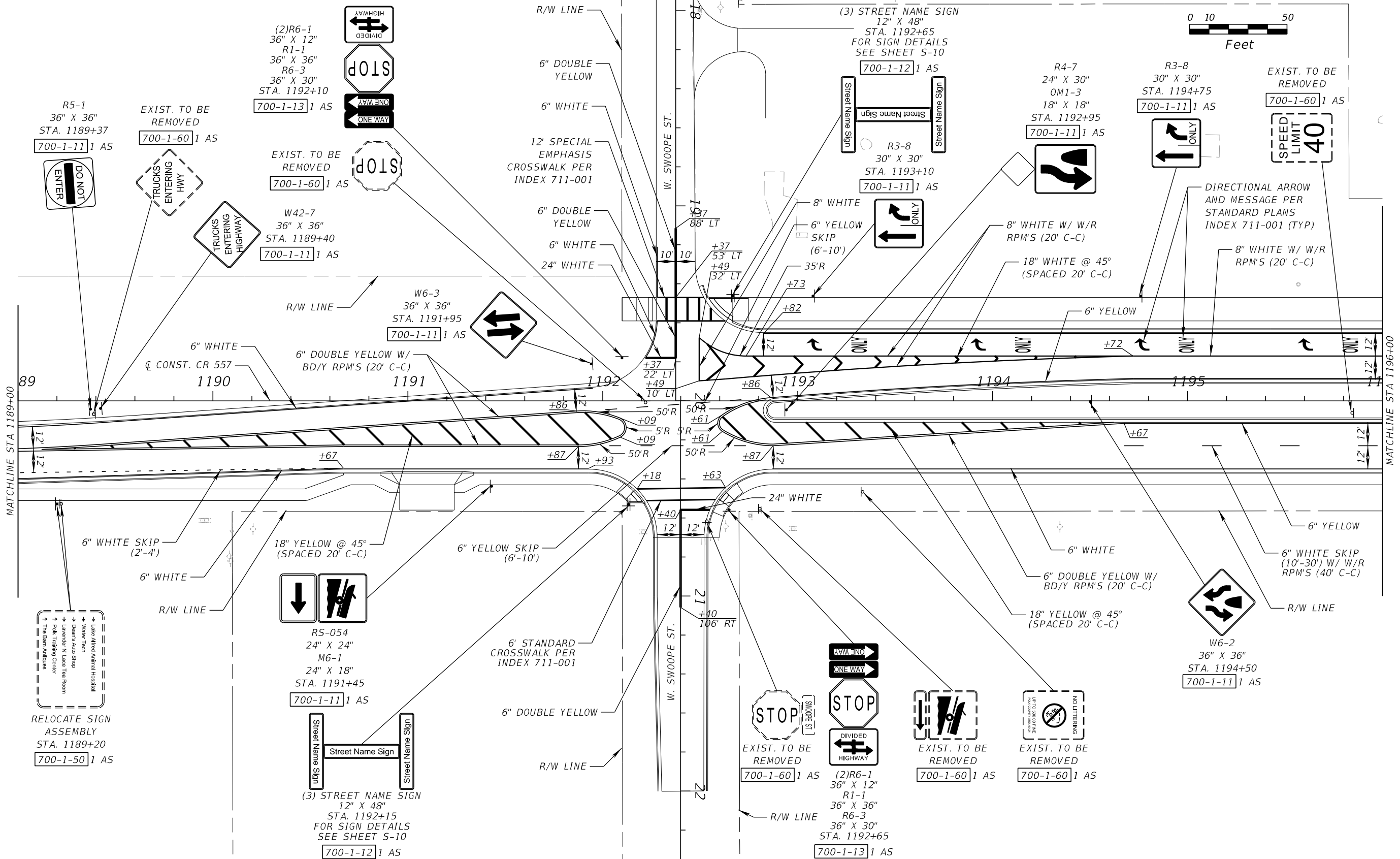
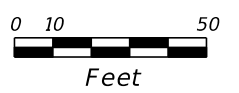

MATCHLINE STA 1189+00

MATCHLINE STA 1196+00

R5-1  
36" X 36"  
STA. 1189+37  
700-1-11 1 AS

EXIST. TO BE REMOVED  
700-1-60 1 AS

(2)R6-1  
36" X 12"  
R1-1  
36" X 36"  
R6-3  
36" X 30"  
STA. 1192+10  
700-1-13 1 AS

EXIST. TO BE REMOVED  
700-1-60 1 AS

W42-7  
36" X 36"  
STA. 1189+40  
700-1-11 1 AS

W6-3  
36" X 36"  
STA. 1191+95  
700-1-11 1 AS

(3) STREET NAME SIGN  
12" X 48"  
STA. 1192+65  
FOR SIGN DETAILS  
SEE SHEET S-10  
700-1-12 1 AS

R4-7  
24" X 30"  
OM1-3  
18" X 18"  
STA. 1192+95  
700-1-11 1 AS

R3-8  
30" X 30"  
STA. 1194+75  
700-1-11 1 AS

EXIST. TO BE REMOVED  
700-1-60 1 AS

RS-054  
24" X 24"  
M6-1  
24" X 18"  
STA. 1191+45  
700-1-11 1 AS

RELOCATE SIGN  
ASSEMBLY  
STA. 1189+20  
700-1-50 1 AS

(3) STREET NAME SIGN  
12" X 48"  
STA. 1192+15  
FOR SIGN DETAILS  
SEE SHEET S-10  
700-1-12 1 AS

EXIST. TO BE REMOVED  
700-1-60 1 AS

(2)R6-1  
36" X 12"  
R1-1  
36" X 36"  
R6-3  
36" X 30"  
STA. 1192+65  
700-1-13 1 AS

EXIST. TO BE REMOVED  
700-1-60 1 AS

EXIST. TO BE REMOVED  
700-1-60 1 AS

W6-2  
36" X 36"  
STA. 1194+50  
700-1-11 1 AS

REVISIONS			
DATE	DESCRIPTION	DATE	DESCRIPTION

JAMES E. BRADFORD, P.E.  
P.E. LICENSE NUMBER 68276  
DEWBERRY ENGINEERS INC.  
800 NORTH MAGNOLIA AVENUE, STE. 1000  
ORLANDO, FL 32803

POLK COUNTY PUBLIC WORKS DEPARTMENT		
ROAD NO.	COUNTY	FINANCIAL PROJECT ID
557	POLK	18-73

**SIGNING AND PAVEMENT  
MARKING PLAN**

SHEET NO.  
S-12

THE OFFICIAL RECORD OF THIS SHEET IS THE ELECTRONIC FILE DIGITALLY SIGNED AND SEALED UNDER RULE 61G15-23.004, F.A.C.

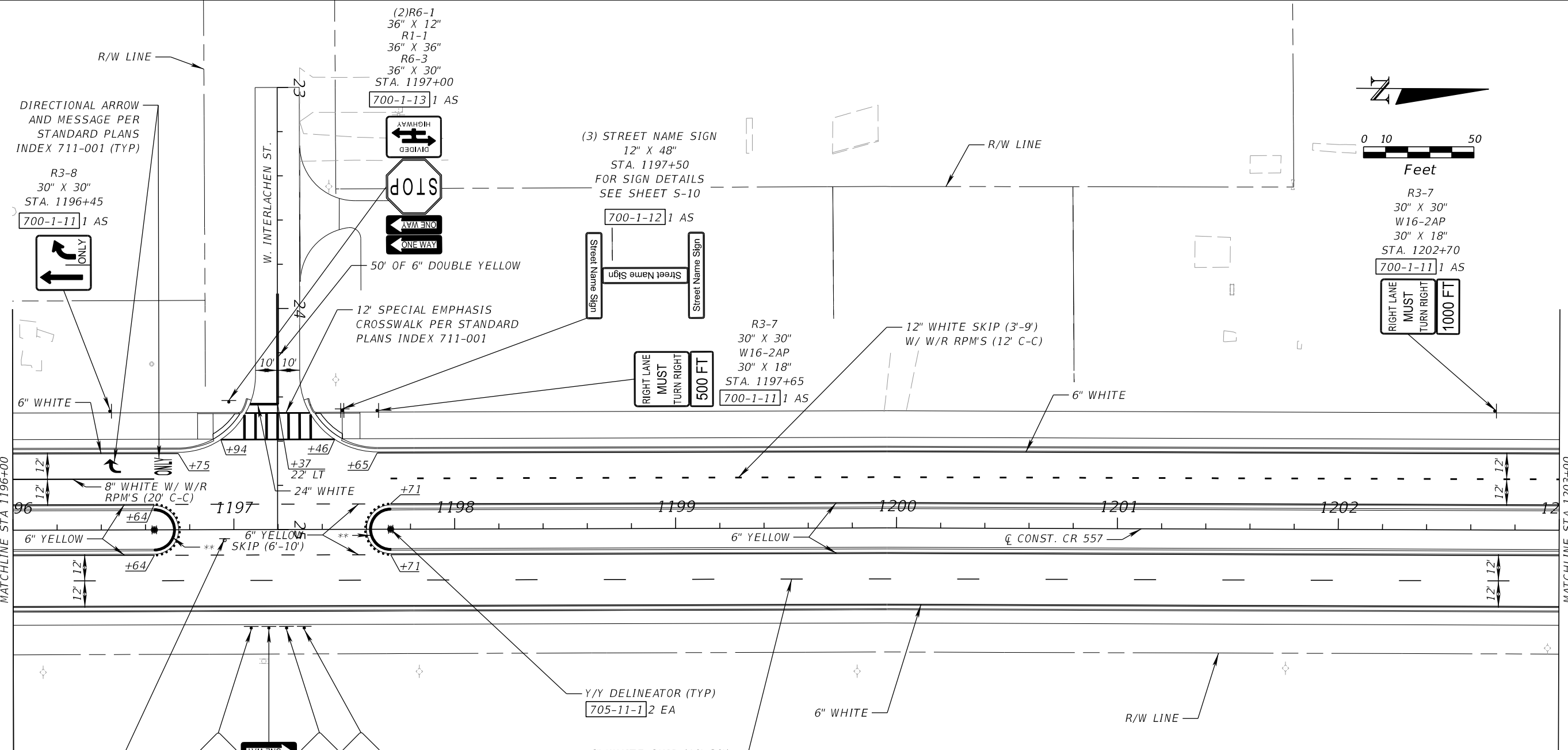
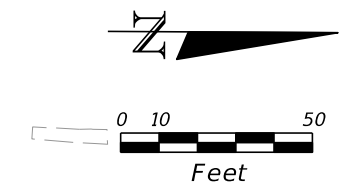

R3-8  
30" X 30"  
STA. 1196+45  
700-1-11 1 AS

(2)R6-1  
36" X 12"  
R1-1  
36" X 36"  
R6-3  
36" X 30"  
STA. 1197+00  
700-1-13 1 AS

(3) STREET NAME SIGN  
12" X 48"  
STA. 1197+50  
FOR SIGN DETAILS  
SEE SHEET S-10

700-1-12 1 AS

R3-7  
30" X 30"  
W16-2AP  
30" X 18"  
STA. 1197+65  
700-1-11 1 AS

R3-7  
30" X 30"  
W16-2AP  
30" X 18"  
STA. 1202+70  
700-1-11 1 AS

(3) OM1-3  
18" X 18"  
R6-1  
54" X 18"  
STA. 1197+15  
700-1-11 4 AS

EXIST. TO BE  
REMOVED  
700-1-60 1 AS

\*\*  
YELLOW ISLAND  
NOSE PAINT W/  
MD/Y RPM'S PER  
INDEX 706-001  
710-12-290 43.0 SF  
706-1-3 70 EA  
TOTAL THIS SHEET

REVISIONS			
DATE	DESCRIPTION	DATE	DESCRIPTION

JAMES E. BRADFORD, P.E.  
P.E. LICENSE NUMBER 68276  
DEWBERRY ENGINEERS INC.  
800 NORTH MAGNOLIA AVENUE, STE. 1000  
ORLANDO, FL 32803

POLK COUNTY PUBLIC WORKS DEPARTMENT		
ROAD NO.	COUNTY	FINANCIAL PROJECT ID
557	POLK	18-73

**SIGNING AND PAVEMENT  
MARKING PLAN**

SHEET  
NO.  
S-13

THE OFFICIAL RECORD OF THIS SHEET IS THE ELECTRONIC FILE DIGITALLY SIGNED AND SEALED UNDER RULE 61G15-23.004, F.A.C.

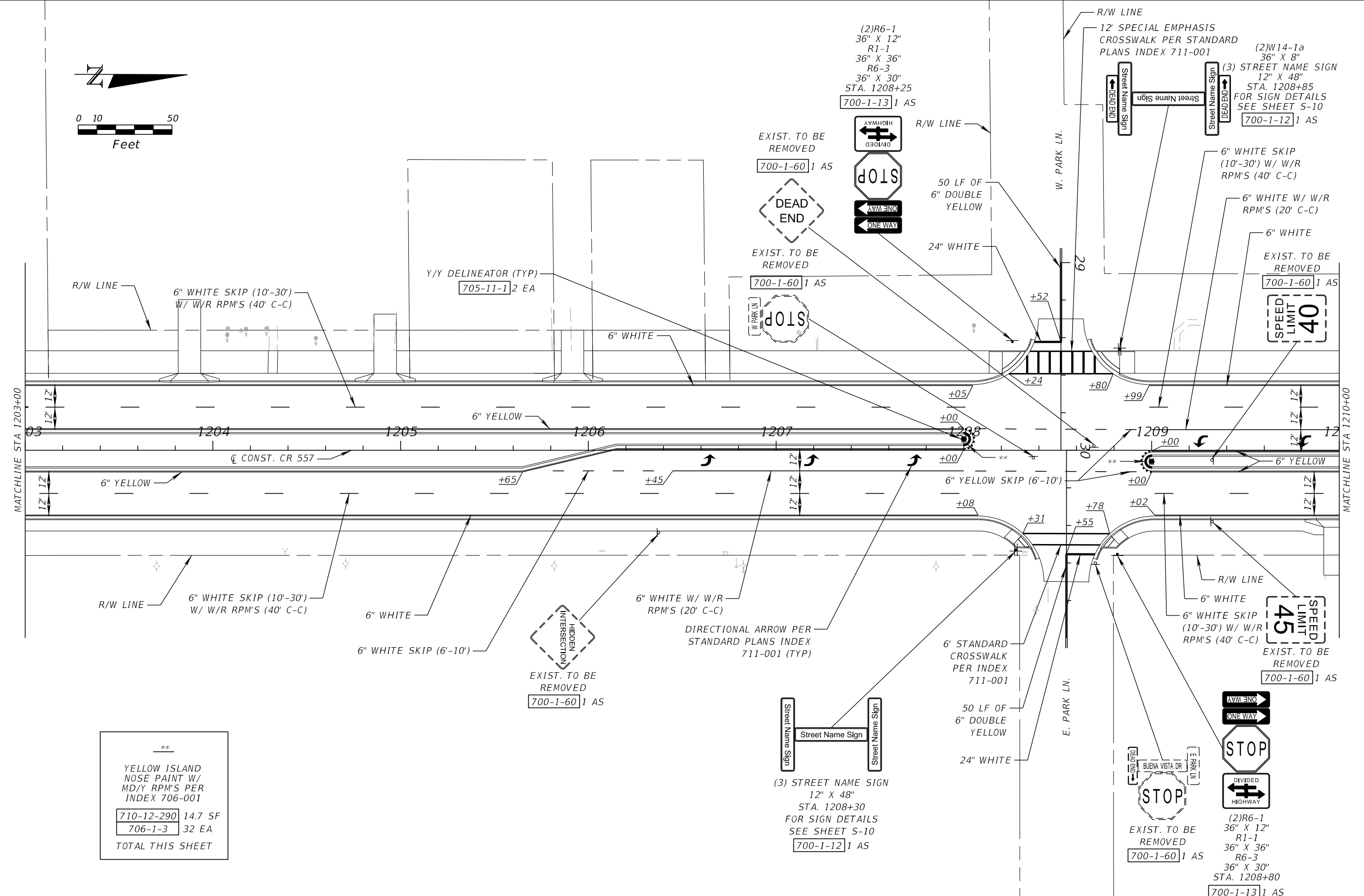
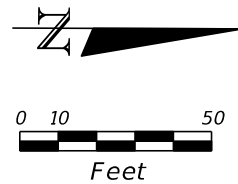

\*\*

YELLOW ISLAND NOSE PAINT W/ MD/Y RPM'S PER INDEX 706-001

710-12-290	14.7 SF
706-1-3	32 EA

TOTAL THIS SHEET

REVISIONS			
DATE	DESCRIPTION	DATE	DESCRIPTION

JAMES E. BRADFORD, P.E.  
 P.E. LICENSE NUMBER 68276  
 DEWBERRY ENGINEERS INC.  
 800 NORTH MAGNOLIA AVENUE, STE. 1000  
 ORLANDO, FL 32803

POLK COUNTY PUBLIC WORKS DEPARTMENT		
ROAD NO.	COUNTY	FINANCIAL PROJECT ID
557	POLK	18-73

**SIGNING AND PAVEMENT MARKING PLAN**

SHEET NO.  
S-14

THE OFFICIAL RECORD OF THIS SHEET IS THE ELECTRONIC FILE DIGITALLY SIGNED AND SEALED UNDER RULE 61G15-23.004, F.A.C.

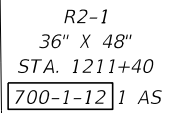
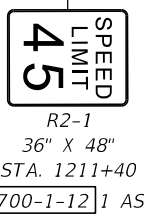
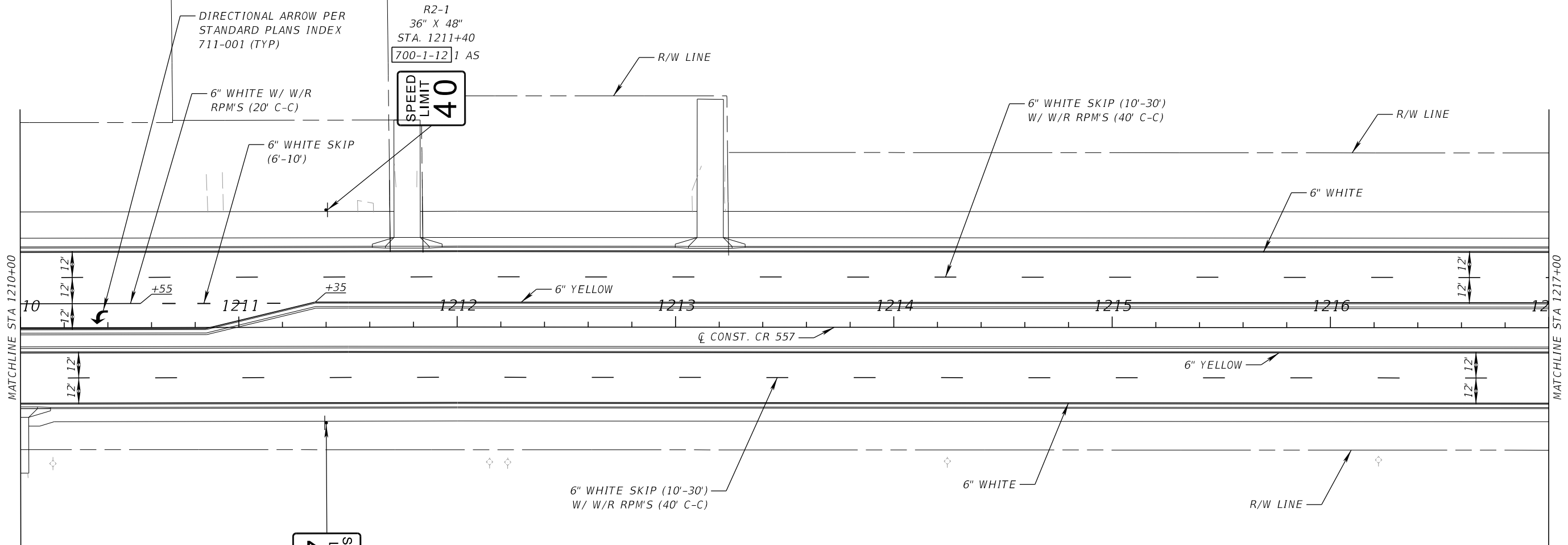
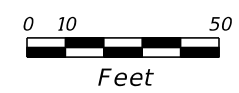

MATCHLINE STA 1210+00

MATCHLINE STA 1217+00

REVISIONS			
DATE	DESCRIPTION	DATE	DESCRIPTION

JAMES E. BRADFORD, P.E.  
 P.E. LICENSE NUMBER 68276  
 DEWBERRY ENGINEERS INC.  
 800 NORTH MAGNOLIA AVENUE, STE. 1000  
 ORLANDO, FL 32803

POLK COUNTY PUBLIC WORKS DEPARTMENT		
ROAD NO.	COUNTY	FINANCIAL PROJECT ID
557	POLK	18-73

**SIGNING AND PAVEMENT  
MARKING PLAN**

SHEET NO.  
S-15

THE OFFICIAL RECORD OF THIS SHEET IS THE ELECTRONIC FILE DIGITALLY SIGNED AND SEALED UNDER RULE 61G15-23.004, F.A.C.

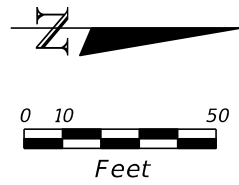

(3) OM1-3  
18" X 18"  
R6-1  
54" X 18"  
STA. 1223+60  
700-1-11 4 AS

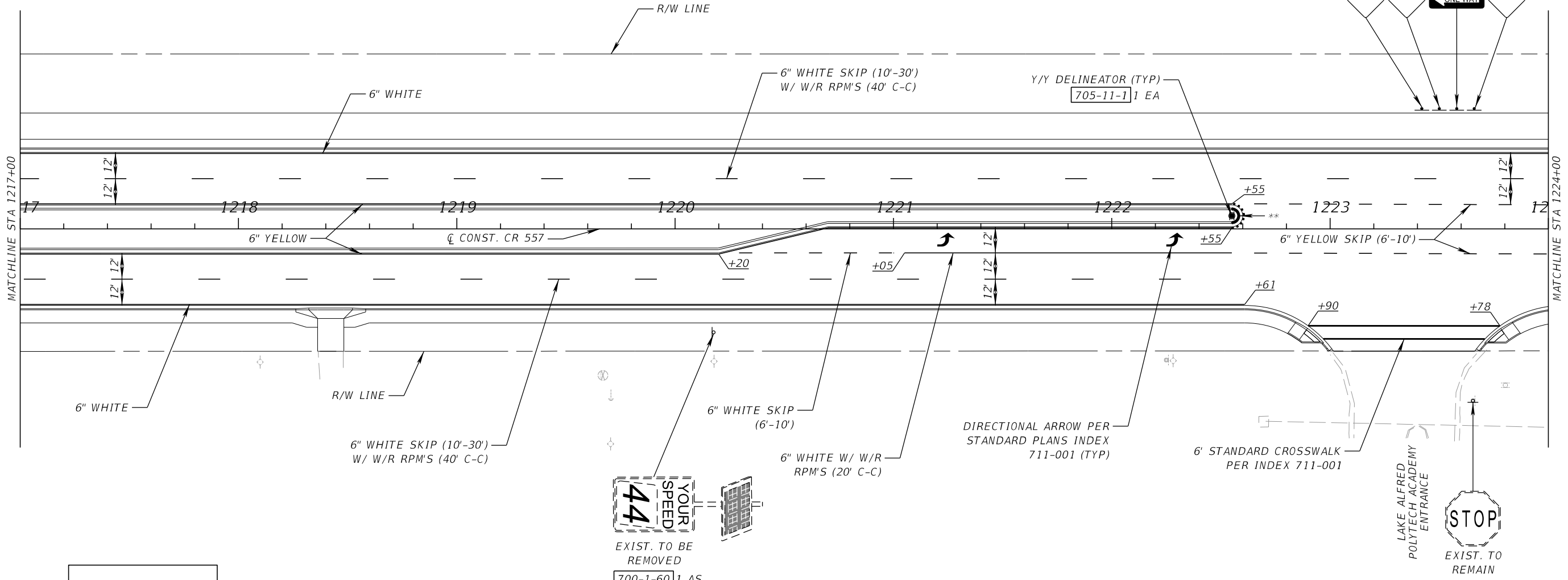
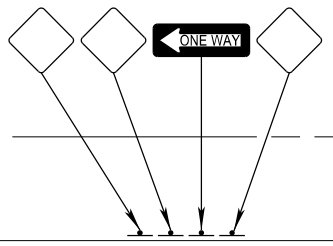

\*\*  
YELLOW ISLAND  
NOSE PAINT W/  
MD/Y RPM'S PER  
INDEX 706-001  
710-12-290 7.4 SF  
706-1-3 16 EA  
TOTAL THIS SHEET

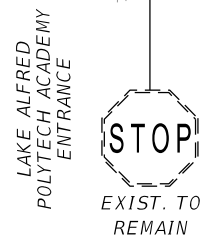
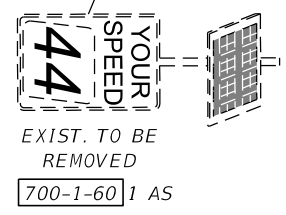

REVISIONS				JAMES E. BRADFORD, P.E. P.E. LICENSE NUMBER 68276 DEWBERRY ENGINEERS INC. 800 NORTH MAGNOLIA AVENUE, STE. 1000 ORLANDO, FL 32803	POLK COUNTY PUBLIC WORKS DEPARTMENT			SIGNING AND PAVEMENT MARKING PLAN	SHEET NO.
DATE	DESCRIPTION	DATE	DESCRIPTION		ROAD NO.	COUNTY	FINANCIAL PROJECT ID		
						557	POLK		18-73

THE OFFICIAL RECORD OF THIS SHEET IS THE ELECTRONIC FILE DIGITALLY SIGNED AND SEALED UNDER RULE 61G15-23.004, F.A.C.



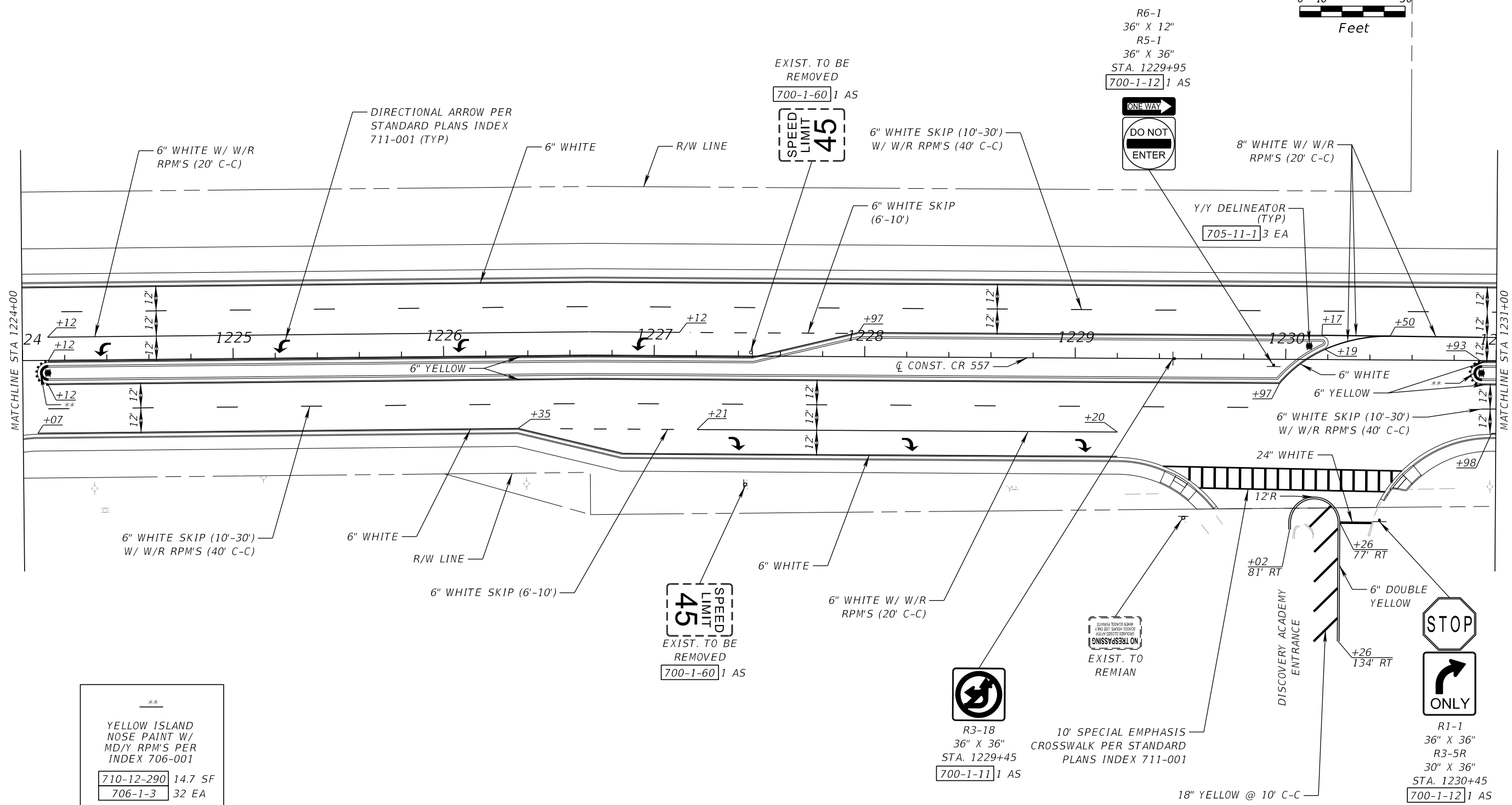
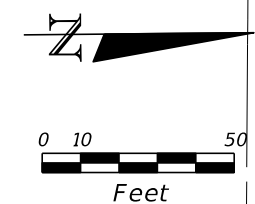

\*\*  
 YELLOW ISLAND  
 NOSE PAINT W/  
 MD/Y RPM'S PER  
 INDEX 706-001  
 710-12-290 14.7 SF  
 706-1-3 32 EA  
 TOTAL THIS SHEET

REVISIONS				JAMES E. BRADFORD, P.E. P.E. LICENSE NUMBER 68276 DEWBERRY ENGINEERS INC. 800 NORTH MAGNOLIA AVENUE, STE. 1000 ORLANDO, FL 32803	POLK COUNTY PUBLIC WORKS DEPARTMENT			<b>SIGNING AND PAVEMENT          MARKING PLAN</b>	SHEET NO.
DATE	DESCRIPTION	DATE	DESCRIPTION		ROAD NO.	COUNTY	FINANCIAL PROJECT ID		
					557	POLK	18-73		S-17

THE OFFICIAL RECORD OF THIS SHEET IS THE ELECTRONIC FILE DIGITALLY SIGNED AND SEALED UNDER RULE 61G15-23.004, F.A.C.

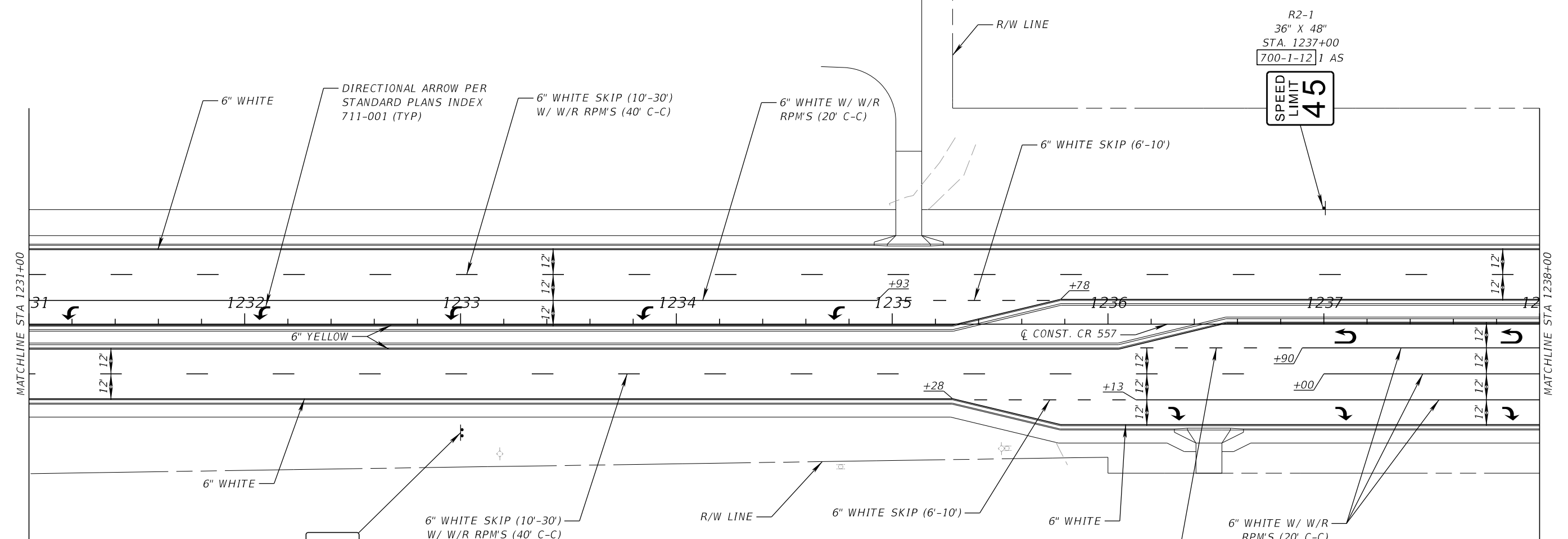
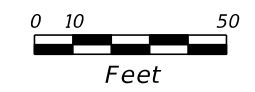

R2-1  
36" X 48"  
STA. 1237+00  
700-1-12 1 AS

SPEED  
LIMIT  
**45**

GM-7  
SIGN 107  
6'-0" X 2'-6"  
STA. 1233+00  
FOR SIGN DETAILS  
SEE SHEET S-68  
700-2-12 1 AS

**Evenhouse Rd  
NEXT SIGNAL**

REVISIONS				JAMES E. BRADFORD, P.E. P.E. LICENSE NUMBER 68276 DEWBERRY ENGINEERS INC. 800 NORTH MAGNOLIA AVENUE, STE. 1000 ORLANDO, FL 32803	POLK COUNTY PUBLIC WORKS DEPARTMENT			SIGNING AND PAVEMENT MARKING PLAN	SHEET NO.
DATE	DESCRIPTION	DATE	DESCRIPTION		ROAD NO.	COUNTY	FINANCIAL PROJECT ID		
						557	POLK		18-73

THE OFFICIAL RECORD OF THIS SHEET IS THE ELECTRONIC FILE DIGITALLY SIGNED AND SEALED UNDER RULE 61G15-23.004, F.A.C.

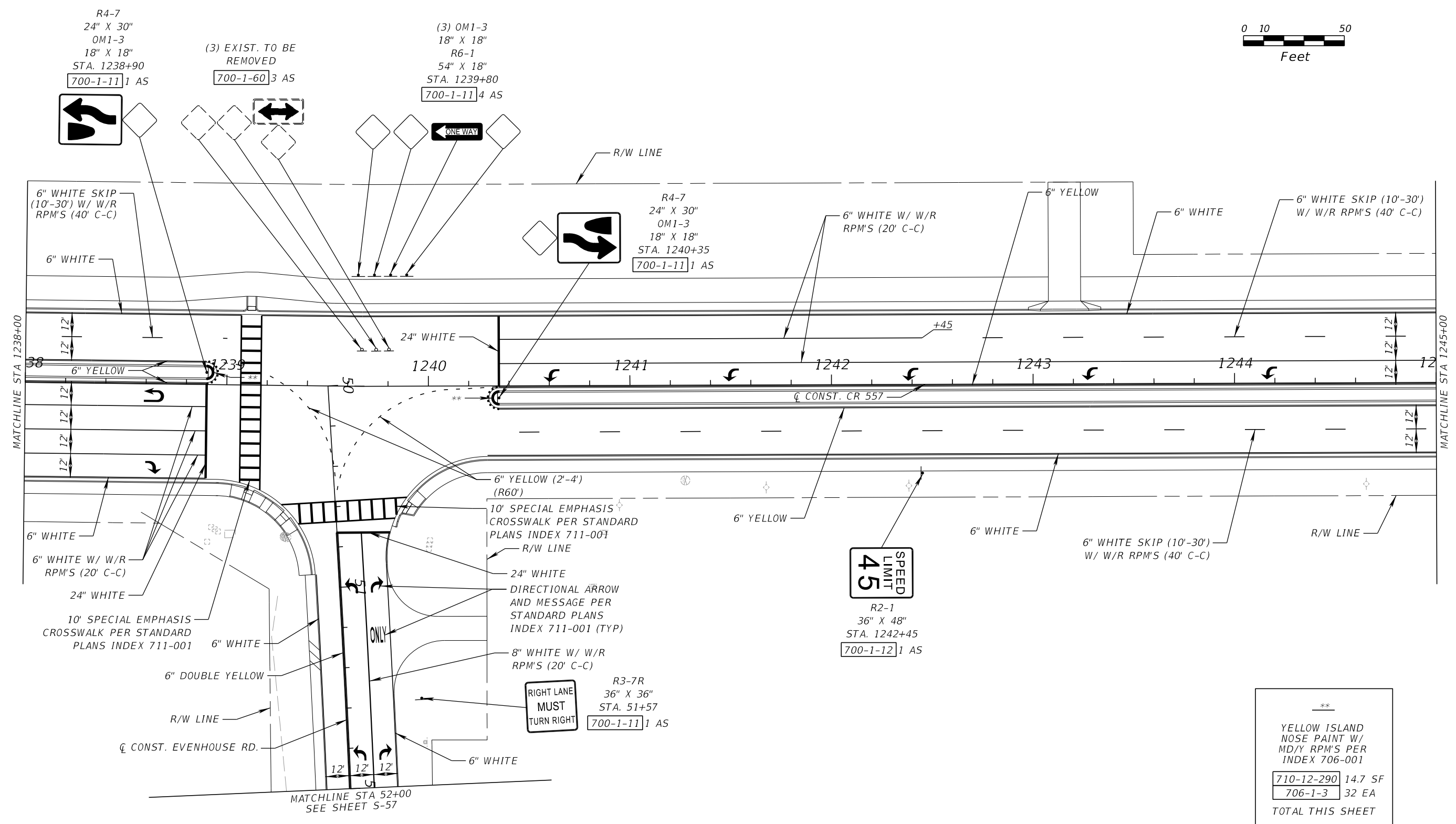
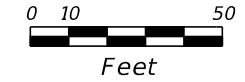

\*\*

YELLOW ISLAND  
NOSE PAINT W/  
MD/Y RPM'S PER  
INDEX 706-001

710-12-290	14.7 SF
706-1-3	32 EA

TOTAL THIS SHEET

REVISIONS			
DATE	DESCRIPTION	DATE	DESCRIPTION

JAMES E. BRADFORD, P.E.  
P.E. LICENSE NUMBER 68276  
DEWBERRY ENGINEERS INC.  
800 NORTH MAGNOLIA AVENUE, STE. 1000  
ORLANDO, FL 32803

POLK COUNTY PUBLIC WORKS DEPARTMENT		
ROAD NO.	COUNTY	FINANCIAL PROJECT ID
557	POLK	18-73

**SIGNING AND PAVEMENT  
MARKING PLAN**

SHEET  
NO.  
**S-19**

THE OFFICIAL RECORD OF THIS SHEET IS THE ELECTRONIC FILE DIGITALLY SIGNED AND SEALED UNDER RULE 61G15-23.004, F.A.C.

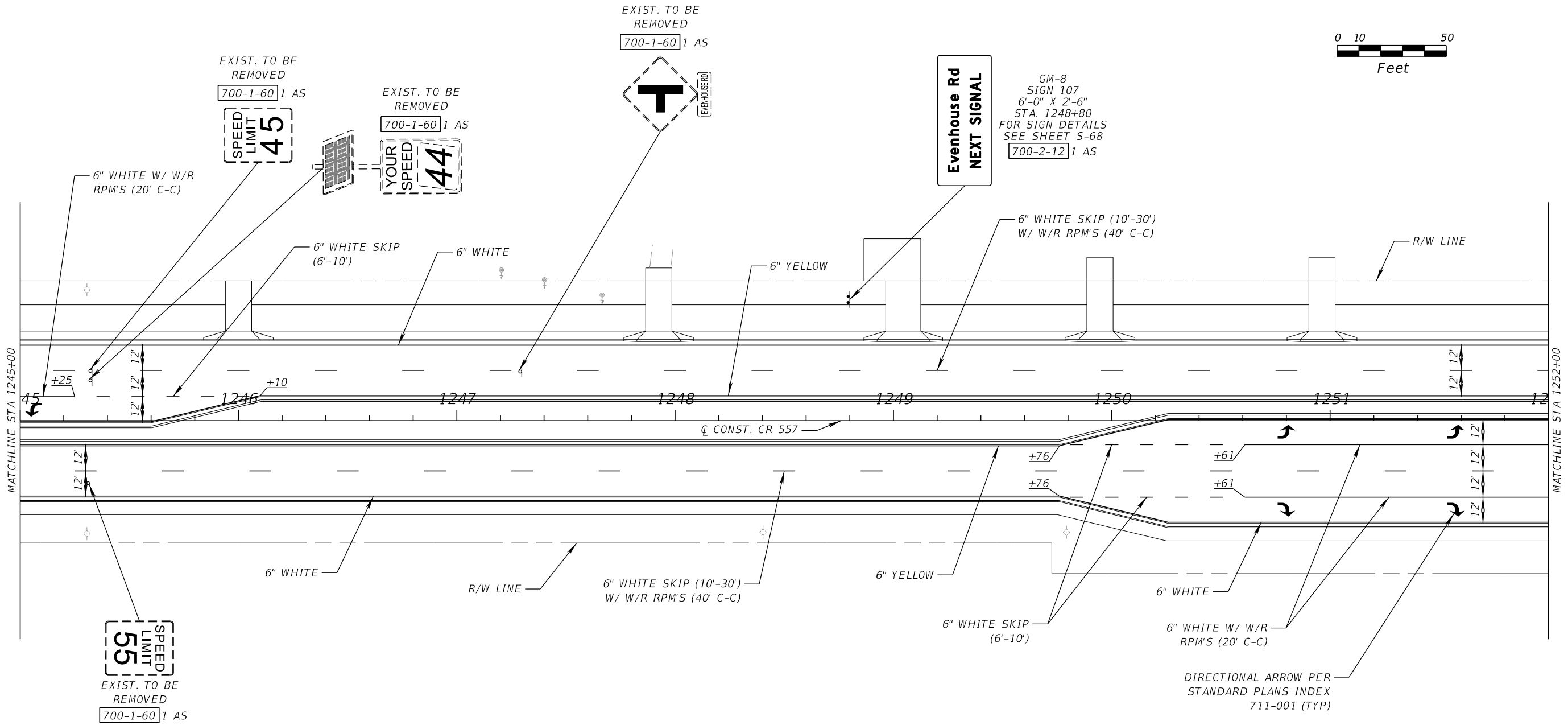
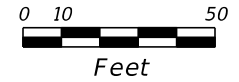

EXIST. TO BE REMOVED  
700-1-60 1 AS  
SPEED LIMIT 45

EXIST. TO BE REMOVED  
700-1-60 1 AS  
YOUR SPEED 44

EXIST. TO BE REMOVED  
700-1-60 1 AS  
T  
(EVENHOUSE RD)

Evenhouse Rd  
NEXT SIGNAL

GM-8  
SIGN 107  
6'-0" X 2'-6"  
STA. 1248+80  
FOR SIGN DETAILS  
SEE SHEET S-68  
700-2-12 1 AS

SPEED LIMIT 55  
EXIST. TO BE REMOVED  
700-1-60 1 AS

DIRECTIONAL ARROW PER  
STANDARD PLANS INDEX  
711-001 (TYP)

REVISIONS			
DATE	DESCRIPTION	DATE	DESCRIPTION

JAMES E. BRADFORD, P.E.  
P.E. LICENSE NUMBER 68276  
DEWBERRY ENGINEERS INC.  
800 NORTH MAGNOLIA AVENUE, STE. 1000  
ORLANDO, FL 32803

POLK COUNTY PUBLIC WORKS DEPARTMENT		
ROAD NO.	COUNTY	FINANCIAL PROJECT ID
557	POLK	18-73

**SIGNING AND PAVEMENT  
MARKING PLAN**

SHEET NO.  
S-20

THE OFFICIAL RECORD OF THIS SHEET IS THE ELECTRONIC FILE DIGITALLY SIGNED AND SEALED UNDER RULE 61G15-23.004, F.A.C.

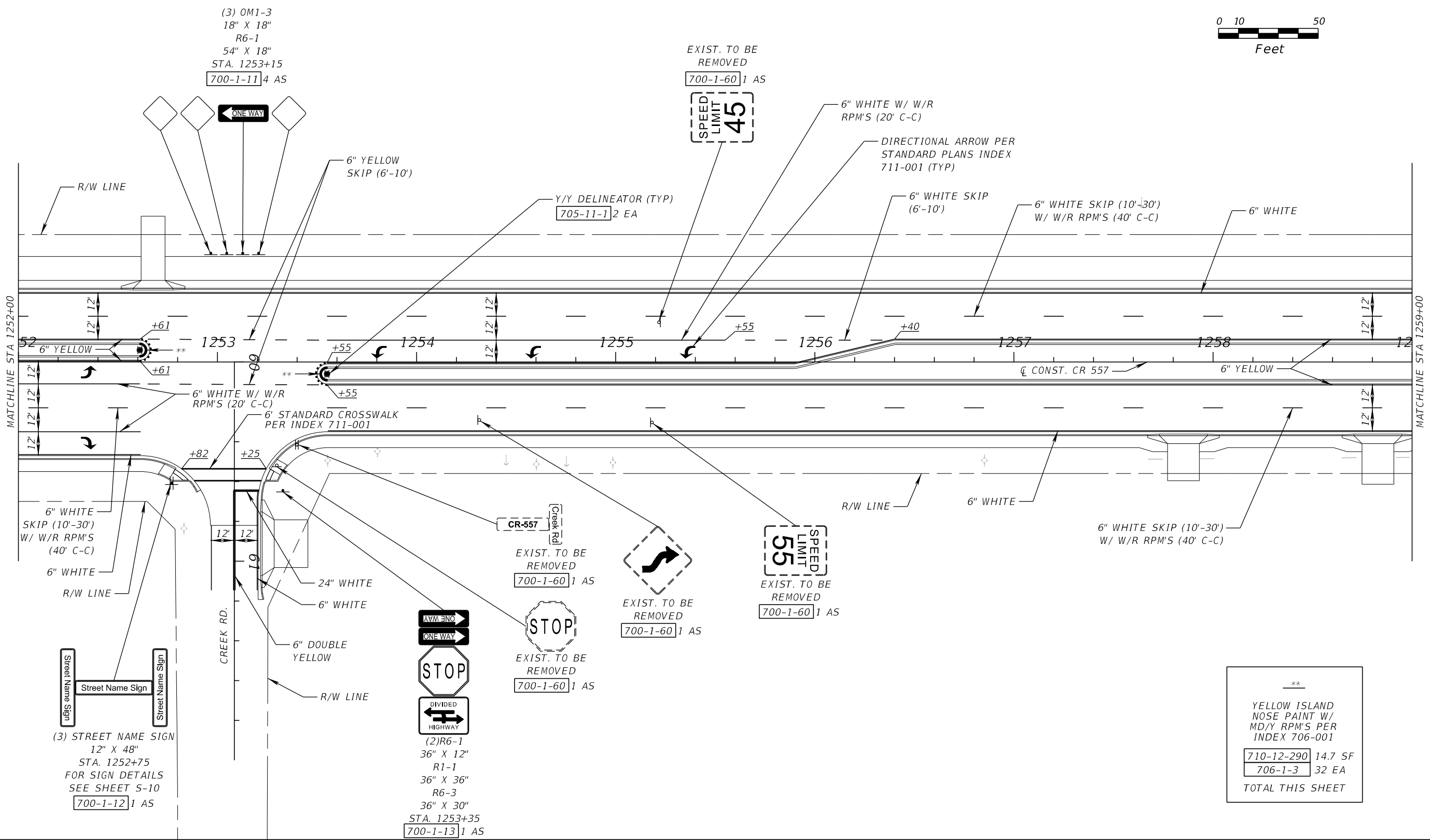
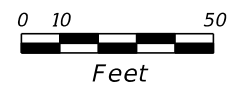

(3) OM1-3  
18" X 18"  
R6-1  
54" X 18"  
STA. 1253+15  
700-1-11 4 AS

EXIST. TO BE  
REMOVED  
700-1-60 1 AS

Y/Y DELINEATOR (TYP)  
705-11-1 2 EA

DIRECTIONAL ARROW PER  
STANDARD PLANS INDEX  
711-001 (TYP)

6" WHITE SKIP  
(6'-10')

6" WHITE SKIP (10'-30')  
W/ W/R RPM'S (40' C-C)

6" WHITE

6" WHITE W/ W/R  
RPM'S (20' C-C)

6' STANDARD CROSSWALK  
PER INDEX 711-001

CR-557  
Creek Rd

EXIST. TO BE  
REMOVED  
700-1-60 1 AS

EXIST. TO BE  
REMOVED  
700-1-60 1 AS

SPEED  
LIMIT  
55

EXIST. TO BE  
REMOVED  
700-1-60 1 AS

STOP

EXIST. TO BE  
REMOVED  
700-1-60 1 AS

ONE WAY

STOP

DIVIDED  
HIGHWAY

(2) R6-1  
36" X 12"  
R1-1  
36" X 36"  
R6-3  
36" X 30"  
STA. 1253+35  
700-1-13 1 AS

Street Name Sign

(3) STREET NAME SIGN  
12" X 48"  
STA. 1252+75  
FOR SIGN DETAILS  
SEE SHEET S-10  
700-1-12 1 AS

\*\*  
YELLOW ISLAND  
NOSE PAINT W/  
MD/Y RPM'S PER  
INDEX 706-001  
710-12-290 14.7 SF  
706-1-3 32 EA  
TOTAL THIS SHEET

REVISIONS			
DATE	DESCRIPTION	DATE	DESCRIPTION

JAMES E. BRADFORD, P.E.  
P.E. LICENSE NUMBER 68276  
DEWBERRY ENGINEERS INC.  
800 NORTH MAGNOLIA AVENUE, STE. 1000  
ORLANDO, FL 32803

POLK COUNTY PUBLIC WORKS DEPARTMENT		
ROAD NO.	COUNTY	FINANCIAL PROJECT ID
557	POLK	18-73

**SIGNING AND PAVEMENT  
MARKING PLAN**

SHEET  
NO.  
S-21

THE OFFICIAL RECORD OF THIS SHEET IS THE ELECTRONIC FILE DIGITALLY SIGNED AND SEALED UNDER RULE 61G15-23.004, F.A.C.

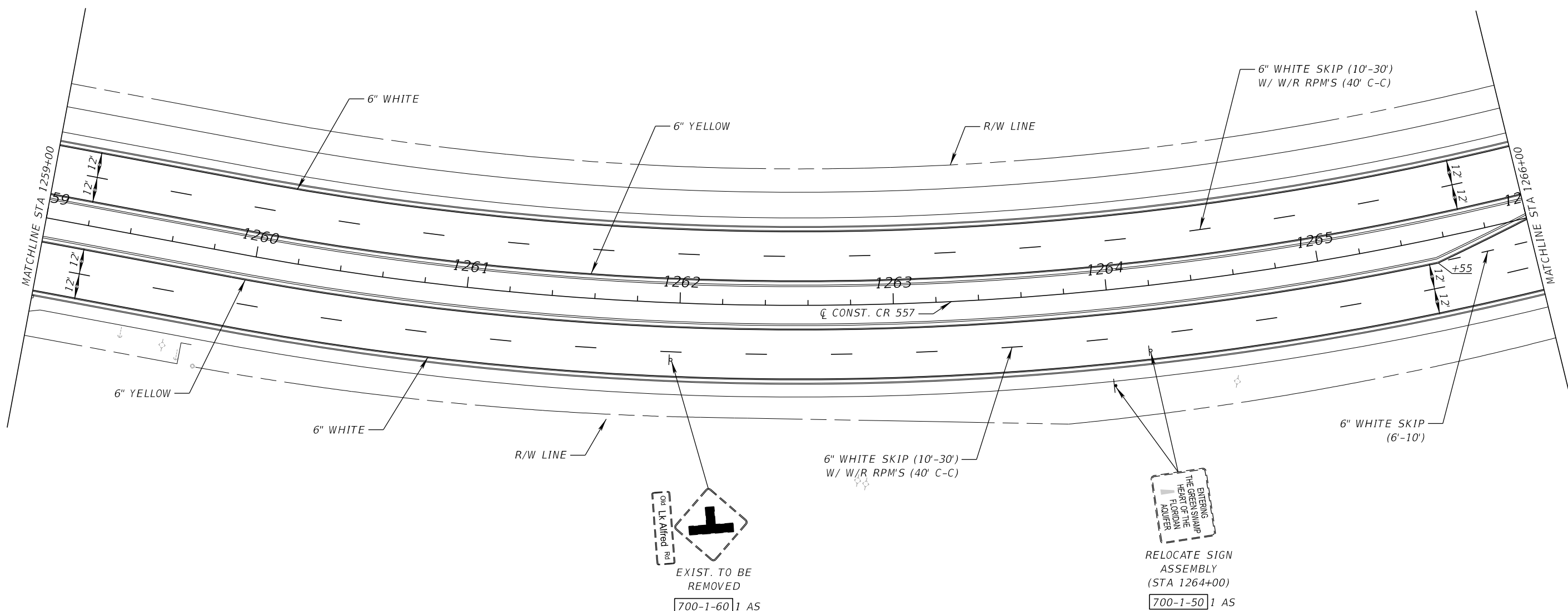
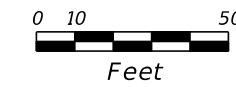

REVISIONS				JAMES E. BRADFORD, P.E. P.E. LICENSE NUMBER 68276 DEWBERRY ENGINEERS INC. 800 NORTH MAGNOLIA AVENUE, STE. 1000 ORLANDO, FL 32803	POLK COUNTY PUBLIC WORKS DEPARTMENT			SHEET NO.  S-22
DATE	DESCRIPTION	DATE	DESCRIPTION		ROAD NO.	COUNTY	FINANCIAL PROJECT ID	
					557	POLK	18-73	

**SIGNING AND PAVEMENT MARKING PLAN**

THE OFFICIAL RECORD OF THIS SHEET IS THE ELECTRONIC FILE DIGITALLY SIGNED AND SEALED UNDER RULE 61G15-23.004, F.A.C.



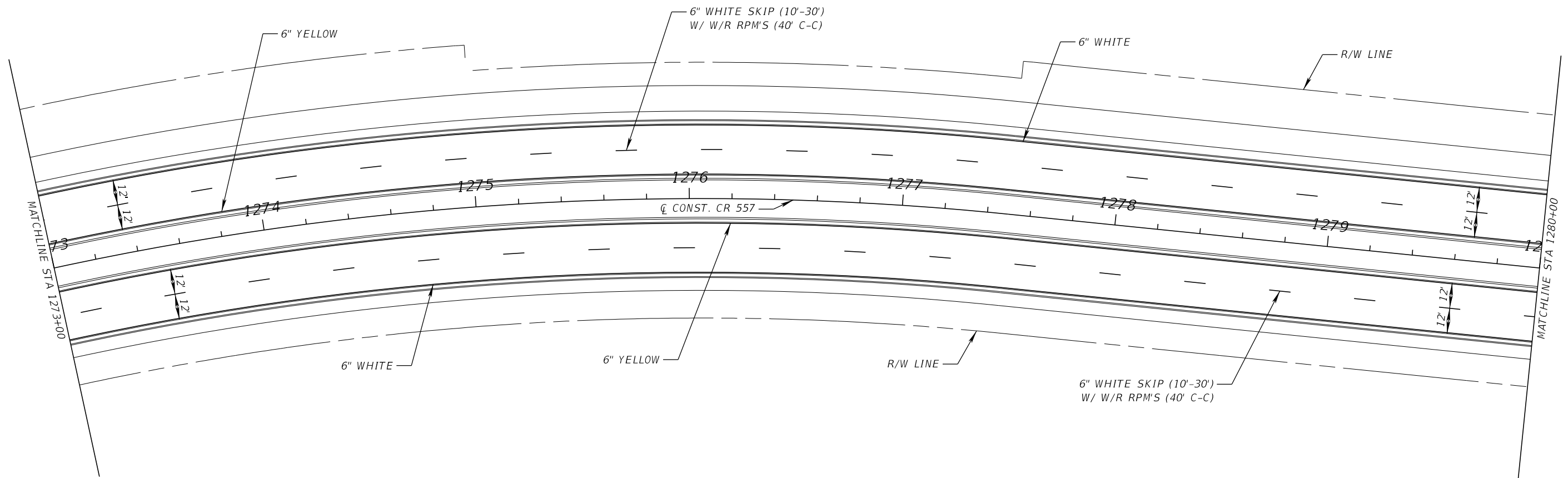
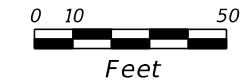

REVISIONS				JAMES E. BRADFORD, P.E. P.E. LICENSE NUMBER 68276 DEWBERRY ENGINEERS INC. 800 NORTH MAGNOLIA AVENUE, STE. 1000 ORLANDO, FL 32803	POLK COUNTY PUBLIC WORKS DEPARTMENT			SIGNING AND PAVEMENT MARKING PLAN	SHEET NO.
DATE	DESCRIPTION	DATE	DESCRIPTION		ROAD NO.	COUNTY	FINANCIAL PROJECT ID		
					557	POLK	18-73		S-24

THE OFFICIAL RECORD OF THIS SHEET IS THE ELECTRONIC FILE DIGITALLY SIGNED AND SEALED UNDER RULE 61G15-23.004, F.A.C.



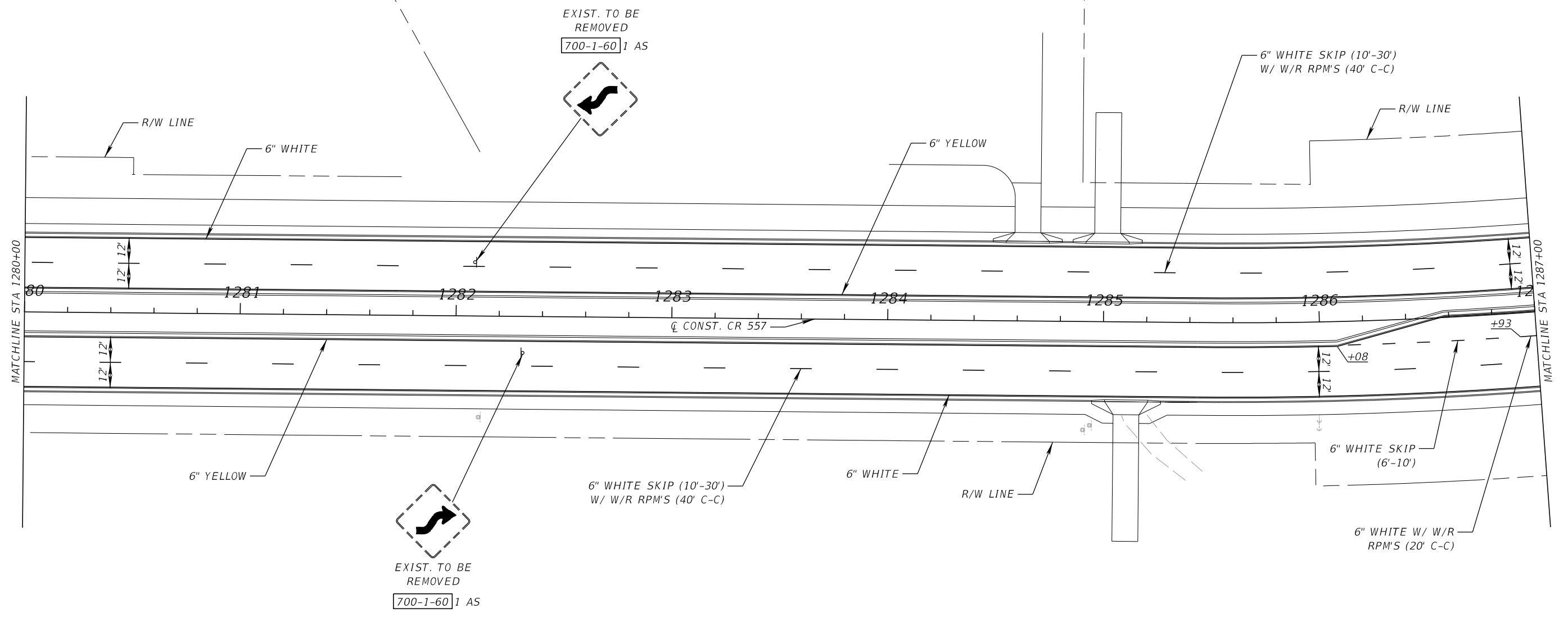
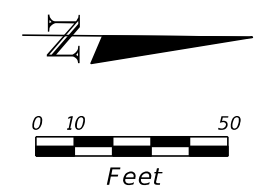

REVISIONS				JAMES E. BRADFORD, P.E. P.E. LICENSE NUMBER 68276 DEWBERRY ENGINEERS INC. 800 NORTH MAGNOLIA AVENUE, STE. 1000 ORLANDO, FL 32803	POLK COUNTY PUBLIC WORKS DEPARTMENT			<b>SIGNING AND PAVEMENT            MARKING PLAN</b>	SHEET NO.
DATE	DESCRIPTION	DATE	DESCRIPTION		ROAD NO.	COUNTY	FINANCIAL PROJECT ID		
					557	POLK	18-73		S-25

THE OFFICIAL RECORD OF THIS SHEET IS THE ELECTRONIC FILE DIGITALLY SIGNED AND SEALED UNDER RULE 61G15-23.004, F.A.C.

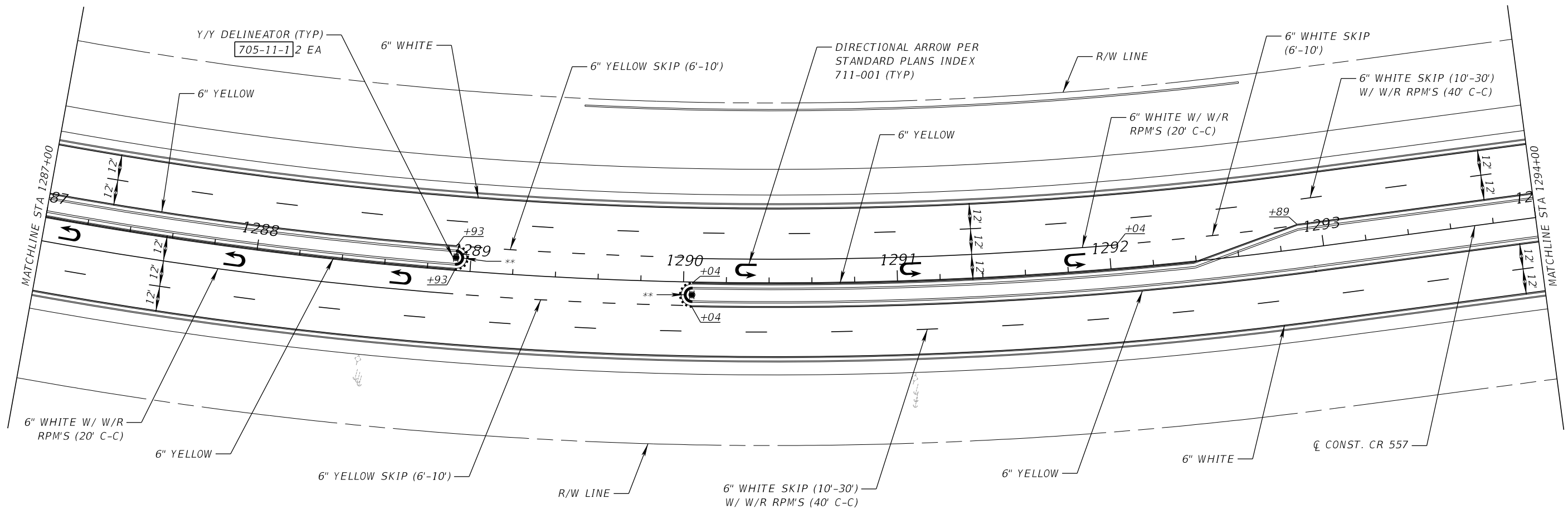
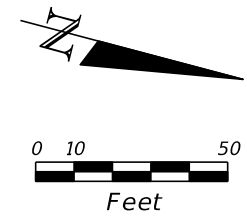

**	
YELLOW ISLAND NOSE PAINT W/ MD/Y RPM'S PER INDEX 706-001	
710-12-290	14.7 SF
706-1-3	32 EA
TOTAL THIS SHEET	

REVISIONS				JAMES E. BRADFORD, P.E. P.E. LICENSE NUMBER 68276 DEWBERRY ENGINEERS INC. 800 NORTH MAGNOLIA AVENUE, STE. 1000 ORLANDO, FL 32803	POLK COUNTY PUBLIC WORKS DEPARTMENT			<b>SIGNING AND PAVEMENT MARKING PLAN</b>	SHEET NO.  S-26
DATE	DESCRIPTION	DATE	DESCRIPTION		ROAD NO.	COUNTY	FINANCIAL PROJECT ID		
					557	POLK	18-73		

THE OFFICIAL RECORD OF THIS SHEET IS THE ELECTRONIC FILE DIGITALLY SIGNED AND SEALED UNDER RULE 61G15-23.004, F.A.C.

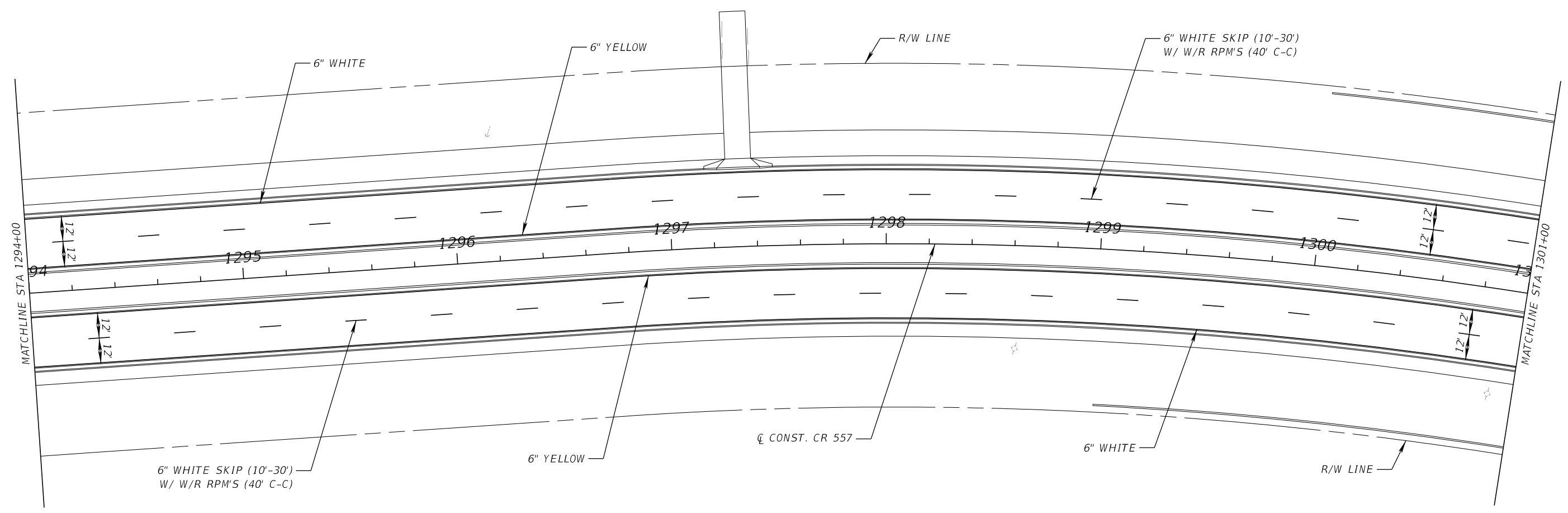
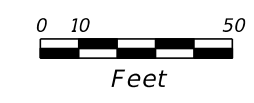

REVISIONS				JAMES E. BRADFORD, P.E. P.E. LICENSE NUMBER 68276 DEWBERRY ENGINEERS INC. 800 NORTH MAGNOLIA AVENUE, STE. 1000 ORLANDO, FL 32803	POLK COUNTY PUBLIC WORKS DEPARTMENT			<b>SIGNING AND PAVEMENT MARKING PLAN</b>	SHEET NO.
DATE	DESCRIPTION	DATE	DESCRIPTION		ROAD NO.	COUNTY	FINANCIAL PROJECT ID		S-27
					557	POLK	18-73		

THE OFFICIAL RECORD OF THIS SHEET IS THE ELECTRONIC FILE DIGITALLY SIGNED AND SEALED UNDER RULE 61G15-23.004, F.A.C.

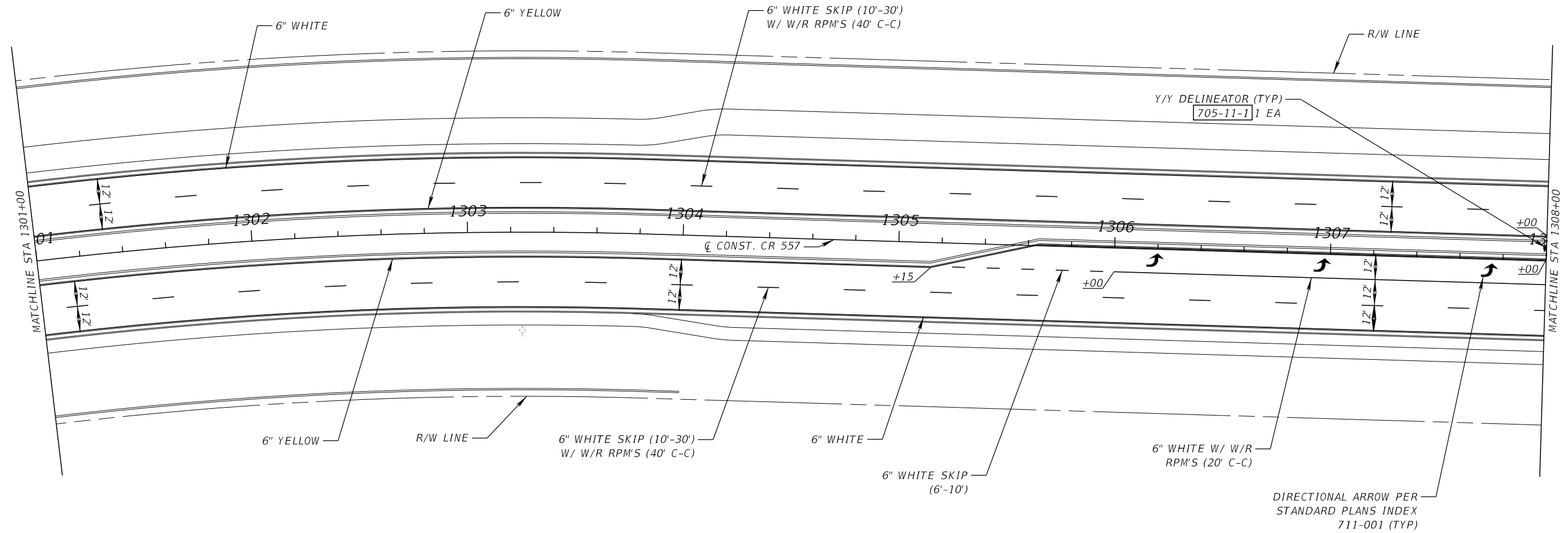
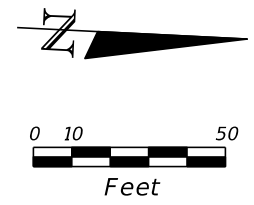

REVISIONS				JAMES E. BRADFORD, P.E. P.E. LICENSE NUMBER 68276 DEWBERRY ENGINEERS INC. 800 NORTH MAGNOLIA AVENUE, STE. 1000 ORLANDO, FL 32803	POLK COUNTY PUBLIC WORKS DEPARTMENT			<b>SIGNING AND PAVEMENT MARKING PLAN</b>	SHEET NO.
DATE	DESCRIPTION	DATE	DESCRIPTION		ROAD NO.	COUNTY	FINANCIAL PROJECT ID		
						557	POLK		18-73

THE OFFICIAL RECORD OF THIS SHEET IS THE ELECTRONIC FILE DIGITALLY SIGNED AND SEALED UNDER RULE 61G15-23.004, F.A.C.



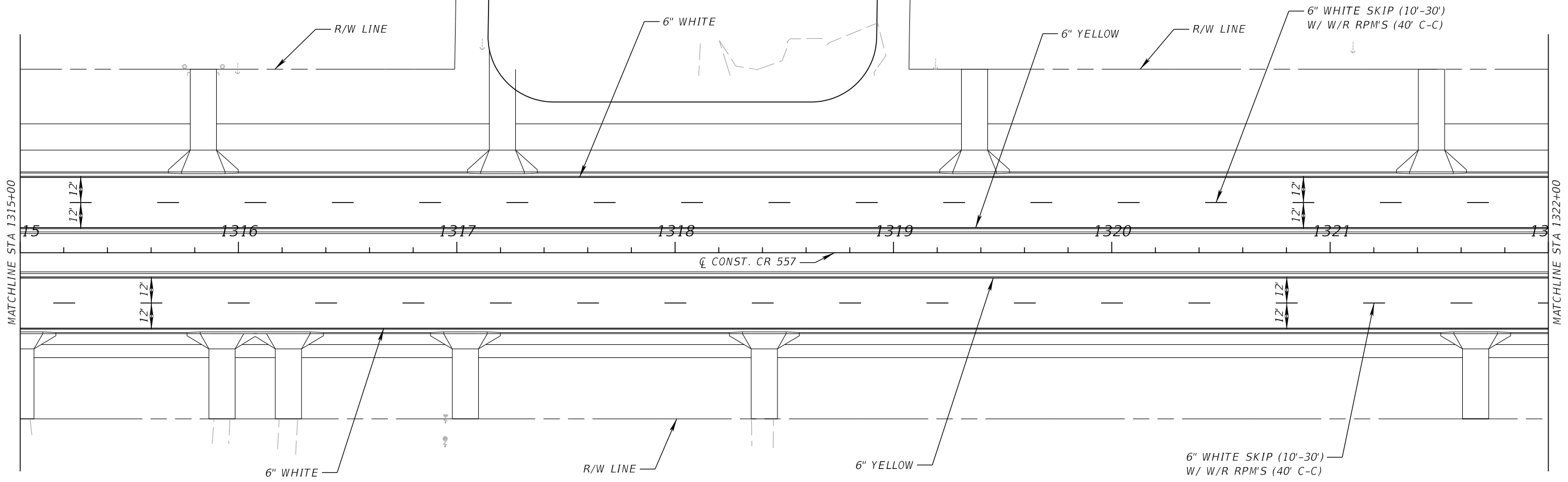
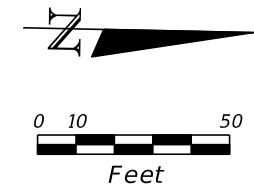

REVISIONS				JAMES E. BRADFORD, P.E. P.E. LICENSE NUMBER 68276 DEWBERRY ENGINEERS INC. 800 NORTH MAGNOLIA AVENUE, STE. 1000 ORLANDO, FL 32803	POLK COUNTY PUBLIC WORKS DEPARTMENT			<b>SIGNING AND PAVEMENT            MARKING PLAN</b>	SHEET NO.  S-30
DATE	DESCRIPTION	DATE	DESCRIPTION		ROAD NO.	COUNTY	FINANCIAL PROJECT ID		
						557	POLK		18-73

THE OFFICIAL RECORD OF THIS SHEET IS THE ELECTRONIC FILE DIGITALLY SIGNED AND SEALED UNDER RULE 61G15-23.004, F.A.C.

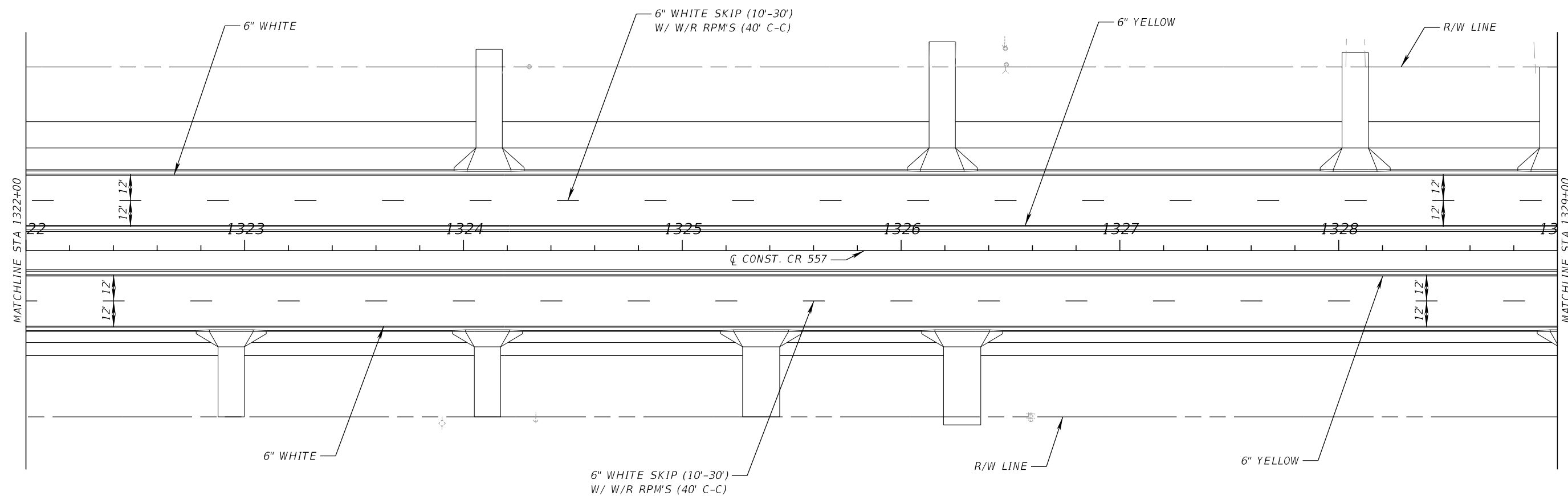
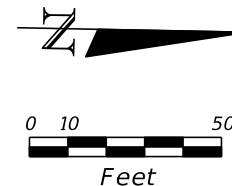

REVISIONS				JAMES E. BRADFORD, P.E. P.E. LICENSE NUMBER 68276 DEWBERRY ENGINEERS INC. 800 NORTH MAGNOLIA AVENUE, STE. 1000 ORLANDO, FL 32803	POLK COUNTY PUBLIC WORKS DEPARTMENT			SHEET NO.  S-31
DATE	DESCRIPTION	DATE	DESCRIPTION		ROAD NO.	COUNTY	FINANCIAL PROJECT ID	
					557	POLK	18-73	

**SIGNING AND PAVEMENT MARKING PLAN**

THE OFFICIAL RECORD OF THIS SHEET IS THE ELECTRONIC FILE DIGITALLY SIGNED AND SEALED UNDER RULE 61G15-23.004, F.A.C.

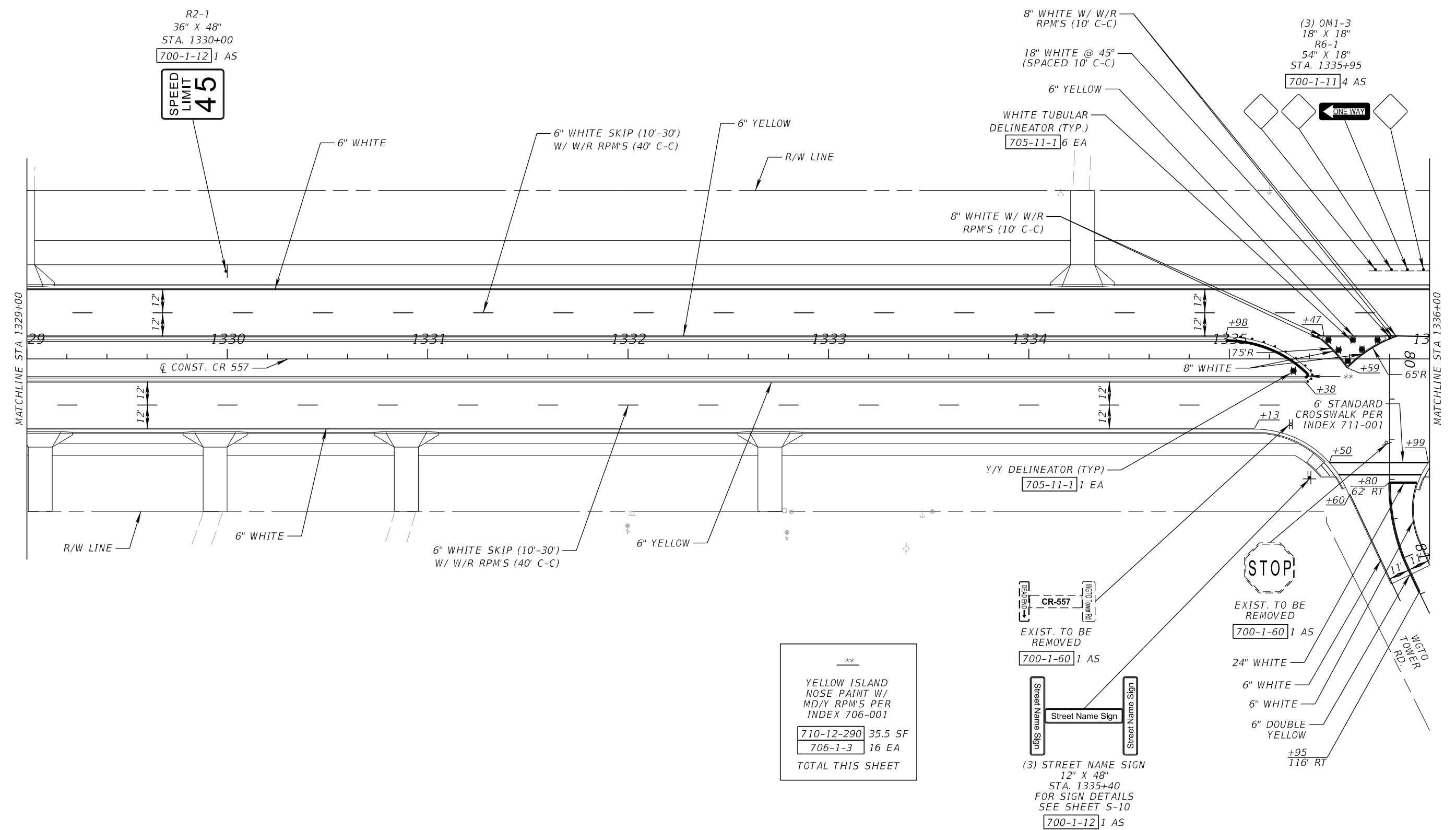
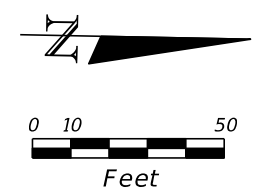

R2-1  
36" X 48"  
STA. 1330+00  
700-1-12 1 AS

**SPEED LIMIT 45**

(3) OM1-3  
18" X 18"  
R6-1  
54" X 18"  
STA. 1335+95  
700-1-11 4 AS

8" WHITE W/ W/R  
RPM'S (10' C-C)

18" WHITE @ 45°  
(SPACED 10' C-C)

6" YELLOW

WHITE TUBULAR  
DELINEATOR (TYP.)  
705-11-1 6 EA

8" WHITE W/ W/R  
RPM'S (10' C-C)

Y/Y DELINEATOR (TYP.)  
705-11-1 1 EA

**STOP**

CR-557  
EXIST. TO BE REMOVED  
700-1-60 1 AS

Street Name Sign  
Street Name Sign

(3) STREET NAME SIGN  
12" X 48"  
STA. 1335+40  
FOR SIGN DETAILS  
SEE SHEET S-10  
700-1-12 1 AS

\*\*

YELLOW ISLAND  
NOSE PAINT W/  
MD/Y RPM'S PER  
INDEX 706-001

710-12-290 35.5 SF  
706-1-3 16 EA  
TOTAL THIS SHEET

REVISIONS				JAMES E. BRADFORD, P.E. P.E. LICENSE NUMBER 68276 DEWBERRY ENGINEERS INC. 800 NORTH MAGNOLIA AVENUE, STE. 1000 ORLANDO, FL 32803	POLK COUNTY PUBLIC WORKS DEPARTMENT			SIGNING AND PAVEMENT MARKING PLAN	SHEET NO.
DATE	DESCRIPTION	DATE	DESCRIPTION		ROAD NO.	COUNTY	FINANCIAL PROJECT ID		
						557	POLK		18-73

THE OFFICIAL RECORD OF THIS SHEET IS THE ELECTRONIC FILE DIGITALLY SIGNED AND SEALED UNDER RULE 61G15-23.004, F.A.C.



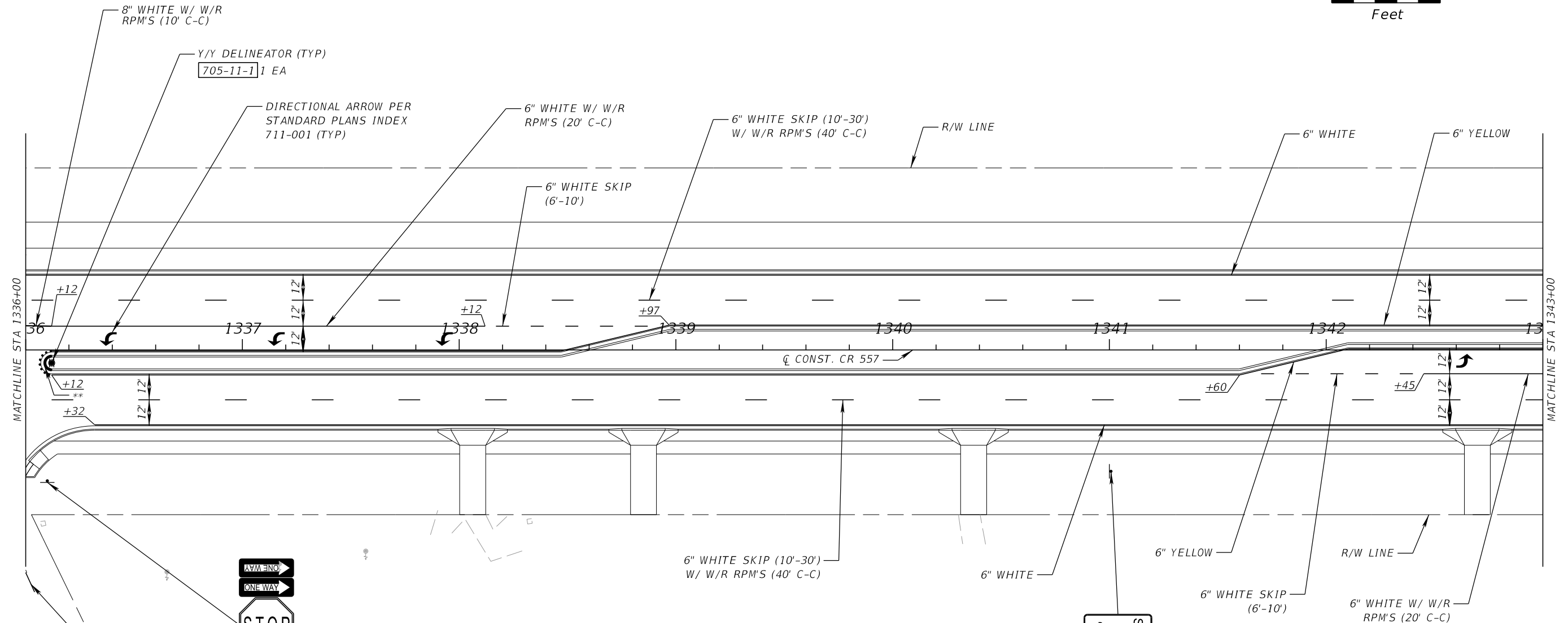
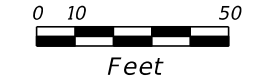

(2)R6-1  
36" X 12"  
R1-1  
36" X 36"  
R6-3  
36" X 30"  
STA. 1336+10  
700-1-13 1 AS

\*\*  
YELLOW ISLAND  
NOSE PAINT W/  
MD/Y RPM'S PER  
INDEX 706-001  
710-12-290 7.4 SF  
706-1-3 16 EA  
TOTAL THIS SHEET



R2-1  
36" X 48"  
STA. 1341+00  
700-1-12 1 AS

REVISIONS			
DATE	DESCRIPTION	DATE	DESCRIPTION

JAMES E. BRADFORD, P.E.  
P.E. LICENSE NUMBER 68276  
DEWBERRY ENGINEERS INC.  
800 NORTH MAGNOLIA AVENUE, STE. 1000  
ORLANDO, FL 32803

POLK COUNTY PUBLIC WORKS DEPARTMENT		
ROAD NO.	COUNTY	FINANCIAL PROJECT ID
557	POLK	18-73

**SIGNING AND PAVEMENT  
MARKING PLAN**

SHEET NO.  
S-33

THE OFFICIAL RECORD OF THIS SHEET IS THE ELECTRONIC FILE DIGITALLY SIGNED AND SEALED UNDER RULE 61G15-23.004, F.A.C.

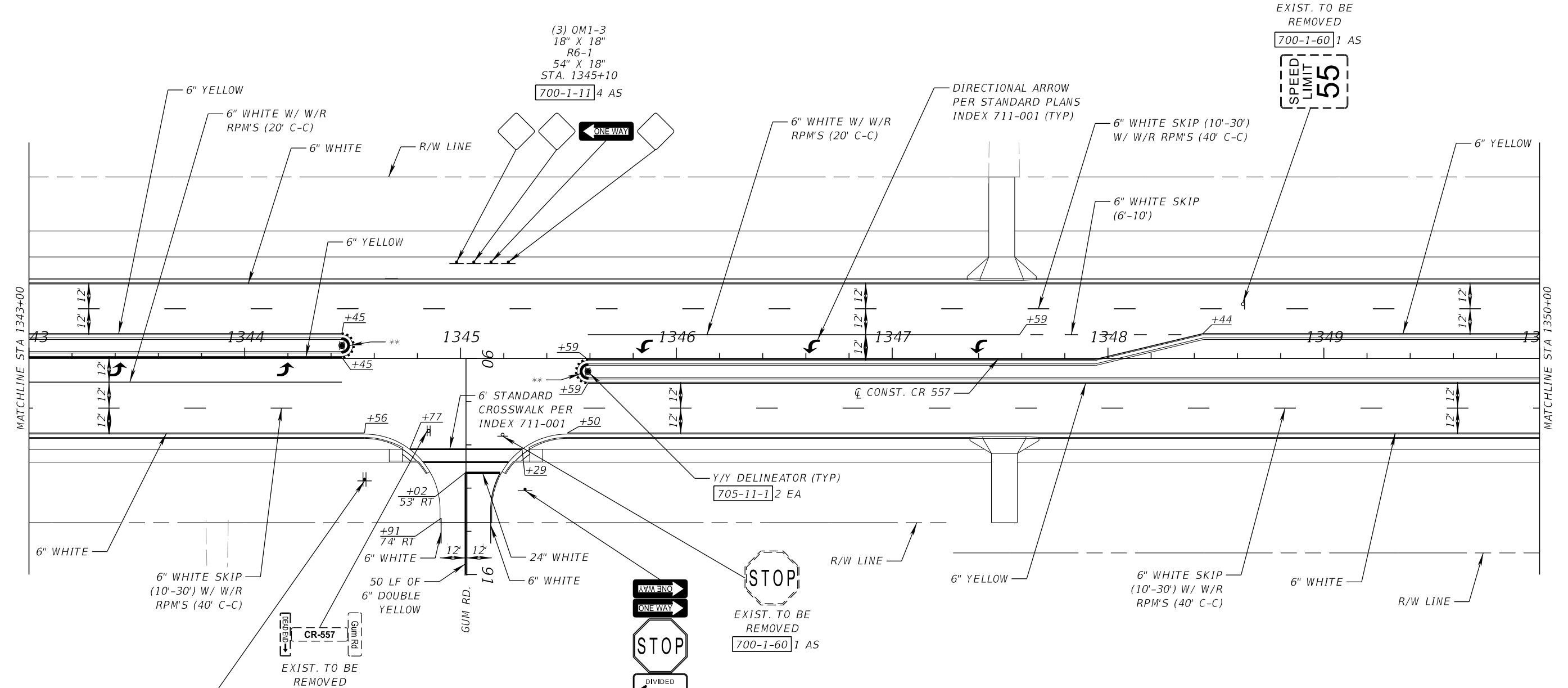
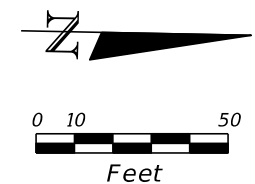

Street Name Sign  
Street Name Sign  
(3) STREET NAME SIGN  
12" X 48"  
STA. 1344+55  
FOR SIGN DETAILS  
SEE SHEET S-10  
700-1-12 1 AS

CR-557  
EXIST. TO BE REMOVED  
700-1-60 1 AS

(3) OM1-3  
18" X 18"  
R6-1  
54" X 18"  
STA. 1345+10  
700-1-11 4 AS

STOP  
ONE WAY  
DIVIDED HIGHWAY  
(2)R6-1  
36" X 12"  
R1-1  
36" X 36"  
R6-3  
36" X 30"  
STA. 1345+30  
700-1-13 1 AS

STOP  
EXIST. TO BE REMOVED  
700-1-60 1 AS

EXIST. TO BE REMOVED  
700-1-60 1 AS  
SPEED LIMIT  
55

\*\*  
YELLOW ISLAND  
NOSE PAINT W/  
MD/Y RPM'S PER  
INDEX 706-001  
710-12-290 14.7 SF  
706-1-3 32 EA  
TOTAL THIS SHEET

REVISIONS			
DATE	DESCRIPTION	DATE	DESCRIPTION

JAMES E. BRADFORD, P.E.  
P.E. LICENSE NUMBER 68276  
DEWBERRY ENGINEERS INC.  
800 NORTH MAGNOLIA AVENUE, STE. 1000  
ORLANDO, FL 32803

POLK COUNTY PUBLIC WORKS DEPARTMENT		
ROAD NO.	COUNTY	FINANCIAL PROJECT ID
557	POLK	18-73

**SIGNING AND PAVEMENT  
MARKING PLAN**

SHEET NO.  
S-34

THE OFFICIAL RECORD OF THIS SHEET IS THE ELECTRONIC FILE DIGITALLY SIGNED AND SEALED UNDER RULE 61G15-23.004, F.A.C.

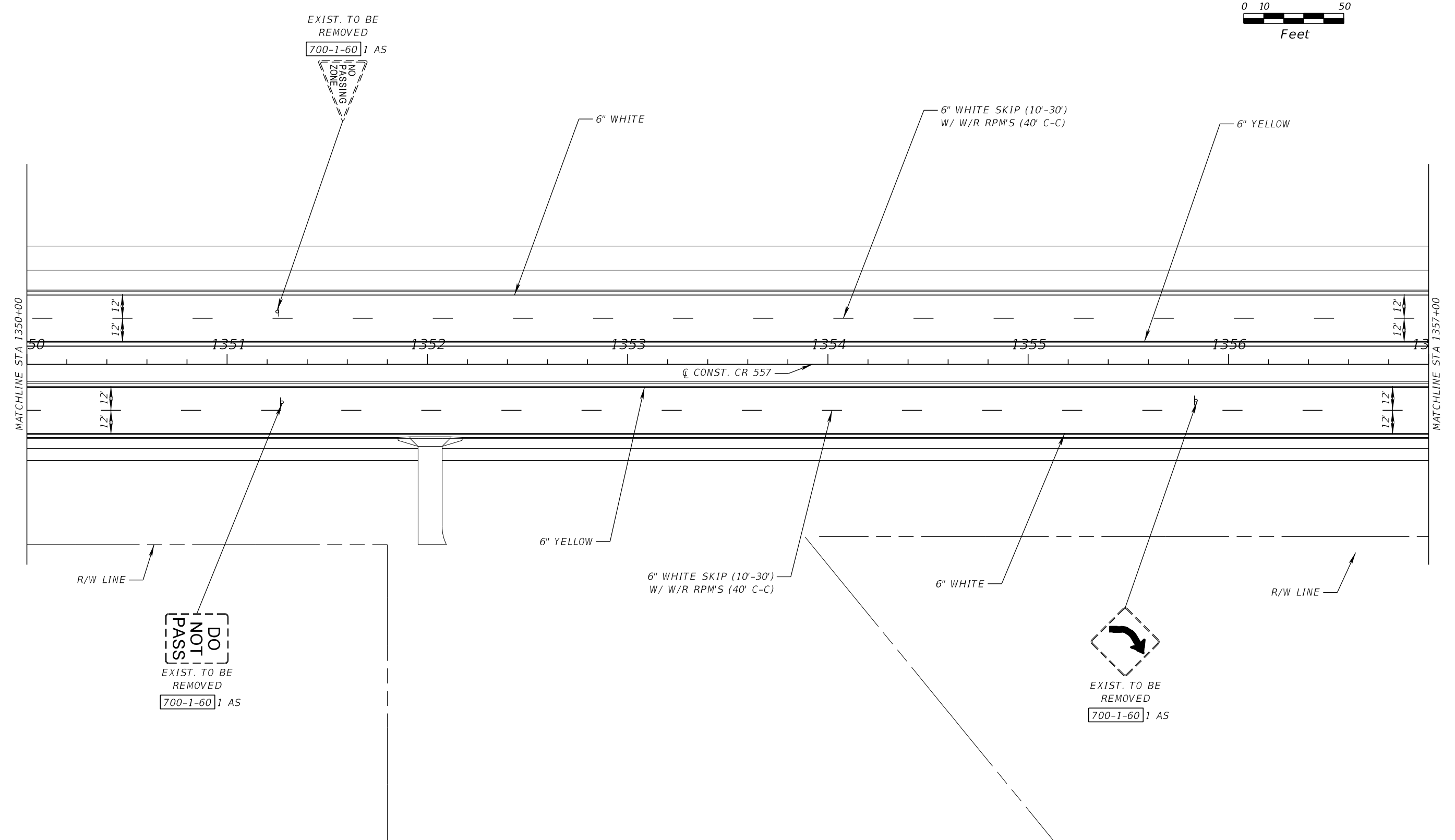
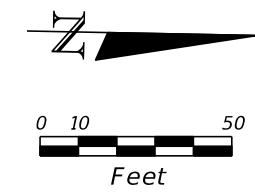

REVISIONS				JAMES E. BRADFORD, P.E. P.E. LICENSE NUMBER 68276 DEWBERRY ENGINEERS INC. 800 NORTH MAGNOLIA AVENUE, STE. 1000 ORLANDO, FL 32803	POLK COUNTY PUBLIC WORKS DEPARTMENT			<b>SIGNING AND PAVEMENT            MARKING PLAN</b>	SHEET NO.
DATE	DESCRIPTION	DATE	DESCRIPTION		ROAD NO.	COUNTY	FINANCIAL PROJECT ID		
					557	POLK	18-73		S-35

THE OFFICIAL RECORD OF THIS SHEET IS THE ELECTRONIC FILE DIGITALLY SIGNED AND SEALED UNDER RULE 61G15-23.004, F.A.C.

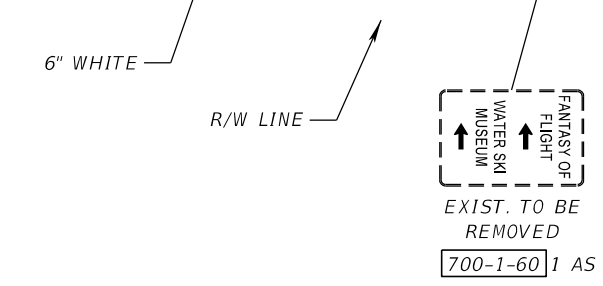
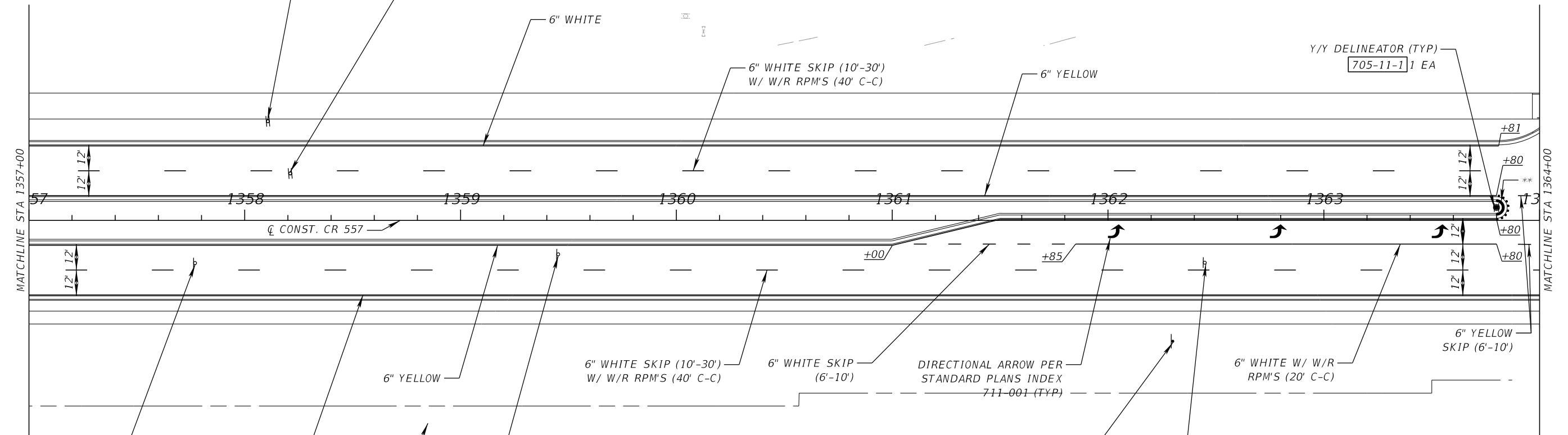
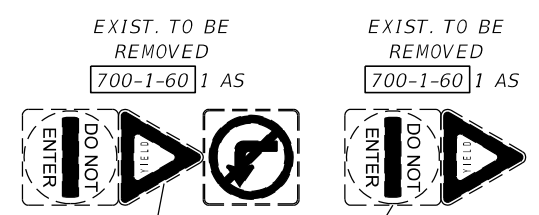
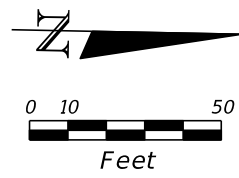

\*\*

YELLOW ISLAND  
NOSE PAINT W/  
MD/Y RPM'S PER  
INDEX 706-001

710-12-290 7.4 SF  
706-1-3 16 EA  
TOTAL THIS SHEET

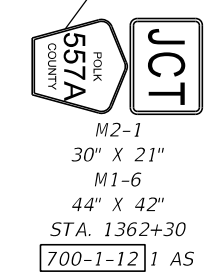

REVISIONS				JAMES E. BRADFORD, P.E. P.E. LICENSE NUMBER 68276 DEWBERRY ENGINEERS INC. 800 NORTH MAGNOLIA AVENUE, STE. 1000 ORLANDO, FL 32803	POLK COUNTY PUBLIC WORKS DEPARTMENT			<b>SIGNING AND PAVEMENT MARKING PLAN</b>	SHEET NO.
DATE	DESCRIPTION	DATE	DESCRIPTION		ROAD NO.	COUNTY	FINANCIAL PROJECT ID		
						557	POLK		18-73

THE OFFICIAL RECORD OF THIS SHEET IS THE ELECTRONIC FILE DIGITALLY SIGNED AND SEALED UNDER RULE 61G15-23.004, F.A.C.

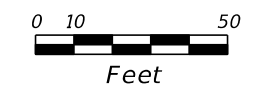

DIRECTIONAL ARROW PER STANDARD PLANS INDEX 711-001 (TYP)

YELLOW ISLAND NOSE PAINT W/ MD/Y RPM'S PER INDEX 706-001  
710-12-290 7.4 SF  
706-1-3 16 EA  
TOTAL THIS SHEET

EXIST. TO BE REMOVED 700-1-60 1 AS  
POLK COUNTY 557A  
EXIST. TO BE REMOVED 700-1-60 1 AS  
FANTASY OF FLIGHT WATER SKI MUSEUM

EXIST. TO BE REMOVED 700-1-60 1 AS  
DO NOT PASS

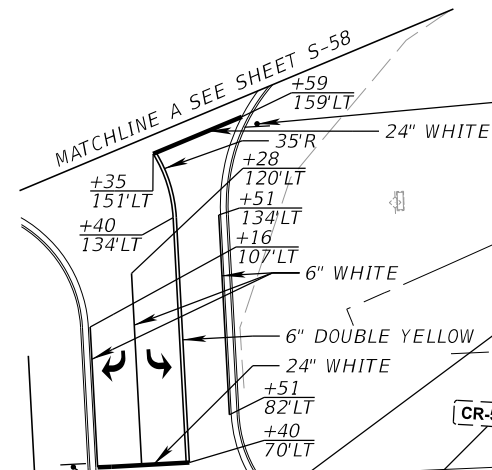

MATCHLINE STA 1364+00

MATCHLINE STA 1371+00

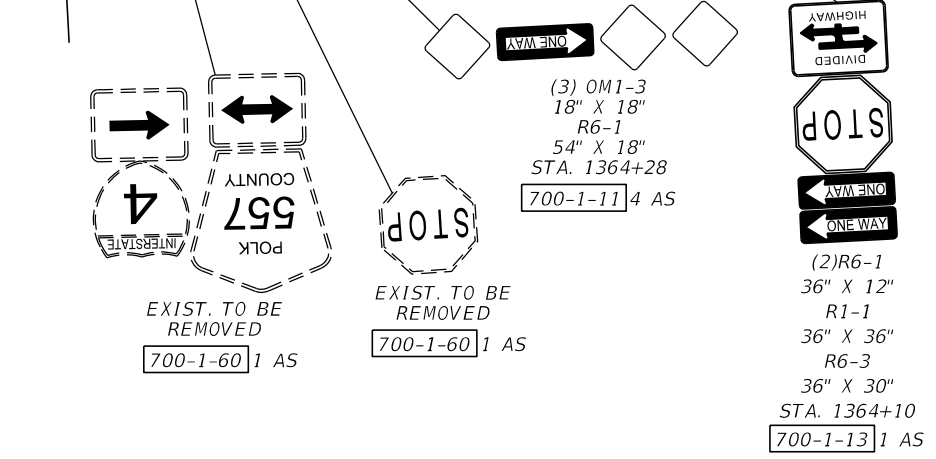

EXIST. TO BE REMOVED 700-1-60 1 AS  
POLK COUNTY 557 NORTH

W2-6 36" X 36"  
W13-1P 30" X 30"  
STA. 1366+30  
700-1-12 2 AS  
700-12-21 2 AS

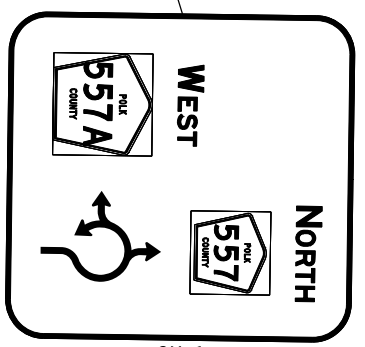

GM-1 SIGN 101 8'-6" X 9'-0" STA. 1368+30 FOR SIGN DETAILS SEE SHEET S-66 700-2-15 1 AS

EXIST. TO BE REMOVED 700-1-60 1 AS  
NO PASSING ZONE

R3-8 (MOD) 42" X 42" STA. 1370+85 FOR SIGN DETAILS, SEE SHEET S-67 700-1-12 2 AS

REVISIONS			
DATE	DESCRIPTION	DATE	DESCRIPTION

JAMES E. BRADFORD, P.E.  
P.E. LICENSE NUMBER 68276  
DEWBERRY ENGINEERS INC.  
800 NORTH MAGNOLIA AVENUE, STE. 1000  
ORLANDO, FL 32803

POLK COUNTY PUBLIC WORKS DEPARTMENT		
ROAD NO.	COUNTY	FINANCIAL PROJECT ID
557	POLK	18-73

**SIGNING AND PAVEMENT MARKING PLAN**

SHEET NO. S-37

THE OFFICIAL RECORD OF THIS SHEET IS THE ELECTRONIC FILE DIGITALLY SIGNED AND SEALED UNDER RULE 61G15-23.004, F.A.C.



SEE INTERSECTION DETAIL SHEET S-64 FOR ADDITIONAL INFORMATION

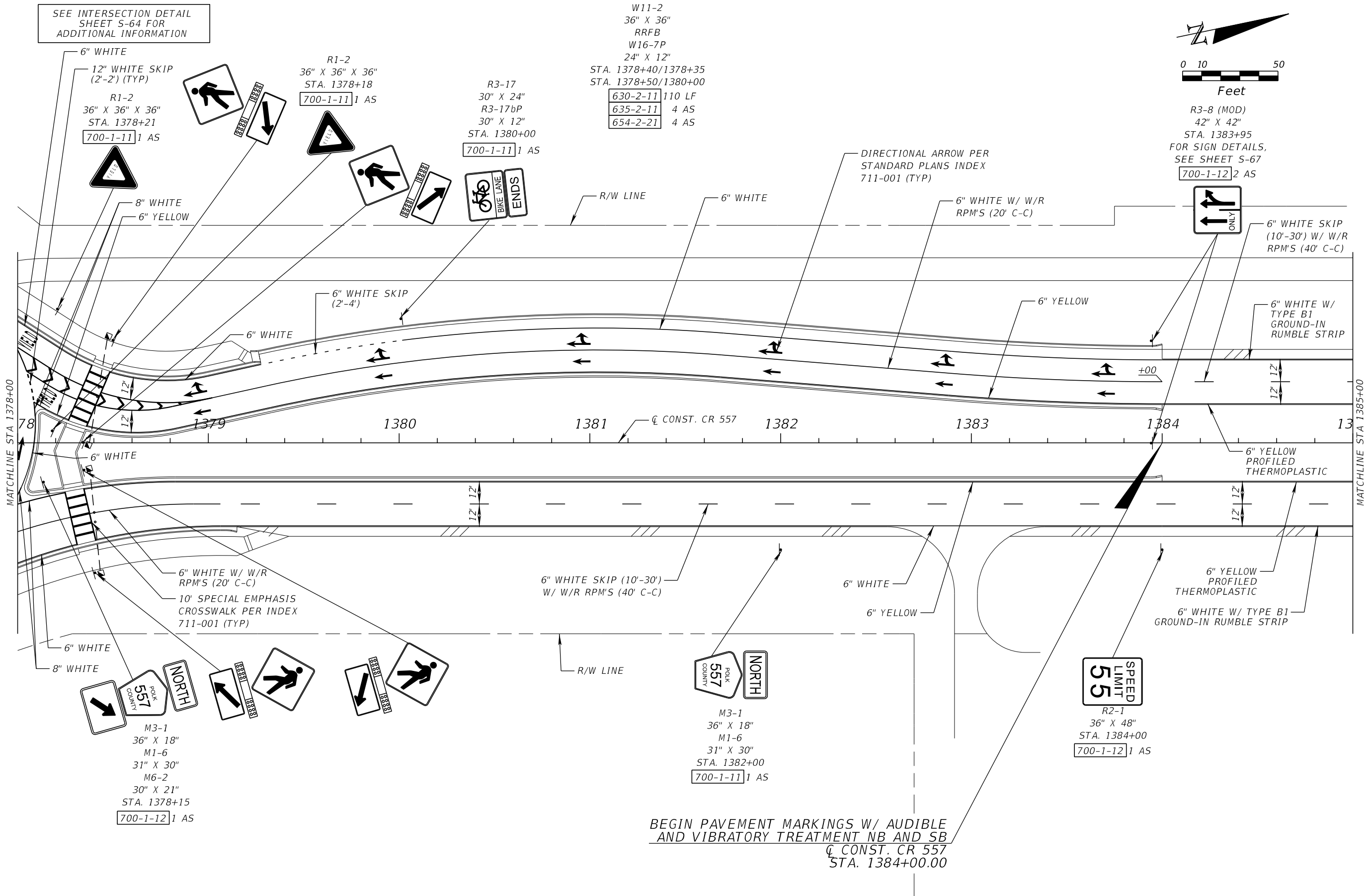
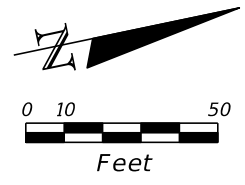

BEGIN PAVEMENT MARKINGS W/ AUDIBLE AND VIBRATORY TREATMENT NB AND SB  
 Q CONST. CR 557  
 STA. 1384+00.00

REVISIONS			
DATE	DESCRIPTION	DATE	DESCRIPTION

JAMES E. BRADFORD, P.E.  
 P.E. LICENSE NUMBER 68276  
 DEWBERRY ENGINEERS INC.  
 800 NORTH MAGNOLIA AVENUE, STE. 1000  
 ORLANDO, FL 32803

POLK COUNTY PUBLIC WORKS DEPARTMENT		
ROAD NO.	COUNTY	FINANCIAL PROJECT ID
557	POLK	18-73

**SIGNING AND PAVEMENT MARKING PLAN**

SHEET NO.  
S-39

THE OFFICIAL RECORD OF THIS SHEET IS THE ELECTRONIC FILE DIGITALLY SIGNED AND SEALED UNDER RULE 61G15-23.004, F.A.C.

GM-2  
SIGN 102  
8'-6" X 9'-0"  
STA. 1386+20  
FOR SIGN DETAILS  
SEE SHEET S-66  
700-2-15 1 AS

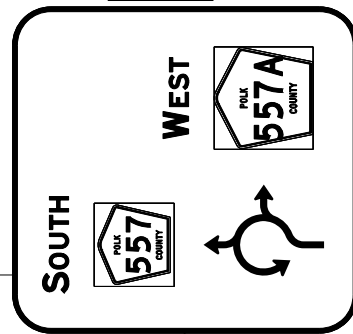

W2-6  
36" X 36"  
W13-1P  
30" X 30"  
STA. 1388+20  
700-1-12 2 AS  
700-12-21 2 AS



M2-1  
30" X 21"  
M1-6  
44" X 42"  
STA. 1390+20  
700-1-11 1 AS

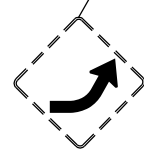
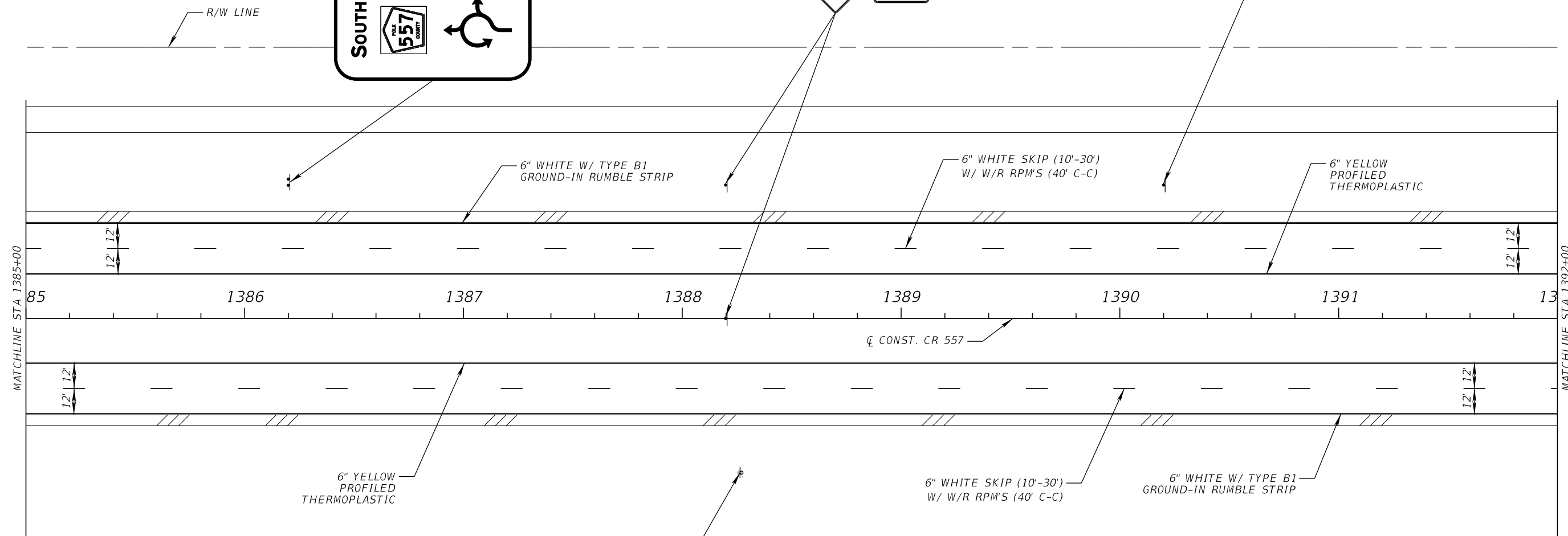
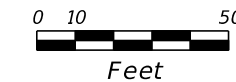

EXIST. TO BE  
REMOVED  
700-1-60 1 AS

REVISIONS				JAMES E. BRADFORD, P.E. P.E. LICENSE NUMBER 68276 DEWBERRY ENGINEERS INC. 800 NORTH MAGNOLIA AVENUE, STE. 1000 ORLANDO, FL 32803	POLK COUNTY PUBLIC WORKS DEPARTMENT			SIGNING AND PAVEMENT MARKING PLAN	SHEET NO.
DATE	DESCRIPTION	DATE	DESCRIPTION		ROAD NO.	COUNTY	FINANCIAL PROJECT ID		S-40
					557	POLK	18-73		

THE OFFICIAL RECORD OF THIS SHEET IS THE ELECTRONIC FILE DIGITALLY SIGNED AND SEALED UNDER RULE 61G15-23.004, F.A.C.



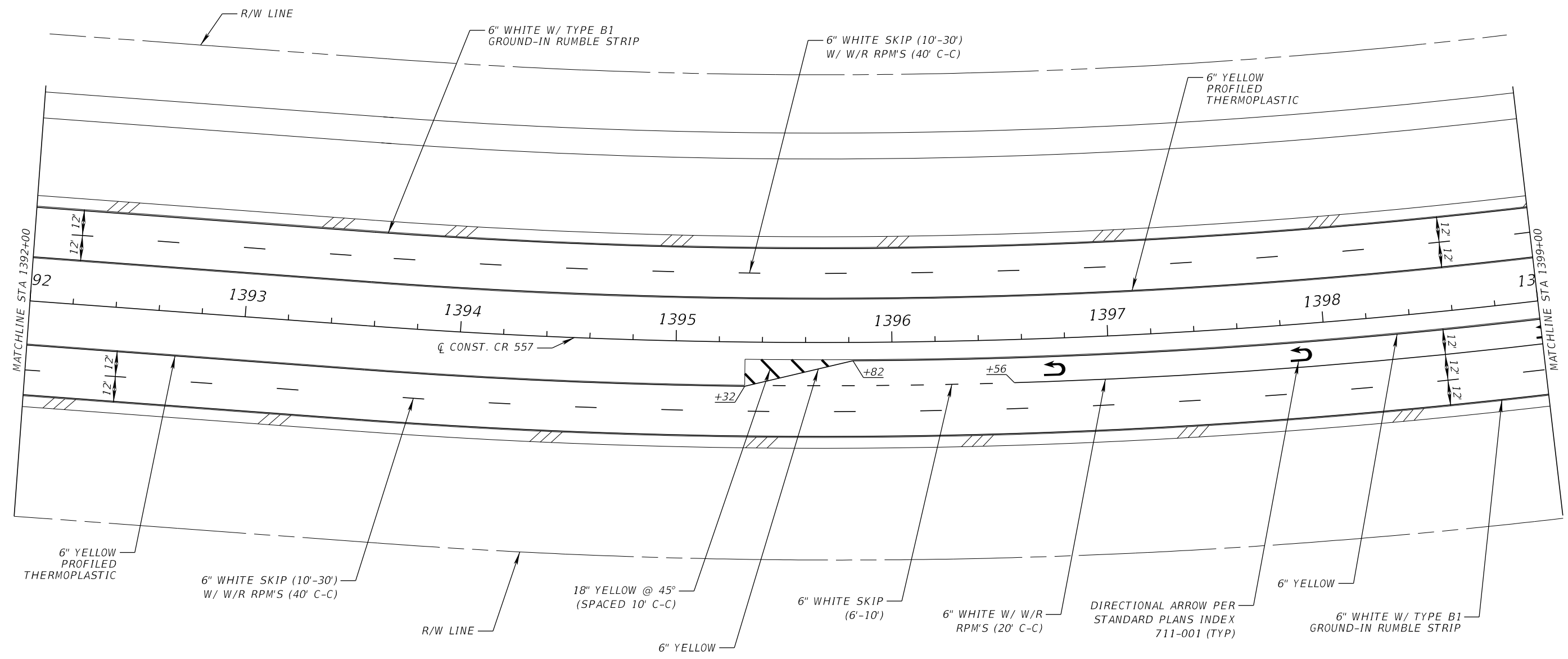
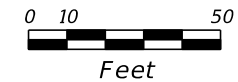

REVISIONS				JAMES E. BRADFORD, P.E. P.E. LICENSE NUMBER 68276 DEWBERRY ENGINEERS INC. 800 NORTH MAGNOLIA AVENUE, STE. 1000 ORLANDO, FL 32803	POLK COUNTY PUBLIC WORKS DEPARTMENT			SIGNING AND PAVEMENT MARKING PLAN	SHEET NO.
DATE	DESCRIPTION	DATE	DESCRIPTION		ROAD NO.	COUNTY	FINANCIAL PROJECT ID		
					557	POLK	18-73		S-41

THE OFFICIAL RECORD OF THIS SHEET IS THE ELECTRONIC FILE DIGITALLY SIGNED AND SEALED UNDER RULE 61G15-23.004, F.A.C.

\*  
MD/Y RPM'S PER  
INDEX 706-001  
706-1-3 88 EA  
TOTAL THIS SHEET

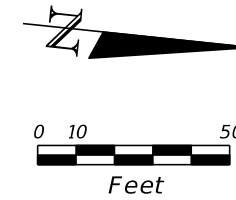

(3) OM1-3  
18" X 18"  
R6-1  
54" X 18"  
STA. 1401+20  
700-1-11 4 AS

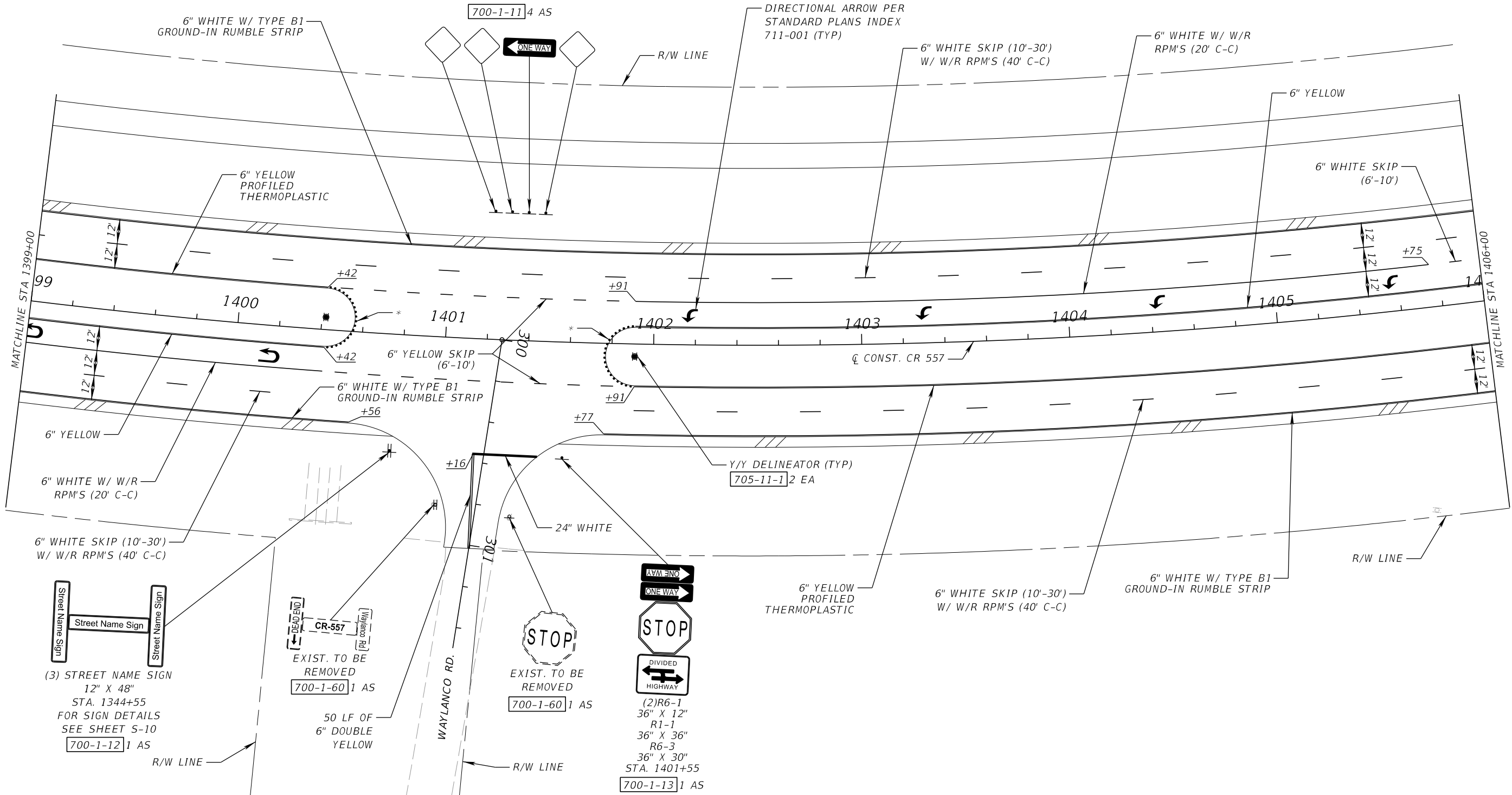

Street Name Sign  
Street Name Sign  
Street Name Sign  
(3) STREET NAME SIGN  
12" X 48"  
STA. 1344+55  
FOR SIGN DETAILS  
SEE SHEET S-10  
700-1-12 1 AS

CR-557  
EXIST. TO BE  
REMOVED  
700-1-60 1 AS  
50 LF OF  
6" DOUBLE  
YELLOW

STOP  
EXIST. TO BE  
REMOVED  
700-1-60 1 AS

ONE WAY  
ONE WAY  
STOP  
DIVIDED  
HIGHWAY  
(2)R6-1  
36" X 12"  
R1-1  
36" X 36"  
R6-3  
36" X 30"  
STA. 1401+55  
700-1-13 1 AS

REVISIONS			
DATE	DESCRIPTION	DATE	DESCRIPTION

JAMES E. BRADFORD, P.E.  
P.E. LICENSE NUMBER 68276  
DEWBERRY ENGINEERS INC.  
800 NORTH MAGNOLIA AVENUE, STE. 1000  
ORLANDO, FL 32803

POLK COUNTY PUBLIC WORKS DEPARTMENT		
ROAD NO.	COUNTY	FINANCIAL PROJECT ID
557	POLK	18-73

**SIGNING AND PAVEMENT  
MARKING PLAN**

SHEET  
NO.  
S-42

THE OFFICIAL RECORD OF THIS SHEET IS THE ELECTRONIC FILE DIGITALLY SIGNED AND SEALED UNDER RULE 61G15-23.004, F.A.C.

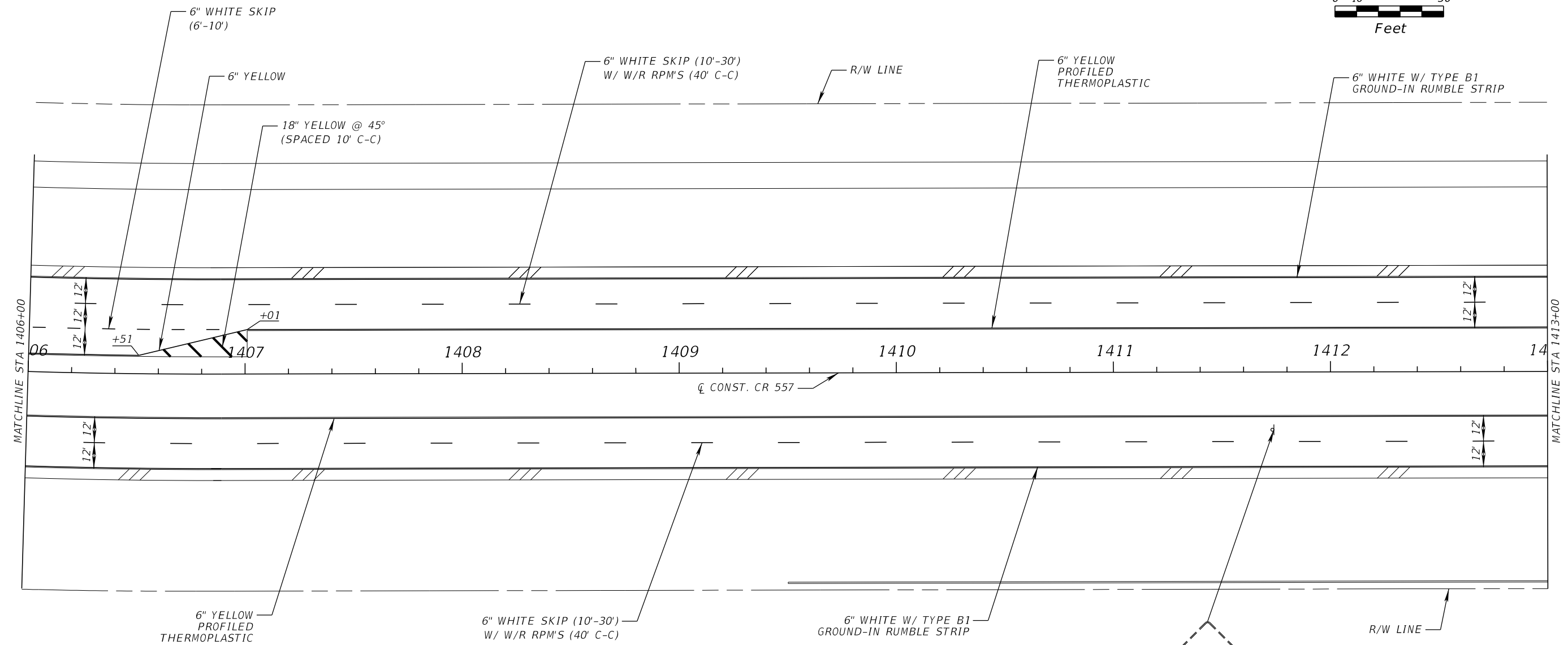
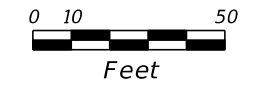

REVISIONS				JAMES E. BRADFORD, P.E. P.E. LICENSE NUMBER 68276 DEWBERRY ENGINEERS INC. 800 NORTH MAGNOLIA AVENUE, STE. 1000 ORLANDO, FL 32803	POLK COUNTY PUBLIC WORKS DEPARTMENT			SIGNING AND PAVEMENT MARKING PLAN	SHEET NO.
DATE	DESCRIPTION	DATE	DESCRIPTION		ROAD NO.	COUNTY	FINANCIAL PROJECT ID		S-43
					557	POLK	18-73		

THE OFFICIAL RECORD OF THIS SHEET IS THE ELECTRONIC FILE DIGITALLY SIGNED AND SEALED UNDER RULE 61G15-23.004, F.A.C.

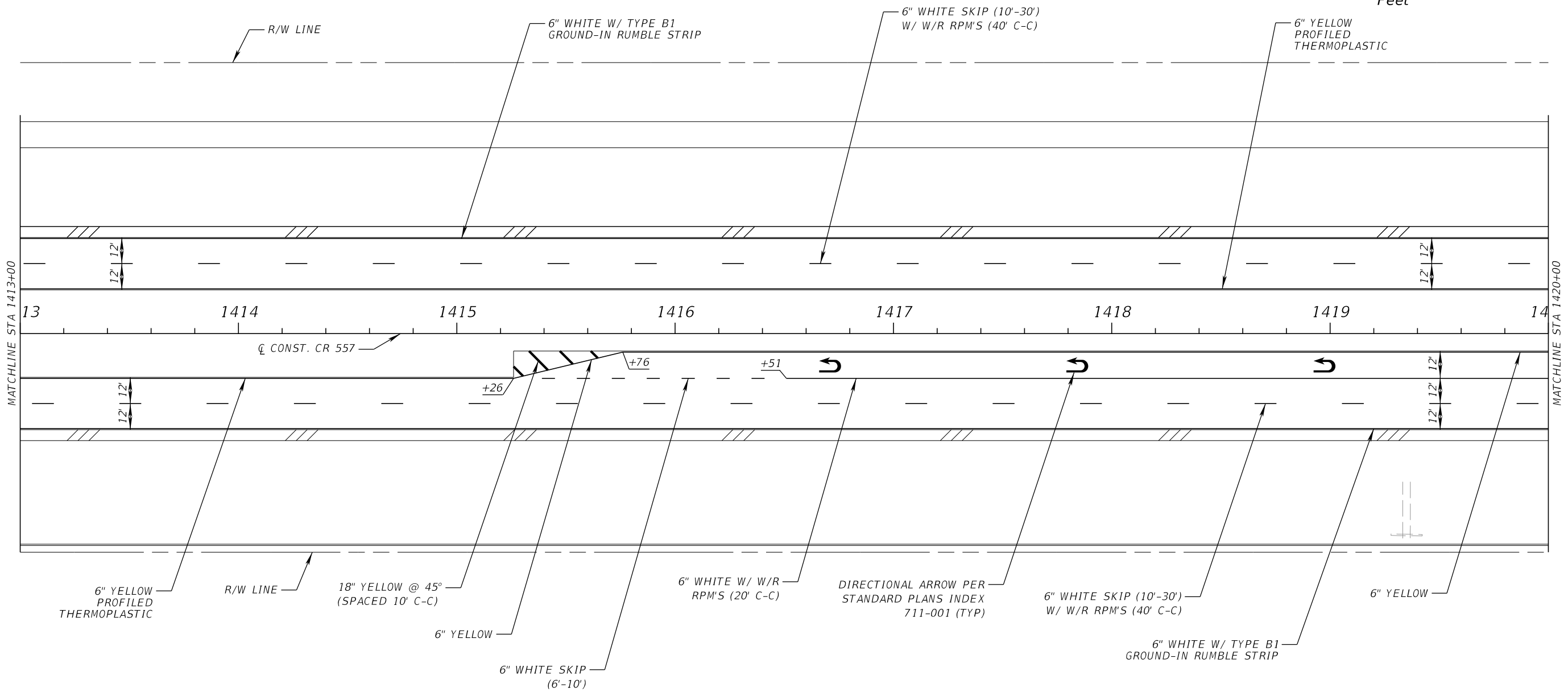
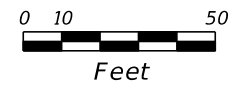

MATCHLINE STA 1413+00

MATCHLINE STA 1420+00

REVISIONS				JAMES E. BRADFORD, P.E. P.E. LICENSE NUMBER 68276 DEWBERRY ENGINEERS INC. 800 NORTH MAGNOLIA AVENUE, STE. 1000 ORLANDO, FL 32803	POLK COUNTY PUBLIC WORKS DEPARTMENT			<b>SIGNING AND PAVEMENT MARKING PLAN</b>	SHEET NO.
DATE	DESCRIPTION	DATE	DESCRIPTION		ROAD NO.	COUNTY	FINANCIAL PROJECT ID		S-44
					557	POLK	18-73		

THE OFFICIAL RECORD OF THIS SHEET IS THE ELECTRONIC FILE DIGITALLY SIGNED AND SEALED UNDER RULE 61G15-23.004, F.A.C.

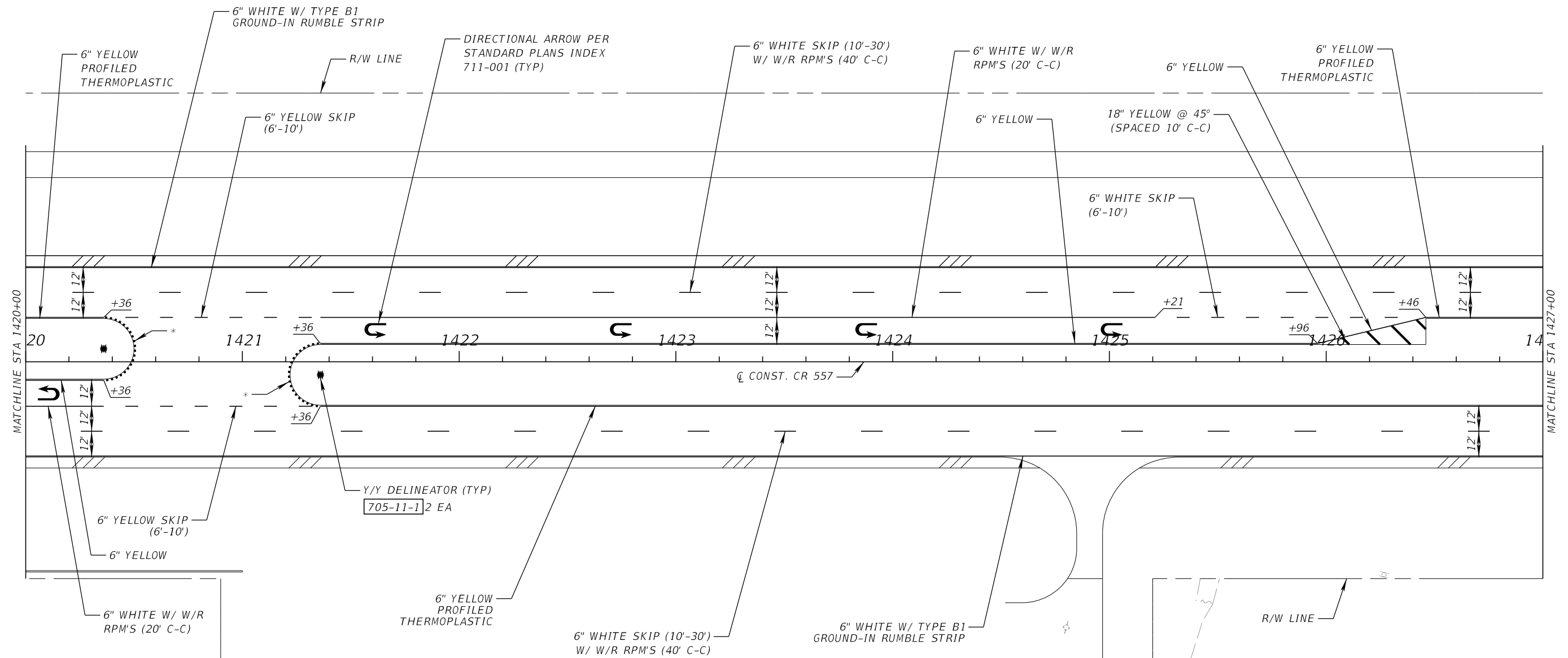
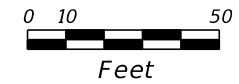

\*  
MD/Y RPM'S PER  
INDEX 706-001  
706-1-3 88 EA  
TOTAL THIS SHEET

REVISIONS			
DATE	DESCRIPTION	DATE	DESCRIPTION

JAMES E. BRADFORD, P.E.  
P.E. LICENSE NUMBER 68276  
DEWBERRY ENGINEERS INC.  
800 NORTH MAGNOLIA AVENUE, STE. 1000  
ORLANDO, FL 32803

POLK COUNTY PUBLIC WORKS DEPARTMENT		
ROAD NO.	COUNTY	FINANCIAL PROJECT ID
557	POLK	18-73

**SIGNING AND PAVEMENT  
MARKING PLAN**

SHEET  
NO.  
S-45

THE OFFICIAL RECORD OF THIS SHEET IS THE ELECTRONIC FILE DIGITALLY SIGNED AND SEALED UNDER RULE 61G15-23.004, F.A.C.

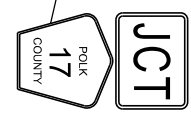
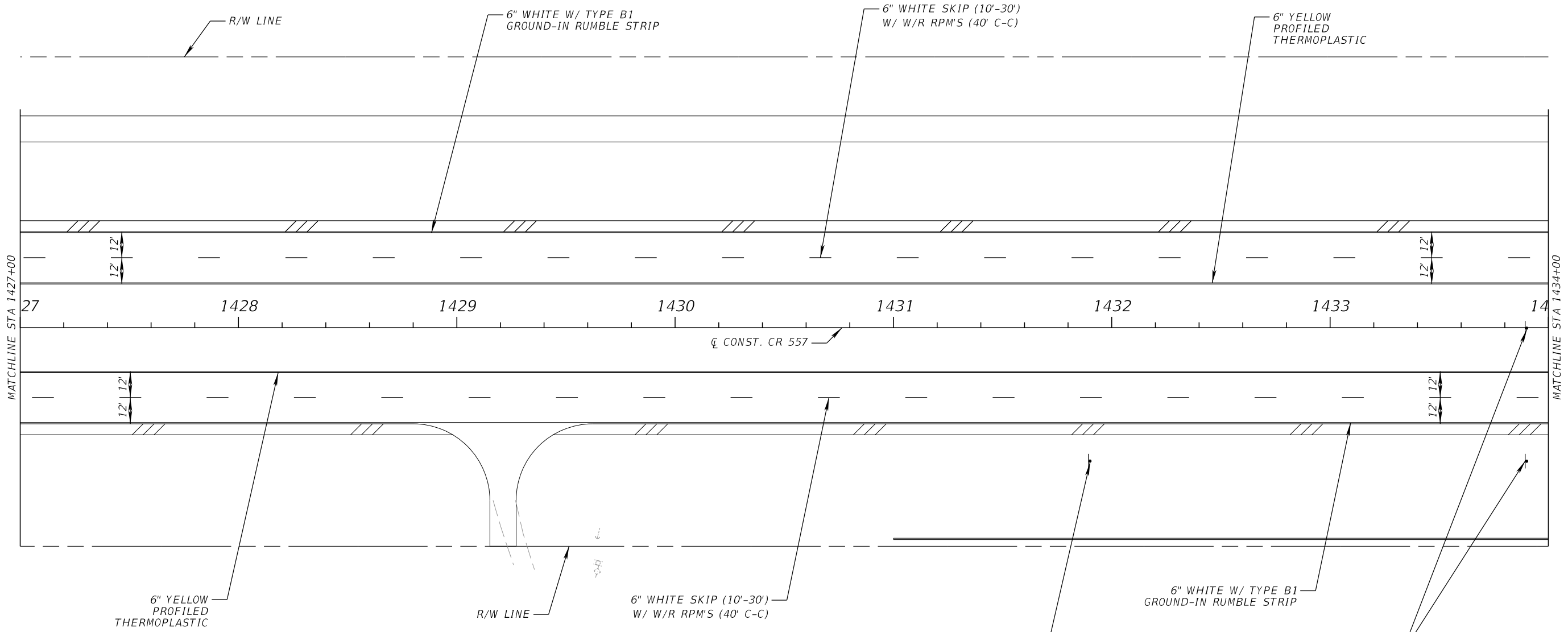
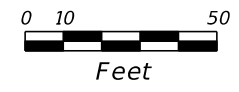

M2-1  
30" X 21"  
M1-6  
36" X 36"  
STA. 1431+90  
700-1-12 1 AS

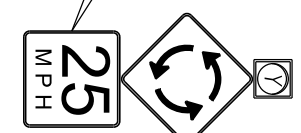

W2-6  
36" X 36"  
W13-1P  
30" X 30"  
STA. 1433+90  
700-1-12 2 AS  
700-12-21 2 AS

REVISIONS				JAMES E. BRADFORD, P.E. P.E. LICENSE NUMBER 68276 DEWBERRY ENGINEERS INC. 800 NORTH MAGNOLIA AVENUE, STE. 1000 ORLANDO, FL 32803	POLK COUNTY PUBLIC WORKS DEPARTMENT			SIGNING AND PAVEMENT MARKING PLAN	SHEET NO.
DATE	DESCRIPTION	DATE	DESCRIPTION		ROAD NO.	COUNTY	FINANCIAL PROJECT ID		S-46
					557	POLK	18-73		

THE OFFICIAL RECORD OF THIS SHEET IS THE ELECTRONIC FILE DIGITALLY SIGNED AND SEALED UNDER RULE 61G15-23.004, F.A.C.

END PAVEMENT MARKINGS W/ AUDIBLE  
AND VIBRATORY TREATMENT NB AND SB  
C CONST. CR 557  
STA. 1438+00.00

R2-1  
36" X 48"  
STA. 1438+00  
700-1-12 1 AS

M3-3  
36" X 18"  
M1-6  
36" X 36"  
STA. 1440+00  
700-1-12 1 AS

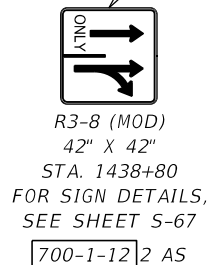
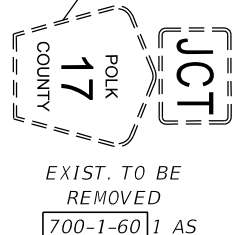
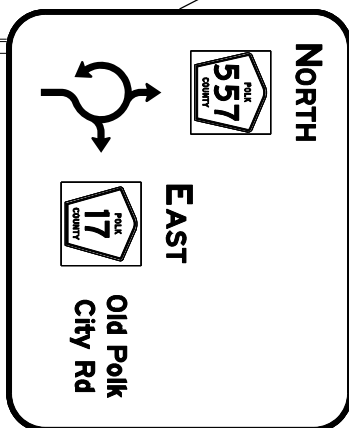
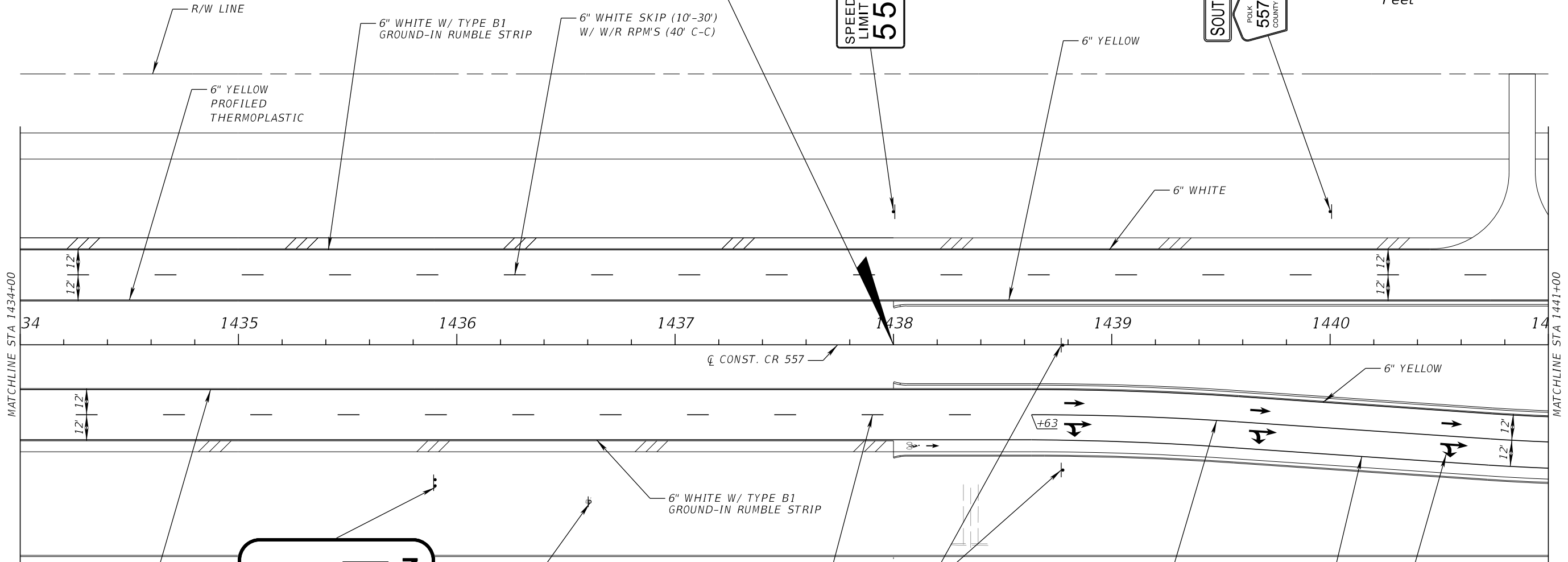
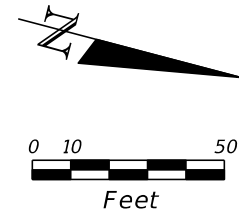

DIRECTIONAL ARROW PER  
STANDARD PLANS INDEX  
711-001 (TYP)

REVISIONS			
DATE	DESCRIPTION	DATE	DESCRIPTION

JAMES E. BRADFORD, P.E.  
P.E. LICENSE NUMBER 68276  
DEWBERRY ENGINEERS INC.  
800 NORTH MAGNOLIA AVENUE, STE. 1000  
ORLANDO, FL 32803

POLK COUNTY PUBLIC WORKS DEPARTMENT		
ROAD NO.	COUNTY	FINANCIAL PROJECT ID
557	POLK	18-73

**SIGNING AND PAVEMENT  
MARKING PLAN**

SHEET  
NO.  
S-47

THE OFFICIAL RECORD OF THIS SHEET IS THE ELECTRONIC FILE DIGITALLY SIGNED AND SEALED UNDER RULE 61G15-23.004, F.A.C.





GM-6  
SIGN 106  
11'-0" X 9'-0"  
STA. 1453+90  
FOR SIGN DETAILS  
SEE SHEET S-67  
700-2-15] 1 AS

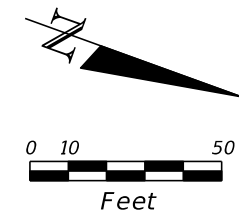

R3-8 (MOD)  
42" X 42"  
STA. 1452+09  
FOR SIGN DETAILS,  
SEE SHEET S-67  
700-1-12] 2 AS

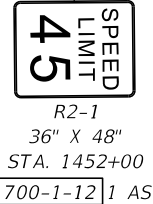
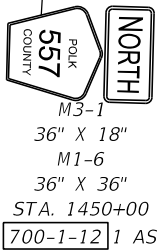
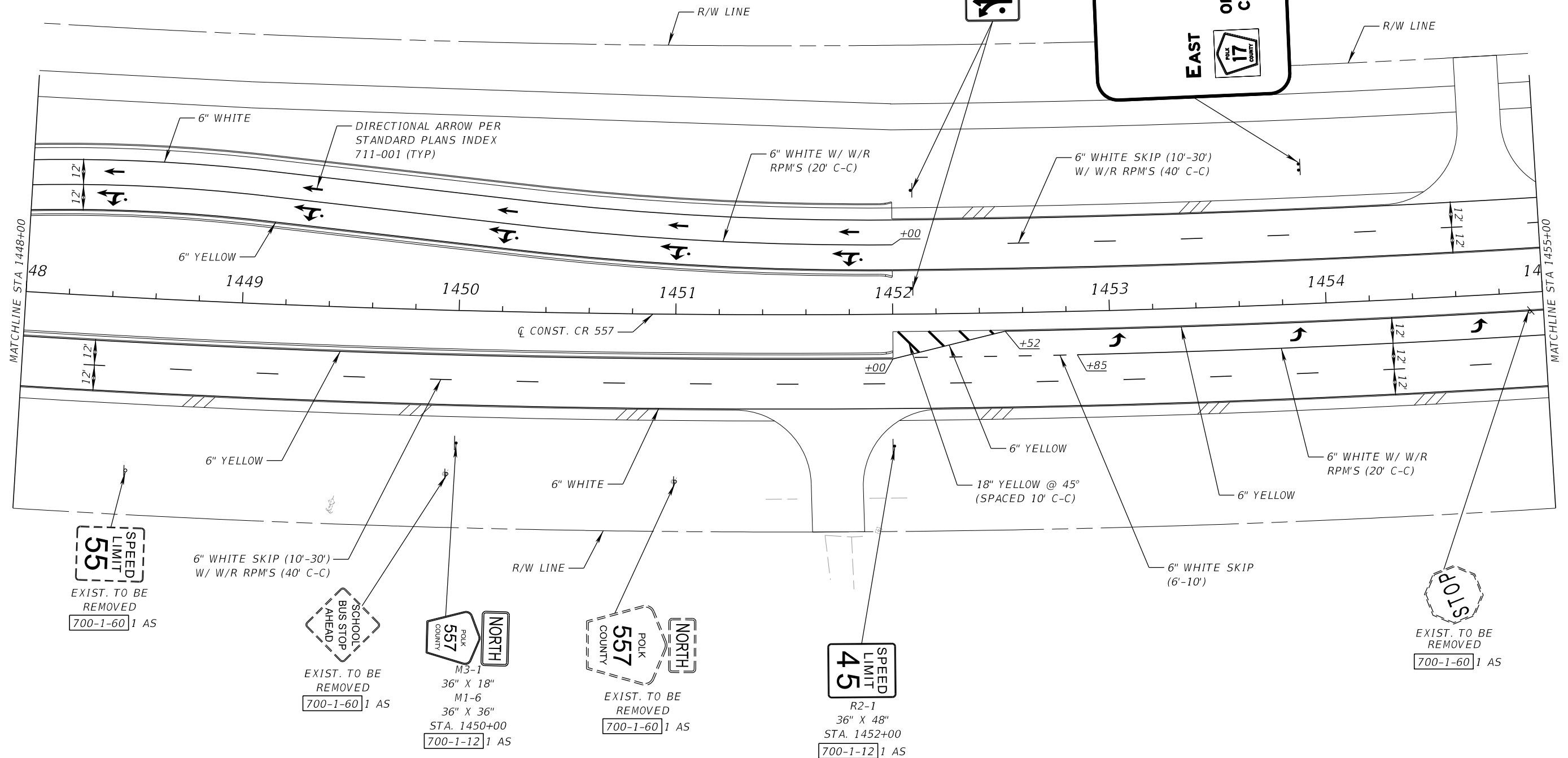
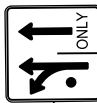
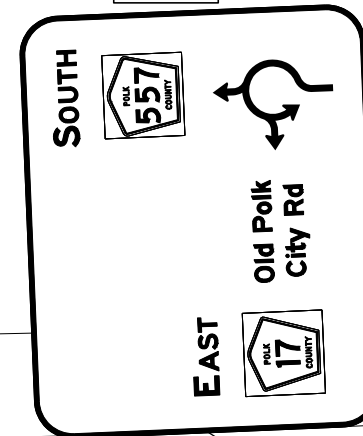

REVISIONS				JAMES E. BRADFORD, P.E. P.E. LICENSE NUMBER 68276 DEWBERRY ENGINEERS INC. 800 NORTH MAGNOLIA AVENUE, STE. 1000 ORLANDO, FL 32803	POLK COUNTY PUBLIC WORKS DEPARTMENT			SIGNING AND PAVEMENT MARKING PLAN	SHEET NO.
DATE	DESCRIPTION	DATE	DESCRIPTION		ROAD NO.	COUNTY	FINANCIAL PROJECT ID		
						557	POLK		18-73

THE OFFICIAL RECORD OF THIS SHEET IS THE ELECTRONIC FILE DIGITALLY SIGNED AND SEALED UNDER RULE 61G15-23.004, F.A.C.

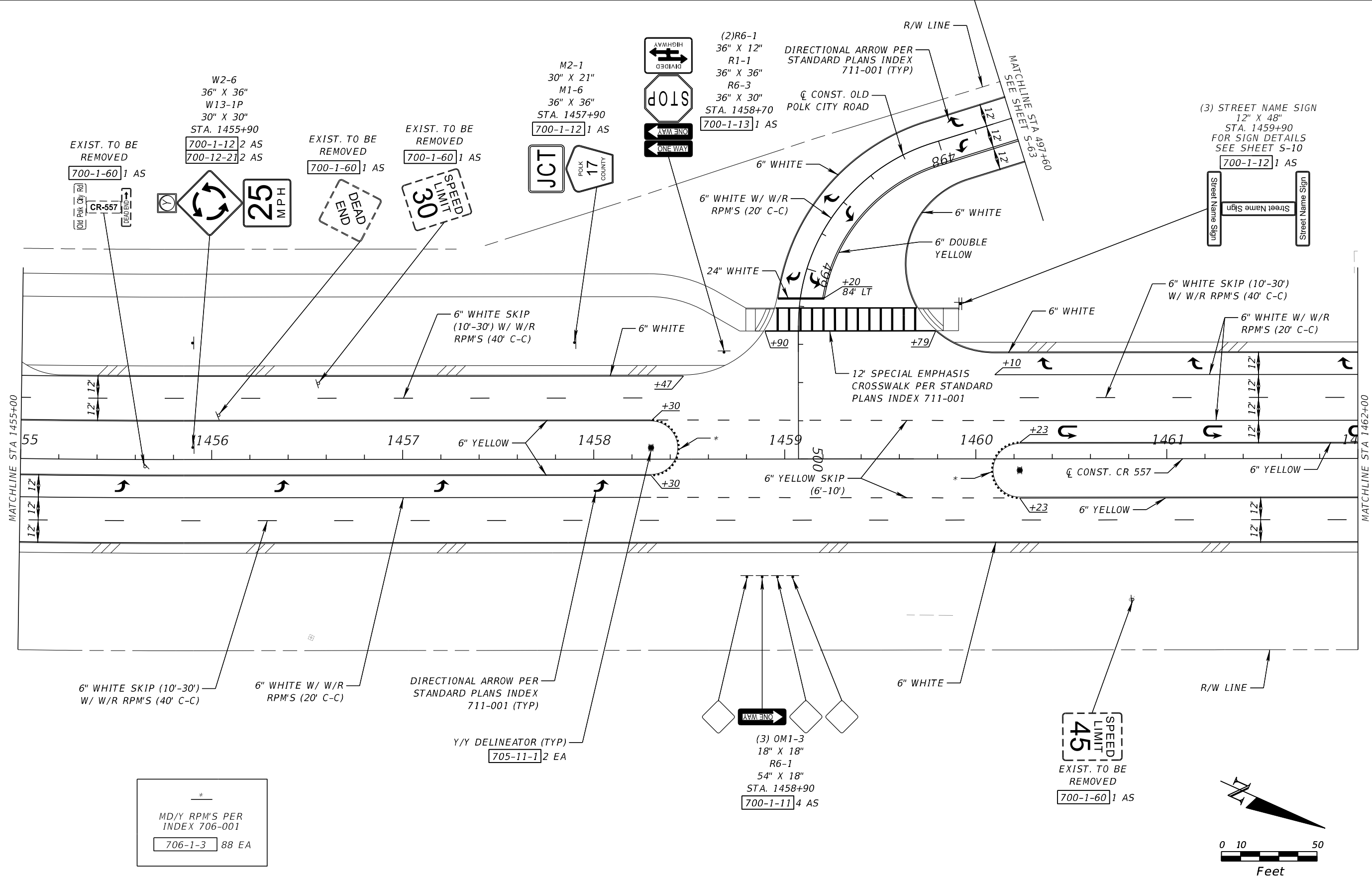

W2-6  
36" X 36"  
W13-1P  
30" X 30"  
STA. 1455+90  
700-1-12 2 AS  
700-12-21 2 AS

EXIST. TO BE REMOVED  
700-1-60 1 AS

EXIST. TO BE REMOVED  
700-1-60 1 AS

EXIST. TO BE REMOVED  
700-1-60 1 AS

M2-1  
30" X 21"  
M1-6  
36" X 36"  
STA. 1457+90  
700-1-12 1 AS

(2)R6-1  
36" X 12"  
R1-1  
36" X 36"  
R6-3  
36" X 30"  
STA. 1458+70  
700-1-13 1 AS

(3) STREET NAME SIGN  
12" X 48"  
STA. 1459+90  
FOR SIGN DETAILS  
SEE SHEET S-10  
700-1-12 1 AS

\*  
MD/Y RPM'S PER  
INDEX 706-001  
706-1-3 88 EA

REVISIONS			
DATE	DESCRIPTION	DATE	DESCRIPTION

JAMES E. BRADFORD, P.E.  
P.E. LICENSE NUMBER 68276  
DEWBERRY ENGINEERS INC.  
800 NORTH MAGNOLIA AVENUE, STE. 1000  
ORLANDO, FL 32803

POLK COUNTY PUBLIC WORKS DEPARTMENT		
ROAD NO.	COUNTY	FINANCIAL PROJECT ID
557	POLK	18-73

**SIGNING AND PAVEMENT  
MARKING PLAN**

SHEET NO.  
S-50

THE OFFICIAL RECORD OF THIS SHEET IS THE ELECTRONIC FILE DIGITALLY SIGNED AND SEALED UNDER RULE 61G15-23.004, F.A.C.

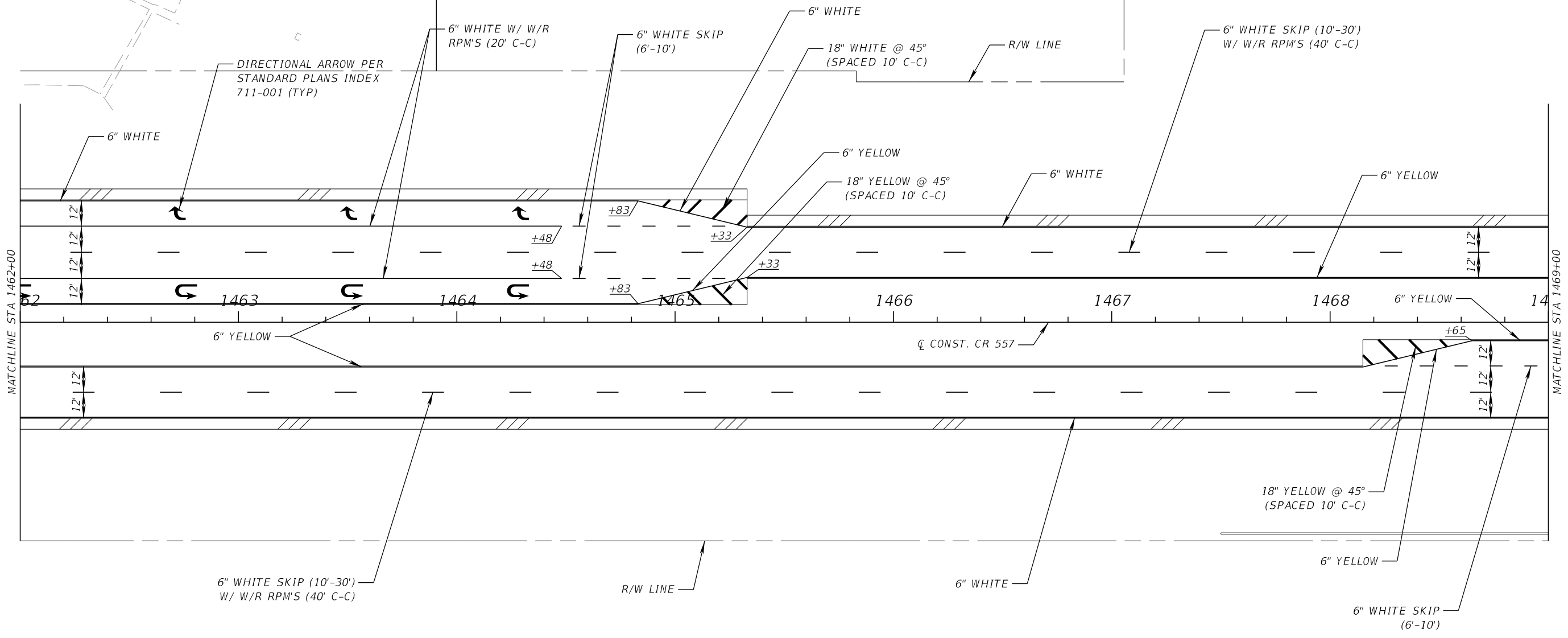
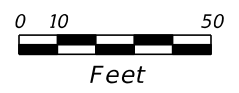

MATCHLINE STA 1462+00

MATCHLINE STA 1469+00

REVISIONS			
DATE	DESCRIPTION	DATE	DESCRIPTION

JAMES E. BRADFORD, P.E.  
 P.E. LICENSE NUMBER 68276  
 DEWBERRY ENGINEERS INC.  
 800 NORTH MAGNOLIA AVENUE, STE. 1000  
 ORLANDO, FL 32803

POLK COUNTY PUBLIC WORKS DEPARTMENT		
ROAD NO.	COUNTY	FINANCIAL PROJECT ID
557	POLK	18-73

**SIGNING AND PAVEMENT  
MARKING PLAN**

SHEET NO.  
S-51

THE OFFICIAL RECORD OF THIS SHEET IS THE ELECTRONIC FILE DIGITALLY SIGNED AND SEALED UNDER RULE 61G15-23.004, F.A.C.

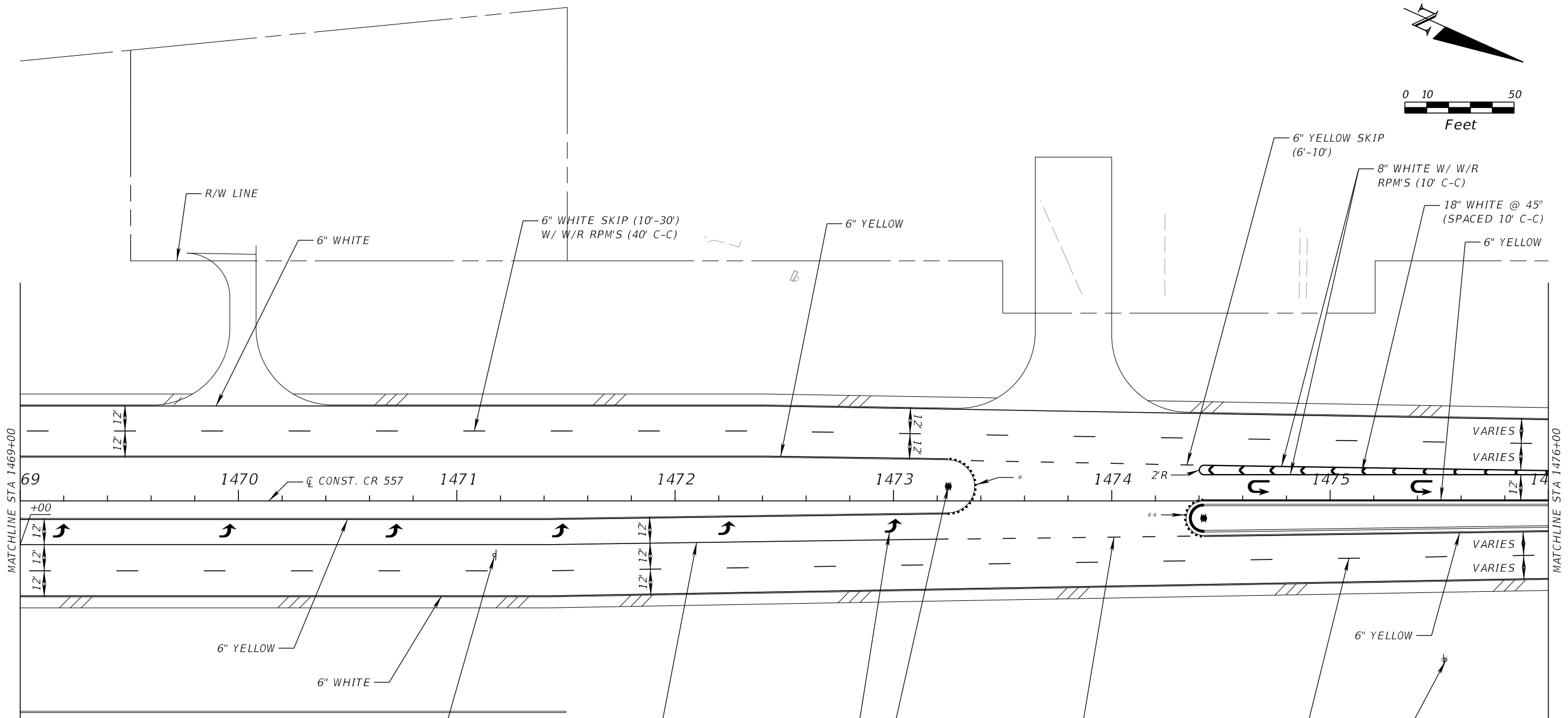
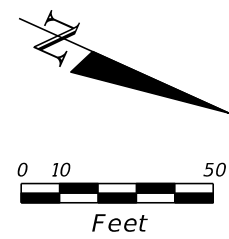

MATCHLINE STA 1469+00

MATCHLINE STA 1476+00

**SPEED LIMIT 55**  
EXIST. TO BE REMOVED  
700-1-60 1 AS

Y/Y DELINEATOR (TYP)  
705-11-1 2 EA

\*  
MD/Y RPM'S PER INDEX 706-001  
706-1-3 36 EA

\*\*  
YELLOW ISLAND NOSE PAINT W/ MD/Y RPM'S PER INDEX 706-001  
710-12-290 14.3 SF  
706-1-3 24 EA

**ROAD 145**  
EXIST. TO BE REMOVED  
700-1-60 1 AS

REVISIONS				JAMES E. BRADFORD, P.E. P.E. LICENSE NUMBER 68276 DEWBERRY ENGINEERS INC. 800 NORTH MAGNOLIA AVENUE, STE. 1000 ORLANDO, FL 32803	POLK COUNTY PUBLIC WORKS DEPARTMENT			<b>SIGNING AND PAVEMENT MARKING PLAN</b>	SHEET NO.
DATE	DESCRIPTION	DATE	DESCRIPTION		ROAD NO.	COUNTY	FINANCIAL PROJECT ID		
						557	POLK		18-73

THE OFFICIAL RECORD OF THIS SHEET IS THE ELECTRONIC FILE DIGITALLY SIGNED AND SEALED UNDER RULE 61G15-23.004, F.A.C.

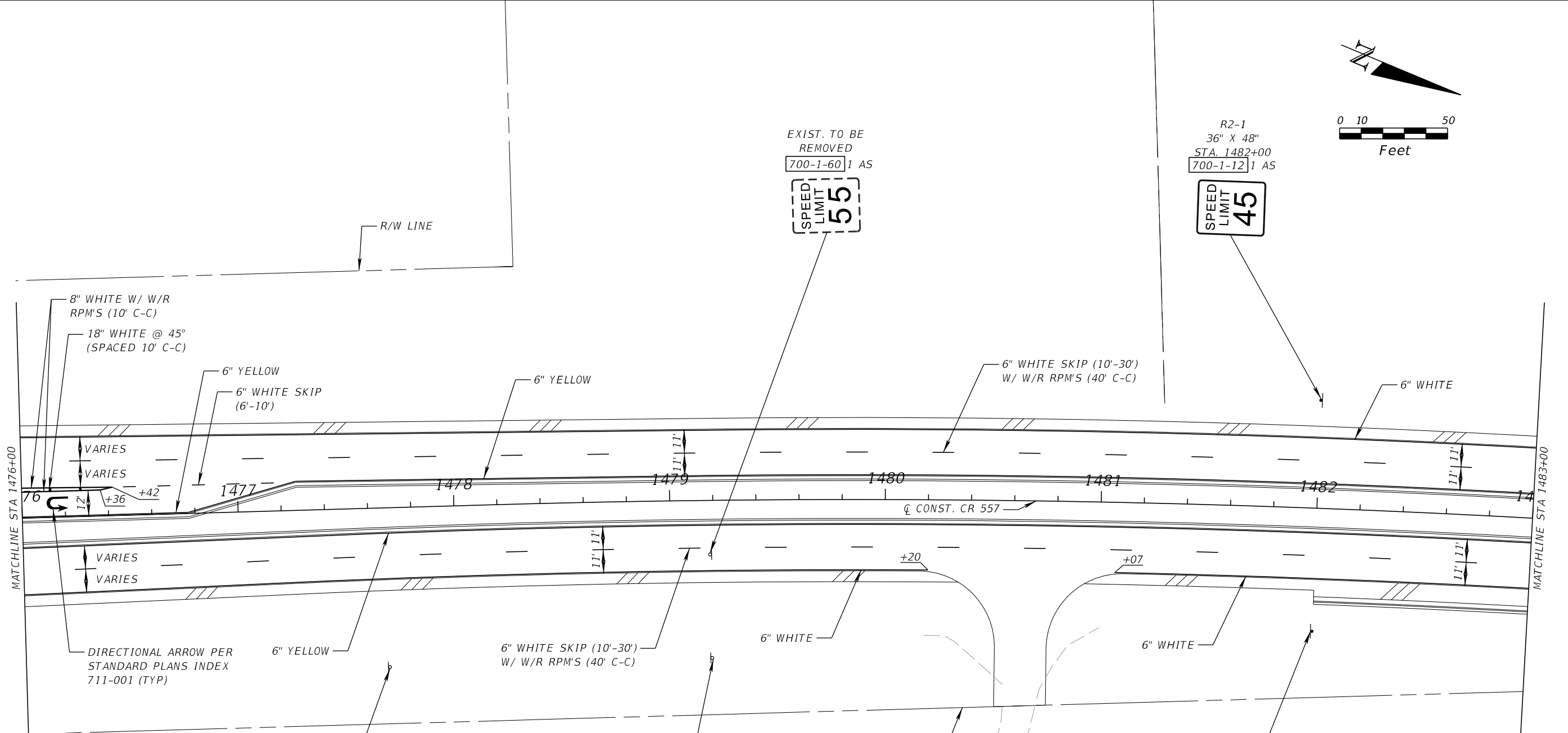
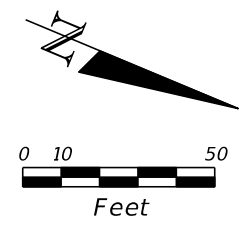

EXIST. TO BE REMOVED  
700-1-60 1 AS  
SPEED LIMIT 55

R2-1  
36" X 48"  
STA. 1482+00  
700-1-12 1 AS  
SPEED LIMIT 45

EXIST. TO BE REMOVED  
700-1-60 1 AS

EXIST. TO BE REMOVED  
700-1-60 1 AS  
SPEED LIMIT 45

R2-1  
36" X 48"  
STA. 1482+00  
700-1-12 1 AS  
SPEED LIMIT 45

REVISIONS			
DATE	DESCRIPTION	DATE	DESCRIPTION

JAMES E. BRADFORD, P.E.  
P.E. LICENSE NUMBER 68276  
DEWBERRY ENGINEERS INC.  
800 NORTH MAGNOLIA AVENUE, STE. 1000  
ORLANDO, FL 32803

POLK COUNTY PUBLIC WORKS DEPARTMENT		
ROAD NO.	COUNTY	FINANCIAL PROJECT ID
557	POLK	18-73

**SIGNING AND PAVEMENT  
MARKING PLAN**

SHEET NO.  
S-53

THE OFFICIAL RECORD OF THIS SHEET IS THE ELECTRONIC FILE DIGITALLY SIGNED AND SEALED UNDER RULE 61G15-23.004, F.A.C.

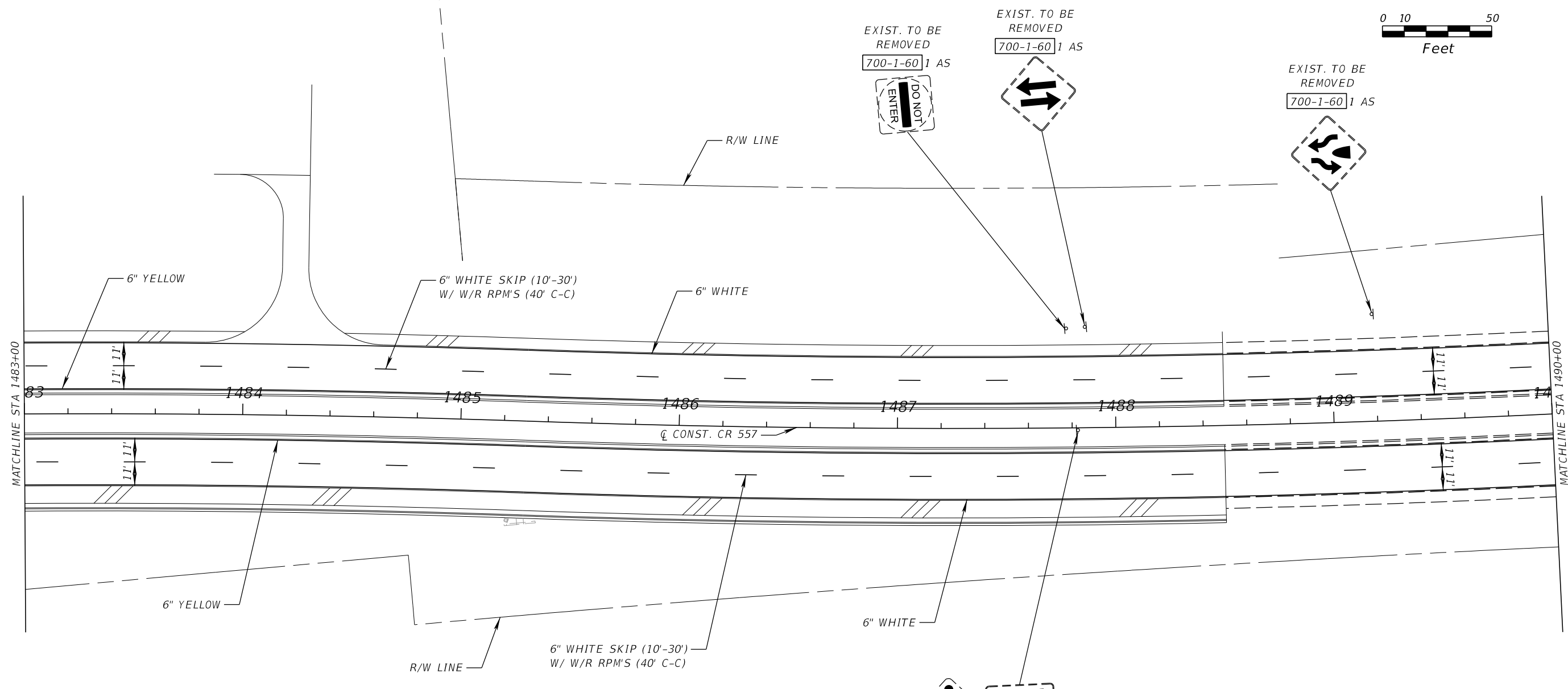
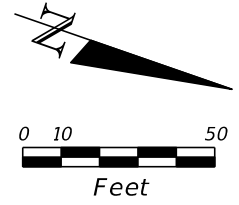

EXIST. TO BE REMOVED  
700-1-60 1 AS

EXIST. TO BE REMOVED  
700-1-60 1 AS

EXIST. TO BE REMOVED  
700-1-60 1 AS

EXIST. TO BE REMOVED  
700-1-60 1 AS

REVISIONS				JAMES E. BRADFORD, P.E. P.E. LICENSE NUMBER 68276 DEWBERRY ENGINEERS INC. 800 NORTH MAGNOLIA AVENUE, STE. 1000 ORLANDO, FL 32803	POLK COUNTY PUBLIC WORKS DEPARTMENT			<b>SIGNING AND PAVEMENT MARKING PLAN</b>	SHEET NO.
DATE	DESCRIPTION	DATE	DESCRIPTION		ROAD NO.	COUNTY	FINANCIAL PROJECT ID		
						557	POLK		18-73

THE OFFICIAL RECORD OF THIS SHEET IS THE ELECTRONIC FILE DIGITALLY SIGNED AND SEALED UNDER RULE 61G15-23.004, F.A.C.

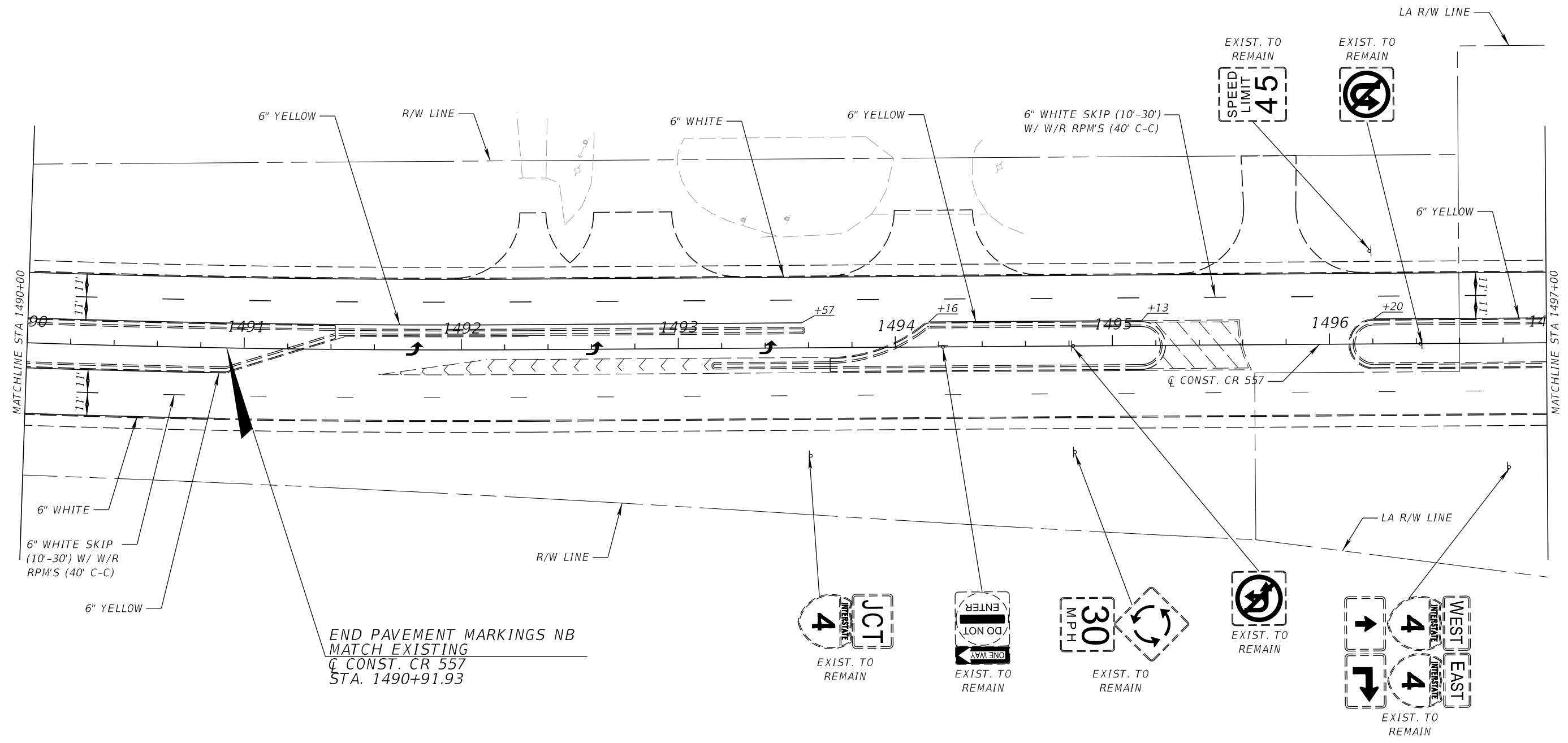
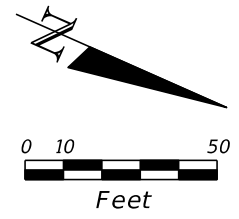

END PAVEMENT MARKINGS NB  
MATCH EXISTING  
C CONST. CR 557  
STA. 1490+91.93

REVISIONS				JAMES E. BRADFORD, P.E. P.E. LICENSE NUMBER 68276 DEWBERRY ENGINEERS INC. 800 NORTH MAGNOLIA AVENUE, STE. 1000 ORLANDO, FL 32803	POLK COUNTY PUBLIC WORKS DEPARTMENT			SIGNING AND PAVEMENT MARKING PLAN	SHEET NO.
DATE	DESCRIPTION	DATE	DESCRIPTION		ROAD NO.	COUNTY	FINANCIAL PROJECT ID		
					557	POLK	18-73		S-55

THE OFFICIAL RECORD OF THIS SHEET IS THE ELECTRONIC FILE DIGITALLY SIGNED AND SEALED UNDER RULE 61G15-23.004, F.A.C.

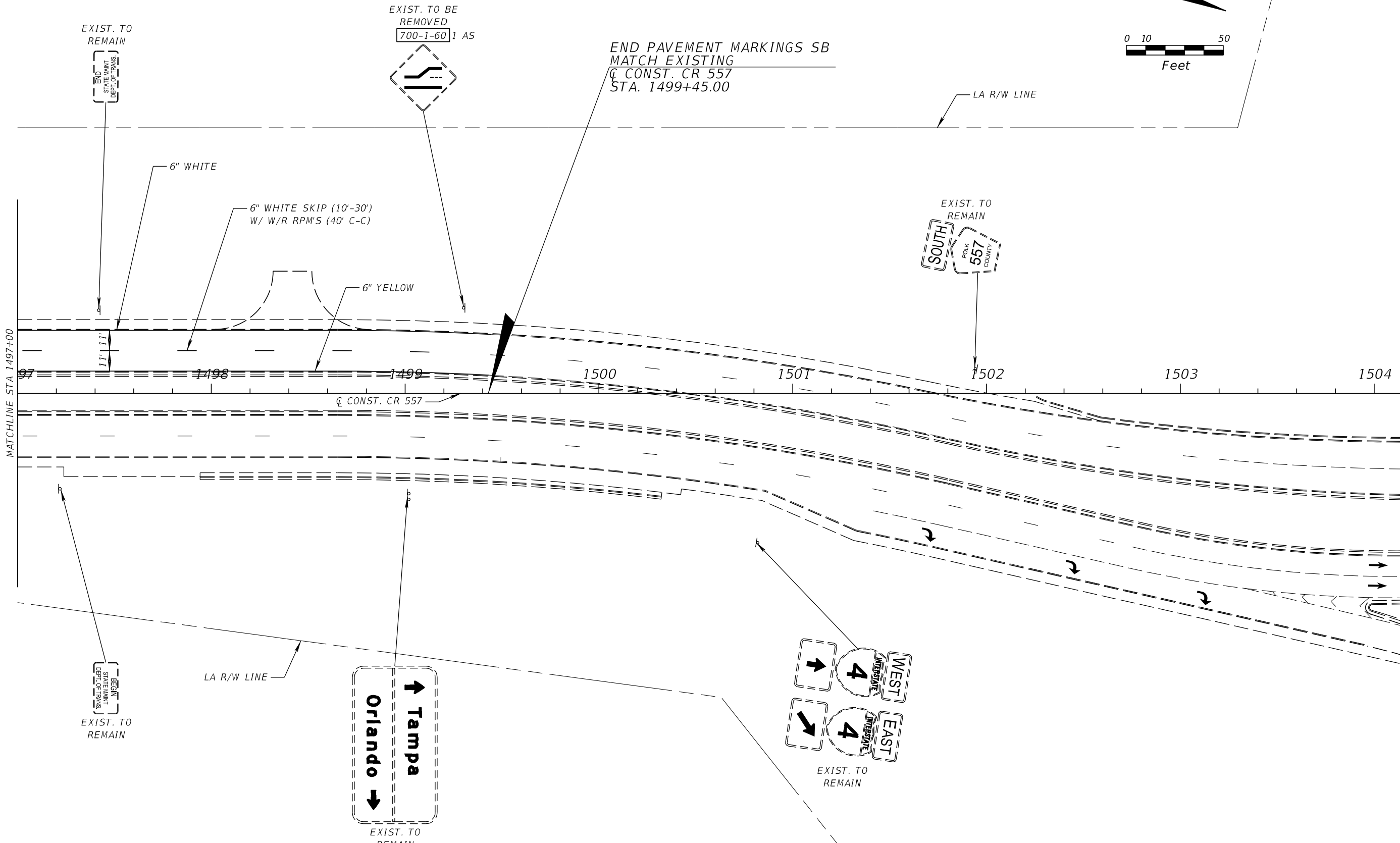
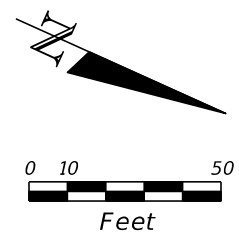

REVISIONS			
DATE	DESCRIPTION	DATE	DESCRIPTION

JAMES E. BRADFORD, P.E.  
 P.E. LICENSE NUMBER 68276  
 DEWBERRY ENGINEERS INC.  
 800 NORTH MAGNOLIA AVENUE, STE. 1000  
 ORLANDO, FL 32803

POLK COUNTY PUBLIC WORKS DEPARTMENT		
ROAD NO.	COUNTY	FINANCIAL PROJECT ID
557	POLK	18-73

**SIGNING AND PAVEMENT  
MARKING PLAN**

SHEET NO.  
S-56

THE OFFICIAL RECORD OF THIS SHEET IS THE ELECTRONIC FILE DIGITALLY SIGNED AND SEALED UNDER RULE 61G15-23.004, F.A.C.



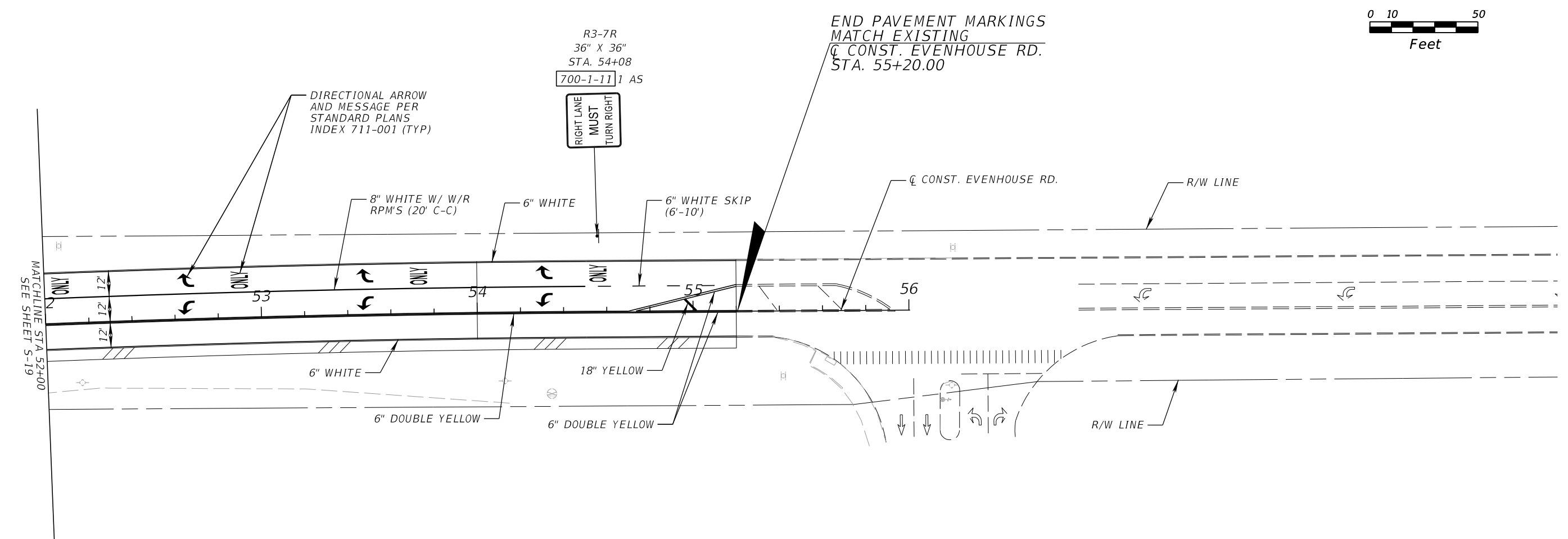
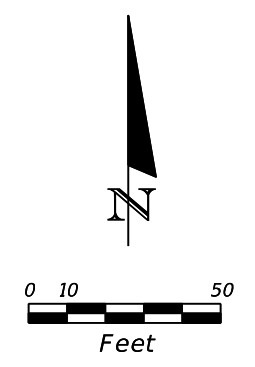

MATCHLINE STA 52+00  
SEE SHEET S-19

END PAVEMENT MARKINGS  
MATCH EXISTING  
CONST. EVENHOUSE RD.  
STA. 55+20.00

R3-7R  
36" X 36"  
STA. 54+08  
700-1-11 1 AS

RIGHT LANE  
MUST  
TURN RIGHT

DIRECTIONAL ARROW  
AND MESSAGE PER  
STANDARD PLANS  
INDEX 711-001 (TYP)

8" WHITE W/ W/R  
RPM'S (20' C-C)

6" WHITE

6" WHITE SKIP  
(6'-10')

CONST. EVENHOUSE RD.

R/W LINE

6" WHITE

18" YELLOW

6" DOUBLE YELLOW

6" DOUBLE YELLOW

R/W LINE

REVISIONS

DATE	DESCRIPTION	DATE	DESCRIPTION

JAMES E. BRADFORD, P.E.  
P.E. LICENSE NUMBER 68276  
DEWBERRY ENGINEERS INC.  
800 NORTH MAGNOLIA AVENUE, STE. 1000  
ORLANDO, FL 32803

POLK COUNTY PUBLIC WORKS DEPARTMENT		
ROAD NO.	COUNTY	FINANCIAL PROJECT ID
557	POLK	18-73

**SIGNING AND PAVEMENT  
MARKING PLAN**

SHEET  
NO.  
**S-57**

THE OFFICIAL RECORD OF THIS SHEET IS THE ELECTRONIC FILE DIGITALLY SIGNED AND SEALED UNDER RULE 61G15-23.004, F.A.C.

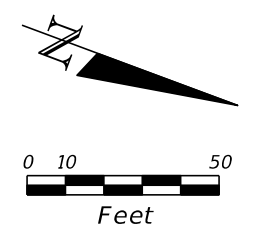

EXIST. TO BE  
REMOVED  
700-1-60 1 AS

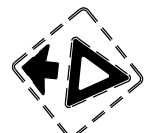

(3) OM4-3  
18" X 18"  
STA. 200+15  
700-1-11 3 AS



R/W LINE

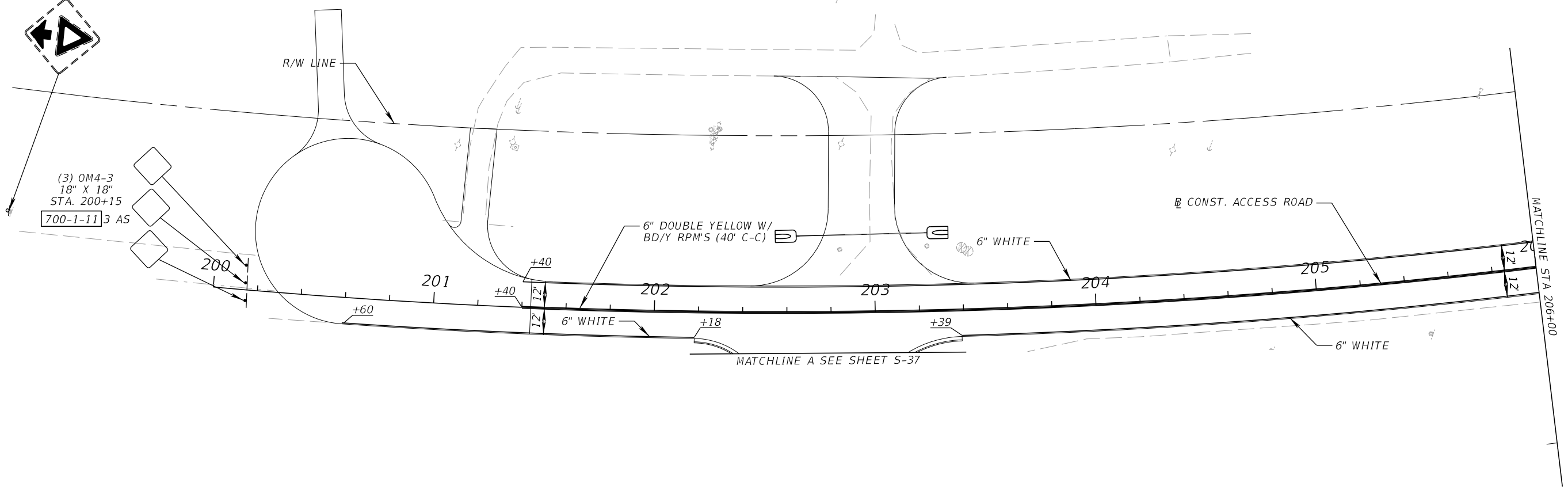

MATCHLINE STA 206+00

REVISIONS				JAMES E. BRADFORD, P.E. P.E. LICENSE NUMBER 68276 DEWBERRY ENGINEERS INC. 800 NORTH MAGNOLIA AVENUE, STE. 1000 ORLANDO, FL 32803	POLK COUNTY PUBLIC WORKS DEPARTMENT			SIGNING AND PAVEMENT MARKING PLAN	SHEET NO.  S-58
DATE	DESCRIPTION	DATE	DESCRIPTION		ROAD NO.	COUNTY	FINANCIAL PROJECT ID		
					557	POLK	18-73		

THE OFFICIAL RECORD OF THIS SHEET IS THE ELECTRONIC FILE DIGITALLY SIGNED AND SEALED UNDER RULE 61G15-23.004, F.A.C.

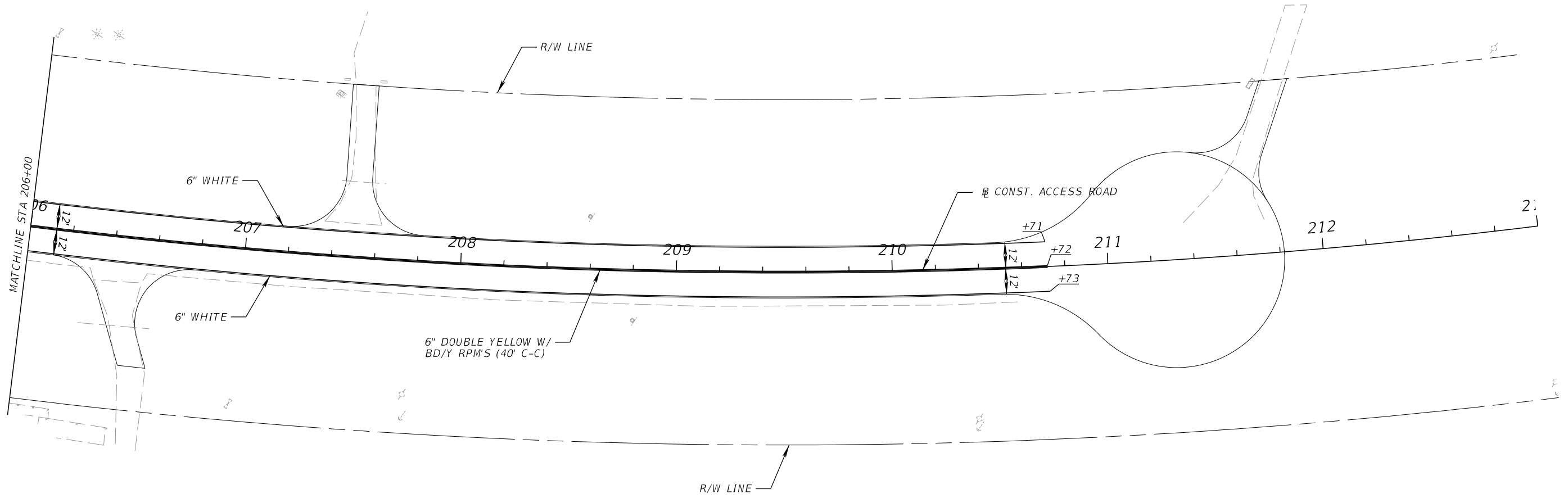
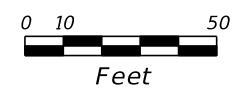
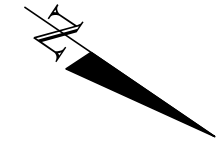

REVISIONS				JAMES E. BRADFORD, P.E. P.E. LICENSE NUMBER 68276 DEWBERRY ENGINEERS INC. 800 NORTH MAGNOLIA AVENUE, STE. 1000 ORLANDO, FL 32803	POLK COUNTY PUBLIC WORKS DEPARTMENT			<b>SIGNING AND PAVEMENT            MARKING PLAN</b>	SHEET NO.
DATE	DESCRIPTION	DATE	DESCRIPTION		ROAD NO.	COUNTY	FINANCIAL PROJECT ID		
						557	POLK		18-73

THE OFFICIAL RECORD OF THIS SHEET IS THE ELECTRONIC FILE DIGITALLY SIGNED AND SEALED UNDER RULE 61G15-23.004, F.A.C.

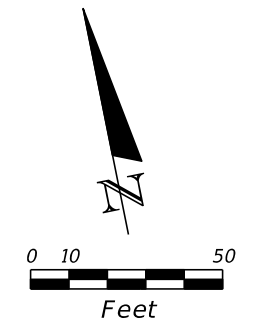

END PAVEMENT MARKINGS  
MATCH EXISTING  
C CONST. CR 557A  
STA. 600+20.00

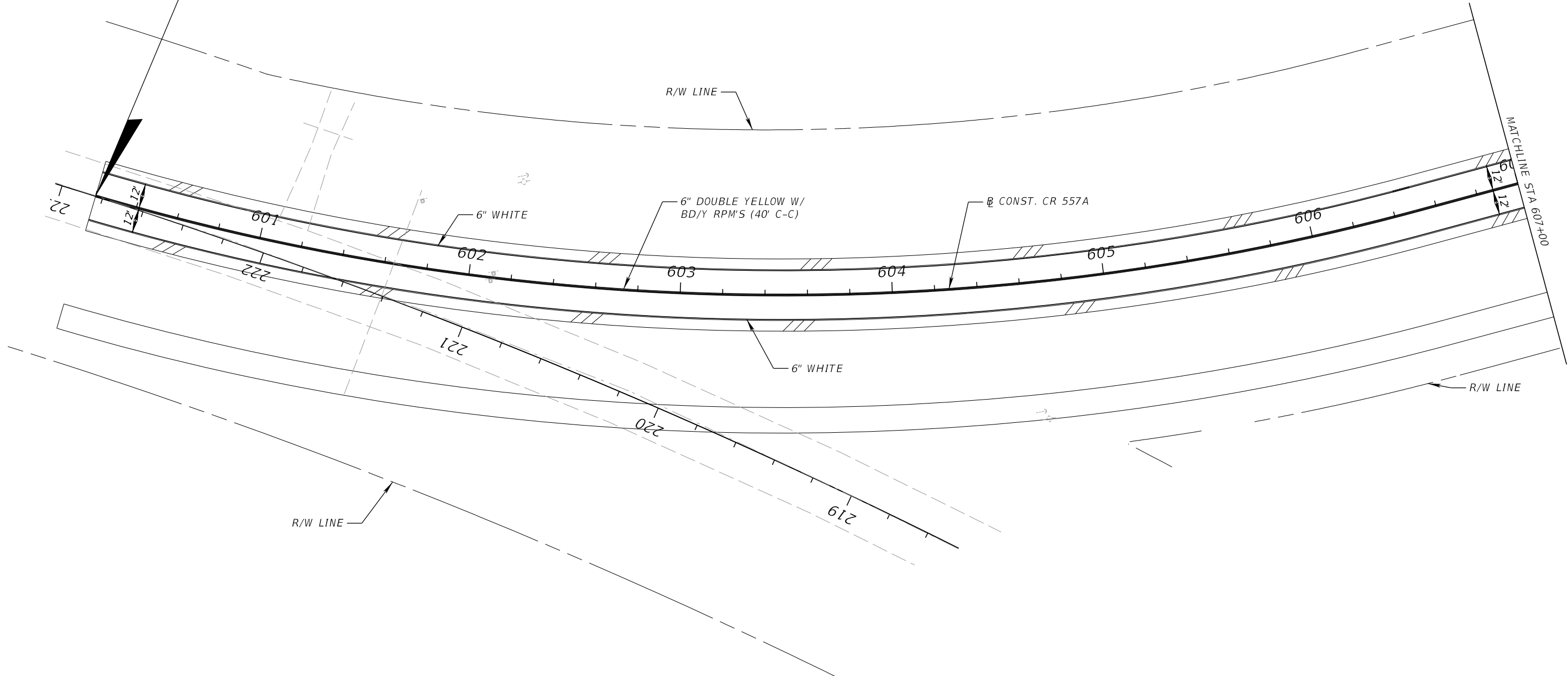

MATCHLINE STA 607+00

REVISIONS				JAMES E. BRADFORD, P.E. P.E. LICENSE NUMBER 68276 DEWBERRY ENGINEERS INC. 800 NORTH MAGNOLIA AVENUE, STE. 1000 ORLANDO, FL 32803	POLK COUNTY PUBLIC WORKS DEPARTMENT			<b>SIGNING AND PAVEMENT MARKING PLAN</b>	SHEET NO.  S-60
DATE	DESCRIPTION	DATE	DESCRIPTION		ROAD NO.	COUNTY	FINANCIAL PROJECT ID		
					557	POLK	18-73		

THE OFFICIAL RECORD OF THIS SHEET IS THE ELECTRONIC FILE DIGITALLY SIGNED AND SEALED UNDER RULE 61G15-23.004, F.A.C.

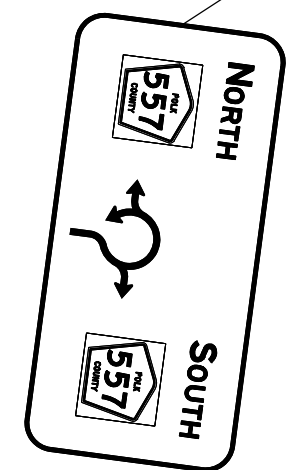
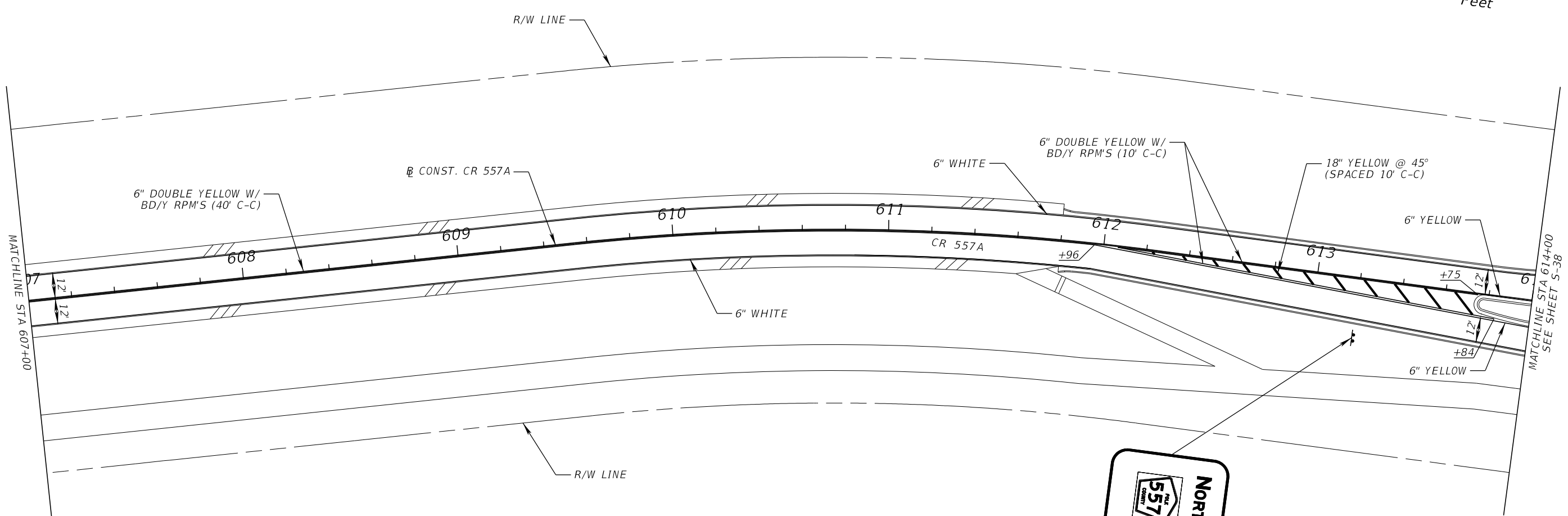
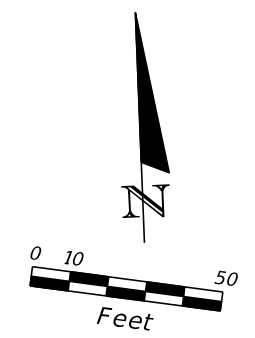

GM-3  
SIGN 103  
11'-6" X 5'-6"  
STA. 613+20  
FOR SIGN DETAILS  
SEE SHEET S-66  
700-2-15 1 AS

REVISIONS				JAMES E. BRADFORD, P.E. P.E. LICENSE NUMBER 68276 DEWBERRY ENGINEERS INC. 800 NORTH MAGNOLIA AVENUE, STE. 1000 ORLANDO, FL 32803	POLK COUNTY PUBLIC WORKS DEPARTMENT			<b>SIGNING AND PAVEMENT MARKING PLAN</b>	SHEET NO.
DATE	DESCRIPTION	DATE	DESCRIPTION		ROAD NO.	COUNTY	FINANCIAL PROJECT ID		
						557	POLK		18-73

THE OFFICIAL RECORD OF THIS SHEET IS THE ELECTRONIC FILE DIGITALLY SIGNED AND SEALED UNDER RULE 61G15-23.004, F.A.C.

GM-4  
SIGN 104  
11'-6" X 5'-6"  
STA. 703+00  
FOR SIGN DETAILS  
SEE SHEET S-66  
700-2-15 I AS

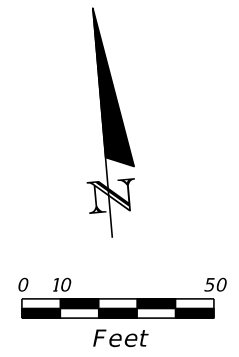
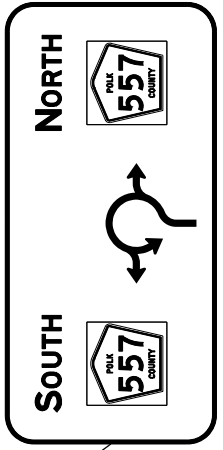

END PAVEMENT MARKINGS  
MATCH EXISTING  
CONST. POLK CITY ROAD  
STA. 703+85.00

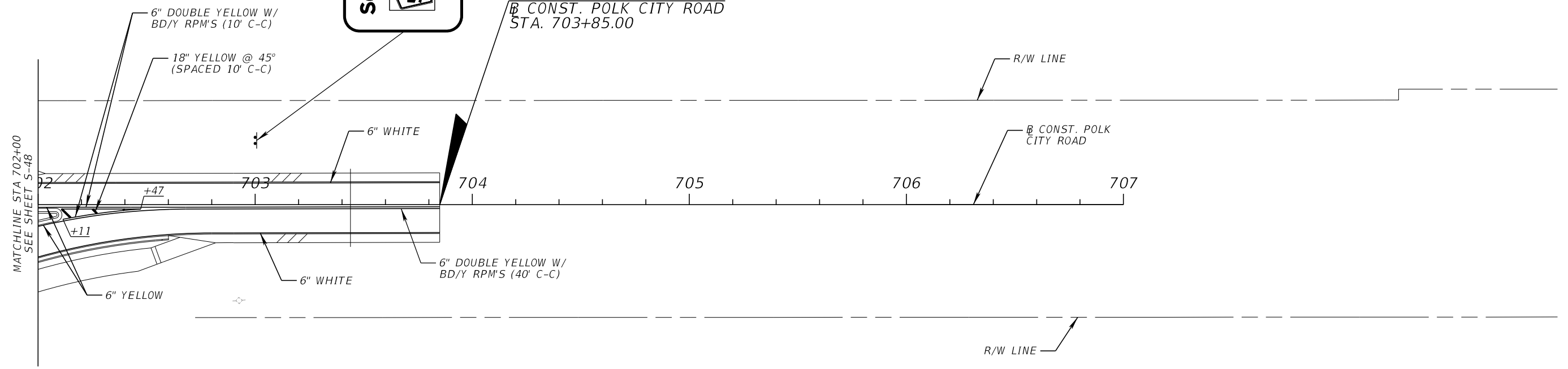

MATCHLINE STA 702+00  
SEE SHEET S-48

REVISIONS				JAMES E. BRADFORD, P.E. P.E. LICENSE NUMBER 68276 DEWBERRY ENGINEERS INC. 800 NORTH MAGNOLIA AVENUE, STE. 1000 ORLANDO, FL 32803	POLK COUNTY PUBLIC WORKS DEPARTMENT			SIGNING AND PAVEMENT MARKING PLAN	SHEET NO.
DATE	DESCRIPTION	DATE	DESCRIPTION		ROAD NO.	COUNTY	FINANCIAL PROJECT ID		S-62
					557	POLK	18-73		

THE OFFICIAL RECORD OF THIS SHEET IS THE ELECTRONIC FILE DIGITALLY SIGNED AND SEALED UNDER RULE 61G15-23.004, F.A.C.

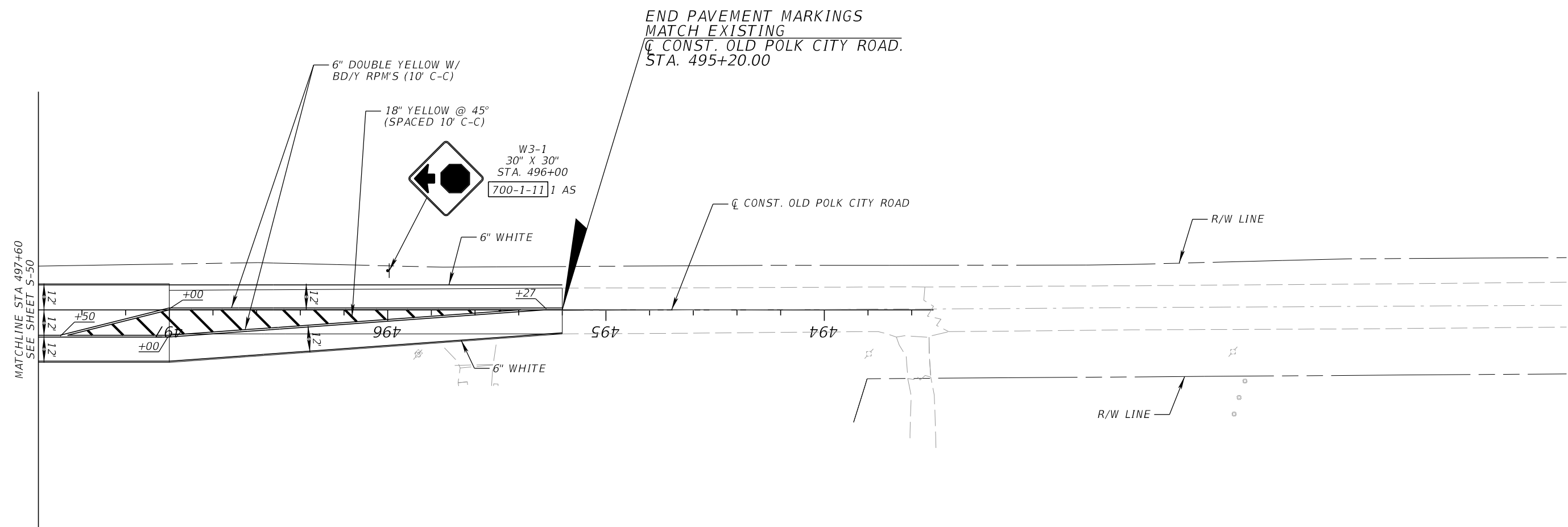
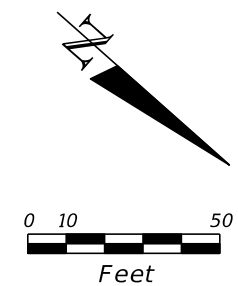

MATCHLINE STA 497+60  
SEE SHEET S-50

REVISIONS				JAMES E. BRADFORD, P.E. P.E. LICENSE NUMBER 68276 DEWBERRY ENGINEERS INC. 800 NORTH MAGNOLIA AVENUE, STE. 1000 ORLANDO, FL 32803	POLK COUNTY PUBLIC WORKS DEPARTMENT			<b>SIGNING AND PAVEMENT            MARKING PLAN</b>	SHEET NO.  S-63
DATE	DESCRIPTION	DATE	DESCRIPTION		ROAD NO.	COUNTY	FINANCIAL PROJECT ID		
						557	POLK		18-73

THE OFFICIAL RECORD OF THIS SHEET IS THE ELECTRONIC FILE DIGITALLY SIGNED AND SEALED UNDER RULE 61G15-23.004, F.A.C.

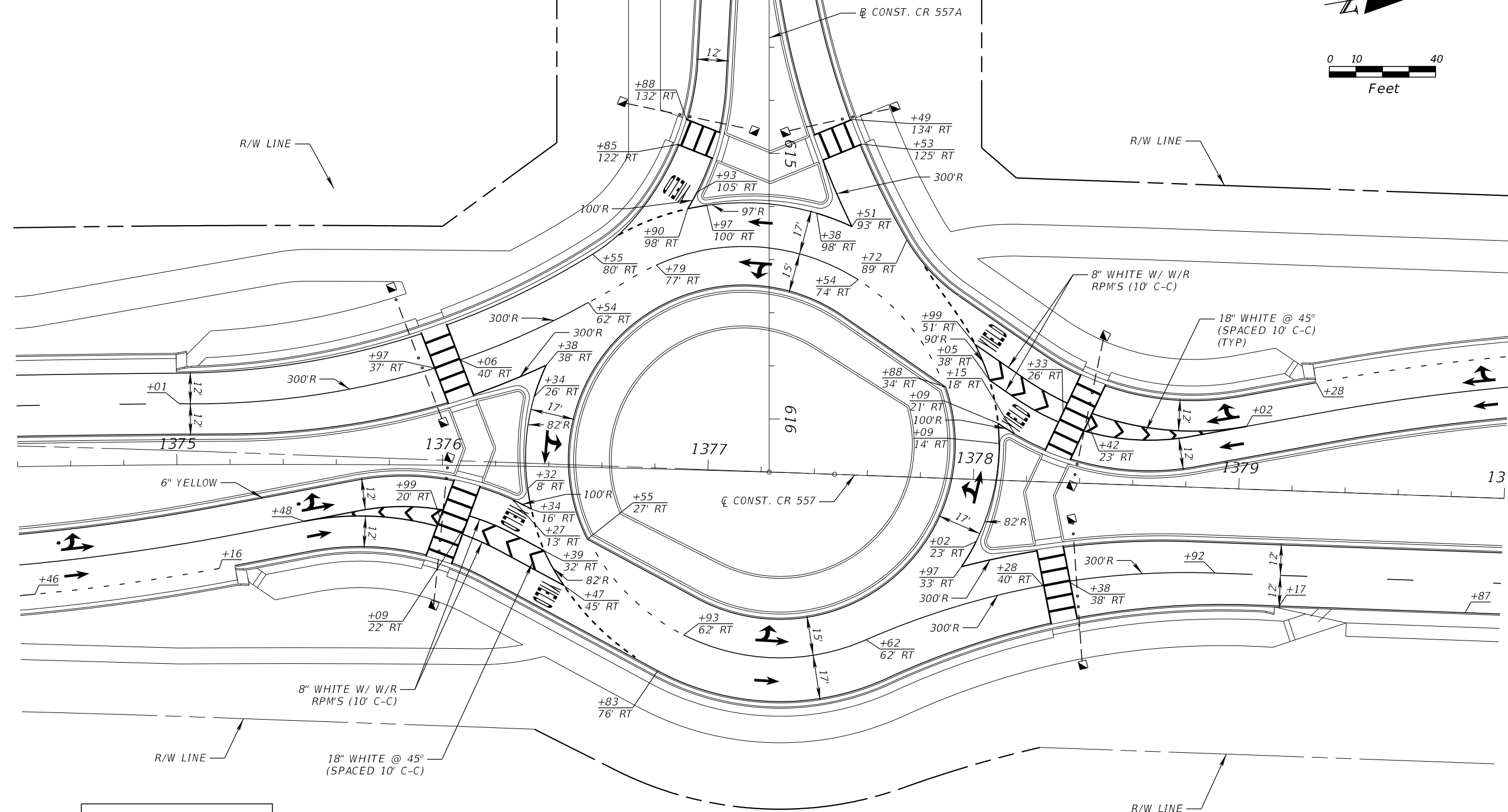
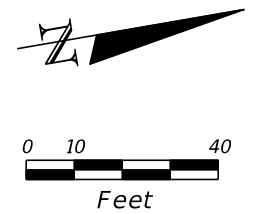

SEE SHEET S-38 AND S-39  
FOR ADDITIONAL INFORMATION

REVISIONS				JAMES E. BRADFORD, P.E. P.E. LICENSE NUMBER 68276 DEWBERRY ENGINEERS INC. 800 NORTH MAGNOLIA AVENUE, STE. 1000 ORLANDO, FL 32803	POLK COUNTY PUBLIC WORKS DEPARTMENT			SHEET NO.  S-64
DATE	DESCRIPTION	DATE	DESCRIPTION		ROAD NO.	COUNTY	FINANCIAL PROJECT ID	
					557	POLK	18-73	

**INTERSECTION DETAILS**

THE OFFICIAL RECORD OF THIS SHEET IS THE ELECTRONIC FILE DIGITALLY SIGNED AND SEALED UNDER RULE 61G15-23.004, F.A.C.



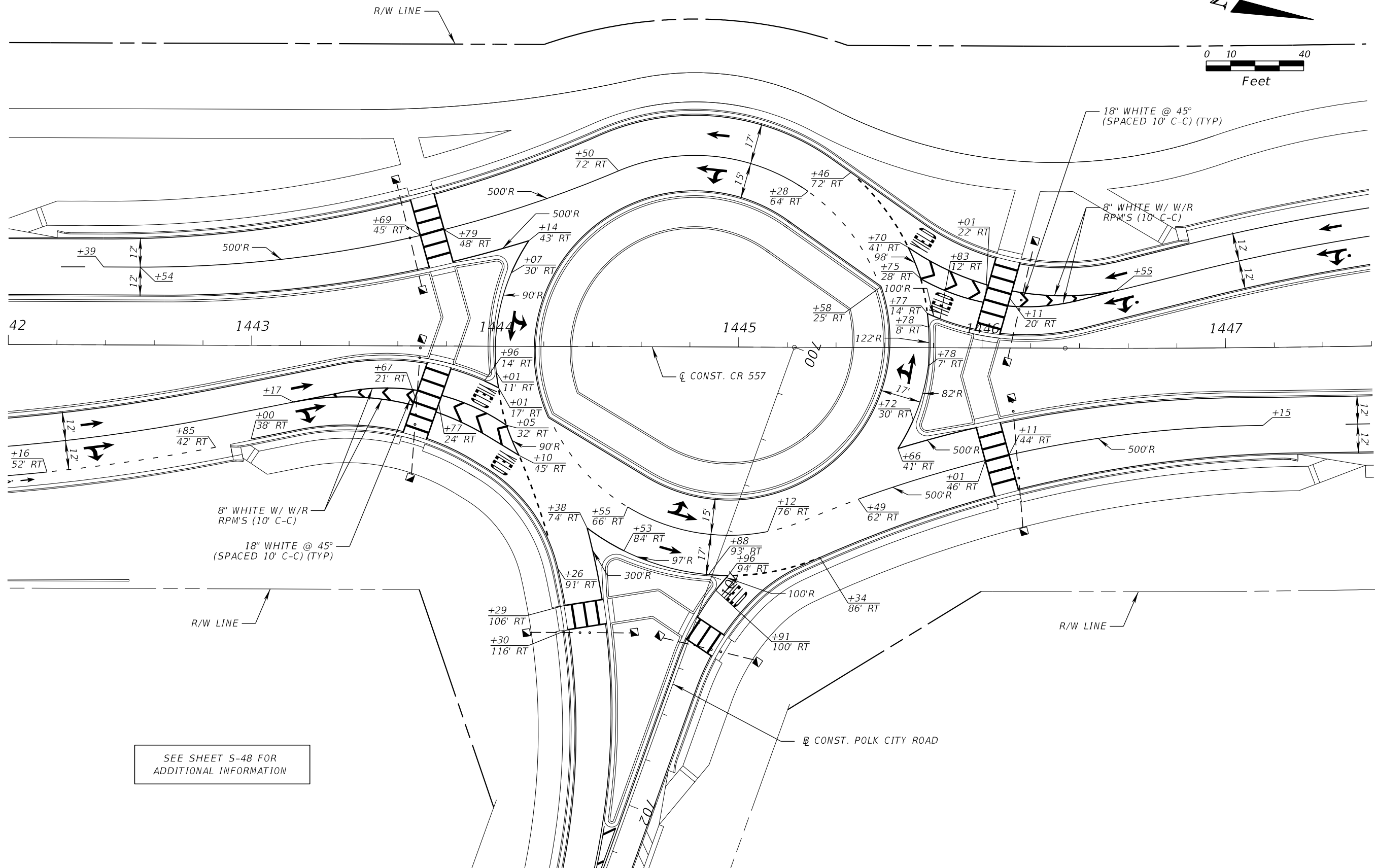
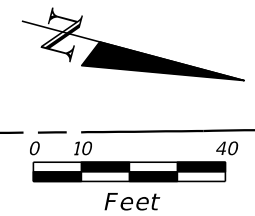

SEE SHEET S-48 FOR  
ADDITIONAL INFORMATION

REVISIONS			
DATE	DESCRIPTION	DATE	DESCRIPTION

JAMES E. BRADFORD, P.E.  
P.E. LICENSE NUMBER 68276  
DEWBERRY ENGINEERS INC.  
800 NORTH MAGNOLIA AVENUE, STE. 1000  
ORLANDO, FL 32803

POLK COUNTY PUBLIC WORKS DEPARTMENT		
ROAD NO.	COUNTY	FINANCIAL PROJECT ID
557	POLK	18-73

**INTERSECTION DETAILS**

SHEET NO.  
S-65

THE OFFICIAL RECORD OF THIS SHEET IS THE ELECTRONIC FILE DIGITALLY SIGNED AND SEALED UNDER RULE 61G15-23.004, F.A.C.

SIGN NUMBER	101
QUANTITY	1
WIDTH	8'-6" (102")
HEIGHT	9'-0" (108")
BORDER WIDTH	1.5"
BORDER RADII	12"
BACKGROUND COLOR	Green
LEGEND & BORDER COLOR	White
STATIONS(S)	See Plans
SHEETING	ASTM TYPE XI

NOTES:  
MOUNTING: GM-1

ROUTE SHIELDS SHALL BE VERTICALLY CENTERED UNDER EACH CARDINAL DIRECTION

SEE ROUTE SHEILD AND ARROW DETAILS, SHEET S-67

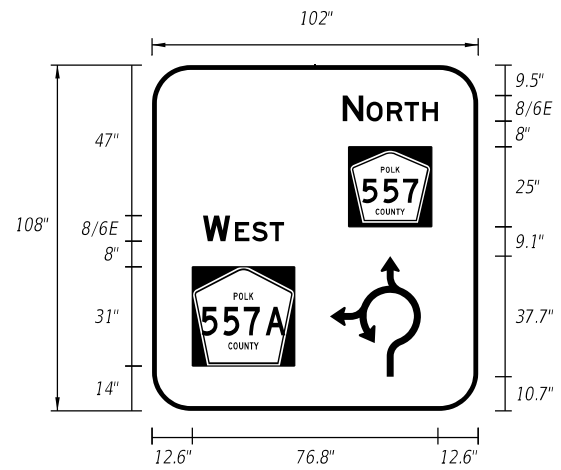

COPY			N O R T H													L		
SPACE	59.6			29.8													29.8	
COPY		W	E	S	T												L	
SPACE	16		25.3					20.2					26				14.5	71.5
COPY			557A															L
SPACE	12.6		32					11.1					28.4				17.9	71.5
COPY																		
SPACE																		
COPY																		
SPACE																		

SIGN NUMBER	102
QUANTITY	1
WIDTH	8'-6" (102")
HEIGHT	9'-0" (108")
BORDER WIDTH	1.5"
BORDER RADII	12"
BACKGROUND COLOR	Green
LEGEND & BORDER COLOR	White
STATIONS(S)	See Plans
SHEETING	ASTM TYPE XI

NOTES:  
MOUNTING: GM-2

ROUTE SHIELDS SHALL BE VERTICALLY CENTERED UNDER EACH CARDINAL DIRECTION

SEE ROUTE SHEILD AND ARROW DETAILS, SHEET S-67

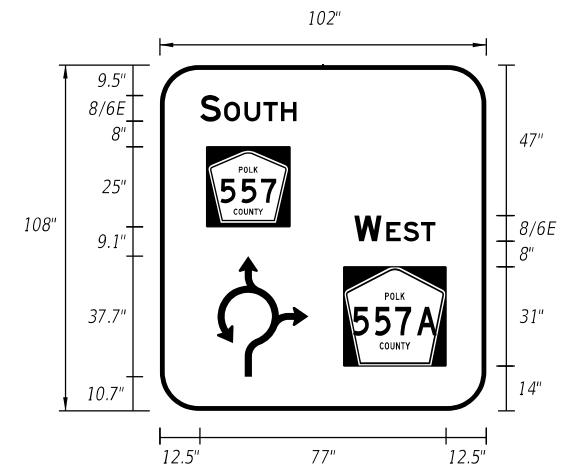

COPY			S O U T H													L			
SPACE	12.5			30.2													59.3		
COPY																		L	
SPACE	14.6						20.2							25.3			15.9	71.5	
COPY				557															L
SPACE	18			28.4					11.1					32			12.5	71.5	
COPY																			
SPACE																			
COPY																			
SPACE																			

SIGN NUMBER	103
QUANTITY	1
WIDTH	11'-6" (138")
HEIGHT	5'-6" (66")
BORDER WIDTH	1.5"
BORDER RADII	9"
BACKGROUND COLOR	Green
LEGEND & BORDER COLOR	White
STATIONS(S)	See Plans
SHEETING	ASTM TYPE XI

NOTES:  
MOUNTING: GM-3

ROUTE SHIELDS SHALL BE VERTICALLY CENTERED UNDER EACH CARDINAL DIRECTION

SEE ROUTE SHEILD AND ARROW DETAILS, SHEET S-67

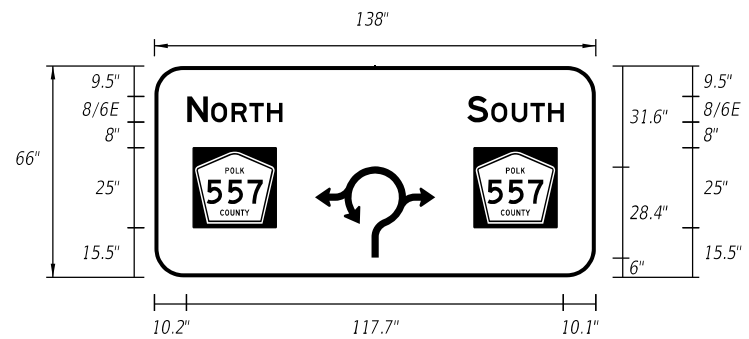

COPY			N O R T H							S O U T H								L				
SPACE	10.2		29.8						10.1					9.9		30.2					10.1	
COPY			557																	L		
SPACE	12.1		26						12					37.7		12	26					12.2
COPY																						
SPACE																						
COPY																						
SPACE																						

SIGN NUMBER	104
QUANTITY	1
WIDTH	11'-6" (138")
HEIGHT	5'-6" (66")
BORDER WIDTH	1.5"
BORDER RADII	9"
BACKGROUND COLOR	Green
LEGEND & BORDER COLOR	White
STATIONS(S)	See Plans
SHEETING	ASTM TYPE XI

NOTES:  
MOUNTING: GM-4

ROUTE SHIELDS SHALL BE VERTICALLY CENTERED UNDER EACH CARDINAL DIRECTION

SEE ROUTE SHEILD AND ARROW DETAILS, SHEET S-67

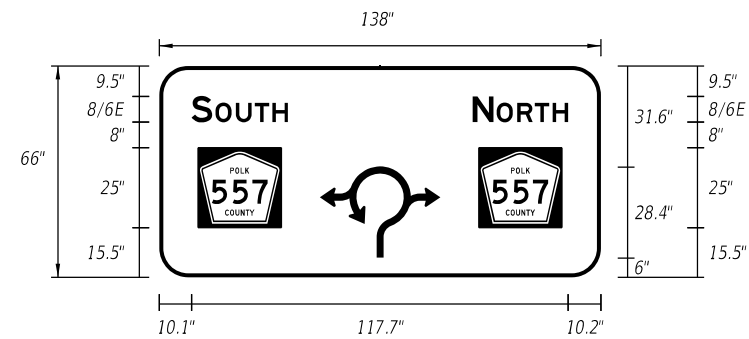

COPY			S O U T H							N O R T H								L				
SPACE	10.1		30.2						9.9					10.1		29.8					10.2	
COPY			557																	L		
SPACE	12.2		26						12					37.7		12	26					12.1
COPY																						
SPACE																						
COPY																						
SPACE																						

REVISIONS			
DATE	DESCRIPTION	DATE	DESCRIPTION

JAMES E. BRADFORD, P.E.  
P.E. LICENSE NUMBER 68276  
DEWBERRY ENGINEERS INC.  
800 NORTH MAGNOLIA AVENUE, STE. 1000  
ORLANDO, FL 32803

POLK COUNTY PUBLIC WORKS DEPARTMENT		
ROAD NO.	COUNTY	FINANCIAL PROJECT ID
557	POLK	18-73

**GUIDE SIGN WORKSHEET**  
**SIGNS 101-104**

SHEET NO.  
S-66

SIGN NUMBER	105
QUANTITY	1
WIDTH	11'-0" (132")
HEIGHT	9'-0" (108")
BORDER WIDTH	1.5"
BORDER RADII	12"
BACKGROUND COLOR	Green
LEGEND & BORDER COLOR	White
STATIONS(S)	See Plans
SHEETING	ASTM TYPE XI

NOTES:  
MOUNTING: GM-5  
ROUTE SHIELDS SHALL BE VERTICALLY CENTERED UNDER EACH CARDINAL DIRECTION  
SEE ROUTE SHEILD AND ARROW DETAILS, SHEET S-67

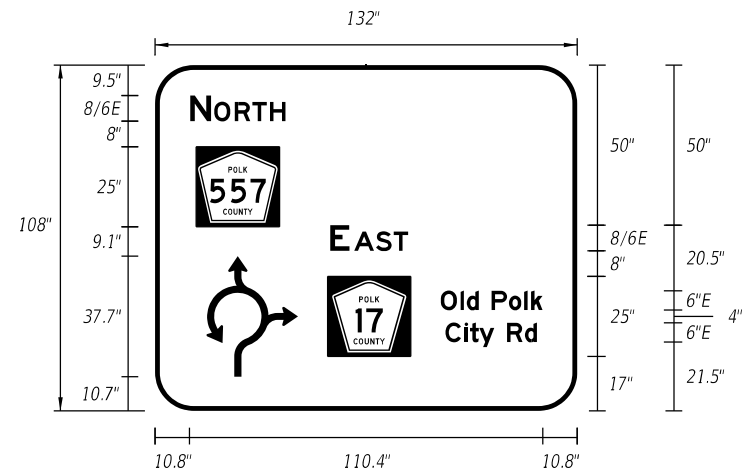

COPY		N O R T H																L	
SPACE	10.8	29.8																91.4 29.8	
COPY		557		E A S T				O l d				P o l k						L	
SPACE	12.8	26		15.9 24.3				10.3 11.9				4 16						10.8 108.4	
COPY		↶		C i t y				R d						L					
SPACE	16.2	28.4		9.3 26				11 15.2				4 9.4 12.5						103.3	
COPY																			
SPACE																			
COPY																			
SPACE																			

SIGN NUMBER	106
QUANTITY	1
WIDTH	11'-0" (132")
HEIGHT	9'-0" (108")
BORDER WIDTH	1.5"
BORDER RADII	12"
BACKGROUND COLOR	Green
LEGEND & BORDER COLOR	White
STATIONS(S)	See Plans
SHEETING	ASTM TYPE XI

NOTES:  
MOUNTING: GM-6  
ROUTE SHIELDS SHALL BE VERTICALLY CENTERED UNDER EACH CARDINAL DIRECTION  
SEE ROUTE SHEILD AND ARROW DETAILS, SHEET S-67

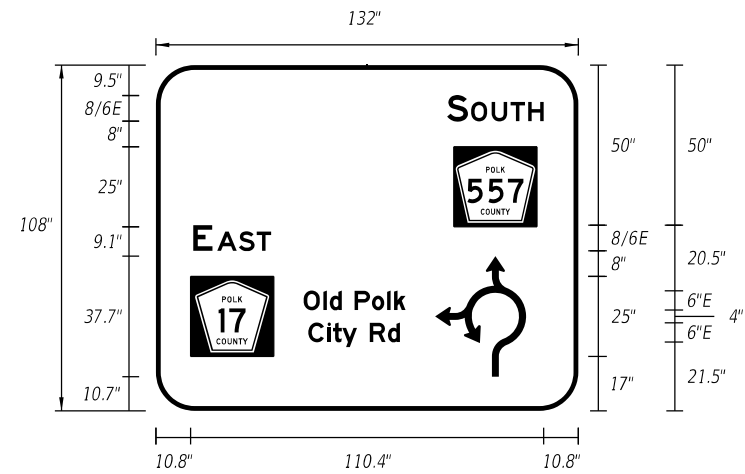

COPY		S O U T H																L	
SPACE	91	30.2																10.8 30.2	
COPY		E A S T				O l d				P o l k						L			
SPACE	11.7	24.3				10 11.9				4 16						15.2 26			
COPY		557		C i t y				R d						L					
SPACE	10.8	26		10.9 15.2				4 9.4 11						28.4 16.3 104.9					
COPY																			
SPACE																			
COPY																			
SPACE																			

SIGN NUMBER	R3-8 (MOD)	BORDER WIDTH	0.825"
QUANTITY	See Plans	BORDER RADII	2.25"
WIDTH	3'-6"	BORDER INSET	0.625"
HEIGHT	3'-6"	NOTE: ALL DIMENSIONS ARE PER THE STANDARD HIGHWAYS SIGNS UNLESS OTHERWISE NOTED ON THIS SHEET	
BACKGROUND COLOR	White		
LEGEND & BORDER COLOR	Black		
STATIONS(S)	See Plans		

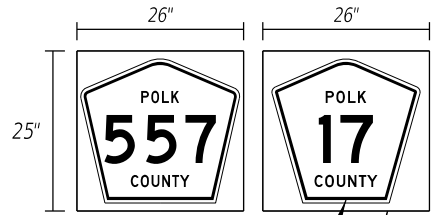

24" HIGH M1-6 SHIELD PER STANDARD HIGHWAY SIGNS  
YELLOW RECTANGULAR BACKGROUND

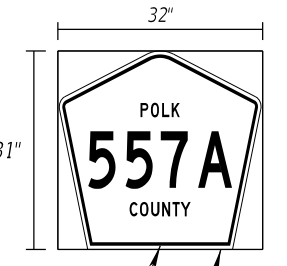

30" HIGH M1-6 SHIELD PER STANDARD HIGHWAY SIGNS  
YELLOW RECTANGULAR BACKGROUND

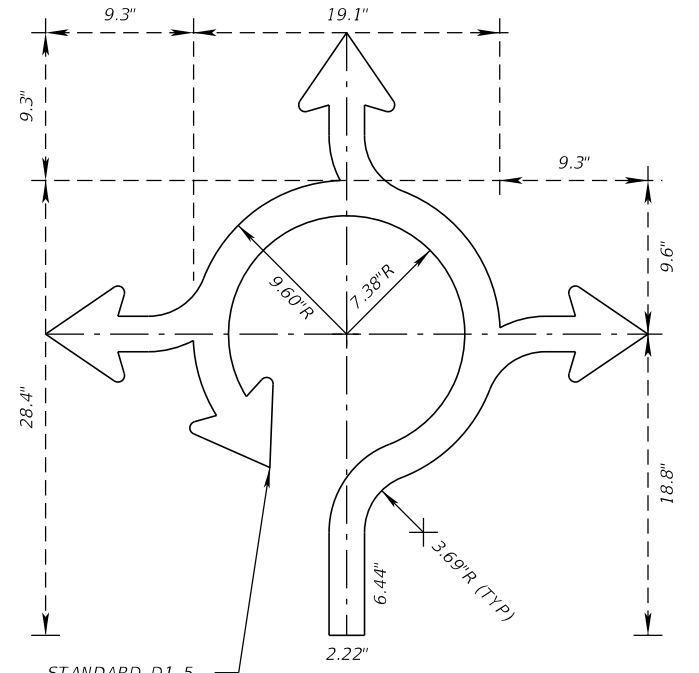
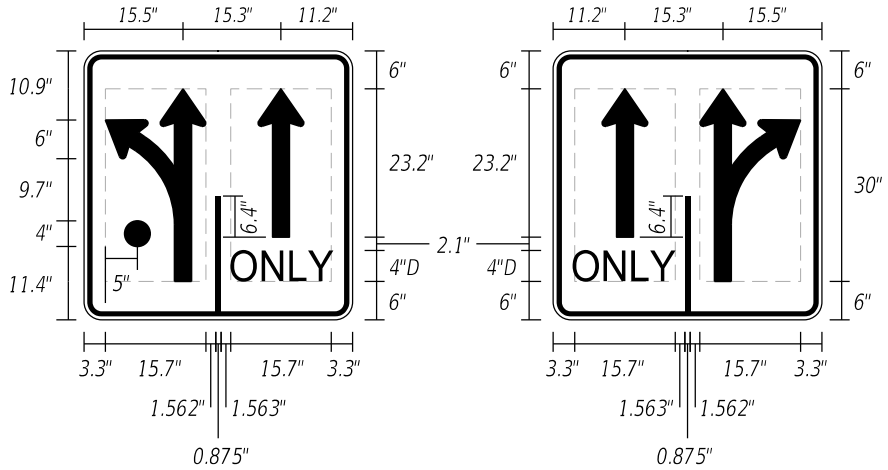

STANDARD D1-5 ARROWHEAD (TYP)

REVISIONS			
DATE	DESCRIPTION	DATE	DESCRIPTION

JAMES E. BRADFORD, P.E.  
P.E. LICENSE NUMBER 68276  
DEWBERRY ENGINEERS INC.  
800 NORTH MAGNOLIA AVENUE, STE. 1000  
ORLANDO, FL 32803

POLK COUNTY PUBLIC WORKS DEPARTMENT		
ROAD NO.	COUNTY	FINANCIAL PROJECT ID
557	POLK	18-73

**GUIDE SIGN WORKSHEET**  
**SIGNS 105-106**  
SHEET NO. S-67

THE OFFICIAL RECORD OF THIS SHEET IS THE ELECTRONIC FILE DIGITALLY SIGNED AND SEALED UNDER RULE 61G15-23.004, F.A.C.



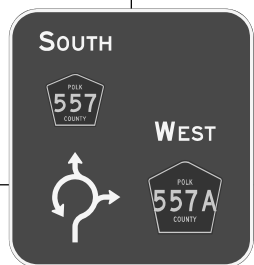
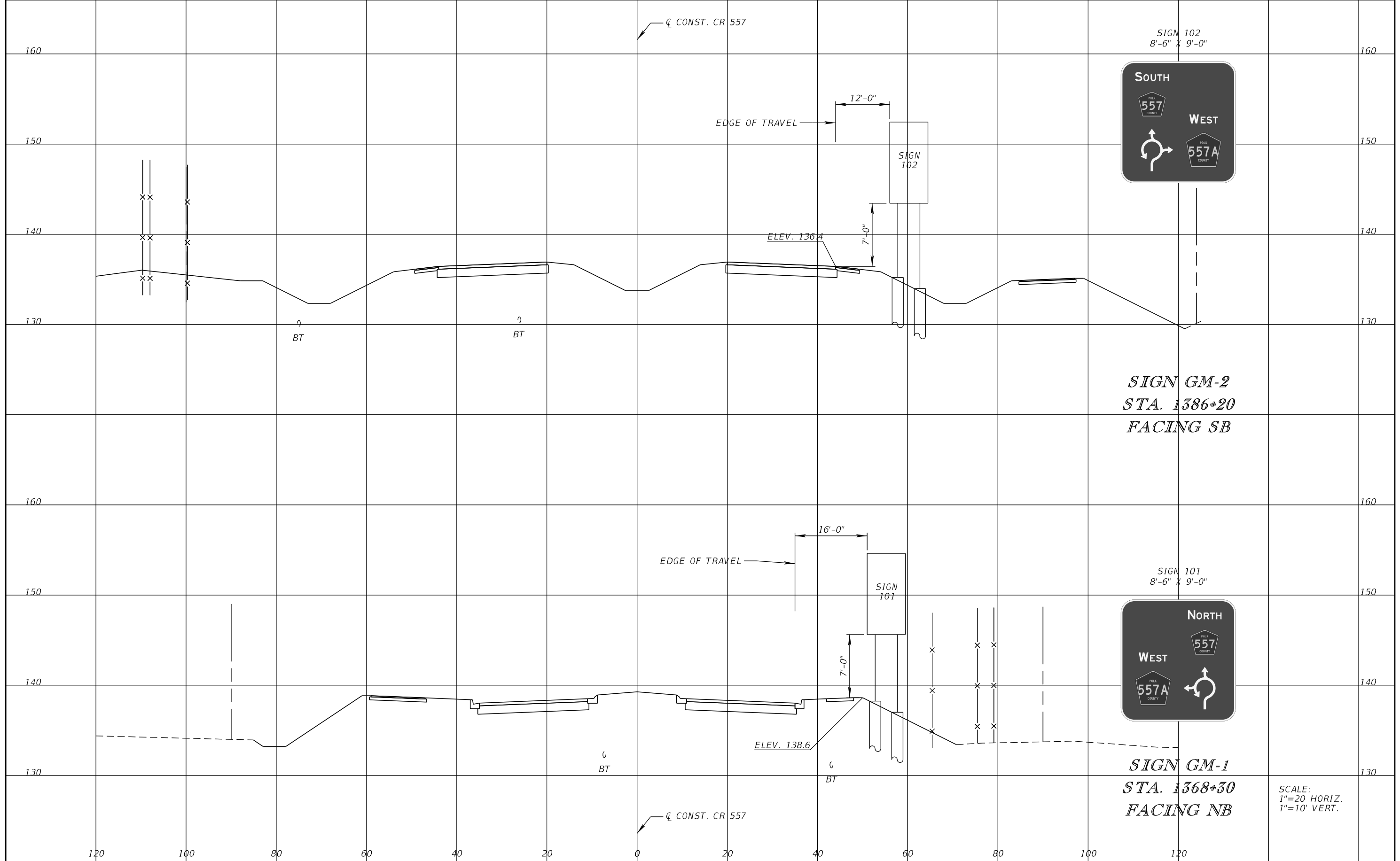

**SIGN GM-2**  
**STA. 1386+20**  
**FACING SB**

**SIGN GM-1**  
**STA. 1368+30**  
**FACING NB**

SCALE:  
 1"=20' HORIZ.  
 1"=10' VERT.

REVISIONS			
DATE	DESCRIPTION	DATE	DESCRIPTION

JAMES E. BRADFORD, P.E.  
 P.E. LICENSE NUMBER 68276  
 DEWBERRY ENGINEERS INC.  
 800 NORTH MAGNOLIA AVENUE, STE. 1000  
 ORLANDO, FL 32803

POLK COUNTY PUBLIC WORKS DEPARTMENT		
ROAD NO.	COUNTY	FINANCIAL PROJECT ID
557	POLK	18-73

**GUIDE SIGN**  
**CROSS SECTIONS**

SHEET  
 NO.  
**S-69**

THE OFFICIAL RECORD OF THIS SHEET IS THE ELECTRONIC FILE DIGITALLY SIGNED AND SEALED UNDER RULE 61G15-23.004, F.A.C.

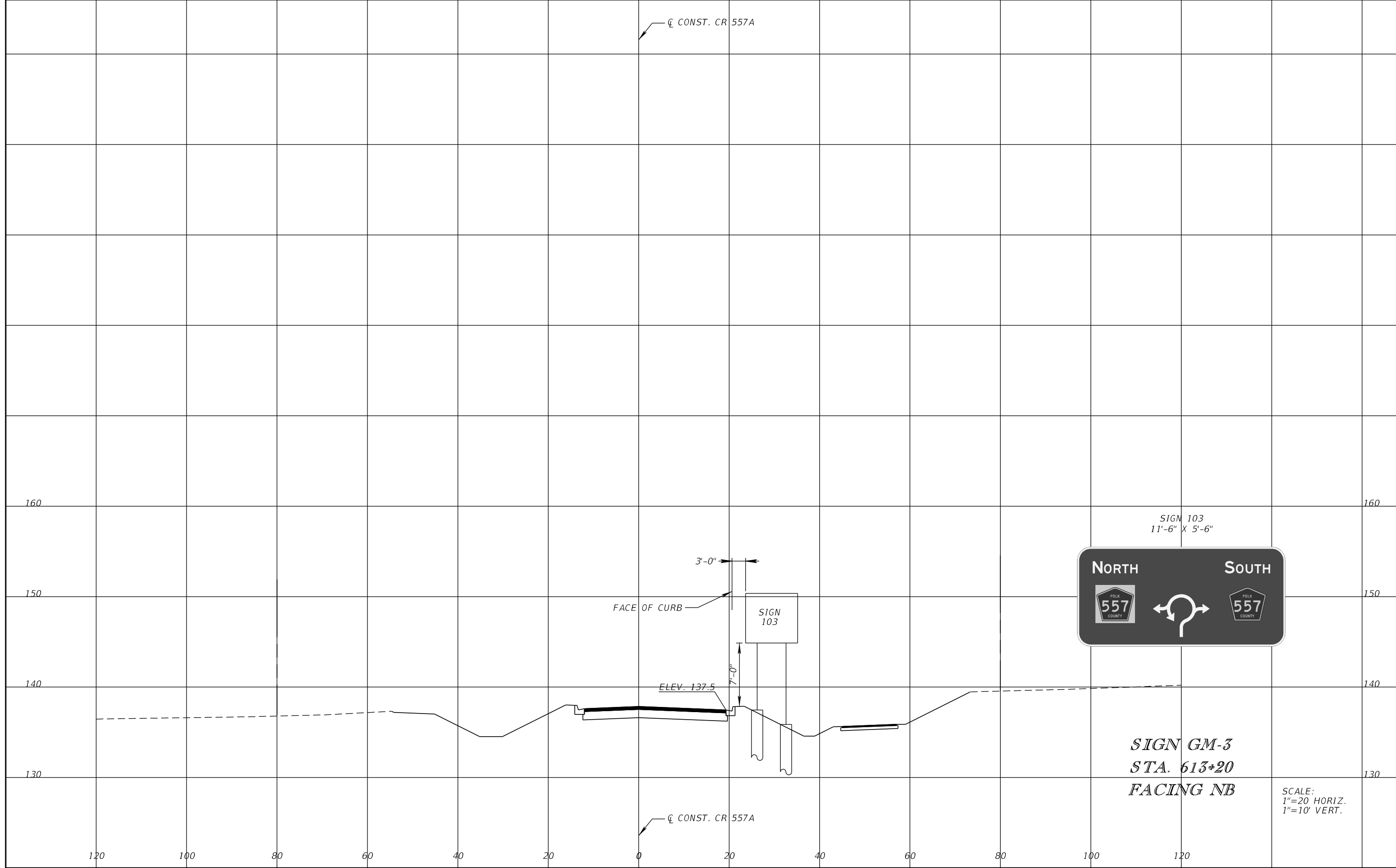

SCALE:  
1"=20' HORIZ.  
1"=10' VERT.

REVISIONS			
DATE	DESCRIPTION	DATE	DESCRIPTION

JAMES E. BRADFORD, P.E.  
P.E. LICENSE NUMBER 68276  
DEWBERRY ENGINEERS INC.  
800 NORTH MAGNOLIA AVENUE, STE. 1000  
ORLANDO, FL 32803

POLK COUNTY PUBLIC WORKS DEPARTMENT		
ROAD NO.	COUNTY	FINANCIAL PROJECT ID
557	POLK	18-73

**GUIDE SIGN  
CROSS SECTIONS**

SHEET  
NO.  
**S-70**

THE OFFICIAL RECORD OF THIS SHEET IS THE ELECTRONIC FILE DIGITALLY SIGNED AND SEALED UNDER RULE 61G15-23.004, F.A.C.

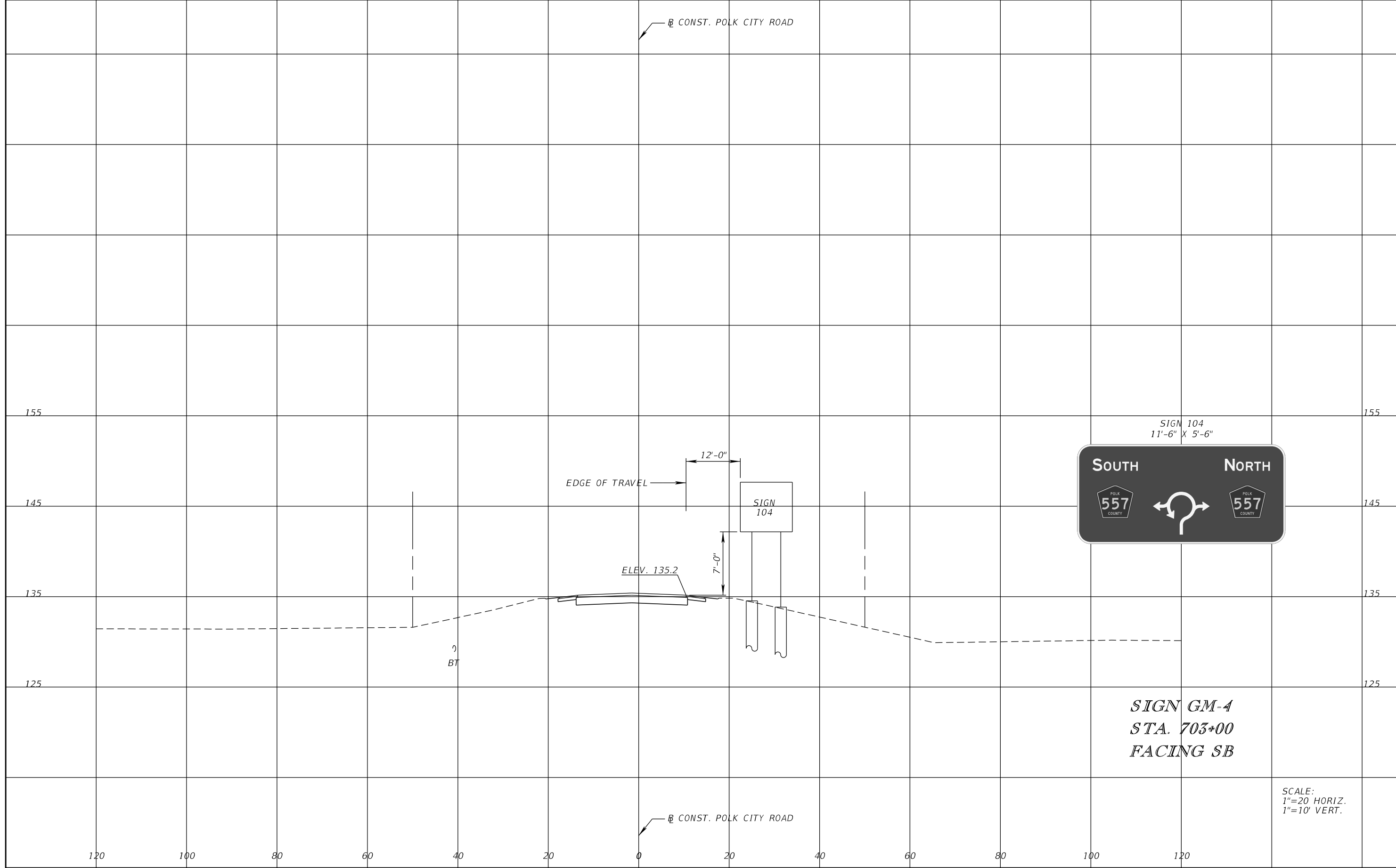

REVISIONS			
DATE	DESCRIPTION	DATE	DESCRIPTION

JAMES E. BRADFORD, P.E.  
P.E. LICENSE NUMBER 68276  
DEWBERRY ENGINEERS INC.  
800 NORTH MAGNOLIA AVENUE, STE. 1000  
ORLANDO, FL 32803

POLK COUNTY PUBLIC WORKS DEPARTMENT		
ROAD NO.	COUNTY	FINANCIAL PROJECT ID
557	POLK	18-73

**GUIDE SIGN  
CROSS SECTIONS**

SHEET NO.  
S-71

THE OFFICIAL RECORD OF THIS SHEET IS THE ELECTRONIC FILE DIGITALLY SIGNED AND SEALED UNDER RULE 61G15-23.004, F.A.C.

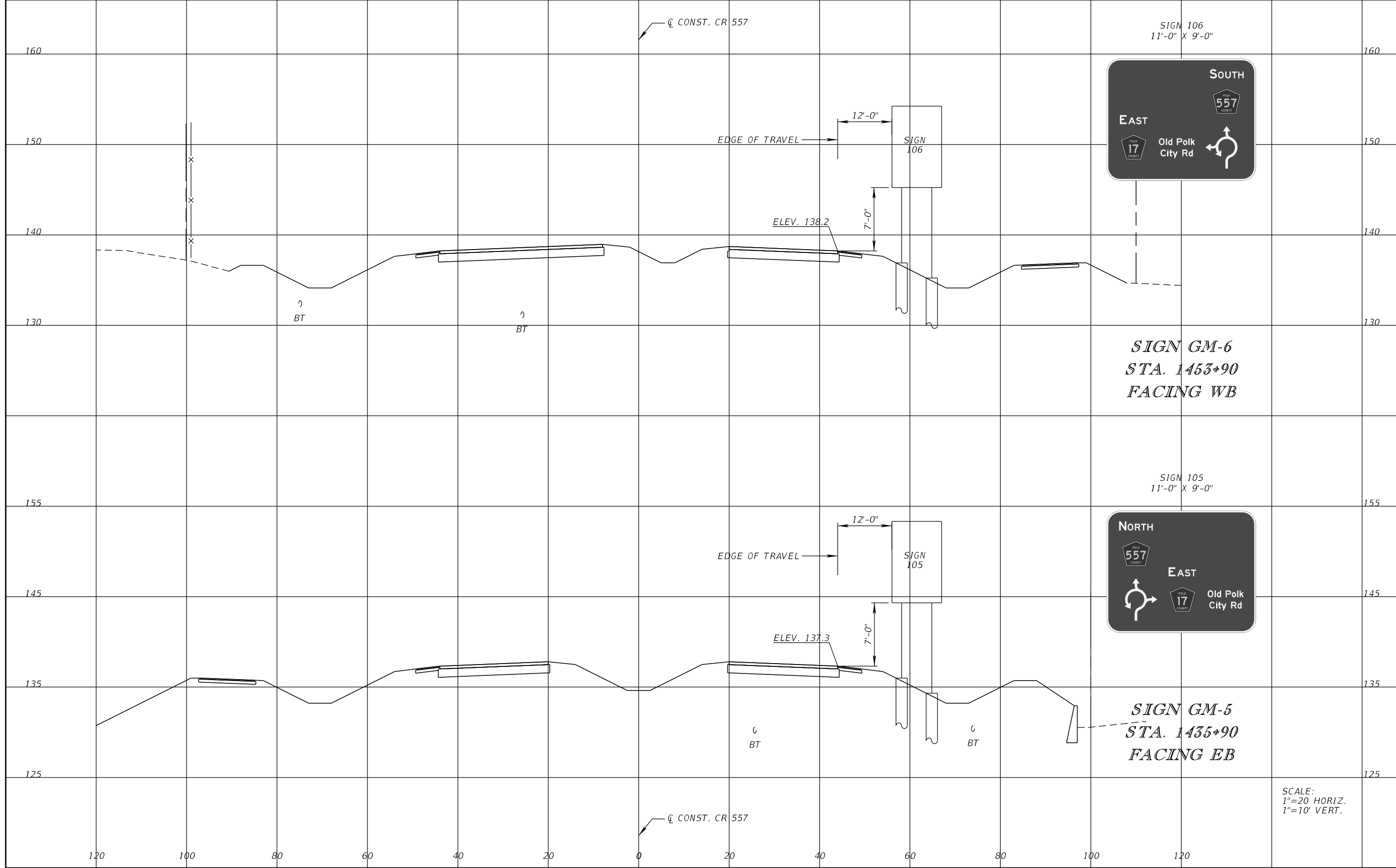

**SIGN GM-6**  
**STA. 1453+90**  
**FACING WB**

**SIGN GM-5**  
**STA. 1435+90**  
**FACING EB**

SCALE:  
 1"=20' HORIZ.  
 1"=10' VERT.

REVISIONS			
DATE	DESCRIPTION	DATE	DESCRIPTION

JAMES E. BRADFORD, P.E.  
 P.E. LICENSE NUMBER 68276  
 DEWBERRY ENGINEERS INC.  
 800 NORTH MAGNOLIA AVENUE, STE. 1000  
 ORLANDO, FL 32803

POLK COUNTY PUBLIC WORKS DEPARTMENT		
ROAD NO.	COUNTY	FINANCIAL PROJECT ID
557	POLK	18-73

**GUIDE SIGN  
 CROSS SECTIONS**

SHEET  
 NO.  
**S-72**

THE OFFICIAL RECORD OF THIS SHEET IS THE ELECTRONIC FILE DIGITALLY SIGNED AND SEALED UNDER RULE 61G15-23.004, F.A.C.



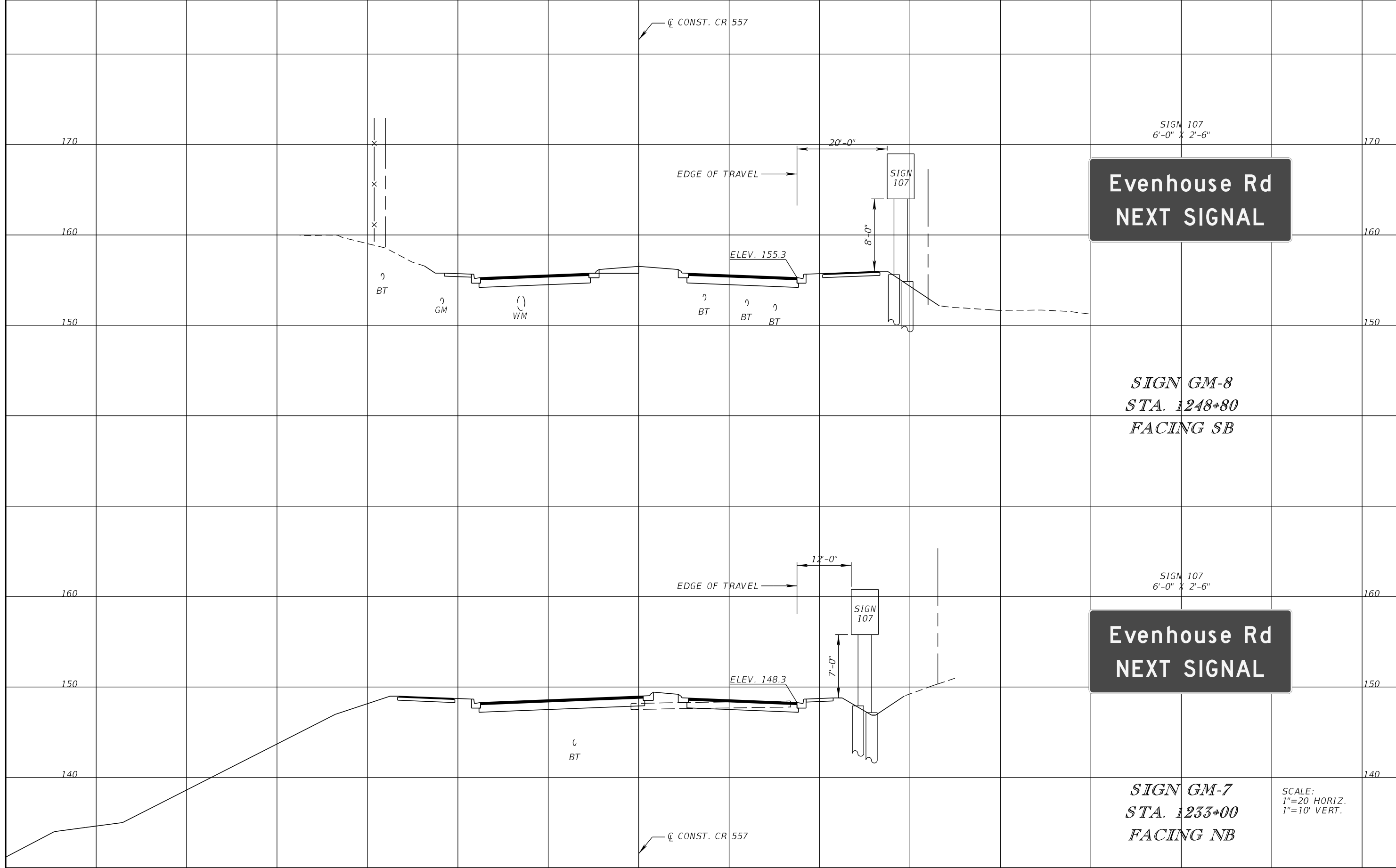

**Evenhouse Rd  
NEXT SIGNAL**

*SIGN GM-8  
STA. 1248+80  
FACING SB*

**Evenhouse Rd  
NEXT SIGNAL**

*SIGN GM-7  
STA. 1233+00  
FACING NB*

SCALE:  
1"=20' HORIZ.  
1"=10' VERT.

REVISIONS			
DATE	DESCRIPTION	DATE	DESCRIPTION

JAMES E. BRADFORD, P.E.  
P.E. LICENSE NUMBER 68276  
DEWBERRY ENGINEERS INC.  
800 NORTH MAGNOLIA AVENUE, STE. 1000  
ORLANDO, FL 32803

POLK COUNTY PUBLIC WORKS DEPARTMENT		
ROAD NO.	COUNTY	FINANCIAL PROJECT ID
557	POLK	18-73

**GUIDE SIGN  
CROSS SECTIONS**

SHEET  
NO.  
**S-73**