



# 2026 Flexible Pavement Condition Survey Handbook



**FDOT Office**  
State Materials Office

**Date of Publication**  
January 2026



# Table of Contents

Title	Page
<u>List of Tables</u> .....	i
<u>List of Figures</u> .....	ii
<u>Executive Summary</u> .....	iii
I. <u>Introduction</u> .....	1
II. <u>Pavement Section Selection and Identification</u> .....	2
III. <u>Evaluation Methods</u> .....	11
<u>Crack Rating</u> .....	11
<u>Rut Rating</u> .....	30
<u>Ride Rating</u> .....	32
IV. <u>Flexible Pavement Condition Survey Field Workbook</u> .....	36
<u>Appendix A – Ride Rating Re-Run Procedure</u> .....	43



## List of Tables

Table		Page
1	<u>Roadway Direction Code</u> .....	4
2	<u>Standard Remarks</u> .....	9
3	<u>Raveling Codes</u> .....	14
4	<u>Patching Codes</u> .....	14
5	<u>Numerical Deductions for Cracking Method</u> .....	16
6	<u>Numerical Deductions for Rutting Methods</u> .....	31
7	<u>IRI to Ride Rating Table</u> .....	34



# List of Figures

Figure		Page
1	<u>Wheel Path Designation</u> .....	17
2	<u>Class I Cracking Estimates</u> .....	18
3	<u>Class II Cracking Estimates</u> .....	19
4	<u>Class III Cracking Estimates</u> .....	20
5	<u>Class I Cracking Classification</u> .....	21
6	<u>Class II Cracking Classification</u> .....	22
7	<u>Class III Cracking Classification</u> .....	23
8	<u>Class I Cracking Photo</u> .....	24
9	<u>Class II Cracking Photo</u> .....	25
10	<u>Class III Cracking Photo</u> .....	26
11	<u>Patching Photo</u> .....	27
12	<u>Raveling Photo</u> .....	28
13	<u>Pumping Photos</u> .....	29
14	<u>Rut Depth Methods</u> .....	31
15	<u>LCMS/Inertial Profiler Photo</u> .....	35

# Executive Summary

This handbook has been developed as a guide for personnel responsible for conducting the Florida Department of Transportation Pavement Condition Survey (PCS) on flexible pavements and to ensure consistency among raters. It also serves as a reference for staff in each district involved in the PCS data verification process. This reference describes the procedures for conducting a visual, mechanical and automated condition evaluation of the Department's flexible pavement system. Items evaluated in the survey include:

1. Class I Cracking
2. Class II Cracking
3. Class III Cracking
4. Raveling
5. Patching
6. Pumping
7. Profiler Rut Depth (automated)
8. Ride Quality (roughness)

The data collected during the PCS is used as input into the pavement management system and for project prioritization purposes.

Keywords: Crack Rating, Ride Rating, Rut Rating, International Roughness Index (IRI), Ride Number (RN), Pavement Evaluation, Flexible Pavement Condition Survey, Profiler, Roadway Characteristics Inventory (RCI), Straight Line Diagram (SLD)

# I. Introduction

The present condition of Florida's flexible pavement system is of interest to Pavement Management, Design, Planning, Maintenance, consultants, and other groups within the Florida Department of Transportation.

The information provided in this handbook describes the methods used to evaluate surface distresses, determine the ride quality, and the rut depth of flexible pavement. Any mention of rigid pavement is only discussed when necessary for the completion of the Flexible Pavement Condition Survey. For information relating to the evaluation of rigid pavements, please refer to the Rigid Pavement Condition Survey Handbook.

The results of this evaluation provide information that is used in conjunction with other data for the following purposes:

1. Determine the present condition of the State Highway System
2. Compare present with past condition
3. Predict future deterioration rates
4. Estimate rehabilitation funding needs
5. Provide justification for the annual pavement rehabilitation budget
6. Provide justification for prioritizing rehabilitation projects
7. Provide justification for distribution of rehabilitation funds to Districts

The various changes and enhancements that have been implemented with each survey are recorded in the "History of Florida Pavement Condition Survey" at the following address:

<http://www.fdot.gov/materials/pavement/performance/pcs/pcshistory.pdf>

## II. Pavement Section Selection and Identification

The length of the pavement to be evaluated will vary depending upon many factors. Typical factors that create section limits (rated sections) include the following:

1. County line.
2. County section or subsection.
3. Construction limits.
4. Significant changes in pavement condition.
5. Structures 0.25 miles or more.
6. Rigid pavement 0.25 miles or more within a flexible pavement section.
7. Changes in the number of lanes 0.25 miles or more (2 to 3 lanes, etc.)
8. A division between roadway directions 0.50 miles or more.
9. System Status

As implied by the list above, a certain amount of office preparation is required prior to the field evaluation. The rater should have access to straight line diagrams (SLD), Skyview, maps, Roadway Characteristics Inventory (RCI) data, and historical Pavement Condition Survey (PCS) data for those roadways to be evaluated.

### **Construction Limits**

Section limits should be based initially upon construction project limits. The section may deteriorate at different rates, requiring additional “breaks” within the overall section, but the beginning and ending mileposts must not be modified. To preserve the history of PCS data, section limits must only be changed if the limits of a new construction project extend into previously existing project limits.

## **Section Length**

If possible, do not break new sections under 0.25 miles in length. Do not combine existing adjacent sections because they have the same or similar crack rating. This does not warrant combining into one section. The only time a section should be combined with another section is short sections (less than a 0.25 mile) that are left over after new pavement or under construction have been broken out. Combine these sections with the next or previous section with similar crack ratings. If the section cannot be combined due to crack ratings or other reasons leave as a short section less than a 0.25 mile (Orphan section). If the section is 0.10 miles or less do not break out, leave it with the original section. Maintain original section limits and treat as a maintenance issue not representative of the section until new section starts deteriorating. Add comments in the comment column.

## **Roadway Direction**

The direction a section is rated depends on the following criteria:

### **Divided**

Any pavement section 0.50 mile or greater that has a division in roadway directions (physical median, island, permanent barrier wall, paved turn lane, or emergency lane) separating traffic traveling in different directions. One lane in each direction must be rated for divided roadways.

### **Undivided (Composite)**

Pavement sections without dividers or sections where any consecutive divided segment is less than 0.50 miles are considered undivided. One lane in only one direction must be rated. Rate these sections in the same direction each year unless an obvious difference exists based upon visual observation of the pavement condition. In this case, the rater must rate the direction having the greatest number of distresses and the direction should remain the same. In cases where new center turn lanes are added to undivided sections break out sections less than 0.50 miles for cracking but do not classify as divided. If center turn lanes are added during a resurfacing project do not break out turn lanes shorter than 0.50 miles.

The Roadway Code is coded in the Roadway column of the Field Workbook and is determined by the pavement division and milepost direction of the rated lane. See **Table 1** below.

**TABLE 1**  
**ROADWAY DIRECTION**

<b>ROADWAY CODE</b>	<b>PAVEMENT DIVISION</b>	<b>MILEPOST DIRECTION</b>	<b>DIRECTION (NOTE1)</b>
1	Undivided	Ascending	North or East
4	Undivided	Descending	South or West
2	Divided	Descending	South or West
3	Divided	Ascending	North or East

Note 1: A limited number of sections have mileposts that are descending in the North or East direction or are ascending in the South or West direction. For example, the PCS Roadway designation of a 1 or 3 could be South or West. Refer to the construction plans or SLD for clarification if needed. Regardless of these exceptions to the rule, a Roadway code of 1 or 3 is always evaluated in the ascending direction and a code of 2 or 4 is always evaluated in the descending direction.

### **Pavement Type (Type)**

The Type column of the Field Workbook is used to denote the surface type of the roadway as well as other conditions the rater observes while performing the survey. The following is a list of all Type codes used:

#### **Exceptions (Type 0)**

Exceptions are pavement sections that are not state-maintained or sections that overlap other state-maintained sections and have been rated under another county section number.

#### **Asphalt Pavement (Type 1)**

Type 1 is for standard asphalt pavement sections. These sections must include Crack, Rut and Ride Ratings.

## **Pavement Improvement (Type 2)**

Type 2 is for sections that have been partially rehabilitated or modified to improve the section. This includes but is not limited to: short maintenance overlays, intersection overlays, sealed cracks, large areas of patching or manhole adjustments. This code is used to note that changes to the pavement surface were made that may influence the Crack, Rut or Ride Ratings. This can result in either positive or negative changes to any rated metric: cracking, rutting or ride. Workbook comments must be provided to explain why the section was rated Type 2. In the following survey year this code must be changed, usually to Type 1, unless additional improvements are made.

## **Skin Patch (Type 3)**

Type 3 is for sections that have large areas covered by a thin overlay or skin patch (often applied as a maintenance overlay). These areas are considered patching. Combine estimates of patching with Class III cracking and include in the rating for entire section.

## **Rigid Pavement (Type 4)**

Type 4 is for rigid pavement sections. No rigid defect ratings should be recorded in the Flexible PCS for these sections. The flexible and rigid profiler data (net length, IRI) gets recorded in the flexible workbook.

## **New Construction (Type 5)**

Type 5 is for a newly constructed section of roadway. As an example, when an undivided roadway has new construction that changes it to a divided roadway, the lanes added in the new direction are coded as Type 5. The following year this code must change, usually to Type 1.

## **No Ride (Type 6)**

Type 6 is for sections where the profiler is unable to achieve a repeatable Ride Rating. These are normally sections that are very short, but sometimes other longer sections have characteristics that the profiler is unable to repeat. These sections are usually in urban areas and have features such as cross streets with signalized intersections and radical intersecting profiles. Collect profiler data, but do not report ride values for these sections.

## **New Pavement (Type 7)**

Type 7 is for sections of existing roadway, where previous pavement, flexible or rigid, have been resurfaced. The following year this code must change, usually to Type 1.

If a section that is New Pavement (Type 7) is also a No Ride (Type 6), code as New Pavement (Type 7) and do not report ride values. Validate Workbook shows New Pavement (NP) and No Ride (NR) in the Combined Remarks column.

Acceptance Overrides:

At the end of each survey year laser acceptance data are manually entered into the PCS Handbook as a Type 7.

## **Under Construction (Type 8)**

Type 8 is for areas that are under construction (UC) during the survey. Only call milled areas or temporary pavements that are 0.25 miles or more as under construction. If it is less than 0.25 miles, hold it out and add a comment as to why the rough distance is short.

Make sure all data is collected through the entire length of the UC area. This data goes to FHWA for HPMS but gets held out for PCS. The Type 8 code can be used for more than one year if construction is noted in the next survey.

After construction is complete the section will typically change to Type 2 or Type 7 depending on the scope of the project. Upon returning the following year, it may be evident that no rehabilitation took place. In this case the section must be coded Type 1 and Not New Pavement (Not NP) coded in Remarks, Not NP remarks from previous year should be removed each year.

## **Structures (Type 9)**

Type 9 is for structures including bridges, box culverts and other permanent objects that are 0.25 miles or more. These structures should be represented by separate pavement section limits and coded as Type 9. Any structure less than 0.25 miles must remain combined with the larger section and profiler roughness turned off. Crack, Rut or Ride Ratings must not be reported for any structure.

Mileposts recorded for structures and exceptions must come from SLD or RCI whenever possible, not from a distance-measuring instrument. This allows for data cross checks with RCI feature code 258.

If a structure is located between a flexible and rigid pavement section, coding as Type 9 in the flexible pavement survey adds the mileage for the structure to the flexible pavement system

## **Add Ins (Type 10)**

Type 10 is used to record pavement sections that have been added to the state-maintained system after the survey was completed. This allows the mileage to be included in the survey and serves as a reminder for the rater to rate the section the next year. When Type10 is used in these instances, always code the number of lanes and Remarks containing ADD in xx, where xx = year of next survey.

## **Lanes**

For undivided roadways, this is the total number of thru travel lanes. For divided roadways, this is the number of through lanes in the direction of travel. Do not include turn lanes, parking lanes or emergency lanes in the number of lanes. The total number of lanes must agree with RCI feature code 212 (Thru Lanes).

## **Rated Lane**

The lane having the worst pavement condition, based upon visual observation, shall be the rated lane for the direction being tested. It is coded in the Rated Lane column of the Field Workbook. This value is noted by ascending (R) or descending (L) followed by the count of through lanes starting from the inside lane to the lane being rated. For example, a road with 3 lanes in each direction, the middle lane in the ascending direction is R2, and the inside lane in the descending direction is L1.

## **Verification**

The Verification (Ver) column is used to denote results of the verifications done per district request and to record the status of any re-runs due to ride data not matching previous year's data.

When a district requests verification of a rated section, it is re-evaluated for Crack Rating using Laser Crack Measurement System (LCMS) images. If data or images are not available, a field visit may be required. If the results of this re-evaluation determine that the original Crack Rating was correct, an "A" is placed in the Verification column to denote that the re-evaluation agreed with the original rating. If the results determine the original Crack Rating was incorrect, the change(s) are made, and a "C" is placed in the Verification column. This value remains in the next version of the workbook (next year) so the rater is aware that the verification was performed. This code should be removed after running the section during the next survey year.

If a rerun was performed (according to **Appendix A**) by the operator and the previously collected ride data was replaced by the ride data collected during the re-run, a "U" is placed in the Reruns column in the workbook to denote that the re-run was used. If ride data collected during the re-run is not used, an "N" is placed in the Reruns column to denote that the re-run was not used.

## **Remarks**

The Remarks column is used to record information regarding the condition of the section being rated. See **Table 2** for a detailed listing of all standard remarks.

**TABLE 2**  
**STANDARD REMARKS**

<b>REMARKS</b>	<b>STANDARD CODE</b>
New Pavement (A) (see note <sup>1</sup> )	NP
New Construction (A)	NC
Under Construction (A)	UC
Not New Pavement (A)	NOT NP
Bridge Number	BR #####
Rigid Pavement (A)	Rigid Pavt
No Ride (A)	NR
Patching (A)	PT
Raveling (A)	RAV
Off RCI (A)	Off RCI
Survey Next Year	Add in XX (XX = Survey Year)
Lane Realignment	RAL
Brick Crosswalks	BW
Manholes in wheel path	MH
Rippling	RIP
Depressions	DEP
Bleeding	BLD
Shoving	SHV
Delamination	DEL
Spalling	SPL
Potholes	PH
Corrugations	COR
Sealed Cracks	SLDCK
Crowning	CRN
Transverse Cracking	TRVCK
Scaring	SCR
Speed Reduction Device (i.e. Rumble Strips)	RS
Grooved Rumble Strips (Edge & Center Line)	GRS
Pumping	PMP

**Note<sup>1</sup>:** An (A) after the remark in the REMARKS above column indicates an automated remark (based upon an entry in another field).

## **Comments**

The Comments column is used to record information specific to the section that will assist the rater in future surveys. Examples include County section numbers for exceptions and any other non-standard remarks that will help identify the section. This column can also contain standardized remarks that exceed the seventeen-character limit of the Remarks column. This column is also used to provide detailed comments as to why an area is a Type 2 or comments that can assist the reviewer of the section rating. The PCS Administrator may also use this to pass along information to the Rater the following year. Raters should remove comments that do not need to be carried over to next year.

### **III. Evaluation Methods**

Data collection is accomplished with an LCMS together with an inertial profiler and a visual crack assessment by the technician. The roadway must be completely dry before data collection. LCMS sensors are not suitable for wet pavement because water interferes with the laser and camera measurements, leading to inaccurate data.

#### **Automated Crack Rating**

The LCMS calculates cracking by using high-resolution 3D laser scanning technology to capture detailed profiles of a road surface, allowing its software to identify and measure cracks based on changes in surface elevation, effectively detecting cracks by analyzing the depth and width variations in the 3D data across the road surface, differentiating them from other pavement features like texture or markings; this provides a data driven and objective assessment of cracking compared to traditional visual inspections. The system collects forward, 20-foot downward (3D and Range) images of the pavement surface and pavement rutting. Images are processed in the office for distresses present within each roadway section are identified and measured using International Cybernetics Company (ICC) Connect software.

Some of the pavement sections contain specific elements that are intentionally excluded from automated crack rating data because the Department does not wish to include in the Crack Rating values. These are listed below:

- Bridges
- Railroad crossings
- Speed attenuating devices (rumble strips and speed bumps/humps)
- Crosswalks (brick or textured pattern)
- Rigid Pavement intersections (less than 0.25 miles)
- Rigid tractor crossings

## Visual Crack Rating

Consideration is given to three classes of cracking in flexible pavements. The classes of cracks are described as follows:

- Class I -** Hairline cracks that are less than or equal to  $\frac{1}{8}$  in (3.18 mm) wide in either the longitudinal or transverse direction. These are mostly single cracks with no or only a few connecting cracks, cracks are not spalled, and pumping is not evident. These cracks are estimated individually for the total linear length of the cracks. The width of the affected area is considered 1 ft (0.30 m). See **Figures 2, 5 and 8**.
- Class II -** Cracks greater than  $\frac{1}{8}$  in (3.18 mm) and less than or equal to  $\frac{1}{4}$  in (6.35 mm) wide in either the longitudinal or transverse direction. These may have slight spalling and/or advanced branching; pumping is not evident. Also includes all cracks less than or equal to  $\frac{1}{4}$  in (6.35 mm) wide that have formed cells less than or equal to 2 ft (0.61 m) on the longest side, also known as alligator cracking. Class II cracks are considered rectangular, and the total affected area in square feet is counted. See **Figures 3, 6 and 9**.
- Class III (including Raveling and Patching) -** Cracks greater than  $\frac{1}{4}$  in (6.35 mm) wide that extend in a longitudinal or transverse direction and cracks that are opened to the base or underlying material. These cracks often exhibit moderate or severe spalling, and often form a complete pattern, such as alligator cracking. They also include progressive Class II cracking with severe spalling or pumping. Class III cracks are considered rectangular, and the total affected area in square feet is counted. See **Figures 4, 7 and 10**.

**Pumping** - Pumping occurs when there is water in the underlying layers beneath the roadway. The water is physically pumped to the surface through small cracks and pores under heavy moving loads. Pumping is a particularly severe defect causing premature asphalt failure in a variety of ways. If water is being pumped from below the asphalt it can cause stripping or undermining of base, subbase, and subgrade materials. This defect is typically seen by observing the base material on the roadway around the cracks. Pumping must be counted as Class III regardless of crack width. See **Figure 13**. Pumping is not accurately detected by the LCMS and sections containing pumping throughout would use the rater's visual estimate for crack rating.

**Sealed Cracks** – For these areas use same Crack Class as previously rated unless rater sees crack width increase. Unsealed cracks and cracks that form after crack seal has been applied are rated according to the usual method.

**Raveling** - Raveling is the wearing away of the pavement surface caused by the dislodging of aggregate particles in an open graded friction course. See **Figure 12**. Only record raveling for sections having at least one percent of its area raveled.

Raveling percentage is determined by an automated method from LCMS data. The deductions are calculated from the percentages of raveling found in the LCMS images.

The severity levels used to describe raveling are as follows:

**Light** - The aggregate and/or binder have begun to wear away but has not progressed significantly, with some loss of aggregate.

**Moderate** - The aggregate and/or binder has worn away and the surface texture is becoming rough and pitted; loose particles generally exist; loss of aggregate has progressed.

**Severe** - The aggregate and/or binder has worn away and the surface texture is very rough and pitted, loss of aggregate very noticeable.

Record the predominant severity level and percent affected area of raveling in the Raveling column of the field workbook using the codes shown in **Table 3**.

**TABLE 3**  
**RAVELING CODES**

PERCENT OF PAVEMENT AREA	RAVELING SEVERITY LEVEL AND CODE		
	LIGHT	MODERATE	SEVERE
1-5	1	1	1
6-25	2	2	2
26-50	3	3	3
51-100	4	4	4
Note: Code the Predominant severity level only			

**Patching** - A patch is an area of the pavement that has been replaced with newer material after the time of original construction. Only note patching when it covers a defect in the pavement that has been repaired. See **Figure 11**. Only record patching for sections having at least one percent of its area patched.

Record the percentage of pavement area affected by patching by using the codes shown in **Table 4**.

**TABLE 4**  
**PATCHING CODES**

<b>PERCENT OF PAVEMENT AREA AFFECTED BY PATCHING</b>	
<b>PERCENT</b>	<b>CODE</b>
<b>1-5</b>	<b>1</b>
<b>6-25</b>	<b>2</b>
<b>26-50</b>	<b>3</b>
<b>51-100</b>	<b>4</b>

**Calculating Visual Crack Rating**

To calculate the total area affected by cracking, combine the percent area affected estimations as follows:

**Class I + Class II + Class III + Raveling + Patching = Total Percent Affected Area**

Determine the predominant class of cracking, by combining values for percent affected area for Raveling and Patching with Class III cracking estimates. Next, compare the percent affected area from the three classes of cracking (with Class III cracking now including Patching and Raveling). The predominant crack class has the highest percent affected area value.

These values must be determined for cracking confined to the wheel path (**CW**) and cracking outside of the wheel path (**CO**), each representing 100 percent of their respective areas. See **Figure 1** for a diagram of this wheel path designation. **Table 5** explains how to determine the final Crack Rating.

**Crack Type**

The Crack Type field is used to indicate the predominant Crack type for a pavement section. These crack types help in determining the cause of cracks. Crack type Codes are as follows: Alligator (A), Block (B), Combination (C), Raveling (R) and Patching (P). One of these is required if cracking is present. Use the R or P code if either of these defects are the major defect contributing to your crack rating. Leave Crack Type blank only if there is no cracking present.

## Crack Source Determination

As a quality assurance check, the Automated Crack Rating (A) is compared to the Visual Crack Rating (M) and a manual image review is performed in the office and a determination is made by an experienced image reviewer when the following conditions exist.

- Current year's LCMS CR is 0.25 greater than the previous year's Reported CR.
- Current year's LCMS CR is 1.0 lower than the previous year's Reported CR.
- Current year's LCMS CR is 1.0 greater than this year's Visual CR.
- Current year's LCMS CR is 1.0 lower than this year's Visual CR.
- Last year's LCMS CR was deficient. This year's LCMS CR is sufficient.
- Last year's Visual CR was deficient. This year's LCMS CR is sufficient.

After a review is performed, the image reviewer determines which crack rating is most appropriate.

- If the LCMS crack rating is determined to be accurate, an "A" is entered as the crack source in the PCS Workbook.
- If the LCMS crack rating is not accurate (due to either missed or false cracking), the reviewer evaluates the visual crack rating.
  - If the reviewer disagrees with the initial visual crack rating, they will adjust it accordingly.
  - Once the visual crack rating is confirmed to be accurate, an "M" is entered as the crack source in the PCS Workbook.
- In some cases, the previous year's reported crack rating may be lower than both the LCMS and visual crack ratings. To avoid artificially increasing the crack rating, an "H" can be used as the crack source. In this case, the previous year's crack rating will be carried forward and reported as the new crack rating.

**TABLE 5**  
**NUMERICAL DEDUCTIONS FOR VISUAL CRACKING METHOD**

PERCENT OF PAVEMENT AREA AFFECTED BY CRACKING	CONFINED TO WHEEL PATHS (CW) <i>PREDOMINANT CRACKING CLASS</i>					
	I CRACKING		II CRACKING		III CRACKING (Including RAV & PT)	
	<u>CODE</u>	<u>DEDUCT</u>	<u>CODE</u>	<u>DEDUCT</u>	<u>CODE</u>	<u>DEDUCT</u>
0-5	<b>A</b>	0.0	<b>E</b>	0.5	<b>I</b>	1.0
6-15	<b>B+</b>	0.5	<b>F+</b>	1.5	<b>J+</b>	1.75
16-25	<b>B</b>	1.0	<b>F</b>	2.0	<b>J</b>	2.5
26-35	<b>C+</b>	1.25	<b>G+</b>	2.5	<b>K+</b>	3.5
36-50	<b>C</b>	2.0	<b>G</b>	3.0	<b>K</b>	4.5
51-75	<b>D+</b>	2.5	<b>H+</b>	4	<b>L+</b>	5.75
76-100	<b>D</b>	3.5	<b>H</b>	5.0	<b>L</b>	7.0

PERCENT OF PAVEMENT AREA AFFECTED BY CRACKING	OUTSIDE OF WHEEL PATHS (CO) <i>PREDOMINANT CRACKING CLASS</i>					
	I CRACKING		II CRACKING		III CRACKING (Including RAV & PT)	
	<u>CODE</u>	<u>DEDUCT</u>	<u>CODE</u>	<u>DEDUCT</u>	<u>CODE</u>	<u>DEDUCT</u>
0-5	<b>A</b>	0.0	<b>E</b>	0.0	<b>I</b>	0.0
6-15	<b>B+</b>	0.25	<b>F+</b>	0.5	<b>J+</b>	0.5
16-25	<b>B</b>	0.5	<b>F</b>	0.75	<b>J</b>	1.0
26-35	<b>C+</b>	0.75	<b>G+</b>	1.25	<b>K+</b>	1.5
36-50	<b>C</b>	1.0	<b>G</b>	1.5	<b>K</b>	2.0
51-75	<b>D+</b>	1.25	<b>H+</b>	1.75	<b>L+</b>	2.5
76-100	<b>D</b>	1.5	<b>H</b>	2.0	<b>L</b>	3.0

Notes: - Total percent of cracking is determined by combining Class I, Class II, Class III, Raveling and Patching.

Percentages for CW and CO are estimated separately, each representing 100% of its respective area.

Only the predominant cracking class will be recorded for CW and CO. When determining which crack class is predominant, combine percentages for Class III cracking with Raveling and Patching, then compare this value to percentages for Class I and Class II. The larger of these values is considered predominant.

CW Example: I = 10%, II = 12%, III = 6% Total = 28%

Predominant is Class II in the 36-50% category (code G – deduct 3.0)

CO Example: I = 10%, II = 6%, III = 6% Total = 22%

Predominant is Class I in the 15-25% category (code B – deduct 0.5)

Given the formula below:

$$\text{CRACK RATING} = 10 - (\text{CW} + \text{CO}).$$

$$\text{CRACK RATING} = 10 - (3.0 + 0.5)$$

$$\text{CRACK RATING} = 6.5$$

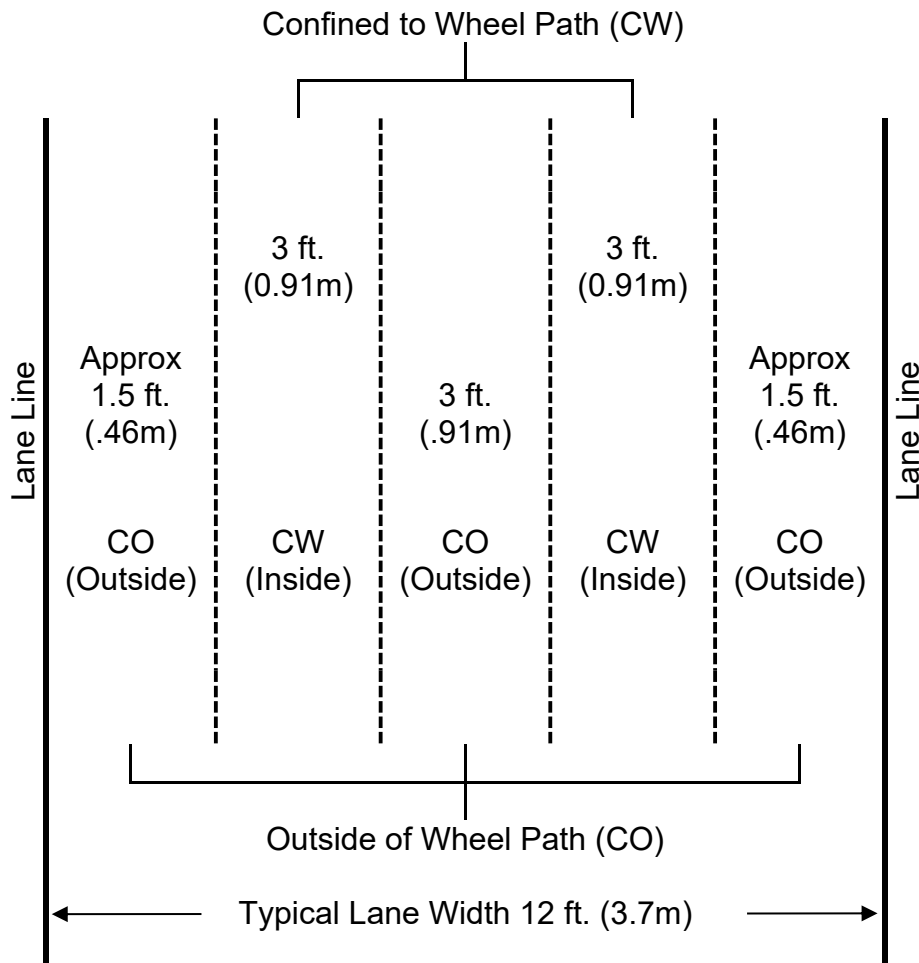

**FIGURE 1. WHEEL PATH DESIGNATION**

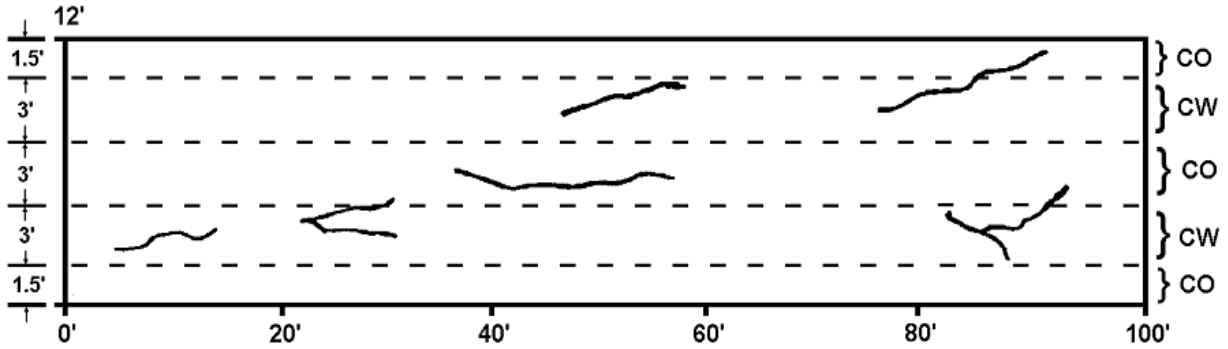

### AREA DIMENSIONS

$$\text{CW} = 56 \text{ ft. (17.07m)} \times 1 \text{ ft. (0.30m)} = 56 \text{ ft}^2 (5.20\text{m}^2) \\ \div 600 \text{ ft}^2 (55.74\text{m}^2) = 9\%$$

$$\text{CO} = 30 \text{ ft. (9.14m)} \times 1 \text{ ft. (0.30m)} = 30 \text{ ft}^2 (2.79\text{m}^2) \\ \div 600 \text{ ft}^2 (55.74\text{m}^2) = 5\%$$

**NOTE:** CW = Confined to Wheel Paths  
 CO = Outside of Wheel Paths  
 Class I cracks considered 1 ft. (0.30m) in width

**FIGURE 2. CLASS I CRACKING ESTIMATES**

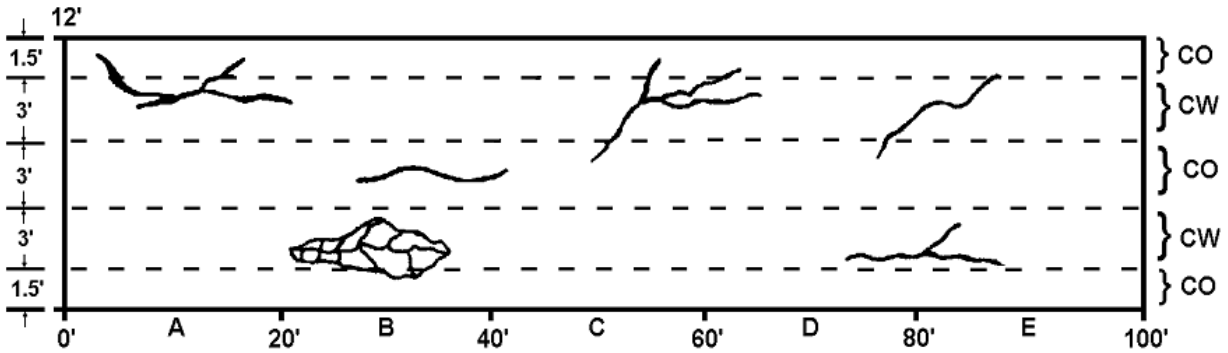

### AREA DIMENSIONS

**CW:** A = 21 ft<sup>2</sup> (1.95m<sup>2</sup>)  
 B = 30 ft<sup>2</sup> (2.79m<sup>2</sup>)  
 C = 14 ft<sup>2</sup> (1.30m<sup>2</sup>)  
 D = 16 ft<sup>2</sup> (1.49m<sup>2</sup>)  
 E = 21 ft<sup>2</sup> (1.95m<sup>2</sup>)

**CO:** A = 4 ft<sup>2</sup> (0.37m<sup>2</sup>)  
 B = 15 ft<sup>2</sup> (1.39m<sup>2</sup>)  
 C = 5 ft<sup>2</sup> (0.46m<sup>2</sup>)  
 D = 3 ft<sup>2</sup> (0.28m<sup>2</sup>)  
 E = 0 ft<sup>2</sup> (0m<sup>2</sup>)

**TOTAL** = 102 ft<sup>2</sup> (9.48m<sup>2</sup>)  
 ÷ 600 ft<sup>2</sup> (55.74m<sup>2</sup>)  
 = 17% of surface area

**TOTAL** = 27 ft<sup>2</sup> (2.51m<sup>2</sup>)  
 ÷ 600 ft<sup>2</sup> (55.74m<sup>2</sup>)  
 = 5% of surface area

**NOTE:** CW = Confined to Wheel Paths  
 CO = Outside of Wheel Paths  
 Single Cracks considered 1 ft. (0.30m) in width  
 Alligator Cracks considered as affected area  
 Block Cracks considered 1 ft. (0.30m) in width

**FIGURE 3. CLASS II CRACKING ESTIMATES**

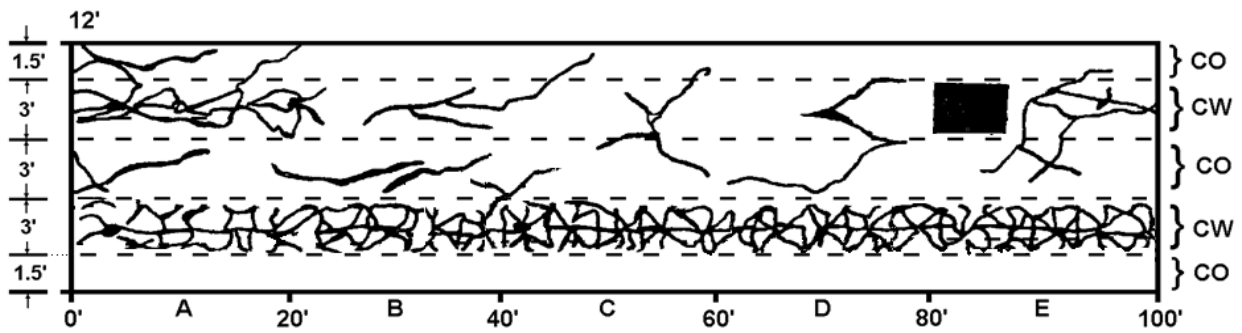

**AREA DIMENSIONS**

**CW:** A = 80 ft<sup>2</sup> (7.43m<sup>2</sup>)  
 B = 66 ft<sup>2</sup> (6.13m<sup>2</sup>)  
 C = 61 ft<sup>2</sup> (5.67m<sup>2</sup>)  
 D = 57 ft<sup>2</sup> (5.30m<sup>2</sup>)  
 E = 84 ft<sup>2</sup> (7.80m<sup>2</sup>)

**CO:** A = 38 ft<sup>2</sup> (3.53m<sup>2</sup>)  
 B = 24 ft<sup>2</sup> (2.23m<sup>2</sup>)  
 C = 15 ft<sup>2</sup> (1.39m<sup>2</sup>)  
 D = 17 ft<sup>2</sup> (1.58m<sup>2</sup>)  
 E = 14 ft<sup>2</sup> (1.30m<sup>2</sup>)

**TOTAL = 348 ft<sup>2</sup> (32.33m<sup>2</sup>)**  
 ÷ 600 ft<sup>2</sup> (55.74m<sup>2</sup>)  
 = 58% of surface area

**TOTAL = 108 ft<sup>2</sup> (10.03m<sup>2</sup>)**  
 ÷ 600 ft<sup>2</sup> (55.74m<sup>2</sup>)  
 = 18% of surface area

**NOTE:** CW = Confined to Wheel Paths  
 CO = Outside of Wheel Paths  
 Single Cracks considered 1 ft. (0.30m) in width  
 Alligator Cracks considered as affected area  
 Block Cracks considered 1 ft. (0.30m) in width

**FIGURE 4. CLASS III CRACKING ESTIMATES**

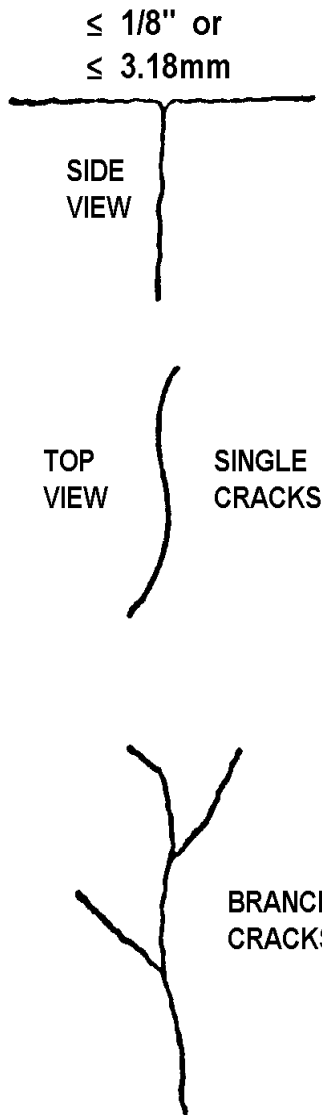

**FIGURE 5. CLASS I CRACKING CLASSIFICATION**

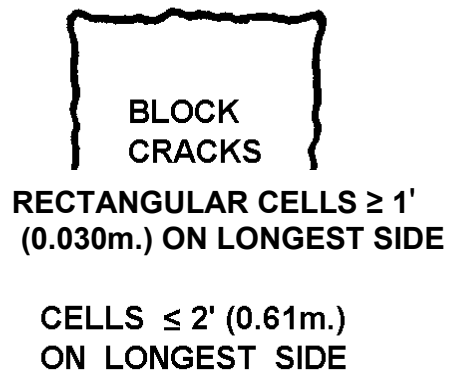
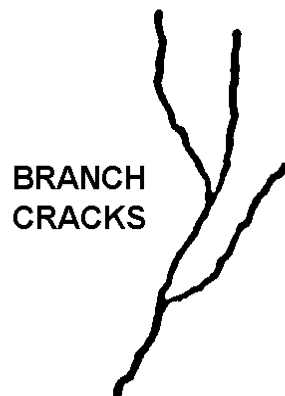
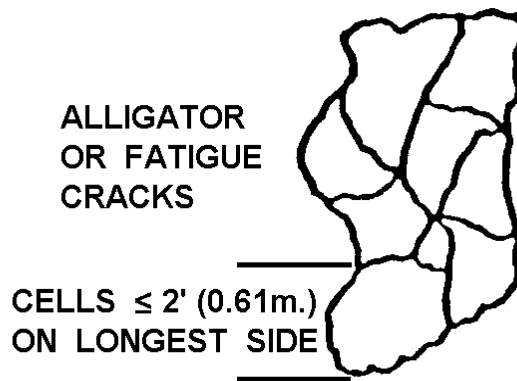
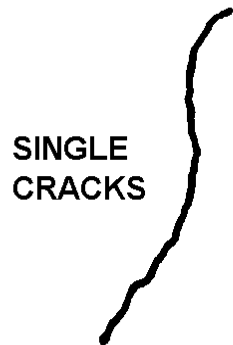
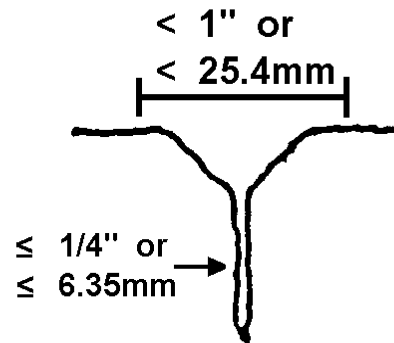
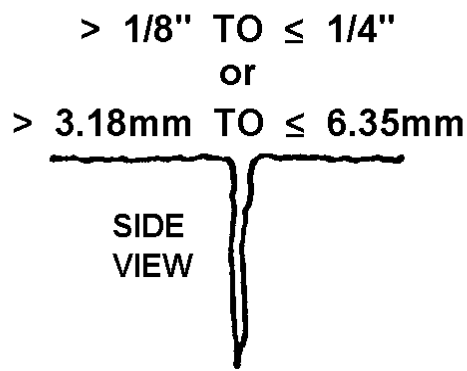
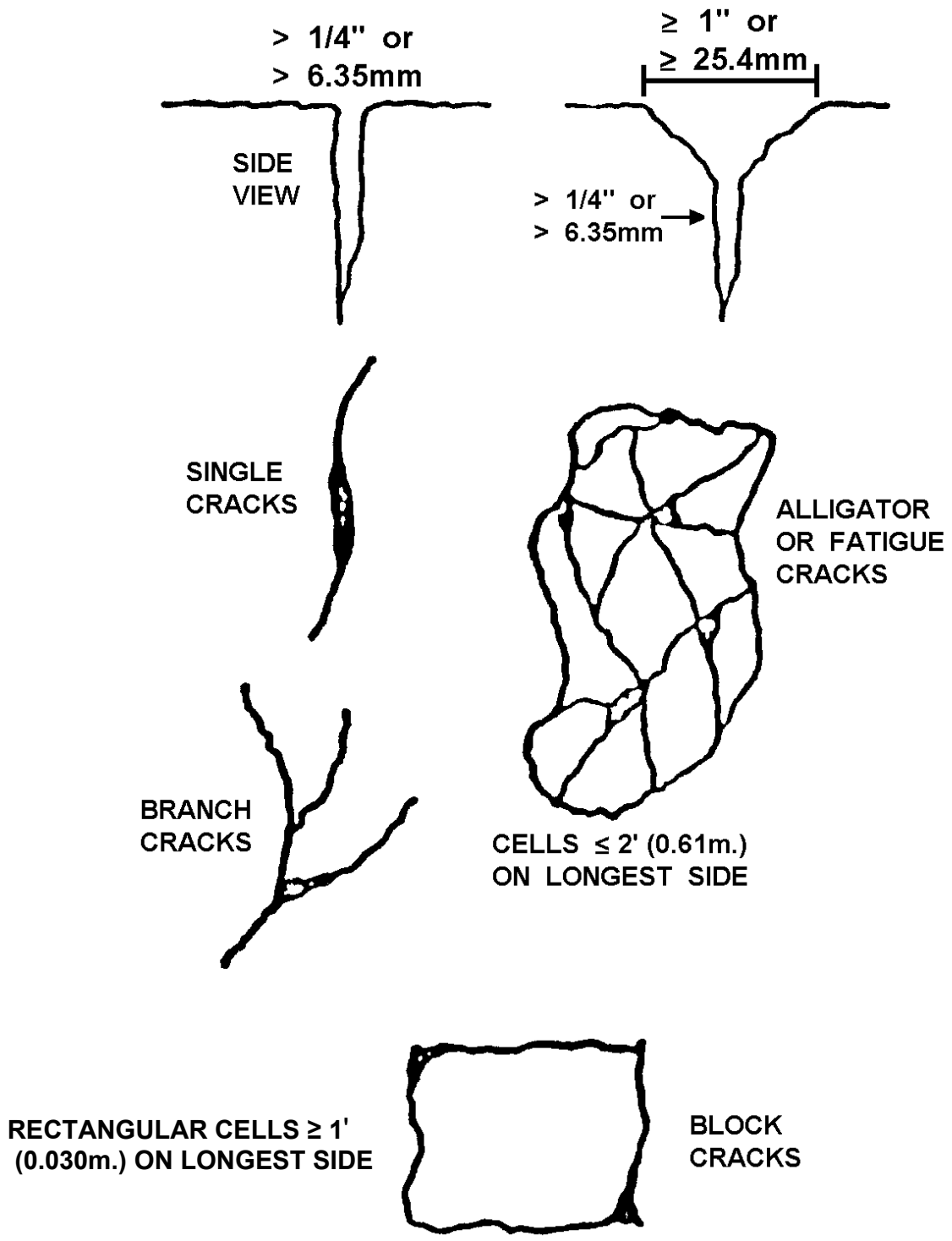

FIGURE 6. CLASS II CRACKING CLASSIFICATION



**FIGURE 7. CLASS III CRACKING CLASSIFICATION**



**FIGURE 8. CLASS I CRACKING**



**FIGURE 9. CLASS II CRACKING**



**FIGURE 10. CLASS III CRACKING**



**FIGURE 11. PATCHING**



**FIGURE 12. RAVELING**

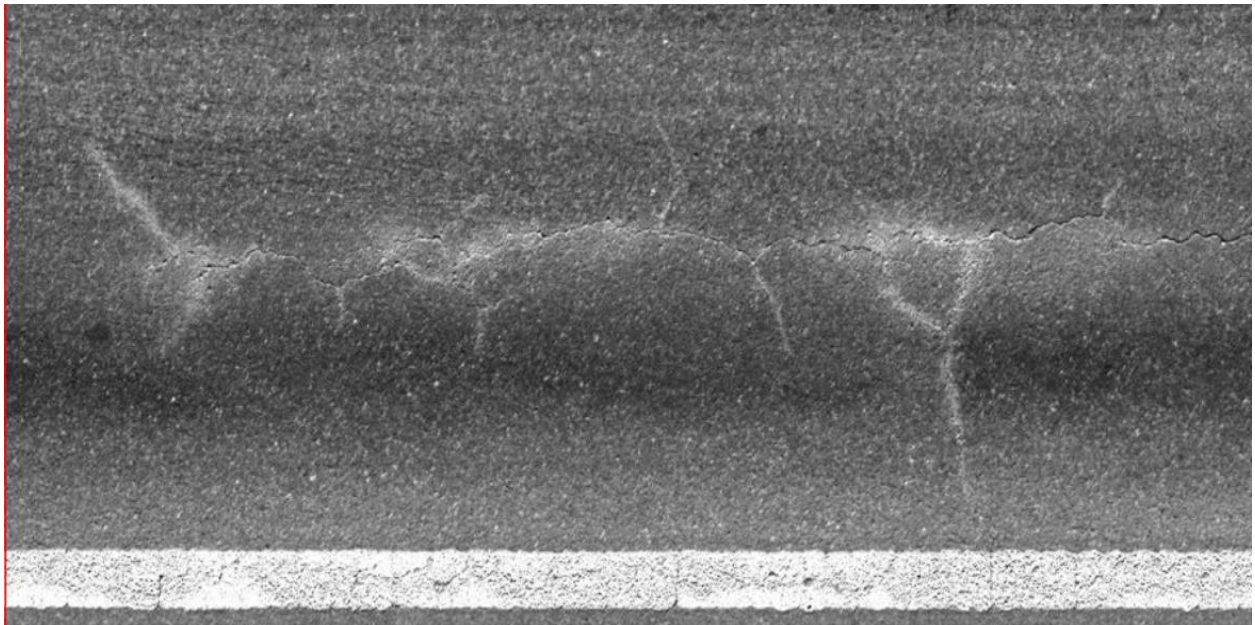

**FIGURE 13. PUMPING**

## **Rut Rating**

The LCMS calculates rutting by using high-resolution 3D laser scanning technology to capture detailed transverse profiles of the road surface, then analyzing the data to identify and measure the depth of depressions in the wheel paths. The rut depth is determined at various points across the road width, allowing for a comprehensive evaluation of rutting severity. LCMS rut depths are collected for reporting purposes. LCMS rutting data is not available in the field, therefore the inertial profiler is used to collect rutting in the field and compare to previous year's inertial profiler rut for rerun purposes. Both methods measure rut depths at highway speeds and record the average rut depth of the two-wheel paths for each section evaluated. The rut depth is then assigned a deduct value.

## **Rut Depth Check on New Pavement**

If the previous year's rut depth is  $\leq 0.040$  ft, the difference between the previous and current year's rut depths must be no greater than  $+0.08$  ft and no less than  $-0.05$  ft; otherwise, a rerun is required.

If the previous year's rut depth is  $> 0.040$  ft, the difference between the previous and current year's rut depths must be no greater than  $+0.10$  ft and no less than  $-0.11$  ft; otherwise, a rerun is required.

The profiler rut depth for sections of New Pavement must be less than 0.15 inches. If the profiler rut depth is greater than or equal to 0.15 inches, rerun the section to confirm data.

## **Rut Source Determination**

When LCMS data are loaded into the PCS Workbook, a rut source of "A" (LCMS rut depth) is automatically entered.

In some cases, the inertial profiler rut depth may be determined to be more appropriate. When this occurs, a rut source of "M" is manually entered into the PCS Workbook.

## Calculating Rut Rating

The Rut Rating is obtained by subtracting from ten (10) the deduct value associated with the LCMS rut depth (A) or inertial profiler rut depth (M). Rutting values are shown in **Table 6**. A Rut Rating of 10 indicates a pavement with only minor rutting.

**Rut Rating = 10 - Deduct Code**

**Example: Rut Depth 0.21 inches = Deduct of 2**

**Rut Rating = 10 - 2 = 8**

**TABLE 6  
RUTTING VALUES**

RUT DEPTH (IN)	RUT DEPTH (MM)	RANGE (IN)	RANGE (MM)	DEDUCT	RUT RATING
0	0	0.00 – 0.06	0.00 - 1.59	0	10
1/8	3.18	0.07 – 0.19	1.60 - 4.76	1	9
1/4	6.35	0.20 – 0.31	4.77 - 7.94	2	8
3/8	9.53	0.32 – 0.44	7.95 - 11.11	3	7
1/2	12.70	0.45 – 0.56	11.12 - 14.29	4	6
5/8	15.88	0.57 – 0.69	14.30 - 17.46	5	5
3/4	19.05	0.70 – 0.81	17.47 - 20.64	6	4
7/8	22.23	0.82 – 0.94	20.65 - 23.81	7	3
1	25.40	0.95 – 1.06	23.82 - 26.99	8	2
1 1/8	28.58	1.07 – 1.19	27.00 - 30.16	9	1
1 1/4 +	31.75	1.20 +	30.17 +	10	0

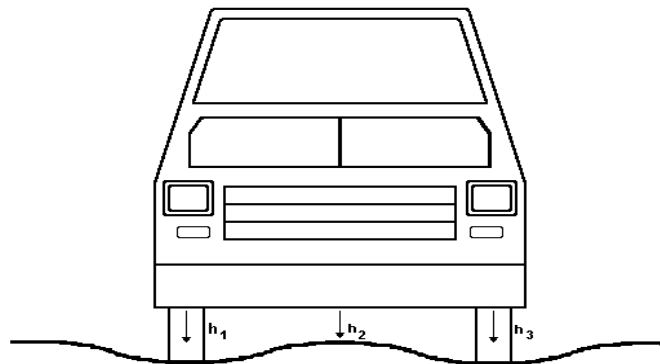

**FIGURE 14. INERTIAL PROFILER RUT DEPTH METHOD**

## Ride Rating

The longitudinal profile of each wheel path is measured at highway speeds by the inertial profiler, See **Figure 15**. Longitudinal profile data is collected at the smallest sample interval possible, usually less than one inch. The data is then processed using a 300-foot wavelength Butterworth high-pass filter. The longitudinal profile data is used to calculate the International Roughness Index (IRI) and Ride Number (RN).

IRI is a mathematical processing of the longitudinal profile generated by the profiler. IRI is a standard practice for computing and reporting road roughness (**ASTM E1926**). IRI is reported in units of inches per mile (in/mi) and is scaled with 0 being the smoothest and the upper limit being infinite. IRI values are rounded to the nearest whole number for reporting purposes. IRI is reported to the Federal Highway Administration (FHWA) annually. IRI is reported as the average of the left and right wheel paths. IRI data for each individual wheel path may be reported upon request.

Ride Rating (RR) is based upon a scale of 0 (very rough) to 10 (very smooth). IRI is used to determine RR. Refer to **Table 7** to convert IRI values to Ride Rating.

RN is also a mathematical processing of longitudinal profile measurements. RN is an estimate of subjective ride quality (**ASTM E1489**) and it is presented on a 0 to 5 scale that is not represented by any units. An RN of 5 represents a pavement that is perfectly smooth; however, this value is unachievable even with the smoothest of pavements. RN is a historical ride quality index that is no longer used but collected for information purposes only.

The following points are critical to the collection and reporting of Ride Rating:

1. The Ride Rating (RR) must not decrease more than 0.8 points or increase more than 0.4 points from the previous year's survey. For sections of New Pavement or New Construction, RR values must be 8.0 or more for projects with a test speed greater than or equal to 50 mph and 7.0 for projects with a test speed of less than 50 mph. Sections that do not meet the above requirements require reruns to be made according to rules in **Appendix A**.
2. Braking abruptly or accelerating rapidly (greater than 3 mph per second) produces invalid data. If this occurs the section must be re-tested.

Some of the pavement sections contain specific elements that are intentionally excluded from profiler ride data because the Department does not wish to include in the Ride Rating values. These are listed below:

- Bridges
- Railroad crossings
- Speed attenuating devices (rumble strips and speed bumps/humps)
- Rigid tractor crossings

Other elements determined to be valid when establishing Ride Ratings are:

- All crosswalks (brick or textured pattern)
- Manholes
- Rigid pavement intersections (less than 0.25 mile)
- Raised lettering and stop bars

**TABLE 7**  
**IRI to RIDE RATING VALUES**

<b>IRI Range</b>	<b>Ride Rating</b>	<b>IRI Range</b>	<b>Ride Rating</b>
1 – 12	10.0	162 – 166	5.5
13 – 28	9.2	167 – 170	5.4
29 – 32	9.1	171 – 175	5.3
33 – 34	9.0	176 – 180	5.2
35 – 37	8.9	181 – 185	5.1
38 – 39	8.8	186 – 190	5.0
40 – 42	8.7	191 – 195	4.9
43 – 46	8.6	196 – 200	4.8
47 – 50	8.5	201 – 206	4.7
51 – 54	8.4	207 – 212	4.6
55 – 58	8.3	213 – 218	4.5
59 – 62	8.2	219 – 224	4.4
63 – 66	8.1	225 – 230	4.3
67 – 70	8.0	231 – 236	4.2
71 – 74	7.9	237 – 242	4.1
75 – 78	7.8	243 – 249	4.0
79 – 82	7.7	250 – 256	3.9
83 – 86	7.6	257 – 264	3.8
87 – 89	7.5	265 – 271	3.7
90 – 93	7.4	272 – 278	3.6
94 – 97	7.3	279 – 285	3.5
98 – 100	7.2	286 – 293	3.4
101 – 104	7.1	294 – 300	3.3
105 – 107	7.0	301 – 310	3.2
108 – 111	6.9	311 – 318	3.1
112 – 115	6.8	319 – 327	3.0
116 – 118	6.7	328 – 337	2.9
119 – 122	6.6	338 – 345	2.8
123 – 125	6.5	346 – 354	2.7
126 – 129	6.4	355 – 362	2.6
130 – 133	6.3	363 – 371	2.5
134 – 137	6.2	372 – 373	2.4
138 – 140	6.1	374 – 385	2.3
141 – 144	6.0	386 – 397	2.2
145 – 149	5.9	398 – 406	2.1
150 – 152	5.8	407 – 533	2.0
153 – 157	5.7	>=534	1.0
158 – 161	5.6		



**FIGURE 15. Laser Crack Measurement System (LCMS) with Inertial Profiler**

## **IV. Flexible Pavement Condition Survey Field Workbook**

The Flexible Pavement Condition Survey Field Workbook is used by the rater in the field to record cracking data and any comments as well as any changes in mileposts or pavement type. Profiler data is imported into this electronic field workbook then the completed workbook is uploaded to the database. The information on pages 37 through 39 describes each data column on the Flexible Pavement Condition Survey Field Workbook.

**FIELD RATING FORM FOR FLEXIBLE PAVEMENT CONDITION SURVEY**

COLUMN TITLE	DESCRIPTION													
Test Date	Date Section Tested (Imported from Data)													
CNTY	<u>County number</u>													
SEC	State Roadway County <u>Section Number</u>													
SUB SEC	State Roadway County <u>Subsection Number</u>													
SR	<u>State Road Number</u> Example: 0008; 0369 NOTE: First Digit indicates: 1 - Alternate 2 - Business Example: 1008 or 2369													
US	<u>US Road Number</u> Example: 0027; 0301 NOTE: First Digit indicates: 1 - Alternate 2 - Business Example: 1027; 2301													
RDWY	<u>Roadway direction</u>													
TYPE	Pavement <u>Type</u>													
BMP	<u>Beginning Milepost</u> of the rated section.													
EMP	<u>Ending Milepost</u> of the rated section.													
SPEED	<table border="1"> <tr> <td rowspan="6" style="text-align: center;"><u>Uniform Test Speed</u> of rated section.</td> <td>Speed</td> <td>Code</td> </tr> <tr> <td>30 mph</td> <td>3</td> </tr> <tr> <td>40 mph</td> <td>4</td> </tr> <tr> <td>50 mph</td> <td>5</td> </tr> <tr> <td>60 mph</td> <td>6</td> </tr> <tr> <td>70 mph</td> <td>7</td> </tr> </table>	<u>Uniform Test Speed</u> of rated section.	Speed	Code	30 mph	3	40 mph	4	50 mph	5	60 mph	6	70 mph	7
<u>Uniform Test Speed</u> of rated section.	Speed		Code											
	30 mph		3											
	40 mph		4											
	50 mph		5											
	60 mph		6											
	70 mph	7												
LANES	Number of Thru <u>Lanes</u>													
RATED LANE	<u>Rated Lane</u>													
CW	Cracking <u>confined to the wheel path.</u> (Visual Rating)													
CO	Cracking <u>out of the wheel path.</u> (Visual Rating)													
CRK RATE	<u>Visual Crack Rating</u> (Calculated from CW and CO)													
PY_CR	Reported <u>Crack Rating</u> from previous year													
LT RAV	<u>Light Raveling</u>													

COLUMN TITLE	DESCRIPTION
MD RAV	<u>Moderate Raveling</u>
SV RAV	<u>Severe Raveling</u>
PT	<u>Patching</u>
CRK TYPE	<u>Crack Type</u>
SURFTYPE	<u>Surface Type</u>
VER	<u>Verification</u> results
COMBINED REMARKS	Combines <u>Comments</u> and <u>Remarks</u> Columns (Automatic)
LASER RUT	<u>Laser Profiler Rut</u> from Data
IRI	<u>IRI</u> value from Data
RN	<u>RN</u> from Data
RERUNS	Was <u>Rerun</u> Used?
COMMENTS	<u>Comments</u> from Technician or Office Staff
UNIT	<u>Unit Code</u>
UNIT TAG	<u>DOT Tag Number of Unit</u>
RATER 1	<u>Rater 1 Code</u>
RATER 2	<u>Rater 2 Code</u>
SYSTEM	<u>System code</u> <div style="display: flex; justify-content: space-around; margin-top: 10px;"> <div style="text-align: center;">1 - Primary</div> <div style="text-align: center;">2 - Secondary</div> </div> <div style="display: flex; justify-content: space-around; margin-top: 10px;"> <div style="text-align: center;">3 - Toll</div> <div style="text-align: center;">4 - Interstate</div> </div> <div style="display: flex; justify-content: space-around; margin-top: 10px;"> <div style="text-align: center;">5 - Turnpike</div> </div>
REMARKS	Entered using Toolbar “Remarks” button, select from list of Standard Remarks.

DISTRICT 1		DISTRICT 2		DISTRICT 3		DISTRICT 4		DISTRICT 5		DISTRICT 6		DISTRICT 7	
Charlotte	01	Alachua	26	Bay	46	Broward	86	Lake	11	Dade	87	Citrus	02
Collier	03	Baker	27	Calhoun	47	Indian River	88	Sumter	18	Monroe	90	Hernando	08
Desoto	04	Bradford	28	Escambia	48	Martin	89	Marion	36			Hillsborough	10
Glades	05	Columbia	29	Franklin	49	Palm Beach	93	Brevard	70			Pasco	14
Hardee	06	Dixie	30	Gadsden	50	St. Lucie	94	Flagler	73			Pinellas	15
Hendry	07	Gilchrist	31	Gulf	51			Orange	75				
Highlands	09	Hamilton	32	Holmes	52			Seminole	77				
Lee	12	Lafayette	33	Jackson	53			Volusia	79				
Manatee	13	Levy	34	Jefferson	54			Osceola	92				
Polk	16	Madison	35	Leon	55								
Sarasota	17	Suwannee	37	Liberty	56								
Okeechobee	91	Taylor	38	Okaloosa	57								
		Union	39	Santa Rosa	58								
		Clay	71	Wakulla	59								
		Duval	72	Walton	60								
		Nassau	74	Washington	61								
		Putnam	76										
		St. Johns	78										

**COUNTY NAME AND CODE NUMBER – ARRANGED BY DISTRICT**

# APPENDIX A

## Ride Rating Re-Run Procedure

**Tolerances from Last Year RR**

- RR must not decrease more than 0.8 from last year
- RR must not increase more than 0.4 from last year

**Tolerances for New Pavement RR**

- For Projects with a test speed  $\geq 50$  mph RR must be  $\geq 8.0$
- For Projects with a test speed  $< 50$  mph RR must be  $\geq 7.0$

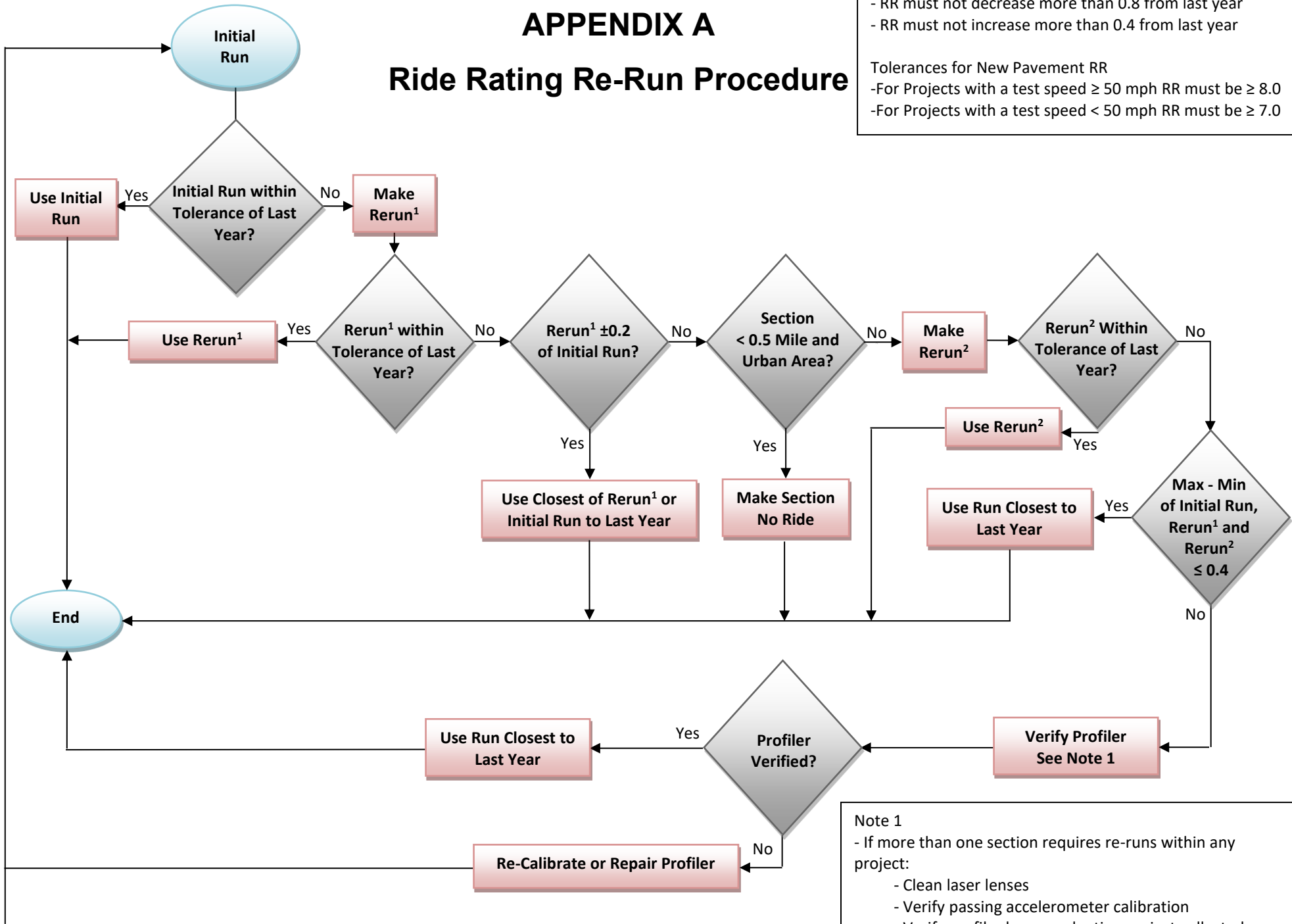

**Note 1**

- If more than one section requires re-runs within any project:
- Clean laser lenses
- Verify passing accelerometer calibration
- Verify profiler by re-evaluating project collected earlier that was accurate based upon last year's data.

# APPENDIX A

## Rutting Re-Run Procedure

Tolerances from Last Year's Rut		
Prev Year's Rut	Acceptable Difference (Current-Previous)	Action
≤ 0.40	Between -0.05 - +0.08"	No Action
	Outside Range Above	Rerun
> 0.40	Between -0.11 - +0.10"	No Action
	Out Range Above	Rerun
If New Pavement has a Rut Depth ≥ 0.15"		Rerun

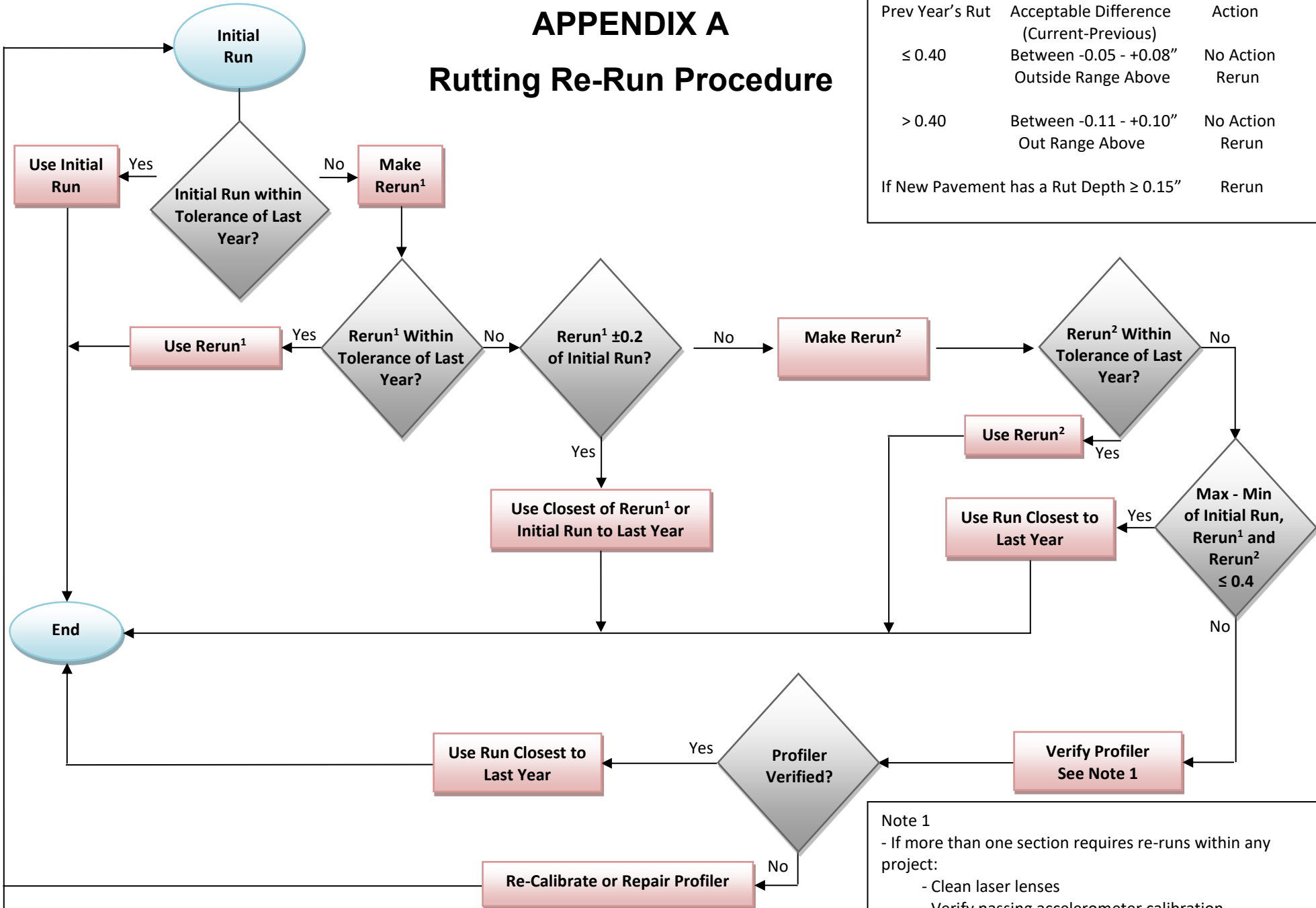

**Note 1**  
 - If more than one section requires re-runs within any project:  
 - Clean laser lenses  
 - Verify passing accelerometer calibration  
 - Verify profiler by re-evaluating project collected earlier that was accurate based upon last year's data.