

Volume I Section 3.1

DISTRICT MATERIALS ACTIVITIES FOR ASPHALT PAVEMENT CONSTRUCTION

3.1.1 PURPOSE

This document describes the activities necessary for District Materials and Research Office (DMRO) personnel who are involved in the production of asphalt mixtures and the construction of asphalt pavements on Florida Department of Transportation (Department) projects.

3.1.2 AUTHORITY

Section 334.048, Florida Statutes

3.1.3 REFERENCES

Code Of Federal Regulations (CFR), Federal-Aid Policy Guide (FAPG), Subchapter G - Engineering and Traffic Operations, Part 637 - Construction Inspection and Approval, Subpart B - Quality Assurance Procedures for Construction.

Florida Department of Transportation Standard Specification for Road and Bridge Construction (Specifications)

3.1.4 SCOPE

The principal users of this document include DMROs, District Construction Offices (DCOs), State Materials Office (SMO), and State Construction Office (SCO).

3.1.5 PROCEDURE

Contractor Quality Control (QC) specifications for asphalt construction outline the contractor's responsibility for all quality and process controls for production and placement operations. Project personnel (or in some instances, DMRO personnel specifically assigned to this function) are required to perform verification activities, which include sampling and testing; the monitoring of

certain portions of the producer/contractor's production and contractor's placement operations to assure compliance with their QC Plans, and the enforcement of all applicable *Specifications*.

DMRO personnel (specifically those personnel not directly involved in project level verification activities) are involved as an independent third party to ensure that the *Department's Quality Assurance Procedure for Construction (QAPC)* is functioning properly, to assure that the quality of the final product is acceptable, and to provide materials-specific technical assistance during the administration of the contract. These activities include 1) Independent Verification (IV) sampling and testing, 2) Resolution Testing (RT), 3) Independent Assurance (IA) and 4) technical support. The following outlines the actions necessary to implement these activities:

3.1.5.1 Independent Verification Activities

The purpose of an IV is to independently verify that the quality of the asphalt mixture meets the ***Specifications***. The project level verification testing is performed on split-samples for the asphalt mixture and the same roadway cores for density; and generally uses the Asphalt Producer's (herein referred to as the Producer), testing laboratory. The IV test then represents a safeguard to assure that: the asphalt mixture meets the ***Specifications***, the Producer's testing equipment is functioning properly, the QC tests are representative of the material being produced, and that there are no problems occurring within the QAPC system.

3.1.5.1.1 Asphalt Mixture

3.1.5.1.1.1 Sampling and Testing

The Producer should obtain IV samples at a minimum frequency of one sample per 4,000 tons of produced mix. The samples should be obtained at the required frequency based upon each individual mix design being produced. (On smaller projects, the frequency may be based on the total amount of asphalt mix being produced.) The samples should be obtained by the Producer under the direction and supervision of DMRO personnel. However, when scheduling conflicts arise, DMRO personnel may obtain the sample themselves. It is essential that the sample be obtained as soon as DMRO personnel arrive at the production facility to ensure the sample is representative of the mix being produced at that moment. The sample **cannot** be a split of the QC sample; it must be an independent sample to assure compliance with Federal Regulations. In situations

where DMRO personnel are not available to obtain the sample, the sample may be obtained by other Department personnel (Resident Asphalt Coordinator, Verification Technician, etc.). Once the asphalt mixture is sampled from the truck at the asphalt plant production facility or from the roadway, it should be boxed up, properly identified and sent to the appropriate laboratory for testing. The IV sample should consist of three boxes for a total sample size of approximately 35 pounds. The approximate size of each box should be 12" x 8" x 4". It is recommended, however, that enough material is sampled to provide the Producer with a Process Control (PC) sample and the Department with an IV check sample in the case of a non-comparison.

In addition to obtaining an asphalt sample from the production facility, DMRO personnel should also obtain an electronic summary of all QC and verification testing data from the VT on a regular basis, either by requesting a **Mix Design Summary Report** via the **Materials Acceptance and Certification system (MAC)**, in person, or via email.

Direct the Contractor to cut five roadway density cores preferably from the same day's production and subplot as the IV plant sample. If necessary, cores may be obtained from the next day's production as long as it is from the same subplot as the IV plant sample. The locations of the cores should be determined randomly, based on either tonnage or linear feet. The actual location of the cores shall be identified by either DMRO staff or the roadway VT with paint and the core stencil. A Department representative, either the roadway VT or DMRO staff, shall take possession of the cores at the roadway before the end of the shift they were cut. The DMRO staff will coordinate with the roadway VT to obtain the cores after the shift, so the chain-of-custody of the cores always remains with a Department representative. DMRO staff will trim the cores at the DMRO.

The samples should be tested at the DMRO laboratory or another accredited/qualified laboratory as approved by the District Materials and Research Engineer (DMRE). Each sample should be tested no later than the following working day and all concerned parties should be notified (including the Producer and/or Contractor) of the results within one working day following the completion of the testing.

IV samples should be reheated at the target roadway compaction temperature (as indicated on the mix design) for 1 ½ hours, reduced to the appropriate testing size and conditioned for one hour at the target roadway compaction temperature in a shallow, flat pan.

Note: Specimens for asphalt binder content and gradation do not need to be conditioned once the original sample has been reduced to the appropriate testing size.

Required testing of asphalt samples include the following:

- A) Determination of asphalt binder content and gradation. Samples should be tested in accordance with **FM 5-563** and **FM 1-T 030** for asphalt binder content (P_b) and gradation, respectively.
- B) Determination of air voids. The specimens should be tested in accordance with **AASHTO T 312** for the compaction of the Superpave Gyratory Compactor (SGC) specimens, **FM 1-T 166** for the compacted bulk specific gravity (G_{mb}), and **FM 1-T 209** for the maximum specific gravity (G_{mm}).

Note: Air void requirements do not apply to open-graded friction courses (FC-5) or Asphalt Treated Permeable Base (ATPB) mixes.

Note: IV samples should be tested at a location other than the Producer's laboratory. However, District personnel may, on occasion, use the Producers' SGC to compact IV samples when time and scheduling are critical. District personnel must assure that the SGC is properly calibrated and is functioning properly **prior** to using the Producer's equipment. To verify the equipment is functioning properly, duplicate samples should be taken and specimens compacted at the Producer's laboratory and at the DMRO laboratory. All comparison samples must be treated in a similar manner with respect to reheating time and compaction temperature. DMRO personnel will then make a comparison of the results of these tests to determine if they are favorable. After it has been determined that the Producer's equipment is properly calibrated and functioning properly, the Producer's equipment can then be used to compact the IV SGC specimens on occasion when time and scheduling are critical.

Note: G_{mb} values at N_{design} of the SGC specimens should be considered favorable if the DMRO and Producer's results are within 0.022 of each other.

- C) Determination of Density. Test roadway core samples for density in accordance with **FM 1-T 166**.

Note: Density requirements do not apply to FC-5 or ATPB mixes.

3.1.5.1.1.2 Evaluation of Data

Following the completion of the IV testing, enter the data into the Department's database. Request a Mix Design Summary Report using **MAC** and review the following data for trends and consistency between the IV, QC, and VT results: air voids (V_a), Voids in Mineral Aggregate (VMA), G_{mb} , heights of the SGC specimens, G_{mm} , P_b , gradation and in-place density (as applicable). Check for any errors or discrepancies in the test results to assure that the data is valid. Note if one set of data (QC, VT or IV) is consistently higher or lower than the other sets on any of the properties. Determine the possible assignable cause or causes for the inconsistency by reviewing all of the test data for that particular sample. For example, if the sample has low V_a , there should be an assignable cause behind the low V_a , such as high P_{-200} , high P_b , gradation problems, etc. If the test data is considered to be suspect, obtain additional samples and test as soon as possible. Production operations should not be limited, and evaluation of the material by delineation or an Engineering Analysis Report (EAR) should not be initiated for suspect data.

3.1.5.1.1.3 Specification Compliance

Once the data is determined to be valid, the material must also be checked to confirm it meets the **Specifications**, particularly the Master Production Ranges defined in **Specifications Sections 334 and 337**. If the material meets the **Specifications**, enter the information into the Department's database and notify the Producer (specifically the QC Manager or QC technician), Verification Technician, and Project Administrator (PA) of the results.

3.1.5.1.1.4 Failing Test Results

In the event the material fails to meet the **Specifications** then a comparison of the IV test results and the Contractor's (PC) test results, if available, will be made. If the comparison of the IV and PC results of the property in question meets the precision values as specified in **Specifications Section 334**, or the Contractor's test results are not available, the IV test results are determined to be valid. If the comparison of the results of the property in question does not meet the precision values for the material property in question, then the IV Check Sample is tested for that material property by a different IV technician than the IV technician who tested the first sample.

If the comparison between the first and second IV (IV and IV Check Sample (IVC)) test results does not meet the precision values for the material property in question, the first IV test results are considered invalid and no action shall be taken. If the comparison meets the precision values then the first IV test results are considered valid.

In the case of a valid IV failure, review all available information and then contact the QC Manager (or QC technician at the plant), Verification Technician, and the PA. Production operations should then be stopped in accordance with the requirements of **Specifications Sections 334 and 337**. (Specifically, DMRO personnel should notify the Producer that their asphalt production is out of the specified requirements and the Producer must take immediate action in accordance with their QC Plan to stop production.) However, operations at the plant should **not** be stopped if there is an obvious assignable cause to the problem that has already been corrected or can be corrected immediately (such as an equipment problem at the plant). In the event that corrective actions have already occurred, review any data that describes what the problem was and how it was resolved. If necessary, take additional samples as soon as possible to verify that the corrective actions taken by the Producer were successful.

In some instances, it may be useful to review other data, such as QC, VT and PC, prior to stopping production. However, it is important to note that the IV sample represents an independent assessment of the material's quality and may indicate other problems in the acceptance system, such as faulty test equipment, non-random sampling, or inaccurate QC data. In the event that corrective actions have already occurred, take additional samples as soon as possible to verify that the corrective actions taken by the Producer were successful. These follow-up samples may be obtained by personnel other than DMRO personnel provided that a random sample is obtained. PC samples, which are obtained in the same work shift following an IV sample, shall also contain enough material for a 3-way split (PC sample, IV sample, and IV check sample) should the contractor desire to use the PC data in a potential defective material evaluation. The use of this PC data in a defective material evaluation is also contingent on the PC sample and the verified IV sample comparing per the precision values specified in **Specifications Section 334**.

In all instances where plant operations are stopped due to failing IV test results, operations should remain stopped until the appropriate corrective actions are made and the problem is resolved to the satisfaction of the District Pavement Materials Engineer (DPME). Upon resuming production, the property that resulted in the shutdown should be verified

by DMRO personnel as soon as possible to ensure that the problem was adequately resolved. The Material Acceptance Review (MAR) process in MAC should be completed to document the failure.

Material failures should be handled as follows:

Low Air Voids at the Asphalt Plant: If V_a is below 2.30%, notify the Producer immediately and have the production of the mixture stopped (**Figure 1**).

High Air Voids at the Asphalt Plant: If V_a exceeds 6.00% and is less than or equal to 7.50%, look at the individual IV core densities, if available, and the QC core densities. If an individual core density is less than 89.50% of G_{mm} , notify the Producer immediately and have the production of the mixture stopped. If all of the individual core densities are $\geq 89.50\%$ of G_{mm} , notify the Producer of the high air voids and obtain another IV sample. In the event that the second IV sample also exceeds 6.00%, notify the Producer immediately and have production of the mixture stopped. If V_a exceeds 7.50%, notify the Producer immediately and have production of the mixture stopped. Evaluate any failing material in accordance with subarticle 3.1.5.4.1 and **Figure 2**.

Asphalt Binder Content: If P_b deviates more than 0.55% from the target for dense graded mixtures, review the volumetric data closely to determine the effect of the variation in P_b . If V_a is outside of the range of 3.00 – 5.00%, notify the Producer immediately and have the production of the mixture stopped. If V_a is within the range of 3.00 – 5.00%, notify the Producer of the test results and obtain another IV sample as soon as possible. In the event the second IV sample also deviates more than 0.55%, notify the Producer and have production of the mixture stopped (**Figure 3**). For FC-5 mixes, if the P_b deviates more than 0.60%, notify the Producer and have the production of the mixture stopped (**Figure 4**).

Roadway Density: If the average roadway density for the IV cores is below 89.50% of G_{mm} notify the Contractor immediately and, if necessary, stop the production and placement of the mixture. (**Figure 5**)

Gradation Failures: If the gradation results fall outside of the **Master Production Range** specified in **Specification Sections 334 and 337**, notify the Producer immediately and obtain another IV sample. In the event a second sample also deviates more than permitted in the **Master Production Range** on the same sieve, notify the Producer and discuss any necessary mix design revisions as well as any possible changes to

the QC Plan in order to prevent future gradation failures (**Figure 6**).

3.1.5.1.2 Asphalt Binder and Asphalt Mixture for Extraction

3.1.5.1.2.1 Sampling and Testing

Sampling and testing for all asphalt binders (unmodified and modified) and asphalt mixture for extraction by the State Materials Office will be in accordance with the minimum frequencies shown in the **Sampling, Testing, and Reporting Guide (STRG)**. Additional samples should also be obtained when requested by the SMO or when DMRO personnel suspect a related problem. Any material determined to be in non-compliance with the **Specifications** will be handled by the SMO and DMRO personnel.

3.1.5.1.3 Project Level Oversight

Although the following are the primary responsibilities of the project personnel, it is also the DMRO personnel's responsibility to ascertain that the basic QC and Verification activities are occurring as required.

At the asphalt production facility, DMRO personnel should ensure:

- A) The asphalt mixture temperature is being measured and verified.
- B) Delivery certifications are being supplied and checked for aggregate, asphalt binder, asphalt emulsions, mineral and/or cellulose fiber, and hydrated lime.
- C) The asphalt binder, asphalt emulsions, and liquid anti-stripping additives are on the **Approved Products List (APL)** and are referenced in the Producer's QC Plan.
- D) The warm mix technology being used is on the SMO's approved WMA list, if applicable.
<http://www.fdot.gov/materials/mac/production/warmmixasphalt/>
- E) Aggregate stockpiling and handling is consistent with the **Specifications** and the Producer's QC Plan.
- F) The test methods are being performed properly, and all testing equipment is properly calibrated and maintained in compliance with the

manufacturer's recommendations.

- G) The asphalt QC samples are being obtained on a random basis and that all samples are being clearly identified and stored properly.
- H) Roadway cores are clearly identified and stored properly.
- I) All test data is being entered into the Department's database (MAC) and the data appears to be accurate and in compliance with the **Specifications**.
- J) QC and VT plant testing and other necessary documentation should be completed and recorded in the Department's database within the prescribed time frame.

At the *roadway*, DMRO personnel should determine:

- A) The mix temperature, mix spread rate, cross-slope, milling cross-slope, and tack spread rate are all being measured and verified as required.
- B) Roadway cores are being taken on a random basis.
- C) QC and VT Roadway reports are being completed in the prescribed timeframe.
- D) The final pavement surface has an acceptable ride quality, uniform texture with well-constructed longitudinal and transverse joints.
- E) Prime coat and tack coat products are on the Department's Approved Product List (APL).
- F) A copy of the Bill of Lading representing the prime coat or tack coat material in the distributor tank must in the truck and be available at all times.

Any problems identified during the reviews should be brought to the attention of the QC Manager and PA/Resident Asphalt Specialist, as appropriate.

3.1.5.2 Resolution Testing

Prior to testing Resolution samples, the QC and VT data from the property

or properties in question should be reviewed to confirm that the material meets the requirements (as defined in the **Specifications**) for Resolution Testing. If determined necessary, the Resolution samples should be handled as follows:

Reheat the Resolution samples at the target roadway compaction temperature (as indicated on the mix design) for 1½ hours, reduce to the appropriate testing size in accordance with **FM 1-T 168**, and then condition for one hour at the target roadway compaction temperature in a covered, shallow, flat pan.

Note: Specimens for asphalt binder content and gradation do not need to be conditioned once the original sample has been reduced to the appropriate testing size.

Test the samples in accordance with the following:

FM 5-563 - Asphalt Binder Content

FM 1-T 030 - Gradation

AASHTO T 312 - Compaction of the SGC specimens

FM 1-T 209 - Maximum Specific Gravity

FM 1-T 166 - Bulk Specific Gravity of roadway core samples and SGC specimens

The Resolution results shall then be entered into the Department's database for comparison. Use the Between-Laboratory Precision Values in the **Specifications** to compare the Resolution Test results for all of the sublots of the Lot for the property or properties in question with the corresponding QC results. If all of the Resolution Test results compare favorably with the QC test results, then the QC results are considered verified, and should be used for payment. The Resolution samples shall then be approved in the database with the proper disposition.

If **any** of the Resolution test results do not compare favorably with the QC results, all of the Resolution Test results are to be used for payment for the property or properties in question. The DMRO will notify the PA that the Resolution test results have been entered into the Department's database and direct him/her to perform the Comparison Package Resolution to determine the CPF. The PA will deduct the Resolution testing costs from

the Contractor's monthly estimate if the QC results are not upheld. Testing costs can be located on the SMO website at

<http://www.fdot.gov/materials/quality/programs/qualitycontrol/contractor.shtm>

A follow-up evaluation of the QC/VT testing equipment and procedures should also be scheduled by DMRO personnel to determine the source of the invalid comparison between QC and VT, which initiated the Resolution testing.

3.1.5.3 Independent Assurance

In addition to the systems-based approach to Independent Assurance (IA), as defined in **Materials Manual (MM) Section 5.5**, comparison tests should also be run on split samples as deemed necessary by DMRO personnel. The purpose of these tests is to verify that the Producer's testing equipment is functioning properly and that the testing procedures are being performed correctly. Project specific IA comparisons can be used to identify and correct project related testing problems, and can be used as a method of meeting district-specific goals or targets from the IA Program.

Split samples should be taken to evaluate both the QC and VT procedures, as one set of samples (IA/QC/VT) or as an individual assessment for each technician (IA/QC or IA/VT). The Producer should be directed to sample the material and split it into the appropriate number of samples. DMRO staff should provide detailed instructions to all parties involved regarding how the samples are to be reheated, reduced to sample size, conditioned and tested. In order to minimize variability, all samples must be treated in a similar manner prior to testing.

Test results should be compared based on the Between-Laboratory Precision Values given in **Specifications Section 334**. A copy of the comparison results should be forwarded to the QC Manager/QC Technician and the VT. IA personnel will promptly compare and document test results to support the Qualification Performance Report (QPR) described in **MM Section 5.5.6.2**. Any test results that do not compare favorably should be investigated thoroughly to determine the source of the problem. Follow-up activities should include observations (checklists are located at the following URL:

<http://www.fdot.gov/materials/quality/programs/independentassurance/cheklist/index.shtm> and a check/verification of the equipment calibrations. If necessary, additional technical support can be solicited from the SMO. Recurring problems should be addressed through **MM Section 5.5**.

3.1.5.4 Technical Support

3.1.5.4.1 Assessment of Defective Materials

When instances of defective materials or non-compliance with the QC Plan or **Specifications** occur, DMRO personnel will assist in assessing the suitability of the material to either remain in place or be removed and replaced. Typically this involvement will consist of input on the EAR submitted by the Contractor, or in some situations, may result in the DMRO personnel performing a forensic investigation. For further guidance see **Construction Project Administration Manual (CPAM) Section 5.8**.

When a failure occurs on a project, and the Contractor proposes the material remain in-place, they will propose the use of an EAR or delineation to evaluate the failing material. (Typically, an EAR is used for an air void failure and delineation is used for all other types of failures.) When DMRO personnel receive the EAR/delineation request, they will review the information regarding the failure and make one of the following recommendations: 1) remove and replace the material without an EAR/delineation, 2) leave the material in place without an EAR/delineation, or 3) permit the use of an EAR/delineation. When an EAR or delineation is authorized, DMRO personnel must ensure that the appropriate characteristics are evaluated to determine the disposition of the defective material. In some instances it may be appropriate for DMRO personnel to recommend additional or alternative tests to be performed.

No work shall commence until a scope for the EAR/delineation is submitted by the Contractor and reviewed and approved by the DMRO. When reviewing the scope, the following should be considered:

1) Engineering Analysis Reports:

The EAR firm must have a representative onsite during coring to supervise the process and take delivery of the cores for further testing. However, when agreed upon by the Engineer, a Department representative may oversee the coring process per the coring plan developed by the EAR firm and may take temporary possession of the cores until the EAR firm can

retrieve them. The Contractor should not take possession of the cores. The laboratory performing the testing must be AMRL or CMEC accredited, or possess other independent inspection program accreditation acceptable to the Engineer and equivalent. The EAR firm must perform the testing at its own lab (not the Contractor's laboratory) under the responsible charge of the PE signing and sealing the EAR. As an option, the EAR firm can use another accredited lab (not the Contractor's lab or other lab performing QC work for the Contractor) provided those test results are signed and sealed by the PE in responsible charge of the laboratory or in responsible charge of the technician performing the testing. Additionally, the EAR must then be signed and sealed by the PE of the EAR firm.

The following guidelines should be used when reviewing a proposed EAR scope based on the particular failure, to determine if any areas require removal and replacement.

Low air voids: Evaluate density (in the wheel paths), asphalt binder content, and/or gradation. The pavement should be opened to traffic for as long as possible prior to coring to allow for potential densification. However, since the pavement will likely not have been opened to traffic for very long prior to the analysis and will not have adequate time to further densify under traffic, density alone should not be considered a good indicator of performance. Consequently, the analysis should focus on those characteristics that caused the low air voids (high binder, high P-200, etc.,) as well as density.

2) Delineation:

The Contractor will typically obtain the cores and perform the required testing. A Department representative (typically the Roadway VT) will observe the coring operation, ensuring the cores are taken from the correct locations and labeled correctly. A Department representative (typically the Plant VT) will observe the trimming, labeling, and testing of the cores to assure conformity with Department test methods and that the correct test results are reported.

The following guidelines should be used when reviewing a proposed delineation scope based on the particular failure, to determine if any areas require removal and replacement:

A) High Air Voids (Fig. 2):

- 1) If air voids $> 6.0\%$ and $\leq 7.5\%$ and all subplot cores (includes QC and IV cores if applicable) are $\geq 89.5\%$ Gmm, no further

- action is required.
- 2) If air voids $> 6.0\%$ and $\leq 7.5\%$ and there are failing density core(s), then delineate for density between passing density tests (QC and/or IV) and remove and replace any material with failing density.
 - 3) If air voids $> 7.5\%$, then delineate the subplot between passing tests (QC, PC and/or IV) and remove and replace any material with failing density or AC.
- B) Low roadway density (Fig. 5): Evaluate in-place density when the subplot density is below 89.50% Gmm. Lay out all existing core data, including station and offset, for the subplot in question, and if necessary, the adjoining sublots. The pavement should be evaluated from passing density test result to passing density test result, with the low density pavement located between the passing test results. Evaluation of low density material can encompass pavement outside of the subplot in question, but the evaluation limits should not cross outside of the Lot containing the low density material. When determining the limits for evaluation, one item to consider is production days. It is possible the low density could be related to a production issue that occurred on one day but not on other days. Cores should be obtained next to previous core locations which had failing density results (less than 89.50% Gmm). Typically, cores are obtained between the wheel path, especially when the roadway has been open to traffic, but some judgment is needed, as it is possible that the center of the lane had extra compaction due to roller overlap. Utilize the corresponding QC or IV subplot Gmm value in density calculations, depending on the source of the failure. If the Gmm for the failing subplot is itself in question, then the delineation scope should include testing the Gmm of the remaining boxed mix of the subplot or the roadway cores from the area in question. Areas represented by delineation cores with failing density results will be removed and replaced. If all of the delineation cores pass the minimum density requirements, no material would be removed and replaced.
- C) High asphalt binder content (Figs. 3-4): Evaluate production and in-place density (in the wheel path and between the wheel paths), asphalt binder content, and possibly gradation. The pavement should be opened to traffic for as long as possible prior to coring to allow for potential densification. For FC-5 mixes, evaluate the in-place binder content, gradation, and field permeability. In addition,

the pavement should be observed for any signs of bleeding or flushing.

- D) Low asphalt binder content (Figs 3-4): Evaluate production and in-place density (between wheel paths), asphalt binder content, and possibly gradation. For FC-5 mixes, evaluate the in-place binder content, gradation, and signs of raveling.
- E) Gradation (Fig. 6): Evaluate production and in-place density, asphalt binder content and/or gradation. For FC-5 mixes, evaluate the in-place binder content, and gradation.
- F) Bond strength testing for slippage investigations during construction: When pavement slippage occurs during construction and/or poor construction practice has occurred (ex: paving in the rain, paving over a dirty surface, applying too low or too high of a tack rate, poor quality tack material, etc.) evaluate the pavement by obtaining roadway cores and testing in accordance with **FM 5-599**. For areas where slippage has already occurred, cores should be obtained in an outward direction from the slippage area in an increment of approximately 50 ft., but this can be adjusted based on engineering judgment. For areas of poor construction practice but which may or may not have experienced slippage, evaluate the areas as documented by project staff. Use a bond strength value of 80 psi as a minimum limit for a single core when evaluating pavement slippage to determine areas of removal and replacement. When pavement slippage occurs after final acceptance of the project but during the 3-year warranty period, remove the slipped area(s) plus 50 ft. either side of the slipped area(s).

For EAR or delineation, the acceptable limits for the test results typically will be the Master Production Range as defined in **Specification Sections 334 and 337**. However, engineering judgment should be used in all cases. Details of a particular situation can vary greatly for the same failure type.

Once the EAR or delineation is completed and submitted to the PA, it is forwarded to DMRO personnel for their review and concurrence on the disposition of the material per **CPAM 5.8**. For further clarification on the disposition, and for statewide uniformity, contact staff at the SMO.

3.1.5.4.2 Mix Design Revisions

Mix design verification is the primary responsibility of the SMO. Revisions

to verified mix designs are the joint responsibility of DMRO and SMO personnel. Prior to a revision request being submitted to the SMO, DMRO personnel should verify that the mix design will meet the production volumetric requirements (**Specifications Section 334**) after the changes have been made.

An e-mail or written request in the Department's database from DMRO staff listing the mix design number, the proposed changes to the design, and the effective date will be required for all revisions. A copy of the Producer's revision request should also be included. The revision request can be attached to the mix design revision that was created in the Department's database.

Additional information will be required for each type of revision as shown below.

A) Asphalt Binder:

1. Any revision of optimum asphalt binder content (maximum of $\pm 0.3\%$ from the "A" version of the design) will require supporting field data at or near the proposed binder content to ensure the volumetric requirements are being met, including verification that the VMA of the as-produced mix has not dropped more than 1% below the minimum.
2. A recalculation of the maximum specific gravity (G_{mm}), at the proposed optimum binder content must also be submitted.
3. A change in optimum binder content greater than 0.3% will require re-verification of the mix design.
4. A change to or from a modified asphalt binder (i.e., PG 76-22) will require supporting production or laboratory data at the proposed binder content to ensure volumetric requirements are being met.

B) Reclaimed Asphalt Pavement (RAP):

The following information should be provided to SMO personnel:

1. Stockpile number, plant number and extraction data - including asphalt binder content, gradation, maximum specific gravity and aggregate bulk specific gravity (G_{sb}).

2. Completed approval letter (**Figure 7**) stating that the stockpile has been visually inspected by DMRO personnel and is to be approved for use.
3. The contractor shall provide approximately 35 lb of RAP to the SMO for a Gsb comparison. If the multi-laboratory difference is greater than 0.050 but less than 0.060, the Contractor shall have the option to use the SMO's Gsb value for the approved stockpile or choose to send the SMO a new sample to re-test.

The SMO staff will then input all the RAP information into the Department's database.

Note: If there is a significant change in the characteristics of the RAP material, it may necessitate a new design or re-verification of the original design by the SMO.

C) Component Revisions:

1. Provide the results received from a minimum of six gradation QC tests taken from the aggregate stockpile.
2. Include the Terminal Number, Pit Number, FDOT Code, Type of Material and Producer, as applicable.

Note: A new mix design will be required for **any** substitution of an aggregate product with a different code, unless approved by staff at the SMO Office.

D) Sand Revisions:

The gradation, G_{sb} and source (i.e., plant number, location, etc.) should be provided. A change to the sand source may require a new design or re-verification of the existing design.

E) Traffic Level Revisions:

Any traffic level revision that involves a change in gyrations for an existing mix design will require new pre-batched aggregate samples to be sent to the State Material Office for verification testing. In essence, these types of revisions will be treated as new mix designs.

F) Gradation Revisions:

1. If revising the gradation on any sieve above the No. 8 sieve, supporting data verifying that the stockpile gradation has changed must be included.
2. Refer to **Specification Section 334** for the Limits for Potential Adjustments to Mix Design Target Values.

G) Updates Due to Mix Design Expiration:

Any updates for expiring mix designs will require supporting data to verify that the mix design will meet the volumetric requirements (i.e., updated back page of the mix design). Mix designs are valid for a period of three years. In addition, FC-5 mix designs must be re-verified by the SMO every three years.

H) Liquid Anti-Strip:

All liquid anti-strip used in asphalt mix designs must be listed on the **APL**.

I) Warm Mix Designs

Transfer requests of a hot mix asphalt design to a warm mix asphalt design may require re-verification depending on the technology being used. All warm mix transfers will require a new design number.

3.1.5.4.3 Technical Assistance

DMRO personnel are expected to: 1) provide technical assistance to project and Contractor personnel; 2) observe and evaluate all quality-related facets of the asphalt production, testing, and paving operations; 3) advise project personnel and the Contractor of any problems that are identified; and 4) recommend corrective action where such actions are deemed necessary for proper Specification compliance.

3.1.5.4.4 QC Plan Approval and Compliance

DMRO personnel play a role in the review and approval of the Producer's QC Plan, as defined in **MM Section 5.6**.

3.1.5.4.5 Laboratory Qualification

DMRO personnel play a role in the review and approval of the Producer's testing laboratory, as defined in **MM Section 5.7**.

3.1.6 TRAINING

All personnel who are involved in the activities outlined in this procedure are required to hold valid CTQP Asphalt Qualifications. If the principal duties of the IV personnel pertain to the roadway, **Asphalt Paving Levels I and II** Qualifications are required. If the principal duties of the IV personnel pertain to the plant, **Asphalt Plant Levels I and II** Qualifications are required. If the principal duties of the IV personnel pertain to the both, **Asphalt Paving Levels I and II** and **Asphalt Plant Level I and II** Qualifications are required. These qualifications are to ensure that these personnel have a thorough knowledge of the basics of asphalt production, placement, testing and the Specifications.

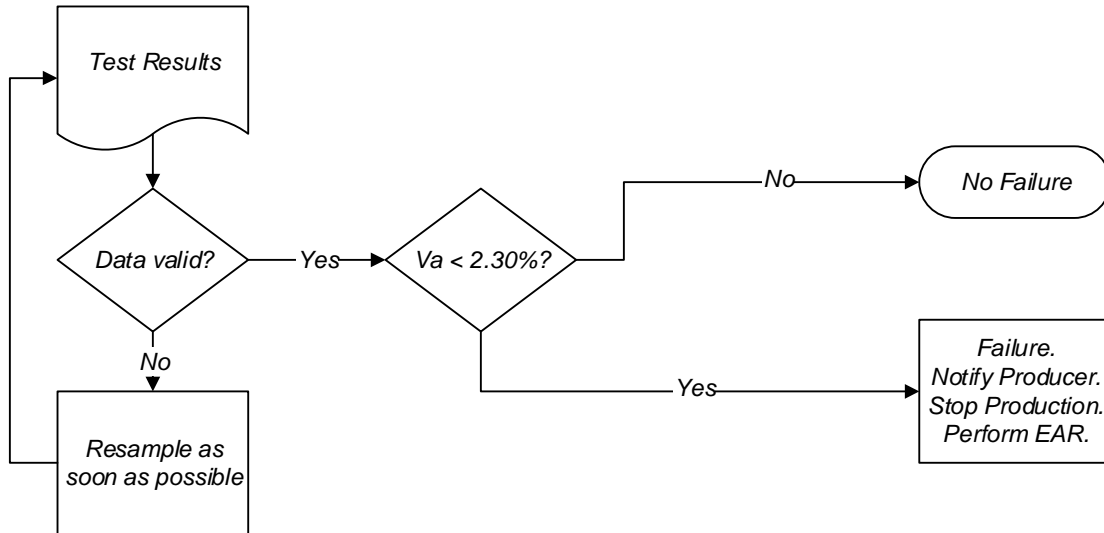

Figure 1 Low Air Voids at the Asphalt Plant – Dense Mixes

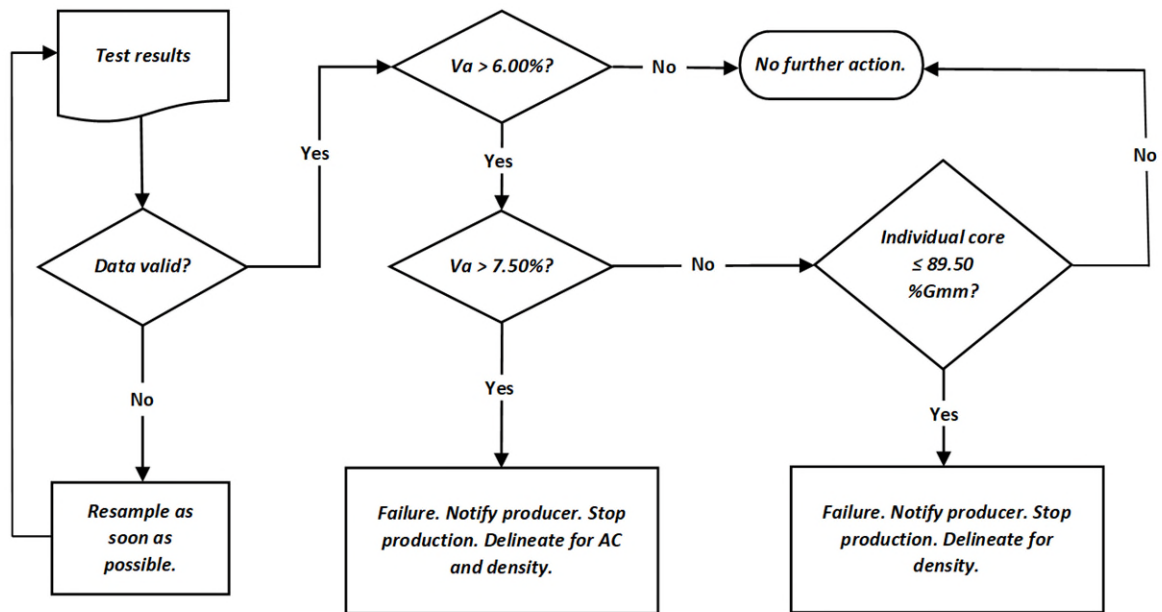

Figure 2 High Air Voids at the Asphalt Plant – Dense Mixes

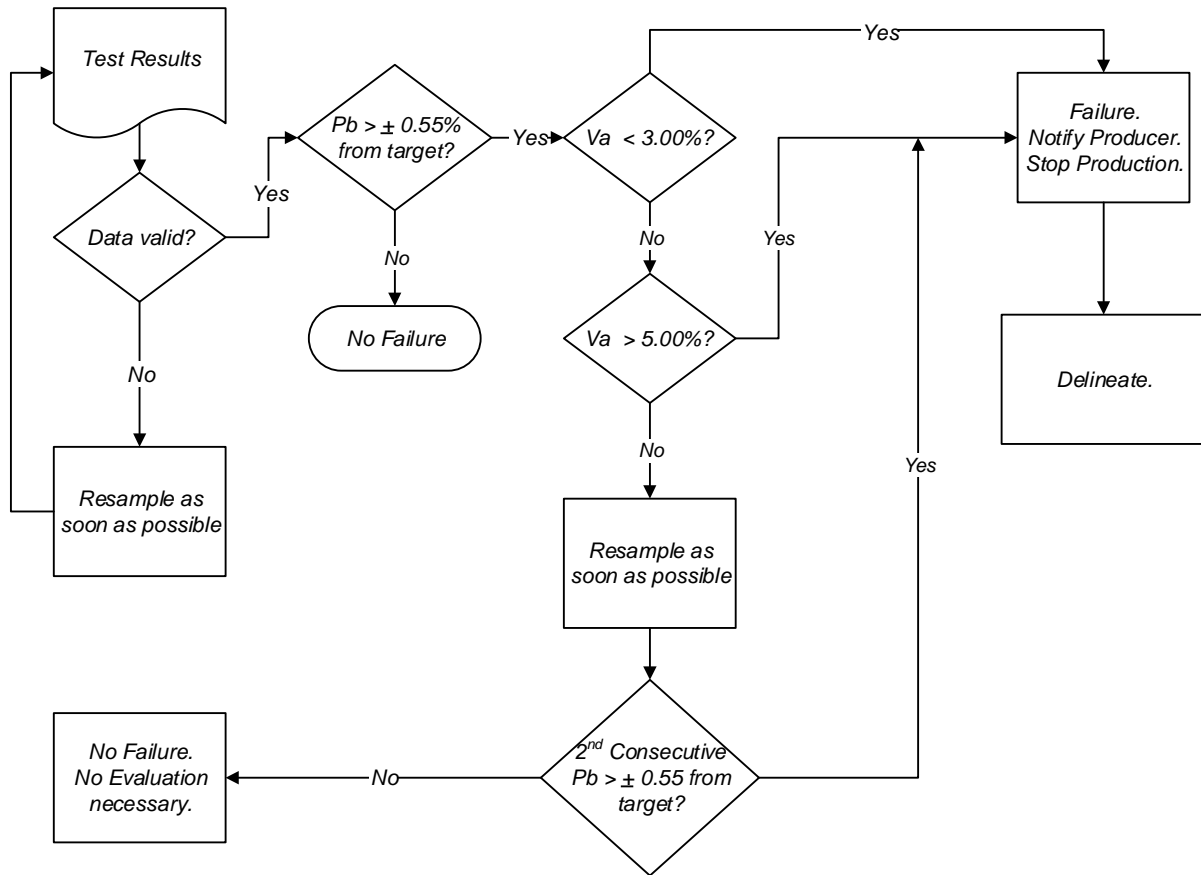

Figure 3 Asphalt Binder Content (P_b) – Dense Mixes

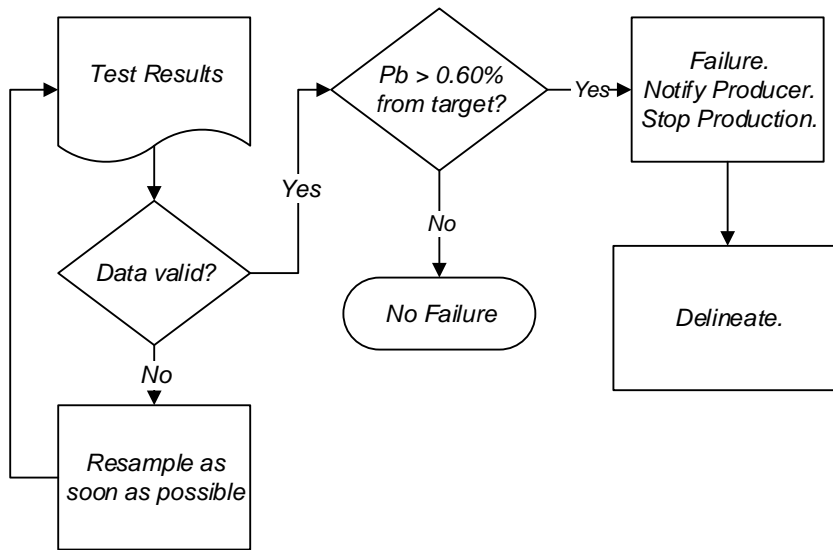

Figure 4 FC-5 Asphalt Binder Content (P_b)

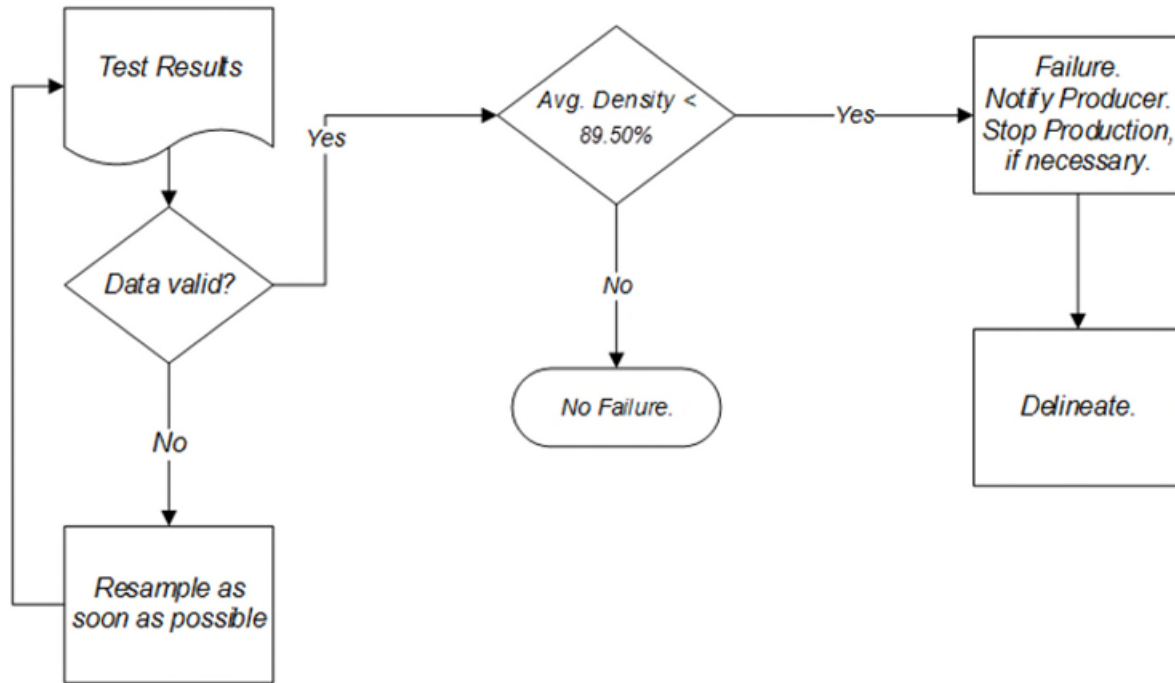

Figure 5 Roadway Density

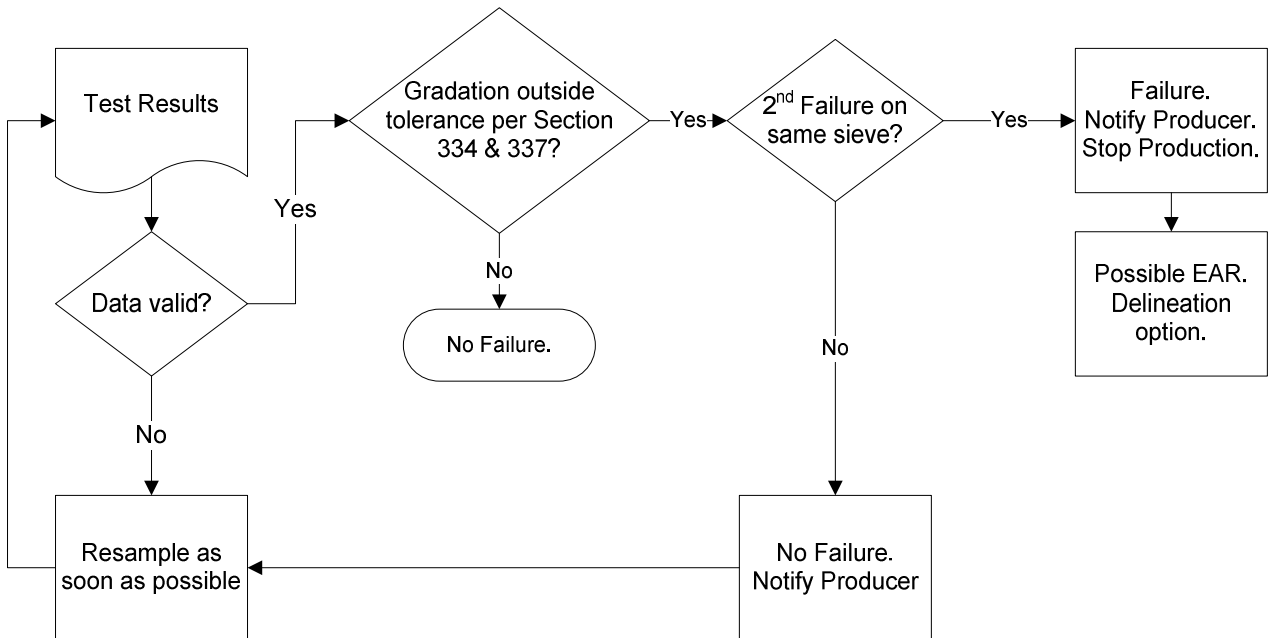

Figure 6 Gradation Failures



Reclaimed Asphalt Pavement Approval Letter
 Florida Department of Transportation

ENTER DISTRICT OFFICE NAME
 ENTER OFFICE ADDRESS
 PHONE NUMBER / FAX NUMBER

Contractor Name:			
Material Description:		Quantity Represented:	
Plant Number:		Stockpile Number:	
Inspected By:		Inspection Date:	
Approved By:		Approval Date:	

At the request of , the ENTER DISTRICT OFFICE NAME conducted a visual inspection of the subject stockpile of reclaimed asphalt pavement (RAP) material and reviewed the stockpile's test data.

The results of this inspection and review indicate that the RAP material is suitable for use as a component in asphalt mixtures. The subject stockpile represents approximately tons of RAP.

Refer to Section 334-2.3.3 of the Specifications for the rules and requirements regarding sampling and testing of Continuous and Non-Continuous stockpiles.

Properties																																	
<table border="1" style="width: 100%;"> <tr><td style="text-align: center;">% AC:</td></tr> <tr><td style="height: 20px;"></td></tr> <tr><td style="text-align: center;">Viscosity:</td></tr> <tr><td style="height: 20px;"></td></tr> <tr><td style="text-align: center;">Gmm:</td></tr> <tr><td style="height: 20px;"></td></tr> <tr><td style="text-align: center;">% Absorption</td></tr> <tr><td style="height: 20px;"></td></tr> <tr><td style="text-align: center;">Gsb:</td></tr> <tr><td style="height: 20px;"></td></tr> </table>	% AC:		Viscosity:		Gmm:		% Absorption		Gsb:		<table border="1" style="width: 100%;"> <thead> <tr> <th colspan="2">Gradation</th> </tr> </thead> <tbody> <tr><td style="text-align: center;">3/4"</td><td style="width: 50px;"></td></tr> <tr><td style="text-align: center;">1/2"</td><td></td></tr> <tr><td style="text-align: center;">3/8"</td><td></td></tr> <tr><td style="text-align: center;">No.4</td><td></td></tr> <tr><td style="text-align: center;">No.8</td><td></td></tr> <tr><td style="text-align: center;">No.16</td><td></td></tr> <tr><td style="text-align: center;">No.30</td><td></td></tr> <tr><td style="text-align: center;">No.50</td><td></td></tr> <tr><td style="text-align: center;">No.100</td><td></td></tr> <tr><td style="text-align: center;">No.200</td><td></td></tr> </tbody> </table>	Gradation		3/4"		1/2"		3/8"		No.4		No.8		No.16		No.30		No.50		No.100		No.200	
% AC:																																	
Viscosity:																																	
Gmm:																																	
% Absorption																																	
Gsb:																																	
Gradation																																	
3/4"																																	
1/2"																																	
3/8"																																	
No.4																																	
No.8																																	
No.16																																	
No.30																																	
No.50																																	
No.100																																	
No.200																																	

Comments: _____

Figure 7 RAP Stockpile Approval Letter