



## Florida Test Method for THERMAL COMPATIBILITY OF REPAIR MATERIALS WITH CONCRETE

Designation: FM 5-609

### 1. SCOPE

- 1.1 This method covers a thermal compatibility test to determine which mortars are subject to de-bonding when used as repair materials for concrete when the combination of the two is subjected to temperature changes that may be met in the field.
- 1.2 This method does not purport to address all of the safety concerns, if any, associated with its use. It is the responsibility of the user of the method to establish appropriate safety and health practices prior to use.

### 2. APPARATUS

- 2.1 Apparatus to Mix Portland Cement Concrete - This apparatus shall be as described in ASTM C 192.
- 2.2 Specimen Molds - The molds shall be 3 in. diameter 6 in. high, constructed in accordance with ASTM C 470.
- 2.3 Tamping Rod - The tamping rod shall be a round steel rod, 3/8 in. diameter and approximately 12 in. long, having both ends rounded to hemispherical tips. (Alternatively, an external vibrator may be used in accordance with ASTM C 192)
- 2.4 Apparatus for Mixing Repair Materials - The repair material shall be mixed in accordance with the manufacturers recommendations.
- 2.5 Testing Machine - The testing machine shall be as described in ASTM C 39.
- 2.6 Moist Room - The moist room shall conform to the requirements of ASTM C 511.
- 2.7 Environmental Chamber – The environmental chamber shall have the ability to maintain temperatures of  $40 \pm 3$  °F ( $4 \pm 2$  °C), and  $120 \pm 3$  °F ( $49 \pm 2$  °C), respectively, and  $50 \pm 5$  % RH.

### 3. MATERIALS

- 3.1 Cement - The cement shall meet the requirements of AASHTO M 85, Type I or II.
- 3.2 Coarse Aggregate - The coarse aggregate shall be a typical concrete aggregate, grade No. 89 meeting the requirements of the Florida Department of Transportation Standard Specifications for Road and Bridge Construction, Section 901.



- 3.3 Fine Aggregate - The fine aggregate shall be a typical natural silica sand meeting the requirements of the Florida Department of Transportation Standard Specification for Road and Bridge Construction, Section 902.
- 3.4 Portland Cement Concrete - The portland cement concrete shall be proportioned using ACI 211.1 to conform to the following requirements herein. The portland cement content shall be  $658 \pm 5$  lb/yd<sup>3</sup>. For the first trial mixture, refer to the table on volume of coarse aggregate per unit volume of concrete in ACI 211.1 for guidance on the amount of coarse aggregate to use, given the nominal maximum size of the aggregate and the fineness modulus of the fine aggregate being used. The water content shall be adjusted to obtain a slump of 3 in.  $\pm$  1 ½ in., with the minimum water content possible not exceeding a 0.41 water-cement ratio. The concrete shall be air-entrained within a range of 1% to 6%. After evaluation of the trial mixtures, aggregate proportions shall be adjusted as needed to obtain a properly proportioned workable concrete mixture. These conditions shall be achieved by making final adjustments in the proportion of fine aggregate to total aggregate or in the amount of total aggregate, or both, while maintaining the yield, slump and air content in the required ranges. The concrete shall have an average compressive strength within the range of 5500 to 6500 psi to constitute a valid test (*Note 1*). Make and cure the concrete in accordance with ASTM C 192.

**Note 1:** Concrete cylinders, when tested in accordance with ASTM C 39, will be needed to confirm this requirement. Chemical admixtures may be used to accelerate strength gain of the concrete.

#### 4. SAMPLE PREPARATION

##### 4.1 Concrete Test Specimens (Substrate):

- 4.1.1 The portland cement concrete test specimens (Fig. 1) shall be prepared in a 3 in. by 6 in. mold. The first portion of the composite test cylinders shall be formed by saw cutting a full size concrete cylinder on a 30-degree slope from vertical, giving a maximum height of 5.60 inches to a minimum height of 0.40 inches. The specimens shall be moist cured for at least seven (7) days prior to saw cutting. At the end of this period, the bonding surface shall be prepared by removing all loose particles and oily film. The specimen shall be surface dried only.
- 4.1.2 When the product's technical data sheet specifies that the product must be applied to dry substrate, omit the portion of section 4.1.1 requiring a surface dried specimen. After saw cutting the specimen and removing all loose particles and oily film, condition the specimen for seven (7) days at  $73 \pm 3$  °F ( $23 \pm 2$  °C), and  $50 \pm 5$  % RH.

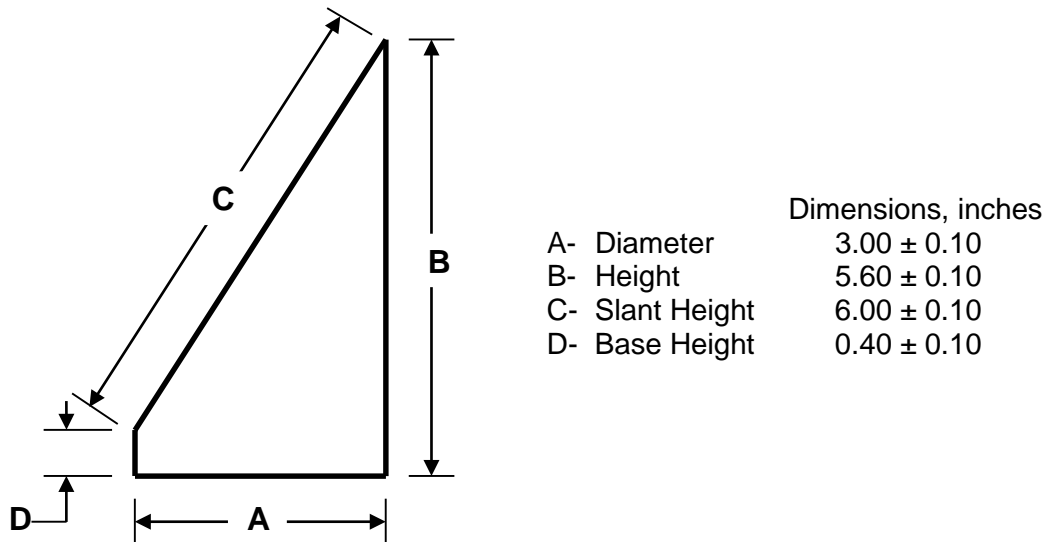

Fig. 1 – Concrete Test Specimens

#### 4.2 Composite Test Cylinders

- 4.2.1 Six (6) composite cylinders are required; three (3) for thermal cycling, and three (3) for control specimens.
- 4.2.2 The portion of the concrete cylinder shall be placed into the bottom of a cylinder mold. The patching material shall be *scrubbed* into the bonding surface of the concrete, filling all exposed pores and voids. After which, the remainder of the mold shall be immediately filled with the patching material, consolidated and finished (*Note 2*). Allow the specimens to moist cure until testing.
- 4.2.3 When the product's technical data sheet specifies that the product must be applied to dry substrate, cure the composite cylinders at  $73 \pm 3$  °F ( $23 \pm 2$  °C), and  $50 \pm 5$  % RH.
- 4.2.4 Grind or Cap the composite cylinders in accordance with ASTM C 39 or ASTM C 617, respectively.

**Note 2:** Mix the patching material in accordance with the manufacturers' recommendation.

#### 4.3 Thermal Cycling:

- 4.3.1 Cure composite cylinders for a minimum of 7 days before subjecting them to the thermal cycles.
- 4.3.2 The thermally-cycled composite cylinders shall be subjected to a minimum of 20 hours at 40 °F (4 °C), followed by a minimum of 20 hours at 120 °F (49 °C). This is one test cycle. Continue for four additional test cycles.

4.3.3 Once test cycles are completed, return cylinders to moist storage.

4.3.4 When the product's technical data sheet specifies that the product must be applied to dry substrate condition composite cylinders for a minimum of 24 hours at  $73 \pm 3$  °F ( $23 \pm 2$  °C), and  $50 \pm 5$  % RH before testing.

## 5. PROCEDURE

### 5.1 Thermally-Cycled Composite Cylinders:

5.1.1 Determine the maximum compressive force of three thermally-cycled composite cylinders, after grinding and capping, in accordance with ASTM C39.

### 5.2 Control Composite Cylinders:

5.2.1 Determine the maximum compressive force of three control composite cylinders, after grinding or capping, in accordance with ASTM C39.

## 6. CALCULATION

### 6.1 Bond Strength by Slant Shear of Thermally Cycled Composite Cylinder:

6.1.1 Calculate the average bond strength of the thermally cycled composite cylinders by dividing the maximum load at failure by the area of the bonded surface, 14.13 in<sup>2</sup> (*note 3*). Report the results to the nearest 10 psi.

### 6.2 Bond Strength by Slant Shear of Control Composite Cylinder:

6.2.1 Calculate the average bond strength of the control composite cylinders by dividing the maximum load at failure by the area of the bonded surface, 14.13 in<sup>2</sup> (*note 3*). Report the results to the nearest 10 psi.

**Note 3:** The area of the elliptical bonding surface of the concrete test specimen specified in this method, Fig. 1.

### 6.3 Ratio of Bond Strength by Slant Shear of Thermally-Cycled Composite Cylinders to Bond Strength by Slant Shear of Control Composite Cylinders

6.3.1 Determine the percentage of the bond strength of the control composite cylinders to the bond strength of the thermally-cycled composite cylinders. Report the result to the nearest whole percent.

## 7. REPORT

### 7.1 Report the following information:

- 7.1.1 Identification number
- 7.1.2 Manufacturer
- 7.1.3 Product name
- 7.1.4 Product type



- 7.1.5 Compressive strength of the concrete cylinders used to create substrate portion of composite cylinder
- 7.1.6 Bond strength of the thermally-cycled composite cylinders
- 7.1.7 Bond strength of the control composite cylinders
- 7.1.8 Percentage of the bond strength of the thermally-cycled composite cylinders to the bond strength of the control composite cylinders
- 7.1.9 Type and position of the fracture (in the repair material, in the concrete, or at the interface between them)
- 7.1.10 Defects in either the thermally-cycled composite cylinders or the control composite cylinders