

Chapter 4 – Table of Contents

Chapter 4 - Bridge Mechanics.....	4-1
4.1 Introduction	4-1
4.2 Basic Structural Mechanics.....	4-2
4.2.1 Axial Tension.....	4-2
4.2.2 Axial Compression	4-3
4.2.3 Shear	4-5
4.2.4 Flexure	4-6
4.2.5 Torsion	4-7
4.2.6 Stress.....	4-8
4.3 Bridge Deck	4-8
4.3.1 Load Path	4-9
4.3.2 Composite Sections	4-9
4.4 Superstructure	4-9
4.4.1 Description.....	4-9
4.4.2 Function	4-10
4.4.3 Load Path	4-12
4.5 Substructure.....	4-14
4.5.1 Description.....	4-14
4.5.2 Function	4-14
4.5.3 Load Path	4-14
4.6 Culverts	4-15
4.6.1 Description.....	4-15
4.6.2 Function	4-15
4.6.3 Load Path	4-16
4.7 Redundancy and Fracture Mechanics.....	4-16
4.7.1 Load Path Redundancy	4-16
4.7.2 Internal Redundancy	4-17
4.7.3 Structural Redundancy	4-17
4.7.2 Simple Span.....	4-18
4.7.3 Continuous Span	4-18
4.7.4 Cantilever Span	4-19

4.7.5 Fracture Mechanics	4-19
4.8 Waterway and River Mechanics	4-20
4.8.1 Purpose and Function of Channel Protection Features	4-20
4.8.2 Basic Hydraulics	4-20
4.8.3 Scour	4-21
4.8.3.1 General Scour	4-21
4.8.3.2 Contraction Scour	4-22
4.8.3.3 Local Scour	4-22
4.8.4 Channel and Embankment Erosion	4-23
4.9 Chapter 4 Reference List.....	4-23

Chapter 4 – List of Figures

Figure 4.1 Schematic of a Single-Span Bridge Supported by Piles.....	4-1
Figure 4.2 Axial Tension	4-2
Figure 4.3 Axial Tension in a Suspension Bridge.....	4-3
Figure 4.4 Axial Tension in a Cable-Stay Bridge.....	4-3
Figure 4.5 Axial Compression.....	4-4
Figure 4.6 Axial Compression in a Bridge.....	4-4
Figure 4.7 Example of Axial Compression in an Arch Bridge	4-5
Figure 4.8 Deformation Produced by Shear Forces	4-5
Figure 4.9 Shear Forces.....	4-6
Figure 4.10 Steel Bridge Girder. Diagonal Line Represents a Compression Path.....	4-6
Figure 4.11 Schematic of Flexure in a Member	4-7
Figure 4.12 Torsion Forces Tend to Twist or Rotate the Member along the Longitudinal Axis..	4-7
Figure 4.13 Curved Girder Bridge Showing Torsion Forces	4-8
Figure 4.14 Schematic of Applied Stress.....	4-8
Figure 4.15 Composite Section Comprised of a Concrete Deck on a Steel Girder	4-9
Figure 4.16 Stresses and Deflection.....	4-10
Figure 4.17 Computerized Representation of Stresses and Deflection.....	4-11
Figure 4.18 Secondary Structural Member Examples in a Superstructure	4-12
Figure 4.19 Pre-Fabricated Steel Truss on Barges	4-13
Figure 4.20 Bridge Cross-Section Illustrating.....	4-15
Figure 4.21 Non-Redundant Load Path Bridge (left) vs. Redundant Load Path Bridge (right)..	4-17
Figure 4.22 Internally Redundant Girder (left) vs. Internally Non-Redundant Girder (right) ...	4-17
Figure 4.23 Structurally Non-redundant Multiple Span Bridge	4-18
Figure 4.24 Structurally Non-Redundant Bridge vs. Structurally Redundant Bridge	4-18
Figure 4.25 Continuous Span Steel Bridge.....	4-19
Figure 4.26 Cantilever Span	4-19
Figure 4.27 Example of Severe Scour (Courtesy New Hampshire DOT).....	4-21
Figure 4.28 General Scour Schematic (top). Contraction Scour Schematic (bottom).....	4-22
Figure 4.29 Local Scour at a Pier. Plan View (top) and Elevation View (bottom).....	4-23

Chapter 4 - Bridge Mechanics

4.1 Introduction

The information presented in this chapter is an overview of bridge mechanics. For additional information, readers are encouraged to use the FHWA Bridge Inspector's Reference Manual (BIRM). The BIRM is referenced at the end of this chapter.

Bridge mechanics means the way in which forces act on a structure, and how the structure responds under those loads. The schematic in Figure 4.1 illustrates an archetypal bridge. The symbols used for the bearings indicate that it is a single-span, simply supported bridge, with one fixed-end (the triangle) and the other end free to roll or slide (the circle).

There are many types of structures, each of which can have a numbers of spans and configurations, but this simple figure will be suitable for illustrative purposes. The sketch illustrates the concept of *load path*, the direction that forces take when transmitting the weight of a truck to the ground beneath it. The weight of a single truck is applied to the top surface, the deck, and then passed on to superstructure elements that support the deck. The primary longitudinal structure members carry the loads to the ends of the bridge where it is carried through bearing to rest on the abutments. Abutments distribute the weight of the bridge and vehicles to the ground under the abutment footing. A spread footing spreads the load directly to the earth, but if a bridge is built on end-bearing piles, the footing transfers the loads deeper into the ground where it is supported by rock or other dense material.

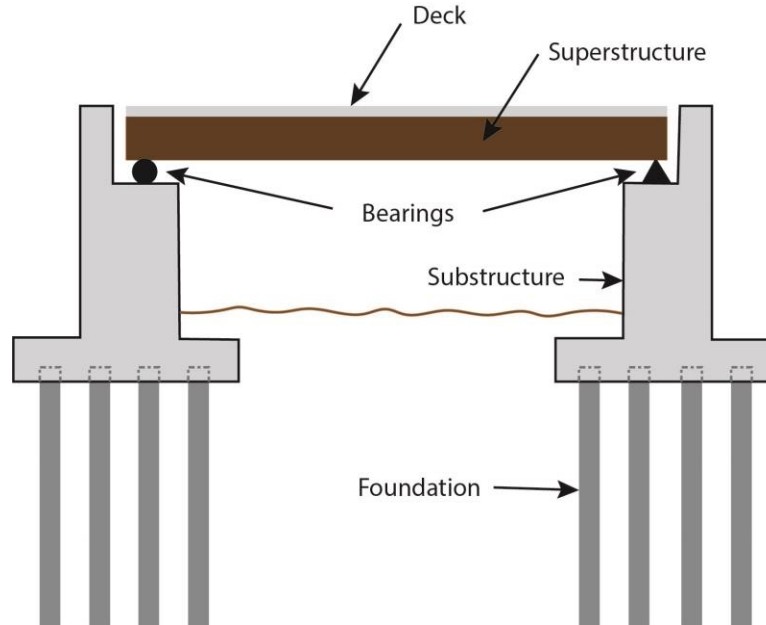

Figure 4.1 Schematic of a Single-Span Bridge Supported by Piles

The rest of this chapter uses specific types of bridges to illustrate certain broad concepts, but it should be recognized that there are many types of structures, and how a bridge carries loads depends on the specific structure.

Culverts are given a dedicated section below because, although they perform the same function as a bridge, culverts are structurally different from bridges. Culverts can be of various shapes and materials, but in most cases they rely on surrounding soil to assist in distributing loads from above to the ground underneath.

4.2 Basic Structural Mechanics

Bridges are subject to forces from many sources such as vehicular traffic, wind, seismic, ice flow, and temperature. Vehicular traffic is referred to as live load and is considered static. The bridge must be able to hold up its own weight, which is referred to as dead load. Dead loads also include permanent attachments such as signs and luminaires and utilities. Additional types of load include water, wind, and extreme-event (earthquake shift) loads and frictional forces. Each of these loads translates into a type of member force.

In bridge design, there are five member forces that are considered:

1. Axial tension
2. Axial compression
3. Shear
4. Flexure
5. Torsion

As a bridge maintenance worker, it is important to understand the types of forces and how forces affect a bridge member.

4.2.1 Axial Tension

Axial tension is a force that acts along the longitudinal axis of the member and tries to pull it apart. Figure 4.2 illustrates axial tension. The word “axial” is used because the force is straight down the middle of the member, so there is no bending or twisting.



Figure 4.2 Axial Tension

Imagine a bridge member in a tug of war; this is a simplistic but effective image. An example where axial tension is the only force is in bridge cables, such as a suspension bridge. Figure 4.3 illustrates axial tension in a suspension bridge. Tension forces are also present in the cables of a cable-stay bridge, as shown in the schematic Figure 4.4.



Figure 4.3 Axial Tension in a Suspension Bridge

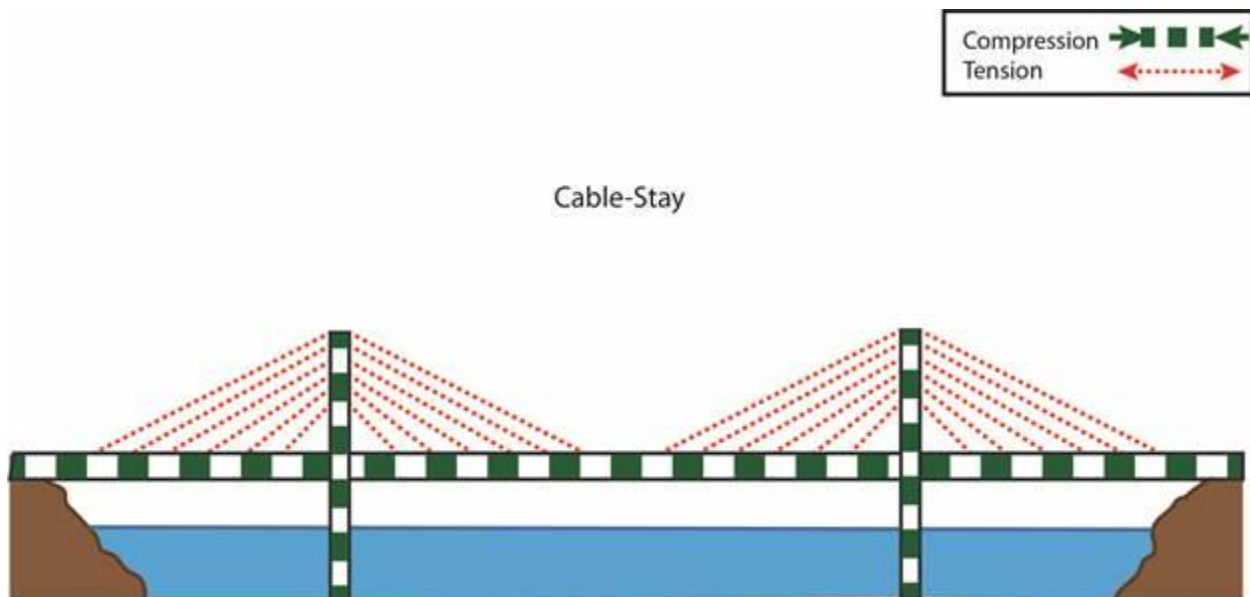

Figure 4.4 Axial Tension in a Cable-Stay Bridge

Most bridge members are subject to multiple forces, so axial tension is rarely the only force acting. Tension members are fabricated from materials that have high strength in tension (i.e., steel) which is not only strong in tension, but also compression and bending. This is why steel is used for compression and bending members, as well as tension members. Concrete is strong in compression, but weak in tension, so steel reinforcement (i.e., rebar) is embedded in the concrete to handle tension.

4.2.2 Axial Compression

Axial compression is a force that also acts along the longitudinal axis of a member, but pushes the member together. This is the exact opposite of axial tension. Figure 4.5 illustrates axial compression. Axial compression is a crushing force, such as an aluminum can being crushed. An

example of bridge members subject to axial compression are the concrete columns shown in Figure 4.6. Concrete is ten times as strong in compression compared to tension, so many bridge components in compression are made of concrete. The concrete column shown in Figure 4.6 has other forces acting on it besides axial compression. For example, the bridge deck expands and contracts during temperature fluctuations which may cause bending in the column. An example of axial compression in an arch bridge is shown in the schematic in Figure 4.7.



Figure 4.5 Axial Compression

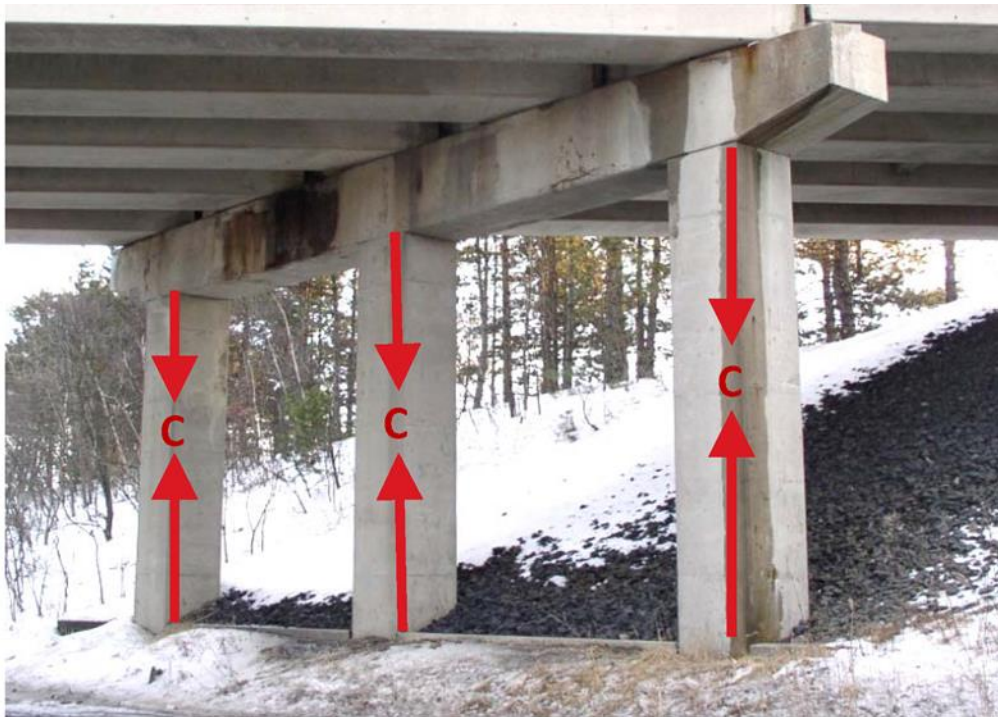

Figure 4.6 Axial Compression in a Bridge

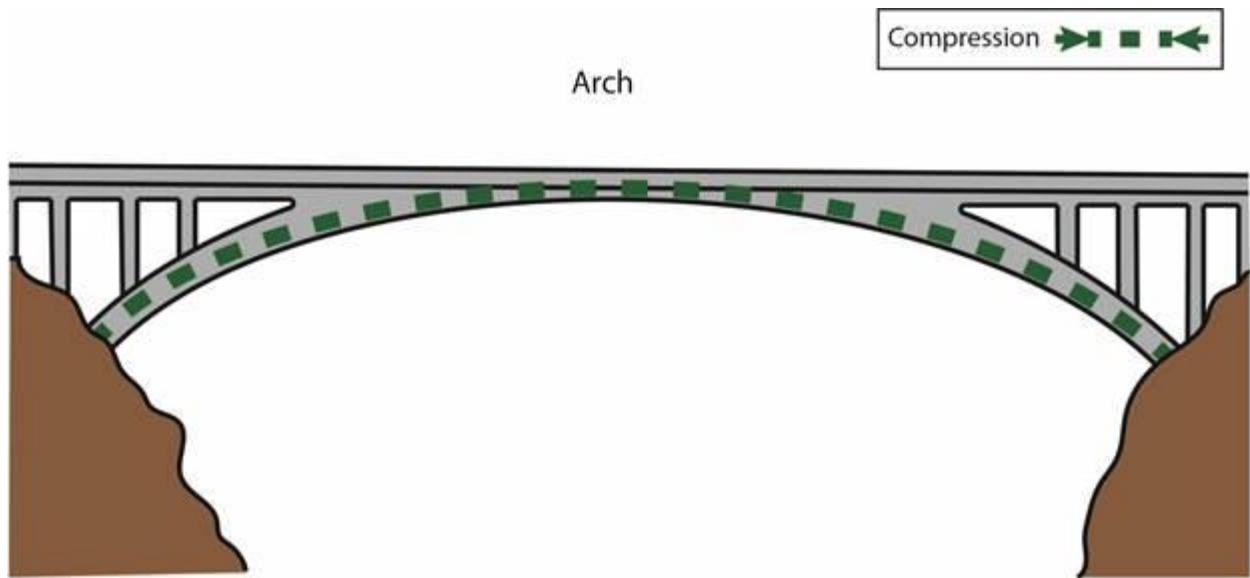

Figure 4.7 Example of Axial Compression in an Arch Bridge

4.2.3 Shear

Shear is a type of force which results from equal but opposite transverse forces that tend to slide one section of a member past another. Figure 4.8 (top) illustrates shearing force. Shear results in both diagonal tension and diagonal compression. Figure 4.8 (bottom) illustrates these forces and the resulting deformation. Where there is diagonal tension and the material is concrete, a crack may form in a direction perpendicular to the force. Similarly for diagonal compression, if the member is a steel plate (e.g., a girder web), the member could buckle and collapse.

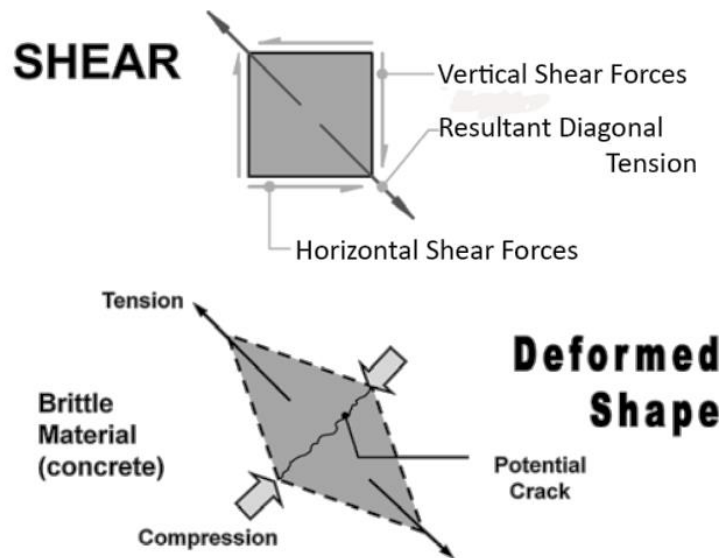

Figure 4.8 Deformation Produced by Shear Forces

A schematic of shear force is shown in Figure 4.9. An example of shear would be the deformation of a deck of playing cards as each card slides passed the one below it when pushed at the top.

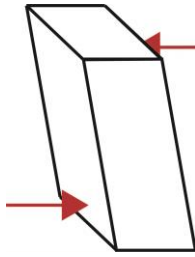

Figure 4.9 Shear Forces

Shear forces are greatest near supports such as a bridge bearing. Figure 4.10 shows a steel bridge girder with a diagonal line to represent a compression path. If the steel girder web is not thick enough, the web could buckle, which would be very serious. For this reason, many times vertical web stiffeners are present near supports to keep the web plate from buckling. Refer to Chapter 3 for more information on stiffeners.

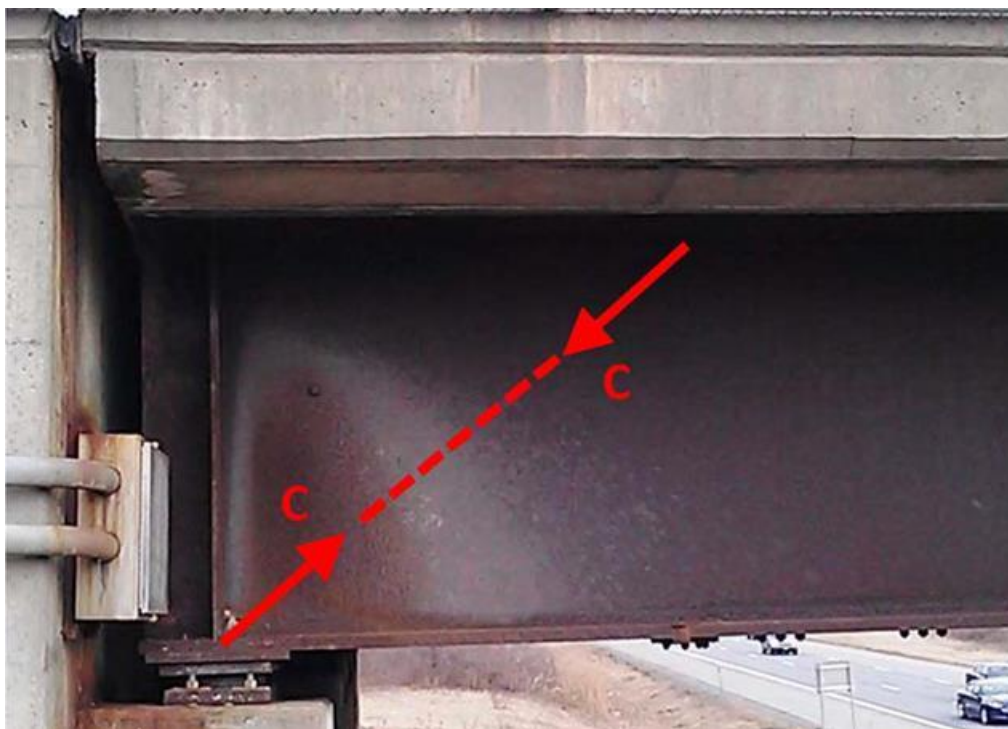

Figure 4.10 Steel Bridge Girder. Diagonal Line Represents a Compression Path.

4.2.4 Flexure

Flexure bends a member and produces a force called a moment, as depicted in Figure 4.11. An example of flexure is a diving board. As the board bends, the top surface is in tension while the bottom surface is in compression. A diving board is a cantilever.

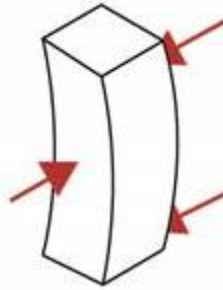

Figure 4.11 Schematic of Flexure in a Member

Moments can produce tension and compression in bridge members depending on the configuration. For example, Figure 4.4 is a suspension bridge. In the middle of the span, the bottom part of the girder is in tension; over the pier, it is in compression. Imagine the bridge wanting to sag in the middle of the span but is unable to do so over the pier because the girder is continuous. Designers determine where the steel girder is in tension and compression and determine flange sizes accordingly, which is why the steel flanges vary in width and thickness on many steel girder bridges. The designer could look at the worst case and make the flanges the same size throughout the bridge, but that would make the bridge very heavy and would be an inefficient design.

4.2.5 Torsion

Torsion is a type of shear force resulting from externally applied moments that tend to twist or rotate the member along its longitudinal axis. Figure 4.12 illustrates this twisting force. A good example is a curved girder bridge, such as shown in Figure 4.13. For a curved bridge, the load is eccentric to a straight line drawn between the two piers, producing a twisting action. For this reason, many curved steel girder bridges have heavy cross frames to counteract this twisting.



Figure 4.12 Torsion Forces Tend to Twist or Rotate the Member along the Longitudinal Axis

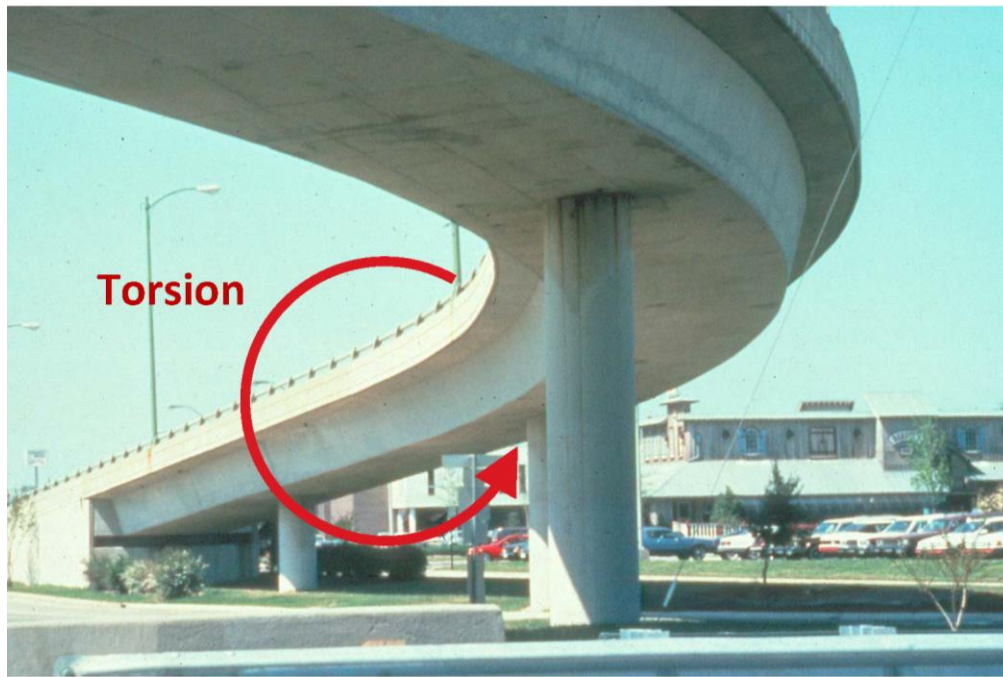

Figure 4.13 Curved Girder Bridge Showing Torsion Forces

4.2.6 Stress

A common term used in bridge design and construction is stress. Stress is defined as the amount of force applied over a given area, as shown in Figure 4.14.

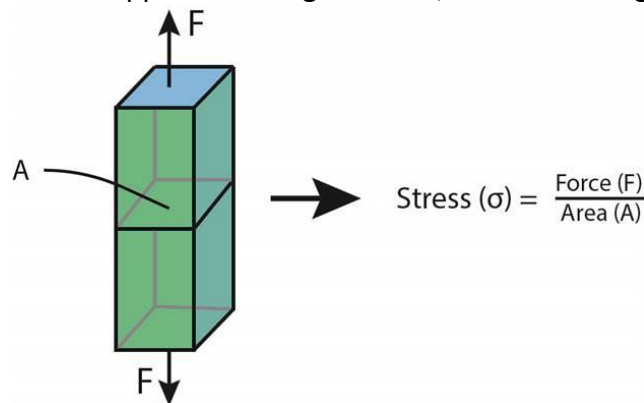

Figure 4.14 Schematic of Applied Stress

Concrete strength is defined as the compression stress at which the material fails. For concrete, this failure strength is about 4,000 pounds per square inch (psi). Steel is typically characterized by its failure stress in tension, or the tensile strength. The steel used in plate girders can have a tensile strength of 36,000 to 50,000 psi. Steel reinforcement typically has a tensile strength of around 60,000 psi. Note that compression strength and tensile strength are material properties, meaning that they don't vary with size of the structure or application.

4.3 Bridge Deck

This section deals with the mechanics of decks, such as load path and composite action.

4.3.1 Load Path

Vehicles apply a vertical load to the deck due to their weight. Gravity applies a pressure at the location of each tire, with the shape of the “footprint” being a rectangle since the rubber tire flattens out under the load. The pressure applied by the tires is transferred through the depth of the deck to the structural members that support the deck. In addition to the vertical loads, there are horizontal vehicle loads. Vehicles braking or accelerating introduce horizontal forces in the deck that must be transferred to the connections between the deck and its supports. Centrifugal forces generated when traffic passes over a curved bridge also produce horizontal loads.

4.3.2 Composite Sections

When concrete decks are used, it is common practice to fix them securely to the steel or concrete beams, so that the deck and beams act in unison. This is called a composite section. In the case of steel beams, shear studs are welded to the top flange before casting the concrete deck. After the deck cures, the concrete is effectively part of the beam. The resulting cross-section is stiffer than the steel beam alone, which reduces deflection due to live and impact loads. A sketch for a composite section is shown in Figure 4.15.

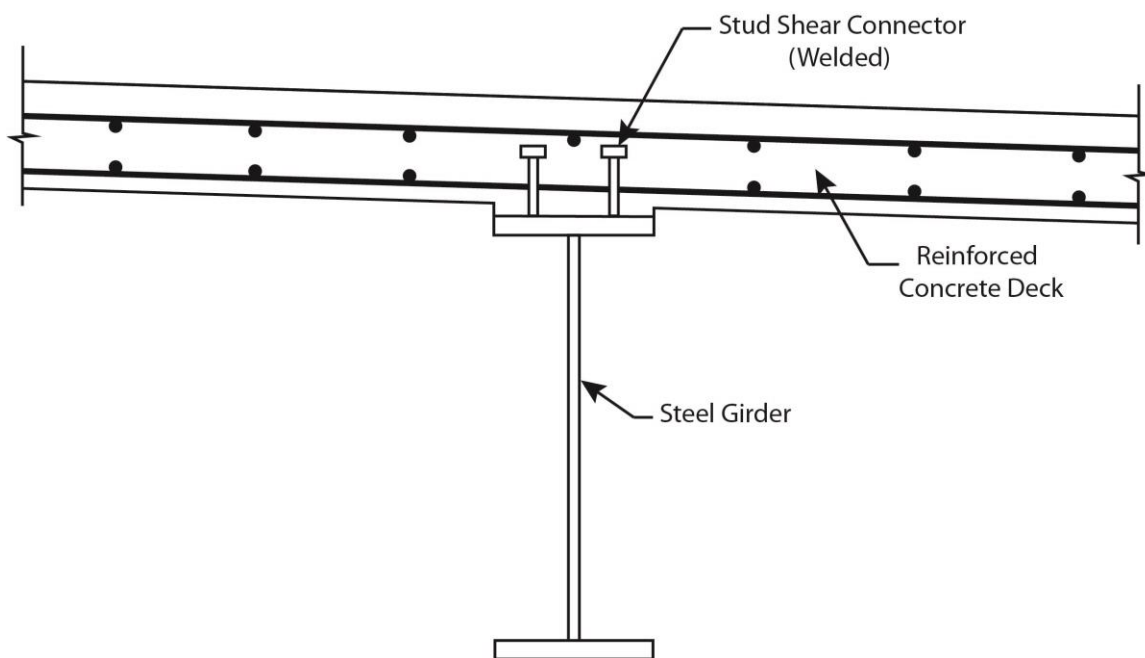

Figure 4.15 Composite Section Comprised of a Concrete Deck on a Steel Girder

4.4 Superstructure

4.4.1 Description

A bridge superstructure can consist of an arch, steel or concrete girders, steel rolled beams, timber beams, trusses, boxes, slabs, cable-supported structures or some other type of structure. The resultant superstructure provides the primary structural support across the stream or road that a bridge is crossing. It literally “bridges” the gap.

In addition to these primary structural members, many bridges also have secondary members as part of the superstructure. These do not provide the primary load path but contribute to the integrity of the bridge in other ways.

4.4.2 Function

A superstructure must meet both strength and serviceability criteria. It must be capable of carrying the loads imposed on it while remaining geometrically stable, and also not deflect excessively. Noticeable deflection could be disconcerting to motorists and could also cause degradation of the structure over time. Preventative maintenance is needed to keep the superstructure in good condition. Without preventive maintenance, deterioration may cause undue stress which may in turn compromise the ability of the superstructure to carry the loads for which it was designed.

Figure 4.16 is an image from a computer model that uses color to represent stress magnitude. This example was produced for a simulation of a deck carrying two heavy dump trucks. The highest stresses in the deck are shown at midspan in red, where the rear axles of two heavy dump trucks were simulated. Most of the girders at midspan are hidden by the deck in this figure, but it is noted that the stresses in the steel girders are maximum at midspan. As indicated by the color, the stresses in the ends of the steel girders are not as great as in the deck under the wheel loads. Deflection of the entire system can be observed.

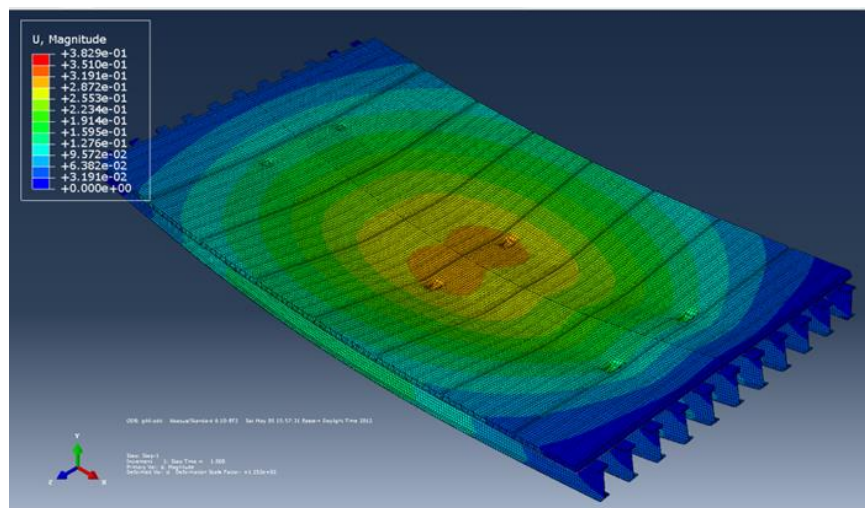

Figure 4.16 Stresses and Deflection in a Simply Supported Multi-Girder Bridge

Figure 4.17 is similar, but shows a one-lane slab bridge. Notice how the slab, which by definition has no girders, produces a different stress pattern. Also, the higher stress areas are at midspan, as will be the case for all simply supported one span bridges.

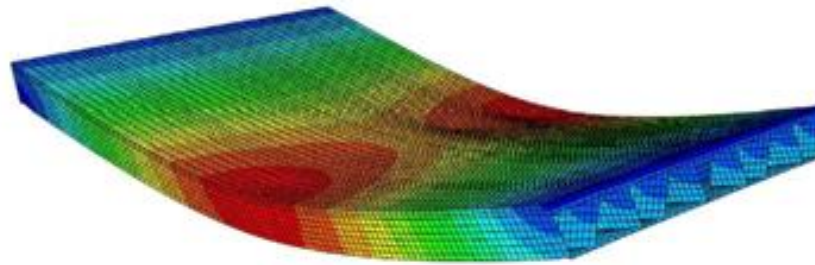

Figure 4.17 Computerized Representation of Stresses and Deflection in a Simply Supported Slab-Type Bridge

The superstructure must be designed to carry its own weight, the weight of the bridge deck, and any other dead, or permanent, load added. Additional permanent weights include the wearing surface, sidewalks, curbing, railings, utilities and lighting. The live, or transient, loads that the superstructure must support consist of vehicle and pedestrian traffic. Other vertical loads include snow and ice. There are also impact loads generated by traffic including braking, acceleration, and centrifugal forces. Other non-static loads are possible, such as loads from wind, stream currents, and earthquakes. Changes in the ambient air temperature, certain weld patterns, steel configurations and connections, corrosion and shrinkage (of wood and concrete) can also cause internal stresses. Design concepts that intentionally put internal stress into a girder include prestressing or post-tensioning of concrete girders. A bridge designer, inspector, or maintainer needs to account for the possibility of any of the above loads. Recent history teaches that there is potential for unexpected extreme events. Tidal surge, tsunamis, fire, or impact from trucks or marine vessels can damage a superstructure; the magnitude of the damage will depend on the location and the exposure of the superstructure to the additional stressors. Bridge loads are listed by type in Table 4.1.

Table 4.1 Typical Loads on Bridges

Dead Loads (Permanent Loads)	Live Loads (Transient Loads)	Dynamic Loads (Non-Static) Or Load Effects from Extreme Events	Internal Loads
<ul style="list-style-type: none"> • Self-weight of the structure • Wearing surface • Curbing • Sidewalks • Lighting • Utility lines 	<ul style="list-style-type: none"> • Weight of applied moving load of vehicles and pedestrians 	<ul style="list-style-type: none"> • Impact loading from a vehicle • Wind • Earthquakes • Drift against piers • Current • Ice • Impact from being hit by a vehicle or marine vessel 	<ul style="list-style-type: none"> • Thermal stresses from changes in ambient air temperature • Residual stresses from welding • Shrinkage • Pre-stressing • Post-tensioning

Each element in the superstructure must have the strength to resist the applied loads. Dead loads are predictable, live loads less so, and extreme loads, by their nature, are unpredictable. Both the frequency and the magnitude of extreme events can only be estimated.

The function of secondary structural members can be illustrated by considering a multi-girder bridge. These structures usually have cross bracing (or diaphragms) between the girders, as shown in Figure 4.18 left. These are important when the bridge is being built, because they provide stability during steel erection; diaphragms fulfill the same function later if the deck needs to be replaced. Since this cross bracing is in the vertical plane, it also serves the purpose of distributing dead and live loads among the girders. Lateral bracing, sometimes called wind bracing, is another type of secondary structural member (see Figure 4.18 right). This bracing type is placed horizontally between girders to stiffen the structure so it can resist wind loads.



Figure 4.18 Secondary Structural Member Examples in a Superstructure

4.4.3 Load Path

The superstructure (1) carries the weight of the bridge deck and the vehicles on it, and (2) transfers the vertical load to the bearings. The superstructure does this through its individual elements which may include stringers, floorbeams, cross bracings, and other members.

The loads from the deck and the traffic on it can be transferred to the superstructure regardless of the location of the deck in elevation. For instance, a long-span truss may be designed to carry the deck at the elevation of its lower chord, or the truss could be completely under the deck. Since traffic is constantly moving on a bridge, the load passing through the individual elements of a bridge changes as the loads shift. Imagine that there is only one heavy truck on a bridge; the bridge reaction to the weight of the truck changes as the truck moves across the bridge from one side to another. In fact, when the truck first moves onto the bridge, the majority of its weight is applied on just one or two bearings located directly underneath. In that case, the load path is a short one directly through the deck and primary member under it without much load distribution.

When performing maintenance work on elements that are part of the load path, it is imperative that a structural engineer be involved to ensure that all loads can be carried *during* the maintenance project as well as when the project is done. For instance, when removing significant amounts of deteriorated concrete from a column, a maintenance crew will need to have shoring in place to carry the weight of the bridge while repairs are being made. As soon as the weight is taken off a column by shoring under the end of a beam, the load path is changed. Instead of the wheel loads being transferred to deck, superstructure, bearings and substructure columns, the weight is taken up by the temporary shoring, by-passing the bearing and

substructure. This allows for the demolition and removal of concrete in the column so it can be replaced with sound concrete. Once the repair is made and concrete has cured, the shoring can be removed. This restores the original load path.

Figure 4.19 shows a prefabricated steel truss being barged into place prior to erection. Notice that the supports (shown in red) are not at the ends of the span where bridge bearings are usually found. By lifting the bridge at the red supports, the transport team is causing the self-weight of the structure to be transmitted through a different load path (i.e., the red supports) than when placed in service. Loads placed on a structure during construction are frequently different than when in service. Likewise, when a maintenance crew works on a bridge, it is important to remember that the load path in a superstructure might not stay constant. Loads are continually being shifted within the individual elements of the superstructure.



Figure 4.19 Pre-Fabricated Steel Truss on Barges

Any bridge can be mentally broken into its components and elements. For any of these elements, the strength (also referred to as capacity or resistance) of the member must exceed the loads that are going to be placed on the element. Since there is some variability and uncertainty in the strength of the members and the loads applied to them, safety factors are used to ensure that the values used in design are on the conservative side. For instance, if a particular stress cannot be accurately estimated, the assumed stress value will be multiplied by a factor to increase it. In this manner, the assumed stress value is assured to be higher than the stress that the bridge will actually carry. This provides a safety factor, in case the estimated value is low. Likewise, if the strength of a member is uncertain, then the designer will use a lower value so that the computations are conservative enough to cover the discrepancy. Designers call this probabilistic approach “Load and Resistance Factor Design” (LRFD).

Federal bridge inspection standards require that the live load carrying capacity be computed for newly constructed bridges and updated as needed for changes that might have occurred since previous inspections. The load rating can be affected by section loss due to corrosion, damage to a structural member, an increase in weight due to a wearing surface being added, as well as other factors. If the capacity decreases to the point that a bridge cannot carry the truck loads that are driving on it, with a reasonable safety factor, the bridge must be posted with a weight restriction. If this is the case, then it becomes important for operations staff to make sure the regulatory signs are in place and to monitor the types of vehicles using the bridge. If heavy trucks are using the bridge illegally, the police should be contacted to provide enforcement.

4.5 Substructure

4.5.1 Description

An example of a substructure is an abutment. Abutments are the supports at each end of a bridge that support the superstructure. Abutments transfer the loads applied through the bearings and spread them into the footing and foundation below. Piers (or bents) are substructure units used for intermediary support of multiple-span bridges. Either type of substructure unit can be made of steel, concrete, timber, masonry or geosynthetic-reinforced soil systems.

A bridge foundation is the part of the bridge support that is under the substructure. Steel, concrete or timber piles driven into the earth, concrete drilled shafts, or other underground supports, are the foundations for a bridge. Piles can be end-bearing (on rock or firm ground) or friction-bearing, in which case the piles are supported by soil pressures on the sides of the pile.

4.5.2 Function

The purpose of the substructure is to provide a secure support on which the superstructure can rest. Substructures hold back the embankment at the end of the bridge. Since the substructure is in direct contact with the earth, it is subjected to earth pressure, as well as frequent water and ice. The substructure units are required to provide strength, load distribution, and protect against settlement, tipping, overturning, and sliding at the base. Settlement or distortion of a substructure can induce unanticipated stresses in the superstructure. Scour, the loss of earth under the substructure in a river or marine environment, is a very important issue that is discussed in detail in Section 4.8.3. Erosion at the abutments can also jeopardize the integrity of the structure or render it unusable by cutting off access.

While the substructure needs to carry the loads imposed on it, it is just as important for it to maintain stability of the structure. For the substructure to function as intended, the substructure must bear securely on the soil or rock underneath it. Settlement, scour, erosion, and impact from a vessel or vehicle each have the potential to initiate instability and, if severe enough, they can cause collapse. Ground motion during an earthquake can also cause such instability.

4.5.3 Load Path

Since gravity pulls objects downward, the substructure must bear the weight of anything above it, as shown in the schematic in Figure 4.20. The schematic shows load being transferred from a truck through the deck into the girders, abutment and the ground. The substructure carries the weight of any vehicles that are on the bridge, the weight of the deck, the weight of the superstructure and bearings, as well as the effect of other loads.

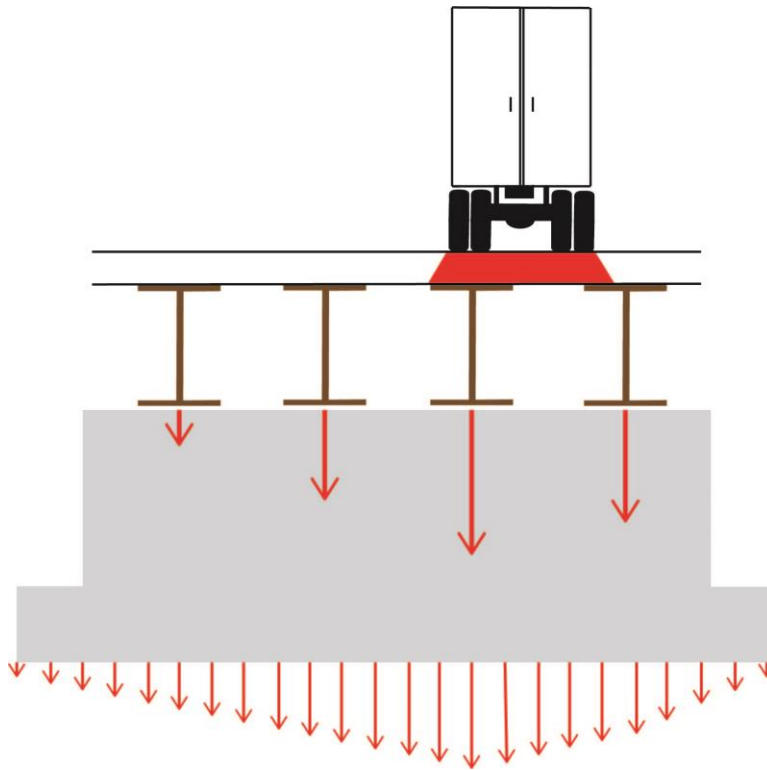

Figure 4.20 Bridge Cross-Section Illustrating Load Transfer

4.6 Culverts

4.6.1 Description

There are many types of structures that enable one to overcome an obstacle such as a stream, or road. According to the National Bridge Inventory (NBI), such a structure is classified as a bridge if it spans more than 20 feet. Although some smaller structures look just like a multi-girder bridge, they are considered culverts if less than 20 feet. The span is measured from one retaining wall to the other along the direction of traffic, directly under the center of the road. Examples of several types of culverts are provided in Section 3.1.5.

There are also many culverts over 20 feet. These are concrete box culverts, multi-plate pipe arches, or a series of smaller, closely-spaced pipes whose total span exceeds 20 feet. Approximately one of every five NBI structures in the country is a culvert (Barker and Puckett, 2007).

4.6.2 Function

Culverts are used to convey small streams under roadways, but also can be used for a street, pedestrian walkway, or even a cattle-pass under a highway embankment. Culverts can be cast-in-place or precast concrete, steel or aluminum pipe or plate arch, timber, or even FRP composite material. Culverts can have a bottom or not, depending on use and structure type. Culverts are included in this document because of their similarity to bridge structures. Much of the information presented is applicable to both.

4.6.3 Load Path

Although there are a variety of types of culverts, a general description of the load path may be helpful. The many varieties of culverts fall into two general categories: buried and unburied. A buried culvert has traffic load applied through an earth fill above it that is at least one foot thick. The required depth of earth fill varies according to the span. A good understanding of the soil-structure stress interaction is necessary since the surrounding soil transfers wheel loads to the structure. Traffic is maintained on a pavement, and the tires apply pressure to the pavement and subsequently the earth above the structure. Assuming the depth of earth cover is sufficient, this distributed earth pressure does a good job of transferring the dead and live loads to the top of the culvert. Depending on the type of structure, the loads can be transferred through the structure into the ground like an arch. Or, in the case of box with a horizontal roof, the roof carries loads to the vertical supports, using the roof as a means of transferring the loads, since it acts much like a slab bridge would.

If a culvert is not buried, traffic drives directly on it or on a wearing surface with no fill above the culvert. The mechanics of culvert load transfer are similar to that described in Section 4.4.3 Load Path, but dramatically different from a buried structure and so require different analysis methods.

4.7 Redundancy and Fracture Mechanics

Bridges that have more than one path for carrying loads are said to be redundant. Historically, limitations in computational capacity and the desire for efficient structures for economic reasons led to the construction of non-redundant bridge systems. Three types of redundancy are discussed in the following sections.

4.7.1 Load Path Redundancy

Structures can be protected from catastrophic failure by providing load path redundancy. Load path redundancy means having more than one load path. Truss bridges are considered non-redundant because there are only two trusses (as shown in Figures 3.53 and 3.54). If one fails, the entire span can collapse because there is no alternate load path. An example of this situation is the I-35W bridge that collapsed in Minneapolis in August 2007. Another example of a non-redundant bridge is the thru-girder bridge shown in Figure 3.51 and Figure 4.21 (left). A multi-girder bridge has numerous load paths, as shown in Figure 3.49 and Figure 4.21 (right). When many primary members are present, if one girder on a bridge fails, load can then redistribute among the other girders.

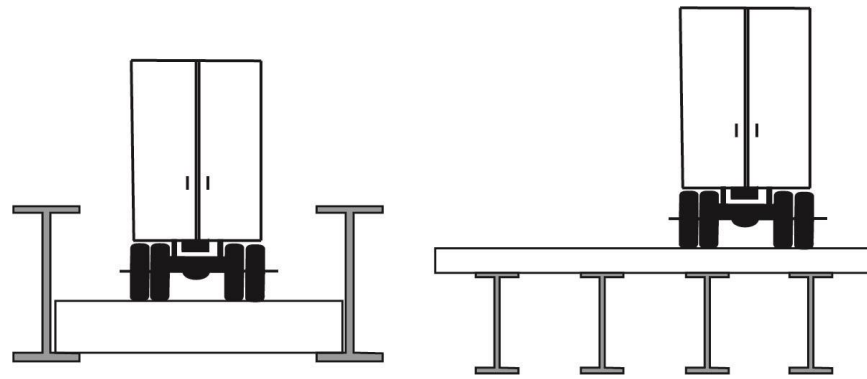

Figure 4.21 Non-Redundant Load Path Bridge (left) vs. Redundant Load Path Bridge (right)

4.7.2 Internal Redundancy

If a primary structural member is comprised of multiple elements, due to the method used for its fabrication, the member may have the ability to redistribute loads should one element crack or fail by some other means. An example is a built up riveted girder, because a defect in one of the internal elements cannot propagate to another and lead to the failure of the entire main member. Cracks can easily propagate through welds, so welded plate girders are not internally redundant. Examples of internally redundant and internally non-redundant girders are presented in Figure 4.22. In Figure 4.22 left, the riveted built-up girder is internally redundant, whereas the welded plate girder in Figure 4.22 right is internally non-redundant.

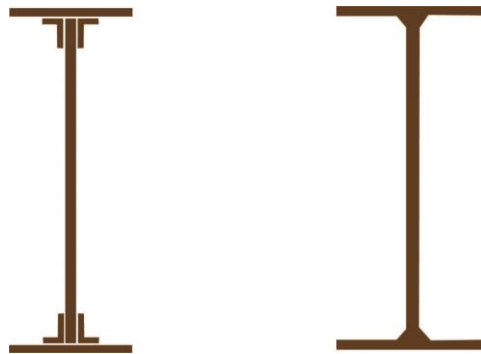

Figure 4.22 Internally Redundant Girder (left) vs. Internally Non-Redundant Girder (right)

4.7.3 Structural Redundancy

When a bridge consists of more than one span, a pier or bent is used as an intermediate support. In the past, it was common to construct these bridges as independent (i.e., simple) spans because analysis methods available at the time made it difficult to design other types of structures. A superstructure is said to have continuity if the primary structural members are continuous over the piers. Figure 4.23 shows a pier with a gap between the two girders and a bearing under each. This is an example of a bridge that is *not* structurally redundant. A structurally redundant bridge would have one beam continuous over the pier, or possibly two beams bolted together as part of a retrofit project to make them continuous.



Figure 4.23 Structurally Non-redundant Multiple Span Bridge

Continuity is desirable for several reasons. Continuity is more efficient structurally as it eliminates a joint over the pier that could leak and cause deterioration of the substructure. Continuity also helps to ensure stability of the structure if it is subjected to an earthquake, storm surge, or if the support of the pier is lost due to a truck impact or scour. Imagine a large truck hitting the pier and tilting it over a foot. The girder could easily fall off the pier ledge. Having the girders continuous over the pier would prevent this. Some older bridges can be made “continuous for live load,” by casting a concrete deck continuously over the gap between the ends of two adjacent spans to eliminate the pier joint.

Figure 4.24 shows a discontinuity at each pier in the left figure, indicating that the bridge is made up of multiple simple spans. The superstructure in the right figure is continuous over all piers, providing structural redundancy for the interior spans. The end spans are not redundant because there is no continuity at the end of the bridge. If one pier is lost due to scour or vehicular impact, the superstructure would not be in imminent danger of collapse.



Figure 4.24 Structurally Non-Redundant Bridge vs. Structurally Redundant Bridge

4.7.2 Simple Span

A simple span bridge is the easiest bridge type for an engineer to design, an example of which was shown in Figure 4.23. Many states liked the simplicity of the simple span bridge, in that if one component got damaged then it could easily be removed and replaced. However, simple span bridges have discontinuities in the superstructure at every support, and therefore have many joints. This is undesirable from a maintenance standpoint. Joints cause problems. Joints leak and allow salts and other contaminants to accumulate on the substructure below.

4.7.3 Continuous Span

Continuous span bridges are popular because deck joints can be reduced or eliminated, as shown in Figure 4.25. However, engineers must consider this continuity in their design. For example, a truck in one span can cause the adjacent span to deflect upwards due to the continuity of the girders.

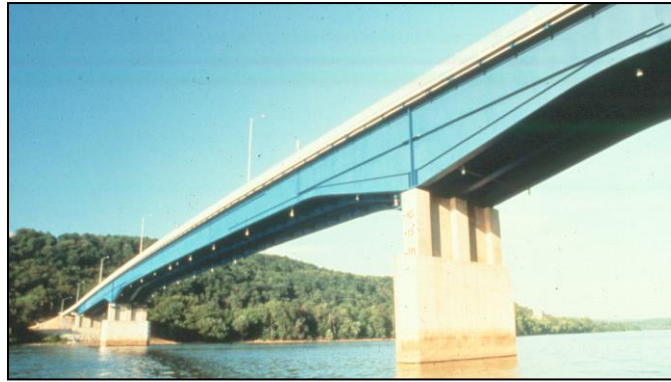

Figure 4.25 Continuous Span Steel Bridge

4.7.4 Cantilever Span

Cantilever span bridges not only have bearings located over the piers, but they some type of bearing assembly on the anchor spans supporting the cantilever spans, as shown in Figure 4.26. In some applications with steel girders, pins and hangers are used instead of bearings to connect the girders together.

The joints located with the span are the most critical expansion joints for bridge maintenance. The deterioration of girder ends and bearings that is common below expansion joints can cause a serious lack of support for the suspended span if the bearings or pin and hanger assemblies fail.

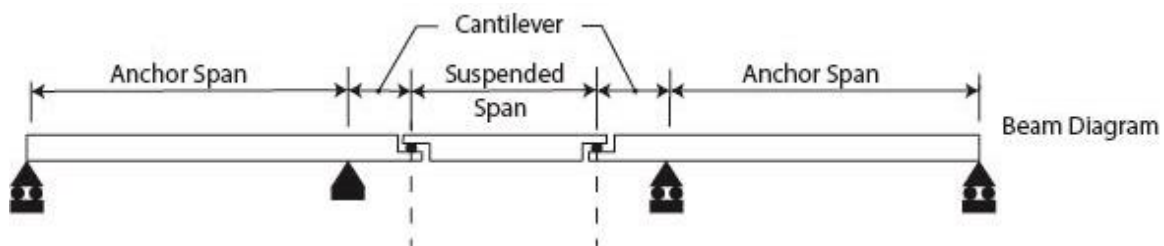

Figure 4.26 Cantilever Span

4.7.5 Fracture Mechanics

A maintenance worker should sound an alarm when a crack is found in a metal member. The rate that a crack propagates depends on numerous factors, but in certain instances a crack can occur suddenly and cause total collapse of a structure, especially if the structure is non-redundant. Stress levels, load cycles, temperature, and fabrication details all play a role in how fast a crack grows. The agency's bridge inspection office should be contacted whenever a crack is discovered in a primary steel bridge member.

Fracture toughness is a material property used to describe the ability of a metal to absorb energy without fracturing (or cracking). In steel, fracture toughness is commonly measured using a Charpy V-notch test. Certain materials, such as wrought iron, are especially susceptible to cracking. Because wrought iron exhibits low fracture toughness, even a small crack initiated by a material flaw can propagate and become a serious issue after a wrought iron element is placed in service. Even in modern steels, weld defects and certain weld details can initiate cracking. If a steel structural member is subjected to tensile and compressive stresses above a certain threshold range, fatigue cracks (i.e., cracks due to repeated cycling at stress significantly

less than the yield strength) will eventually develop due to stress cycling. Engineers have methods to estimate “remaining fatigue life” of a structure, but such methods rely on estimates of past truck traffic, particularly the truck weights and number of vehicles. Out-of-plane bending, typically where a diaphragm connects to a girder, can cause distortion-induced fatigue. Even small welds can cause major problems. A tack weld in a tension zone of a primary member can lead to cracking in primary members. For existing structures, anything that is attached to any part of the primary member with welds should be monitored for evidence of cracking. No welding should be undertaken without the involvement of a knowledgeable professional engineer.

It is important to be able to identify certain weld details that are known to be fatigue prone. AASHTO’s Manual for Bridge Evaluation contains detailed guidance. Examples of fatigue prone details are transverse cover plate end welds, the intersection of multiple welds, and spot welds.

4.8 Waterway and River Mechanics

Before any work is conducted in a waterway, it is important to apply for any required permits from regulatory agencies such as the Corps of Engineers and the state environmental agency. Often isolated site work near a bridge can have unanticipated negative impact elsewhere along the river.

4.8.1 Purpose and Function of Channel Protection Features

Moving water can do serious damage to bridge structures. In fact, about sixty percent of U.S. bridge failures are due to hydraulic forces

(<http://www.fhwa.dot.gov/advancedresearch/pubs/10034/10034.pdf>). In recent years, most DOT agencies have adopted a policy of installing piles or other scour protection measures under any substructure that is situated in water. Since flood waters are often turbulent and have high velocity, it is important that the river banks and substructures be able to withstand stresses imposed by such conditions. Vegetated banks are less susceptible to erosion. When properly designed, large stone (riprap) or paving blocks can be used to line channels and armor the bank close to the bridge. Inspection and maintenance of channel protection is important.

4.8.2 Basic Hydraulics

When a bridge is designed, it must be sized according to the volume of water that is expected to pass under it. This is done with rainfall intensity maps or equations for a given site, using a drainage area taken off of topographic maps. Computer programs originally developed by the U.S. Army Corps of Engineers (USACE) are used with survey data upstream and downstream from a bridge site, and the elevation of the design flood is determined. Usually, additional freeboard (the space between design high water and the bottom of the bridge) is provided so that trees, branches, and other debris carried by flood waters can pass under the bridge.

If flood waters get high enough to reach the bridge, the hydraulic pressure can cause the superstructure to move laterally or even uplift. This also affects how the water passes under the bridges. This pressure flow condition causes the water to speed up as it passes through the constricted opening, exacerbating scour at the site.

4.8.3 Scour

Scour is the term used to describe the loss of stream bed material due to hydraulic action. An example of severe scour is shown in Figure 4.27. A bridge is considered scour-critical if there is reasonable chance that scour can undermine the bridge, for instance if a pier in the water does not have any piles, the piles it has are known to be too short, or if the depth of the foundation is unknown. Scour is described in the following sections of this manual as one of three types (i.e., general, contraction, or local).



Figure 4.27 Example of Severe Scour (Courtesy New Hampshire DOT)

4.8.3.1 General Scour

General scour is a lowering of the streambed a distance up and downstream of the bridge. It is not caused by the bridge but by the natural tendency of the entire stream bed to decline in elevation due to soil particles moving downstream, especially during time of high water because fast moving water can easily pick up larger stones, as well as soil particles. During flood stage, a stream may be turbid because it is carrying much more sediment than during normal, non-flood conditions. General scour occurs because, over time, water picks up sand, stone and rocks and carries them downstream. Even a stream on bedrock can erode given enough time. Degradation can be exacerbated by gravel mining downstream of the bridge; a hole is created that the stream will naturally fill. Material is carried downstream and deposited in the created hole. The elevation of a streambed can also rise due to aggradation. The elevation and alignment of stream channels can change significantly over time, so bridge inspectors use drop-line readings from a bridge to measure the relative elevation of the bed and document the channel profile in the inspection reports. A schematic of general scour is shown in Figure 4.28 (top).

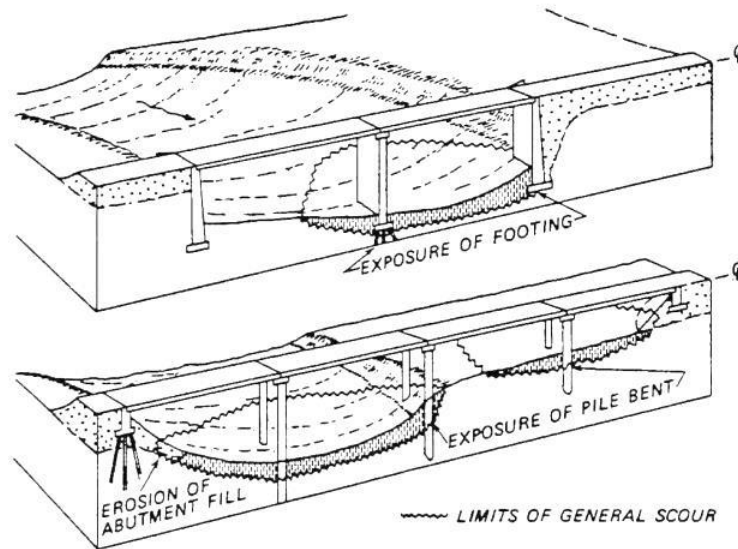

Figure 4.28 General Scour Schematic (top). Contraction Scour Schematic (bottom).

4.8.3.2 Contraction Scour

Contraction occurs when the opening under a bridge is too narrow for the flood waters running under it. One of the basic principles of hydraulics is that flowing water will speed up as it passes through a restricted area. Fast moving water picks up particles from the bottom of the stream, then causing scour. A schematic of contraction scour is shown in Figure 4.28 (bottom).

4.8.3.3 Local Scour

Local scour can occur at a pier that is located in the water. A good design will avoid piers in streams, but it is not always possible due to the expense associated with longer spans. If a pier on a new bridge must be a stream, it will be situated on piles that provide support in case scour does occur. If an existing bridge pier does not have piles under it, heavy stone can help protect it or sheet piling can be added.

Local scour can create very deep holes, over 20 feet in some cases. As flowing water hits the nose of a pier, it splits and flows around the pier stem and is forced in a downward direction (see Figure 4.29). The downward flow digs into the stream bed and makes the stone, gravel and sand waterborne, where it can be swept away in the current. Bridge skew, water velocity, size and shape of the stones in the riverbed all contribute to the severity of the resultant scour.

Some scour-critical bridges have been equipped with scour monitoring devices. Scour monitoring devices should be checked regularly to ensure proper operation.

The upstream nosing of piers in a river is usually rounded or V-shaped. The purpose of this geometry is to facilitate the flow of water around the pier. From a maintenance perspective, every effort should be made to keep this part of the pier clear of debris such as branches and logs. Debris and ice that catch on the nosing of a pier disrupt the smooth flow around the pier, causing turbulence and eddies. The disturbed flow results in roily water and scour.

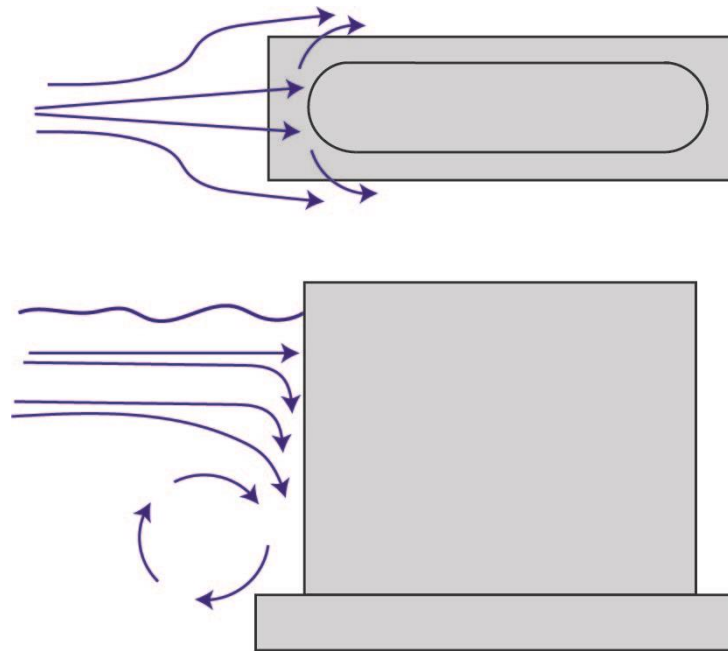

Figure 4.29 Local Scour at a Pier. Plan View (top) and Elevation View (bottom).

4.8.4 Channel and Embankment Erosion

Channel and embankment erosion are similar to scour, but occur to an embankment or soil that is normally dry. Heavy rains can initiate erosion of vegetation; without vegetation, the soil becomes exposed which then allows deterioration of the stream bank. Erosion can be a problem at the ends of bridges where the bridge has inadequate or poorly maintained drainage details.

4.9 Chapter 4 Reference List

1. AASHTO. *AASHTO LRFD Bridge Design Specifications, 5th Edition*. Washington D.C.: American Association of State Highway and Transportation Officials, 2010.
2. AASHTO. *Standard Specifications for Highway Bridges, 17th Edition*. Washington D.C.: American Association of State Highway and Transportation Officials, 2002.
3. AASHTO. *The Manual for Bridge Evaluation, 2nd Edition*. Washington D.C.: American Association of State Highway and Transportation Officials, 2008.
4. Barker, Richard M., and Jay A. Puckett. *Design of Highway Bridges, an LRFD Approach*. Hoboken, NJ: John Wiley and Sons, 2007.
5. FHWA. *Bridge Inspector's Reference Manual (BIRM)*. Report No. FHWA NHI 12-049, Washington D.C.: United States Department of Transportation, October 2002, Revised December 2006, Revised February 2012.
6. FHWA. *Steel Bridge Design Handbook: Loads and Load Combinations*. Report No. FHWA-IF-12-052, Vol. 7. Washington D.C.: U.S. Department of Transportation, 2012, <http://www.fhwa.dot.gov/bridge/steel/pubs/if12052/volume07.pdf>
7. FHWA. *Mapping the Future of Hydraulics Research: A Strategic Plan to Protect Highway Infrastructure*. Report No. FHWA-HRT-10-034, HRTM-04/01-10(1M)E, Washington D.C.: U.S. Department of Transportation, <http://www.fhwa.dot.gov/advancedresearch/pubs/10034/10034.pdf>