

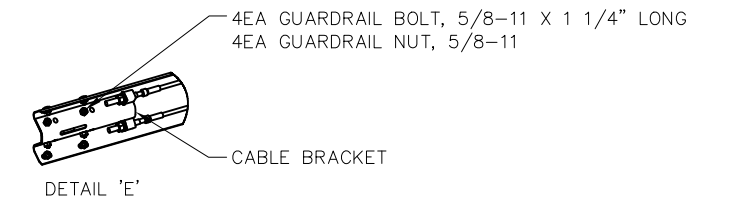

NOTES UNLESS OTHERWISE SPECIFIED:

1. THE X-TENSION CAN UTILIZE ANY OF THE FOLLOWING COMBINATIONS:
 - A. TIMBER POSTS WITH TIMBER BLOCKOUTS. (SHOWN)
 - B. STEEL W6X9 POSTS WITH TIMBER BLOCKOUTS.
 - C. STEEL W6X9 POSTS WITH PLASTIC BLOCKOUTS.
2. X-TENSION SYSTEM TO BE INSTALLED PER MANUFACTURER INSTRUCTIONS.
3. ONLY TIGHTEN THE CABLE ASSEMBLIES USING THE HEX NUTS AT CABLE BRACKETS AND ONLY AFTER THE FRICTION PLATE HAS BEEN TURNED AT THE HEAD WELDMENT. DO NOT TIGHTEN THE CABLE ASSEMBLIES AT THE FRONT OF THE GROUND ANCHOR.
4. THE SPECIAL SHEAR BOLTS USED TO CONNECT THE W-BEAM PANELS AT POST 5 ARE DIFFERENT THAN REGULAR SPLICE BOLTS. FOR EASY IDENTIFICATION, THEY ARE SUPPLIED WITH YELLOW HEADS.
5. ADDITIONAL HARDWARE IS PROVIDED TO SPLICE SYSTEM TO EXISTING GUARDRAIL AT POST 7

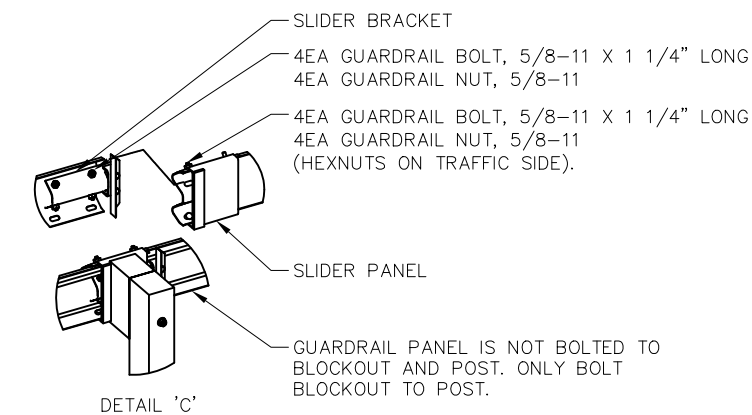
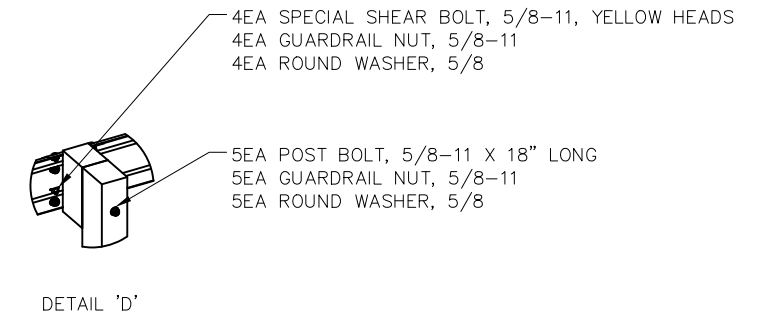
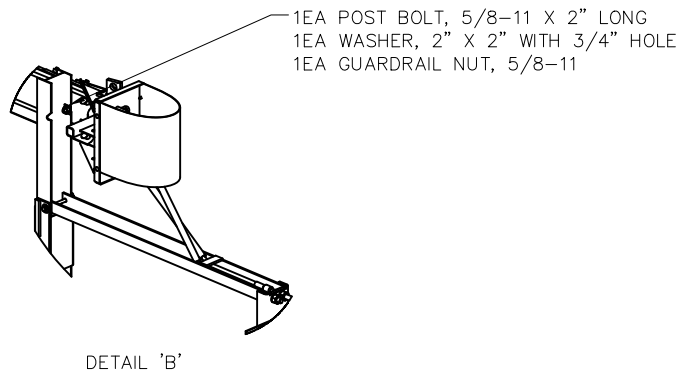
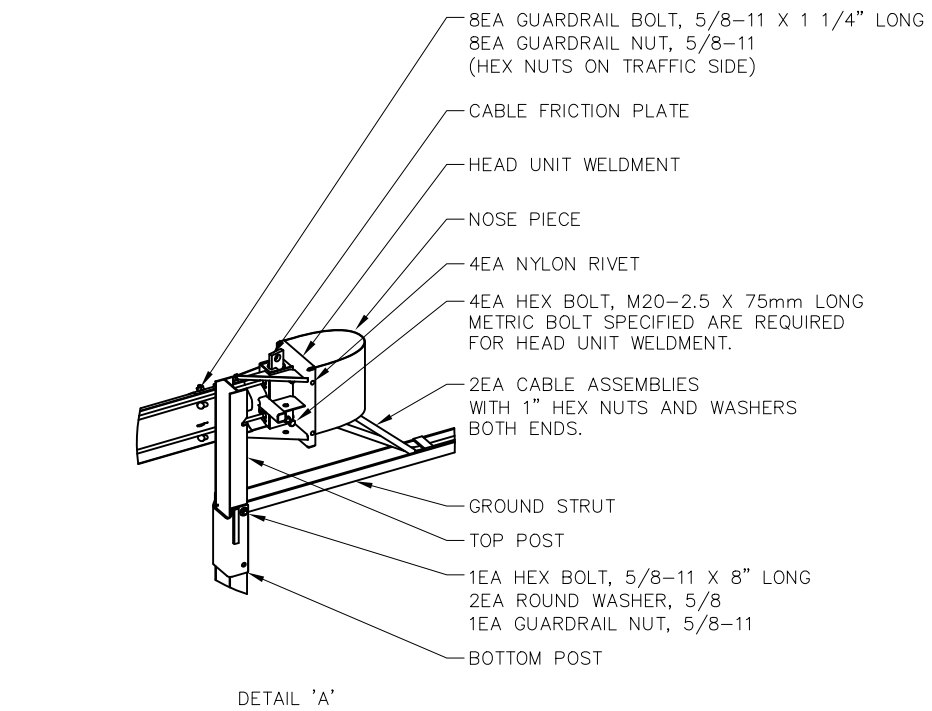
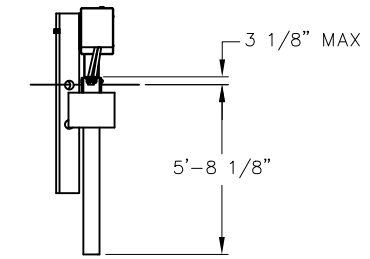

© 2009 Barrier Systems, Inc.							SCALE: NONE		Standard Tolerance	 BARRIER SYSTEMS <small>A LINDSAY TRANSPORTATION SOLUTIONS COMPANY</small>	
							DATE	INIT.	Angular ± 1/2"		
The information heron is proprietary to Barrier Systems inc. and shall not be disclosed, duplicated or used otherwise without the express written approval of Barrier Systems Inc.							DRAWN BY	JR	Fractional ± 1/16"		
							APPR'D BY	GAD	Decimal ± .010		
REV.	CHANGES	DATE	BY	REQ'D	NEXT ASS'Y	ITEM	TITLE: X-TENSION GUARDRAIL END TERMINAL, TANGENT		SHEET 1 OF 2	DRAWING NUMBER AP090903	REV. 0

TANGENT SYSTEMS

TIMBER POST WITH TIMBER BLOCKOUTS

PART #	QTY	PART DESCRIPTION	SPEC
B061072	1	HEAD UNIT WELDMENT	X-TENSION
B061058	1	CABLE FRICTION PLATE, HEAD UNIT	X-TENSION
B061079	1	SLIDER BRACKET WELDMENT	X-TENSION
B061088	1	SLIDER PANEL WELDMENT, W-BEAM	X-TENSION
B061083	1	CABLE BRACKET WELDMENT	X-TENSION
B061109	2	CABLE ASSEMBLY	X-TENSION
B061094	1	GROUND STRUT WELDMENT	X-TENSION
B061104	1	SOIL ANCHOR WELDMENT	X-TENSION
B061098	1	BOTTOM POST WELDMENT	X-TENSION
B061099	1	I-BEAM POST, TOP, POST # 1	X-TENSION
B071001	1	NOSE PIECE	X-TENSION
4002018	3	W-Beam Guardrail	FDOT
4002336	5	W-Beam Timber Blockout	FDOT
4002335	5	CRT Timber Post PDE09, POSTS # 2 - 6	FDOT
4002305	4	Nylon Rivet	X-TENSION
2001642	24	Guardrail Bolt 5/8-11 x 1 1/4"	FDOT
2000302	1	Post Bolt, 5/8-11 x 2"	FDOT
2001656	5	Post Bolt, 5/8-11 x 18"	FDOT
4001116	31	Guardrail Nut, 5/8-11	FDOT
2001717	1	Hex Bolt, 5/8-11 x 8"	FDOT
2001615	4	Hex Bolt, M20-2.5x75mm	FDOT
4002056	7	Round Washer, 5/8	FDOT
K080123	8	Special Shear Bolt w/ nut & washer	X-TENSION
B070805	1	Washer, 2" x 2" w/ 3/4" hole	FDOT

STEEL POST WITH TIMBER BLOCKOUTS

PART #	QTY	PART DESCRIPTION	SPEC
B061072	1	HEAD UNIT WELDMENT	X-TENSION
B061058	1	CABLE FRICTION PLATE, HEAD UNIT	X-TENSION
B061079	1	SLIDER BRACKET WELDMENT	X-TENSION
B061088	1	SLIDER PANEL WELDMENT, W-BEAM	X-TENSION
B061083	1	CABLE BRACKET WELDMENT	X-TENSION
B061109	2	CABLE ASSEMBLY	X-TENSION
B061094	1	GROUND STRUT WELDMENT	X-TENSION
B061104	1	SOIL ANCHOR WELDMENT	X-TENSION
B061098	1	BOTTOM POST WELDMENT	X-TENSION
B061099	1	I-BEAM POST, TOP, POST # 1	X-TENSION
B071001	1	NOSE PIECE	X-TENSION
B061100	1	I-BEAM POST, POST # 2	X-TENSION
4002018	3	W-Beam Guardrail	FDOT
4002337	5	W-Beam Timber Blockout	FDOT
4002338	4	Wide Flange Guardrail Post, POSTS # 3 - 6	FDOT
4002305	4	Nylon Rivet	X-TENSION
2001642	24	Guardrail Bolt, 5/8-11 x 1 1/4"	FDOT
2000302	1	Post Bolt, 5/8-11 x 2"	FDOT
2001635	5	Post Bolt, 5/8-11x10"	FDOT
4001116	31	Guardrail Nut, 5/8-11	FDOT
2001717	1	Hex Bolt, 5/8-11 x 8"	FDOT
2001615	4	Hex Bolt, M20-2.5x75mm	FDOT
4002056	2	Round Washer, 5/8	FDOT
K080123	8	Special Shear Bolt w/ nut & washer	X-TENSION
B070805	1	Washer, 2" x 2" w/ 3/4" hole	FDOT

STEEL POST WITH PLASTIC BLOCKOUTS

PART #	QTY	PART DESCRIPTION	SPEC
B061072	1	HEAD UNIT WELDMENT	X-TENSION
B061058	1	CABLE FRICTION PLATE, HEAD UNIT	X-TENSION
B061079	1	SLIDER BRACKET WELDMENT	X-TENSION
B061088	1	SLIDER PANEL WELDMENT, W-BEAM	X-TENSION
B061083	1	CABLE BRACKET WELDMENT	X-TENSION
B061109	2	CABLE ASSEMBLY	X-TENSION
B061094	1	GROUND STRUT WELDMENT	X-TENSION
B061104	1	SOIL ANCHOR WELDMENT	X-TENSION
B061098	1	BOTTOM POST WELDMENT	X-TENSION
B061099	1	I-BEAM POST, TOP, POST # 1	X-TENSION
B071001	1	NOSE PIECE	X-TENSION
B061100	1	I-BEAM POST, POST # 2	X-TENSION
4002018	3	W-Beam Guardrail	FDOT
4002339	5	W-Beam Plastic Blockout	FDOT
4002338	4	Wide Flange Guardrail Post, POSTS # 3 - 6	FDOT
4002305	4	Nylon Rivet	X-TENSION
2001642	24	Guardrail Bolt, 5/8-11 x 1 1/4"	FDOT
2000302	1	Post Bolt, 5/8-11 x 2"	FDOT
2001635	5	Post Bolt, 5/8-11x10"	FDOT
4001116	31	Guardrail Nut, 5/8-11	FDOT
2001717	1	Hex Bolt, 5/8-11 x 8"	FDOT
2001615	4	Hex Bolt, M20-2.5x75mm	FDOT
4002056	2	Round Washer, 5/8	FDOT
K080123	8	Special Shear Bolt w/ nut & washer	X-TENSION
B070805	1	Washer, 2" x 2" w/ 3/4" hole	FDOT

NOTES:

1. ALL GUARDRAIL POSTS, PANELS, BLOCKOUTS AND ASSOCIATED HARDWARE SHALL BE IN ACCORDANCE WITH FDOT STANDARD SPECIFICATION 536 & DESIGN STANDARD 400.
2. WHEN USING THE TIMBER BLOCKOUTS WITH TIMBER POSTS, THE BLOCKOUT SHALL BE TOE-NAILED IN ACCORDANCE WITH FDOT DESIGN INDEX 400, SHEET 15 OF 24.
3. FOR CONNECTIONS TO THRIE-BEAM GUARDRAIL, A "W-THRIE BEAM TRANSITION PANEL" CAN BE INSTALLED DOWNSTREAM OF POST # 7.

SHEET	DRAWING NUMBER	REV.
2 OF 2	AP090903	0