

*Assembly Instructions for*

# **MSKT MASH Tangent Terminal for 31" MGS (Midwest Guardrail System)**



***ROAD SYSTEMS, INC.***

P. O. Box 2163

Big Spring, Texas 79721

Phone: (432) 263-2435    FAX: (432) 267-4039

**Technical Support & Marketing Phone: (330) 346-0721**

**Technical Support & Marketing Fax: (330) 346-0722**

**[www.roadsystems.com](http://www.roadsystems.com)**

# Table of Contents

	<u>Page</u>
1. General Information .....	2-3
2. MSKT Design and Rail Options.....	4
3. Begin Assembly – Drawing & Photo Details .....	5
3.1 Bill of Materials for MSKT .....	5
3.2 Plan and Elevation View of MSKT System / <b>Figure 1</b> .....	6
3.3 Optional Flared Installation for MSKT / <b>Figure 2</b> .....	7
3.4 View of MSKT End Post #1 / <b>Figure 3</b> .....	8
3.5 Post #1 Connection Detail for MSKT / <b>Figure 4</b> .....	9
3.6 Post #2 Connection Detail for MSKT / <b>Figure 5</b> .....	10
3.7 Ground Strut Detail for MSKT / <b>Figure 6</b> .....	11
3.8 Installation of Cable Anchor (Box) Bracket & Shoulder Bolts / <b>Figure 7</b> ..	12
3.9 Impact Head Connection for MSKT / <b>Figure 8</b> .....	13
3.10 Grading Recommendations for MSKT / <b>Figure 9</b> .....	14
4. Installing the MSKT.....	15
4.1 Materials .....	15
4.2 Site Preparation .....	15
4.3 Tools Required .....	15
4.4 Installation Procedures.....	15
4.4.1 Installing Standard Steel Guardrail Posts #3 and Beyond .....	16
4.4.2 Installing Breakaway Steel End Posts #1 and #2 .....	16
4.4.3 Installing Ground Strut .....	17
4.4.4 Installing Guardrail .....	17
4.4.5 Installing Cable Anchor Bracket .....	18
4.4.6 Installing MSKT Impact Head .....	18
4.4.7 Installing Cable Assembly .....	19
5. Inspection Checklist for MSKT .....	20-21
6. Repairing the MSKT.....	22
7. Allowable Options for the MSKT.....	23

# 1 General Information

---

This Installation Manual is for the MSKT-SP-MGS (Standard Post / Steel Post) terminal called the **MSKT**. The MSKT is intended for use with the MASH MGS (Midwest Guardrail System) 31" tall W-Beam barrier. The MSKT is a steel post terminal that can be attached to steel post or wood post MGS barrier.

The MSKT was designed and crash tested as a redirective gating terminal to meet the requirements of the American Association of State and Highway Transportation Officials (AASHTO) Manual for Assessing Safety Hardware (MASH) criteria Test Level 3 (100 km/hr). The MSKT is eligible for Federal-aid reimbursement for use on the National Highway System. It is the responsibility of the installer to utilize a design approved by the State DOT and to follow all required State procedures and these instructions in installing the MSKT terminal.

## **This Installation Manual is divided into 7 sections**

- General Information for MSKT Steel Post Design.
- MSKT Design & Rail Length Options – This area describes the different rail options to choose from for creating the mid-span splice on the MSKT. (page 4)
- MSKT Drawing & Photo Details – This area shows a bill of materials and assembly details for the MSKT. (pages 5 - 14)
- Installing the MSKT – This section gives a step-by-step procedure on the proper assembly of MSKT Standard Post system. (pages 15 - 19)
- Inspection Checklist for MSKT – Use the checklist to inspect new installations or recently maintained/repaired installations. (page 20)
- Repairing the MSKT – This section gives general repair procedures for the MSKT Standard Post system. (page 21)
- Allowable Options for the MSKT – This section lists the various FHWA letters showing different configurations/options for the MSKT. (page 22)

## **The Following Pay Limit Lengths are accepted for use with the MSKT**

Measurement and payment shall be for each MSKT Standard Post Guardrail End Treatment measured complete and in place as shown in the installation instructions and on the contract plans. The pay limit options may be as shown below. *NOTE: MGS barrier requires mid-span splices between posts. Pay limits often vary by 3'- 1½" (depending on rail lengths) from those shown below.*

- 12.5 ft – **Hinged Posts #1 & #2**. Posts #3 - #8 shall be W6x9# x 6'-0" standard guardrail posts (for a TL-3 system). This has a 12.5 ft pay limit.
- 25 ft – **Hinged Posts #1 & #2**. Posts #3 - #8 shall be W6x9# x 6'-0" standard guardrail posts (for a TL-3 system). If this is a TL-2 (70 km/h - 43 mph), requires 5 total posts.
- 37.5 ft – **Hinged Posts #1 & #2**. Posts #3 - #8 shall be W6x9# x 6'-0" standard guardrail posts (for a TL-3 system).
- 50 ft – **Hinged Posts #1 & #2**. Posts #3 - #8 shall be W6x9# x 6'-0" standard guardrail posts. This is a TL-3 system and has a 50 ft pay limit.

## General Information (continued)

The MSKT is a tangent redirective and gating single-sided W-Beam terminal with a length-of-need (LON) point at post #3. The MSKT uses 8" or 12" offset blocks and is designed to be attached to strong post W-Beam guardrail systems (using 8" or 12" offset blocks) that have been tested and accepted under the MASH crash testing criteria. If the MSKT is intended to attach to a rigid barrier, a transition to gradually increase the stiffness in the W-Beam shall be required. The terminal would have a length of 50'-0" for TL-3. Check the State standard sheets or contract plans to see which option is approved in your State.

The MSKT is a tangent terminal and no offset is required. However to avoid nuisance impacts, a straight flare offset of 1-ft but no more than 2-ft (25:1 maximum) is recommended over a 50 ft length. For TL-2 applications, the flare rate is the same and the allowable offset is variable anywhere between zero and 1-ft over a 25 ft length. Design, selection & placement of the MSKT system shall conform to the *AASHTO Roadside Design Guide* and the details shown on the contract plans. The assembly of the MSKT shall be in accordance with the recommendations of Road Systems, Inc.

**NOTE:** Anywhere a W6x9# x 6'-0" standard guardrail post is mentioned throughout this manual, a W6x8.5# x 6'-0" standard guardrail post is equivalent and is permitted.

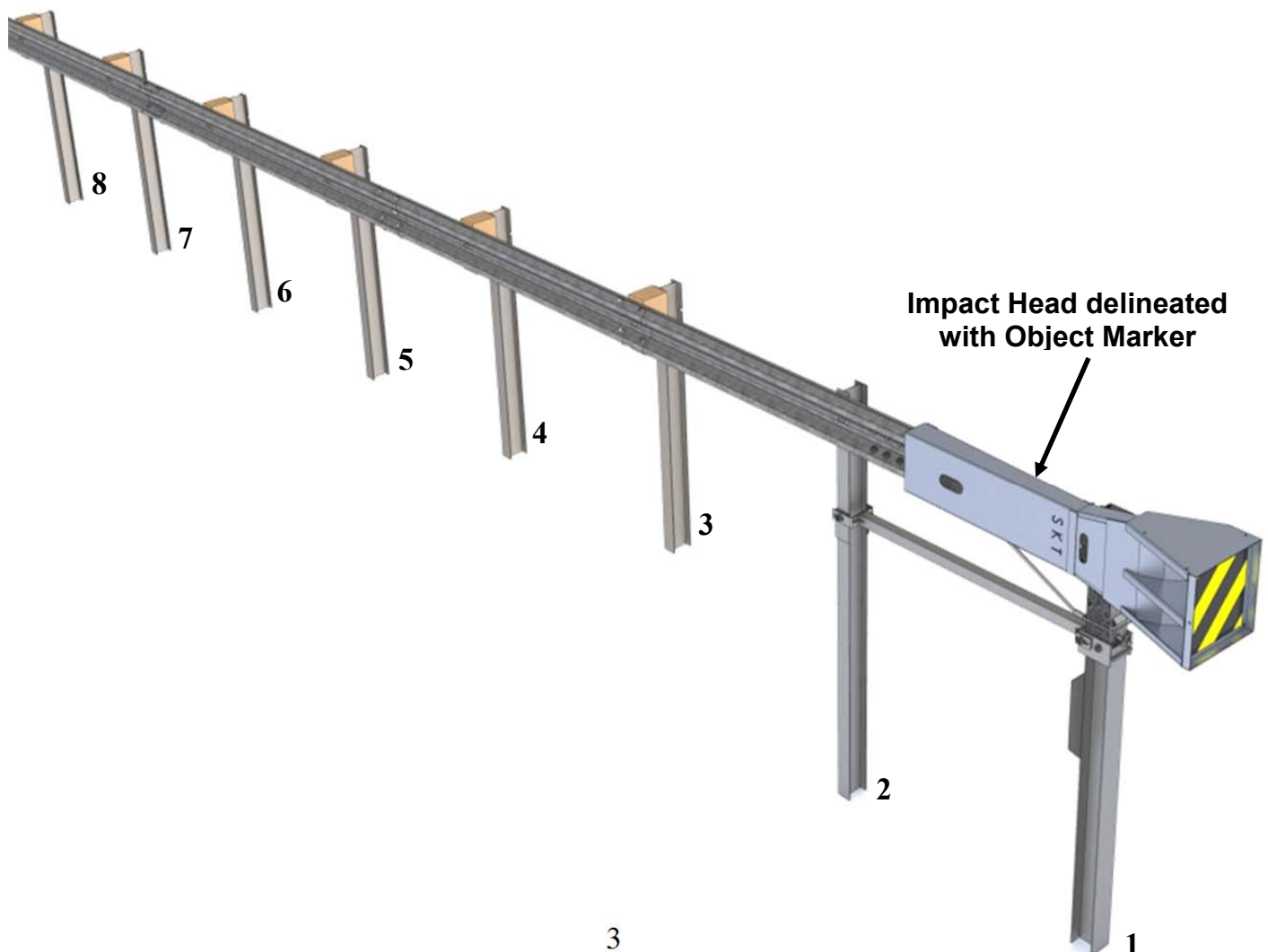

## 2 MSKT Design and Rail Options

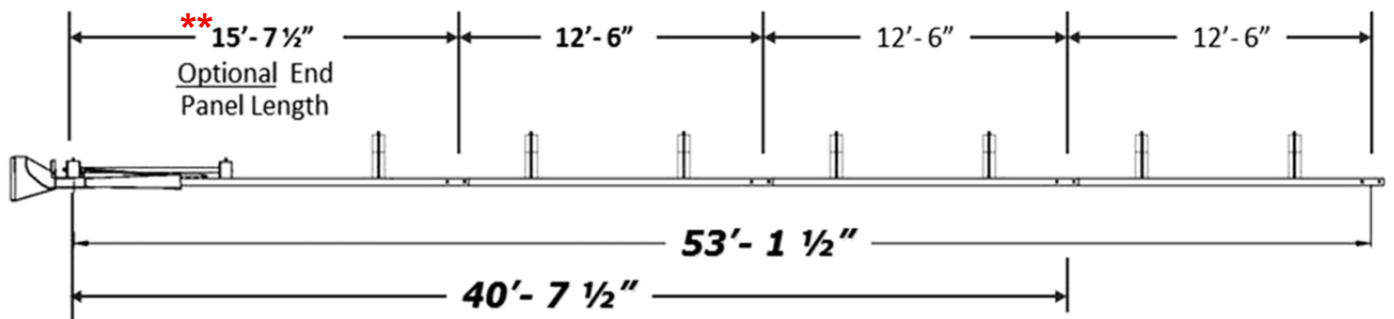
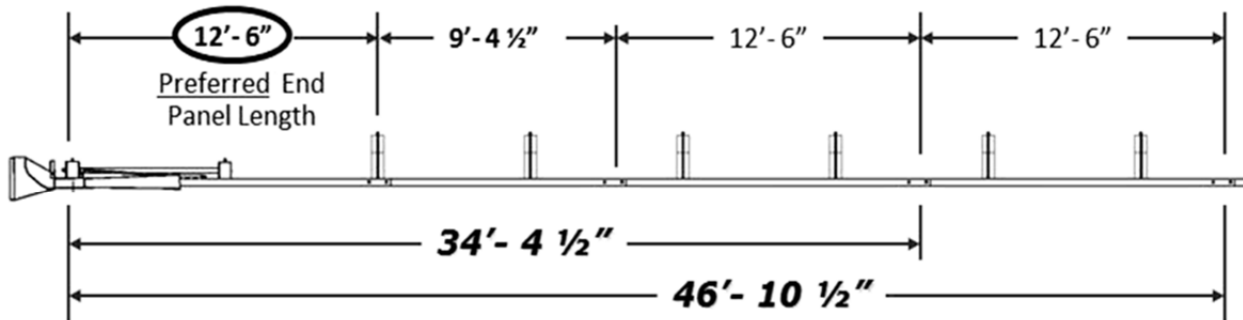
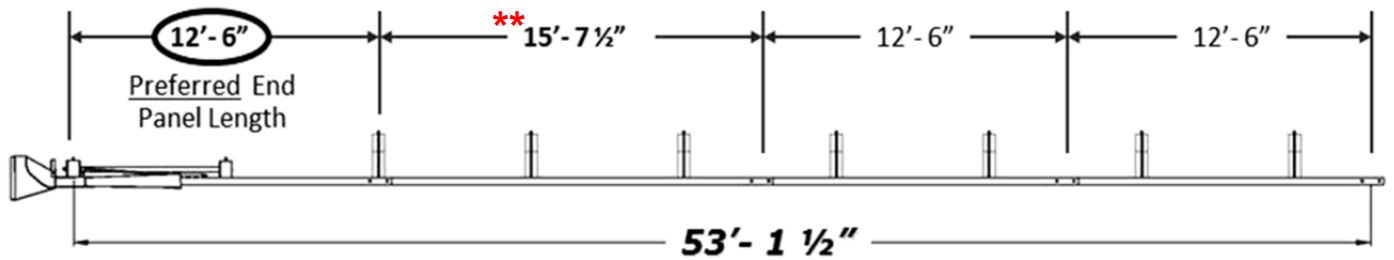

- NOTES:**
- 1.) The above rail length options are allowable for the MSKT.
  - 2.) Blockouts are 8" or 12" deep to match the W-Beam barrier that the specifying agency has shown downstream of the MSKT.

**\*\* FHWA Open Letter to all in the highway safety hardware and roadside design community dated May 26, 2017 states "FHWA will no longer provide Federal-aid eligibility letters for modifications made to an AASHTO MASH-crash tested device."**

It further states "The changes promote efficiency of Federal resources while advancing our Federal role to support public safety and ensuring that decision-making is at the State and local level. The FHWA will address the initial "entry" of a device into the possibility for Federal-aid reimbursement, through examining crash testing, but the final decisions on selection and modifications to devices will be at the State and local level.

It also says "States and manufacturers will now have an outstanding opportunity to collaborate and deploy manufacturers' innovative modifications in a timely manner and/or respond to State-specific needs requiring significant and non-significant modifications - without the need of another Federal-aid eligibility letter from FHWA."

# 3 Begin Assembly – Drawing & Photo Details

## 3.1 Bill of Materials for MSKT with 8" and 12" blockouts

ITEM	QTY	BILL OF MATERIALS	ITEM NO.
A	1	IMPACT HEAD	MS3000
B	1	W-BEAM GUARDRAIL END SECTION, 12 Ga.	SF1303
C	1	FIRST POST TOP (6X6X $\frac{1}{8}$ " Tube)	MTPHP1A
D	1	FIRST POST BOTTOM (6' W6X15)	MTPHP1B
E	1	SECOND POST ASSEMBLY TOP	UHP2A
F	1	SECOND POST ASSEMBLY BOTTOM	HP2B
G	1	BEARING PLATE	E750
H	1	CABLE ANCHOR BOX	S760
J	1	BCT CABLE ANCHOR ASSEMBLY	E770
K	1	STRUT	MS785
L	6	6x9 (6x8.5) STEEL POST	P621
M	6	RECYCLED PLASTIC BLOCK OR EQUIV.	CBSP-14
N	1	W-BEAM MGS RAIL SECTION (9'-4 1/2")	G12025
O	2	W-BEAM MGS RAIL SECTION (12'-6")	G1203A
HARDWARE (ALL DIMENSIONS IN INCHES)			
a	2	5/16 x 1 HEX BOLT GRD 5	B5160104A
b	4	5/16 WASHER	W0516
c	2	5/16 HEX NUT	N0516
d	25	5/8 Dia. x 1 1/4 SPLICE BOLT (POST #2)	B580122
e	2	5/8 Dia. x 9 HEX BOLT A449	B580904A
f	3	5/8 WASHER	W050
g	33	5/8 Dia. H.G.R NUT	N050
h	1	3/4 Dia. x 8 1/2 HEX BOLT GRD A449	B340854A
j	1	3/4 Dia. HEX NUT	N030
k	2	1 ANCHOR CABLE HEX NUT	N100
l	2	1 ANCHOR CABLE WASHER	W100
m	8	1/2 RSI SHOULDER BOLT W/WASHER	SB12A
n	8	1/2 STRUCTURAL NUT	N012A
o	8	1/2 STRUCTURAL WASHER	W012A
p	1	BEARING PLATE RETAINER TIE	CT-100ST
q	6	5/8" x 10" H.G.R. BOLT	B581002

Bill of Materials for MSKT with 8" blockouts

ITEM	QTY	BILL OF MATERIALS	ITEM NO.
A	1	IMPACT HEAD	MS3000
B	1	W-BEAM GUARDRAIL END SECTION, 12 Ga.	SF1303
C	1	FIRST POST TOP (6X6X $\frac{1}{8}$ " Tube)	MTPHP1A
D	1	FIRST POST BOTTOM (6' W6X15)	MTPHP1B
E	1	SECOND POST ASSEMBLY TOP	UHP2A
F	1	SECOND POST ASSEMBLY BOTTOM	HP2B
G	1	BEARING PLATE	E750
H	1	CABLE ANCHOR BOX	S760
J	1	BCT CABLE ANCHOR ASSEMBLY	E770
K	1	STRUT	MS785
L	6	6x9 (6x8.5) STEEL POST	P621
M	6	RECYCLED PLASTIC BLOCK OR EQUIV.	P618
N	1	W-BEAM MGS RAIL SECTION (9'-4 1/2")	G12025
O	2	W-BEAM MGS RAIL SECTION (12'-6")	G1203A
HARDWARE (ALL DIMENSIONS IN INCHES)			
a	2	5/16 x 1 HEX BOLT GRD 5	B5160104A
b	4	5/16 WASHER	W0516
c	2	5/16 HEX NUT	N0516
d	25	5/8 Dia. x 1 1/4 SPLICE BOLT (POST #2)	B580122
e	2	5/8 Dia. x 9 HEX BOLT A449	B580904A
f	3	5/8 WASHER	W050
g	33	5/8 Dia. H.G.R NUT	N050
h	1	3/4 Dia. x 8 1/2 HEX BOLT GRD A449	B340854A
j	1	3/4 Dia. HEX NUT	N030
k	2	1 ANCHOR CABLE HEX NUT	N100
l	2	1 ANCHOR CABLE WASHER	W100
m	8	1/2 RSI SHOULDER BOLT W/WASHER	SB12A
n	8	1/2 STRUCTURAL NUT	N012A
o	8	1/2 STRUCTURAL WASHER	W012A
p	1	BEARING PLATE RETAINER TIE	CT-100ST
q	6	5/8" x 14" H.G.R. BOLT	B581402

Bill of Materials for MSKT with 12" blockouts

**Post #3 and beyond are W6 x 9# or W6 x 8.5# x 6'-0" long standard steel guardrail posts. Blockouts are 8" or 12" deep to match the MGS W-Beam barrier that the specifying agency has shown downstream of the MSKT.**

### 3.2 Plan and Elevation view of MSKT

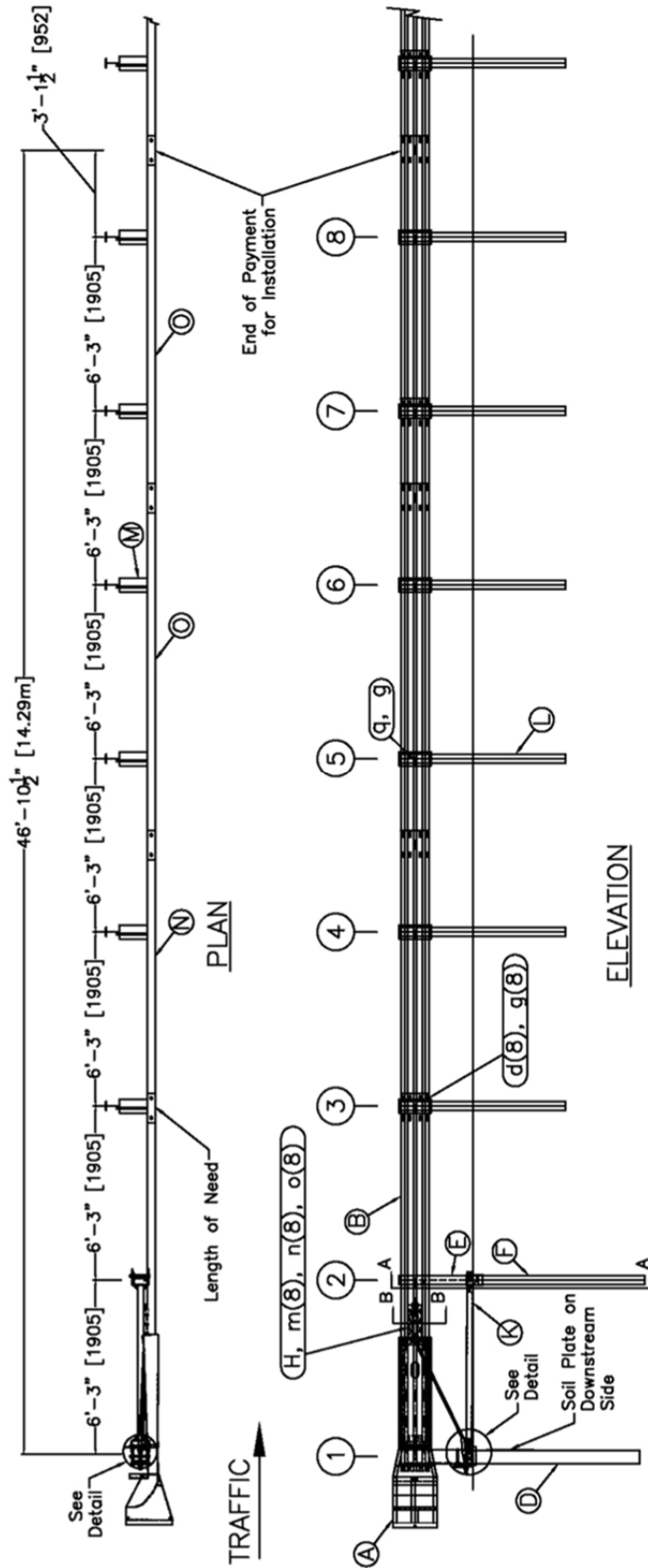

Post #3 and beyond are W6 x 9# or W6 x 8.5# x 6'-0" long standard steel guardrail posts with 8" or 12" blockouts to match the MGS W-Beam barrier that the specifying agency has shown downstream of the MSKT.

See page 5 for the Bill of Materials showing components used with either 8" or 12" blockouts.

**Pay limits for the MSKT terminal vary from State to State. See page #4. Pay limits may be 46'-10 1/2" or 53'-1 1/2" for Test Level 3.**

Figure 1.

### 3.3 Optional Flared Installation for MSKT

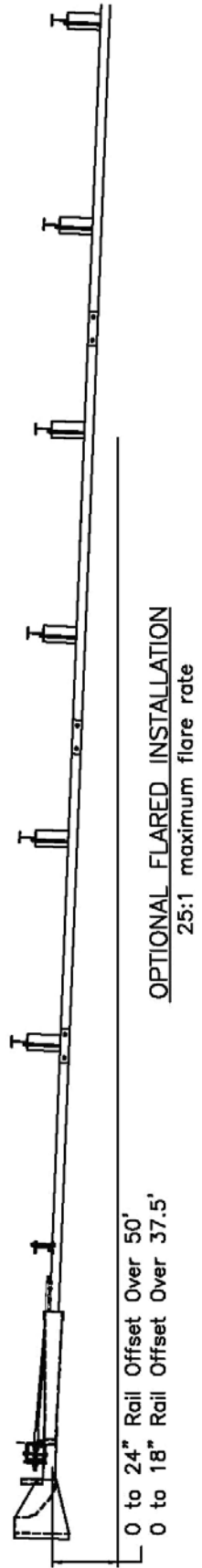
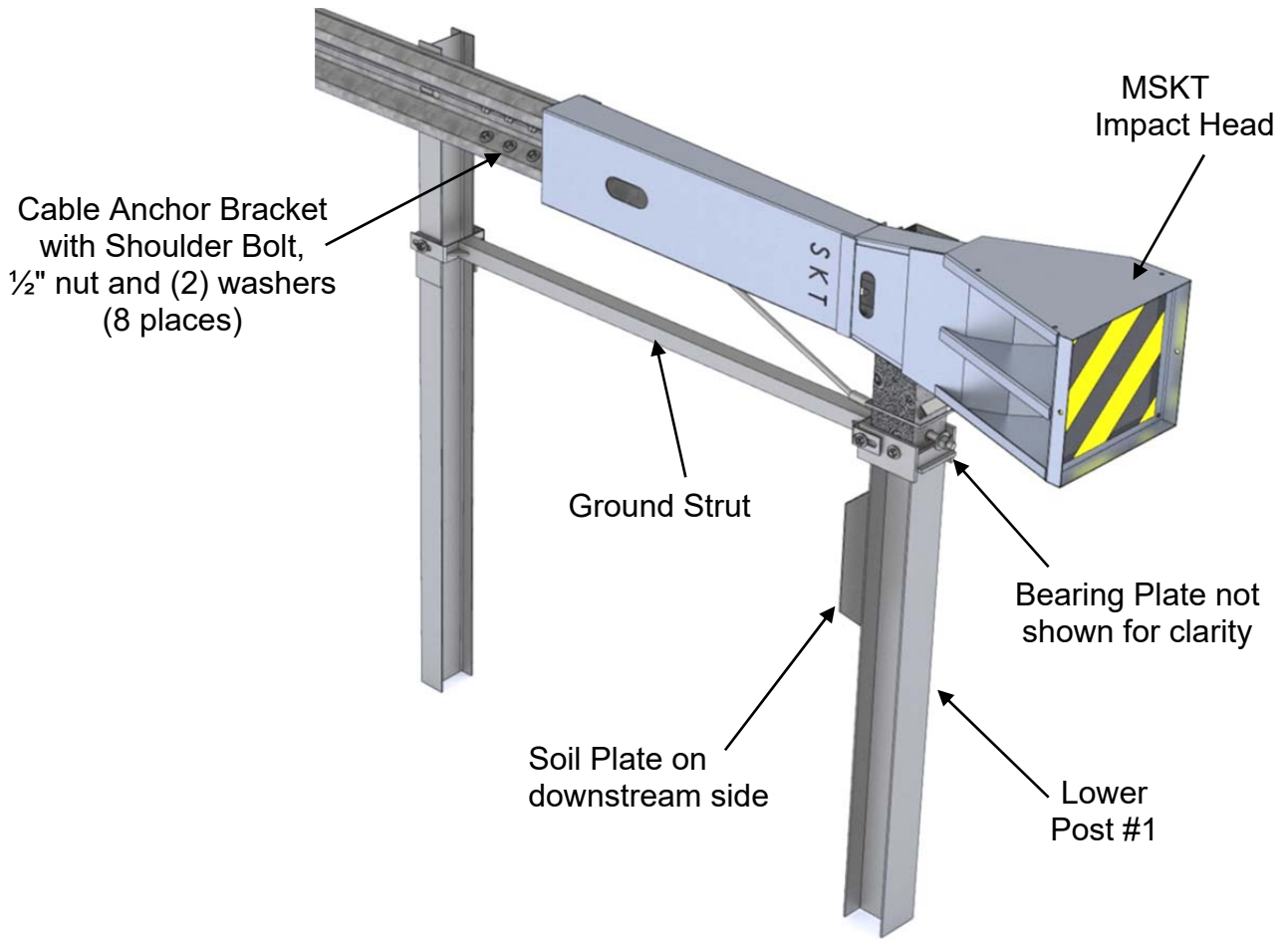
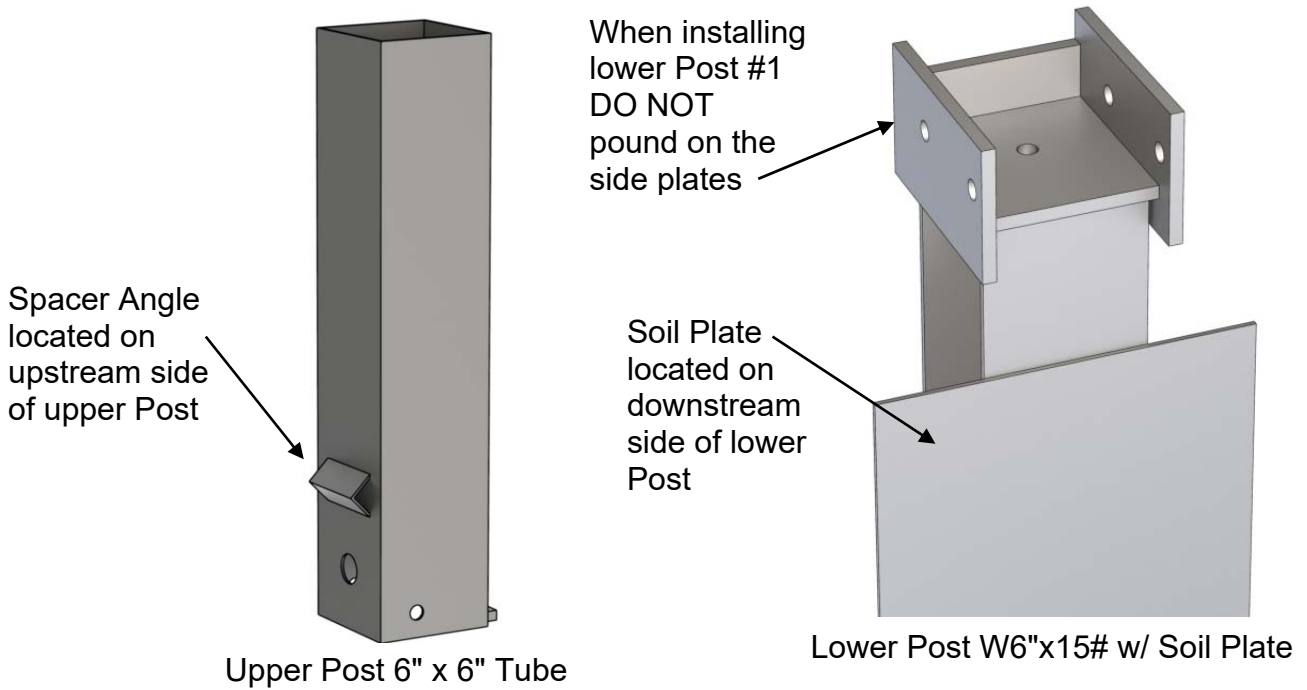

Figure 2.

### 3.4 View of MSKT Steel End Post #1



**NOTE:** Be sure the 5/8" x 9" hex bolt at Hinged Post #1 is on the upstream side of the post.



**Figure 3.**

### 3.5 Post #1 Connection Detail for MSKT

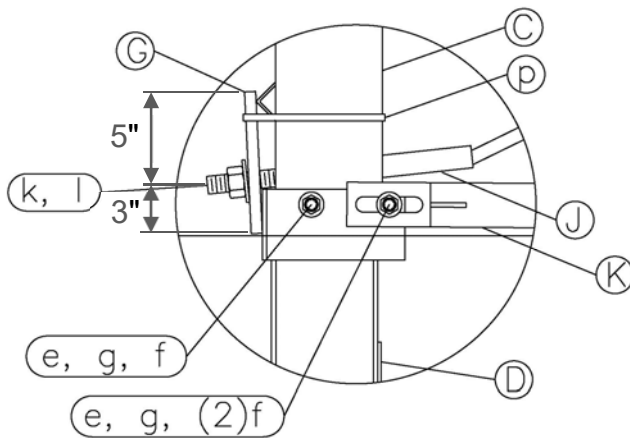
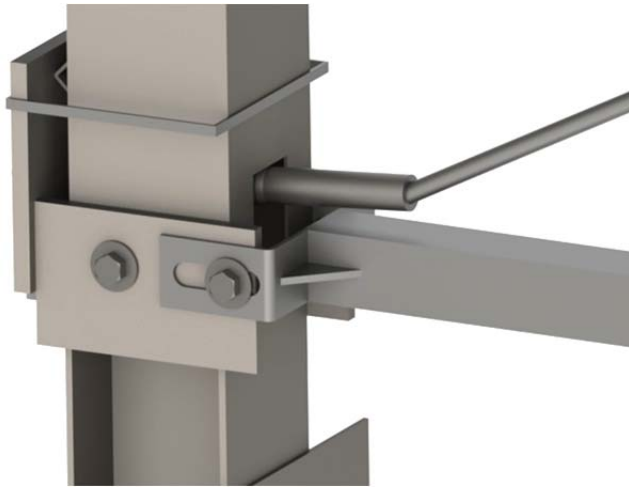

C	Upper Post #1 Tube 6" x 6"
D	Lower Post #1 W6" with Soil Plate
G	Bearing Plate 8" x 8"
J	Cable Anchor Assembly
K	Ground Strut
e	5/8" x 9" Hex Bolts
f	5/8" Washers
g	5/8" Nuts
k	1" Nut
l	1" Washer
p	Bearing Plate Retainer Tie

Post #1 Connection Detail



5/8" bolt at post #1 on upstream side of the post

5/8" bolt to attach ground strut to the extended side plates of lower post #1

3/4" bolt at hinged post #2 on downstream side of the post. A 3/4" washer is not needed but may be used.

Figure 4.

### 3.6 Post #2 Connection Detail for MSKT

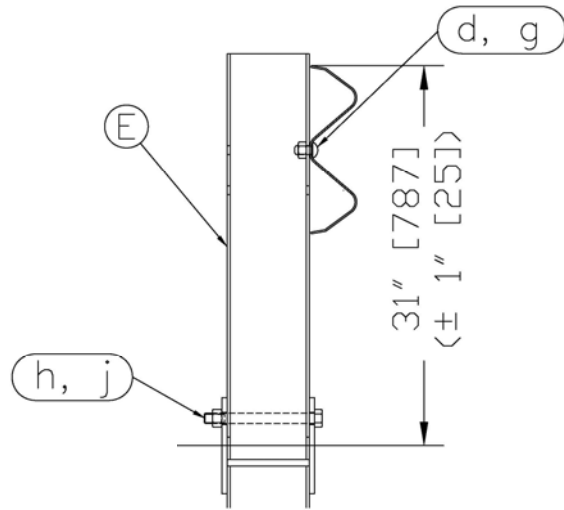
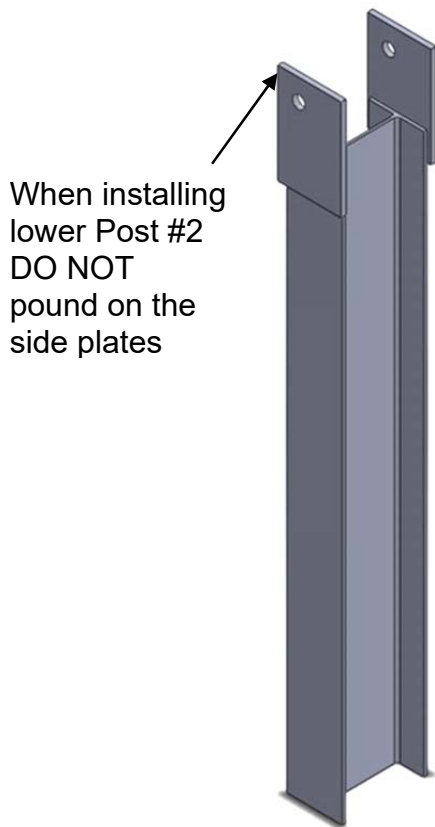

E	Upper Post #2 W6" x 8.5 #
d	5/8" x 1 1/4" Guardrail Splice Bolt
g	5/8" Nut
h	3/4" x 8 1/2" Hex Bolt
j	3/4" Nut

**NOTE:** Be sure the 3/4" x 8 1/2" hex bolt at Hinged Post #2 is on the downstream side of the post (toward post #3).

**Figure 5.**

### 3.7 Ground Strut Detail for MSKT

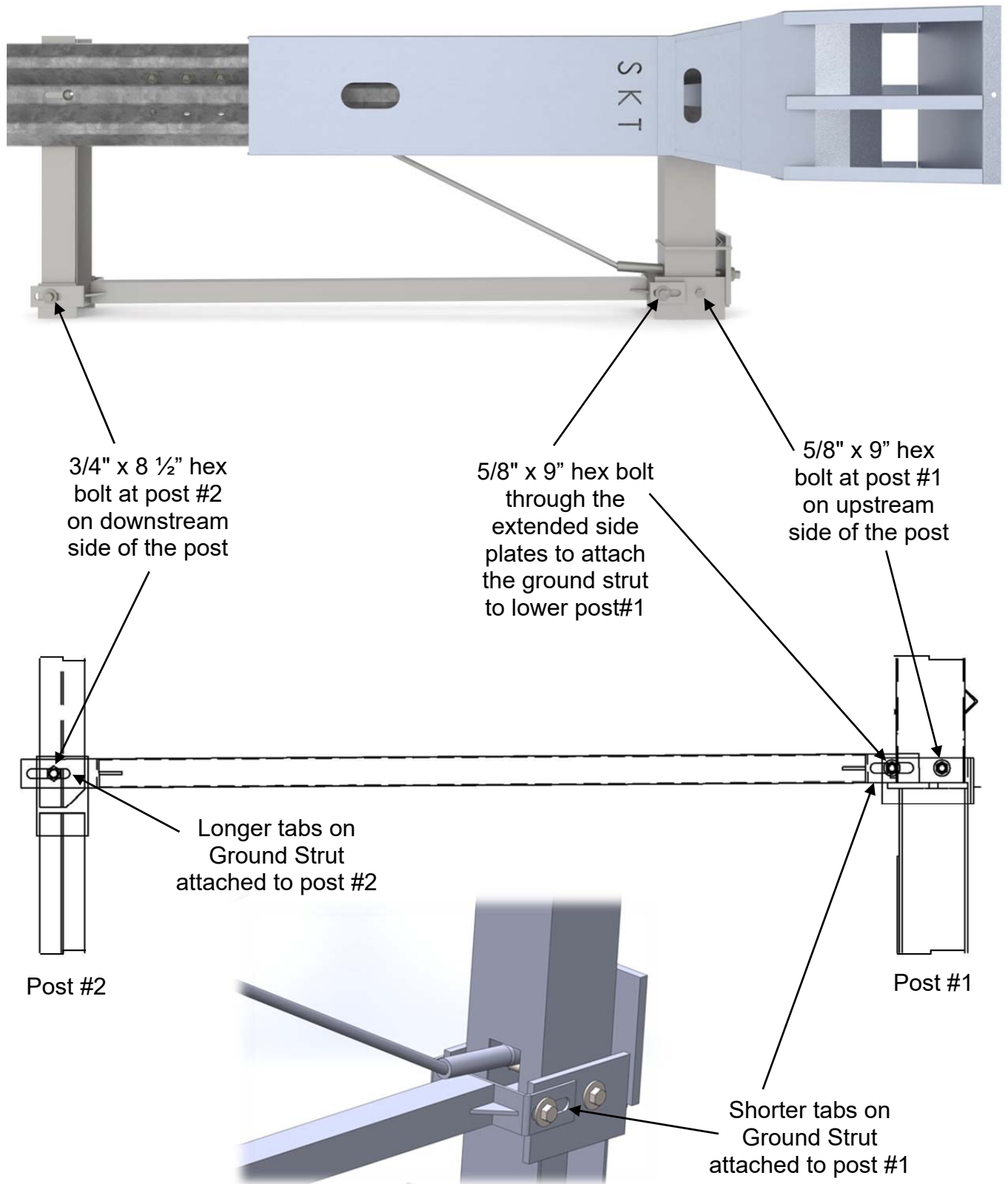
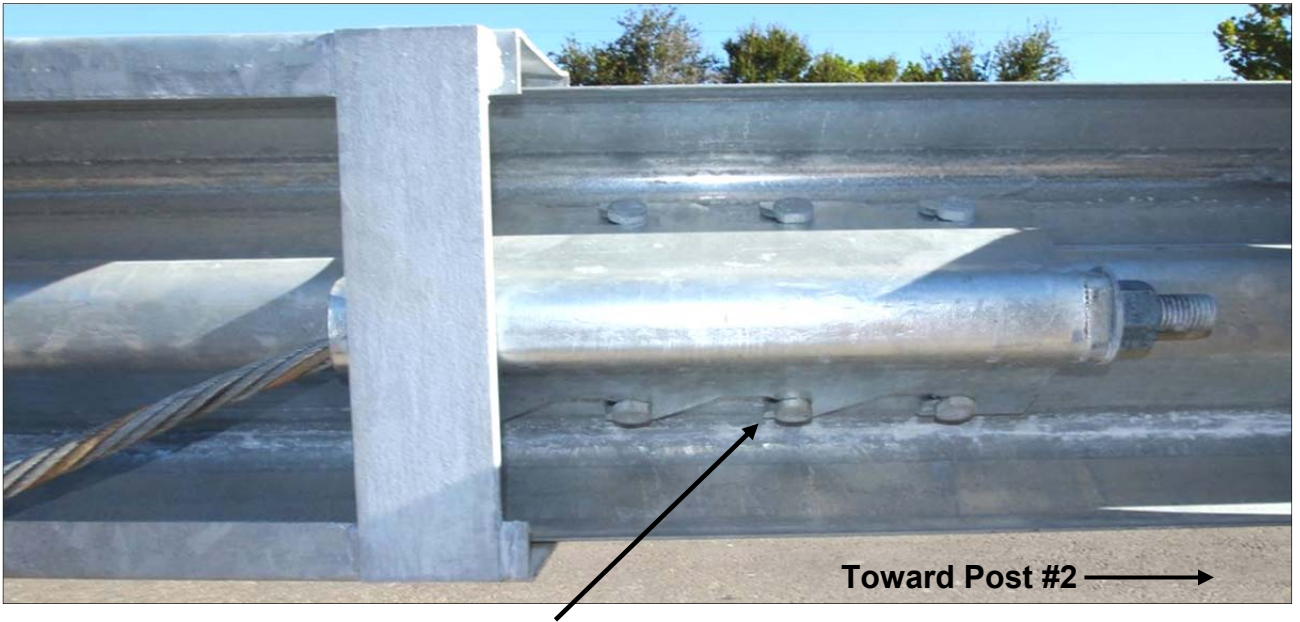
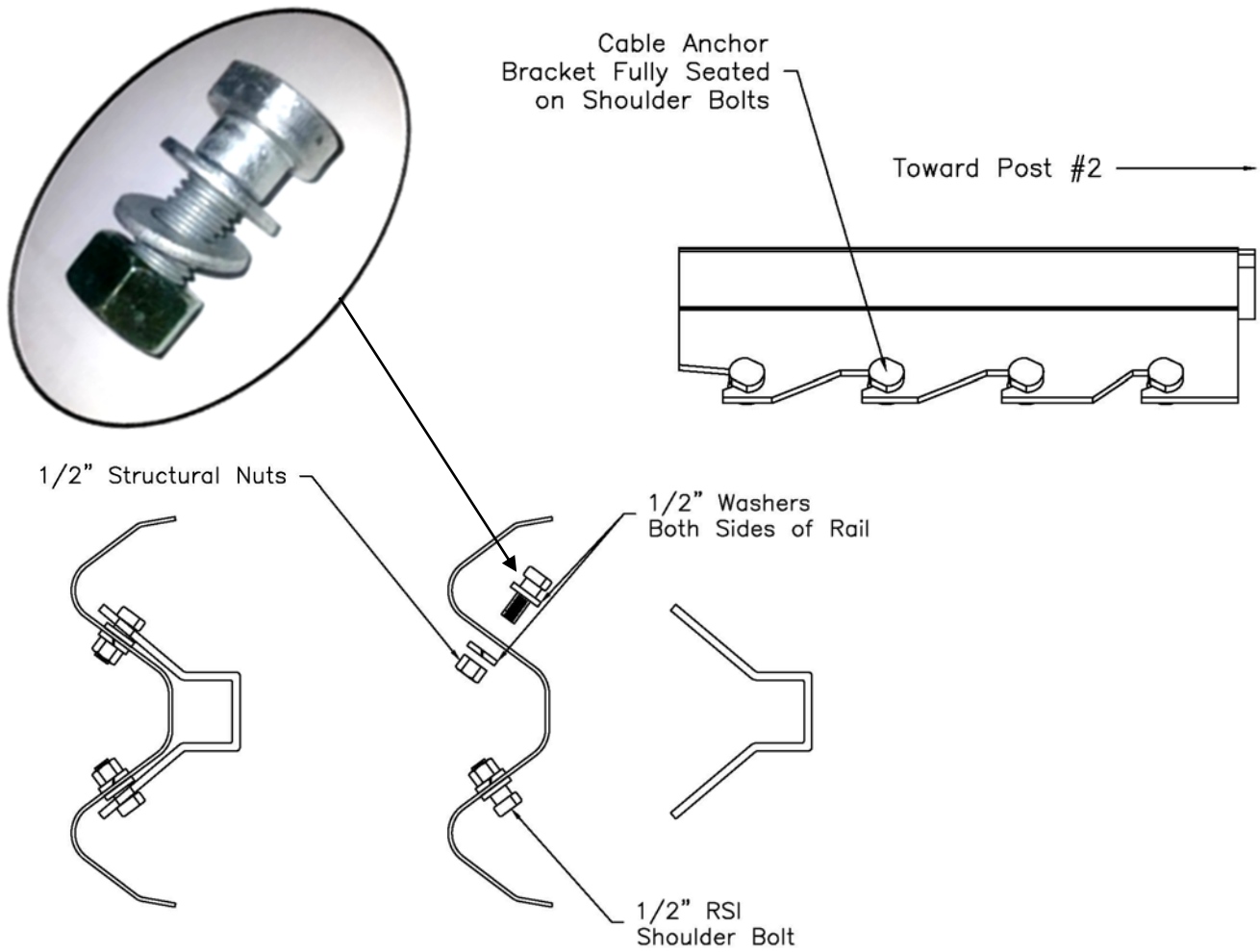

Figure 6.

### 3.8 Installation of Cable Anchor (Box) Bracket and Shoulder Bolts



It is important that the anchor bracket be fully seated on the shoulder portion of the cable anchor bolts

**Figure 7.**

### 3.9 Impact Head Connection Detail for MSKT

Note there are two sets of holes in post #1. This is a Universal Post used for both 28" & 31" rail heights. Use the top set of holes for the MSKT terminal.

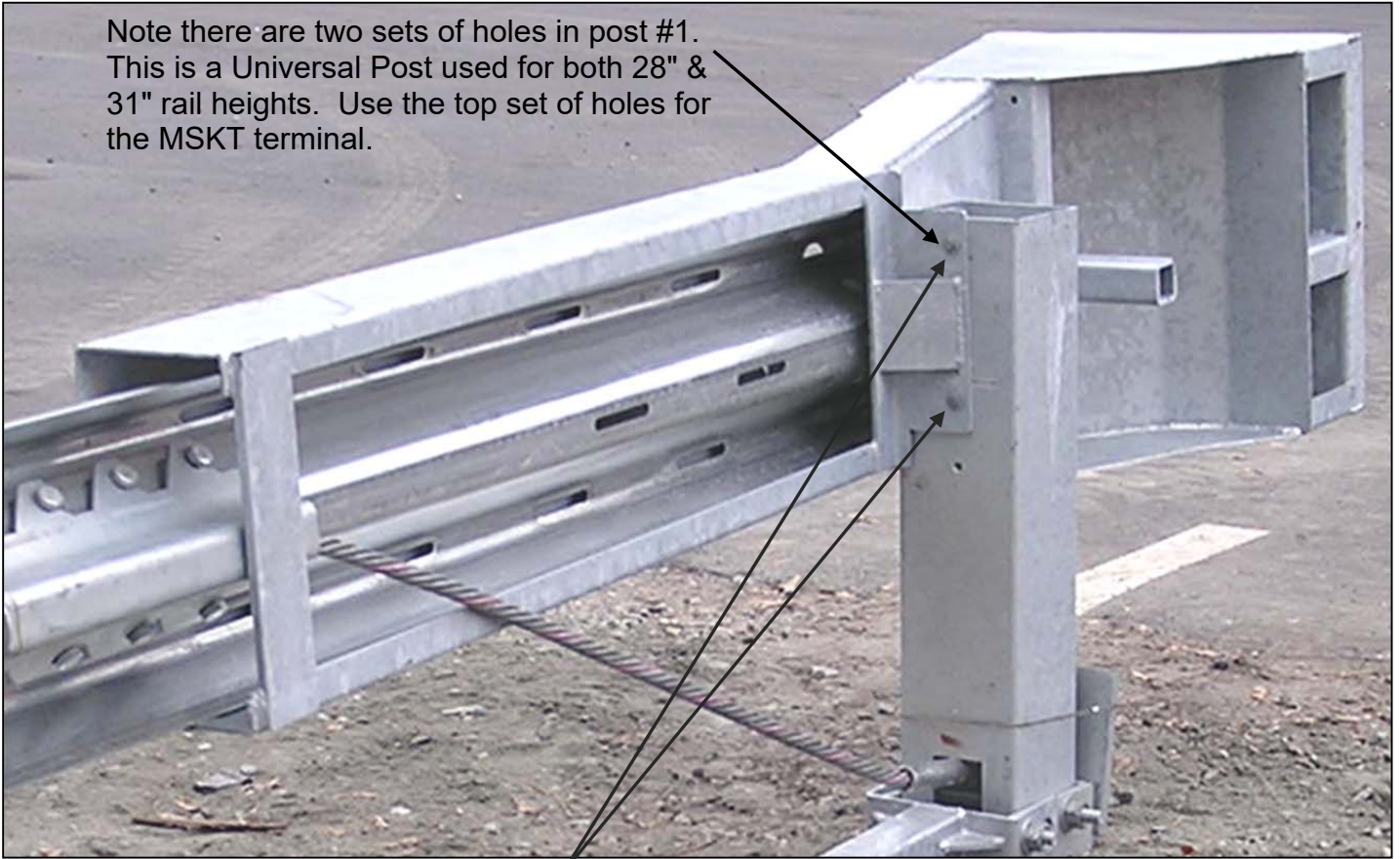

5/16" x 1" hex bolt w/ nut & (2) washers – 2 places



**Figure 8.**

### 3.10 Grading Recommendations for MSKT

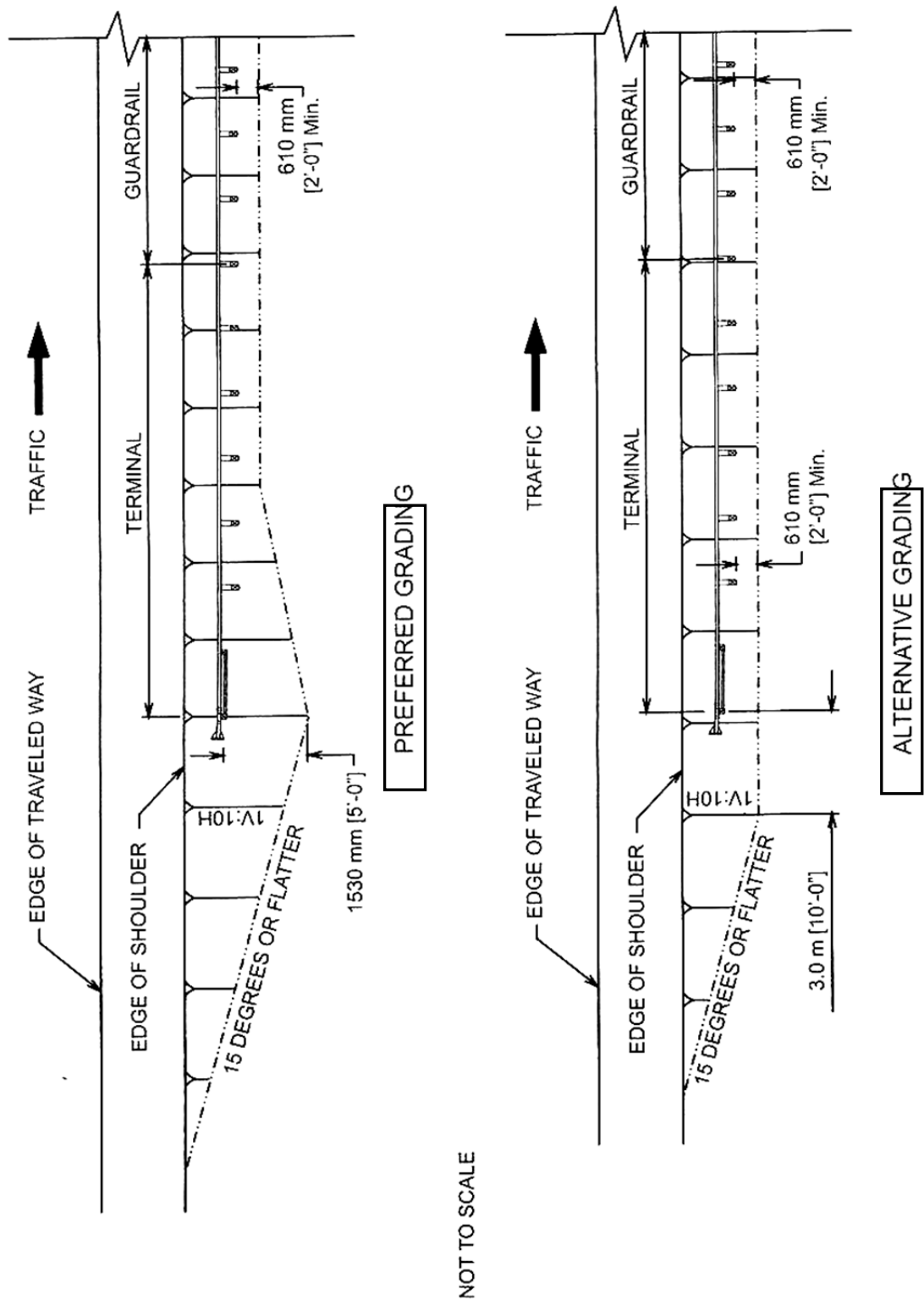

(Reference AASHTO Roadside Design Guide)

Figure 9.

# 4 Installing the MSKT

---

## 4.1 Materials

The pay limit lengths of the MSKT are described under the **General Information** section on pages 2 and 3. The Test Level 3 systems are 50'-0" long. Refer to contract plans.

## 4.2 Site Preparation

When the guardrail is installed parallel to the edge of the shoulder, for the MSKT a 25:1 (or less) flare away from the roadway is recommended so the impact head will not encroach on the shoulder thereby reducing the potential for nuisance impacts. The flare is not required and may be decreased or eliminated. See **Figure 2**.

Site grading may be necessary for installations placed beyond the edge of the shoulder to prevent the lower section of the breakaway Steel Posts from extending more than 4" above the ground. Refer to **Figure 9** for the grading recommendations.

## 4.3 Tools Required

The tools required for installation of the MASH MSKT system are the same as those used to install standard highway guardrails, including sockets/wrenches, a drill, and other equipment such as augers, tampers, & post pounders commonly used in driving guardrail posts.

## 4.4 Installation Procedures

Begin the installation at the downstream end of the MSKT to ensure that the terminal matches up with the standard downstream section of guardrail. The major steps in the installation of the terminal are as follows:

- Install standard steel guardrail posts #3 and beyond.
- Install breakaway steel end posts #1 and #2.
- Install ground strut.
- Install guardrail. All posts are spaced at 6'-3".
- Install cable anchor bracket. Special shoulder bolts are required.
- Install the MSKT impact head.
- Install cable assembly.

#### **4.4.1 Installing Standard Steel Guardrail Posts #3 and Beyond**

All posts at locations #3 and beyond are W6x9# or W6x8.5# x 6'-0" long standard steel guardrail posts spaced at 6'-3" centers. Blockouts are 8" or 12". The finished guardrail height should be approximately 31" ± 1" above the edge of the shoulder or the finished grade.

For the MSKT, if the pay limit for the system is 50'-0" long, posts #3 - #8 will be standard steel guardrail posts. See **Figure 1**.

The acceptable pay limit lengths are described under the **General Information** section on pages 2 and 3. *NOTE: The MGS barrier requires mid-span splices between posts. Pay limits of the terminal often vary by 3'- 1½" (depending on rail lengths). See page 4 for allowable rail lengths and pay limits.*

#### **4.4.2 Installing Breakaway Steel End Posts #1 and #2**

Posts #1 & #2 are hinged steel posts. These bolted posts must have the lower section installed before attaching the top section. Be sure an adequate driving cap is used so the welds on the cap plate of post #1 and the welds on the side plates of post #2 are not damaged. The lower section of the bolted hinged steel posts should not be driven with the upper post attached. Posts #1 & #2 are spaced at 6'-3" centers.

Upper and lower Post #2 are W6x9# or W6x8.5# sections. Bolt upper and lower post #2 together with a ¾" x 8 ½" hex bolt and nut. A ¾" washer is not needed but may be used. One end of the ground strut will be placed here. Be sure when the lower segment of the post is installed, the hinge bolt is on the downstream side of the post (opposite the impact head). Upper post #2 has an open-ended slot for the post bolt. If there are two slots, the top slot will be used to achieve the 31" rail height. Be sure slot is on the upstream side of the post (toward the impact head). See **Figure 5** for post #2 details.

Upper Post #1 is a 6" x 6" x ⅛" tube section. The post will be placed so the angle spacer is facing oncoming traffic. The bearing plate will rest on this angle spacer. Lower Post #1 is a W6x15# post with a soil plate welded to the post. Bolt upper and lower post #1 together with a ⅝" x 9" hex bolt, nut and washer. Be sure when the post is installed, the hinge bolt is on the upstream side of the post (toward the impact head). One end of the ground strut will be placed at post #1 against the extended side plates, not the post itself and will use another hex bolt. Be sure when the lower segment of the post is installed, the soil plate is on the downstream side of the post (opposite the impact head). See **Figure 4**.

The top of the lower post #1 & #2 stubs should not project more than 4" above the ground line when measured along a 5' cord, in compliance with AASHTO specifications. Site grading may be required if the top of the lower post section project more than 4" above the ground line.

For stiff soils, drill a pilot hole and force the post to the proper depth by impact or vibratory means with an appropriate driving cap. For post #1, be sure the driving cap is on top plate and not the side plates. Do not drive on the side plates of lower posts #1 & #2 as they may be damaged.

The post may also be installed by augering and backfilling if the contractor so prefers. The initial hole must be large enough to allow adequate room for proper compaction of the soil during backfill. *Care must be taken to carefully compact the backfill to prevent settlement or lateral displacement of the post.* If rock is encountered during driving or excavation, refer to appropriate State specifications for how to proceed or contact Road Systems, Inc.

### 4.4.3 Installing Ground Strut

Traditionally, ground struts have attached to posts #1 and #2 utilizing the same bolts that that hold the upper and lower post sections together. For the MSKT, that's the condition at post #2 using the  $\frac{3}{4}$ " x  $8\frac{1}{2}$ " hex bolt and nut. However, at post #1 a second  $\frac{5}{8}$ " x 9" hex bolt, hex nut, and two washers are placed through the extended side plates on lower post#1, not through the post itself. Note the ground strut is not symmetrical. The end with the longer tabs is attached at post #2 and the end with the shorter tabs is attached at post #1. See **Figure 6**.

### 4.4.4 Installing Guardrail

Attach the special length and standard length MGS W-beam guardrail sections downstream of post #3. **See page #4 for rail length options.** Attach the MSKT W-Beam guardrail end section to span from post 1 to 3 (12'-6" long rail). The Universal End Panel can be identified with eight (8) holes  $\frac{3}{4}$ " diameter to attach the cable anchor bracket and thirteen (13) slots. Ten (10) slots  $\frac{1}{2}$ " x 4" are in the corrugations of the rail and three (3) slots  $\frac{1}{2}$ " x 4" are in the valley of the rail.

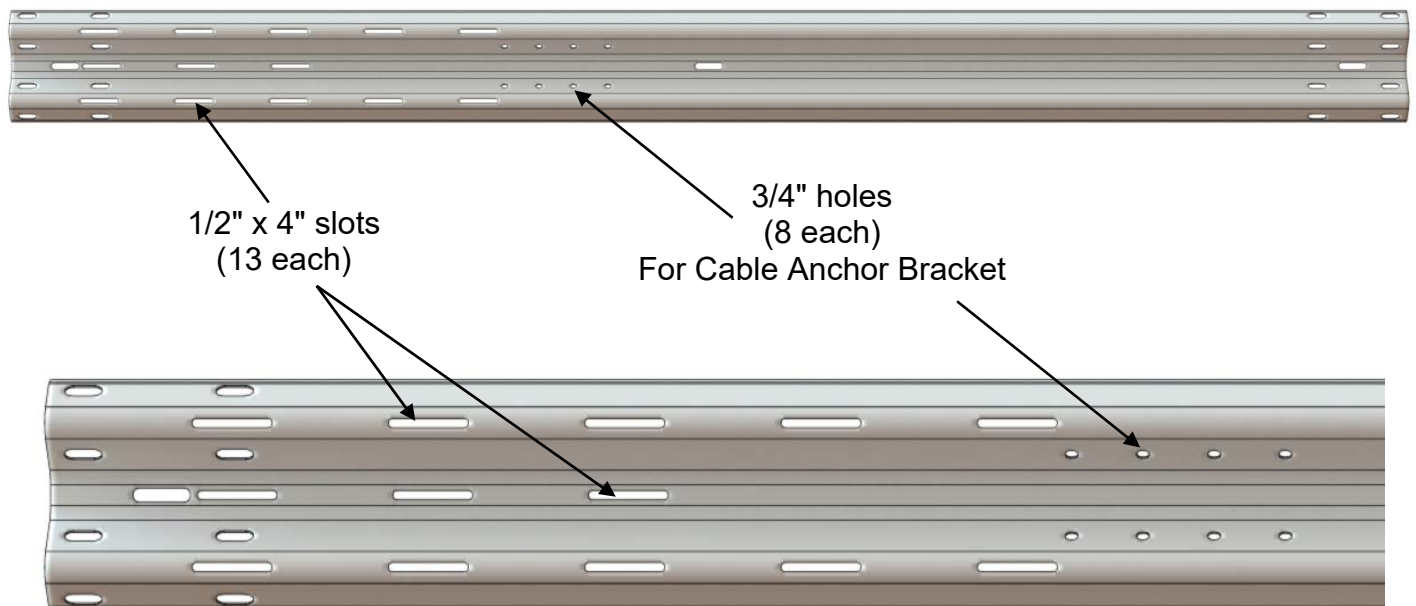

After the special length rail panel, the other W-Beam MGS railing sections in the terminals shall be the same as those used in MGS highway guardrail with 6'-3" post spacing. Rail sections may be 12'-6" or 25'-0" long. All rails are spliced with  $\frac{5}{8}$ " x  $1\frac{1}{4}$ " H.G.R. (Highway Guard Rail) bolts and  $\frac{5}{8}$ " H.G.R. nuts.

The MSKT rails are to be attached to posts and blockouts at post locations #3 and beyond with  $\frac{5}{8}$ " x 10" H.G.R. bolts and nuts. *There is no blockout used on posts #1 & #2.* The end rail for the MSKT is attached to post #2 with a  $\frac{5}{8}$ " x  $1\frac{1}{4}$ " H.G.R. bolt and nut.

**A post bolt is never used at post #1.**

**NOTE:** All of the W-Beam railing within the MSKT terminal must be straight. Radius rail within the 50-ft TL-3 terminal is not permitted. Radius rail may begin beyond post #9.

#### ***4.4.5 Installing Cable Anchor Bracket***

The eight ½" cable anchor bracket shoulder bolts are attached to the W-beam guardrail end section with two ½" structural washers, one on each side of the guardrail, and a ½" structural nut. Be sure the shoulder bolts are placed with the shoulders of the bolts installed on the backside of the guardrail, away from traffic, as shown in **Figure 7**.

For ease of installation, attach the cable anchor bracket shoulder bolts to the rail "finger tight" only. Then align the openings on the cable anchor bracket with the shoulder bolts and tap the cable anchor bracket onto the shoulder portion of the bolts using a hammer. Tighten the bolts with a wrench when the bracket is in place. The welded plate on the cable anchor bracket should be toward Post #2, as shown in **Figure 7**. Be sure the bracket is fully seated on the shoulder portion of the bolts.

#### ***4.4.6 Installing the MSKT Impact Head***

The eight cable anchor bracket shoulder bolts & the cable anchor bracket should be attached to the W-beam guardrail end section prior to attaching the MSKT impact head to the first post. The MSKT impact head will be installed with the rail exit slot on the back side away from traffic.

Place the impact head with the feeder guide chute over the end of the W-beam guardrail. The impact head should be positioned so that the protruding tube (called the post breaker) is on the backside of the guardrail, away from traffic as shown in **Figures 4 & 8**. Slide the impact head forward until the post angle attachments on the impact head are aligned with the holes in post #1 (6" x 6" x ½" tube) as shown in **Figure 8**. There are two sets of holes in post #1. This is a Universal Post. Use the top set of holes for the 31" MSKT terminal. The bottom set of holes are used for 28" rail heights. Attach the impact head to the first post with two 5/16" x 1" hex bolts, nut and (2) washers, one each for the top and bottom post angle attachments.

**NOTE:** It is recommended that the face of the impact head be delineated with an object marker that meets State specifications for better night visibility. However, the impact face object marker may not be included as part of the shipped materials for the terminal unless specifically requested in the contract plans or by the customer.



#### 4.4.7 Installing Cable Assembly

Place the cable assembly through the cable anchor bracket and through the base of post #1. Note that for the MSKT, the cable assembly is fed inside through the feeder chute of the impact head.



Place the bearing plate at the base of post 1 with the 5" dimension up and 3" dimension down. The bearing plate will rest on the angle spacer welded to post #1. See **Figure 4**. Secure the bearing plate with a retainer/tie to prevent the plate from rotating. Secure both ends of the cable assembly with a 1" hex nut and washer. While tightening the cable, use a hammer to tap the cable anchor bracket from the downstream end to ensure that it is securely interlocked with the shoulder bolts. Restrain the cable at the end being tightened with vice grips or channel lock pliers to avoid twisting the cable.

Upon completion of the installation, the cable should be taut and the cable anchor bracket should be fully seated on the shoulder portion of the cable anchor bolts.

**NOTE:** It is very important that the cable anchor bracket be fully seated on the shoulder portion of the cable anchor bolts as shown in **Figure 7**.

# 5 MSKT-SP-MGS (MSKT) Inspection Checklist

---

State: \_\_\_\_\_

Date: \_\_\_\_\_

Project #: \_\_\_\_\_

Location: \_\_\_\_\_

- The rail height is in accordance with the contract plans. This should be 31" ±1" above the edge of the finished grade.
- There is no radius rail within the MSKT 50'-0" length (TL-3).
- The end rail panel is not attached to the post at post location #1.
- The end rail panel has ½" x 4" slots and all rails are lapped in the proper direction.
- The end rail panel is 12'-6" long. The second rail must be 9'-4 ½" long to establish the mid-span splices between posts. A second rail length of 15'-7 ½" may also be used.
- The ¾" x 8 ½" hinge bolt at post #2 is on the downstream side of the post.
- The ⅝" x 9" hinge bolt at post location #1 is on the upstream side of the post.
- The lower stub at posts #1 and #2 do not protrude more than 4" above the ground line (measured by the AASHTO 5' cord method). Site grading may be necessary to meet this requirement.
- At post #2, the open-ended slot(s) at the post bolt is on the upstream side of the post.
- Standard steel W6x9# x 6'-0" guardrail posts are used at post locations #3 and beyond. Timber CRT posts may also be used at post locations #3 and beyond.
- All posts within the MSKT are spaced at 6'-3" centers.
- The blockouts are 8" or 12" deep depending on State or local agency standards.
- The MSKT impact head does not encroach on the shoulder.
- The two 5/16" x 1" hex bolts holding the impact head to post #1 are secured.
- The 8" x 8" bearing plate at post #1 is correctly positioned with the 5" dimension up (resting on the angle spacer) and 3" dimension down. The anchor cable is taut and correctly installed. A retainer/tie has been placed over the bearing plate to prevent rotation.
- A ground strut is secured between posts #1 & #2 using the ¾" x 8 ½" hinge bolt at post #2 and a second ⅝" x 9" hex bolt at post location #1.
- The cable anchor bracket shoulder bolts are properly attached to the W-Beam guardrail and the cable anchor bracket is fully seated on the shoulder portion of the bolts.
- If the posts were augered, the backfill material around the posts is properly compacted.
- No washers are used on the face of the rail except at the cable anchor bracket bolts.
- The finished installation is in accordance with all specific State DOT guidelines.

Additional notes:

\_\_\_\_\_  
\_\_\_\_\_

Inspection performed by: \_\_\_\_\_

## Inspection (continued)

As with all roadside safety products, guardrail terminals require inspection to be sure they are in working order. The appropriate authorities should have inspection programs in place and track accidents to assure adequate repairs are made. Regular inspections of MSKT systems should be made based on site conditions, traffic volumes, and crash history.



## 6 Repairing the MSKT

### Equipment Needed for Repair Operation

- Acetylene torch to metal saw cut or burn off the damaged rail,
- Heavy duty chain to remove the impact head may be required,
- Tools used to install standard highway guardrails, including sockets & wrenches, etc.,
- Vice grip or channel lock pliers,
- Sledge hammer.

Be sure proper traffic control is deployed to protect workers and motorists. Follow the requirements shown in the *Manual on Uniform Traffic Control Devices (MUTCD)*.

### General Repair Procedures

After an end-on impact occurs with the MSKT, it will require replacement of the first 12'-6" end section of rail and any other damaged rail section(s) and any damaged post(s). For a traffic face impact downstream of the impact head, the damage will typically be to the downstream rail section(s) and associated posts.

The general step-by-step procedure for repairing a damaged terminal is as follows:

- (1) Check the impact head for damage.
- (2) Check the cable assembly for damage. The cable anchor bracket, bearing plate, nuts, washers, and the special cable anchor bracket shoulder bolts may be reusable.
- (3) Check the number of broken posts and blockouts that need to be replaced, along with any damaged bolts. Inventory and pick up the reusable parts.
- (4) Torch or cut off the kinked rail at the exit opening near the outlet of the impact head. Because of the open throat configuration, the impact head may be able to be removed by hand at this point. If not, then hook up a chain attachment through the opening behind the impact plate of the impact head. Pull the impact head off the rail with the chain attached to a truck frame with the W-beam guardrail still attached to the downstream guardrail posts.
- (5) Disconnect and remove the damaged rail from the posts.
- (6) Remove the damaged posts. Hinged post #2 can be unbolted. Remove the standard steel "SP" standard guardrail posts.
- (7) Reinstall the system following the procedures listed in this manual.



# 7 Allowable Options for the MSKT

The MSKT is an SP (Standard Steel Post W6 x 9# or W6 x 8.5# x 6-ft at post locations 3-8) Test Level 3 system. These are the FHWA letters and allowable options for the MSKT:

- CC-126 – MSKT Test Level 3 (06/10/16)
  - CC-126A – with 12" deep blockouts or 8" blockouts (01/24/17)
  - \*\* • CC-126B – with 15'-7 1/2" long panel in either of two locations (See notes on page 4)
  - CC-126C – with wood CRT posts at locations 3-8 (12/27/16)
  - CC-126D – Test Level 2 (03/15/17)
  - CC-126E – with 2-ft offset (01/24/17)
  - CC-126F – powder coated (12/27/16)
  - CC-130 – use of MSKT impact head on NCHRP 350 SKT (10/03/16)
- \*\* FHWA letter was written but not signed or issued. See notes on page 4.

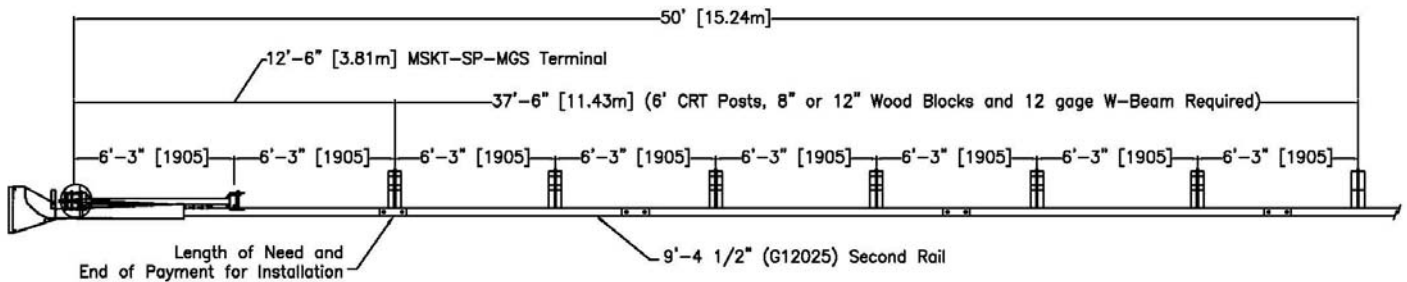

## MSKT with Wood CRT Posts at Locations 3-8

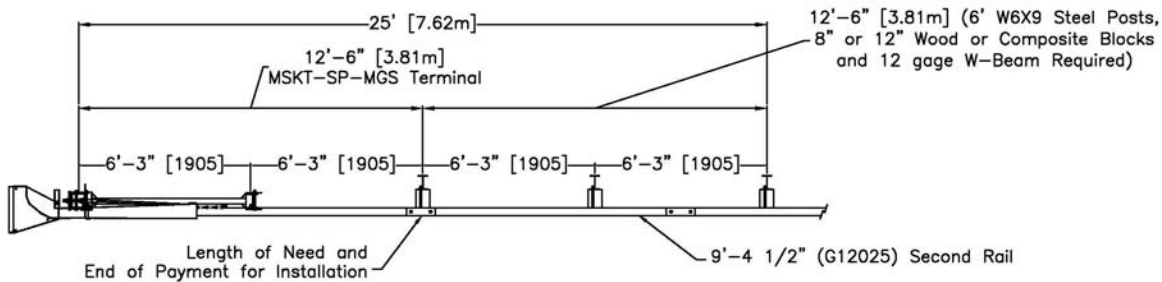

## MSKT Test Level 2

