

Assembly Instructions for

MFLEAT MASH Flared Terminal for 31" MGS (Midwest Guardrail System)



ROAD SYSTEMS, INC.

P. O. Box 2163

Big Spring, Texas 79721

Phone: (432) 263-2435 FAX: (432) 267-4039

Technical Support & Marketing Phone: (330) 346-0721

Technical Support & Marketing Fax: (330) 346-0722

www.roadsystems.com

Table of Contents

	<u>Page</u>
1. General Information	2-3
2. MFLEAT and MSKT Comparison.....	4
3. Begin Assembly – Drawing & Photo Details	5
3.1 Bill of Materials for MFLEAT	5
3.2 Layout of MFLEAT System / Figure 1	6
3.3 MFLEAT Guardrail Panel Configuration / Figure 2	7
3.4 View of MFLEAT Steel End Post #1 / Figure 3	8
3.5 Post #1 Connection Detail for MFLEAT / Figure 4	9
3.6 Posts #2 and #3 Connection Detail for MFLEAT / Figure 5	10
3.7 Ground Strut Detail for MFLEAT / Figure 6	11
3.8 Installation of Cable Anchor (Box) Bracket & Shoulder Bolts / Figure 7 ..	12
3.9 Impact Head Connection for MFLEAT / Figure 8	13
3.10 Grading Recommendations for MFLEAT / Figure 9	14
4. Installing the MFLEAT	15
4.1 Materials	15
4.2 Site Preparation	15
4.3 Tools Required	15
4.4 Installation Procedures.....	15
4.4.1 Installing Standard Steel Guardrail Posts #4 and Beyond	16
4.4.2 Installing Bolted Steel Posts #1, #2 and #3	16
4.4.3 Installing Ground Strut	17
4.4.4 Installing the Two Special Length Guardrail Panels	17
4.4.5 Installing 12'-6" End panel	17
4.4.6 Installing Cable Anchor Bracket	18
4.4.7 Installing MFLEAT Impact Head	18
4.4.8 Installing Cable Assembly & MASH Bearing Plate	19
5. Inspection Checklist for MFLEAT	20
6. Repairing the MFLEAT	22
7. Allowable Options for the MFLEAT	23

1 General Information

This Installation Manual is for the MFLEAT, MASH Flared Terminal. The MFLEAT is intended for use with MASH MGS (Midwest Guardrail System) 31" tall W-Beam barrier having mid-span splices. The MFLEAT is a steel post terminal using either 8" or 12" blockouts and can be attached to steel post or wood post MGS longitudinal barriers.

The MFLEAT was designed and crash tested as a redirective gating terminal to meet the requirements of the American Association of State and Highway Transportation Officials (AASHTO) Manual for Assessing Safety Hardware (MASH) criteria Test Level 3 (100 km/hr.). The MFLEAT is eligible for Federal-aid reimbursement for use on the National Highway System. It is the responsibility of the installer to utilize a design approved by the State DOT and to follow all required State procedures and these instructions in installing the MFLEAT terminal.

This Installation Manual is divided into 7 sections

1. General Information for MFLEAT Steel Post Design.
2. MFLEAT and MSKT Comparison – This area describes the differences between the characteristics and components of the MASH flared MFLEAT system and the MASH tangent MSKT system. (page 4)
3. MFLEAT Drawing & Photo Details – This area shows a Bill of Materials and assembly details for the MFLEAT. (pages 5 - 14)
4. Installing the MFLEAT – This section gives a step-by-step procedure on the proper assembly of MFLEAT Steel Post system. (pages 15 - 19)
5. Inspection Checklist for MFLEAT – Use the checklist to inspect new installations or recently maintained/repaired installations. (pages 20-21)
6. Repairing the MFLEAT – This section gives general repair procedures for the MFLEAT Steel Post system. (page 22)
7. Allowable Options for the MFLEAT – This section lists the FHWA letter showing allowable options for the MFLEAT. (page 23)



General Information (continued)

The MFLEAT is a flared redirective and gating single-sided W-Beam terminal with a length-of-need (LON) point at post #4. The MFLEAT uses 8" or 12" offset blocks at posts #4 to #8 and is designed to be attached to 31" tall strong post W-Beam guardrail systems (using 8" or 12" offset blocks) that have been tested and accepted under the MASH crash testing criteria. The terminal has a length of 36'-5½" and a straight flared length of 39'-7" for Test Level 3.

If the MFLEAT is intended to attach to a rigid barrier, a transition to gradually increase the stiffness in the W-Beam shall be required. If the MFLEAT is intended to attach to a 28" tall W-Beam guardrail system with rail splices on the post, a transition to lower the rail height and move the rail splice to the post is required. Check the State standard sheets or contract plans for placement.

The MFLEAT is a flared terminal with a fixed 3-ft offset. For TL-2 applications, the system layout does not change. Design, selection & placement of the MFLEAT system shall conform to the *AASHTO Roadside Design Guide* and the details shown on the contract plans. The assembly of the MFLEAT shall be in accordance with the recommendations of Road Systems, Inc.

NOTE: Anywhere a W6x9# x 6'-0" standard guardrail post is mentioned throughout this manual, a W6x8.5# x 6'-0" standard guardrail post is equivalent and is permitted.

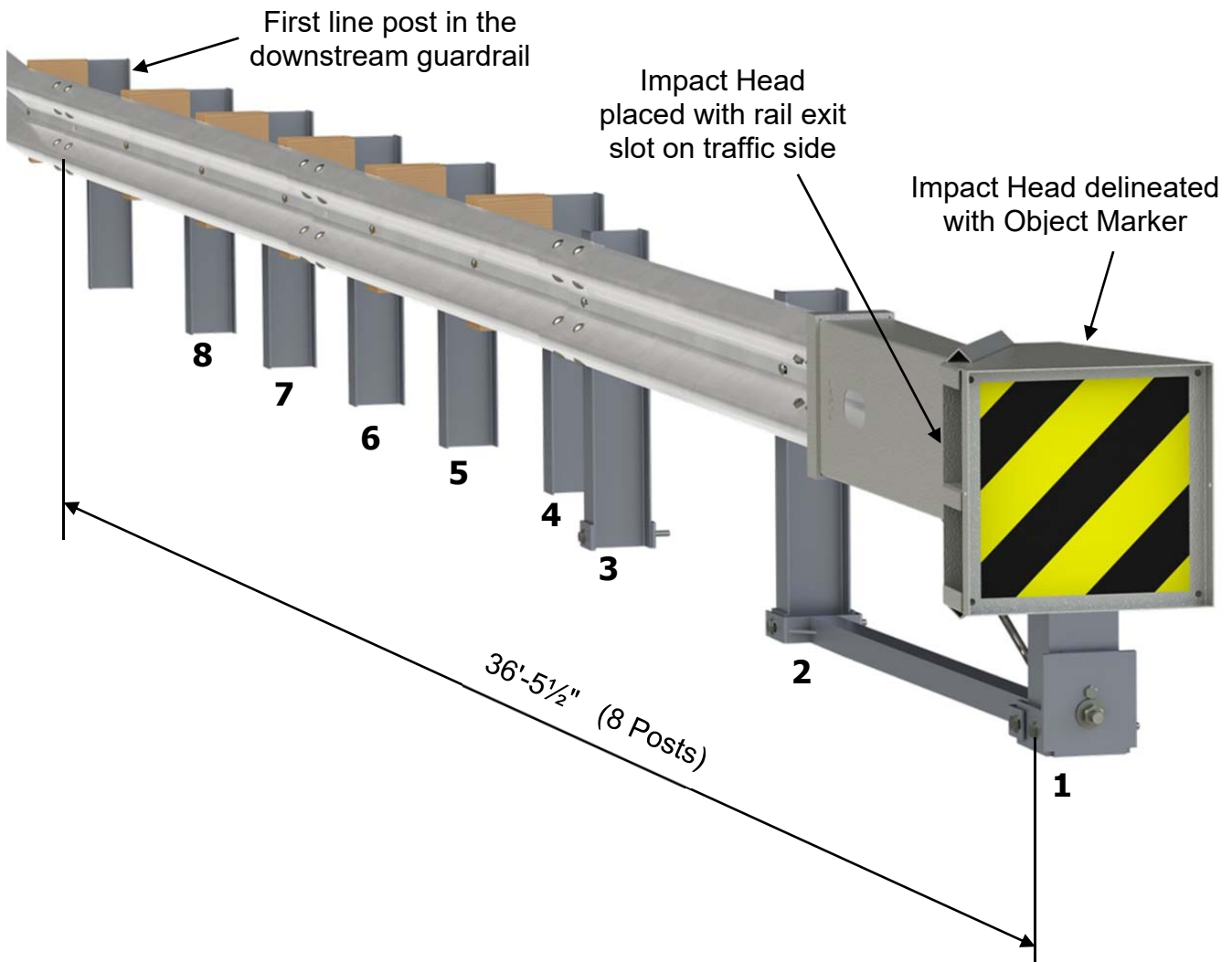

2 MFLEAT and MSKT Comparison

The **MFLEAT** is a *flared* energy absorbing terminal. Its characteristics include:

- 39'-7" straight flared length up to post #9.
- 3-ft fixed offset over the 39'-7" length.
- Three steel bolted posts (#1, #2, #3).
- The first 2 posts are spaced @ 6'-3" and the remaining 5 posts spaced @ 4'-2".
- Rail lengths: 12'-6" end rail, 10'-5" second rail, 13'-6 ½" third rail.
- Length of Need point at post #4.

The **MSKT** is a *tangent* energy absorbing terminal. Its characteristics include:

- 50'-0" straight length up to post #9.
- No offset is required but may be flared up to 2'-0" over the 50-ft length.
- Two steel bolted posts (#1 and #2).
- All posts spaced @ 6'-3".
- Rail lengths: 12'-6" end rail, 9'-4 ½" second rail, 12'-6" third & fourth rail (or 25-ft).
- Length of Need point at post #3.

MFLEAT and MSKT **share the following components:**

- First 12'-6" End Rail section
- Cable Anchor Bracket with Shoulder Bolts
- Anchor Cable
- Ground Strut
- Lower Posts 2 and 3 (MFLEAT) same as MSKT Lower Post #2
- Steel Line Posts (MFLEAT 4-8 same as MSKT 3-8)
- Blockouts (8" or 12")
- All hardware (Retainer Tie eliminated from MFLEAT because of modified cap plate on Lower Post #1 and new Bearing Plate)

MFLEAT **components that are different** than MSKT:

- MFLEAT Impact Head
- MFLEAT second and third W-Beam Rails
- Upper Post #1
- Lower Post #1 has an extended cap plate which provides a "shelf" for the Bearing Plate to rest on
- Upper Post #2 & #3 for MFLEAT has removed the lower open-ended slot that was used for 28" rail heights (this post may be used on MSKT)
- MASH Bearing Plate
- 5/8" x 5" full thread retention bolt w/ nut added to MFLEAT Bearing Plate

3 Begin Assembly – Drawing & Photo Details

3.1 Bill of Materials for MFLEAT with 8" and 12" blockouts

ITEM	QTY	BILL OF MATERIALS	ITEM NO.
A	1	FLEAT IMPACT HEAD	MF3000
B	1	FLEAT ANCHOR RAIL 12'-6"	SF1303
C	1	FLEAT SECOND RAIL 10'-5"	F1324
D	1	FLEAT THIRD RAIL 13'-6 1/2"	F1334
E	1	FIRST POST TOP (6X6X $\frac{1}{8}$ " Tube)	MP1A
F	1	FIRST POST BOTTOM (6' W6X15)	MP1B
G	1	GROUND STRUT	MS785
H	2	HINGE POST UPPER	MHP2A
J	2	HINGED POST LOWER	HP2B
K	5	STEEL LINE POST 6'	P621
L	1	MASH BEARING PLATE	ME750
M	1	CABLE ANCHOR BOX	S760
N	1	BCT CABLE ANCHOR ASSEMBLY	E770
O	5	RECYCLED PLASTIC BLOCK OR EQUIV.	CBSP-14
HARDWARE (ALL DIMENSIONS IN INCHES)			
a	2	5/16 x 1 HEX BOLT GRD 5	B5160104A
b	4	5/16 WASHER	W0516
c	2	5/16 HEX NUT	N0516
d	18	5/8 x 1 1/4 SPLICE BOLT	B580122
e	2	5/8 x 9 HEX BOLT GRD 5	B580904A
f	5	5/8 x 10 H.G.R. BOLT	B581002
g	3	5/8 WASHER	W050
h	25	5/8 H.G.R NUT	N050
j	1	5/8 x 5" BOLT FULL THREAD GRD A449	B580504A
k	1	5/8 HEX NUT	N055
l	2	3/4 x 8 1/2 HEX BOLT GRD A449	B340854A
m	2	3/4 HEX NUT	N030
n	2	1 ANCHOR CABLE HEX NUT	N100
o	2	1 ANCHOR CABLE WASHER	W100
p	8	1/2 RSI SHOULDER BOLT W/WASHER	SB12A
q	8	1/2 STRUCTURAL NUT	N012A
r	8	1/2 STRUCTURAL WASHER	W012A

Bill of Materials for MFLEAT with 8" blockouts

ITEM	QTY	BILL OF MATERIALS	ITEM NO.
A	1	FLEAT IMPACT HEAD	MF3000
B	1	FLEAT ANCHOR RAIL 12'-6"	SF1303
C	1	FLEAT SECOND RAIL 10'-5"	F1324
D	1	FLEAT THIRD RAIL 13'-6 1/2"	F1334
E	1	FIRST POST TOP (6X6X $\frac{1}{8}$ " Tube)	MP1A
F	1	FIRST POST BOTTOM (6' W6X15)	MP1B
G	1	GROUND STRUT	MS785
H	2	HINGE POST UPPER	MHP2A
J	2	HINGED POST LOWER	HP2B
K	5	STEEL LINE POST 6'	P621
L	1	MASH BEARING PLATE	ME750
M	1	CABLE ANCHOR BOX	S760
N	1	BCT CABLE ANCHOR ASSEMBLY	E770
O	5	RECYCLED PLASTIC BLOCK OR EQUIV.	P618
HARDWARE (ALL DIMENSIONS IN INCHES)			
a	2	5/16 x 1 HEX BOLT GRD 5	B5160104A
b	4	5/16 WASHER	W0516
c	2	5/16 HEX NUT	N0516
d	18	5/8 x 1 1/4 SPLICE BOLT	B580122
e	2	5/8 x 9 HEX BOLT GRD 5	B580904A
f	5	5/8 x 14 H.G.R. BOLT	B581402
g	3	5/8 WASHER	W050
h	25	5/8 H.G.R NUT	N050
j	1	5/8 x 5" BOLT FULL THREAD GRD A449	B580504A
k	1	5/8 HEX NUT	N055
l	2	3/4 x 8 1/2 HEX BOLT GRD A449	B340854A
m	2	3/4 HEX NUT	N030
n	2	1 ANCHOR CABLE HEX NUT	N100
o	2	1 ANCHOR CABLE WASHER	W100
p	8	1/2 RSI SHOULDER BOLT W/WASHER	SB12A
q	8	1/2 STRUCTURAL NUT	N012A
r	8	1/2 STRUCTURAL WASHER	W012A

Bill of Materials for MFLEAT with 12" blockouts

Post #4 and beyond are W6 x 9# or W6 x 8.5# x 6'-0" long standard steel guardrail posts. Blockouts are 8" or 12" deep to match the MGS W-Beam barrier that the specifying agency has shown downstream of the MFLEAT.

3.2 Layout of MFLEAT

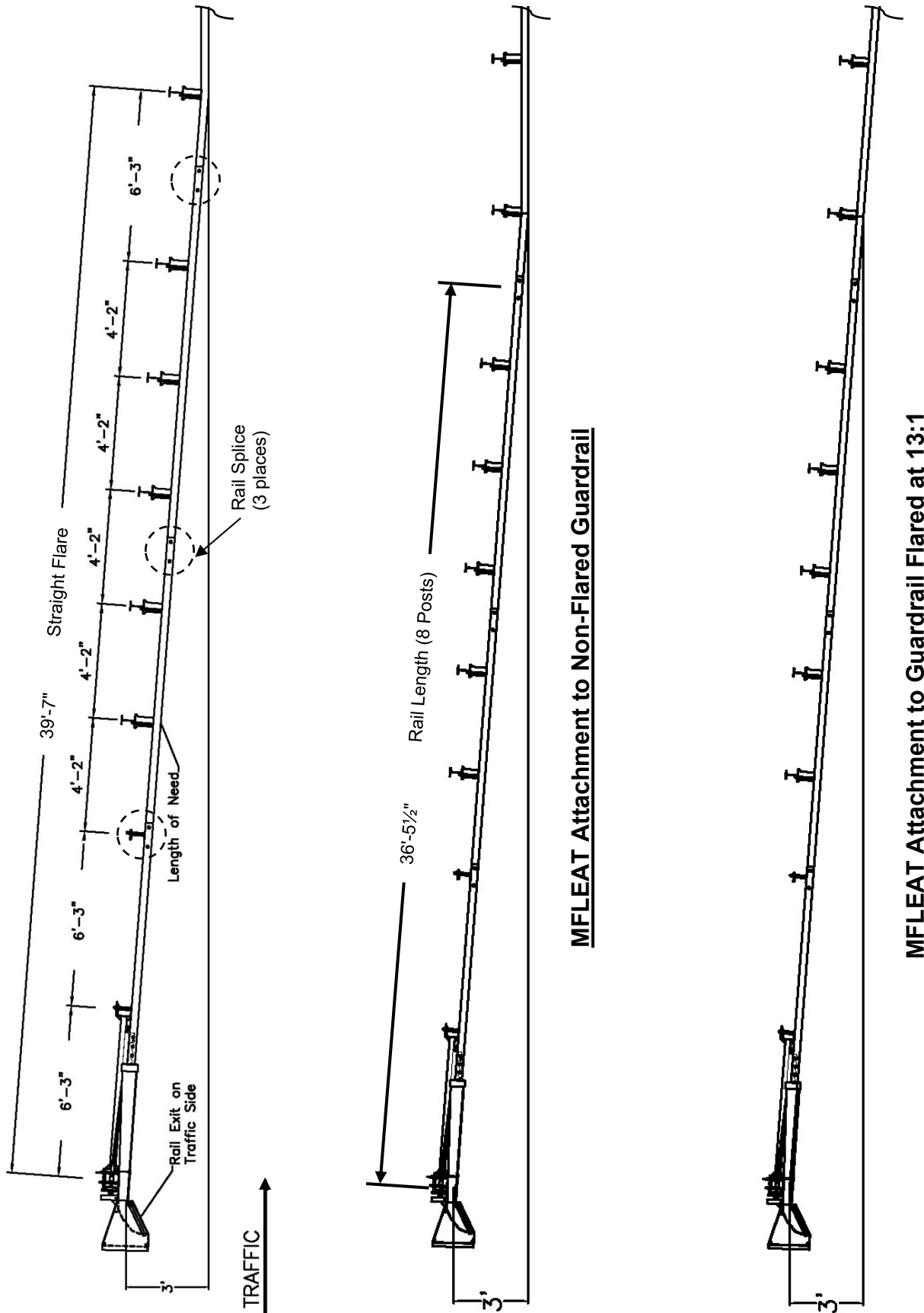

MFLEAT Attachment to Non-Flared Guardrail

MFLEAT Attachment to Guardrail Flared at 13:1

Figure 1.

3.3 MFLEAT Guardrail Panel Configuration

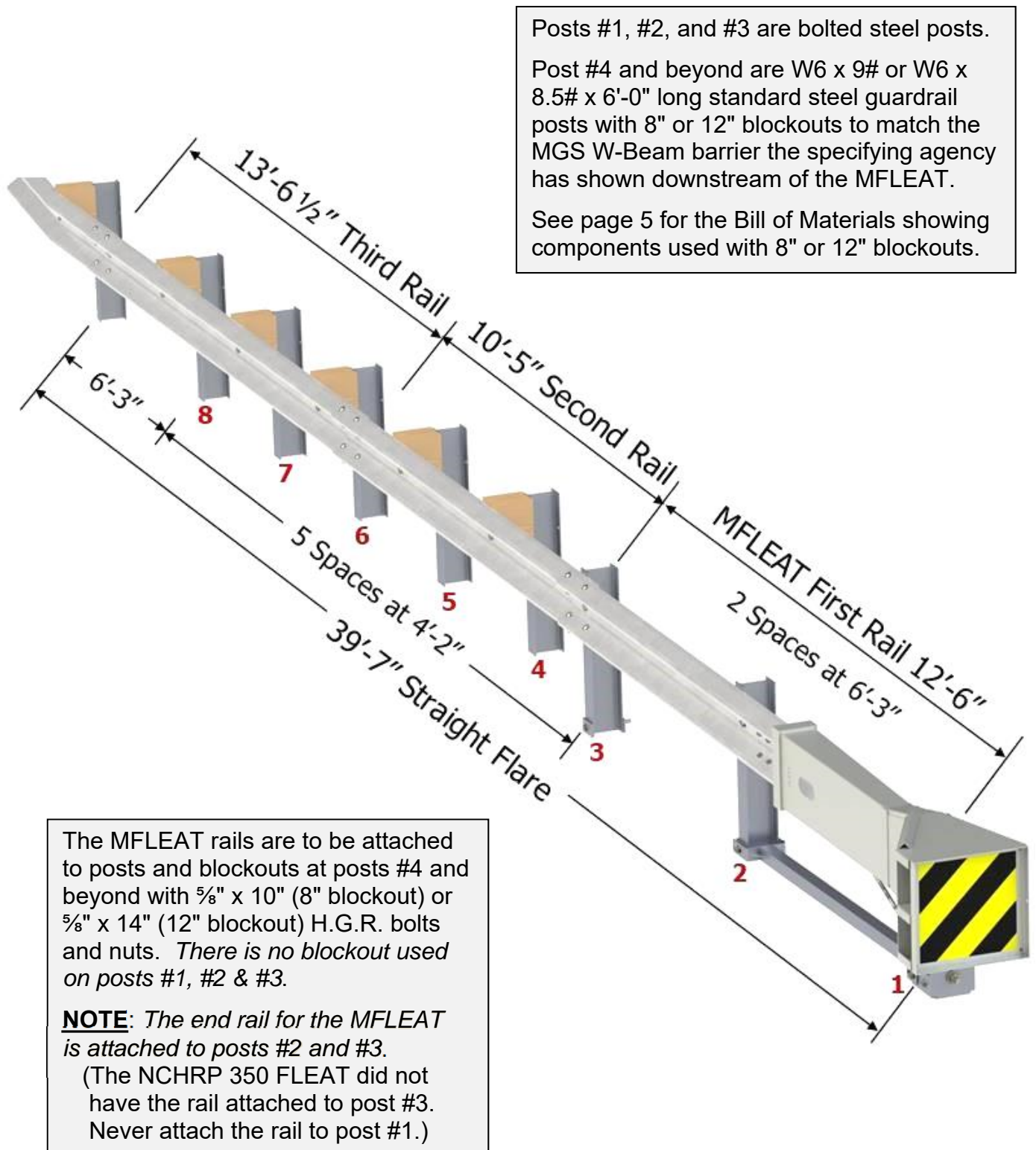
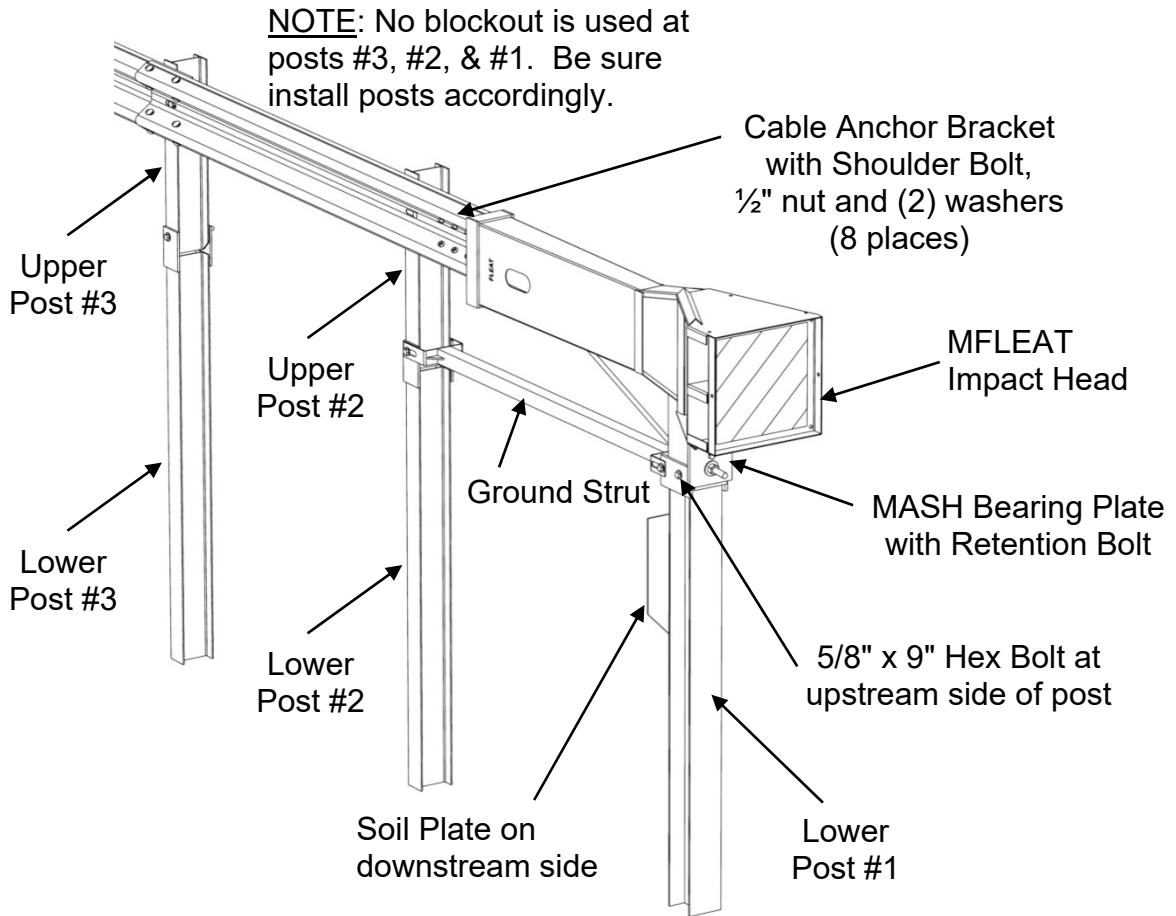

Figure 2.

3.4 View of MFLEAT Steel End Post #1



NOTE: Be sure the 5/8" x 9" hex bolt at Hinged Post #1 is on the upstream side of the post.

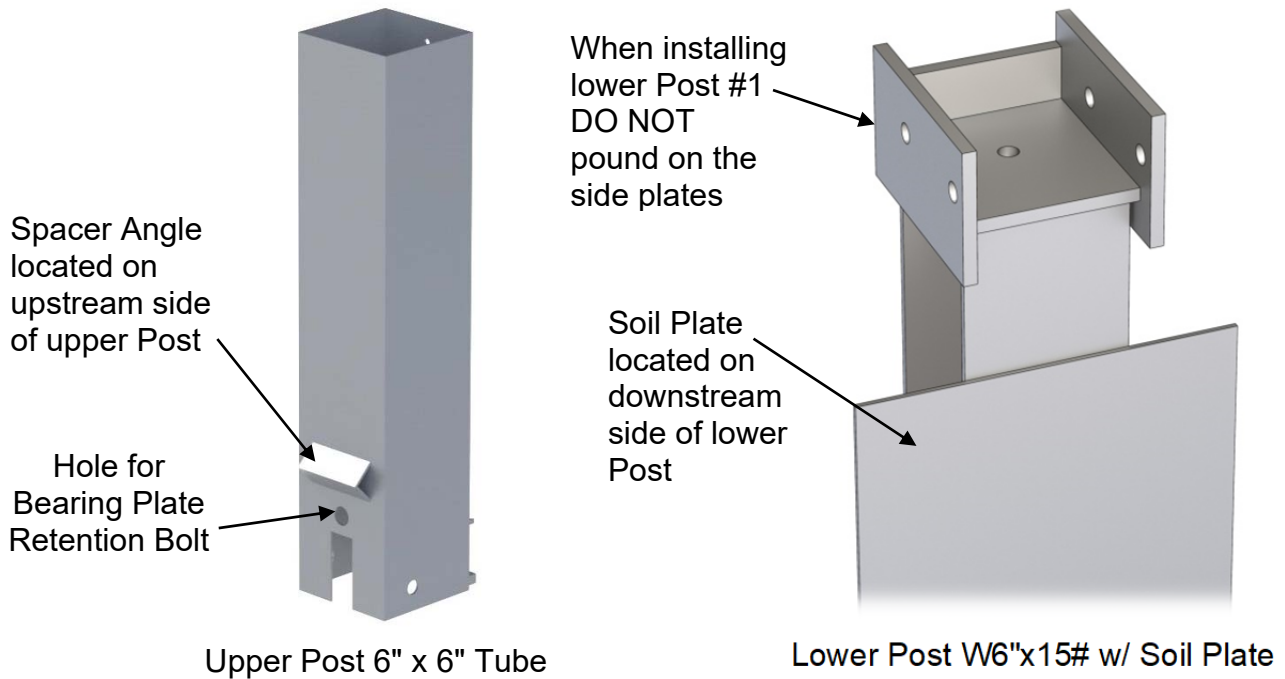
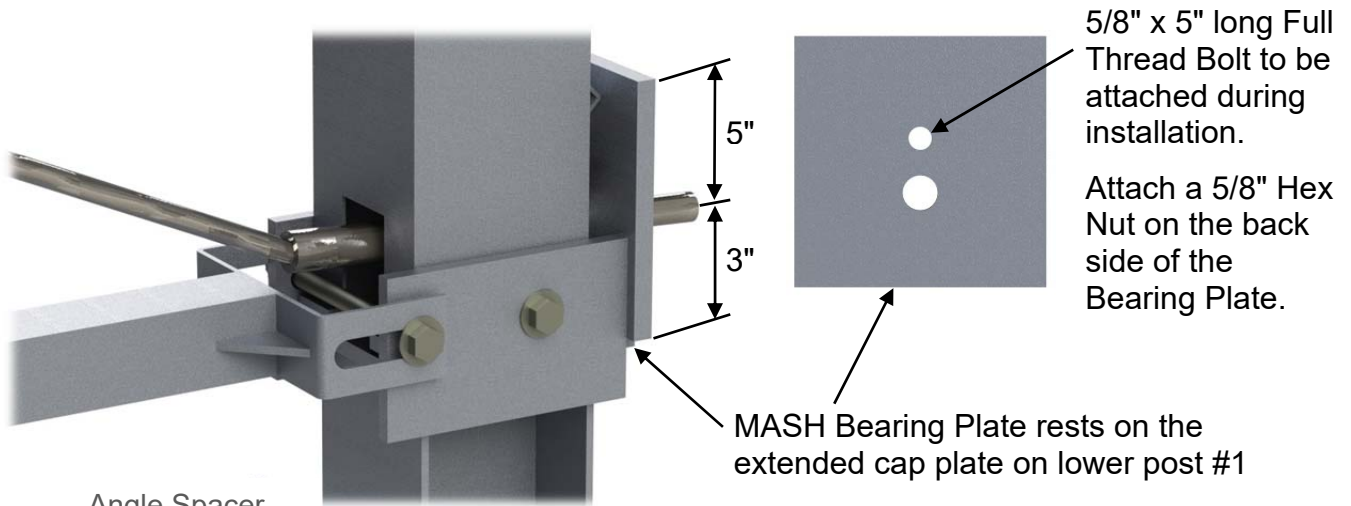
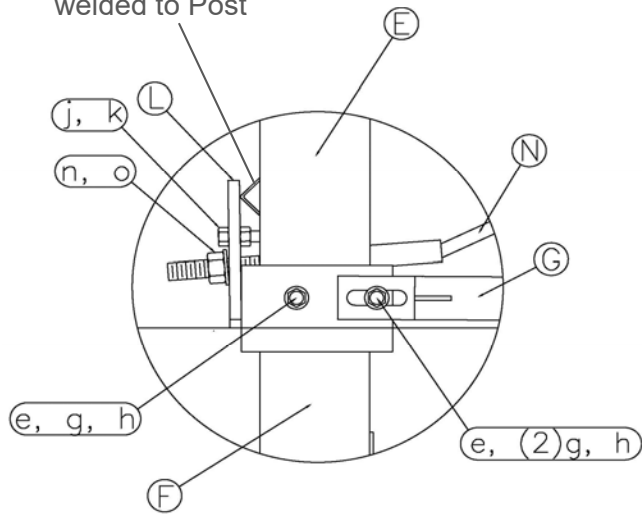

Figure 3.

3.5 Post #1 Connection Detail for MFLEAT



Angle Spacer welded to Post



E	Upper Post #1 Tube 6" x 6"
F	Lower Post #1 W6" w/ Soil Plate
G	Ground Strut
L	MASH Bearing Plate 8" x 8"
N	Cable Anchor Assembly
e	5/8" x 9" Hex Bolt
g	5/8" Washer
h	5/8" H.G.R. Nut
j	5/8" x 5" Full Thread Bolt
k	5/8" Hex Nut
n	1" Nut
o	1" Washer



5/8" x 9" hex bolt, nut, & washer at post #1 on upstream side of the post

5/8" x 9" hex bolt, nut, & two washers through the extended side plates to attach the ground strut to lower post #1

3/4" x 8 1/2" hex bolt, & nut at posts #2 & #3 on downstream side of the post. A 3/4" washer is not needed but may be used.

Figure 4.

3.6 Posts #2 and #3 Connection Detail for MFLEAT

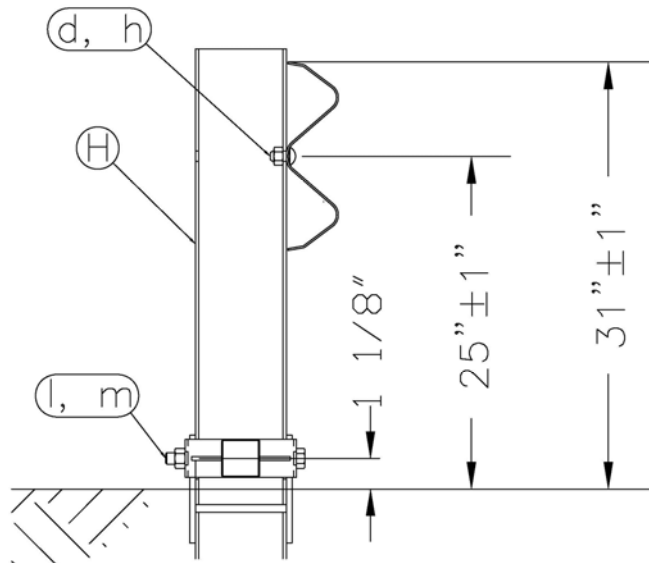
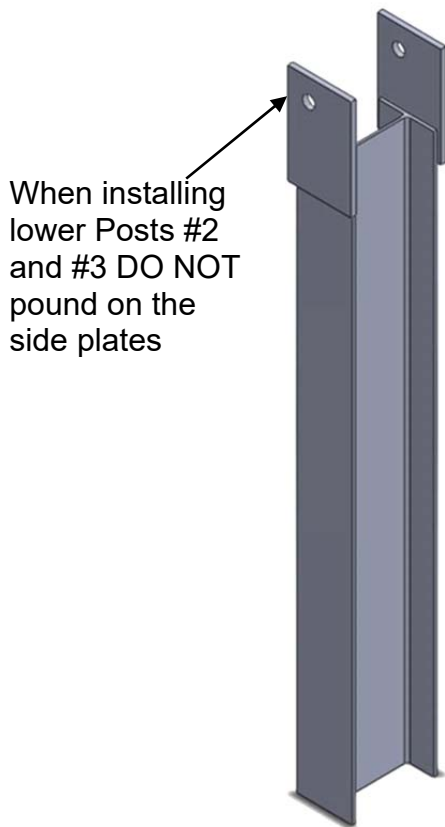

H	Upper Post #2 W6" x 8.5 #
d	5/8" x 1 1/4" Guardrail Splice Bolt
h	5/8" H.G.R. Nut
l	3/4" x 8 1/2" Hex Bolt
m	3/4" Nut

NOTE: Be sure the 3/4" x 8 1/2" hex bolt at Hinged Posts #2 and #3 is on the downstream side of the post (toward post #4).

Figure 5.

3.7 Ground Strut Detail for MFLEAT



5/8" x 9" hex bolt, nut, & washer at post #1 on upstream side of the post

5/8" x 9" hex bolt, nut, & two washers through the extended side plates of lower post #1 to attach the ground strut to lower post #1

Longer tabs on Ground Strut attached to post #2

3/4" x 8 1/2" hex bolt, & nut at post #2 on downstream side of the post. A 3/4" washer is not needed but may be used.

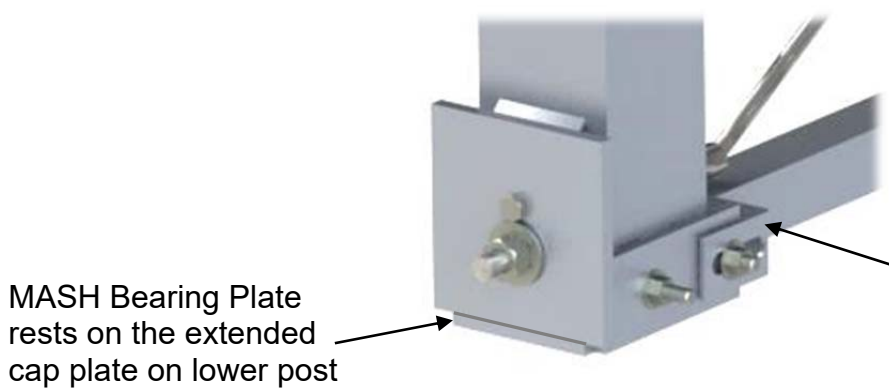

MASH Bearing Plate rests on the extended cap plate on lower post

Shorter tabs on Ground Strut attached to post #1

Figure 6.

3.8 Installation of Cable Anchor (Box) Bracket and Shoulder Bolts

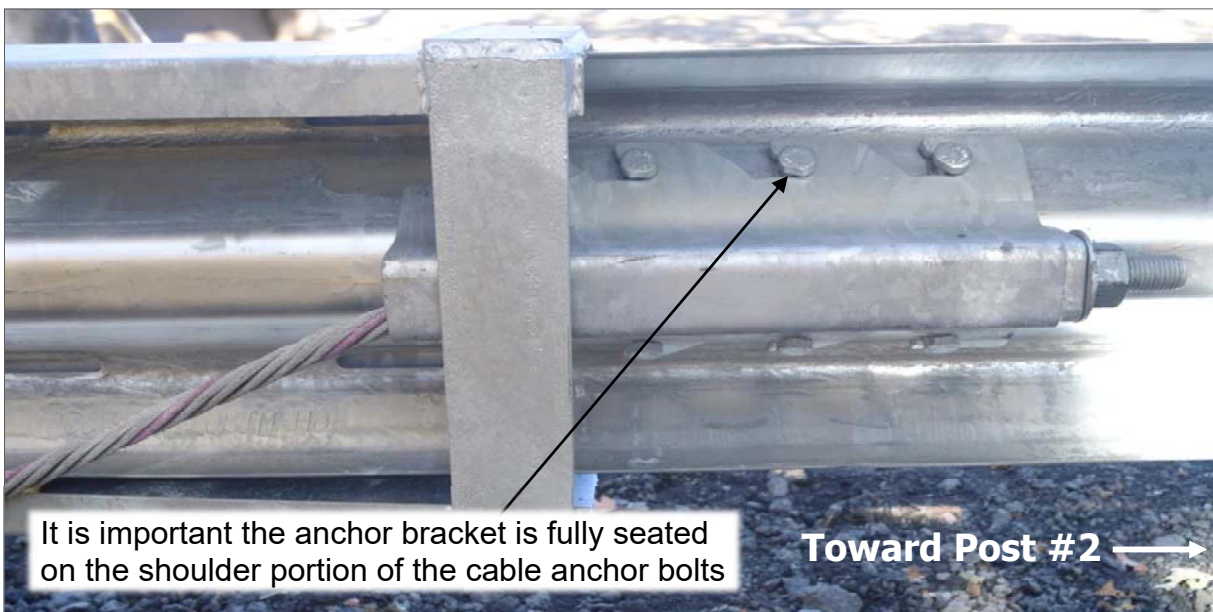
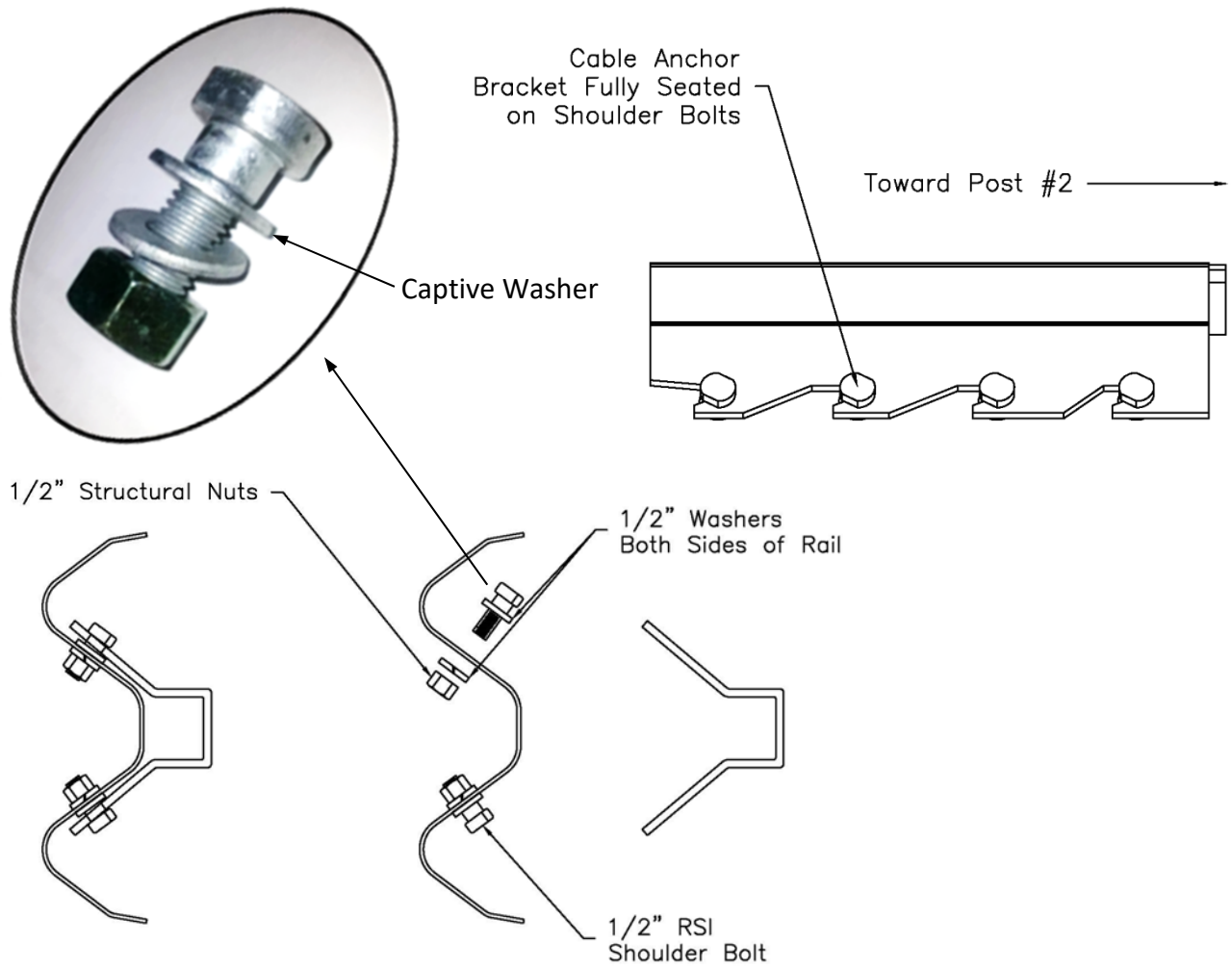

Figure 7.

3.9 Impact Head Connection Detail for MFLEAT

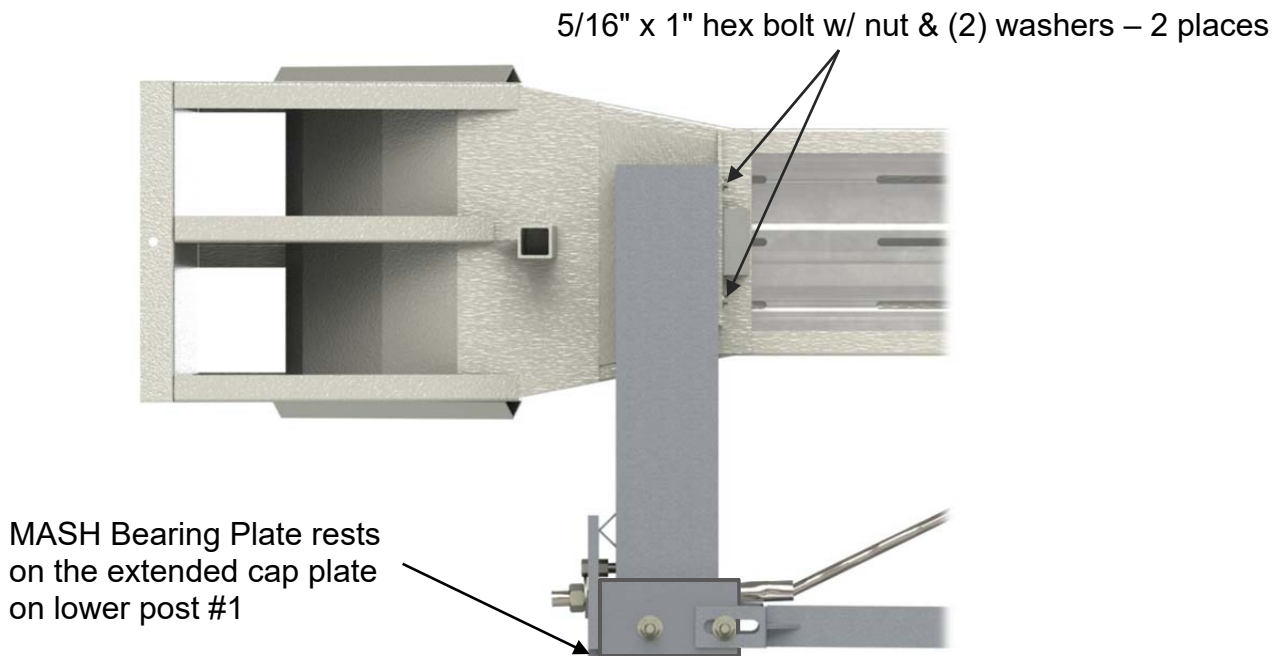
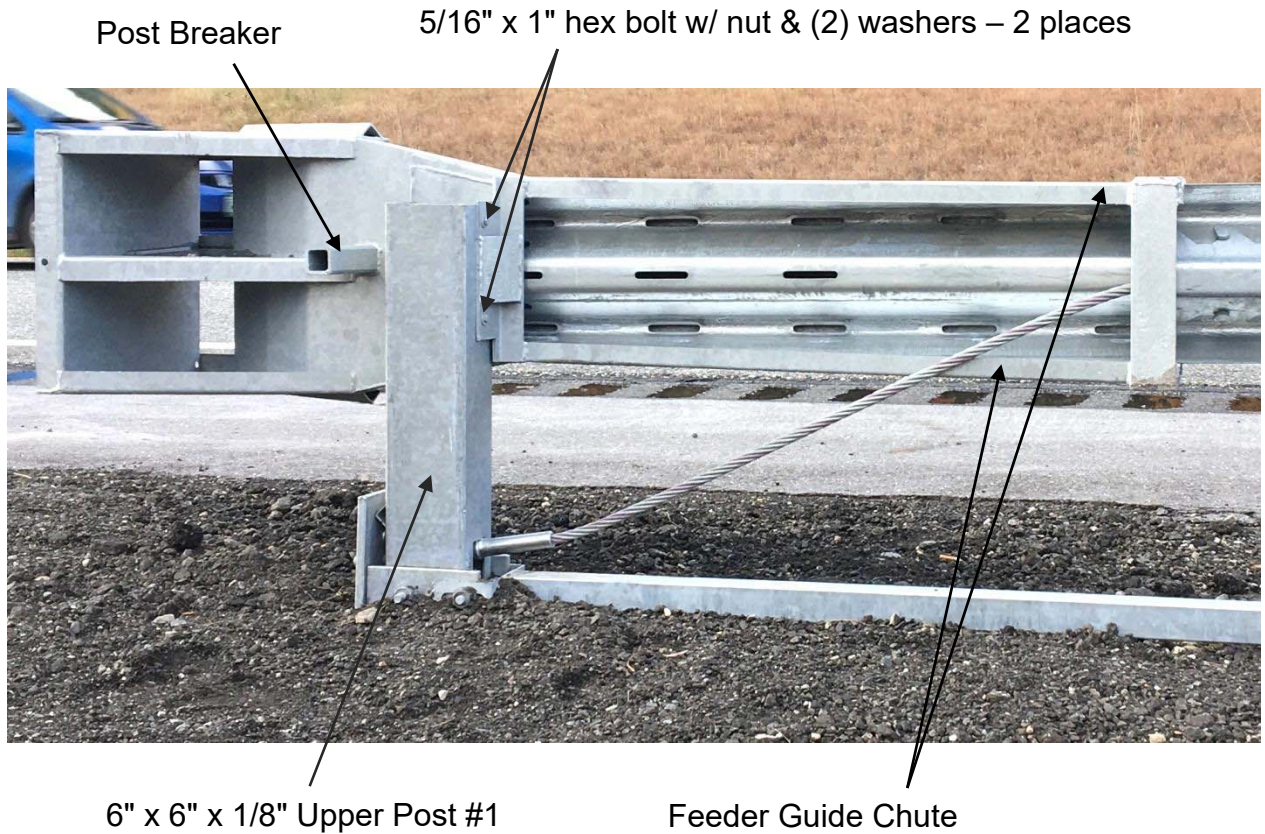
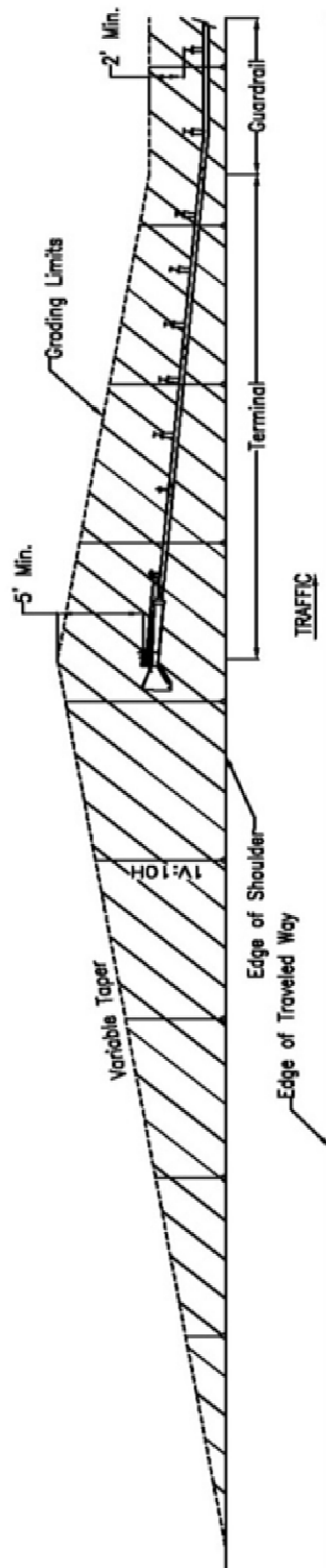

Figure 8.

3.10 Grading Recommendations for MFLEAT



(Reference AASHTO Roadside Design Guide)

Figure 9.

4 Installing the MFLEAT

4.1 Materials

A list of the materials required for the MFLEAT are shown in the **Bill of Materials** section on page 5. Note that either 8" or 12" blockouts may be used with the MFLEAT. The Test Level 3 system has an overall rail length of 36'-5½" and a straight flared length of 39'-7". See **Figure 1**.

4.2 Site Preparation

When the guardrail is installed parallel to the edge of the shoulder, the 3-ft offset of the MFLEAT is measured from a line extending from the guardrail. See **Figure 1**.

Site grading may be necessary to prevent the lower section of the breakaway Steel Posts from extending more than 4" above the ground. Refer to **Figure 9** for the grading recommendations.

4.3 Tools Required

The tools required for installation of the MFLEAT system are the same as those used to install standard highway guardrails, including sockets/wrenches, a hammer, vice grips or pipe wrench, and other equipment such as augers, tampers, & post pounders commonly used in driving guardrail posts. In addition, the installer should provide the *proper driving caps* to be sure they do not pound on side plates of lower posts #1, #2, and #3. The installer should provide driving caps to accommodate the equipment used to install the posts.

4.4 Installation Procedures

Begin the installation at the downstream end of the MFLEAT to ensure that the terminal matches up with the standard downstream section of guardrail. The major steps in the installation of the terminal are as follows:

- Install standard steel guardrail posts #4 and beyond.
- Install bolted steel posts #3, #2, and #1.
- Install ground strut.
- Install the two special length guardrail panels. Post spacing varies.
- Install 12'-6" end panel.
- Install cable anchor bracket and shoulder bolts.
- Install the MFLEAT impact head.
- Install cable assembly and MASH bearing plate.

4.4.1 Installing Standard Steel Guardrail Posts #4 and Beyond

All posts at locations #4 to #8 are W6x9# or W6x8.5# x 6'-0" long standard steel guardrail posts spaced at 4'-2" centers. After post #8 begin the 6'-3" post spacing. Blockouts may be 8" or 12". The finished guardrail height should be approximately 31" ± 1" above the edge of the shoulder or the finished grade.

The Test Level 3 MFLEAT system has an overall rail length of 36'-5½" and a straight flared length of 39'-7". See **Figure 1**.

NOTE: The MGS barrier requires mid-span splices between posts. Pay limits of the terminal are up to the DOT and may vary.

4.4.2 Installing Bolted Steel Posts #1, #2, and 3

Posts #1, #2, and #3 are bolted steel posts. These bolted posts must have the lower section installed before attaching the top section. Be sure an adequate driving cap is used so welds on the cap plate of post #1 and the welds on the side plates of posts #2 and #3 are not damaged. The lower sections of the bolted hinged steel posts should not be driven with the upper post attached. Posts #1, #2, & #3 are spaced at 6'-3" centers and are offset because they do not use a blockout.

Upper and Lower Posts #2 and #3 are W6x9# or W6x8.5# sections. Bolt the upper and lower posts together with a ¾" x 8 ½" hex bolts and nuts. A ¾" washer is not needed but may be used. One end of the ground strut will be placed at post #2. Be sure when the lower segment of the post is installed, the hinge bolt is on the downstream side of the post (opposite the impact head). Upper posts #2 and #3 have an open-ended slot for the post bolt. Be sure the slot is on the upstream side of the post (toward the impact head). See **Figure 5** for post #2 and #3 details.

Upper Post #1 is a 6" x 6" x ⅛" tube section. The post will be placed so the angle spacer is facing oncoming traffic. The MASH bearing plate will rest on this angle spacer. Lower Post #1 is a W6x15# post with a soil plate welded to the post. Bolt upper and lower post #1 together with a ⅝" x 9" hex bolt, nut and washer. Be sure when the post is installed, the ⅝" bolt is on the upstream side of the post (toward the impact head). One end of the ground strut will be placed at post #1 against the extended side plates, not the post itself and will use another ⅝" hex bolt, nut and two washers. Be sure when the lower segment of the post is installed, the soil plate is on the downstream side of the post (opposite the impact head). See **Figure 4**.

The top of the lower post #1, #2, and #3 stubs should not project more than 4" above the ground line when measured along a 5' cord, in compliance with AASHTO specifications. Site grading may be required if the top of the lower post sections project more than 4" above the ground line.

For stiff soils, drill a pilot hole and force the post to the proper depth by impact or vibratory means with an appropriate driving cap. Do not drive or pound on the side plates of lower posts #1, #2, or #3 as they may be damaged.

The posts may also be installed by augering and backfilling if the contractor so prefers. The initial hole must be large enough to allow adequate room for proper compaction of the soil during backfill. *Care must be taken to carefully compact the backfill to prevent settlement or lateral displacement of the post.*

If rock is encountered during driving or excavation, refer to appropriate State specifications for how to proceed or contact Road Systems, Inc. for options on anchor posts #1 and/or #2. These posts may be altered if drilling into solid rock or by providing a concrete footer.

4.4.3 Installing Ground Strut

In the past, some ground struts have attached to posts #1 and #2 utilizing the same bolts that that hold the upper and lower post sections together. For the MFLEAT, that's the condition at post #2 using the $\frac{3}{4}$ " x 8 $\frac{1}{2}$ " hex bolt and nut. However, at post #1 a second $\frac{5}{8}$ " x 9" hex bolt, hex nut, and two washers are placed through the extended side plates on lower post#1, not through the post itself. Note the ground strut is not symmetrical. The end with the longer tabs is attached at post #2 and the end with the shorter tabs is attached at post #1. See **Figure 6**.

4.4.4 Installing the Two Special Length Guardrail Panels

Attach the two special length MGS W-Beam guardrail sections downstream of post #3. Because of the varied post spacing, these panels are 10'-5" and 13'-6 $\frac{1}{2}$ " long. Note these rails are not symmetrical. See **Figure 2** for Guardrail Panel Configurations. These rails are spliced with 8 each $\frac{5}{8}$ " x 1 $\frac{1}{4}$ " H.G.R. (Highway Guard Rail) bolts and $\frac{5}{8}$ " H.G.R. nuts.

4.4.5 Installing 12'-6" End Panel

Attach the MFLEAT W-Beam guardrail end section to span from post 1 to 3 (12'-6" long rail). The Universal End Panel can be identified with eight (8) holes $\frac{3}{4}$ " diameter to attach the cable anchor bracket and thirteen (13) slots. Ten (10) slots $\frac{1}{2}$ " x 4" are in the corrugations of the rail and three (3) slots $\frac{1}{2}$ " x 4" are in the valley of the rail.

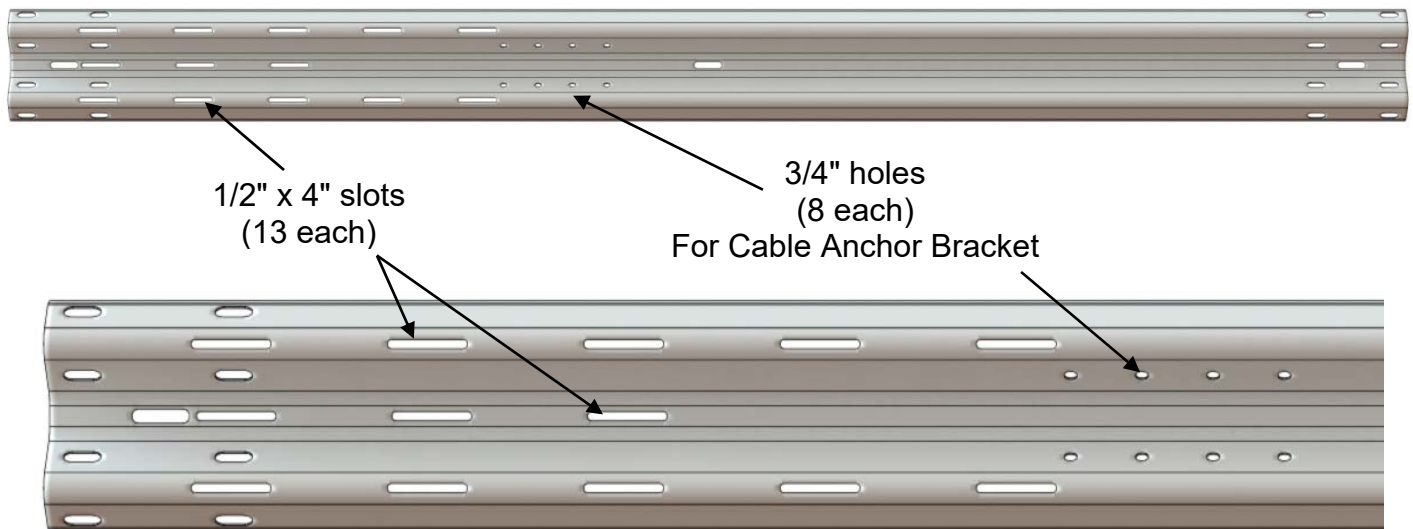

After the two special length MFLEAT rail panels, the downstream W-Beam MGS railing sections shall be the same as those used in MGS highway guardrail with 6'-3" post spacing. All rails are spliced with $\frac{5}{8}$ " x 1 $\frac{1}{4}$ " H.G.R. (Highway Guard Rail) bolts and $\frac{5}{8}$ " H.G.R. nuts.

The MFLEAT rails are to be attached to posts and blockouts at post locations #4 and beyond with $\frac{5}{8}$ " x 10" (8" blockout) or $\frac{5}{8}$ " x 14" (12" blockout) H.G.R. bolts and nuts. ***There are no blockouts used on posts #1, #2 & #3.*** The end rail for the MFLEAT is attached to posts #2 and #3 with a $\frac{5}{8}$ " x 1 $\frac{1}{4}$ " H.G.R. bolt and nut. Never use a longer bolt that passes thru the back flange of posts #2 & #3. **A post bolt is never used at post #1.**

NOTE: All of the W-Beam railing within the MFLEAT terminal must be straight. Radius rail within the terminal is not permitted. Radius rail may begin beyond post #9.

4.4.6 Installing Cable Anchor Bracket

The eight ½" cable anchor bracket shoulder bolts are attached to the W-beam guardrail end section with two ½" structural washers, one on each side of the guardrail, and a ½" structural nut. Be sure the shoulder bolts are placed with the shoulders of the bolts installed on the backside of the guardrail, away from traffic, as shown in **Figure 7**.

For ease of installation, attach the cable anchor bracket shoulder bolts to the rail "finger tight" only. Then align the openings on the cable anchor bracket with the shoulder bolts and tap the cable anchor bracket onto the shoulder portion of the bolts using a hammer. Tighten the bolts with a wrench when the bracket is in place. The welded plate on the cable anchor bracket should be toward Post #2, as shown in **Figure 7**. Be sure the bracket is fully seated on the shoulder portion of the bolts.

4.4.7 Installing MFLEAT Impact Head

The eight cable anchor bracket shoulder bolts & the cable anchor bracket should be attached to the W-beam guardrail end section prior to attaching the MFLEAT impact head to the first post. The MFLEAT impact head will be installed with the rail exit slot on the traffic side.

Place the impact head with the feeder guide chute over the end of the W-beam guardrail. The impact head should be positioned so that the protruding tube (called the post breaker) is on the backside of the guardrail, away from traffic. See below and **Figure 8**. Slide the impact head forward until the post angle attachments on the impact head are aligned with the holes in post #1 (6" x 6" x ⅛" tube). Attach the impact head to upper post #1 with two 5/16" x 1" hex bolts, nut and two washers, one bolt each for the top and bottom post angle attachments.

NOTE: It is recommended that the face of the impact head be delineated with an object marker that meets State specifications for better night visibility. *However, the impact face object marker may not be included as part of the shipped materials for the terminal unless specifically requested in the contract plans or by the customer.*

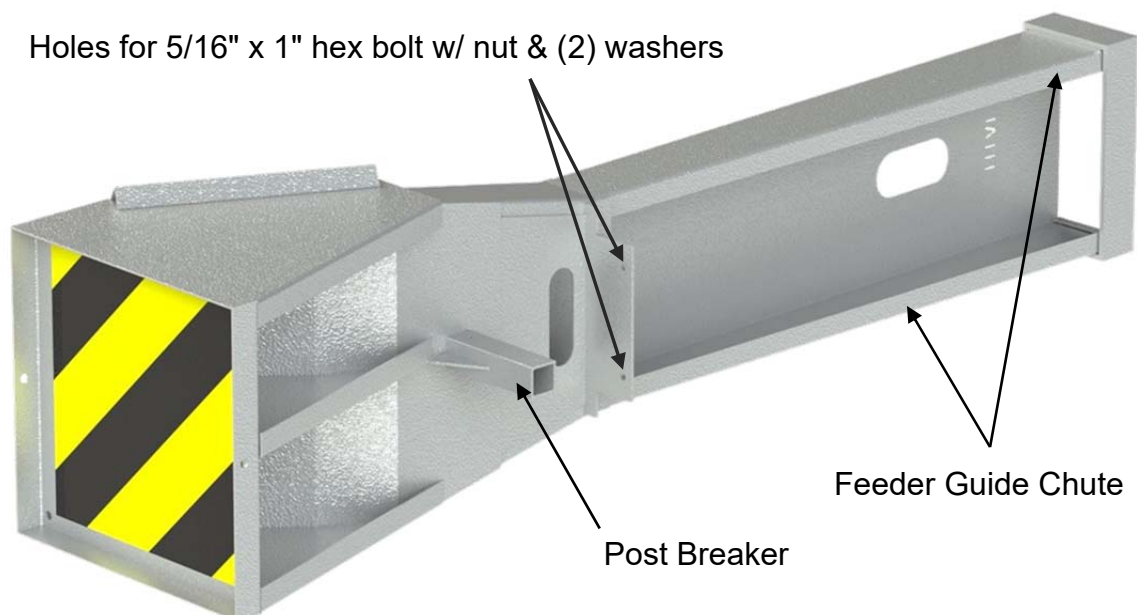

4.4.8 Installing Cable Assembly & MASH Bearing Plate

Place the cable assembly through the cable anchor bracket and through the base of post #1. Note that the cable assembly is fed inside through the feeder chute of the impact head.

Insert the 5/8" x 5" long fully threaded bolt into the smaller hole of the bearing plate. Secure the bolt to the bearing plate with a 5/8" hex nut.

Place the MASH bearing plate at the base of post 1 with the 5" dimension up and 3" dimension down. The bearing plate will rest on the angle spacer welded to upper post #1 and on the cap plate of lower post #1. The threads of the 5/8" x 5" long bolt will set inside the hole of upper post #1. Secure both ends of the cable assembly with a 1" hex nut and washer. While tightening the cable, use a hammer to tap the cable anchor bracket from the downstream end to ensure that it is securely interlocked with the shoulder bolts. Restrain the cable at the end being tightened with vice grips or channel lock pliers to avoid twisting the cable.

Upon completion of the installation, the cable should be taut and the cable anchor bracket should be fully seated on the shoulder portion of the cable anchor bolts.

NOTE: It is very important that the cable anchor bracket be fully seated on the shoulder portion of the cable anchor bolts as shown in **Figure 7**.

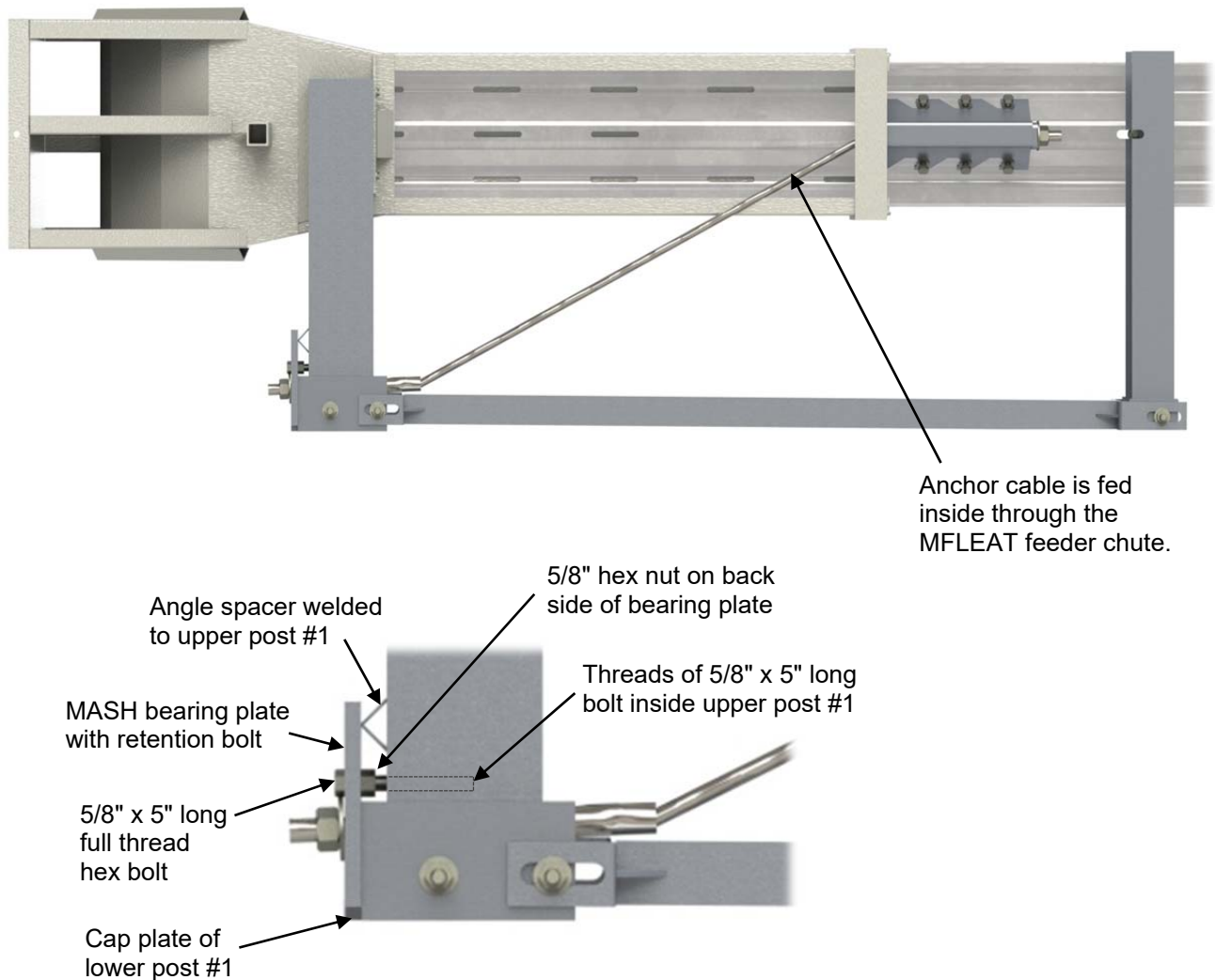

5 MFLEAT Inspection Checklist

State: _____

Date: _____

Project #: _____

Location: _____

- The rail height is in accordance with the contract plans. This should be 31" ± 1" above the edge of the finished grade.
- There is no radiused rail within the MFLEAT 39'-7" length.
- All rails are lapped in the proper direction with traffic.
- The MFLEAT has been placed with a 3'-0" straight flare offset between posts #1 and #9 over the 39'-7" length.
- The end rail panel is not attached to post #1. All other posts are attached to the rail.
- The end rail panel has ½" x 4" slots and is 12'-6" long. The second rail must be 10'-5" long to establish the mid-span splice between posts #5 & #6. The third rail length is 13'-6 ½" long.
- The ¾" x 8 ½" hinge bolt at posts #2 and #3 is on the downstream sides of the posts.
- The ⅝" x 9" bolt connecting upper and lower post #1 is on the upstream side of the post.
- The lower stubs at posts #1, #2, and #3 does not protrude more than 4" above the ground line (measured by the AASHTO 5' cord method). Site grading may be necessary to meet this requirement.
- At posts #2 and #3, the open-ended slot at the post bolts are on the upstream side of the posts.
- Standard steel W6x9# x 6'-0" guardrail posts are used at post locations #4 to #8.
- The post spacing within the MFLEAT (beginning at Post #1) is 2 spaces at 6'-3" centers, 5 spaces at 4'-2" centers, and at Post #8 continuing 6'-3" centers thru the MGS Guardrail.
- The blockouts are 8" or 12" deep depending on State or local agency standards.
- The MFLEAT impact head exit slot is toward traffic.
- Two 5/16" x 1" hex bolts attaching impact head to 6" x 6" x ⅛" upper post #1 are secured.
- The 8" x 8" bearing plate at post #1 is correctly positioned with the 5" dimension up and 3" dimension down and setting on the extended cap plate of lower post #1. The anchor cable is taut and correctly installed.
- A 5/8" x 5" long bolt is secured to the bearing plate and placed in the hole of upper post #1.
- A ground strut is secured between posts #1 & #2 using the ¾" x 8 ½" hinge bolt at post #2 and a second ⅝" x 9" hex bolt at post location #1.
- The cable anchor bracket shoulder bolts are properly attached to the W-Beam guardrail and the cable anchor bracket is fully seated on the shoulder portion of the bolts.
- If the posts were augered, the backfill material around the posts is properly compacted.
- No washers are used on the face of the rail except at the cable anchor bracket bolts.
- The grading and finished installation is in accordance with all specific State DOT guidelines.

Additional notes:

Inspection performed by: _____

Inspection (continued)

As with all roadside safety products, guardrail terminals require inspection to be sure they are in working order. The appropriate authorities should have inspection programs in place and track accidents to assure adequate repairs are made. Regular inspections of MFLEAT systems should be made based on site conditions, traffic volumes, and crash history.

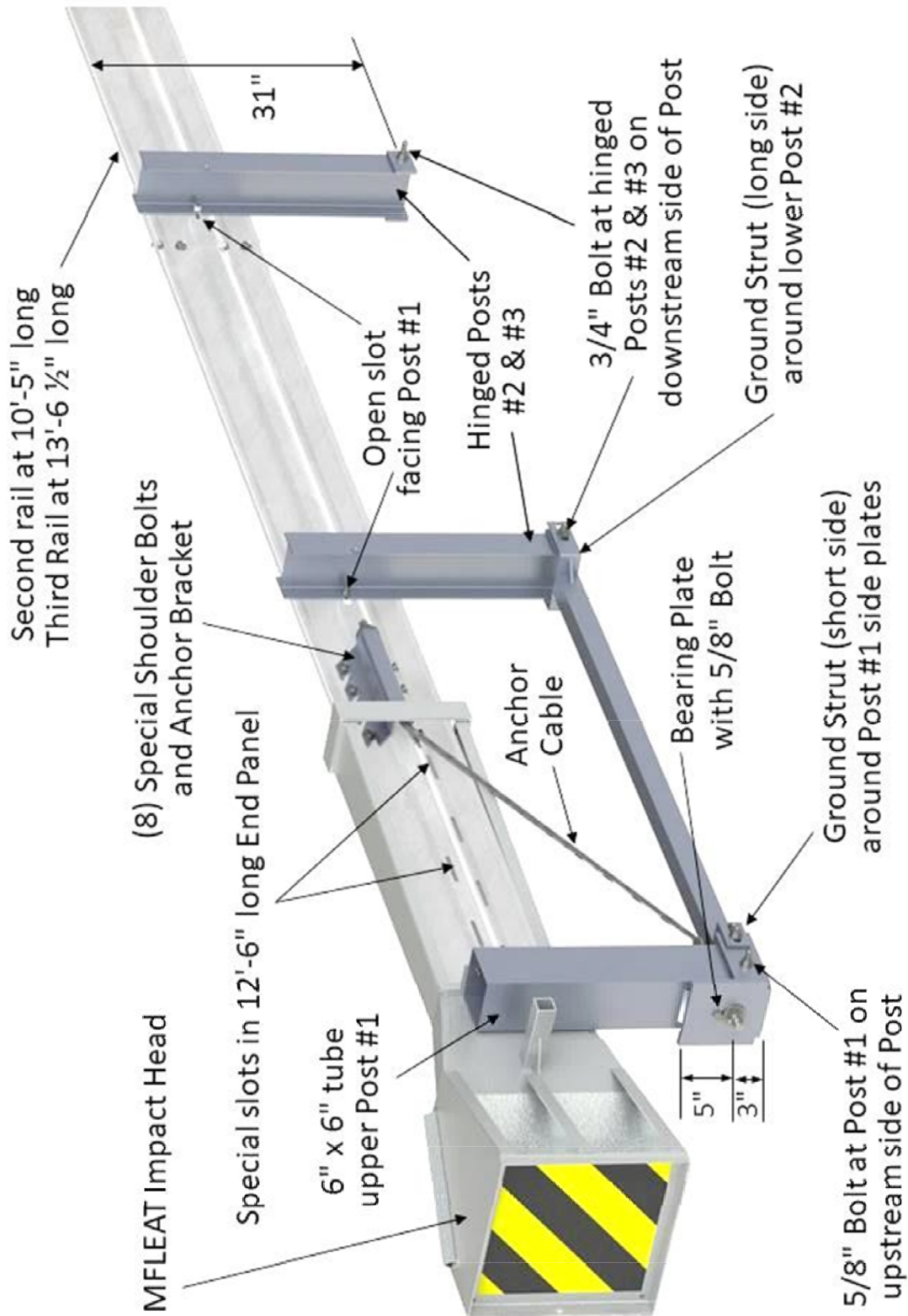

6 Repairing the MFLEAT

Equipment Needed for Repair Operation

- Acetylene torch to metal saw cut or burn off the damaged rail,
- Heavy duty chain to remove the impact head may be required,
- Tools used to install standard highway guardrails, including sockets & wrenches, etc.,
- Vice grip or channel lock pliers,
- Sledge hammer.

Be sure proper traffic control is deployed to protect workers and motorists. Follow the requirements shown in the *Manual on Uniform Traffic Control Devices* (MUTCD).

General Repair Procedures

After an end-on impact occurs with the MFLEAT, it will require replacement of the first 12'-6" end section of rail and any other damaged rail section(s) and any damaged post(s). For a traffic face impact downstream of the impact head, the damage will typically be to the downstream rail section(s) and associated posts.

The general step-by-step procedure for repairing a damaged terminal is as follows:

- (1) Check the impact head for damage.
- (2) Check the cable assembly for damage. The cable anchor bracket, bearing plate, nuts, washers, and the special cable anchor bracket shoulder bolts may be reusable.
- (3) Check the number of broken posts and blockouts that need to be replaced, along with any damaged bolts. Inventory and pick up the reusable parts.
- (4) Torch or cut off the kinked rail at the exit opening near the outlet of the impact head. Because of the open throat configuration, the impact head may be able to be removed by hand at this point. If not, then hook up a chain attachment through the opening behind the impact plate of the impact head. Pull the impact head off the rail with the chain attached to a truck frame with the W-beam guardrail still attached to the downstream guardrail posts.
- (5) Disconnect and remove the damaged rail from the posts.
- (6) Remove the damaged posts. Hinged posts #2 and #3 can be unbolted. Remove the standard steel guardrail posts.
- (7) Reinstall the system following the procedures listed in this manual.

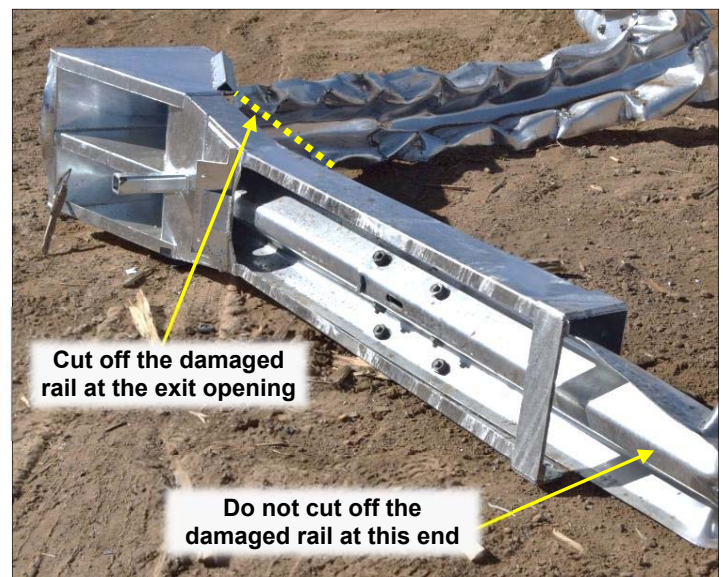

7 Allowable Options for the MFLEAT

The MFLEAT is a Steel Post system using W6 x 9# or W6 x 8.5# x 6-ft long posts at locations 4-8. The FHWA letter allows the MFLEAT to be a Test Level 3 (100 km/hr.) steel post system.

- CC-143 – MFLEAT Test Level 3 (04/10/19)

The MFLEAT may be powder coated over the galvanized surface.

A wood post version of the MFLEAT is not available.

For Test Level 2 (70 km/hr.) applications, the system layout does not change.



