

MAX-TENSION® TL-2 | TANGENT, REDIRECTIVE NON-GATING, GUARDRAIL TERMINAL
WITH SABERTOOTH® TECHNOLOGY

- LIGHTWEIGHT, LOW PROFILE IMPACT HEAD
- AVAILABLE AS A KIT OR SYSTEM
- MASH TL-2 COMPLIANT
- REDIRECTIVE, NON-GATING AT POST 1



Download on the
App Store

GET IT ON
Google Play

The Lindsay Guide
App is available as a
free download from
the Apple Store® and
Google Play™.



REVISIONS

DATE	ECN	PUBLISHED ECN	REVISION	DESCRIPTION OF CHANGE
01/05/2018	3691	3691	A	New release

Important For Your Safety

We have provided important safety messages in this manual. **ALWAYS** read and obey all safety messages.

This is the safety alert symbol.



This symbol alerts you to hazards that can kill or hurt you and others. All safety messages will be preceded by the safety alert symbol and the word “DANGER”, “WARNING”, or “CAUTION”.

These words mean:

 **DANGER** IMMEDIATE HAZARDS THAT WILL RESULT IN SEVERE PERSONAL INJURY OR DEATH.

 **WARNING** Hazards or unsafe practices that COULD result in severe personal injury or death.

 **CAUTION** Hazards or unsafe practices that COULD result in minor personal injury or product or property damage.

This manual must be available to the person(s) overseeing and/or assembling the guardrail terminal system at all times. For additional copies, or if you have any questions about any portion of this manual, see below to contact Lindsay Transportation Solutions.

Contact Information

Lindsay Transportation Solutions

U.S. Toll Free: (888) 800-3691

or

+1 (707) 374-6800

www.lindsaytransportationsolutions.com

STANDARD LIMITED WARRANTY

Lindsay Transportation Solutions, Inc. (collectively with its parent company Lindsay Corporation and all other subsidiaries and affiliates directly and indirectly owned by Lindsay Corporation, "LTS") has tested the impact performance of certain of its barriers, crash cushion systems, and other highway safety hardware at an ISO-certified crash testing laboratory under controlled conditions pursuant to the test matrix criteria of NCHRP 350, MASH or EN-1317, as applicable, as designated by the American Association of State Highway and Transportation Officials ("AASHTO") and the Federal Highway Administration ("FHWA"), or the European Committee for Standardization ("CEN"). Such tests do not replicate every possible crash scenario and they are not intended to represent the performance of barriers, crash cushion systems, and other highway safety hardware when impacted in every real world impact condition or by every vehicle type. It is widely recognized that there are impact conditions that exceed the performance expectations of all highway safety equipment.

The products with which this limited warranty is provided (the "Products") are intended to be installed, operated, and maintained in a manner not inconsistent with instructional materials provided by LTS, the AASHTO Roadside Design Guide (as applicable), and state and federal guidelines (as applicable). Selection and proper installation, operation, and maintenance of any highway safety product, including the Products, is the responsibility of the highway authority and state department of transportation.

LTS EXPRESSLY DISCLAIMS ANY WARRANTY OR LIABILITY FOR CLAIMS ARISING BY REASONS OF DEATH OR PERSONAL INJURY OR DAMAGE TO PROPERTY RESULTING FROM ANY IMPACT, COLLISION OR HARMFUL CONTACT WITH THE PRODUCTS OR NEARBY HAZARDS OR OBJECTS BY ANY VEHICLE, OBJECTS, OR PERSONS, REGARDLESS OF WHETHER THE PRODUCTS WERE INSTALLED IN CONSULTATION WITH LTS OR BY THIRD PARTIES.

LTS warrants that any Product or component part manufactured by LTS will be free from defects in material or workmanship. LTS will replace free of cost any Product or component part manufactured by LTS that contains such a defect.

THE FOREGOING WARRANTY IS IN LIEU OF AND EXCLUDES ALL OTHER WARRANTIES NOT EXPRESSLY SET FORTH HEREIN, WHETHER EXPRESS OR IMPLIED BY OPERATION OF LAW OR OTHERWISE, INCLUDING BUT NOT LIMITED TO ANY IMPLIED WARRANTIES OF MERCHANTABILITY OR FITNESS FOR A PARTICULAR PURPOSE.

LTS, in its sole discretion, may elect to disclaim the foregoing warranty benefits with respect to (i) any Products that have been inspected and determined by LTS, in its sole discretion, (a) to have been subject to improper storage, accident, misuse, or unauthorized alterations, or (b) that have not been installed, operated, and maintained in accordance with approved procedures and guidelines (including but not limited to instructions included in materials provided by LTS and the AASHTO Roadside Design Guide) and (ii) any components manufactured by the Buyer.

LTS' LIABILITY UNDER THIS WARRANTY IS EXPRESSLY LIMITED TO REPLACEMENT FREE OF COST (IN THE FORM AND UNDER THE TERMS ORIGINALLY SHIPPED), OR TO REPAIR BY LTS, OF PRODUCTS OR PARTS NOT COMPLYING WITH LTS SPECIFICATIONS, OR, AT LTS' ELECTION, TO THE REPAYMENT OF AN AMOUNT EQUAL TO THE PURCHASE PRICE OF SUCH PRODUCTS OR PARTS, WHETHER SUCH CLAIMS ARE FOR BREACH OF WARRANTY OR NEGLIGENCE. LTS SHALL NOT BE LIABLE FOR ANY INCIDENTAL, CONSEQUENTIAL, OR SPECIAL LOSSES, DAMAGES, OR EXPENSES OF ANY KIND, INCLUDING, WITHOUT LIMITATION, ANY SUCH LOSSES, DAMAGES, OR EXPENSES ARISING DIRECTLY OR INDIRECTLY FROM THE SALE, HANDLING, OR USE OF THE PRODUCTS FROM ANY OTHER CAUSE RELATING THERETO, OR FROM PERSONAL INJURY OR LOSS OF PROFIT.

Any claim by the Buyer with reference to Products sold hereunder for any cause shall be deemed waived by the Buyer unless LTS is notified in writing, in the case of defects apparent on visual inspection, within ninety (90) days from the delivery date, or, in the case of defects not apparent on visual inspection, within twelve (12) months from the said delivery date. Products claimed to be defective may be returned prepaid to LTS' plant for inspection in accordance with return shipping instructions that LTS shall furnish to the Buyer forthwith upon receipt of the Buyer's notice of claim. If the claim is established, LTS will reimburse that Buyer for all carriage costs incurred hereunder.

W030587 Rev. 11 revised October 16, 2017



Table of Contents

Important For Your Safety	3
Contact Information	3
Standard Limited Warranty	4
MAX-Tension® TL-2 System Overview	6
Recommended Tools	7
Safety Equipment	7
Traffic Control	7
Preparation	8
Documentation	8
Soil Conditions.....	9
Important Notes.....	9
Site Grading	10
System Offset Requirements	11
Curve Installations	11
Panel Lapping	11
Parts Identification	12
Bill of Materials.....	15
Step 1 - Post Assembly and Installation	16
Step 2 - Ground Strut and Soil Anchor Installation	17
Step 3 - Blockout Installation	18
Step 4 - Assemble Inner Side Slider (ISS) Panel on Rail 2.....	19
Step 5 - Install Rail 2	20
Step 6 - Assemble Traffic Side Slider (TSS) and Tooth on Rail 1	21
Step 7 - Install Rail 1	22
Step 8 - Install Impact Head	23
Step 9 - Install Cables.....	24
Step 10 - Turn Friction Plate.....	25
Step 11 - Tighten Cables	26
Step 12 - Install Rear Side Slider (RSS) Plate and Tighten Tooth.....	27
Step 13 - Install Delineation Bracket.....	28
Inspector Checklist.....	29
Maintenance Inspection.....	30
Drawings.....	33
Long Term Storage.....	41
Notes.....	42

MAX-Tension® TL-2 System Overview



The MAX-Tension® TL-2 Guardrail Terminal System (MAX TL-2) is a re-directive, non-gating tension-based end terminal for corrugated W-Beam barrier systems in tangent configurations. The MAX TL-2 system has been tested and evaluated per the recommendations set forth in the *Manual for Assessing Safety Hardware (MASH) Test Level 2 tests at 70 km/h (43.5 mph)*. The system utilizes tensioned cables and a cutting tooth to absorb kinetic energy and safely contain or redirect an impacting vehicle.

The system is comprised of a friction-based energy-absorbing impact head, two tensioned cables, a releasable Post 1, a ground anchor assembly and an energy-absorbing coupler with integrated cutting tooth used in conjunction with standard AASHTO 12-gauge guardrail panels, post, blockouts, and hardware.

The MAX TL-2 is applied directly to W-Beam guardrail systems at, or transitioned to 31 in. (787mm) with panels and post spacing configured at mid-span splice. Transitions to strong post W-Beam guardrail systems or other barriers where the splice is not mid-span can be accomplished using 3 Ft. 1-1/2 In. (0.95m), 9 Ft. 4-1/2 In. (2.85m), or 15 Ft. 7-1/2 In. (4.75m) panels after the MAX TL-2 system [minimum of 25 Ft. (7.62m) downstream of the first post] in accordance with Federal, State, and Local standards. Transitions to other barrier systems such as three beam or rigid bridge or roadside barriers shall be in accordance with Federal, State, and Local requirements and attached after the MAX TL-2 system [minimum of 25 Ft. (7.62m) downstream of the first post].

Recommended Tools

NOTE: The list of tools, safety equipment, and traffic control is a general recommendation and should not be considered a comprehensive list. Depending on the specific characteristics of the job site and the complexity of the repair or assembly, more or less tools may be necessary.

- Post Driver/Auger
- Soil Tamper
- Tape Measure
- String Line
- Chalk Line
- Marking Paint
- Level
- Hammer
- Crescent/Spud Wrench
- Pry Bar (recommended minimum 6' length)
- Vice Grips or Clamps
- 1-5/8" (42mm) Wrench
- 1/2" Ratchet
- 1-1/4" Socket
- 15/16" Socket
- 1-1/8" Socket
- 7/16" Socket
- Pipe Wrench or Large Pliers
- Impact Wrench (Optional)

Safety Equipment

- Safety Glasses
- Hearing Protection
- Gloves
- Steel Toe Boots
- Hard Hat
- Safety Vest

Traffic Control

- Traffic Control Equipment
- Traffic Control Plan

Preparation

The MAX-Tension® TL-2 Guardrail Terminal System (MAX TL-2) is a re-directive, non-gating tensioned-based end terminal for corrugated W-Beam barrier systems in tangent configurations. The MAX TL-2 is applied directly to W-Beam guardrail systems at, or transitioned to, 31 in. [787mm] with panels and post spacing configured at mid-span splice. Transitions to strong post W-Beam guardrail systems or other barriers where the splice is not mid-span can be accomplished using 3ft. 1-1/2in. [0.95m], 9ft. 4-1/2in. [2.85m], or 15ft. 7-1/2in. [4.75m] panels after the MAX TL-2 system (minimum of 25 Ft. (7.62m) downstream of the first post) in accordance with Federal, State, and Local standards. Transitions to other barrier systems such as thrie beam or rigid bridge or roadside barriers shall be in accordance with Federal, State, and Local requirements and attached after the MAX TL-2 system (minimum of 25 Ft. (7.62m) downstream of the first post).

Before installing the MAX TL-2 system, ensure that all the materials required for the system are on site and have been identified.

Documentation

Prior to installation and assembly of the MAX-Tension® TL-2 system, ensure you have read and understand the installation and assembly instructions. The following items should be reviewed and understood prior to installation.

- Installation and Assembly Manual (Check for current revision posted at <http://www.barriersystemsinc.com/>)
- System Drawing (Current Revision)
- Installation and Assembly Video, Mobile App - The Lindsay Guide App is available as a free download from the Apple Store® and Google Play™
- Installation and Assembly Video, Online - Full Installation videos can be viewed online at <http://lindsay.guide>

Soil Conditions

The MAX-Tension® TL-2 system has been designed to be installed in soil that meets or exceeds the AASHTO “standard soil” specification. If the specific site soil conditions differ from those specified in the AASHTO standard soil specification, the installation should be reviewed and approved by the Project Engineer. If rock or stiff soil is encountered, the posts and soil anchor may be installed by auguring and backfilling the hole. Extra care must be taken to prevent settlement and lateral displacement of the posts. Backfill material should be compacted to optimum compaction using a tamper, per Local requirements.

Important Notes

- Ensure the MAX-Tension® TL-2 system is properly transitioned in accordance with Federal, State, and Local standards when attaching any other type of barrier system other than corrugated W-Beam.
- Do not attach the MAX-Tension® TL-2 system directly to a rigid barrier (e.g. concrete barrier, steel barrier, concrete structure) without proper transition.
- The term Upstream = Towards the impact head.
- The term Downstream = Away from impact head.

Site Grading

All testing was completed on a relatively flat and controlled testing environment. Ensure proper site grading prior to installation of the MAX-Tension® TL-2 system in accordance with Federal, State and Local specifications, in addition to the AASHTO Roadside Design Guide.

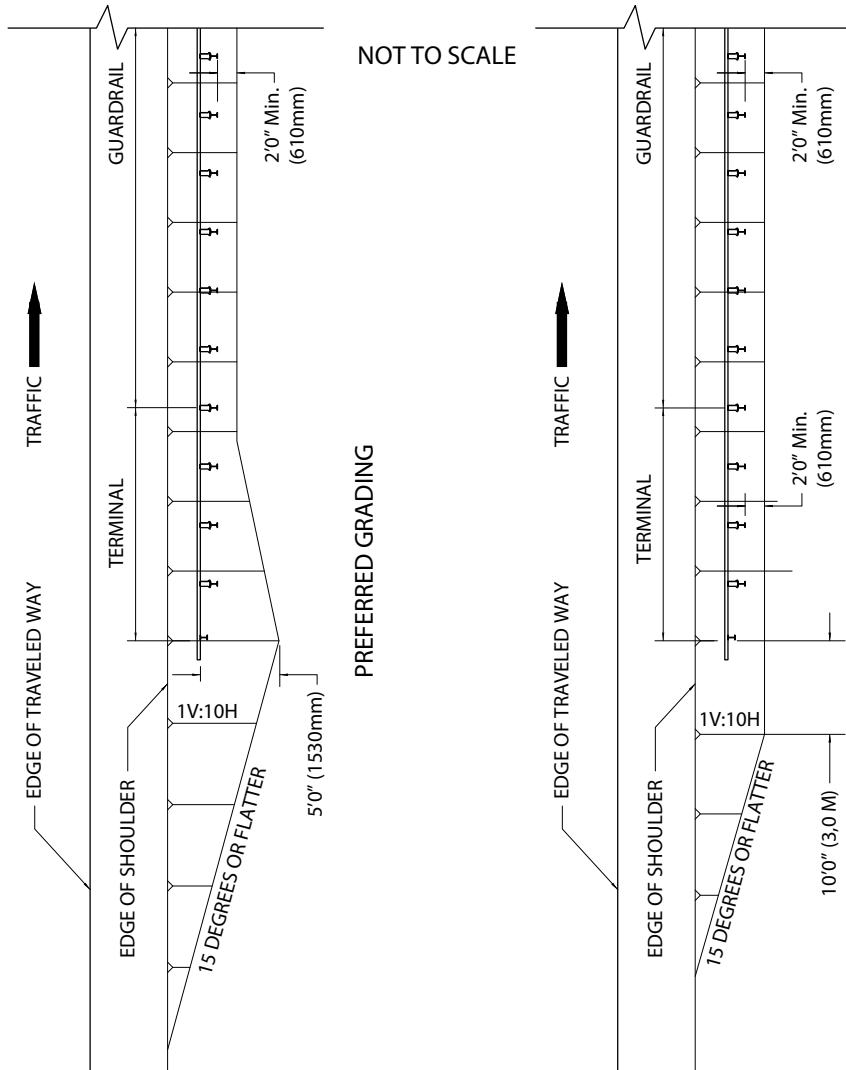

Source: AASHTO Roadside Design Guide, 4th Edition 2011, page 8-6

System Offset Requirements

The MAX-Tension® TL-2 system is a tangent terminal that shall be installed parallel to the edge of the roadway. The system may be installed offset away from the roadway if specified and approved by the Project Engineer. If offset, the system shall be offset over the entire length of the system from the center of the last splice to the Soil Anchor.

Approved Offset

Test Level 2
0-2ft. (610mm)

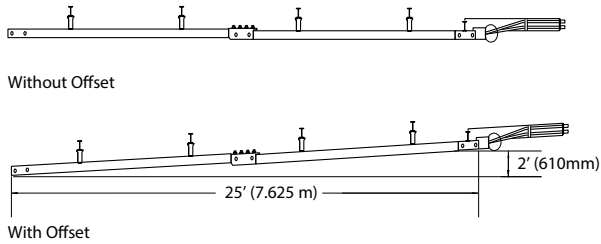

Curve Installations

The MAX-Tension® TL-2 system **SHALL NEVER** be installed within a curved section of guardrail. It is recommended that the guardrail be extended past the curve before the installation of the MAX-Tension® TL-2 system. The MAX-Tension® TL-2 system should always be installed in a straight line over the length of the system.

Panel Lapping

The MAX-Tension® TL-2 system is a tension-based system that slides backwards upon impact. For the panels to slide properly, panel 1 must lap over panel 2, panel 2 must lap over the existing rail system. This applies to both approach end and trailing end terminals, no matter the direction of traffic. Failure to follow this lapping pattern can result in serious injury or death.

Parts Identification

⚠ WARNING Use only Lindsay Transportation Solutions parts that are specified by Lindsay Transportation Solutions for use with the MAX-Tension® TL-2 Guardrail Terminal System. Do not use or co-mingle parts from other systems, as such configurations have not been tested nor have they been approved for use. The use of unspecified parts is prohibited and could result in severe personal injury or death.

<p>1</p> 	<p>2</p> 	<p>3</p> 
<p>Soil Anchor BSI-1610060-00, Qty. 1</p>	<p>Ground Strut BSI-1610061-00, Qty. 1</p>	<p>Impact Head BSI-1610062-00, Qty. 1</p>
<p>4</p> 	<p>5</p> 	<p>6</p> 
<p>I-Beam Post (Post 1) BSI-1610063-00, Qty. 1</p>	<p>Traffic Side Slider Panel BSI-1610064-00, Qty. 1</p>	<p>Inner Side Slider Panel BSI-1610065-00, Qty. 1</p>
<p>7</p> 	<p>8</p> 	<p>9</p> 
<p>Tooth BSI-1610066-00, Qty. 1</p>	<p>Rear Side Slider Plate BSI-1610067-00, Qty. 1</p>	<p>Friction Plate B061058, Qty. 1</p>

Highlighted in Grey above denotes shipped with Kit

Parts Identification (Cont.)

<p>10</p>  <p>TL-2 Cable Assembly BSI-1612013-00, Qty. 2</p>	<p>11</p>  <p>Line Post BSI-1012078-00, Qty. 4</p>	<p>12</p>  <p>Blockout B090534, Qty. 4</p>
<p>13</p>  <p>MASH W-Beam Guardrail BSI-4004386, Qty. 2</p>	<p>14</p>  <p>Square Washer BSI-1102027-00, Qty. 1</p>	<p>15</p>  <p>Bolt - $\frac{5}{8}$" x 7" BSI-2001886, Qty. 1</p>
<p>16</p>  <p>Bolt - $\frac{3}{4}$" x 3" BSI-2001885, Qty. 4</p>	<p>17</p>  <p>Guardrail Bolt - $\frac{5}{8}$" x 1-$\frac{1}{4}$" 4001115, Qty. 32</p>	<p>18</p>  <p>Guardrail Bolt - $\frac{5}{8}$" x 10" 2001840, Qty. 4</p>

Highlighted in Grey above denotes shipped with Kit

Parts Identification (Cont.)

<p>19</p>  <p>Washer - $\frac{5}{8}$" 2001636, Qty. 2</p>	<p>20</p>  <p>Guardrail Nut - $\frac{5}{8}$" 4001116, Qty. 39 Kit Qty.3</p>	<p>21</p>  <p>Bolt - $\frac{5}{8}$" x 2" BSI-2001888, Qty. 1</p>
<p>22</p>  <p>Delineation Bracket BSI-1701063-00, Qty. 1</p>	<p>23</p>  <p>Screw - $\frac{1}{4}$" x $\frac{3}{4}$" BSI-2001887, Qty. 6</p>	<p>24</p>  <p>Guardrail Washer, Rect. 4002051, Qty. 1</p>

Highlighted in Grey above denotes shipped with Kit

Bill of Materials

Item #	Part #	Description	Full System	Kit Only
1	BSI-1610060-00	Soil Anchor	1	1
2	BSI-1610061-00	Ground Strut	1	1
3	BSI-1610062-00	Impact Head	1	1
4	BSI-1610063-00	Post, I-BEAM, W 6 x 9, 6ft. (Post 1)	1	1
5	BSI-1610064-00	Traffic Side Slider (TSS) Panel	1	1
6	BSI-1610065-00	Inner Side Slider (ISS) Panel	1	1
7	BSI-1610066-00	Tooth	1	1
8	BSI-1610067-00	Rear Side Slider (RSS) Plate	1	1
9	B061058	BSI, Cable Friction Plate	1	1
10	BSI-1612013-00	TL-2 Cable Assembly (Includes Sleeve, Nuts & Washers)	2	2
11	BSI-1012078-00	Line Post	4	-
12	B090534	W-Beam Composite Blockout 8in	4	-
13	BSI-4004386	12' 6" MASH W-Beam Guardrail RWM04a	2	-
14	BSI-1102027-00	Washer, Square	1	1
15	BSI-2001886	Bolt HH $\frac{5}{8}$ -11 x 7, 2in Threads	1	1
16	BSI-2001885	Bolt HH $\frac{3}{4}$ -10 x 3, Fully Threaded	4	4
17	4001115	Guardrail Bolt $\frac{5}{8}$ -11 x 1- $\frac{1}{4}$	*32	-
18	2001840	Guardrail Bolt $\frac{5}{8}$ -11 x 10	4	-
19	2001636	Wshr $\frac{5}{8}$ F436	2	2
20	4001116	Guardrail Nut Recessed $\frac{5}{8}$ -11	*39	3
21	BSI-2001888	Bolt CH $\frac{5}{8}$ -11 x 2 Fully Threaded	1	1
22	BSI-1701063-00	Bracket, Delineation Mounting	1	1
23	BSI-2001887	Screw SD, HH $\frac{1}{4}$ -20 x $\frac{3}{4}$, 410 SS	6	6
24	4002051	Guardrail Wshr Rect AASHTO	1	1

* Additional quantity of 8 each are required to complete the installation at the existing rail system and are **NOT** supplied in the kit or system.

Step 1 - Post Assembly and Installation

Dimension	
A	31" DOWNSTREAM GUARDRAIL
B	75" (1905mm) O.C. (Off Center)
C	72-3/4" (1848mm) O.C.
D	7-5/8" (194mm) Offset
E	37-1/2" (953mm) O.C.
F	31-7/8" (810mm) ALL POSTS

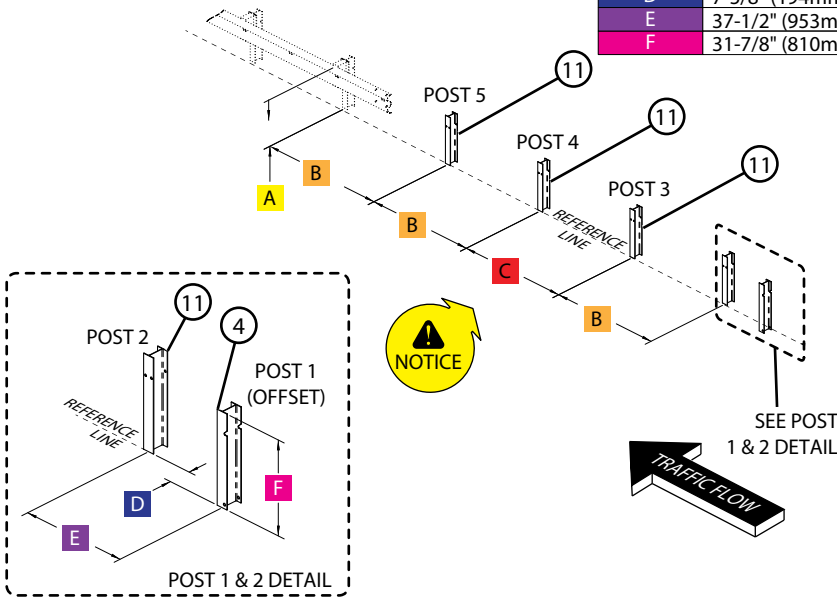

Item #	Part #	Description	QTY
4	BSI-161006-00	Post, I-BEAM, W 6 x 9, 6ft. (Post 1)	1
11	BSI-1012078-00	Line Post	4

The MAX-Tension® TL-2 guardrail end terminal is designed to attach to 31" W-beam guardrail systems. If the existing rail system is not 31" in height, ensure the guardrail end terminal is properly transitioned per Federal, State, and Local standards.

1.1 Install posts (items 11 & 4) in the configuration shown. Ensure post height and post spacing follow the dimensions above.

NOTE: Slot on post 1 (item 4) is facing upstream.

NOTE: The spacing between post 3 and post 4 is unique.

NOTE: The spacing between post 1 and post 2 is unique.

NOTE: The detail above depicts a tangent system without an offset. If applying an allowable offset of 0-2 Ft., modify the post offsets accordingly.

Step 2 - Ground Strut and Soil Anchor Installation

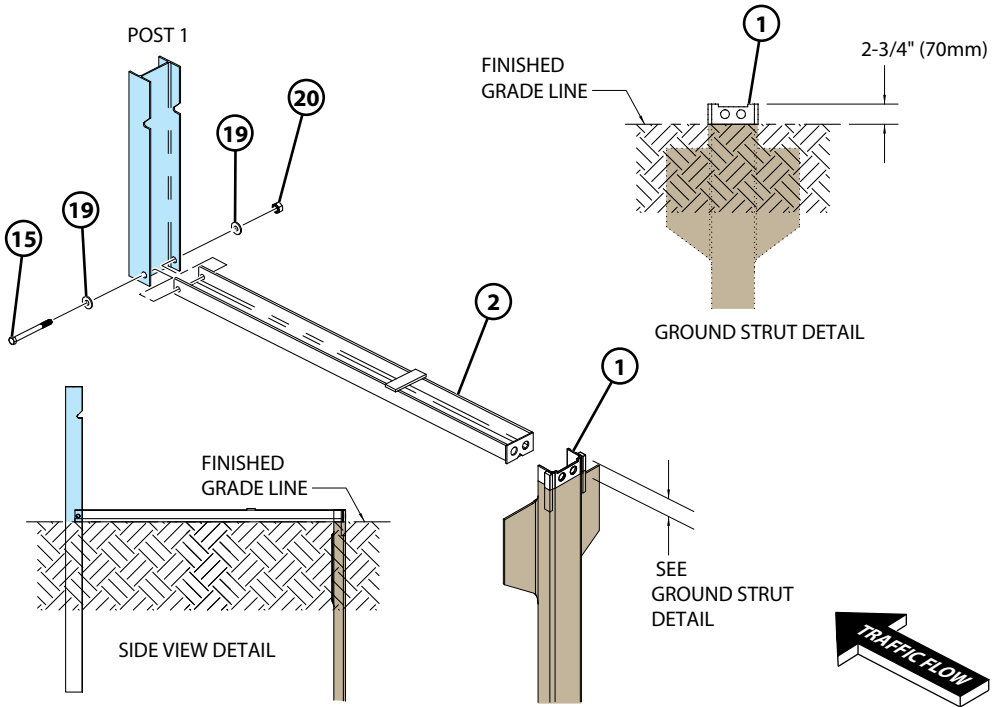

Item #	Part #	Description	QTY
1	BSI-1610060-00	Soil Anchor	1
2	BSI-1610061-00	Ground Strut	1
15	BSI-2001886	Bolt HH $\frac{5}{8}$ -11 x 7, 2in Threads	1
19	2001636	Wshr $\frac{5}{8}$ F436	2
20	4001116	Guardrail Nut Recessed $\frac{5}{8}$ -11	1

NOTE: To facilitate placement of the soil anchor (item 1), put the ground strut (item 2) in place prior to driving the soil anchor ensuring the ground strut is parallel to the system.

- 2.1 Assemble the soil anchor (item 1) flush to the ground strut (item 2) with hardware (items 15, 19, & 20) in configuration shown.
- 2.2 Tighten all hardware.

Step 3 - Blockout Installation

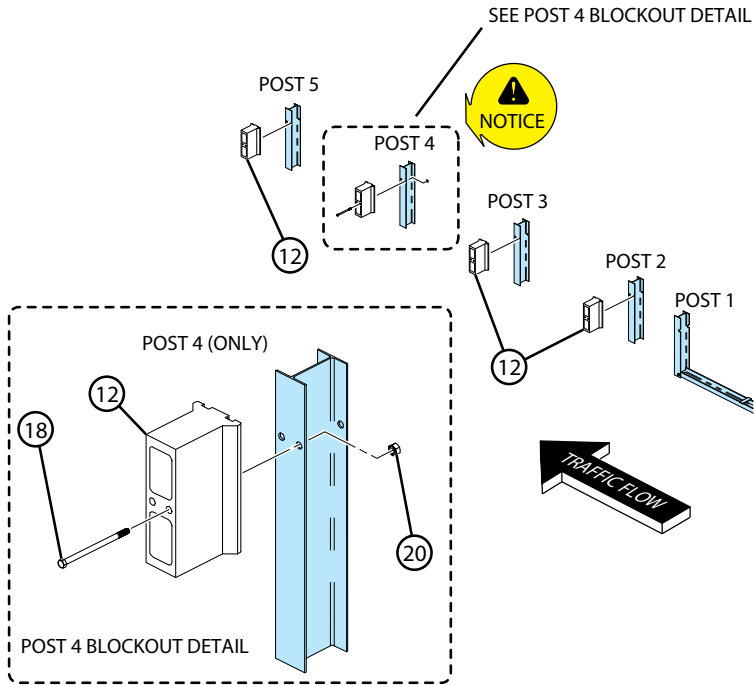

Item #	Part #	Description	QTY
12	B090534	W-Beam Composite Blockout 8in	4
18	2001840	Guardrail Bolt $5/8$ -11 x 10	1
20	4001116	Guardrail Nut Recessed $5/8$ -11	1

NOTE: Only posts 2-5 require a blockout. Do not install blockout on post 1.

- 3.1 Install the blockouts (item 12) in the configuration shown.
- 3.2 Secure blockout (item 12) on post 4 with hardware (items 18 & 20) as shown.
- 3.3 Tighten all hardware.

NOTE: The blockout must be secured to post 4 before hanging the rail using hardware items 18 and 20 as listed in the table above.

Step 4 - Assemble Inner Side Slider (ISS) Panel on Rail 2

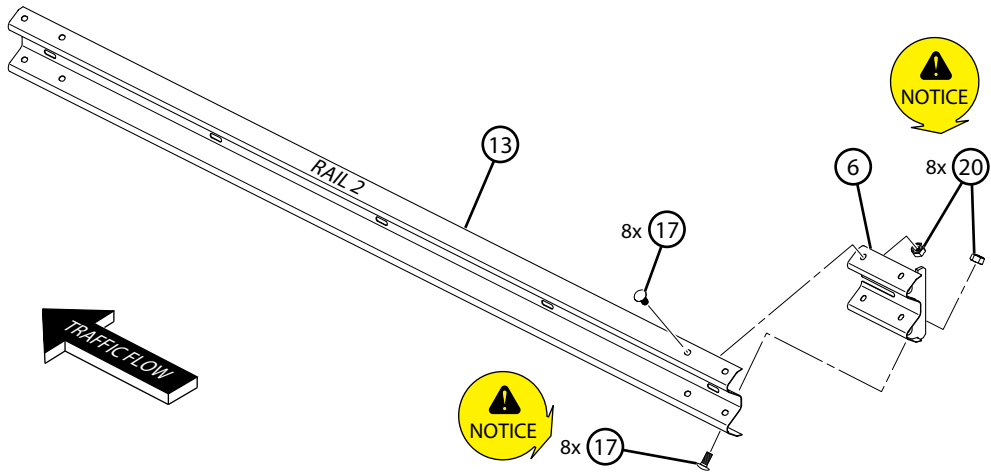

Item #	Part #	Description	QTY
6	BSI-1610065-00	Inner Side Slider (ISS) Panel	1
13	BSI-4004386	MASH W-Beam Guardrail RWM04a	1
17	4001115	Guardrail Bolt $\frac{5}{8}$ -11 x 1- $\frac{1}{4}$	8
20	4001116	Guardrail Nut Recessed $\frac{5}{8}$ -11	8

- 4.1 Prior to installing rail 2 (item 13), secure the inner side slider (ISS) panel (item 6) on upstream end of rail 2 (item 13) using hardware (items 17 & 20).

NOTE: Secure ISS on the non-traffic side of the rail.

⚠ DANGER **BOLTS SHALL BE INSTALLED WITH THE BOLT HEADS ON THE TRAFFIC SIDE AND NUTS ON THE NON-TRAFFIC SIDE.**

- 4.2 Tighten all hardware.

Step 5 - Install Rail 2

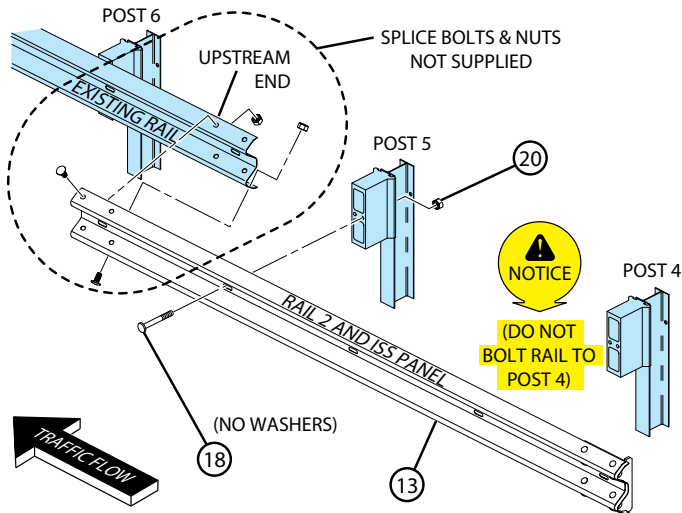

Item #	Part #	Description	QTY
18	2001840	Guardrail Bolt $5/8$ -11 x 10	1
20	4001116	Guardrail Nut Recessed $5/8$ -11	1

⚠ DANGER RAIL 2 IS LAPPED OVER TOP OF THE EXISTING RAIL. THIS IS DONE REGARDLESS OF AN UPSTREAM OR DOWNSTREAM END SYSTEM POSITION.

5.1 Install the preassembled rail 2 with attached inner side slider (ISS) panel in configuration shown in Step 4.

NOTE: Hardware used to splice rails 2 and the existing rail is not supplied with the system. This hardware shall be supplied by the end user.

NOTE: Bolts shall be installed with the bolt heads on the traffic side and nuts on the non-traffic side.

NOTE: Do not install any type of washer (e.g., rectangular washer) or delineator between the post bolt head and the guardrail.

NOTE: Rail 2 is not bolted at post 4. Ensure that the blockout on post 4 has already been secured with a bolt (See Step 3).

5.2 Tighten all hardware.

Step 6 - Assemble Traffic Side Slider (TSS) and Tooth on Rail 1

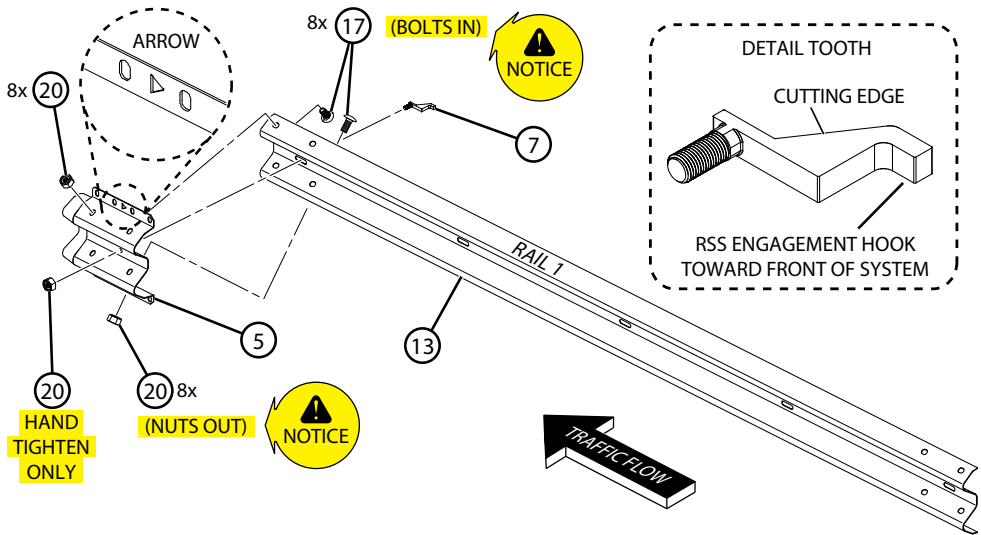

Item #	Part #	Description	QTY
5	BSI-1610064-00	Traffic Side Slider (TSS) Panel	1
7	BSI-1610066-00	Tooth	1
13	BSI-4004386	MASH W-Beam Guardrail RWM04a	1
17	4001115	Guardrail Bolt $5/8$ -11 x 1- $1/4$	8
20	4001116	Guardrail Nut Recessed $5/8$ -11	9

- 6.1 Prior to installing rail 1 (item 13), assemble the traffic side slider (TSS) panel (item 5) and tooth (item 7) on the trailing end of rail 1 (item 13) in the configuration shown.
- 6.2 Secure the traffic side slider (TSS) panel (item 5) to the outside of rail 1 (item 13) using hardware (items 17 & 20). The arrow shall point toward the front of the system.

⚠ DANGER BOLTS SHALL BE INSTALLED WITH THE BOLT HEADS ON THE NON-TRAFFIC SIDE AND NUTS ON THE TRAFFIC SIDE.

- 6.3 Secure the tooth (item 7) using nut (item 20). Only hand tighten at this time. The RSS engagement hook on the tooth shall point toward the front of the system.
- 6.4 Tighten all hardware except the nut (item 20) on the tooth (item 7). The nut will be tightened during Step 12.

Step 7 - Install Rail 1

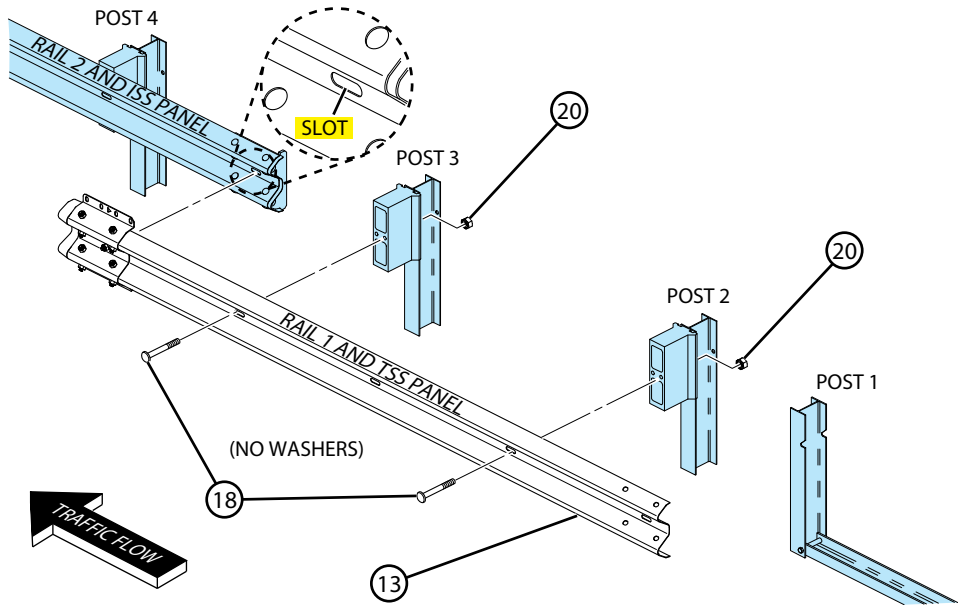

Item #	Part #	Description	QTY
18	2001840	Guardrail Bolt $5/8$ -11 x 10	2
20	4001116	Guardrail Nut Recessed $5/8$ -11	2

⚠ DANGER RAIL 1 IS LAPPED OVER TOP OF RAIL 2. THIS IS DONE REGARDLESS OF AN UPSTREAM OR DOWNSTREAM END SYSTEM POSITION.

NOTE: Rails 1 and 2 will not be spliced together. When installing rail 1 over rail 2, ensure the tooth goes through elongated slot on rail 2.

- 7.1 Install the preassembled rail 1 with attached traffic side slider (TSS) panel and tooth in configuration shown ensuring the tooth goes through the slot on rail 2.
- 7.2 Secure rail 1 to post 2 and post 3 using hardware (items 18 & 20).

NOTE: Do not install any type of washer (e.g., rectangular washer) or delineator between the post bolt head and the guardrail.

- 7.3 Tighten all hardware.

Step 8 - Install Impact Head

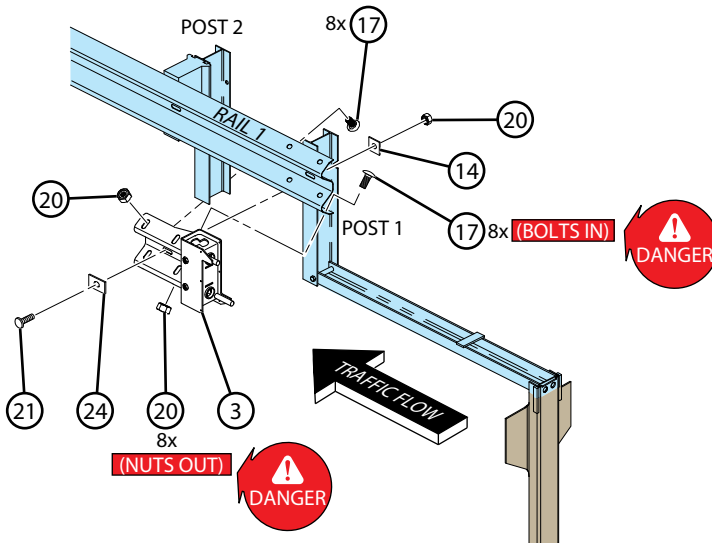

Item #	Part #	Description	QTY
3	BSI-1610062-00	Impact Head	1
14	BSI-1102027-00	Washer, Square	1
17	4001115	Guardrail Bolt $\frac{5}{8}$ -11 x 1- $\frac{1}{4}$	8
20	4001116	Guardrail Nut Recessed $\frac{5}{8}$ -11	9
21	BSI-2001888	Bolt CH $\frac{5}{8}$ -11 x 2 Fully Threaded	1
24	4002051	Guardrail Wshr Rect AASHTO	1

⚠ DANGER ALWAYS LAP THE IMPACT HEAD OVER RAIL 1.

- 8.1 Install the impact head (item 3) in configuration shown.
 - 8.2 Splice the impact head (item 3) to rail 1 using hardware (items 17 & 20).
- NOTE:** Bolts shall be installed with the bolt heads on the non-traffic side and nuts on the traffic side.
- 8.3 Secure the impact head (item 3) and rail 1 to post 1 in the configuration shown.
 - 8.4 Ensure that the rectangular washer (item 24) is placed between the post bolt head (item 21) and the impact head (item 3) and that the square washer (item 14) is used on the backside between post 1 and the nut (item 20).
 - 8.5 Tighten all hardware.

Step 9 - Install Cables

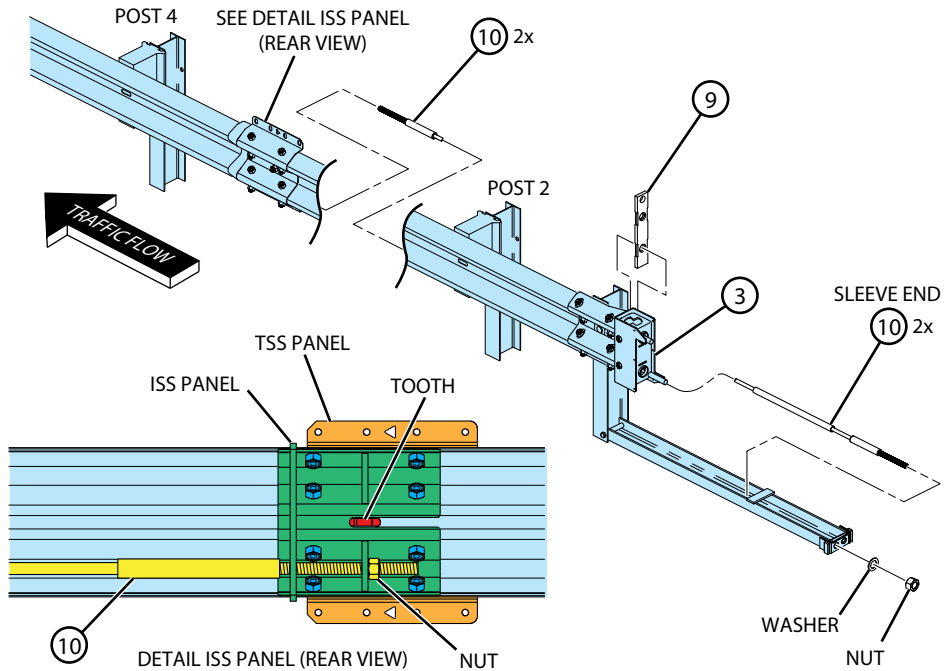

Item #	Part #	Description	QTY
9	B061058	BSI, Cable Friction Plate	1
10	BSI-1612013-00	TL-2 Cable Assembly (Incl. Sleeve, Nuts & Washers)	2

- 9.1 Install the friction plate (9) and cables (10) in configuration shown.
- 9.2 **IMPORTANT:** Insert the end of the cables with the sleeve into the ground strut one at a time and secure with nut and washer provided with cable. **DO NOT** tighten at this step. The sleeve shall rest between the impact head and tabs on the ground strut. The sleeve shall rest a minimum of 6 inches below the impact head.
- NOTE:** The cable closest to the traffic side of the system must pass through the bottom hole of the impact head. The second cable must pass through the top hole.
- 9.3 Ensure that the friction plate (item 9) is inserted through the top of the impact head (3) while passing the cables (item 10) through the impact head (item 3).
- 9.4 Pass the cables (item 10) along the backside of rail 1 until reaching the ISS panel. Ensure that the threads on the cable pass through the holes on the ISS panel and secure cable with nut supplied with cable. **DO NOT** tighten the cables at this time.

Step 10 - Turn Friction Plate

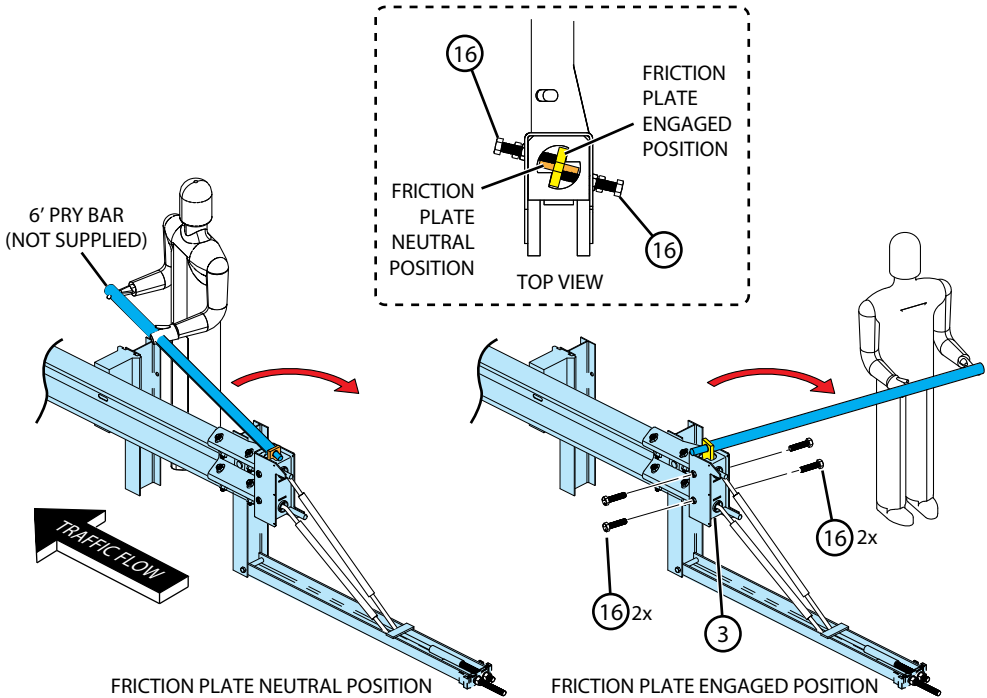

Item #	Part #	Description	QTY
16	BSI-2001885	Bolt HH $\frac{3}{4}$ -10 x 3, Fully Threaded	4

- 10.1 Partially install bolts (item 16) on the side of the impact head (item 3) in configuration shown.
- 10.2 Using a pry bar, turn the friction plate as in configuration shown.
- 10.3 Tighten the bolts (item 16) on the side of the impact head (item 3) and turn the friction plate simultaneously until the friction plate reaches its engaged position and the bolts are completely tightened.

⚠ WARNING Once the friction plate has been turned, the cables cannot be reused.

⚠ CAUTION A minimum of two people should be used to turn the friction plate.

Step 11 - Tighten Cables

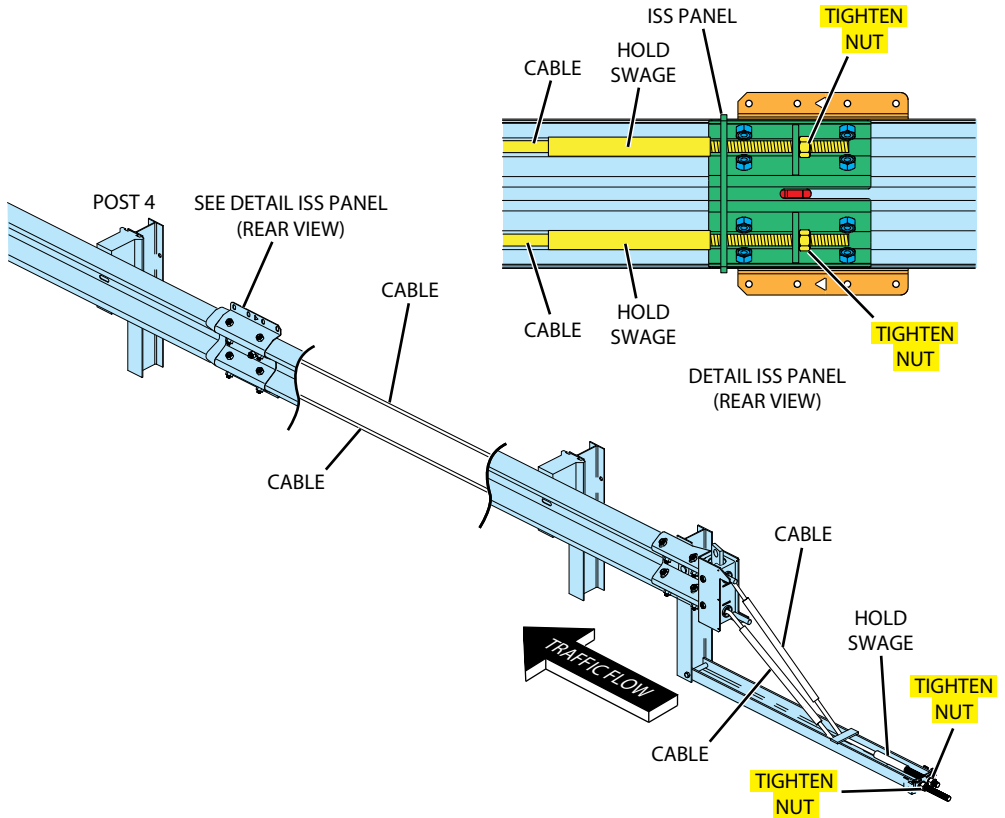

- 11.1 Tighten cable nuts both front and rear in configuration shown.
- 11.2 While tightening the cables, ensure that the cable does not spin by holding the swage with large pliers or pipe wrench.
- 11.3 Tighten until there is no visible sag in the cables.

Step 12 - Install Rear Side Slider (RSS) Plate and Tighten Tooth

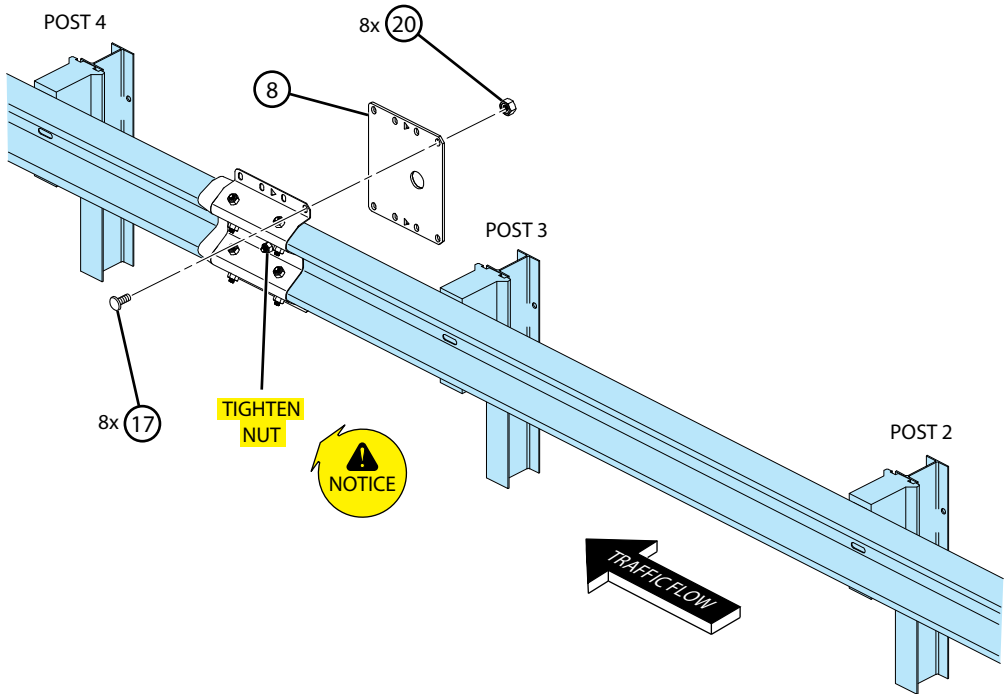

Item #	Part #	Description	QTY
8	BSI-1610067-00	Rear Side Slider (RSS) Plate	1
17	4001115	Guardrail Bolt $\frac{5}{8}$ -11 x 1- $\frac{1}{4}$	8
20	4001116	Guardrail Nut Recessed $\frac{5}{8}$ -11	8

12.1 Install rear side slider (RSS) plate (8) in configuration shown using hardware (items 17 & 20).

NOTE: Bolts shall be installed with the bolt heads on the traffic side and nuts on the non-traffic side.

NOTE: Ensure that the arrows on the TSS and RSS are aligned and facing the front of the system towards the impact head and the tooth passes through the RSS plate opening.

12.2 Tighten the nut securing the tooth that was hand tightened in Step 6.

12.3 Tighten all remaining hardware.

Step 13 - Install Delineation Bracket

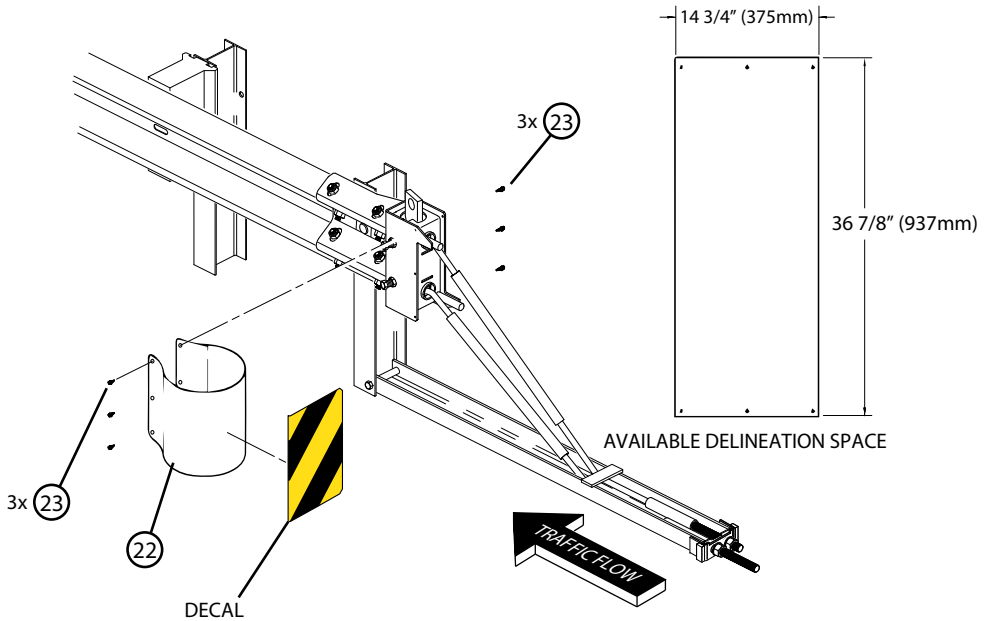

Item #	Part #	Description	QTY
22	BSI-1701063-00	Bracket, Delineation Mounting	1
23	BSI-2001887	Screw SD,HH 1/4-20 x 3/4, 410 SS	6

- 13.1 Apply delineation decal per Federal, State, and Local Standards.
- 13.2 Install delineation bracket (item 22) in configuration shown using screw (item 23).
- 13.3 Tighten all hardware.

Inspector Checklist Confirm all items in checklist have been properly completed and hardware is tightened.

Inspection		
Date	By	Item
		Cable closest to the traffic side of the system passes through bottom hole on impact head. (Pg. 24, Step 9)
		Cable sleeves are at the front of the system. The sleeves shall rest a minimum of 6 inches below the impact head. (Pg. 24, Step 9)
		No blackout at post 1. (Pg. 18, Step 3)
		Slot on post 1 is on upstream end of the system. (Pg. 16, Step 1)
		Guardrail nuts on impact head are on the outside. (Pg 23, Step 8)
		Rectangular washer and square washer used at post 1. (Pg 23, Step 8)
		Friction plate is installed inside impact head with cables in the proper position. (Pg. 24, Step 9)
		Friction plate is turned to engaged position with cables in the proper position. (Pg. 25, Step 10)
		Friction plate bolts are completely tightened with cables in the proper position. (Pg. 25, Step 10)
		Impact head spliced to rail 1 with guardrail nuts on outside. (Pg 23, Step 8)
		Slider Joint - traffic side slider (TSS) should be attached to downstream end of rail 1 with nuts on the traffic side and arrow pointing toward the front of the system. (Pg. 21 Step 6)
		Slider Joint - inner side slider (ISS) should be attached to the upstream end of rail 2 with nuts on the non-traffic side. (Pg. 19, Step 4)
		Slider Joint - rear side slider (RSS) should be attached with the nuts on the non-traffic side and arrow pointing toward the front of the system. (Pg. 27, Step 12)
		8 bolts should connect the TSS to the RSS. Bolts should pass from the TSS to the RSS. (Pg. 27, Step 12)
		Tooth is installed and engaged in the slot at the slider joint. (Pg. 21, Step 6)
		TSS and RSS arrows should be aligned so as to see through them when installed. (Pg. 27, Step 12)
		Tooth should be oriented with RSS engagement hook facing front of system. (Pg. 21, Step 6)
		Cables should be taut and not visibly sagging. (Pg. 26, Step 11)
		System installed without offset or with allowable offset of 0-2 ft. (Pg. 16, Step 1)
		System height shall be 31" +/- 1". (Pg. 16, Step 1)
		All guardrail panels should be lapped with the upstream most rail on the outside. Rail 1 over rail 2, rail 2 over existing rail. (Pg. 22, Step 7)
		Post spacing should be 75" at top of the post for all system spaces except space between posts 1-2, and 3-4. Space between posts 1-2 should measure 37 1/2"; space between posts 3-4 should measure 72 3/4", both measured at top of post. (Pg. 16, Step 1)
		Two washers are installed at the base of post 1 connecting post 1 to the ground strut. (Pg. 17, Step 2)
Inspector signature:		Date:

Maintenance Inspection

Guardrail terminals, like all roadside safety hardware, require inspection to ensure they are in acceptable working condition. Regular inspections of the MAX-Tension® TL-2 system are recommended and shall be made by the Local highway authority. Frequency of the inspections shall be made based on site conditions, traffic volumes, and crash history. Please follow the Local guidelines for frequency of inspections to ensure adequate repairs are made to the system. Walk-up inspections are recommended at least twice a year. The MAX-Tension® TL-2 system shall be inspected for damage after every impact. Repairs shall be made accordingly using Lindsay Transportation Solutions components as specified in the product drawings.

Visual Drive-By Inspections – Recommended Frequency – Monthly

Check for:

- Damage caused by vehicle impacts
- Minor damage cause by impacts from roadside maintenance equipment
- Misalignment
- Missing components
- Damage from vandalism
- Loose hardware

Maintenance Inspection (Cont.)

Walk-Up Inspections – Recommended Frequency – Twice a Year

Before performing walk-up inspections, ensure traffic control is deployed in accordance with Local guidelines.

Check for:

- Damage caused by vehicle impacts
- Minor damage cause by impacts from roadside maintenance equipment
- Misalignment
- Missing components
- Damage from vandalism
- Sagging cables
- Clear and dispose of any debris in and around the system
- Cutting tooth is in correct position
- Disengaged friction plate
- Frayed cable
- Grading around the system
- Loose hardware
- The cable sleeves shall rest a minimum of 6 inches below the impact head.

After inspection is complete, ensure all items identified during the inspection process are corrected. The MAX-Tension® TL-2 System shall be returned to proper condition as outlined in the installation instructions.

Maintenance Inspection (Cont.)

Walk-Up Inspection	
Item	Comment
Damage caused by vehicle impacts	
Minor damage caused by impacts from roadside maintenance equipment	
Misalignment	
Missing components	
Damage from vandalism	
Sagging cables	
Clear and dispose of any debris in and around the system	
Cutting tooth is in correct position	
Disengaged friction plate	
Frayed cable	
Grading around system	
Loose hardware	
The cable sleeves shall rest a minimum of 6 inches below the impact head.	
Inspector Signature:	Date:
Print Name:	Location:

If any of the above items are identified during the walk-up inspection, swift action should be taken to repair and return the MAX-Tension® TL-2 Guardrail Terminal System (MAX TL-2) to the proper condition as outlined in this manual.

In addition to the items listed above, all items in the Inspector Checklist (Pg. 29) should be checked.

Drawings MAX-TENSION TANGENT TL-2 SYSTEM 8" COMPOSITE BLOCKOUTS

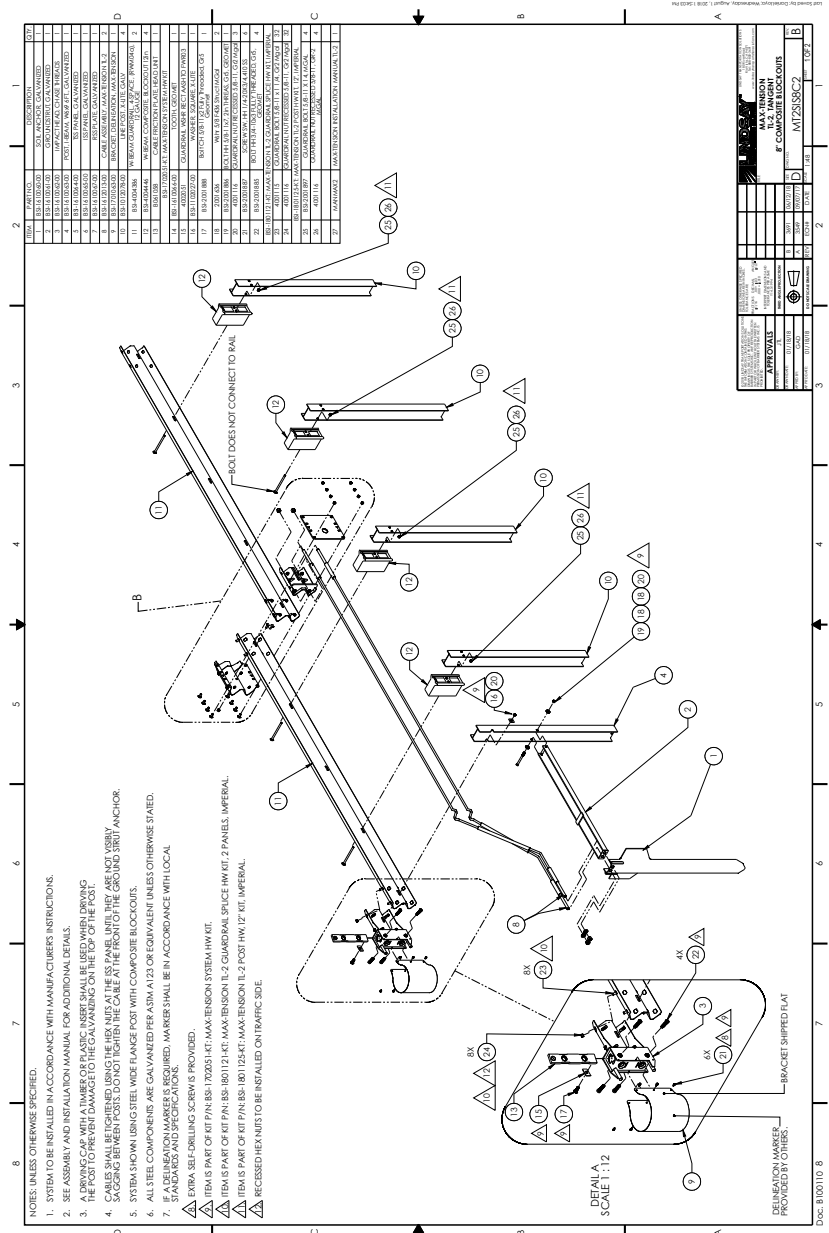

Drawings

MAX-TENSION TANGENT TL-2 SYSTEM 8" COMPOSITE BLOCKOUTS

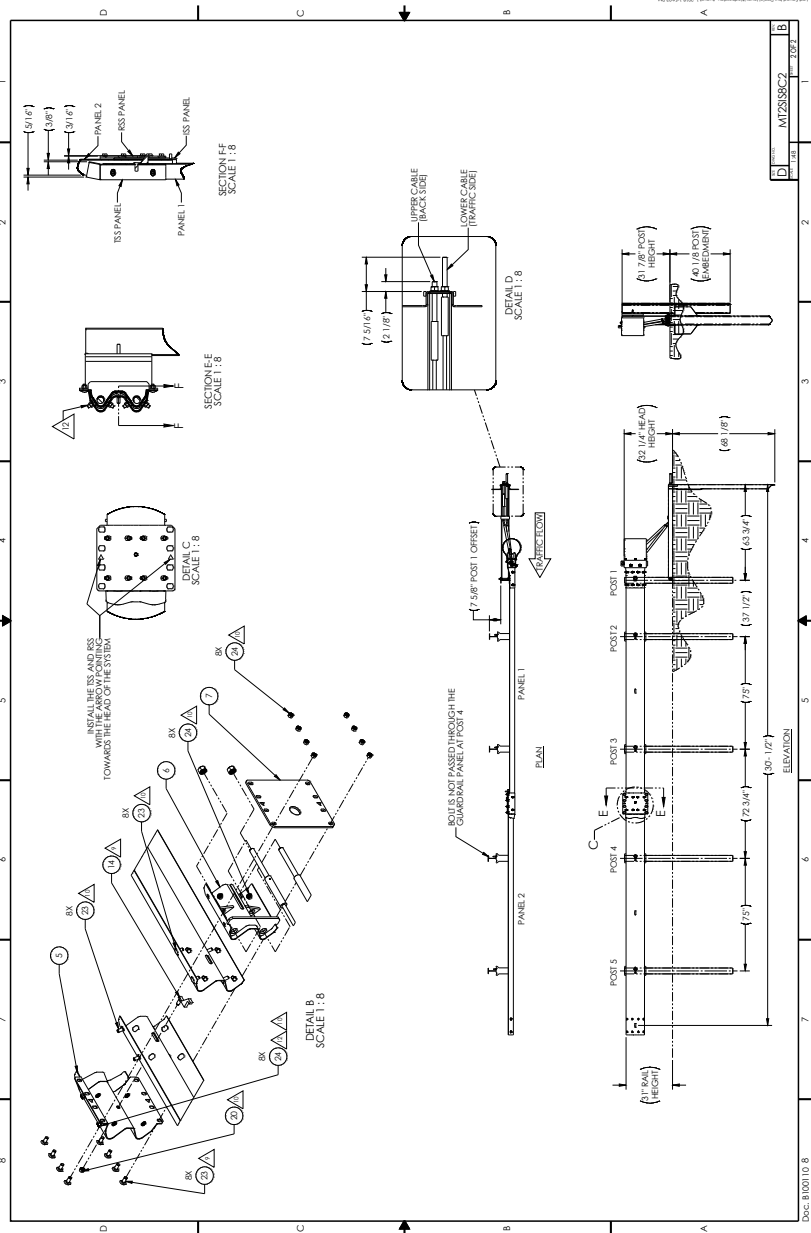

Drawings MAX-TENSION TANGENT TL-2 SYSTEM 8" TIMBER BLOCKOUTS

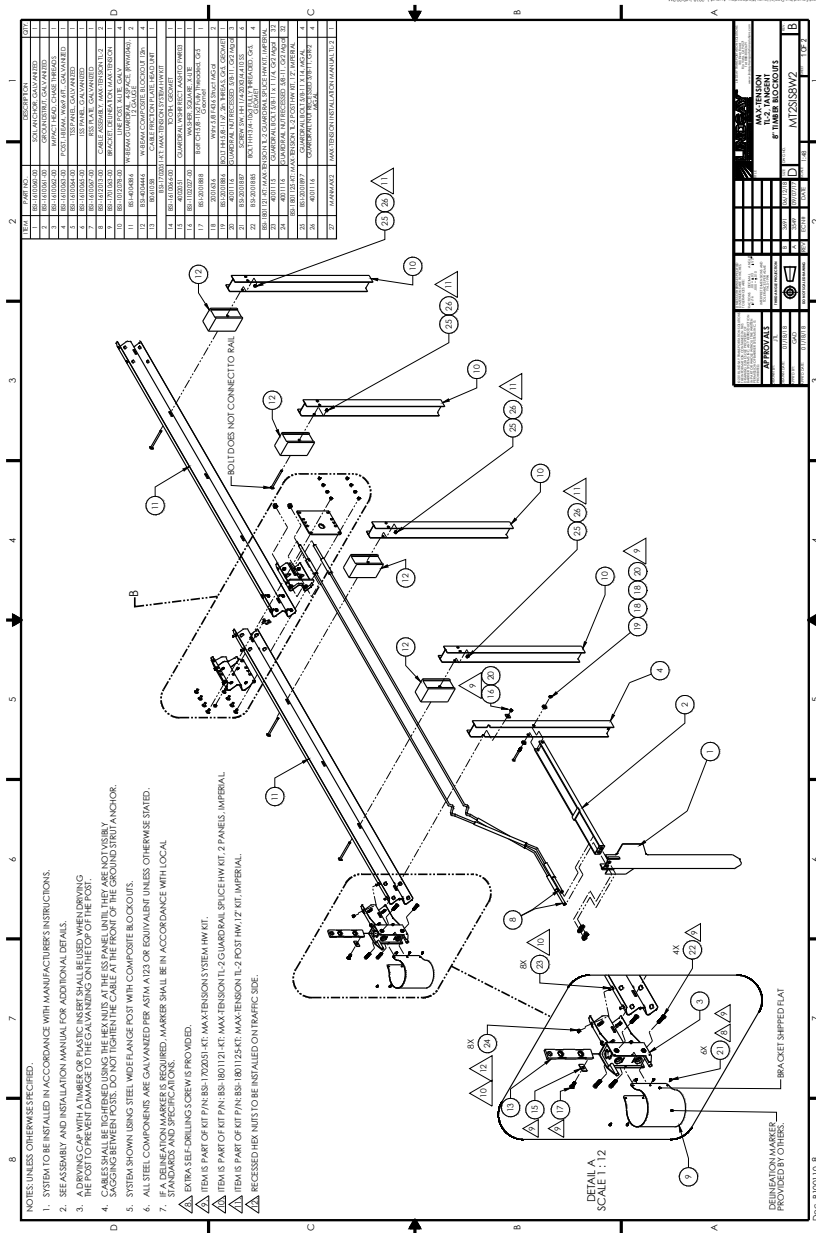

Drawings MAX-TENSION TANGENT TL-2 SYSTEM 8" TIMBER BLOCKOUTS

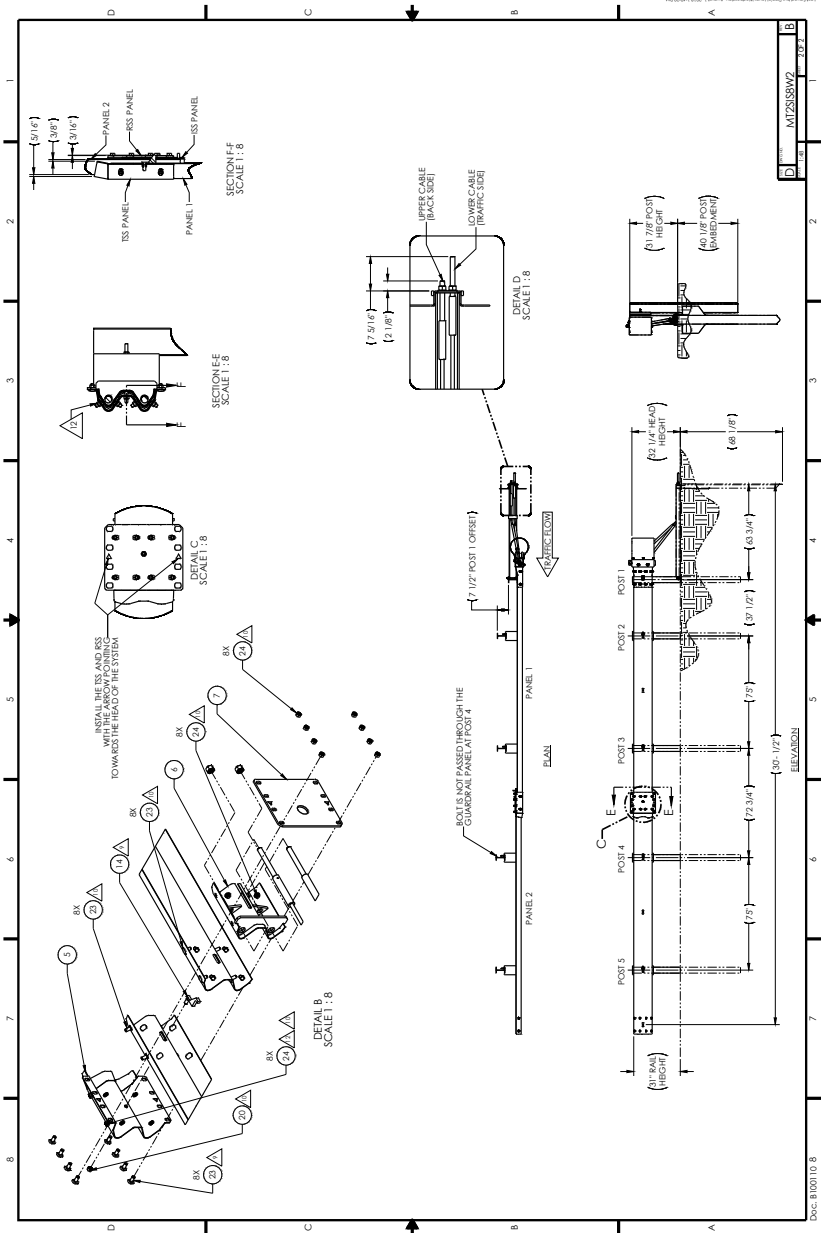

Drawings MAX-TENSION TANGENT TL-2 SYSTEM 12" COMPOSITE BLOCKOUTS

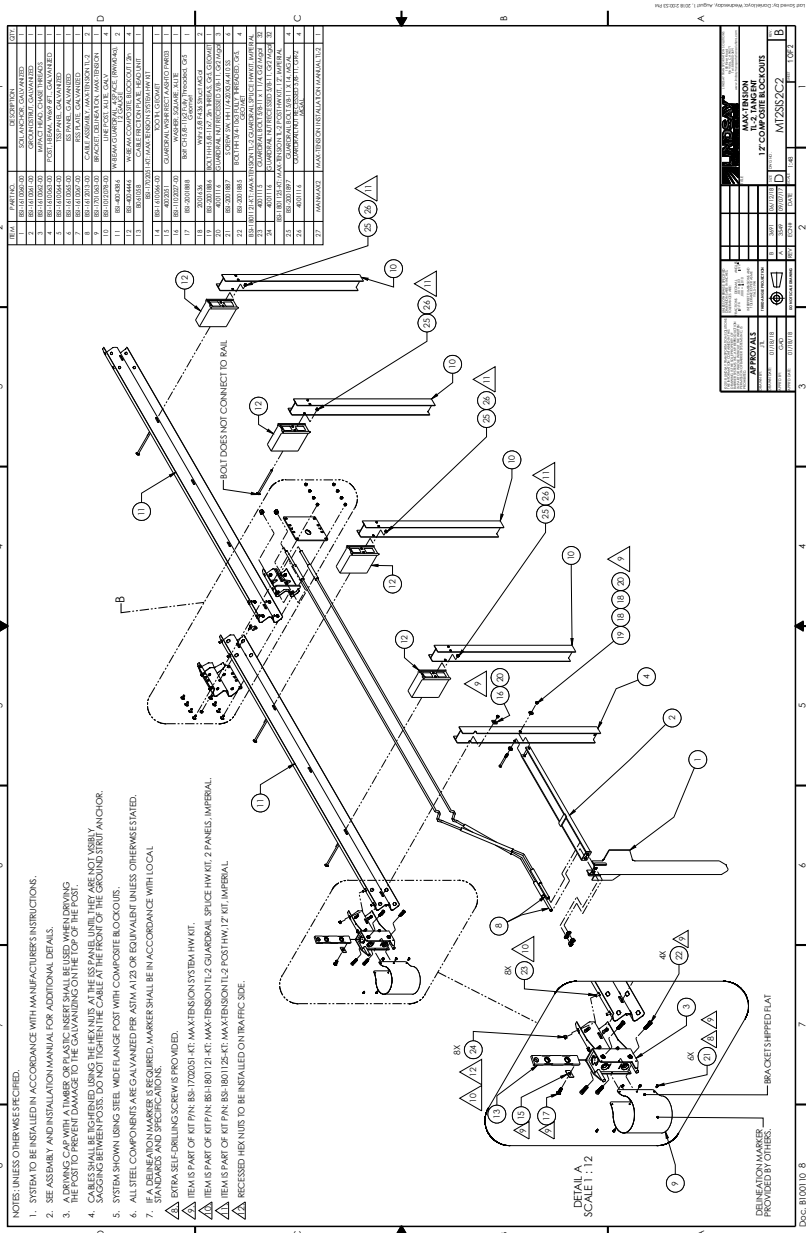

Drawings MAX-TENSION TANGENT TL-2 SYSTEM 12" COMPOSITE BLOCKOUTS

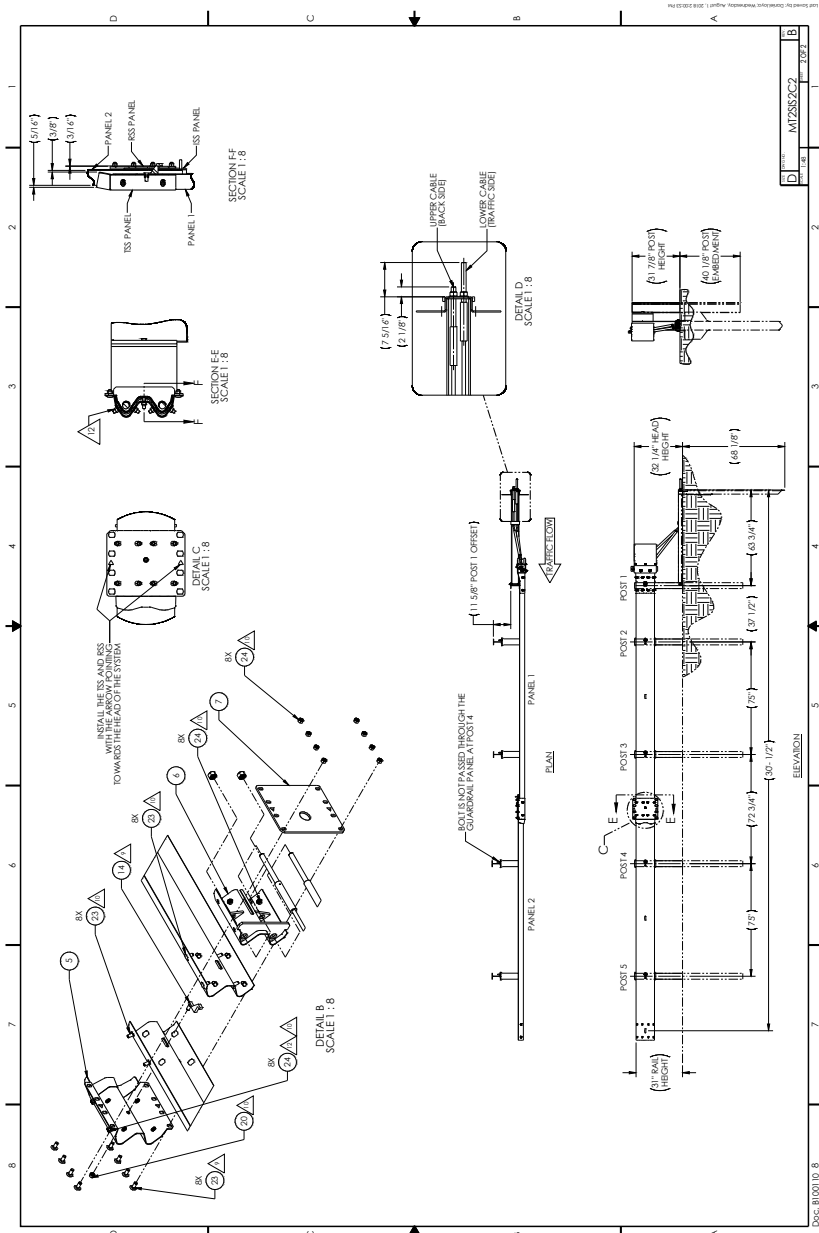

Drawings MAX-TENSION TANGENT TL-2 SYSTEM 12" TIMBER BLOCKOUTS

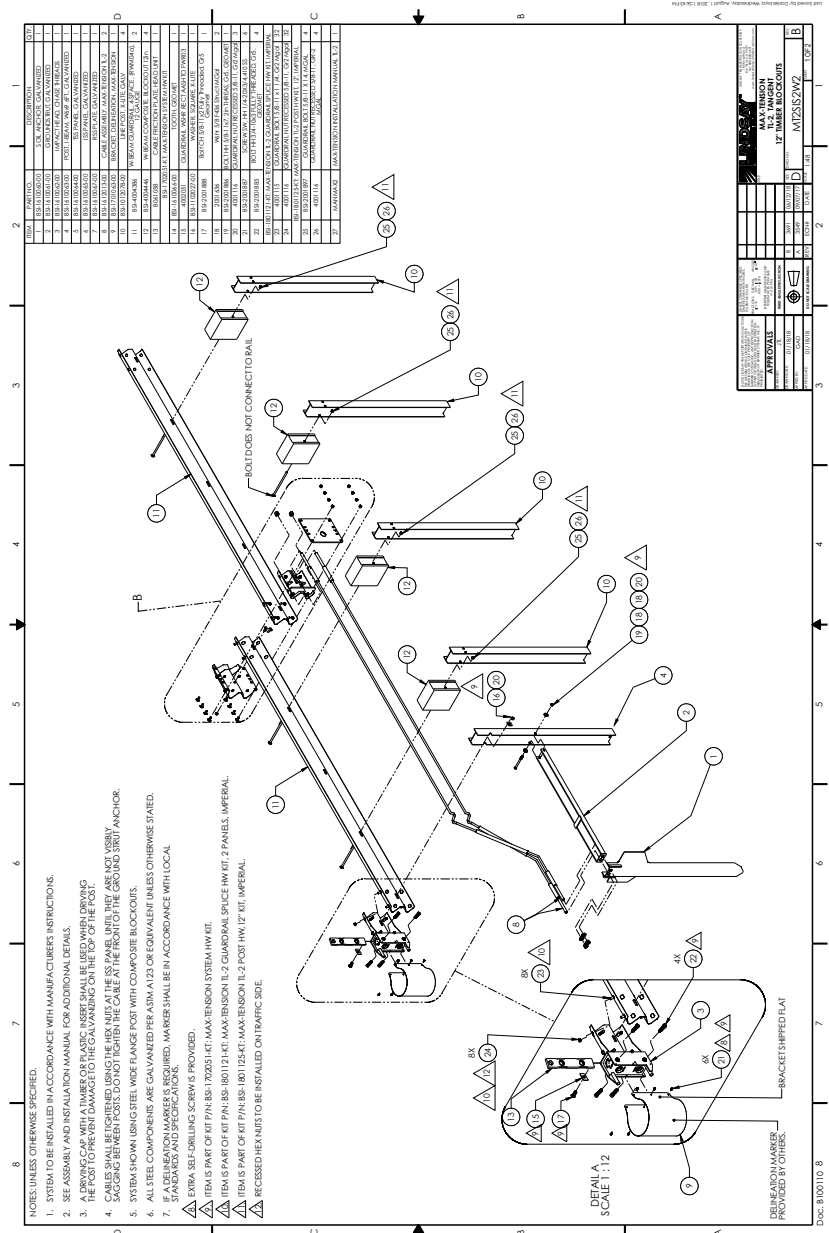

Drawings MAX-TENSION TANGENT TL-2 SYSTEM 12" TIMBER BLOCKOUTS

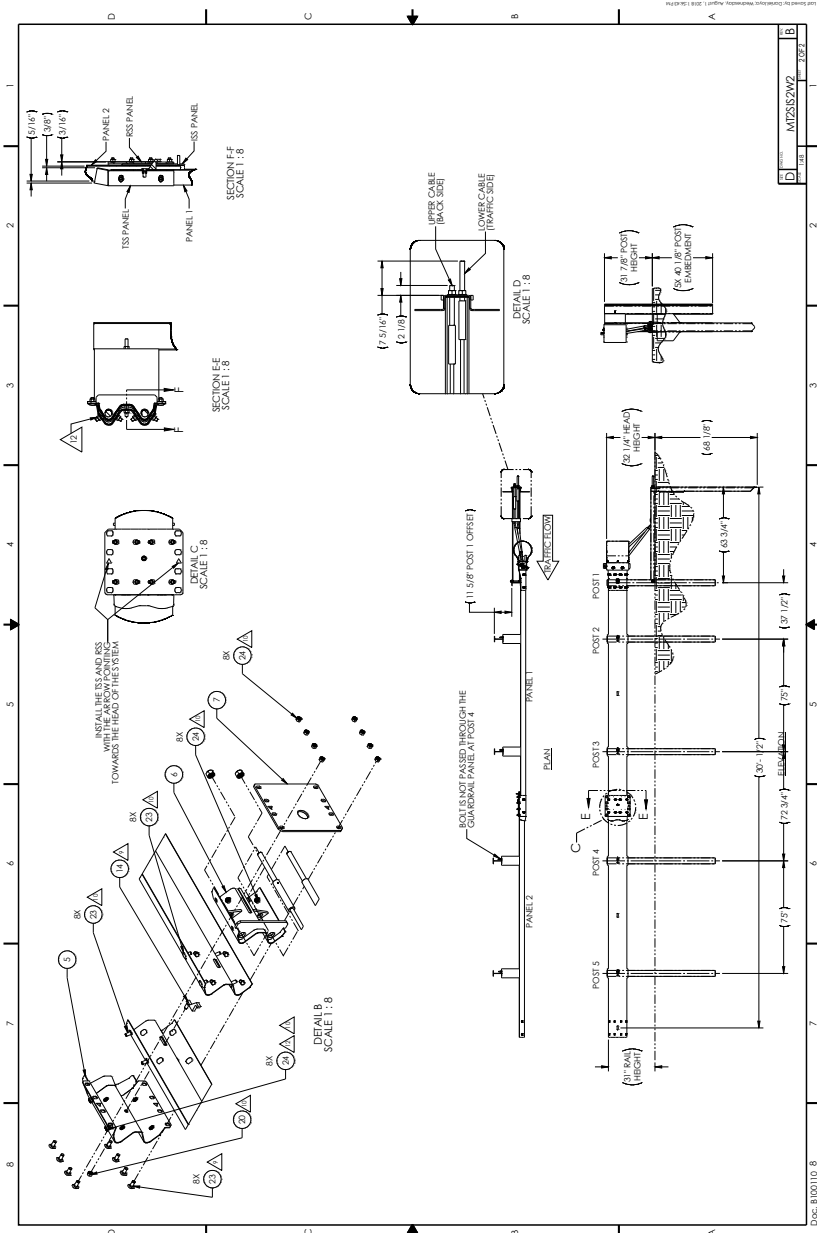

Long-Term Storage

Store materials under cover in dry, well-ventilated conditions, away from doorways open to the environment.

Provide adequate ventilation between stacked pieces. Elevate and separate articles stacked outdoors with spacers (poplar, ash, spruce).

Incline parts to allow for maximum drainage.

Avoid stacking material directly on soil or decaying vegetation.

For crated items, remove the lids to provide better ventilation and drying of the galvanized parts. Customers will need to remove kits packed in cardboard boxes from the crates and store them inside.

Notes

Notes



Lindsay Transportation Solutions

180 River Road • Rio Vista, CA 94571 • +1 707.374.6800 U.S. Toll Free: 888.800.3691 • www.lindsaytransportsolutions.com

Installation manual for the MAX-Tension® TL-2 system is subject to change without notice to reflect improvements and upgrades.

Please contact Lindsay Transportation Solutions to confirm that you are using the most current installation manual and instructions.

Additional information is available from Lindsay Transportation Solutions. © Lindsay Transportation Solutions