

**MATT™**  
**MEDIAN ATTENUATING TREND® TERMINAL**  
**PRODUCT MANUAL**

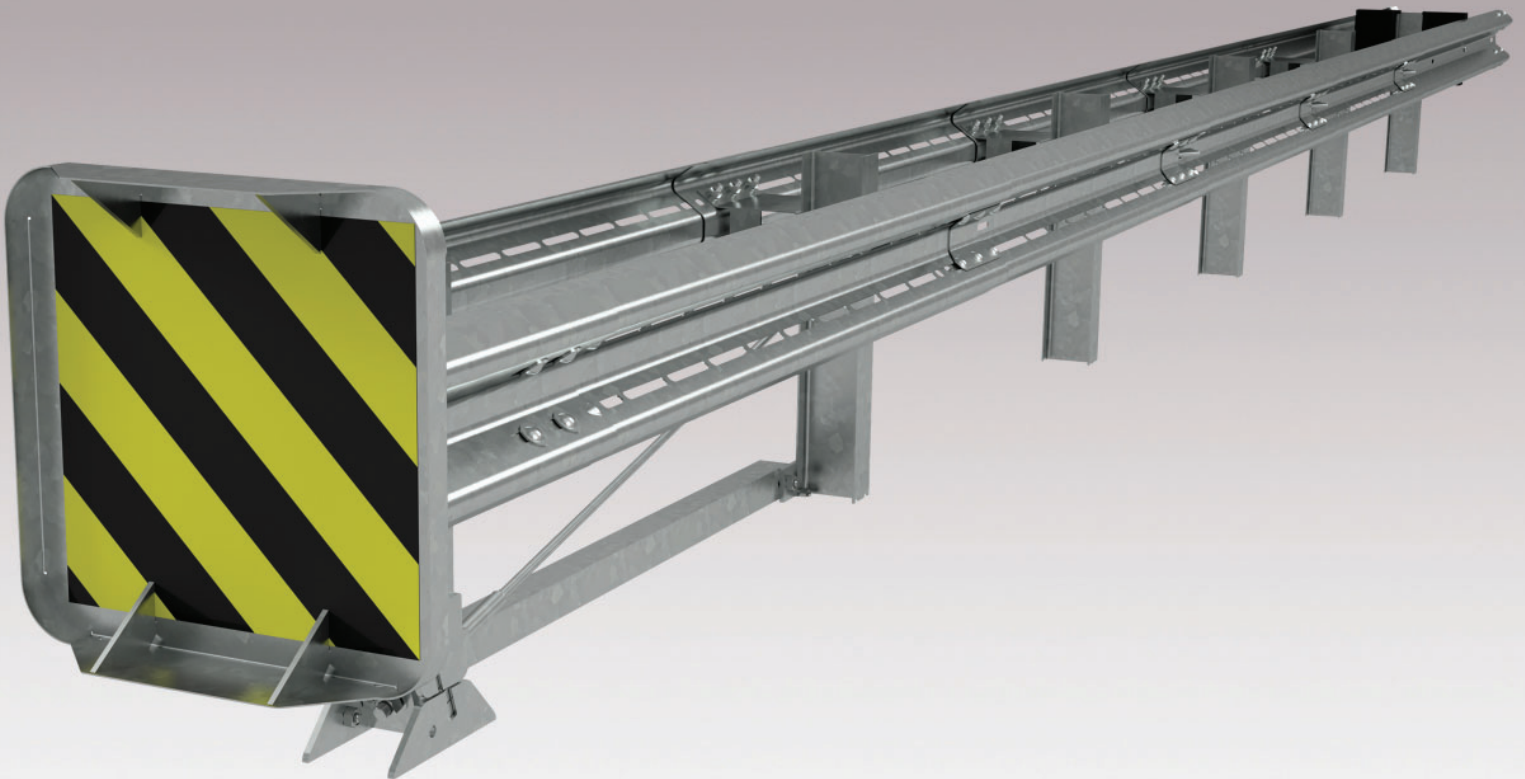

# MATT™

## MEDIAN ATTENUATING TREND® TERMINAL

The Median Attenuating TREND® Terminal (“MATT™”) has been tested to the American Association of State and Highway Transportation Officials (“AASHTO”) Manual for Assessing Safety Hardware, 2<sup>nd</sup> Edition-2016, 2020 Errata (“MASH”) criteria, as a Test Level 3 (“TL-3”) device.

### Product Description Assembly Manual



15601 Dallas Parkway  
Suite 525  
Addison, Texas 75001



**Warning:** The local highway agency, distributors, owners, and contractors are **RESPONSIBLE** for the assembly, maintenance, and repair of the MATT™. Failure to fulfill these **RESPONSIBILITIES** with respect to the assembly, maintenance, and repair of the MATT™ could result in serious injury or death.



**Important:** These instructions are for standard assembly specified by the appropriate highway agency. In the event the specified system assembly, maintenance, or repair would require a deviation from standard assembly parameters, contact a Valtir, LLC (“Valtir”) representative. This system has received a Federal-aid reimbursement eligibility letter (CC-175) from the Federal Highway Administration (“FHWA”) for use on the National Highway System (“NHS”) under strict criteria utilized by that agency.

**This manual must be available to the worker overseeing and/or assembling the product at all times. For additional copies, contact Valtir at (888) 356-2363 or visit [www.valtir.com](http://www.valtir.com).**

The instructions, illustrations, and specifications are based on the latest MATT™ information available to Valtir at publication. We reserve the right to make changes at any time. Please visit [www.valtir.com](http://www.valtir.com) to confirm the latest revision.



# MATT™

The MATT™ is a tangent, double-sided, re-directive/gating and energy absorbing attenuator/end terminal, for use with various longitudinal highway barriers, in either unidirectional or bidirectional traffic applications, to include roadside, shoulder, median and gore installations.

# **Table of Contents**

MATT™ ACRONYMS and ABBREVIATIONS.....	4
Customer Service Contacts .....	4
Limitations and Warnings.....	5
Overview .....	6
Recommended Tools.....	7
Site Preparation .....	8
Post Placement.....	9
Rigid Pavement and Rock.....	9
Inspect Shipment .....	9
MATT™ System Components/Hardware.....	11
Assembly Steps .....	15
STEP 1: MATT™ Post Layout (Posts 1-6).....	16
STEP 2A: MATT™ CR Post 1 Bottom Assembly .....	17
STEP 2B: MATT™ SYTP® With Soil Plate Assembly Post 2 .....	18
STEP 2C: MATT™ SYTP® With Soil Plate W-Shaped Assembly for Post 3 to 5.....	19
STEP 2D: MATT™ Line Post With Soil Plate W-Shaped Assembly for Post 6.....	20
STEP 3: MATT™ Angle Strut Assembly .....	21
STEP 4: MATT™ CR Post 1 Top Assembly .....	22
STEP 5A: MATT™ Double Spacer Assembly Posts 1 and 2 .....	23
STEP 5B: MATT™ Single Spacer Assembly Posts 3 to 5 .....	24
STEP 6: MATT™ 12 Gauge Transition Guardrail with Fin-4, 9'-4 1/2" [2.858 m].....	25
STEP 7: MATT™ 12 Gauge, Slotted Intermediate Guardrail with Fin-3, 6'-3" [1.905 m] Posts 4-5 .....	26
STEP 8: MATT™ 12 Gauge, Slotted Intermediate Guardrail with Fin-3, 6'-3" [1.905 m] Posts 3-4 .....	27
STEP 9: MATT™ 12 Gauge, Slotted Intermediate Guardrail-2, 6'-3" [1.905 m].....	28
STEP 10: MATT™ 10 Gauge, Slotted Front Guardrail-1, 6'3" [1.905 m].....	29
STEP 11: MATT™ Cable Assembly.....	30
STEP 12: MATT™ 10 Gauge Head Rail Assembly, 1'- 9 3/4" [552 mm].....	31
STEP 13: MATT™ Delineation Assembly .....	32
STEP 14: MATT™ Head Tube Assembly .....	33
STEP 15: MATT™ Impact Head Assembly.....	34
STEP 16: MATT™ Nuts To Be Torqued .....	35
MATT™ System Assembly Checklist (File with Project Records).....	36
MATT™ System Repair Checklist (File with Maintenance Records).....	36
MATT™ System Routine Inspection Checklist (File with Maintenance Records) .....	37
APPENDIX A: AASHTO Roadside Design Guide <b>Roadside (Shoulder)</b> Grading Detail .....	38
APPENDIX B: AASHTO Roadside Design Guide <b>Median</b> Grading Detail .....	39
APPENDIX C: Alternate Foundations for Installations.....	40

## **MATT™ ACRONYMS and ABBREVIATIONS**

AASHTO	American Association of State Highway and Transportation Officials
CFR	Code of Federal Regulation
CRP®	Cable Release Post®
FHWA	Federal Highway Administration
Nm	Newton-Meters
MASH	Manual for Assessing Safety Hardware 2 <sup>ND</sup> Edition, published in 2016, (Errata in 2020)
MATT™	Median Attenuating TREND® Terminal
MGS	Midwest Guardrail System
MUTCD	Manual on Uniform Traffic Control Devices
NCHRP	National Cooperative Highway Research Program
NHS	National Highway System
OSHA	Occupational Safety & Health Administration
PPE	Personal Protective Equipment
SYTP®	Steel Yielding Terminal Post®
TL-3	Test Level-3
Valtir	Valtir, LLC

## **Customer Service Contacts**

Valtir is committed to the highest level of customer service. Feedback regarding the MATT™, its assembly procedures, supporting documentation, and performance is always welcome. Additional information can be obtained from the contact information below:

### **Valtir**

Telephone	(888) 356-2363 (USA)
Contact Link	<a href="http://Valtir.com/Contact">Valtir.com/Contact</a>
Website:	www.Valtir.com

**Valtir, LLC**  
**15601 Dallas Parkway**  
**Suite 525**  
**Addison, TX 75001**

## Limitations and Warnings



Valtir, in compliance with MASH, contracts with ISO 17025 A2LA accredited testing laboratories to perform crash tests, evaluate tests, and submit the test results to the FHWA for review.

MATT was tested to MASH-2nd Edition (2016), with 2020 Errata TL-3 criteria and may be used in Test Level 1, Test Level 2, and Test Level 3 applications – when installed at the full Test Level 3 system length of 34' 4-1/2" [10.477 m]. These tests typically evaluate product performance defined by MASH involving a range of vehicles on roadways, approximately 1,100kg [2,420 lb.] and full size pickup trucks, approximately 2,270 kg [5,000 lb.] at 100 kph [62 mph].

**The MATT™ is tested pursuant to the test matrix criteria of MASH as designated by AASHTO and FHWA. The FHWA/AASHTO tests are not intended to represent the performance of systems when impacted by every vehicle type or in every impact condition existing on the roadway. Every departure from the roadway is a unique event.**

Valtir expressly disclaims any warranty or liability for injury or damage to persons or property resulting from any impact, collision or harmful contact with its products, other vehicles, or nearby hazards or objects by any vehicle, object or person, whether or not the products were assembled in consultation with Valtir or by third parties.

The MATT™ is intended to be assembled, delineated, and maintained within the state/specifying agency and federal guidelines. It is important for the state/specifying agency to select the most appropriate product configuration for site specifications.

**The state/specifying agency's careful evaluation of the site layout, vehicle population type and speed, traffic direction, and visibility are some of the elements that require evaluation in the selection of a highway product. For example, curbs could cause an untested effect on an impacting vehicle.**

After an impact with the system, all debris must be removed from the area immediately in compliance with the most applicable state/specifying agency policy. The specified MATT™ must be evaluated and restored to its original specified condition or replaced as the state/specifying agency determines/requires, as soon as possible. Product selection, approval, proper installation, and maintenance of any highway product is the sole responsibility of the state/specifying agency.

**Under NO circumstances shall the rail within the MATT™ be curved/radiused, between Post 1 and Post 6.**

All metric dimensions are “soft conversions” and as such should be considered as reference only.

**Safety Alert Symbols appear throughout this manual and indicate Danger, Warning, Caution or Important statements. Failure to read and follow these warnings could result in serious injury or death in the event of a vehicle impact with the system.**

**WARNING: Do not assemble, maintain, or repair the MATT™ until you have read this manual thoroughly and completely understand it. Ensure that all Danger, Warning, Caution, and Important statements within the manual are completely followed. Please call Valtir at (888) 356-2363 if you have any questions about instructions in this manual.**

**WARNING: Safety measures incorporating appropriate traffic control devices and personal protective equipment ("PPE") specified by the state/specifying agency must be used to protect all personnel while at the assembly, maintenance, or repair site. Work gloves, apron, eye protection, safety-toe shoes, and back protection shall be used.**

**WARNING: Ensure the assembly site meets all appropriate Manual on Uniform Traffic Control Devices ("MUTCD") and the state/specifying agency standards.**

**WARNING: Use only Valtir parts that are specified by Valtir for use with the MATT™ for assembling, maintaining, or repairing the MATT™. Do not utilize or otherwise commingle parts from other systems even if those systems are other Valtir or Systems. Such configurations have not been tested, nor have they been approved for use. Assembly, maintenance or repairs using unspecified parts or accessories is strictly prohibited. Failure to follow this warning could result in serious injury or death in the event of a vehicle impact with such an UNACCEPTED system.**

**WARNING: Do NOT modify the MATT™ in any way.**

**IMPORTANT: Valtir makes no recommendation whether use or reuse of any part of the MATT™ is appropriate or acceptable after system impact. It is the responsibility of the state/specifying agency and its engineers to make that determination.**

**IMPORTANT: It is the responsibility of owner, state/specifying agency, or specifier to inspect the MATT™ after assembly is complete to ensure the instructions provided in this manual have been strictly followed.**

# Overview

The MATT™ has a system length of 34'-4 1/2" [10.477 m] long and is a tangent, 31" [787 mm] (+1" -0") [+25 mm, -0 mm] high, double-sided, re-directive/gating and energy absorbing attenuator/end terminal available for use with various longitudinal highway barriers, in either unidirectional or bidirectional traffic applications.

The MATT™ consists of MATT™ 10 and 12 gauge slotted guardrail, MATT™ 12 gauge transition guardrail with an integrated fin and MATT™ 12 gauge slotted guardrail with an integrated fin, MATT™ 10 gauge head rail, MATT™ impact head, MATT™ CR top and bottom posts, MATT™ SYTP® with soil plate, MATT™ system line post with soil plate, MATT™ angle strut, MATT™ cable assembly, MATT™ spacers, MATT™ Backing Plates, composite offset blocks and various other required hardware components.

When connecting the MATT™ to Median MGS using offset blocks other than 8" [200 mm] – such as Median MGS utilizing 12" [300 mm] offset blocks – refer to the AASHTO Roadside Design Guide (current edition) for appropriate minimum taper/flare rates for barrier design. Valtir does offer a MATT™ transition to MGS Median Barrier with 12" blocks drawing for the specifying agency's use.

When connecting the MATT™ to W-beam guardrail heights other than 31" [787 mm], or rigid or semi-rigid barriers, (i.e. concrete barrier, thrie beam, wall or bridge pier) a transition will be required - see FHWA and/or state/specifying agency standards.

Gauge Conversions
10 Gauge [3.43 mm]
12 Gauge [2.67 mm]

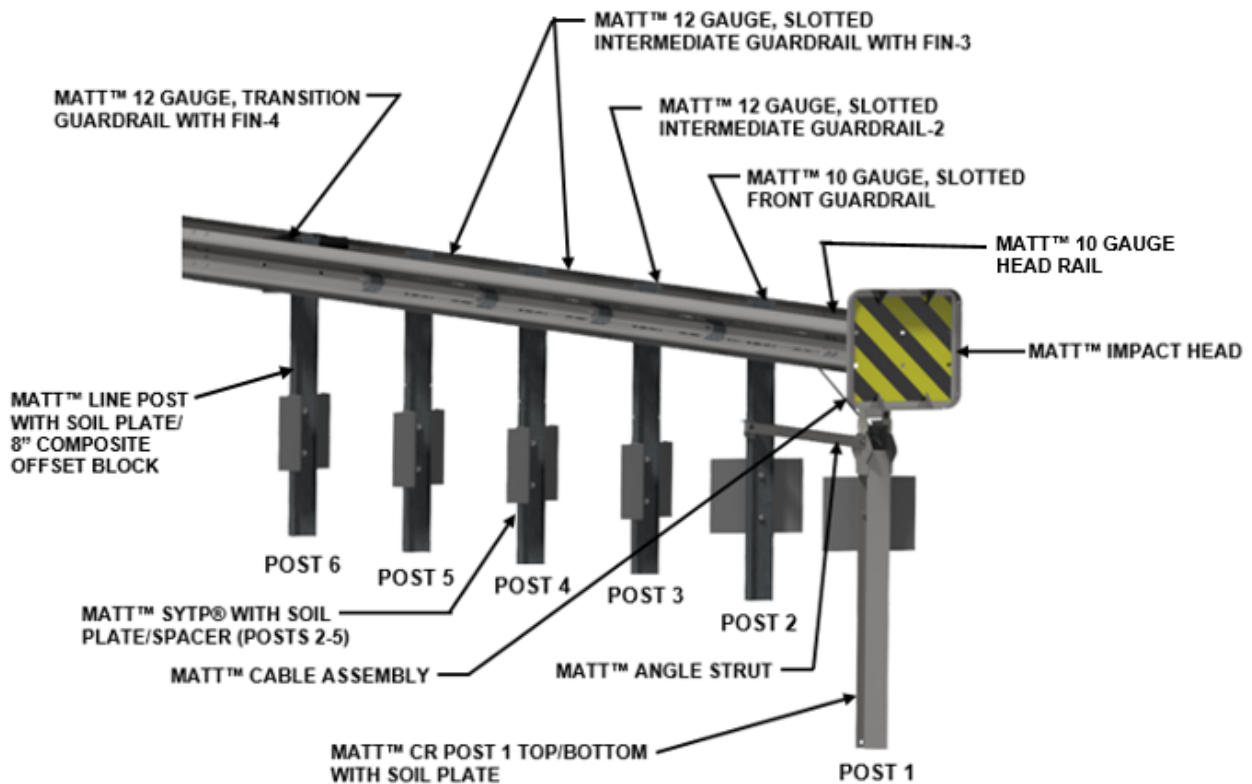

## MATT™

Reference Drawing: SS 6288

# **Recommended Tools**

## **Documentation**

- Manufacturer's MATT™ Product Description Assembly Manual (Current Version).
- MATT™ Drawing(s) SS 6288 (Current Version).
- MATT™ Transition Drawings:
  - SS 6287 (Current Version)
  - SS 6289 (Current Version)

## **Personal Protective Equipment**

- Eye Protection
- Work Gloves
- Safety-Toe Shoes
- Back Protection
- Hard Hat
- Reflective Vest
- Apron

## **Miscellaneous**

- Traffic Control Equipment and Plan per state/specifying agency standards and the MUTCD.
- SAE Combination Wrench Set
- Socket Set & Socket Wrench
- Hammer
- Chalk Line
- Tape Measure
- Marking Paint and Pen
- Straight Edge
- Level
- Plumb Line
- Post Pounder (commonly used for driving posts)
- Auger
- Soil Tamper
- 5/8" Alignment Tool (Drift Pin), used to help align panels
- Locking Pliers and/or Pipe Wrench
- Calibrated Torque Wrench (or other tool), capable of measuring 65 ft.-lb. [88 Nm] ± 3 ft-lb [± 4 Nm].

**Note: The provided list of tools is a general recommendation and should not be considered an extensive list. Depending on specific site conditions and the complexity of the assembly, the required tools may vary. Decisions as to what tools are needed to perform the job are entirely the responsibility of the state/specifying agency and the selected contractor performing the assembly of the system at the state/specifying agency's site.**



## Site Preparation

The MATT™ has a system length of 34'-4 1/2" [10.477 m] long and is a tangent, 31" [787 mm] (+1" -0") [+25 mm, -0 mm] high, double-sided, re-directive/gating and energy absorbing attenuator/end terminal available for use with various longitudinal highway barriers, in either unidirectional or bidirectional traffic applications.

It may be specified for use by the state/specifying agency in conjunction with strong post W-beam guardrail systems on the NHS or other roadway. The decision to specify the MATT™ for a particular project is the responsibility of the state/specifying agency design engineer who must ensure that the most appropriate end treatment has been selected for the specific site conditions.

The MATT™ is designed to be attached directly to double sided strong post W-beam guardrail systems that have been accepted under MASH or NCHRP Report 350 crash test criteria that utilize 8" [200 mm] offset blocks.



**IMPORTANT: The MATT™ must not be attached directly to a weak post W-beam guardrail system without an approved weak-post-to-strong-post transition plus a minimum of 12'-6" [3.810 m] strong post W-beam guardrail with 6'-3" [1.905 m] post spacing. The 12'-6" [3.810 m] strong post W-beam guardrail must be placed between the MATT™ and the weak-post- to-strong-post transition.**



**IMPORTANT: Under NO circumstances shall the rail within the MATT™ be curved, between Post 1 and Post 6. Ensure all MATT™ post spacings are 6'-3" [1.905 m] on center.**



**IMPORTANT: When used with rigid barriers, (i.e., concrete barrier, wall or bridge pier) a semi to rigid barrier transition will be required (see state/specifying agency standards).**



**IMPORTANT: Ensure the state/specifying agency standard transition is used when connecting the MATT™ to a system other than double sided, 31" [787 mm] high MGS with 8" [200 mm] offset blocks.**



**IMPORTANT: Ensure that the MATT™ application conforms to the AASHTO Roadside Design Guide, current edition to include appropriate grading details.**



**IMPORTANT: Valtir does not direct grading. Proper site grading must be accomplished before assembly of the MATT™ in accordance with local guidelines OR the AASHTO Roadside Design Guide (see Appendix A and B), whichever is more stringent. Failure to follow this warning could result in serious injury or death in the event of a vehicle impact with the system.**



**IMPORTANT: The Beginning Length of Need ("BLON") for the MATT™ was established during MASH Test 3-35 at Post 3, which is 12'-6" [3.810 m] from Post 1.**



**IMPORTANT: Only 8" [200 mm] composite offset blocks can be used at Post 6 and only the supplied special MATT™ spacers/double spacers at all other post locations.**



**MATT™ was tested to MASH-2nd Edition (2016), with 2020 Errata Test Level 3 criteria and may be used in Test Level 1, Test Level 2, and Test Level 3 applications – when installed at the full Test Level 3 system length of 34' 4-1/2" [10.477 m].**



**MATT™ can be aesthetically stained/treated, after Hot Dipped Galvanizing, with a reactive color treatment. The MATT™ may NOT be powder coated or painted.**

## **Post Placement**

The MATT™ posts are inserted into the soil using an auger or post pounding equipment for placement. If an auger is used, ensure diameter is large enough to allow for proper compaction of state/specifying agency approved fill material. All MATT™ posts must be assembled within established standard construction tolerances, including being reasonably plumb. Compaction for all posts must be within the state/specifying agency guidelines.



**Danger: It is the responsibility of the installer to ensure all above & below ground utilities as well as drainage structures are located, marked, and identified prior to using an auger or post pounding tool in accordance with state/specifying agency guidelines. Failure to follow this warning could result in serious injury or death.**

## **Rigid Pavement and Rock**

If rigid pavement (e.g. concrete or asphalt) of any thickness is encountered at post 6, follow the state/specifying agency guidance or policy in regards to standard guardrail installation methods for such conditions. IF a state/specifying agency does NOT have such guidance or policy, the MATT™ designer's recommendation is to ensure a proper "leave-out" area (the specified size of open space as defined in the AASHTO Roadside Design Guide) and/or per the state/specifying agency is provided around the posts and filled with the state/ specifying agency approved backfill material.

If solid rock is encountered at post locations 3-6, refer to the state/specifying agency guidelines and/or the AASHTO Roadside Design Guide for requirements for embedment depth into the rock and size of the hole. If solid rock is encountered at post locations 1-2, auger a hole in the rock large enough for full post embedment and proper compaction of approved fill material.

See pages 40-42 of this manual for alternate foundations, which could be applicable in solid rock applications.



### **Drilling Holes into rock**

Caution: It is the responsibility of the installer to consult Occupational Safety & Health Administration ("OSHA") silica respiratory standard 29 Code of Federal Regulation ("CFR") 1910.134 for debris removal and ensure compliance.

## **Inspect Shipment**

Carefully unpack and inspect all components for damage. Check the received parts against the packing list supplied with the system. If any parts are damaged, missing, or unspecified; do not attempt to assemble the system and contact Valtir immediately (p. 4).



**Warning: Use only Valtir parts that are specified by Valtir for use with the MATT™ for assembling, maintaining, or repairing the MATT™. Do not utilize or otherwise commingle parts from other systems even if those systems are other Valtir Systems.**



ID	MATT™ COMPONENTS/HARDWARE (PALLETIZED)	626884A	QTY
	MATT™ COMPONENTS/HARDWARE (UNPALLETIZED)	506288B	
A	MATT™ Impact Head	628342B	1
B	MATT™ 12 Gauge Transition Guardrail With Fin-4, 9'-4 1/2" [2.858 m]	628289A	2
C	MATT™ 12 Gauge, Slotted Intermediate Guardrail with Fin-3,6'-3" [1.905 m]	628337A	4
D	MATT™ 12 Gauge, Slotted Intermediate Guardrail-2, 6'-3" [1.905 m]	628274G	2
E	MATT™ 10 Gauge, Slotted Front Guardrail-1, 6'-3" [1.905 m]	628347G	2
F	MATT™ 10 Gauge Head Rail, 1'- 9 3/4" [552 mm]	628339A	2
G	MATT™ Single Spacer	628281A	6
H	MATT™ Double Spacer	628280A	2
I	MATT™ Head Tube	628275A	1
K	MATT™ CR Post 1 Top	628285A	1
L	MATT™ CR Post 1 Bottom – used with soil plate	628276A	1
M	MATT™ SYTP® 6'-0" [1.829 m] – used with soil plate	628271G	4
N	MATT™ System Line Post 6'-0" [1.829 m] – used with soil plate	628270G	1
O	MATT™ Angle Strut	628279G	1
P	MATT™ Cable Assembly 3/4" x 7'-5" [19 mm x 2.260 m]	119506G	1
KK	8" [200 mm] Composite Offset Block (wood is not allowed)	VARIOUS	2
MM	MATT™ Soil PL, 1/4" x 18" x 24" [6 mm x 457 mm x 610 mm] for Posts 1-2	628273G	2
NN	MATT™ Soil Plate W-Shaped (Multi-Directional) for Posts 3-6	628269G	4
	<b>MATT™ HARDWARE BUCKET (MANUAL INCLUDED)</b>	<b>626883A</b>	<b>1</b>
	<b>MATT™ Hardware Bag 1 – To Include</b>	<b>628312B</b>	<b>1</b>
T	5/8" x 1.75" [16 mm x 44 mm] Hex Bolt A325/ Grade 5	3391G	2
BB	5/8" [16 mm] GR Hex Nut – Double Recessed	3340G	12
OO	5/8" x 3.50" [16 mm x 90 mm] Hex Bolt Grade 5 (A325)	113660G	10
	<b>MATT™ Spacer Block &amp; Post 1 Hardware Bag 2 – To Include</b>	<b>628313B</b>	<b>1</b>
S	5/16" x 1.75" [8 mm x 44 mm] Hex Bolt A325 / Grade 5	4211G	2
V	5/8" x 2" [16 mm x 90 mm] Hex Bolt (A307, Fully Threaded)	3403G	6
Y	5/16" [8 mm] Hex Nut	3245G	2
AA	5/8" [16 mm] Round Flat Washer	4372G	6
BB	5/8" [16 mm] GR Hex Nut – Double Recessed	3340G	6
FF	1/2" x 1.5" [13 mm x 38 mm] Hex Bolt (A307)	113457G	4
GG	1/2" [13 mm] Flat Washer	118009G	8
HH	1/2" [13 mm] Hex Nut	115939G	4
JJ	5/16" [8 mm] Round Flat Washer	3240G	2
	<b>MATT™ Post 6 and Splice Hardware Bag – To Include</b>	<b>628314B</b>	<b>1</b>
U	5/8" x 2" [16 mm x 51 mm] GR Shoulder Bolt A325 / Grade 5	3360G	16
BB	5/8" [16 mm] GR Hex Nut – Double Recessed	3340G	18
TT	5/8" x 10" [16 mm x 254 mm] GR Post Bolt (A307)	3500G	2
	<b>MATT™ Special Bolts, Washers &amp; HS Nuts Bag 4 – To Include</b>	<b>628315B</b>	<b>1</b>
W	5/8" x 2" [16 mm x 51 mm] GR Shoulder Bolt A325 / Grade 5	118614G	62
Z	5/8" [16 mm] Heavy Hex Nut A563 (Typically Blue or Green)	3361G	62
CC	1" [25 mm] Round Flat Washer	4902G	8
EE	5/8" x 1/4" Thick [16 mm x 6 mm thick] Flat Washer	118615G	62
	<b>MATT™ Anchor and Strut Bag 5 – To Include</b>	<b>628316B</b>	<b>1</b>
T	5/8" x 1.75" [16 mm x 44 mm] Hex Bolt A325 / Grade 5	3391G	4
Z	5/8" [16 mm] Heavy Hex Nut A563 (Typically Blue or Green)	3361G	4
AA	5/8" [16 mm] Round Flat Washer	4372G	2
CC	1" [25 mm] Round Flat Washer	4902G	2
DD	1" [25 mm] Hex Nut	3910G	2
	<b>Loose Materials in MATT™ Bucket – To Include:</b>		
J	MATT™ Backing Plate	628338G	8
Q	Cable Anchor Bracket Angle	33909G	1
R	MATT™ Strut Adapter Plate	628348G	1

## **MATT™ Components/Hardware**

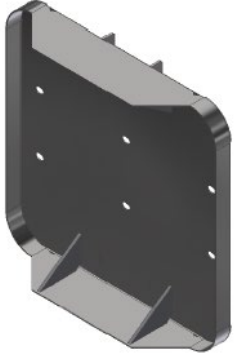
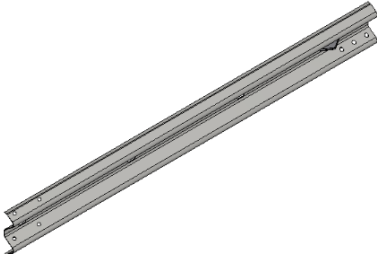
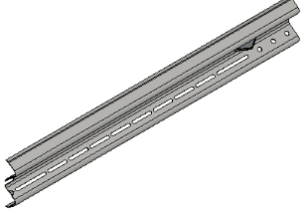

Below is a pictorial depiction of the components/hardware for MATT™. Please see the Valtir drawings and page 10 of this manual for specific lists of components/hardware and quantities required for MATT™ selected to be assembled.

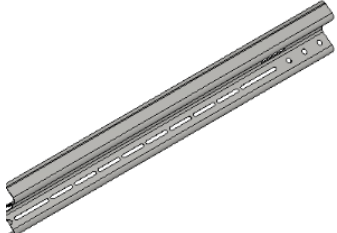
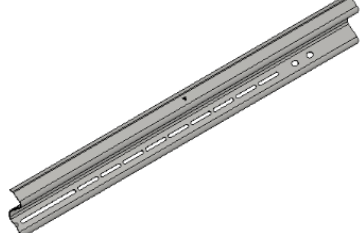
**Note:** The following components/hardware are not shown to scale.

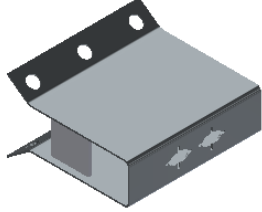
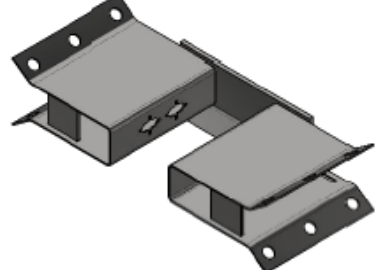
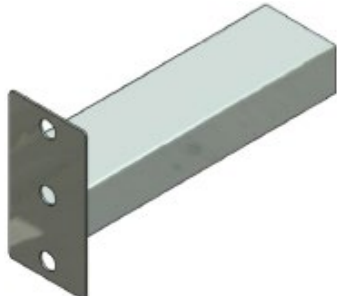

ID: A	PN: 628342B	ID: B	PN: 628289A	ID: C	PN: 628337A
					
MATT™ Impact Head		MATT™ 12 Gauge, Transition, Guardrail with Fin-4, 9'-4 1/2"		MATT™ 12 Gauge, Slotted Intermediate Guardrail with Fin-3, 6'-3"	

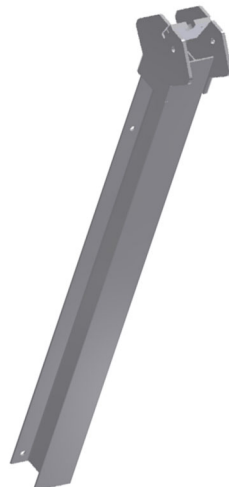

ID: D	PN: 628274G	ID: E	PN: 628347G	ID: F	PN: 628339A
					
MATT™ 12 Gauge, Slotted Intermediate Guardrail-2, 6'-3"		MATT™ 10 Gauge, Slotted Front, Guardrail-1, 6'-3"		MATT™ 10 Gauge, Head Rail, 1'-9 3/4"	

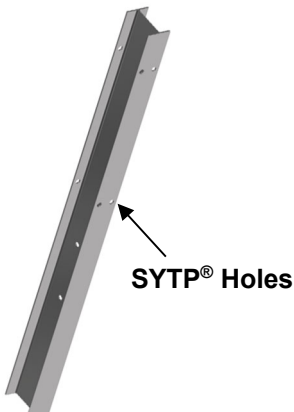
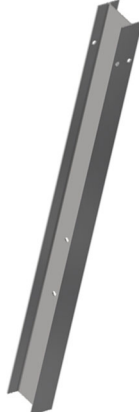
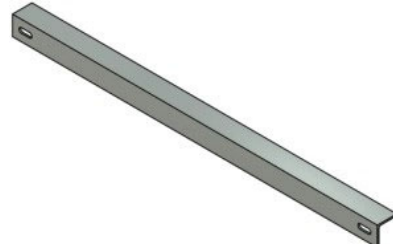

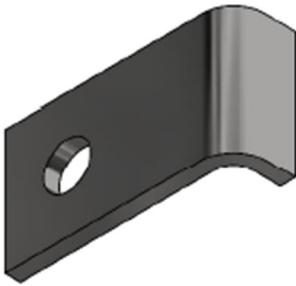
ID: G	PN: 628281A	ID: H	PN: 628280A	ID: I	PN: 628275A
					
MATT™ Single Spacer		MATT™ Double Spacer		MATT™ Head Tube	

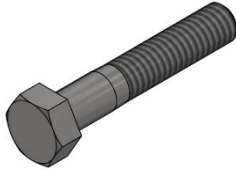
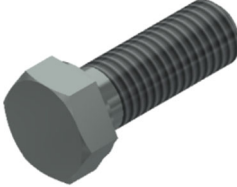

ID: J	PN: 628338G	ID: K	PN: 628285A	ID: L	PN: 628276A
					
MATT™ Backing Plate		MATT™ CR Post 1 Top		MATT™ CR Post 1 Bottom	

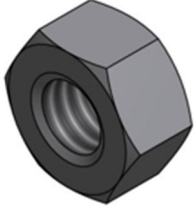

ID: M	PN: 628271G	ID: N	PN: 628270G	ID: O	PN: 628279G
					
MATT™ SYTP® 6'-0"		MATT™ Line Post 6'-0"		MATT™ Angle Strut	

ID: P	PN: 119506G	ID: Q	PN: 33909G	ID: R	PN: 628348G
					
MATT™ Cable Assembly 3/4" x 7'-5"		Cable Anchor Bracket Angle		MATT™ Strut Adapter Plate	

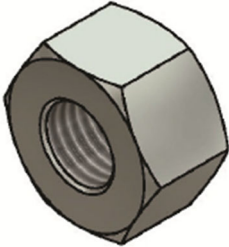
ID: S	PN: 4211G	ID: T	PN: 3391G	ID: U	PN: 3360G
					
5/16" x 1.75" Hex Bolt [8 mm x 44 mm]		5/8" x 1.75" Hex Bolt (A325) [16 mm x 44 mm]		5/8" x 1.25" GR Bolt [16 mm x 31 mm]	

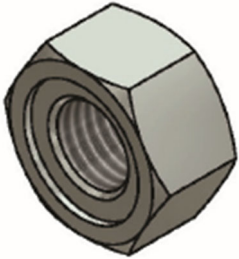
ID: V	PN: 3403G	ID: W	PN: 118614G	ID: Y	PN: 3245G
					
5/8" x 2" Hex Bolt A307 [16 mm x 51 mm]		5/8" x 2" GR Bolt (Grade 5) [16 mm x 51 mm]		5/16" Hex Nut [8 mm]	

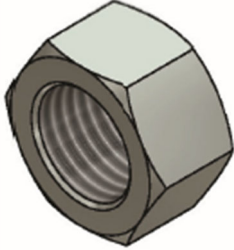

ID: Z	PN: 3361G	ID: AA	PN: 4372G	ID: BB	PN: 3340G
					
5/8" Heavy Hex Nut A563 DH [16 mm]		5/8" Round Washer [16 mm]		5/8" GR Hex Nut [16 mm]	

ID: CC	PN: 4902G	ID: DD	PN: 3910G	ID: EE	PN: 118615G
					
1" Flat Washer [25 mm]		1" Hex Nut [25 mm]		5/8" Flat Washer (1/4" thick) [16 mm] [6 mm thick]	

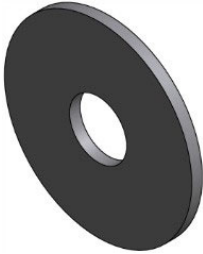
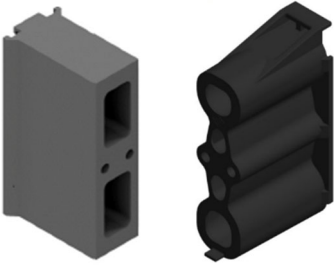
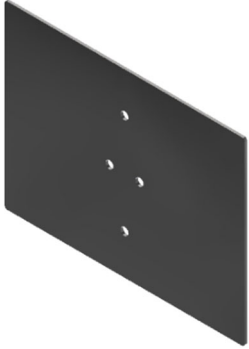
ID: FF	PN: 113457G	ID: GG	PN: 118009G	ID: HH	PN: 115939G
					
1/2" x 1.50" Hex Bolt [13 mm x 38 mm]		1/2" Flat Washer [13 mm]		1/2" Hex Nut [13 mm]	

ID: JJ	PN: 3240G	ID: KK	PN: Various	ID: MM	PN: 628273G
					
5/16" Flat Washer [8 mm]		8" [200 mm] Composite Offset Block		MATT™ Soil Plate Posts 1 & 2	

ID: NN	PN: 628269G	ID: OO	PN: 113660G	ID: TT	PN: 3500G
					
MATT™ Soil Plate W-Shaped Posts 3-6		5/8" x 3.50" Hex Bolt Grade 5 (A325) [16 mm x 90 mm]		5/8" x 10" GR Bolt A307 [16 mm x 254 mm]	

ID: YY	PN: 105379B	ID: ZZ	PN: 105380B	ID:	
					
25" x 25" [625 mm x 625 mm] Yellow/Black Reflector (Right/Left)		25" x 25" [625 mm x 625 mm] Yellow/Black Reflector (Gore)			

## Assembly Steps



To ensure an accurate assembly of the MATT™ Terminal, it is recommended that steps be completed in order; however, some contractors have preassembled some steps. **ALL STEPS MUST BE COMPLETED.**



Below ground portions in some assembly steps are not shown for clarity. It is acceptable to field weld the soil plates to the posts in Steps 2A-2D. After welding, wire brush the weld to remove loose slag, then apply a zinc rich paint, consistent with ASTM A780 or as instructed by specifying agency.



See Step 16 for bolt/nuts combinations that must be torqued to 65 ft-lb [88 Nm] (+/- 3 ft-lb) [+/- 4 Nm].



After the system is fully assembled, for Steps 5A and 5B, tighten the double/single spacers to a snug position with a minimum of two (2) bolt threads protruding beyond the nut for all hardware that was assembled loosely, ensuring bolt is seated for these steps.

## MATT™ Guardrail Identification/Orientation

Note: The Rail Panel Splice Bolt Holes/Fin are **ALWAYS** located Upstream



E

MATT™ 10 Gauge, Slotted Front Guardrail Without Fin-1, 6'-3" [1.905 m] PN 628347G



D

MATT™ 12 Gauge, Slotted Intermediate Guardrail Without Fin-2, 6'-3" [1.905 m] PN 628274G



C

MATT™ 12 Gauge, Slotted Intermediate Guardrail WITH Fin-3, 6'-3" [1.905 m] PN 628337A



B

MATT™ 12 Gauge, Transition Guardrail WITH Fin-4, 9'-4 1/2" [2.858 m] PN 628289A





# STEP 1

## MATT™ Post Layout (Posts 1-6)

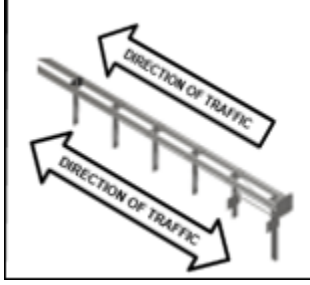
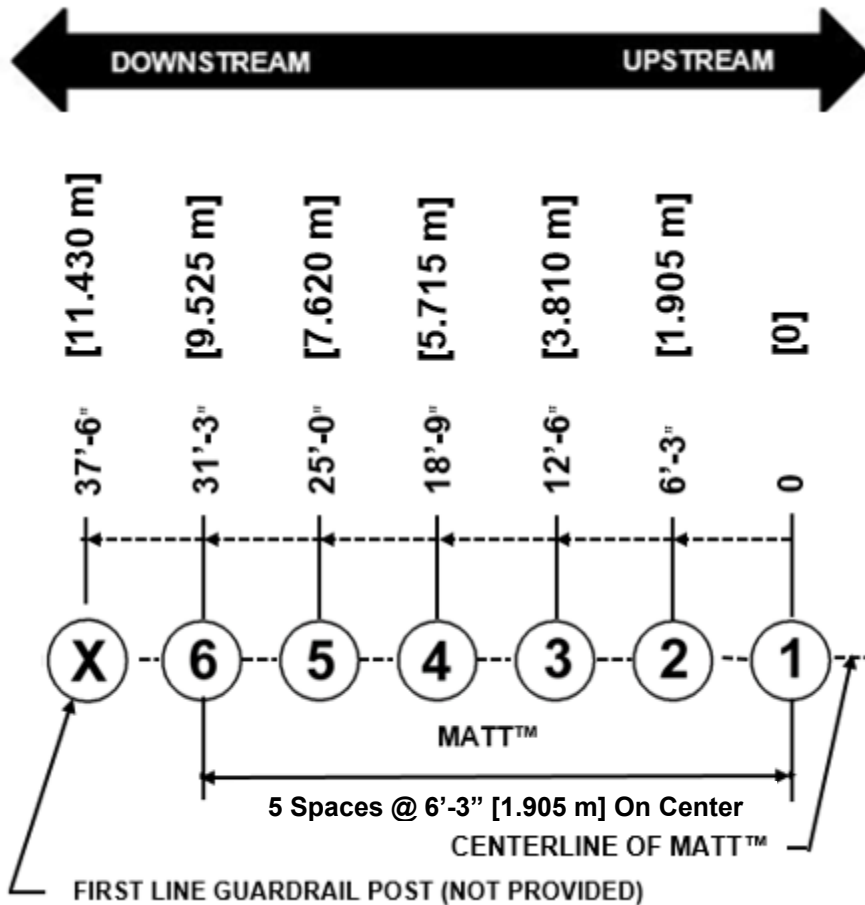

### PARTS

### INSTRUCTIONS

Reference: SS-6288

1. Layout the post locations as shown above.
2. Layout and placement of the posts are critical to the assembly of the MATT™.
3. All MATT™ posts are spaced at 6'-3" [1.905 m] on center and installed reasonably plumb.
4. MATT™ Posts 2-6 height is approximately 32" [813 mm] above finished grade.
5. MATT™ Post 1 is approximately 4" [100 mm] above finished grade.

### WARNINGS

Use only Valtir parts that are specified herein for the MATT™ for assembling, maintaining, or repairing the MATT™. Do not utilize or otherwise commingle parts from other systems even if those systems are Valtir systems.



Ensure proper site grading in accordance with the state/specifying agency guidelines and/or the AASHTO Roadside Design Guide, whichever is more stringent. Failure to follow this warning could result in serious injury or death in the event of a vehicle impact with the system.

# STEP 2A

## MATT™ CR Post 1 Bottom With Soil Plate Assembly

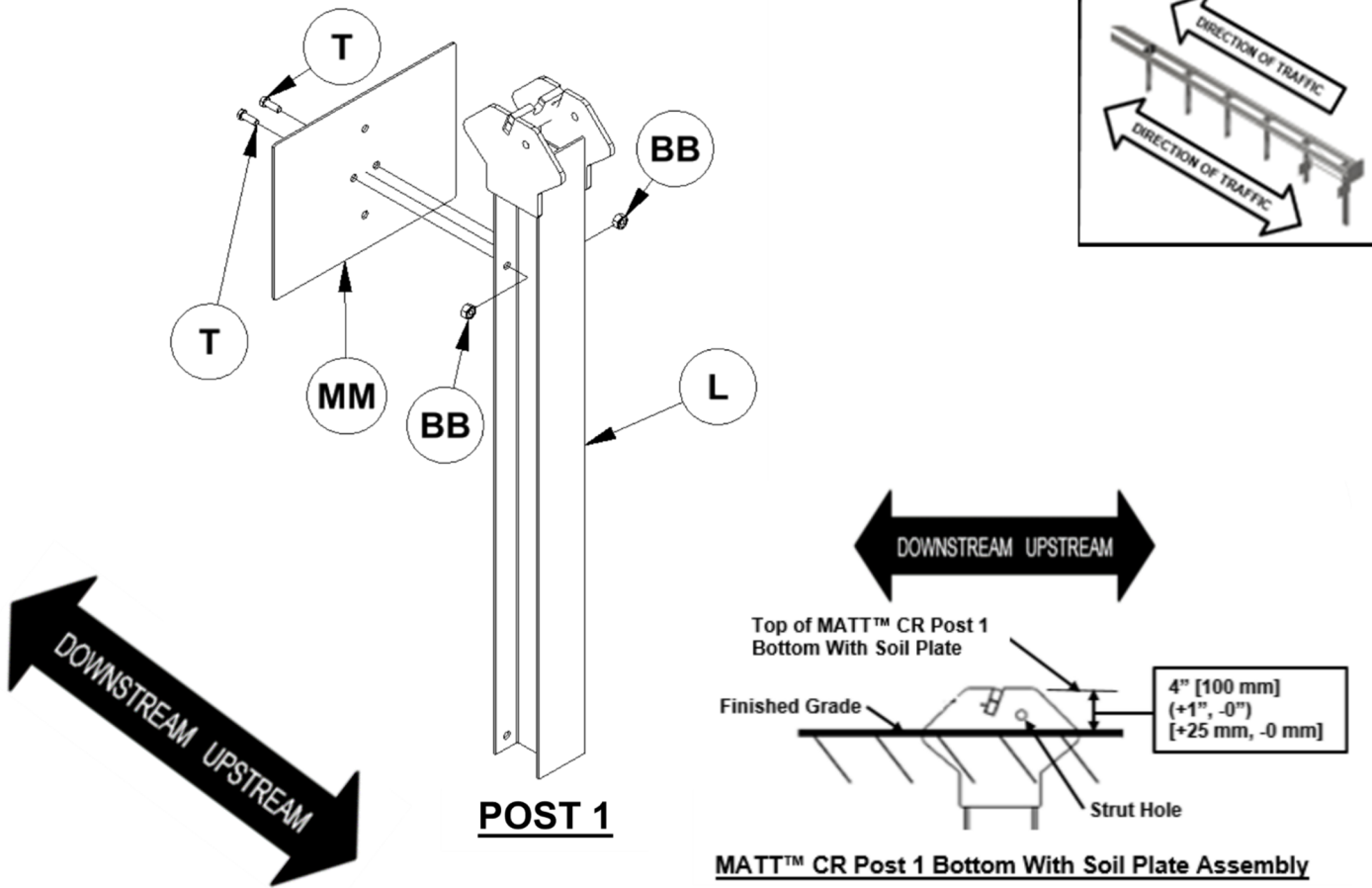



MATT™ CR Post 1 Bottom With Soil Plate Assembly

PARTS			INSTRUCTIONS
L	628276A	1 EA	<b>Reference: SS-6288</b> 1. Assemble the MATT™ Soil Plate (Part MM) to the <b>downstream</b> side of the 6'-0" [1.829 m] MATT™ CR Post 1 Bottom (Part L) as shown above using specified hardware (Parts T, BB). 2. Tighten all threaded hardware to a snug position with a minimum of two (2) bolt threads protruding beyond the nut 3. Assemble the 6'-0" [1.829 m] MATT™ CR Post 1 Bottom With Soil Plate as shown above at location established in Step 1. 4. Ensure that the MATT™ Strut Hole is assembled on the <b>upstream</b> side of the post. 5. Ensure the top of the MATT™ CR Post 1 Bottom is 4" [100 mm] (+1", -0") [+25 mm, -0 mm] above finished grade.
T	3391G	2 EA	
BB	3340G	2 EA	
MM	628273G	1 EA	
Use only Valtir parts that are specified herein for the MATT™ for assembling, maintaining, or repairing the MATT™. <u>Do not utilize or otherwise commingle parts from other systems even if those systems are Valtir systems.</u>			<b>WARNINGS</b>  Ensure the MATT™ Soil Plate is on the <b>downstream</b> side of the CR Post 1 Bottom and Strut Hole is <b>upstream</b> . Ensure threaded hardware is tightened to a snug position with a minimum of two (2) bolt threads protruding beyond the nut. Ensure the top of the MATT™ CR Post 1 Bottom is 4" [100 mm] (+1", -0") [+25 mm, -0 mm] above finished grade. Failure to follow these warnings could result in serious injury or death in the event of a vehicle impact with the system.

# STEP 2B

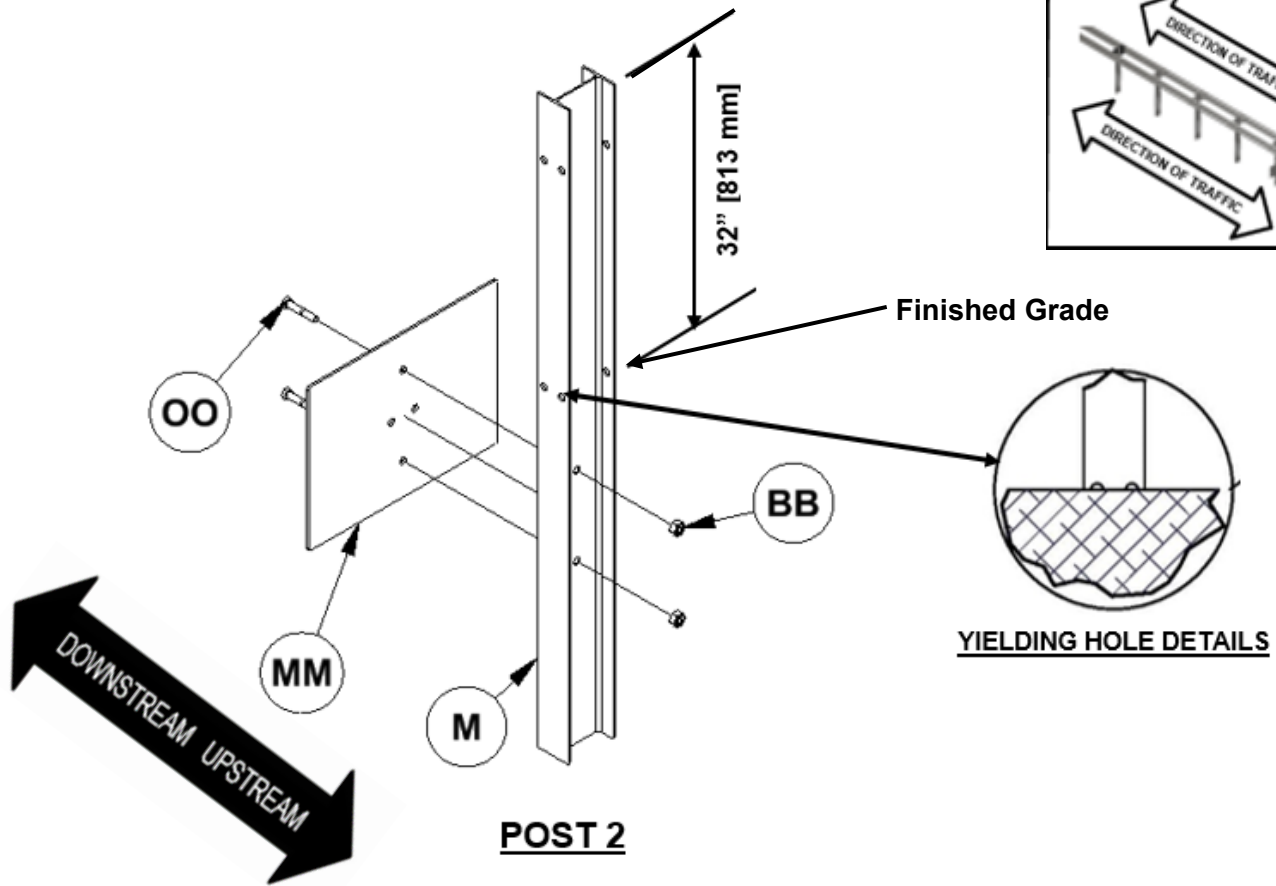
## MATT™ SYTP® With Soil Plate Assembly Post 2



PARTS			INSTRUCTIONS
M	628271G	1 EA	<b>Reference: SS-6288</b> 1. Assemble the MATT™ Soil Plate (Part MM) to the <b>downstream</b> side of the 6'-0" [1.829 m] MATT™ SYTP® (Part M) as shown above using specified hardware (Parts BB, OO). 2. Tighten all threaded hardware to a snug position with a minimum of two (2) bolt threads protruding beyond the nut. 3. Assemble the 6'-0" [1.829 m] MATT™ SYTP® with Soil Plate on the <b>downstream</b> side of the post as shown above for Post 2 at location established in Step 1. 4. Ensure the center of the SYTP® Holes are approximately at finished grade (+1", -0") [+25 mm, -0 mm].
BB	3340G	2 EA	
MM	628273G	1 EA	
OO	113660G	2 EA	
Use only Valtir parts that are specified herein for the MATT™ for assembling, maintaining, or repairing the MATT™. <u>Do not utilize or otherwise commingle parts from other systems even if those systems are Valtir systems.</u>			<b>WARNINGS</b>  Ensure the MATT™ Soil Plate is on the <b>downstream</b> side of the MATT™ SYTP®. Ensure the center of the SYTP® Holes are approximately at finished grade (+1", -0") [+25 mm, -0 mm]. Ensure the Post spacing is as established in Step 1. Failure to follow these warnings could result in serious injury or death in the event of a vehicle impact with the system.

# STEP 2C

## MATT™ SYTP® With Soil Plate W-Shaped Assembly for Posts 3 to 5

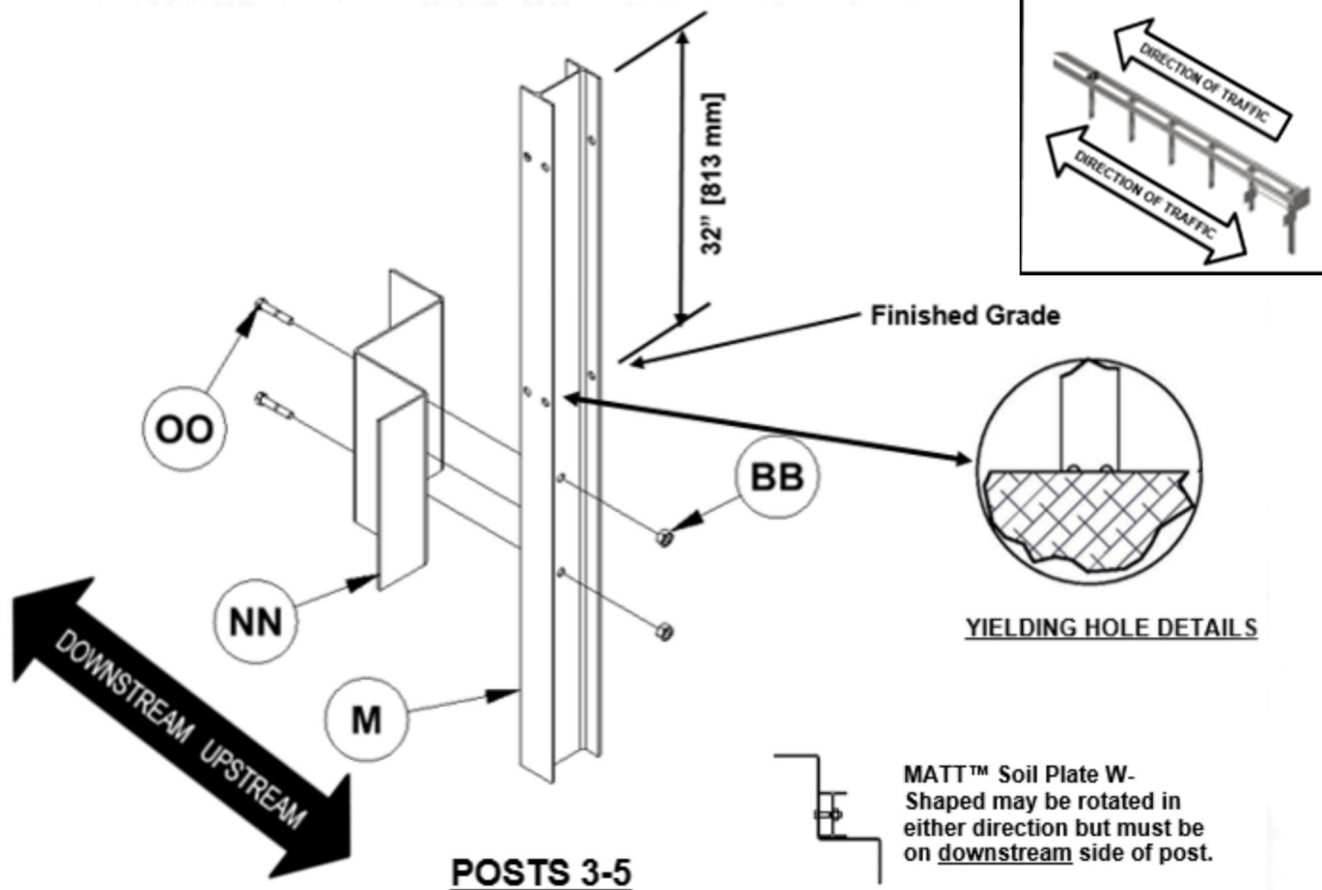

PARTS			INSTRUCTIONS
M	628271G	3 EA	<b>Reference: SS-6288</b> 1. Assemble the MATT™ Soil Plate W-Shaped (Part NN) to the <b>downstream</b> side of the 6'-0" [1.829 m] MATT™ SYTP® (Part M) as shown above using specified hardware (Parts BB, OO). 2. Tighten all threaded hardware to a snug position with a minimum of two (2) bolt threads protruding beyond the nut. 3. Assemble the 6'-0" [1.829 m] MATT™ SYTP® with Soil Plate W-Shaped on the <b>downstream</b> side of the post as shown above for Post 3-5 at location established in Step 1. 4. Ensure the center of the SYTP® Holes are approximately at finished grade (+1", -0") [+25 mm, -0 mm].
BB	3340G	6 EA	
NN	628269G	3 EA	
OO	113660G	6 EA	
Use only Valtir parts that are specified herein for the MATT™ for assembling, maintaining, or repairing the MATT™. <u>Do not utilize or otherwise commingle parts from other systems even if those systems are Valtir systems.</u>			WARNINGS
			 Ensure the MATT™ Soil Plate W-Shaped is on the <b>downstream</b> side of MATT™ SYTP® 3-5. Ensure the center of the SYTP® Holes are approximately at finished grade (+1", -0") [+25 mm, -0 mm]. Ensure the Post spacing is as established in Step 1. Ensure threaded hardware is tightened to a snug position with a minimum of two (2) bolt threads protruding beyond the nut. Failure to follow these warnings could result in serious injury or death in the event of a vehicle impact with the system.

# STEP 2D

## MATT™ Line Post w/ Soil Plate W-Shaped Assembly for Post 6

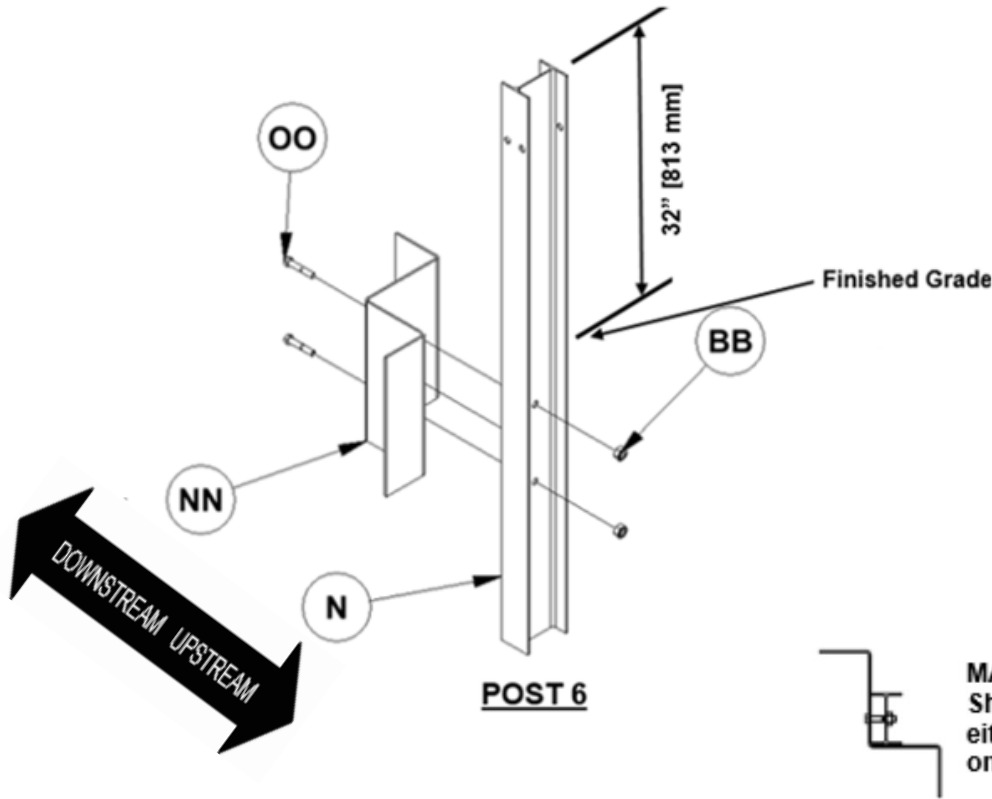

MATT™ Soil Plate W-Shaped may be rotated in either direction but must be on downstream side of post.

PARTS			INSTRUCTIONS
N	628270G	1 EA	<b>Reference: SS-6288</b> 1. Assemble the MATT™ Soil Plate W-Shape (Part NN) to the <u>downstream</u> side of the 6'-0" [1.829 m] MATT™ System Line Post 6 (Part N) as shown above using specified hardware (Parts BB, OO). 2. Tighten all threaded hardware to a snug position with a minimum of two (2) bolt threads protruding beyond the nut. 3. Assemble the 6'-0" [1.829 m] MATT™ System Line Post with Soil Plate W-Shaped on the <u>downstream</u> side of the post 32" [813 mm] (+1", -0") [+25 mm, -0 mm] from finished grade as shown above for Post 6 at location established in Step 1.
BB	3340G	2 EA	
NN	628269G	1 EA	
OO	113660G	2 EA	
Use only Valtir parts that are specified herein for the MATT™ for assembling, maintaining, or repairing the MATT™. Do not utilize or otherwise commingle parts from other systems even if those systems are Valtir systems.			<b>WARNINGS</b>  Ensure the MATT™ Soil Plate W-Shape is on the <u>downstream</u> side of MATT™ System Line Post 6. Ensure the Post spacing is as established in Step 1. Ensure threaded hardware is tightened to a snug position with a minimum of two (2) bolt threads protruding beyond the nut. Failure to follow these warnings could result in serious injury or death in the event of a vehicle impact with the system.

# STEP 3

## MATT™ ANGLE STRUT ASSEMBLY

Place the MATT™ Strut Adapter Plate (on Post 2) and MATT™ Angle Strut on the side of Posts 1 & 2 OPPOSITE from the closest traffic, when assembled in a Median or Roadside application. When assembled in a Gore application, it is acceptable to place them on either side of the post.

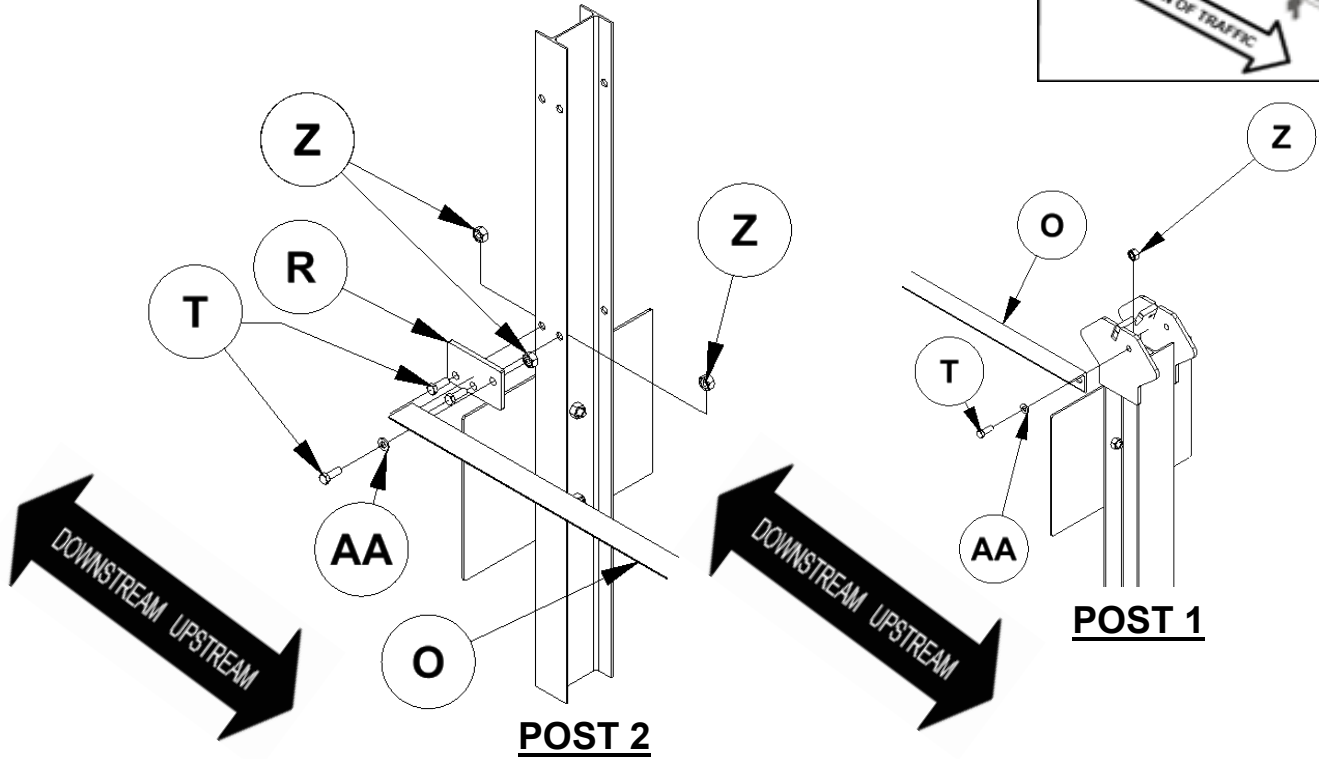
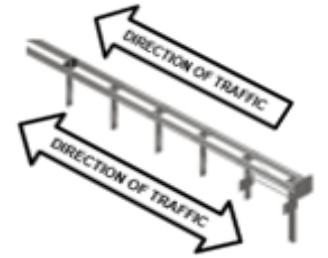

PARTS			INSTRUCTIONS
O	628279G	1 EA	<b>Reference: SS-6288</b> 1. Assemble the MATT™ Strut Adapter Plate (Part R) to Post 2 as shown above using specified hardware (Parts T, Z). 2. Assemble the MATT™ Angle Strut (Part O) with the “toe” of the vertical leg down and fasten to Posts 1 and the MATT™ Adapter Plate at Post 2, using shown hardware (Parts T, Z, AA) 3. Tighten all threaded hardware to a snug position with a minimum of two (2) bolt threads protruding beyond the nut.
R	628348G	1 EA	
T	3391G	4 EA	
Z	3361G	4 EA	
AA	4372G	2 EA	
			WARNINGS
Use only Valtir parts that are specified herein for the MATT™ for assembling, maintaining, or repairing the MATT™. <u>Do not utilize or otherwise commingle parts from other systems even if those systems are Valtir systems.</u>			 Ensure the flat washer is between the bolt head and the strut at Post 1 and 2. Ensure the “toe” of the vertical leg of the MATT™ Angle Strut is positioned down. Ensure threaded hardware is tightened to a snug position with a minimum of two (2) bolt threads protruding beyond the nut. Failure to follow these warnings could result in serious injury or death in the event of a vehicle impact with the system.

# STEP 4

## MATT™ CR Post 1 Top Assembly

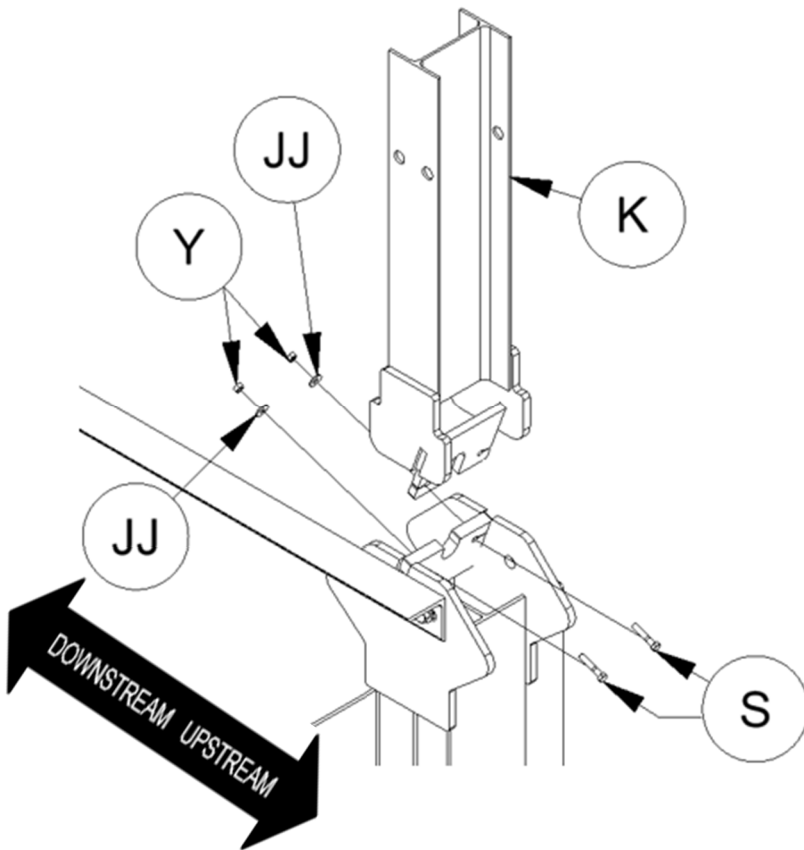

**POST 1**

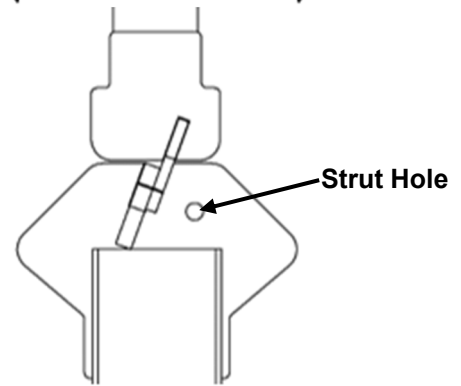
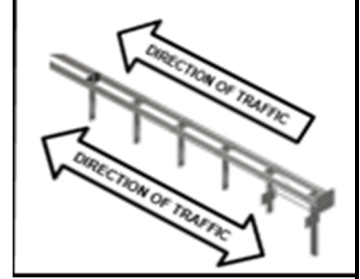

**MATT™ CR POST 1 TOP ORIENTATION DETAIL**

PARTS			INSTRUCTIONS
K	628285A	1 EA	<b>Reference: SS-6288</b> 1. Assemble the MATT™ CR Post 1 Top (Part K) to the MATT™ CR Post 1 Bottom as shown in the “MATT™ CR POST 1 TOP ORIENTATION DETAIL” using specified hardware (Parts S, JJ, Y). 2. Tighten all threaded hardware to a snug position with a minimum of two (2) bolt threads protruding beyond the nut.
S	4211G	2 EA	
Y	3245G	2 EA	
JJ	3240G	2 EA	
Use only Valtir parts that are specified herein for the MATT™ for assembling, maintaining, or repairing the MATT™. Do not utilize or otherwise commingle parts from other systems even if those systems are Valtir systems.			<h3>WARNINGS</h3>  Ensure the MATT™ CR Post 1 Top is oriented according to the detail above. Ensure the Strut Hole in the MATT™ CR Post 1 Bottom was installed <b>upstream</b> . See Step 2A Failure to follow this warning could result in serious injury or death in the event of a vehicle impact with the system.

# STEP 5A

## MATT™ Double Spacer Assembly Post 1 and 2

Assemble all hardware loosely ensuring bolt is seated for this step.

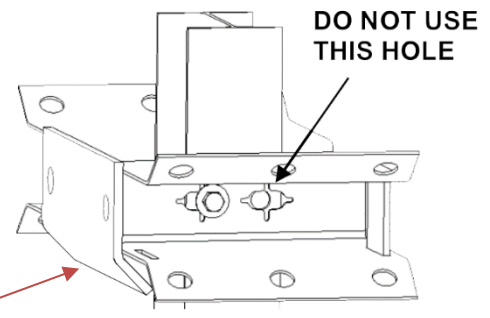
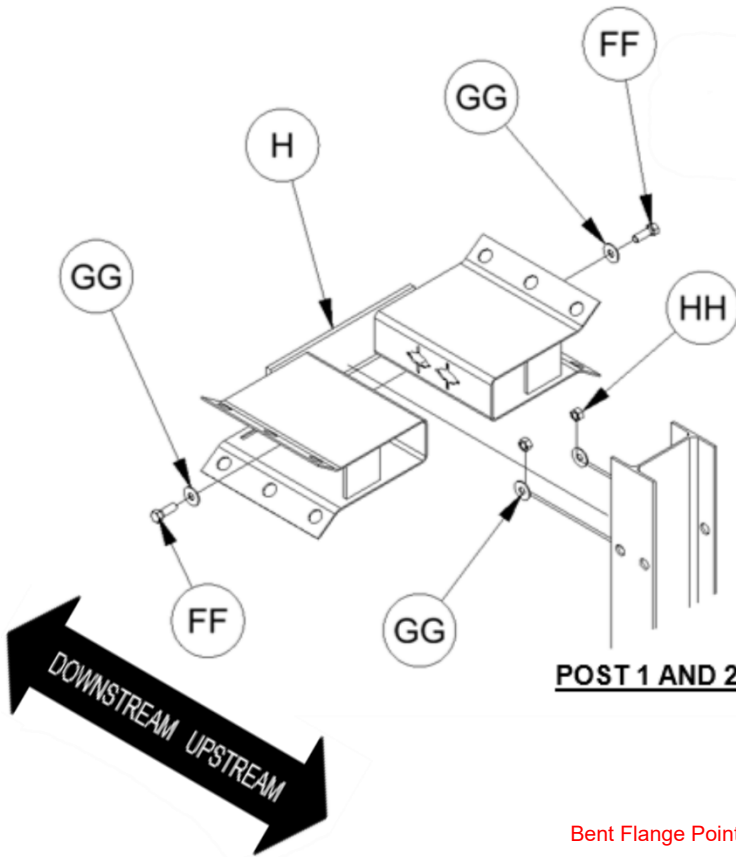
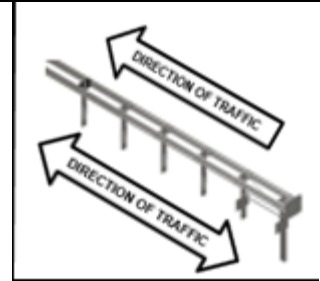

Orientation of the MATT™ Double Spacer Detail

PARTS			INSTRUCTIONS
H	628280A	2 EA	<b>Reference: SS-6288</b> 1. Assemble the MATT™ Double Spacer (Part H) to the MATT™ SYTP® (Post 2) and MATT™ CR Post 1 as shown above with the <b><u>Bent Flange Pointed Downward</u></b> using specified hardware (Parts FF, GG, HH). 2. Ensure the <b><u>downstream</u></b> slotted hole in the MATT™ Double Spacer is bolted to the MATT™ CR Post 1 and MATT™ SYTP® with Soil Plate (Post 2) using the <b><u>downstream</u></b> hole in the post. 3. Assemble all hardware loosely ensuring bolt is seated for this step.
FF	113457G	8 EA	
GG	118009G	4 EA	
HH	115939G	4 EA	
Use only Valtir parts that are specified herein for the MATT™ for assembling, maintaining, or repairing the MATT™. <u>Do not utilize or otherwise commingle parts from other systems even if those systems are Valtir systems.</u>			WARNINGS
			 Ensure the <b><u>downstream</u></b> slotted hole in the MATT™ Double Spacer is bolted to the MATT™ CR Post 1 and MATT™ SYTP® with Soil Plate (Post 2) using the <b><u>downstream</u></b> hole in the post. Ensure the MATT™ Double Spacer is orientated correctly with the <b><u>Bent Flanged Pointed Downward</u></b> for Posts 1 and 2. Failure to follow these warnings could result in serious injury or death in the event of a vehicle impact with the system.



# STEP 5B

## MATT™ Single Spacer Assembly Posts 3-5

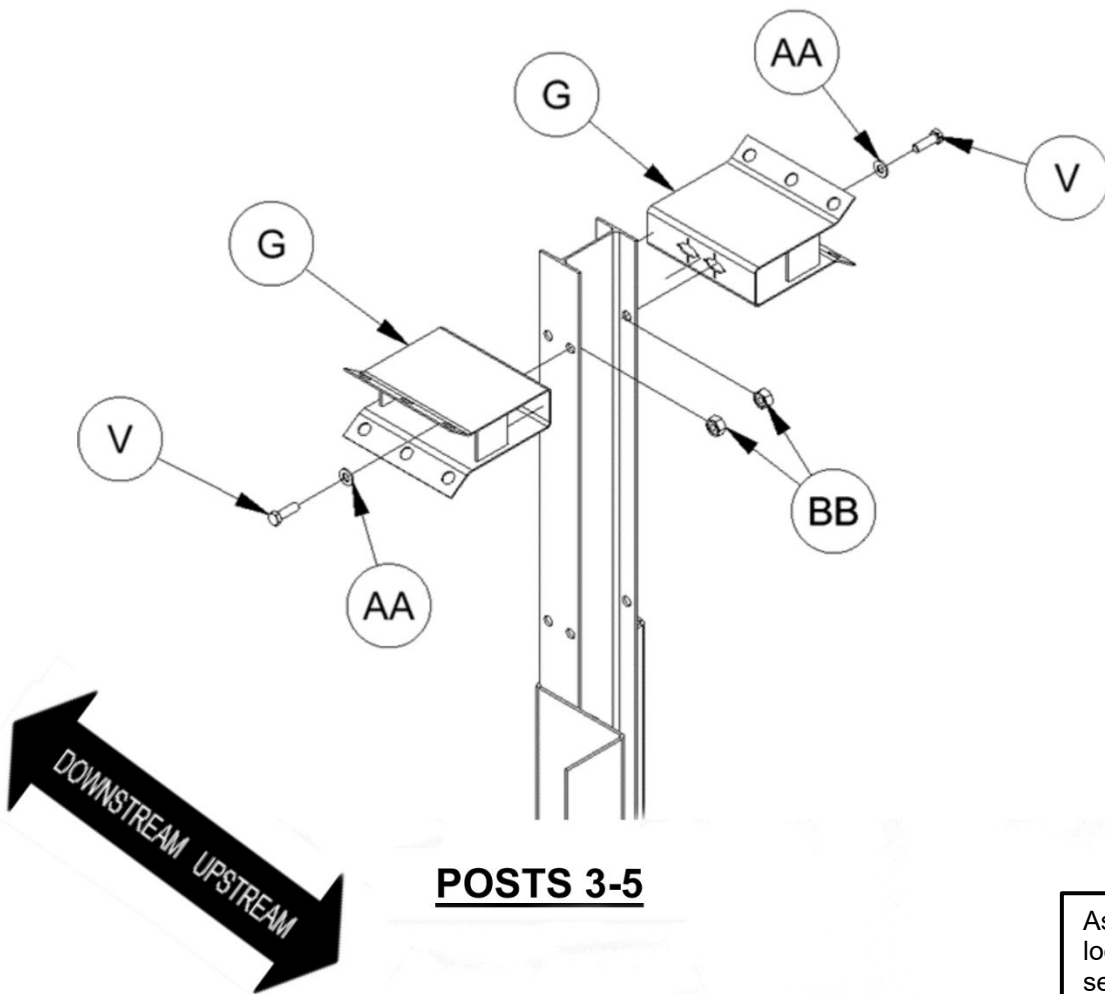

Assemble all hardware loosely ensuring bolt is seated for this step.

PARTS			INSTRUCTIONS
G	628281A	6 EA	<b>Reference: SS-6288</b> 1. Assemble the MATT™ hardware (Parts V, AA, BB). 2. Ensure the <b>upstream</b> slotted hole in the MATT™ Single Spacer is bolted to the MATT™ SYTP® with Soil Plate using the <b>upstream</b> hole in the post. 3. Ensure all hardware is assembled loosely ensuring bolt is seated for this step.
V	3403G	6 EA	
AA	4372G	6 EA	
BB	3340G	6 EA	
			WARNINGS
Use only Valtir parts that are specified herein for the MATT™ for assembling, maintaining, or repairing the MATT™. Do not utilize or otherwise commingle parts from other systems even if those systems are Valtir systems.			 Ensure the <b>upstream</b> slotted hole in the MATT™ Single Spacer is bolted to the MATT™ SYTP® with Soil Plate using the <b>upstream</b> hole in the post. Failure to follow this warning could result in serious injury or death in the event of a vehicle impact with the system.

# STEP 6

## MATT™ 12 Gauge Transition Guardrail with Fin-4, 9'-4 1/2" [2.858 m]

**Note:** The assembly shown for one side of the post is required for both sides of the post.

**Note:** At post location **6 only**, lap the MATT™ 12 Gauge Transition Guardrails with Fin-4 to the line guardrail system in the direction of the adjacent traffic. Position the fins upstream.

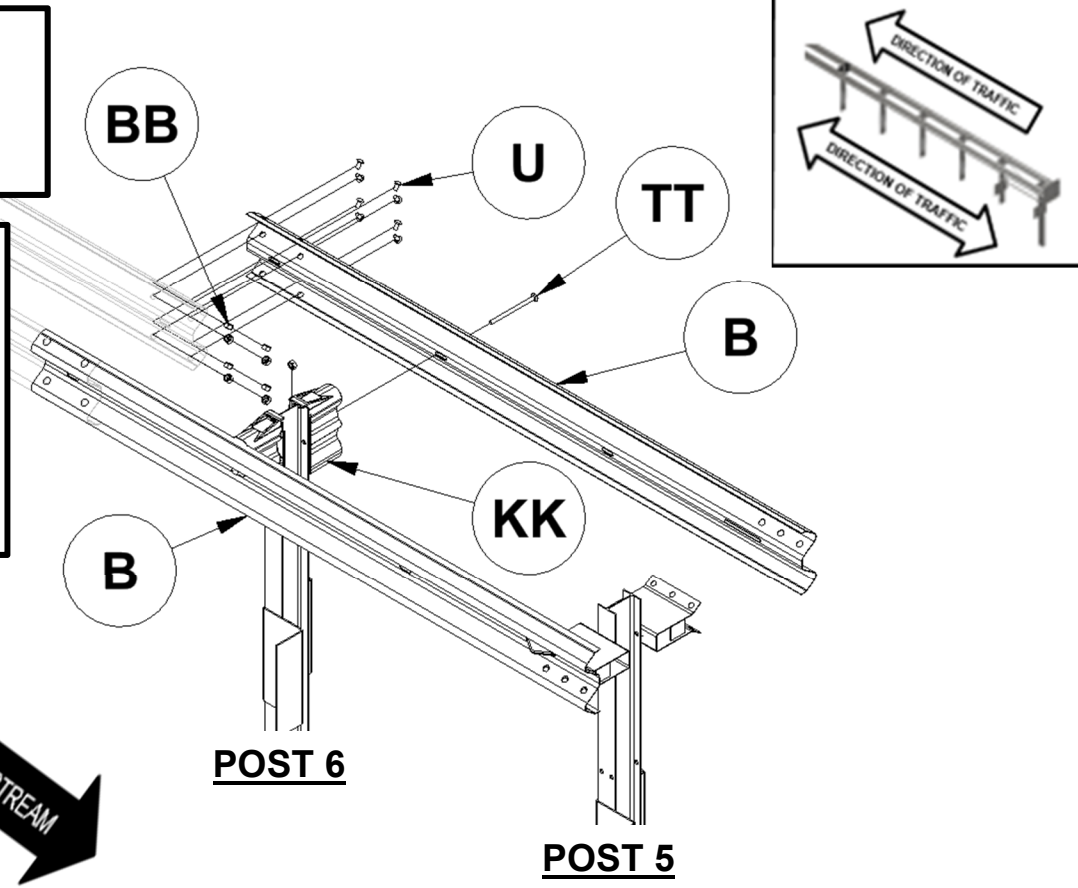

PARTS			INSTRUCTIONS
B	628289A	2 EA	<b>Reference: SS-6288</b> 1. Attach 8" [200 mm] Composite Offset Block (Various) on both sides of Post 6 2. Assemble the MATT™ 12 Gauge Transition Guardrail with Fin-4 (Part B), 9'-4 1/2" [2.858 m] as shown above for both sides using specified hardware (Parts U, BB, TT). 3. At this location <b>ONLY</b> , lap the MATT™ 12 Gauge Transition Guardrail with Fin-4 with the line guardrail system in the <b>direction of the adjacent traffic</b> . <b>Position the fins upstream</b> . 4. Tighten all threaded hardware to a snug position with a minimum of two (2) bolt threads protruding beyond the nut. 5. Guardrail height to be approximately 31" [787 mm], (+1", -0") [+25 mm, -0 mm] above finished grade.
U	3360G	16 EA	
BB	3340G	18 EA	
KK	Various	2 EA	
TT	3500G	2 EA	
Use only Valtir parts that are specified herein for the MATT™ for assembling, maintaining, or repairing the MATT™. Do not utilize or otherwise commingle parts from other systems even if those systems are Valtir systems.			<h3>WARNINGS</h3>  Ensure the MATT™ 12 Gauge Transition Guardrail with Fin-4 at this location <b>ONLY</b> is lapped with the line guardrail in the <b>direction of adjacent traffic</b> . <b>Ensure the fins are positioned upstream.</b> Ensure only 8" [200 mm] Composite Offset Blocks are used. Failure to follow these warnings could result in serious injury or death in the event of a vehicle impact with the system.

# STEP 7

## MATT™ 12 Gauge Slotted Intermediate Guardrail with Fin-3, 6'-3" [1.905 m], Post 4-5

**Note:** The assembly shown for one side of the post is required for both sides of the post.

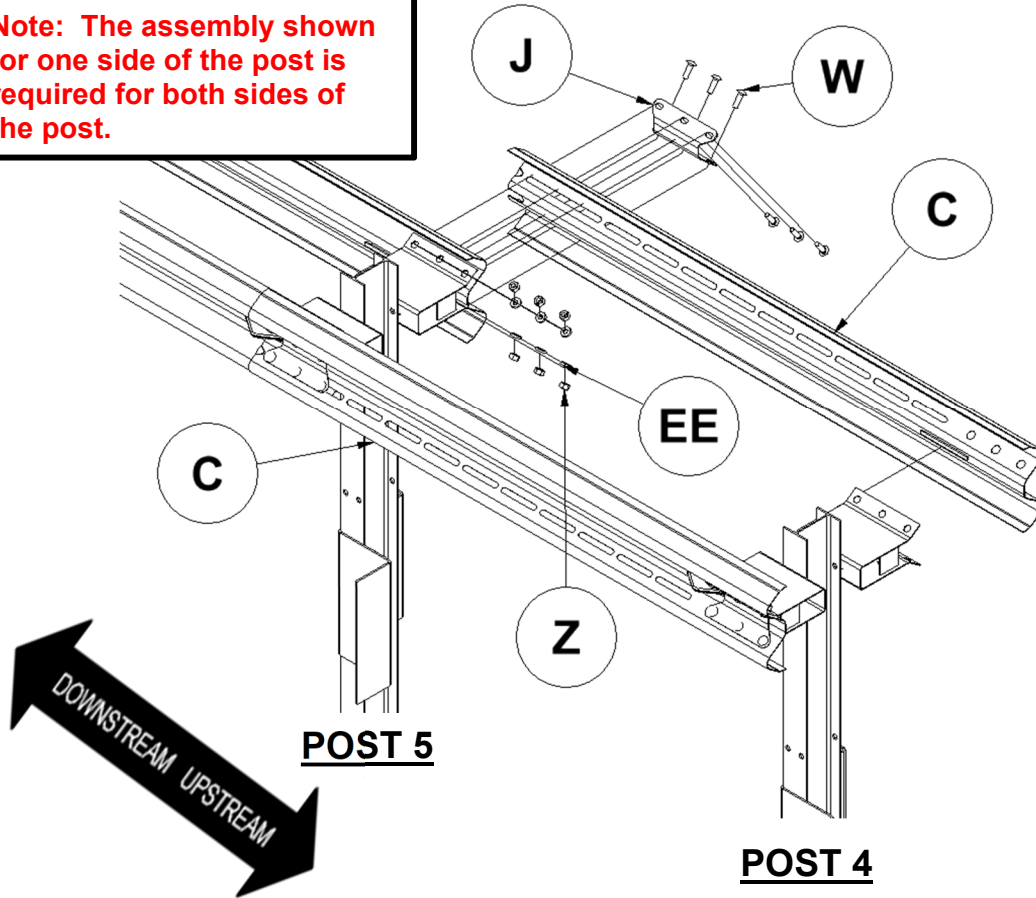

**NOTE:** Part EE is a 5/8" diameter, 1/4" thick flat washer.

Assemble all hardware loosely ensuring bolt is seated for this step.

PARTS			INSTRUCTIONS
C	628337A	2 EA	<b>Reference: SS-6288</b> 1. Assemble the MATT™ 12 Gauge Slotted Intermediate Guardrail with Fin-3 (Part C), 6'-3" [1.905 m] as shown above for both sides using specified hardware (Parts J, W, Z, EE). 2. Ensure the MATT™ 12 Gauge Slotted Intermediate Guardrail with Fin-3 installed between Posts 4 and 5 <b>is lapped to the outside</b> of the MATT™ 12 Gauge Transition Guardrail with Fin-4 and fins are positioned upstream. 3. Ensure the MATT™ Backing Plate (Part J) <b>is on the outside</b> of the MATT™ 12 Gauge Slotted Intermediate Guardrail with Fin-3. 4. Assemble all hardware loosely ensuring bolt is seated for this step. 5. Guardrail height to be approximately 31" [787 mm], (+1", -0") [+25 mm, -0 mm] above finished grade.
J	628338G	2 EA	
W	118614G	12 EA	
Z	3361G	12 EA	
EE	118615G	12 EA	
Use only Valtir parts that are specified herein for the MATT™ for assembling, maintaining, or repairing the MATT™. Do not utilize or otherwise commingle parts from other systems even if those systems are Valtir systems.			<h3>WARNINGS</h3>  Ensure the MATT™ 12 Gauge Slotted Intermediate Guardrail with Fin-3 installed between Posts 4 and 5 <b>is lapped to the outside</b> of the MATT™ 12 Gauge Transition Guardrail with Fin-4. Ensure the MATT™ Backing Plate <b>is on the outside</b> of the MATT™ 12 Gauge Slotted Intermediate Guardrail with Fin-3. Ensure the fins are positioned upstream as shown. Failure to follow these warnings could result in serious injury or death in the event of a vehicle impact with the system.

# STEP 8

## MATT™ 12 Gauge Slotted Intermediate Guardrail with Fin-3, 6'-3" [1.905 m] Post 3-4

**Note: The assembly shown for one side of the post is required for both sides of the post.**

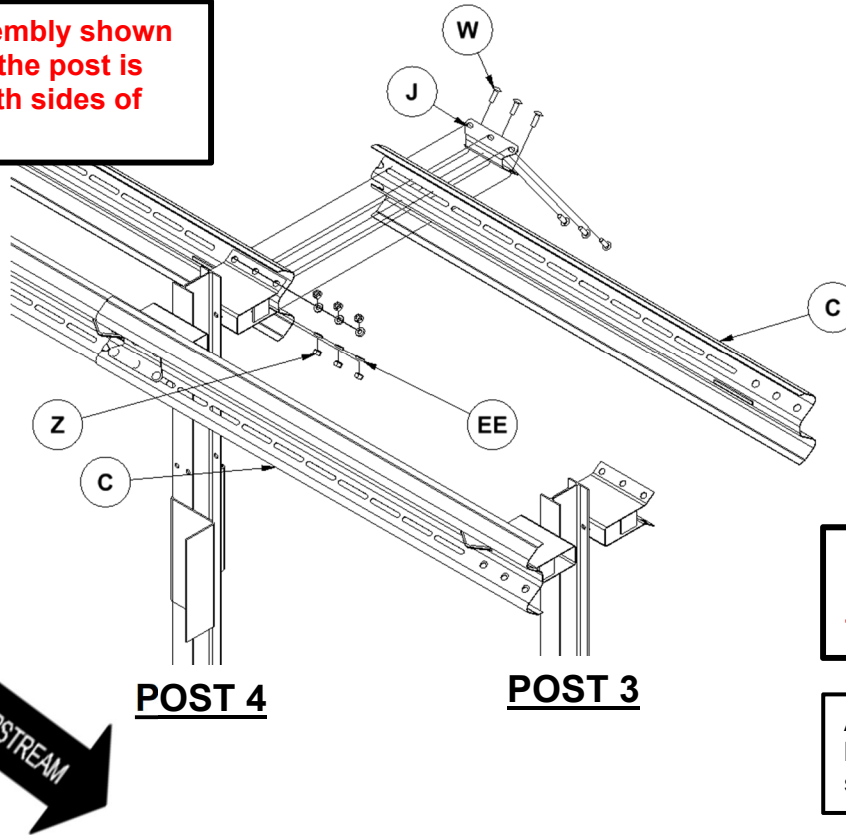

**NOTE: Part EE is a 5/8" diameter, 1/4" thick flat washer.**

Assemble all hardware loosely ensuring bolt is seated for this step.

PARTS			INSTRUCTIONS
C	628337A	2 EA	<b>Reference: SS-6288</b> 1. Assemble the MATT™ 12 Gauge Slotted Intermediate Guardrail with Fin-3 (Part C), 6'-3" [1.905 m] as shown above for both sides using specified hardware (Parts J, W, Z, EE). 2. Ensure the MATT™ 12 Gauge Slotted Intermediate with Fin-3 installed between Posts 3 and 4 <b>is lapped to the outside</b> of the MATT™ 12 Gauge Slotted Intermediate Guardrail with Fin-3 installed between posts 4 and 5 3. Ensure the MATT™ Backing Plate (Part J) <b>is on the outside</b> of the MATT™ 12 Gauge Slotted Intermediate with Fin-3. 4. Assemble all hardware loosely ensuring bolt is seated for this step. 5. Guardrail height to be approximately 31" [787 mm], (+1", -0") [+25 mm, -0 mm] above finished grade.
J	628338G	2 EA	
W	118614G	12 EA	
Z	3361G	12 EA	
EE	118615G	12 EA	
Use only Valtir parts that are specified herein for the MATT™ for assembling, maintaining, or repairing the MATT™. <u>Do not utilize or otherwise commingle parts from other systems even if those systems are Valtir systems.</u>			<b>WARNINGS</b>  Ensure the MATT™ 12 Gauge Slotted Intermediate with Fin-3 installed between Posts 3 and 4 is <b>lapped to the outside</b> of the MATT™ 12 Gauge Slotted Intermediate Guardrail with Fin-3 installed between posts 3 and 4. Ensure the MATT™ Backing Plate <b>is on the outside</b> of the MATT™ 12 Gauge Slotted Intermediate Guardrail with Fin-3. Ensure fins are positioned upstream as shown. Failure to follow these warnings could result in serious injury or death in the event of a vehicle impact with the system.

# STEP 9

## MATT™ 12 Gauge Slotted Intermediate Guardrail-2, 6'-3" [1.905 m]

Note: The assembly shown for one side of the post is required for both sides of the post.

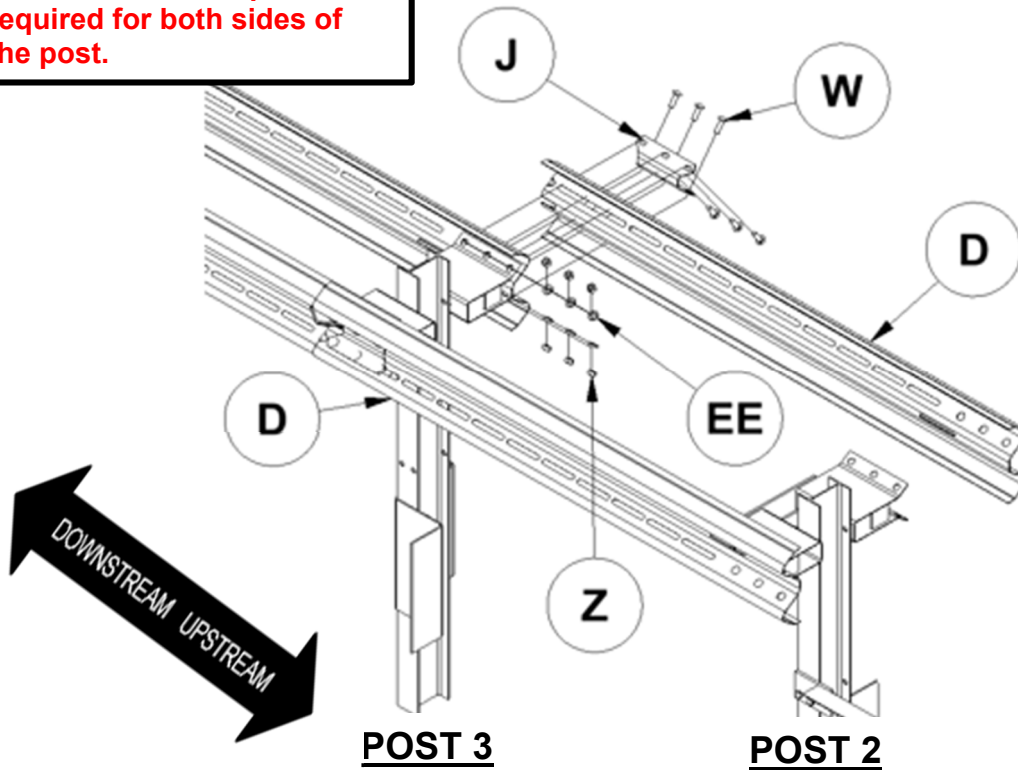
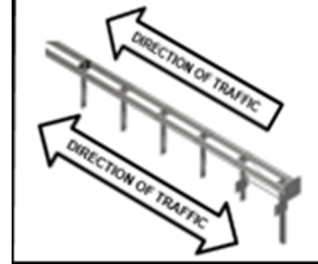

NOTE: Part EE is a 5/8" diameter, 1/4" thick flat washer.

Assemble all hardware loosely ensuring bolt is seated for this step.

PARTS			INSTRUCTIONS
D	628274G	2 EA	<b>Reference: SS-6288</b> 1. Assemble the MATT™ 12 Gauge Slotted Intermediate Guardrail-2 (Part D), 6'-3" [1.905 m] as shown above for both sides using specified hardware (Parts J, W, Z, EE). 2. Ensure the MATT™ 12 Gauge Slotted Intermediate Guardrail-2 installed between Posts 2 and 3 <b>is lapped to the outside</b> of the MATT™ 12 Gauge Slotted Intermediate Guardrail with Fin-3 installed between posts 3 and 4. 3. Ensure the MATT™ Backing Plate (Part J) <b>is on the outside</b> of the MATT™ 12 Gauge Slotted Intermediate Guardrail-2. 4. Assemble all hardware loosely ensuring bolt is seated for this step. 5. Guardrail height to be approximately 31" [787 mm], (+1", -0") [+25 mm, -0 mm] above finished grade.
J	628338G	2 EA	
W	118614G	12 EA	
Z	3361G	12 EA	
EE	118615G	12 EA	
			WARNINGS
Use only Valtir parts that are specified herein for the MATT™ for assembling, maintaining, or repairing the MATT™. <u>Do not utilize or otherwise commingle parts from other systems even if those systems are Valtir systems.</u>			 Ensure the MATT™ 12 Gauge Slotted Intermediate Guardrail-2 installed between Posts 2 and 3 <b>is lapped to the outside</b> of the MATT™ 12 Gauge Slotted Intermediate Guardrail with Fin-3 installed between posts 3 and 4. Ensure the MATT™ Backing Plate (Part J) <b>is on the outside</b> of the MATT™ 12 Gauge Slotted Intermediate Guardrail-2. Ensure fins are positioned upstream as shown. Failure to follow these warnings could result in serious injury or death in the event of a vehicle impact with the system.

# STEP 10

## MATT™ 10 Gauge Slotted Front Guardrail-1 6'-3" [1.905 m]

**Note:** The assembly shown for one side of the post is required for both sides of the post.

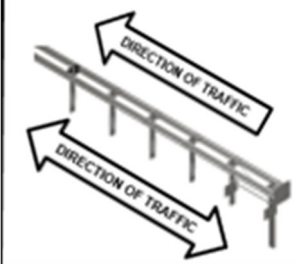
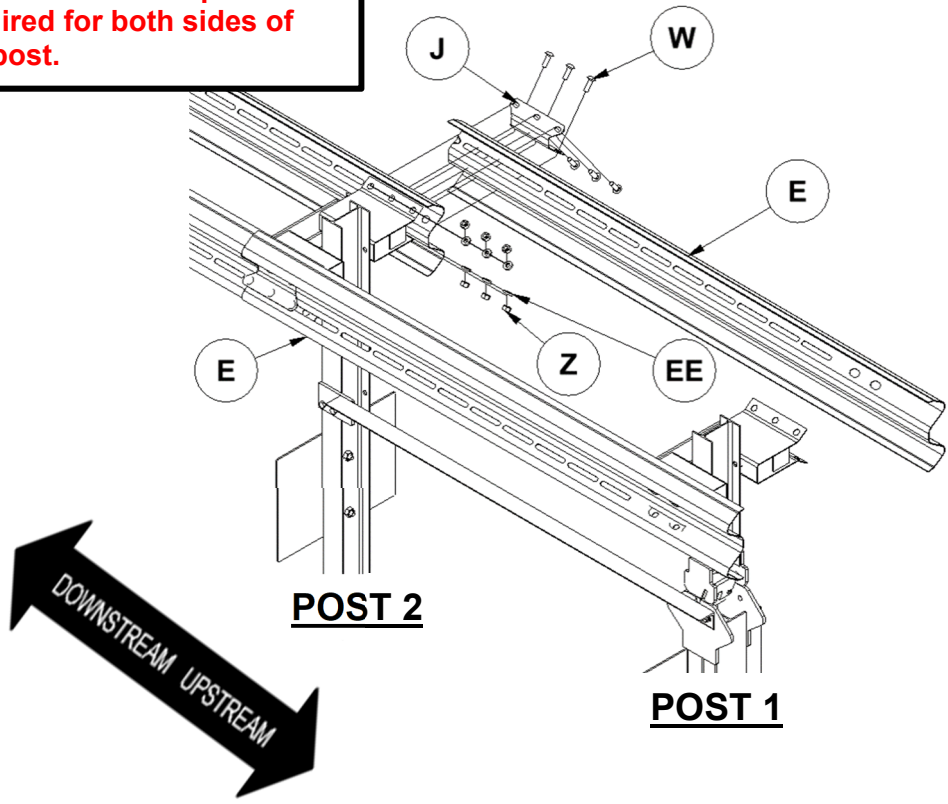

**NOTE:** Part EE is a 5/8" diameter, 1/4" thick flat washer.

Assemble all hardware loosely ensuring bolt is seated for this step.

PARTS			INSTRUCTIONS
E	628347G	5 EA	<b>Reference: SS-6288</b> 1. Assemble the MATT™ Backing Plate (Part J) and MATT™ 10 Gauge Slotted Front Guardrail-1 (Part E), 6'-3" [1.905 m] to the MATT™ 12 Gauge Slotted Intermediate Guardrail-2 as shown above for both sides using specified hardware (Parts W, Z, EE). 2. Ensure the MATT™ 10 Gauge Slotted Front Guardrail-1 <b>is lapped to the outside</b> of the MATT™ 12 Gauge Slotted Intermediate Guardrail-2 3. Ensure the MATT™ Backing Plate <b>is on the outside</b> of the MATT™ 10 Gauge Slotted Front Guardrail-1. 4. Assemble all hardware loosely ensuring bolt is seated for this step. 5. Guardrail height to be approximately 31" [787 mm], (+1", -0") [+25 mm, -0 mm] above finished grade.
J	628338G	2 EA	
W	118614G	12 EA	
Z	3361G	12 EA	
EE	118615G	12 EA	
Use only Valtir parts that are specified herein for the MATT™ for assembling, maintaining, or repairing the MATT™. <u>Do not utilize or otherwise commingle parts from other systems even if those systems are Valtir systems.</u>			<b>WARNINGS</b>  Ensure the MATT™ 10 Gauge Slotted Front Guardrail-1 <b>is lapped to the outside</b> of the MATT™ 12 Gauge Slotted Intermediate Guardrail-2. Ensure the MATT™ Backing Plate <b>is on the outside</b> of the MATT™ 10 Gauge Slotted Front Guardrail-1. Failure to follow these warnings could result in serious injury or death in the event of a vehicle impact with the system.

# STEP 11

## MATT™ Cable Assembly

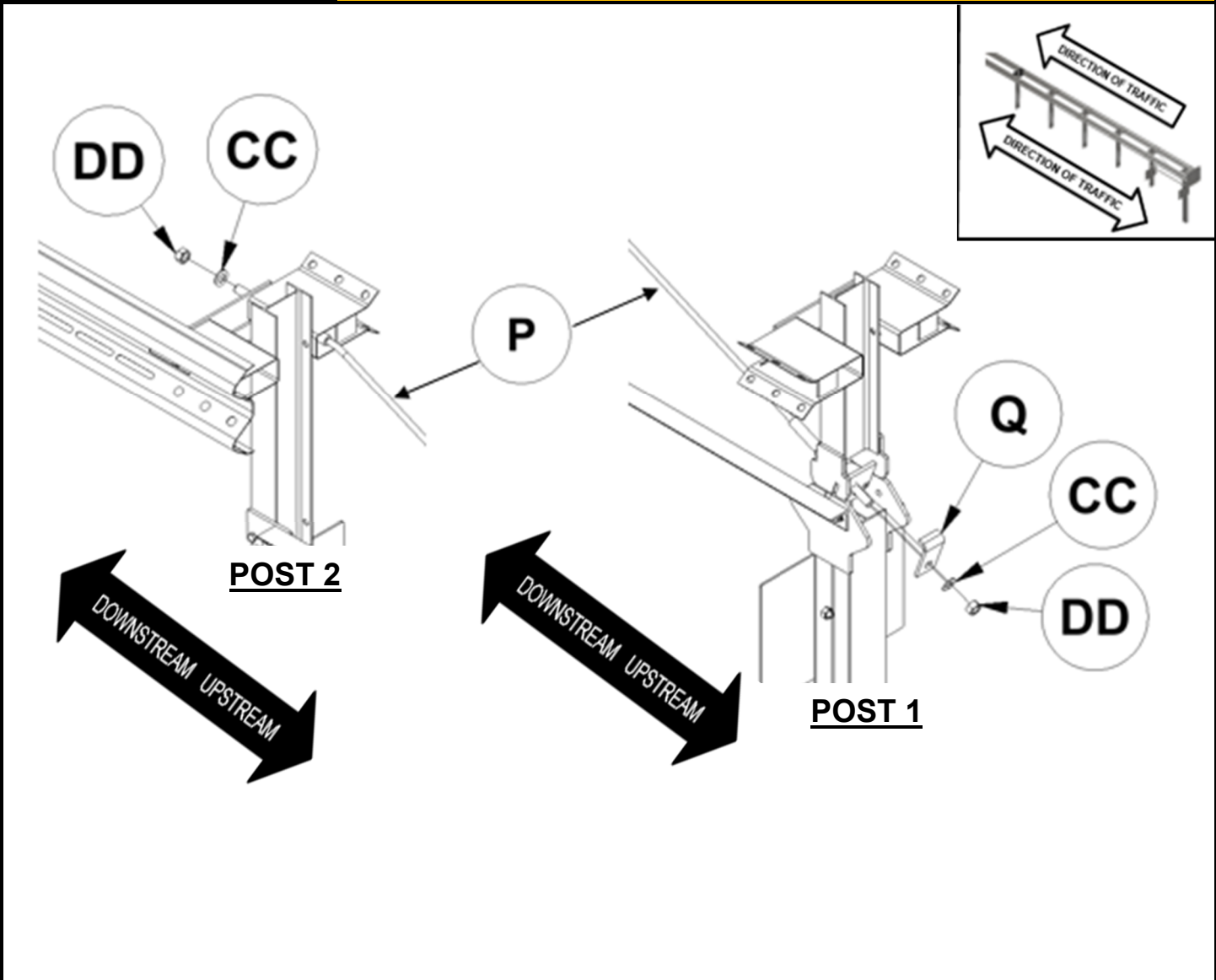

PARTS			INSTRUCTIONS
P	119506G	1 EA	<b>Reference: SS-6288</b>  1. Install the MATT™ Cable Assembly on the side of the Post 2 Double Spacer which is the OPPOSITE of the previously installed MATT™ Angle Strut. 2. Assemble the MATT™ Cable Assembly [Part P] as shown above using specified hardware (Parts Q, CC, DD), remove excess slack from the cable. 3. Ensure that the bent portion of the Cable Anchor Bracket Angle [Part Q] at CR Post 1 is up and hooked over the MATT™ CR Post 1 Top.
Q	33909G	1 EA	
CC	4902G	2 EA	
DD	3910G	2 EA	
<b>WARNINGS</b>			<div style="display: flex; align-items: center;"> <div> <p>Ensure the Cable Anchor Bracket Angle is hooked over the MATT™ CR Post 1 Top.</p> <p>Failure to follow these warnings could result in serious injury or death in the event of a vehicle impact with the system.</p> </div> </div>

P	119506G	1 EA
Q	33909G	1 EA
CC	4902G	2 EA
DD	3910G	2 EA

**Reference: SS-6288**

1. Install the MATT™ Cable Assembly on the side of the Post 2 Double Spacer which is the OPPOSITE of the previously installed MATT™ Angle Strut.
2. Assemble the MATT™ Cable Assembly [Part P] as shown above using specified hardware (Parts Q, CC, DD), remove excess slack from the cable.
3. Ensure that the bent portion of the Cable Anchor Bracket Angle [Part Q] at CR Post 1 is up and hooked over the MATT™ CR Post 1 Top.

Use only Valtir parts that are specified herein for the MATT™ for assembling, maintaining, or repairing the MATT™. Do not utilize or otherwise commingle parts from other systems even if those systems are Valtir systems.

**WARNINGS**

Ensure the Cable Anchor Bracket Angle is hooked over the MATT™ CR Post 1 Top.

Failure to follow these warnings could result in serious injury or death in the event of a vehicle impact with the system.

# STEP 12

## MATT™ 10 Gauge Head Rail Assembly 1'-9 3/4" [552 mm]

**Note:** The assembly shown for one side of the post is required for both sides of the post.

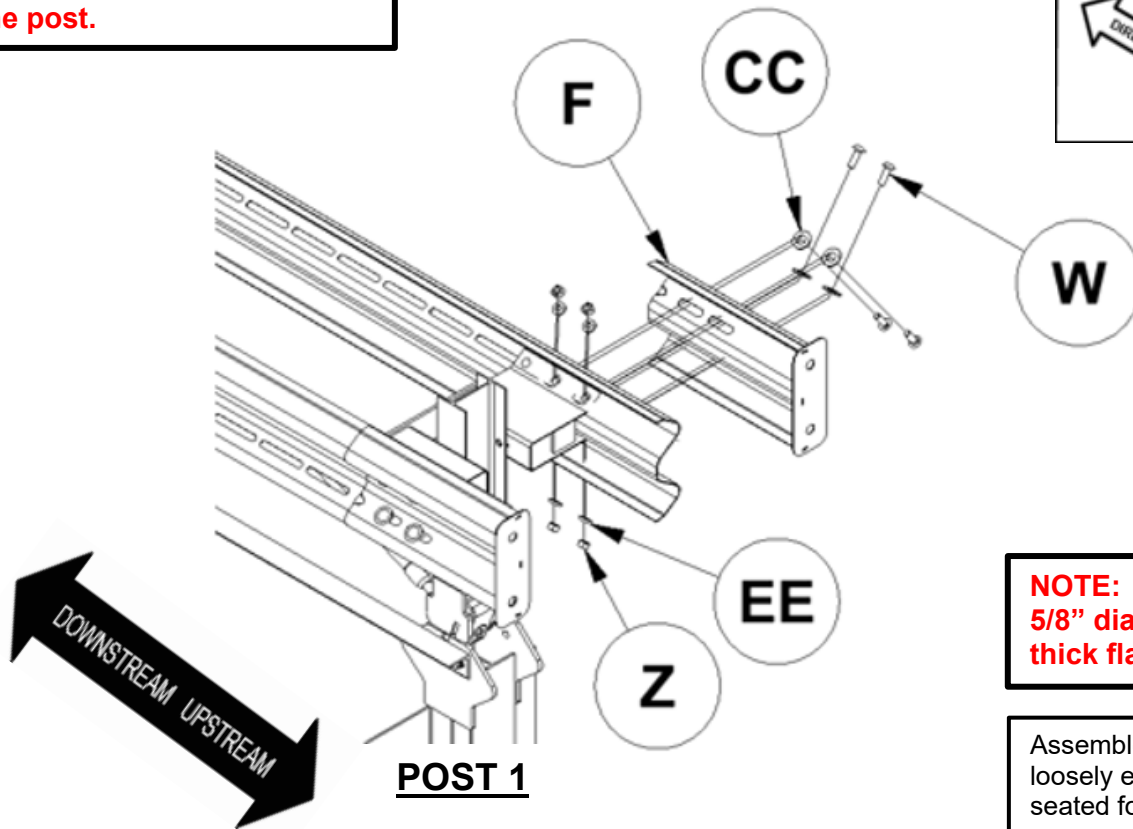
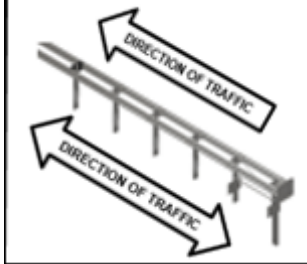

**NOTE:** Part EE is a 5/8" diameter, 1/4" thick flat washer.

Assemble all hardware loosely ensuring bolt is seated for this step.

Installation tip: Some contractors have found it more efficient to preassemble some portions of Steps 12-14

PARTS		
F	628339A	2 EA
W	118614G	8 EA
Z	3361G	8 EA
CC	4902G	8 EA
EE	118615G	8 EA
<b>Reference: SS-6288</b> <ol style="list-style-type: none"> <li>1. Assemble the MATT™ 10 Gauge Head Rail (Part F), 1'-9 3/4" [552 mm] to the MATT™ 10 Gauge Slotted Front Guardrail-1 as shown above for both sides using specified hardware (Parts W, CC, EE), approximately centering CC.</li> <li>2. Ensure the two <b>Upstream</b> holes in the MATT™ Double Spacer are used to assemble the MATT™ 10 Gauge Head Rail and MATT™ 10 Gauge Slotted Front Guardrail-1.</li> <li>3. Ensure the MATT™ 10 Gauge Head Rail is lapped to the outside of the MATT™ 10 Gauge Slotted Front Guardrail-1.</li> <li>4. Assemble all hardware loosely ensuring bolt for this step.</li> </ol>		
WARNINGS		
<p>Use only Valtir parts that are specified herein for the MATT™ for assembling, maintaining, or repairing the MATT™. <u>Do not utilize or otherwise commingle parts from other systems even if those systems are Valtir systems.</u></p>		<p>Ensure the MATT™ 10 Gauge Head Rail <b>is lapped to the outside</b> of the MATT™ 10 Gauge Slotted Front Guardrail-1.</p>
		<p>Ensure the two <b>Upstream</b> holes in the MATT™ Double Spacer are used to assemble the MATT™ 10 Gauge Head Rail. Failure to follow this warning could result in serious injury or death in the event of a vehicle impact with the system.</p>



# STEP 13

## MATT™ Delineation Assembly

**Note: The Delineation Sheeting must be notched in four (4) places for the gusset plates.**

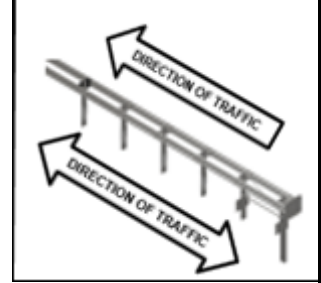
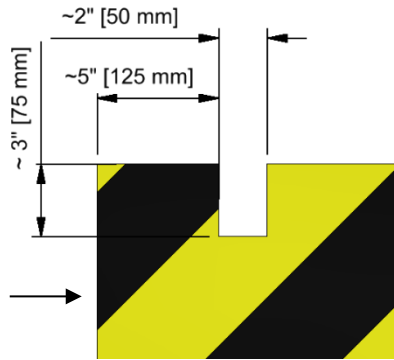

NOTCH DETAIL TYPICAL AT ALL 4 CORNERS

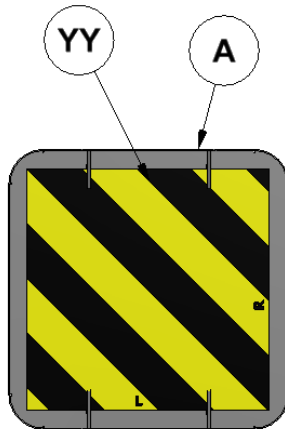

Median

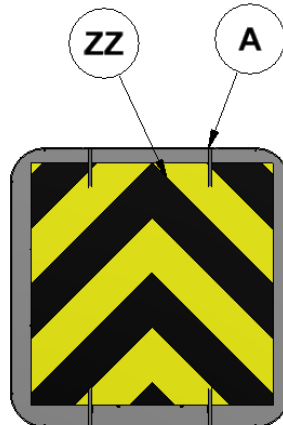

Gore

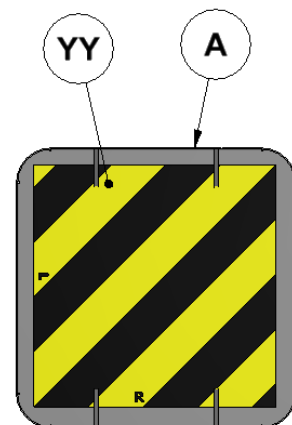

Roadside

PARTS			INSTRUCTIONS
A	628342B	1 EA	<b>Reference: SS-6288</b> 1. For median/roadside application, attach the Delineation Sheeting (Part YY) to the MATT™ Impact Head (Part A) as shown above. Rotate as appropriate. 2. For gore application, attach the Delineation Sheeting (Part ZZ) to the MATT™ Impact Head (Part A).  <b>Note:</b> Manufacturer suggests that user provide delineation (reflective sheeting) as required by the state/specifying agency for terminals.  <b>Note:</b> Valtir offers two (2) specific reflective sheeting options for an additional charge. Valtir makes no guarantees they meet the minimum specifications, comply with MUTCD requirements or comply with state/specifying agency requirements.
YY	105379B	1 EA	
<b>OR</b>			
ZZ	105380B	1 EA	
Use only Valtir parts that are specified herein for the MATT™ for assembling, maintaining, or repairing the MATT™. <u>Do not utilize or otherwise commingle parts from other systems even if those systems are Valtir systems.</u>			<b>WARNINGS</b>  Ensure delineation (reflective sheeting) used on the MATT™ Impact Head meets state/specifying agency's MUTCD for proper delineation. Ensure steel delineator posts are a minimum of 3'-0" [1 m] in front (upstream) of the MATT™. Failure to follow these warnings could result in serious injury or death in the event of a vehicle impact with the system

# STEP 14

## MATT™ Head Tube Assembly

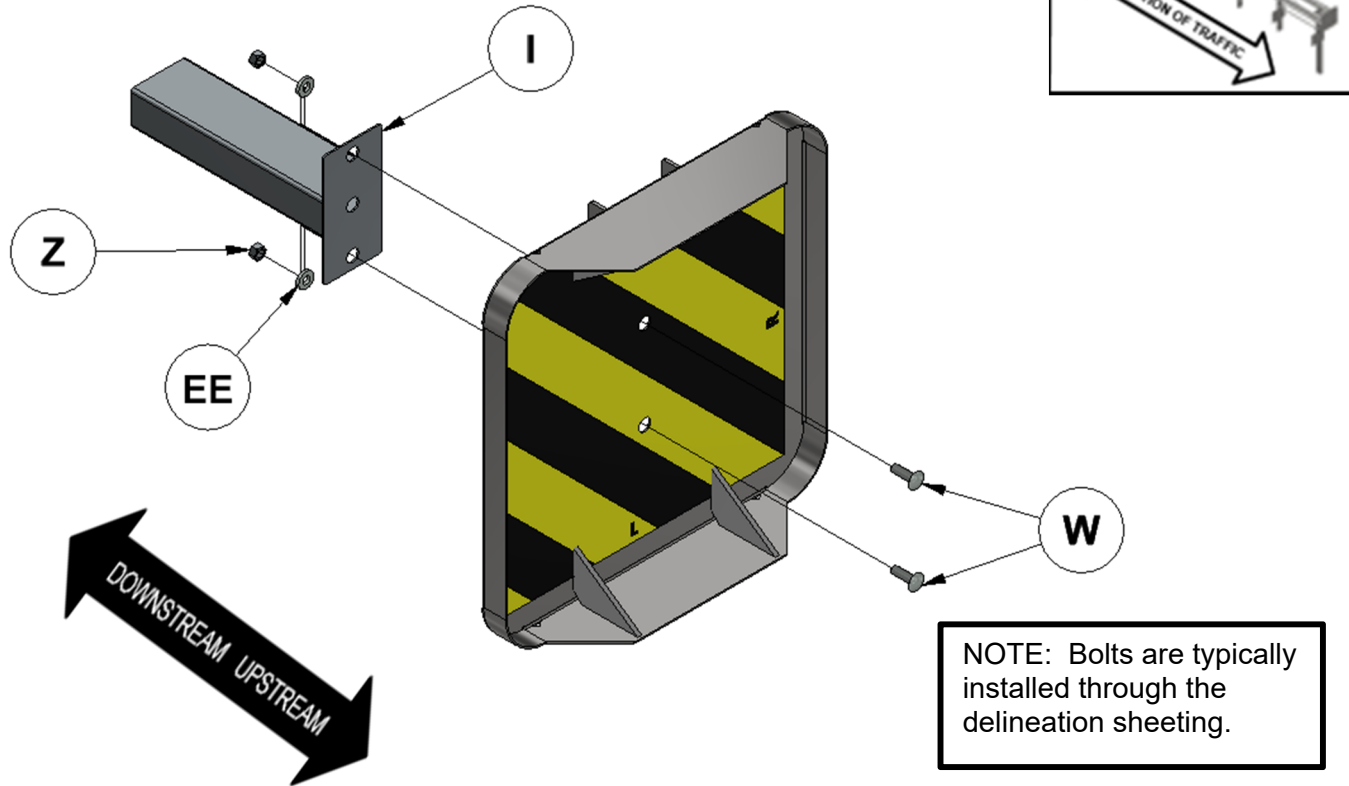

NOTE: Bolts are typically installed through the delineation sheeting.

PARTS			INSTRUCTIONS
-------	--	--	--------------

I	628275A	1 EA	<b>Reference: SS-6288</b>  1. Assemble the MATT™ Head Tube (Part I) to the MATT™ Impact Head as shown above using specified hardware (Parts W, Z, EE). 2. Insert 5/8" x 2" GR Bolt through the delineation sheeting and tighten the 5/8" Heavy Hex Nut used to assemble the MATT™ Head Tube to the MATT™ Impact Head to <b><u>65 ft-lb [88 Nm] (+/- 3 ft-lb) [+/- 4 Nm]</u></b> using a calibrated torque wrench.
W	118614G	2 EA	
Z	3361G	2 EA	
EE	118615G	2 EA	
628342B, from Step 13			

	WARNINGS
--	----------

Use only Valtir parts that are specified herein for the MATT™ for assembling, maintaining, or repairing the MATT™. Do not utilize or otherwise commingle parts from other systems even if those systems are Valtir systems.	Ensure the 5/8" Heavy Hex Nut used to assemble the MATT™ Head Tube to the MATT™ Impact Head is tightened to a <b><u>torque of 65 ft-lb [88 Nm] (+/- 3 ft-lb) [+/- 4 Nm]</u></b> using a calibrated torque wrench. Failure to follow this warning could result in serious injury or death in the event of a vehicle impact with the system.
---	--

# STEP 15

## MATT™ Impact Head Assembly

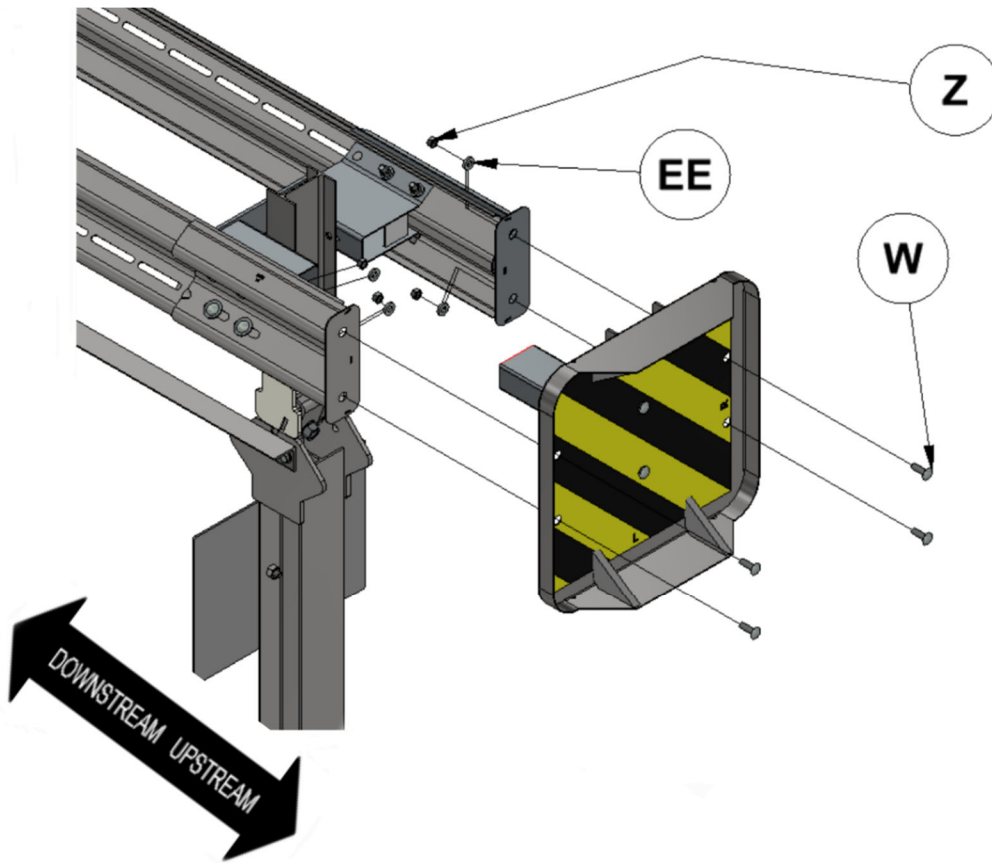

NOTE: Bolts are typically installed through the delineation sheeting.

PARTS			INSTRUCTIONS
W	118614G	4 EA	<b>Reference: SS-6288</b> 1. Assemble the MATT™ Impact Head to the MATT™ 10 Gauge Head Rail as shown above using specified hardware (Parts W, Z, EE). 2. Insert 5/8" x 2" GR Bolt through the delineation sheeting and tighten the 5/8" Heavy Hex Nut used to Assemble the MATT™ Impact Head to the MATT™ 10 Gauge Head Rail, to <b>65 ft-lb [88 Nm] (+/- 3 ft-lb) [+/- 4 Nm]</b> using a calibrated torque wrench. 3. Ensure the MATT™ Head Tube is within 1/4" [6mm] of touching the MATT™ CR Post 1 Top by pushing the MATT™ Impact Head and the MATT™ 10 Gauge Head Rails back evenly.
Z	3361G	4 EA	
EE	118615G	4 EA	
628342B, from Step 13			<b>WARNINGS</b>  Ensure 5/8" Heavy Hex Nuts attaching the MATT™ Impact Head to the MATT™ 10 Gauge Head Rail are <b>torqued to 65 ft-lb [88 Nm] (+/- 3 ft-lb) [+/- 4 Nm]</b> using a calibrated torque wrench. Ensure the MATT™ Head Tube is within 1/4" [6 mm] of touching the MATT™ CR Post 1 Top. Failure to follow these warnings could result in serious injury or death in the event of a vehicle impact with the system.
Use only Valtir parts that are specified herein for the MATT™ for assembling, maintaining, or repairing the MATT™. <u>Do not utilize or otherwise commingle parts from other systems even if those systems are Valtir systems.</u>			

# STEP 16

## MATT™ Nuts To Be Torqued And Cable Tensioning

Number in balloon represents the number of “W”, 5/8” x 2” GR Bolts, Grade 5 (A325), and “Z”, 5/8” Heavy Hex Nuts, A563 DH that are torqued to 65 ft-lb [88 Nm], (+/- 3 ft-lb) [+/- 4 Nm], at each location.

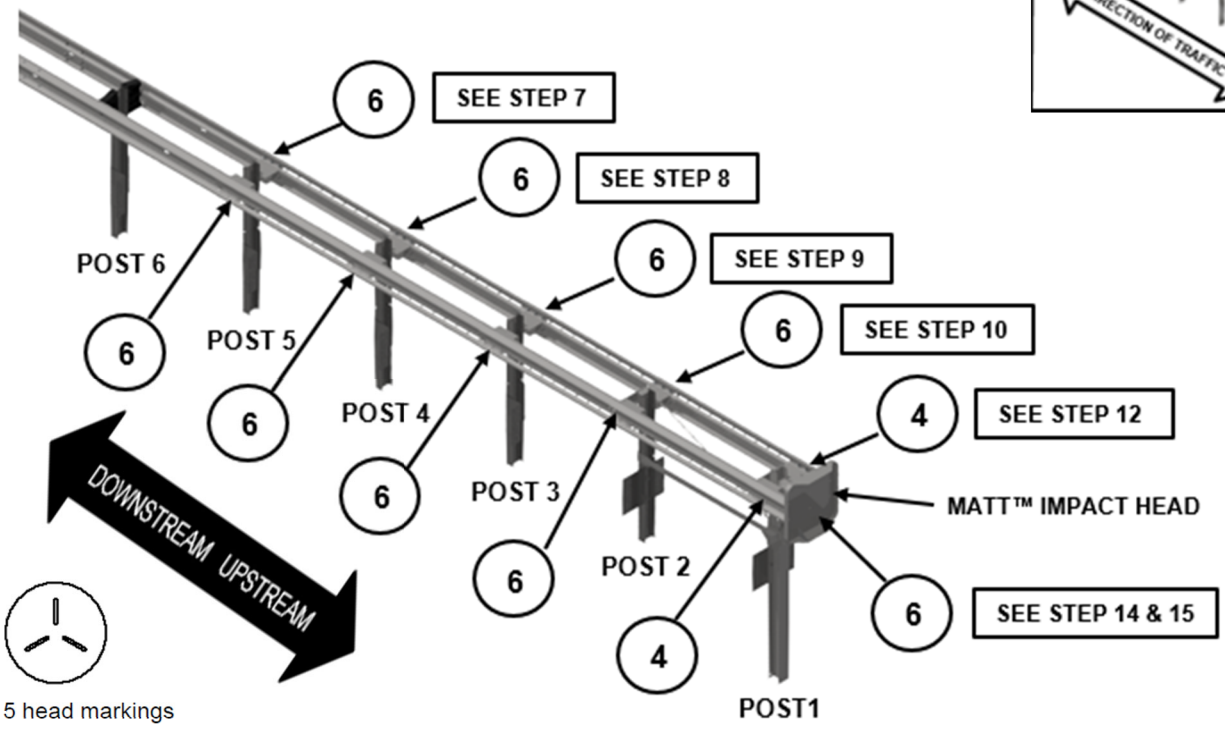
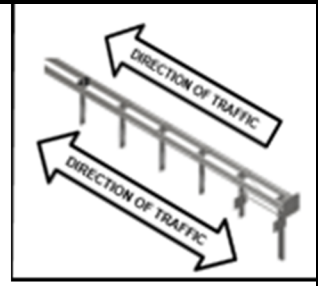

\*Grade 5 head markings

PARTS	INSTRUCTIONS
-------	--------------

	<p><b>Reference: SS-6288</b></p> <ol style="list-style-type: none"> <li>1. Ensure all bolts identified above and installed loosely ensuring bolt is seated for this step in earlier Steps are torqued to 65 ft-lb [88 Nm] (+/-3 ft-lb) [+/-4 Nm] using a calibrated torque wrench.</li> <li>2. Ensure the 1” flat washers installed in Step 12 under the bolt head attaching the MATT™ 10 Gauge Head Rail are approximately centered on the bolt head before tightening.</li> <li>3. Ensure that the bent portion of the Cable Anchor Bracket Angle (See Step 11) at CR Post 1 is up and hooked over the MATT™ CR Post 1 Top.</li> <li>4. Restrain the cable with locking pliers and/or a pipe wrench while tightening nut with a wrench, at the end being tightened to avoid twisting the cable.</li> <li>5. Tighten the cable until it is taut. The cable is considered taut when it does not deflect more than 1” [25 mm] when pressure is applied by hand in an up or down direction.</li> </ol>
--	--

	WARNINGS
--	----------

<p>Use only Valtir parts that are specified herein for the MATT™ for assembling, maintaining, or repairing the MATT™. <u>Do not utilize or otherwise commingle parts from other systems even if those systems are Valtir systems.</u></p>	<div style="display: flex; align-items: center;"> <div> <p>Ensure all bolts identified above and installed loosely ensuring bolt is seated for this step in earlier Steps are <b><u>torqued to 65 ft-lb [88 Nm] (+/- 3 ft-lb) [+/- 4 Nm]</u></b> using a calibrated torque wrench. Ensure the 1” flat washers installed in Step 14 under the bolt head attaching the MATT™ 10 Gauge Head Rail are approximately centered on the bolt head before tightening. Ensure cable is taut. Failure to follow these warnings could result in serious injury or death in the event of a vehicle impact with the system.</p> </div> </div>
---	---

# **MATT™ Assembly/Repair Checklist**

## **(File with Project/Maintenance Records)**

Performed by: \_\_\_\_\_

Date: \_\_\_\_\_

Location: \_\_\_\_\_

- 1. Ensure proper site grading complies with state/specifying agency guidelines and/or AASHTO Roadside Design Guide, whichever is more stringent. (p 8)
- 2. Ensure required traffic control is in place to conduct MATT™ assembly. (p 5)
- 3. Ensure only Valtir provided MATT™ parts are used for the assembly of the MATT™ and that all parts are free of damage. (p 5)
- 4. Under NO circumstances shall the rail within the MATT™ be curved, between Post 1 and Post 6. Ensure all MATT™ post spacings are 6'-3" [1.905 m] on center. (p 8)
- 5. Ensure the Strut Hole of the MATT™ CR Post 1 Bottom with Soil Plate is **upstream** and the Post is 4" [100 mm] (+1", -0") [+25 mm, -0 mm] above the finished grade. (pp 17, 21-22).
- 6. Ensure Soil Plates are installed on the downstream side of Posts 1-6 (pp 17-20)
- 7. Ensure the center of the SYTP® yielding holes at Posts 2-5 are approximately centered at finished grade. (pp 18-20)
- 8. Ensure the MATT™ Strut Adapter Plate (at Post 2) and Strut are installed between Post 1 and 2 on the post side **OPPOSITE** the closest traffic, when assembled in a Median or Roadside application. When assembled in a Gore application, it is acceptable to place them on either side of the post(s). Ensure the toe of the Strut's vertical leg is pointed down. (p 21)
- 9. Ensure the **downstream** slotted holes in the MATT™ Double Spacer is bolted to the **downstream** hole of the MATT™ CR Post 1 Top and the MATT™ SYTP® (Post 2). (p 23)
- 10. Ensure the **upstream** slotted hole in the MATT™ Spacer (Posts 3-5) is bolted to the MATT™ SYTP® with Soil Plate using the **upstream** hole in the post. (p 24)
- 11. Ensure all MATT™ Guardrails are installed 31" [787 mm] (+1", -0") [+/- 25 mm, -0] from finished grade. (pp various)
- 12. Ensure all MATT™ 12 Gauge Transition Guardrails with Fin-4, at post location 6, are **lapped in the direction** of the nearest adjacent traffic and fins are positioned upstream. (p 25)
- 13. Ensure the MATT™ 12 Gauge, Slotted Intermediate Guardrails with Fin-3 are **lapped to the outside** of the MATT™ 12 Gauge Transition Guardrails with Fin-4. (p 26)
- 14. Ensure the MATT™ 12 Gauge, Slotted Intermediate Guardrails with Fin-3 are **lapped to the outside** of the MATT™ 12 Gauge, Slotted Intermediate Guardrails with Fin-3. (p 27)
- 15. Ensure the MATT™ 12 Gauge, Slotted Intermediate Guardrails-2 are **lapped to the outside** of the MATT™ 12 Gauge, Slotted Intermediate Guardrails with Fin-3. (p 28)
- 16. Ensure the MATT™ 10 Gauge, Slotted Front Guardrails-1 are **lapped to the outside** of the MATT™ 12 Gauge, Slotted Intermediate Guardrails-2. (p 29)
- 17. Ensure the MATT™ 10 Gauge Head Rails are **lapped to the outside** of the MATT™ 10 Gauge Slotted Front Guardrails-1. (p 31)
- 18. Ensure the MATT™ Backing Plate is **assembled on the outside** of the MATT™ Guardrail Panels at Posts 2, 3, 4 and 5. (pp 26-29)
- 19. Ensure the 5/8" heavy flat washers (1/4" thick) are placed between the nut and spacers at Posts 1-5. (pp 26-29)
- 20. Ensure the MATT™ Head Tube is attached to the MATT™ Impact Head and it is less than 1/4" [6mm] from the MATT™ CR Post 1 Top. (pp 33-34)
- 21. Ensure all MATT™ fasteners identified in Step 16 are **torqued to 65 ft-lb [88 Nm], (+/- 3 ft-lb) [+/- 4 Nm]**. (p 35)
- 22. Ensure all MATT™ fasteners that are NOT required to be torqued are tightened to a snug position with a minimum of two (2) bolt threads protruding beyond the nut. (Various pp)
- 23. Ensure the Cable Anchor Bracket Angle is hooked over the MATT™ CR Post 1 Top and the cable is taut. (pp 30-35)
- 24. Ensure delineation is placed on the MATT™ Impact Head per MUTCD and/ or state/specifying agency. (p 32)
- 25. Ensure any steel delineator posts are a minimum of 3'-0" [1 m] upstream from the MATT™ Impact Head. (p 32)

# **MATT™ Routine Inspection Checklist**

## **(File with Maintenance Records)**

Performed by: \_\_\_\_\_

Date: \_\_\_\_\_

Location: \_\_\_\_\_

Valtir recommends the state/specifying agency develop and administer their own end terminal inspection program, based on location of unit, volume of traffic and impact history.



**Important: The MATT™ and all of its components shall be inspected for damage after every impact. Repair using only Valtir parts that are specified for use within this MATT™ Product Description Assembly Manual.**

If no end terminal inspection program exists, Valtir recommends visual drive-by inspections at least once every month and walk-up inspections every six (6) months. These inspections shall, at a minimum, consist of:

### **Visual Drive-By Inspections (Recommended Frequency: Monthly)**

- Check for damage caused by vehicle impacts.
- Check for damage caused by impacts from snowplow, mowing or roadway operations.
- Check for misalignment.
- Check for missing system components.
- Check for vandalism.
- Check for damage caused by adverse weather conditions (i.e. erosion, weight of snow, UV).
- Check that the anchor cable appears taut.

### **Walk-Up Inspections (Recommended Frequency: Every Six (6) Months)**

Walk-Up Inspections include ALL Visual Drive-By Inspection items (listed above) as well as the items listed below.

- Ensure required traffic control is in place to conduct walk-up inspection.
- Clear and dispose of any debris or trash found on the MATT™ site, which may interfere with the performance of the MATT™.
- Check that fasteners are fully tightened. See Step 16 for torqued nut locations. All other locations are to be tightened to a snug position with a minimum of two (2) bolt threads protruding beyond the nut.
- Check for erosion to the site grading around the system.
- Ensure that the MATT™ Anchor Cable is taut and the Bearing Plate is properly positioned.
- Ensure the MATT™ Guardrail Panels are lapped correctly allowing each of the upstream guardrail panels to translate over the downstream guardrail panels.

If any of the above items are identified during the inspection process, swift action shall be taken to correct and repair the MATT™ to working condition as outlined in the MATT™ Product Description Assembly Manual, latest edition.

## Appendix A

### AASHTO Roadside Design Guide **Roadside (Shoulder) Grading Detail**

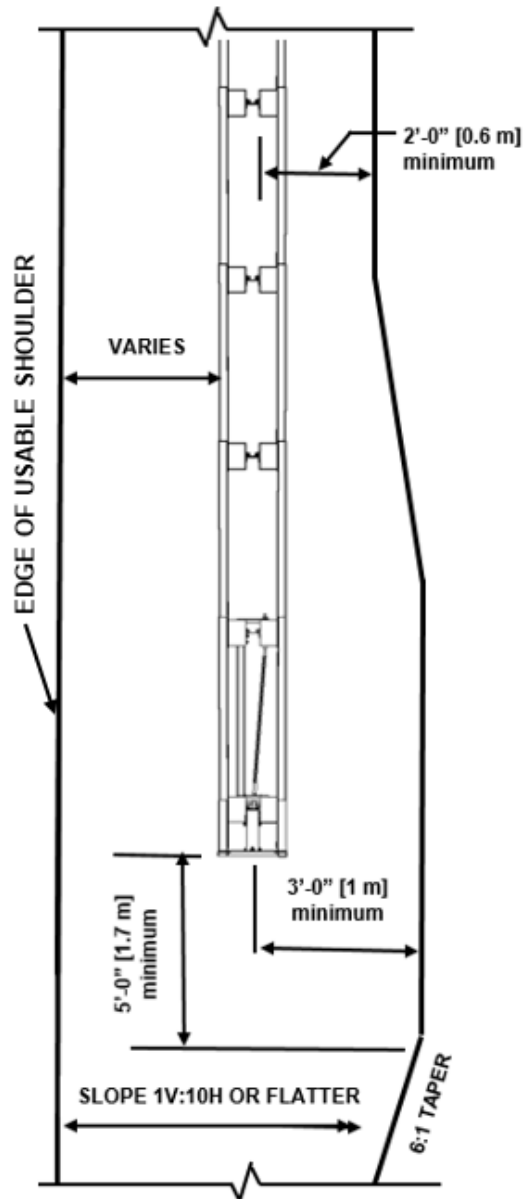

NOTE: Refer to AASHTO Roadside Design Guide, 4<sup>th</sup> Edition 2011, Section 8.3.3 Site Grading Consideration for Terminals, pp 8-4 through 8-6.

### **MATT™ Roadside (Shoulder) Grading Detail**

Detail derived from information contained in the AASHTO Roadside Design Guide, 4<sup>th</sup> Edition 2011



Important: Valtir does not direct grading. Proper site grading must be accomplished before assembly of the MATT™ System in accordance with state/specifying agency guidelines or the AASHTO Roadside Design Guide, whichever is more stringent. Failure to follow this warning could result in serious injury or death in the event of a vehicle impact with the system.

## Appendix B

### AASHTO Roadside Design Guide **Median** Grading Detail

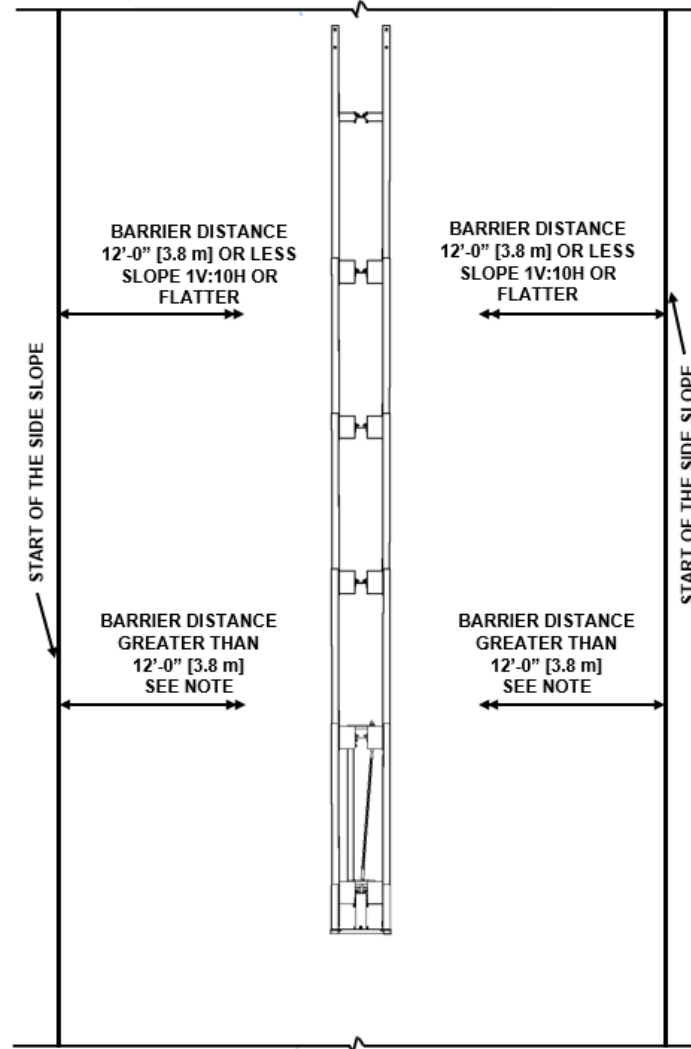

**NOTE:** Refer to AASHTO Roadside Design Guide, 4<sup>th</sup> Edition 2011, Section 5.6.2.2 Slopes, pp 5-46 through 5-48 for slope criteria.

### **MATT™** **Median** Grading Detail

Detail derived from information contained in the AASHTO Roadside Design Guide, 4<sup>th</sup> Edition 2011



**Important:** Valtir does not direct grading. Proper site grading must be accomplished before assembly of the MATT™ System in accordance with state/specifying agency guidelines or the AASHTO Roadside Design Guide, whichever is more stringent. Failure to follow this warning could result in serious injury or death in the event of a vehicle impact with the system.



# Appendix C

## Alternate Foundations for Installations

The MATT™ posts are inserted into the soil using an auger/drill or post pounding equipment for placement. If an auger is used, ensure diameter is large enough to allow for proper compaction of state/specifying agency approved fill material. All MATT™ posts are to be assembled within established standard construction tolerances, including being plumb. Compaction must be accomplished for all posts in accordance with state/specifying agency guidelines.

---

### Alternative installations for MATT™ Post 1-6, when encountering solid rock during assembly:

- **For ALL options/steps indicating a hole is made into soil or rock and the post inserted into the hole, the hole must be filled, to grade, with compactible materials and appropriately tamped/consolidated, after post installation.**
- The standard installation for posts 1-6 may be completed for ANY/ALL posts, even if ~encountering solid rock, if the contractor chooses to install as specified.

#### **Post 1**

- If solid rock is encountered within 0" – 24" [0 mm – 610 mm] below grade make a 9" [229 mm] diameter hole into the rock to allow the full 72" [1829 mm] embedment of the post without soil plate.
- If solid rock is encountered between 24" – 72" [610 mm – 1829 mm] below grade, make a 9" [229 mm] diameter hole into the rock to allow the full 72" [1829 mm] embedment of the post utilizing the soil-plated post 1.

#### **Post 2**

- If solid rock is encountered within 0" – 24" [0 mm – 610 mm] below grade make an 8" – 9" [203 mm – 229 mm] hole to allow the full 40" [1016 mm] embedment of the post without soil plate.
- If solid rock encountered between 24" – 40" [610 mm – 1016 mm] below grade, make an 8" – 9" [203 mm – 229 mm] diameter hole into the rock to allow the full 40" [1016 mm] embedment of the post utilizing the soil-plated post 2.

#### **Post 3-6**

- If solid rock is encountered within 0" – 18" [0 mm – 457 mm] below grade in a **median/gore** application.
  - Make a ~8" x ~21" [~203 mm - ~533 mm] oval or rectangular hole 24" [610 mm] deep from grade. In the center at the bottom of the hole, make an 8" – 9" [203 mm – 229 mm] diameter hole, 16" [406 mm] deep to allow the full 40" [1016 mm] embedment of the post.
- If solid rock is encountered within 0" – 18" [0 mm 457 mm] below grade in a roadside/shoulder application.
  - Make a ~8" x ~21" [~203 mm ~533 mm] oval or rectangular hole 24" [610 mm] deep from grade. At the bottom of the 24" [610 mm] hole, make an 8" – 9" [203 mm – 229 mm] diameter hole, 16" [406 mm] deep to allow the full 40" [1016 mm] embedment of the post.
  - The post shall be installed on the "traffic" side of the hole (see AASHTO RDG for details), without a soil plate – or – as specified by the state/specification agency and/or the AASHTO RDG – latest edition.
- If solid rock is encountered between 18" – 40" [457 mm – 1016 mm] below grade, for any applications (median, gore, roadside, or shoulder), make an 8" – 9" [203 mm – 229 mm] diameter hole to allow the full 40" [1016 mm] length post installation embedment. Install post without a soil plate.

### Alternative installations for MATT™ Post 1, when encountering any below grade obstacle which conflicts with the full depth installation of Post 1, such as utilities, solid rock, or an underground structure:

- **WARNING:** All three (3) alternative Post 1 foundation options shown below REQUIRE the concrete to cure to a minimum of 2,800 psi [19.3 MPa] PRIOR to attaching the MATT™ CR Post 1 Top (ID: K) or in any way moving or loading the MATT™ CR Post 1 Bottom (ID:L).

# Appendix C

## Alternate Foundations for Installations

Case 1: Below grade obstacles between 36" [914 mm] and 48" [1219 mm].

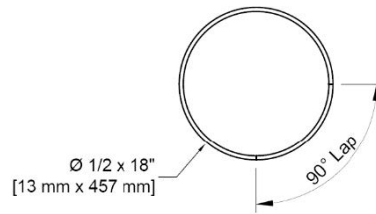
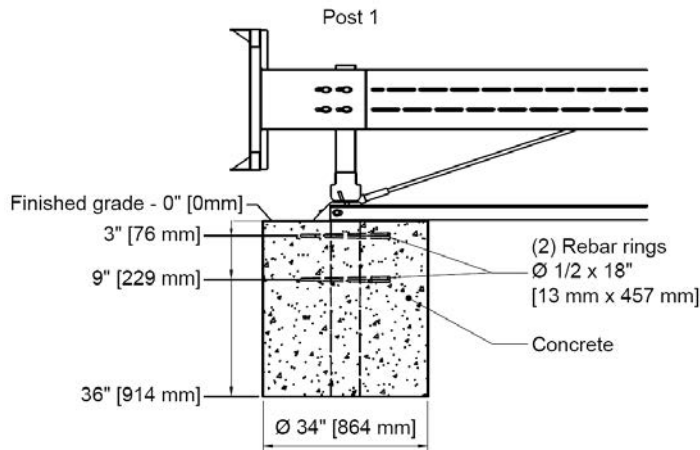

Grade 60 Ø 1/2 x 18" [13 mm x 457 mm] Rebar ring

Case 2: Below grade obstacles between 48" [1219 mm] and 60" [1524 mm].

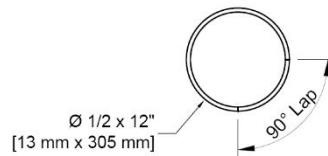
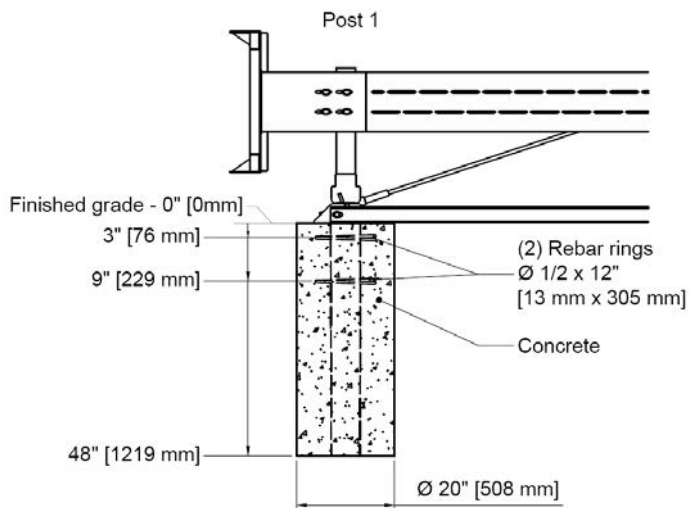

Grade 60 Ø 1/2 x 12" [13 mm x 305 mm] Rebar ring

# Appendix C

## Alternate Foundations for Installations

Case 3: Below grade obstacles between 60" [1524 mm] and 72" [1839 mm].

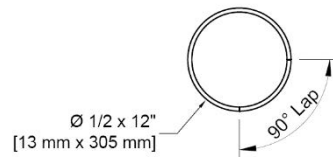
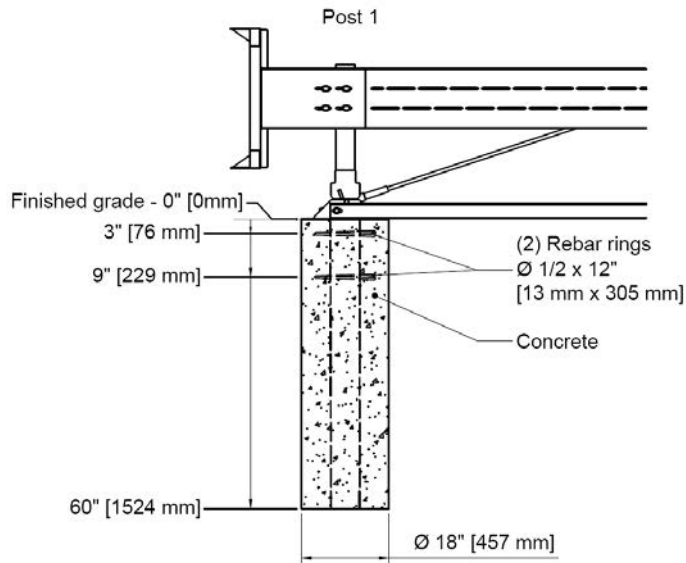

Grade 60 Ø 1/2 x 12" [13 mm x 305 mm] Rebar ring



For more complete information on Valtir products and services, visit us on the web at [www.valtir.com](http://www.valtir.com). Materials and specifications are subject to change without notice. Please contact Valtir to confirm that you are referring to the most current instructions.

**[WWW.VALTIR.COM](http://WWW.VALTIR.COM)**  
**1.888.356.2363**