

GENERAL NOTES

1. The energy absorbing system represented on this drawing is a proprietary design by Trinity Industries, Inc. and marketed under the trade name C-A-T 350, short for Crash Cushion/Attenuating Terminal. Any infringement on the rights of the designer shall be the sole responsibility of the user.
2. This drawing is produced by the Florida Department Of Transportation solely for use by the Department and its assignees. This standard drawing provides the general graphics and information necessary to field identify component parts of the C-A-T 350 system and their incorporation into a whole system.
3. This drawing is sufficient for plan details for the C-A-T 350 system installed in connection with standard single and double faced W-beam guardrail systems, and precludes the requirement for shop drawing submittals unless the plans otherwise call for such submittals.
4. The C-A-T 350 system shall be assembled and installed in accordance with the manufacturer's detailed drawings, procedures and specifications.
5. The C-A-T 350 system is suitable for speeds ≤ 60 mph.
6. The C-A-T 350 system shall be located on slopes of 1:10 or flatter and not closer than 11' to any traffic lane.
7. The 'tail end' section represented on this drawing applies to connections with single and double faced guardrail. The cable anchorage at Post No. 6 is to be used with single faced guardrail connections only.

Where the C-A-T 350 system is installed in conjunction with a rigid structure, a guardrail transition section shall be constructed between the C-A-T 350 system and the structure connection. The transition sections shown on Indexes 400 and 410 shall be constructed for connected to bridge concrete traffic rails and roadway concrete barrier walls; transition sections for connections to other rigid structures shall be as detailed in the plans and/or as approved by shop drawings.

8. For galvanizing requirements of metallic components see Standard Specification Section 967.
9. A yellow Type I Object Marker shall be centered 3' in front of the nose of the C-A-T 350 system. Mounting hardware shall be in conformance with Index No. 11860 and 11865. The cost of the Object Marker shall be included in the cost of the C-A-T 350.
10. The C-A-T 350 system for single and double faced guardrail applications will be paid for the under the contract unit price for Vehicular Impact Attenuator / Crash Cushion (CAT), EA.

DESIGN NOTES AND GUIDELINES

1. The C-A-T 350 system is designed to cushion automobile end-on hits and to redirect automobiles from side hits when impacting at speeds up to and including 60 mph. The C-A-T 350 system has a singular design for all speeds of 60 mph or less, and any adjustment to its design will not be permitted except as authorized by the manufacturer.
2. The C-A-T 350 system is not intended for use in gores of freeway and expressway mainline ramp terminals; gores of roadway forks; or other gore locations where there is a history of high frequency vehicle departure from the roadway or the potential exists for such departures. The C-A-T 350 system is not a restorable design and therefore requires complete replacement after having sustained either an end-on or a side vehicular impact. Deformed side rail elements that will inhibit the shearing of lands between the rail slots will be subfunctional and are to be replaced immediately; deformed elements are not to be refurbished for reuse.
3. Currently the Department does not recognize other proprietary items as being equally suitable alternatives to the C-A-T 350, and until such alternatives are available, the C-A-T 350 need not be bid against other proprietary items.

FDOT APPROVED DRAWING	
CAT-350	
Sheet No.	1 of 2
QPL No. S536-0213	

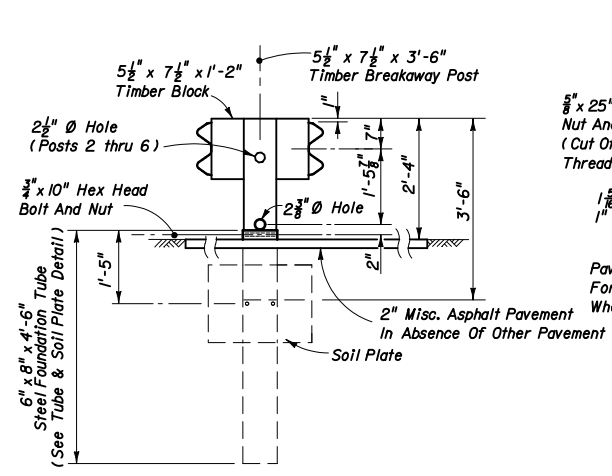

TYPICAL DIMENSIONING

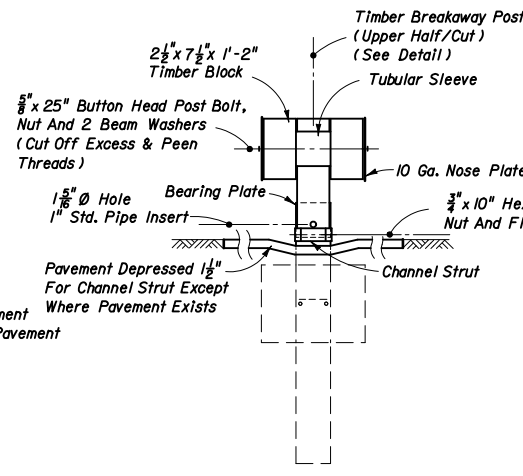

SECTION AA
POST NO. 1

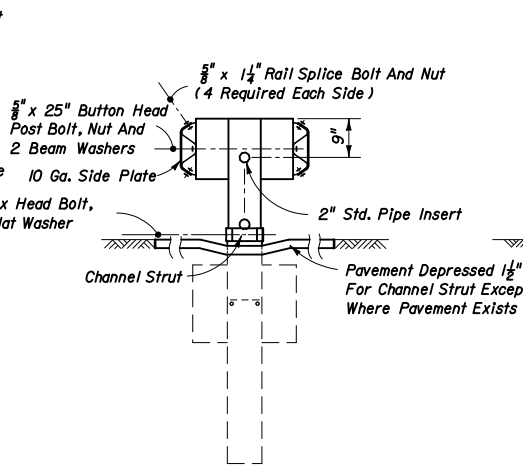

SECTION BB
POST NO. 2

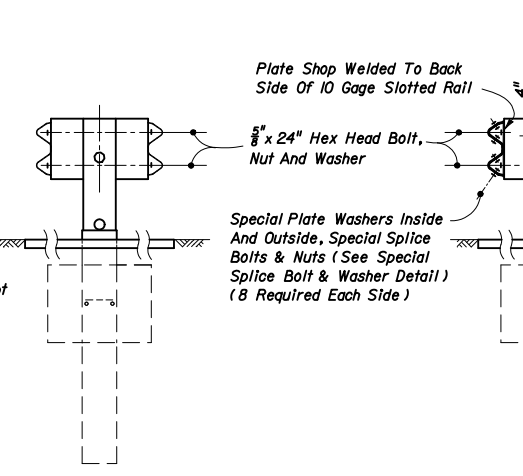

SECTION CC
POST 3 & 5

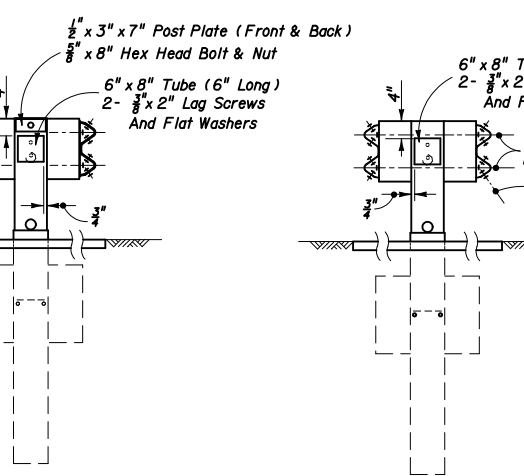

SECTION DD
POST NO. 4

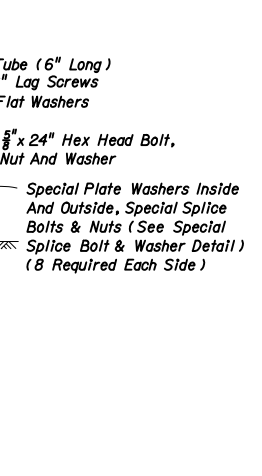

SECTION EE
POST NO. 6

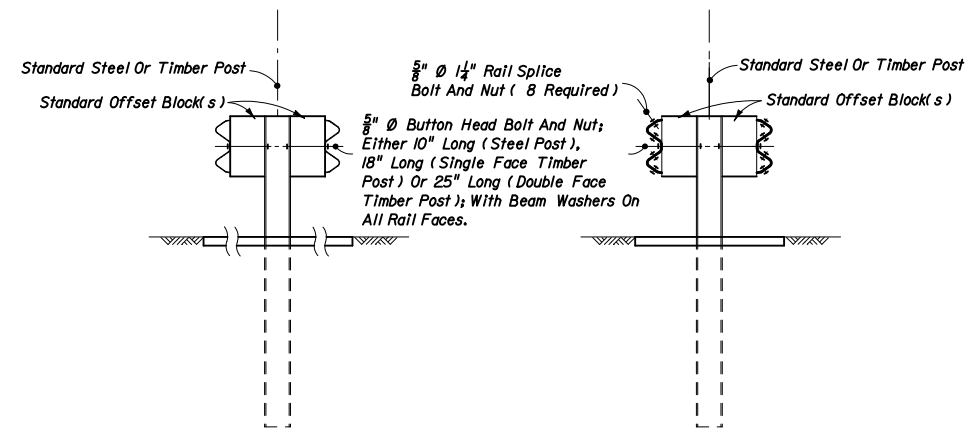

SECTION FF
POST NO. 7

SECTION GG
POST NO. 8

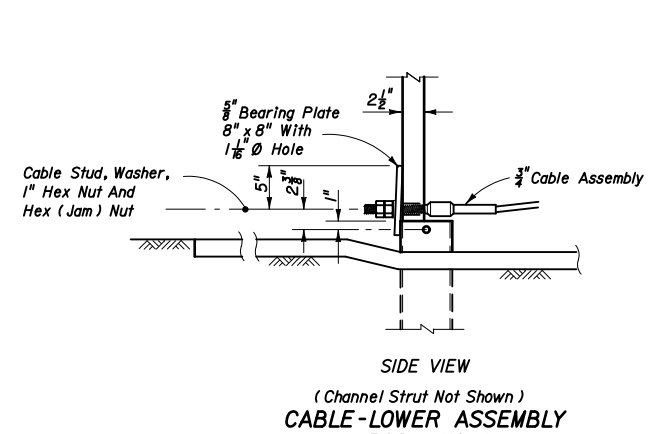

SIDE VIEW
(Channel Strut Not Shown)
CABLE-LOWER ASSEMBLY
POST NO. 1

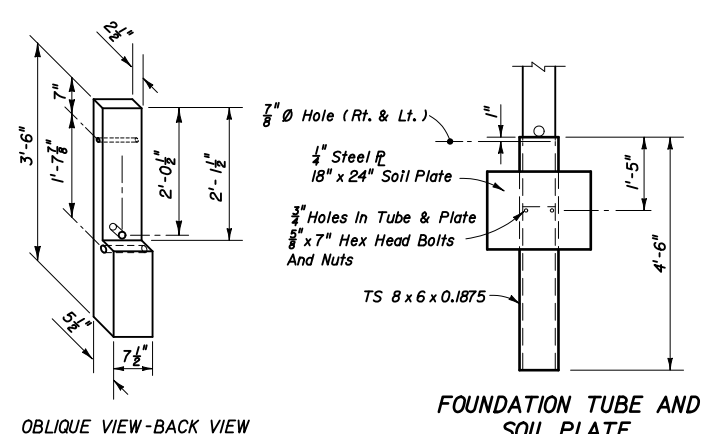

OBLIQUE VIEW-BACK VIEW
POST NO. 1

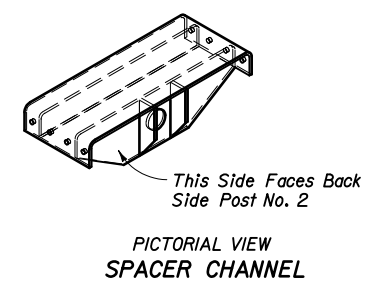

PICTORIAL VIEW
SPACER CHANNEL

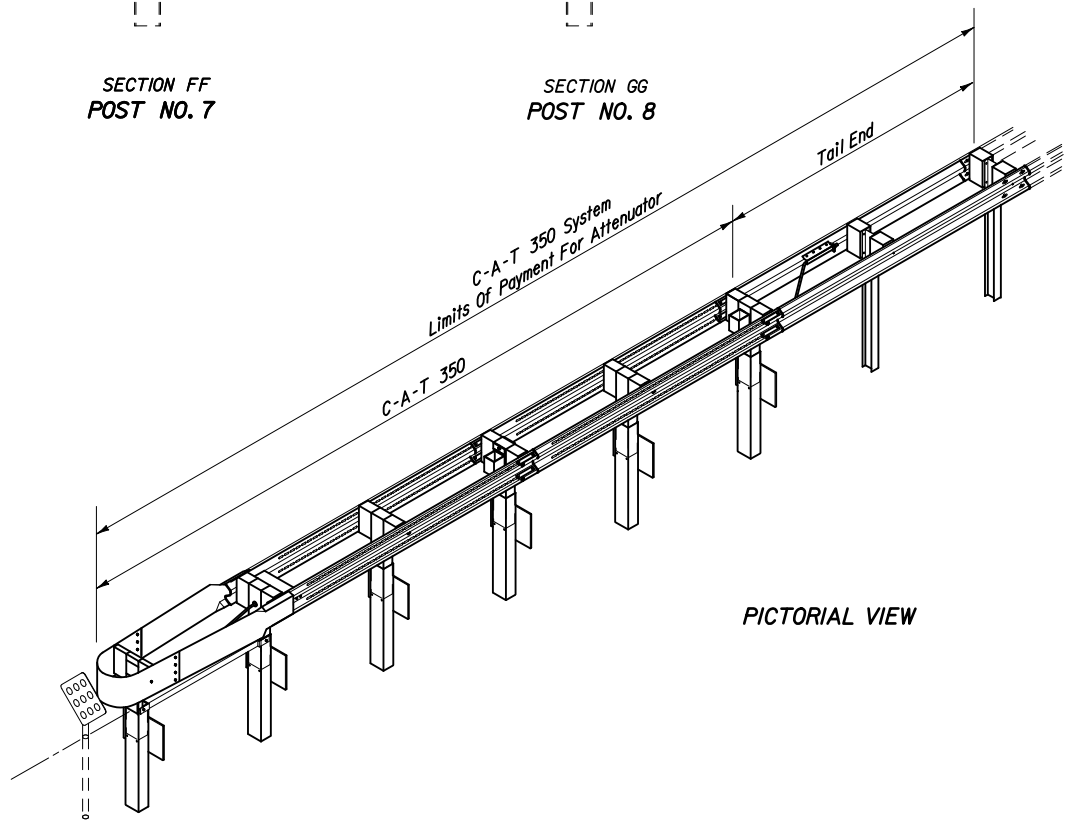

PICTORIAL VIEW

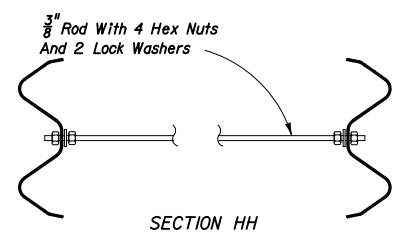

SECTION HH
BUCKLING RESTRAINT ROD

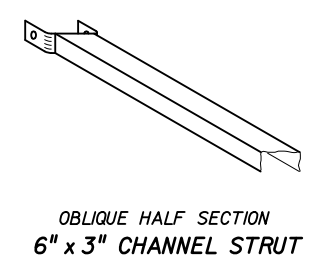

OBLIQUE HALF SECTION
6" x 3" CHANNEL STRUT

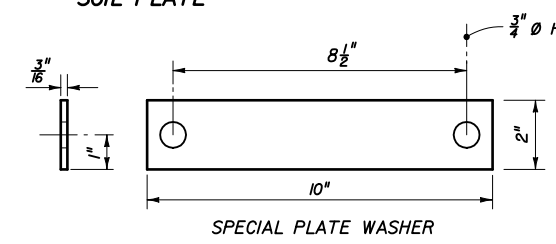

SPECIAL PLATE WASHER

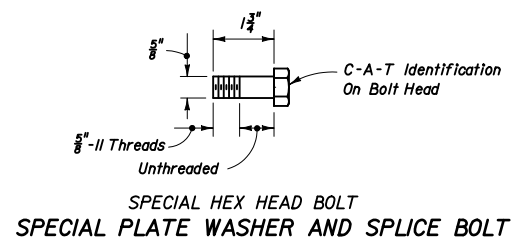

SPECIAL HEX HEAD BOLT
SPECIAL PLATE WASHER AND SPLICE BOLT

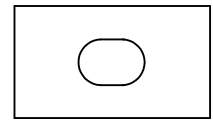

See Index 400 For Details
BEAM WASHER

FDOT APPROVED DRAWING	
CAT-350	
Sheet No. 2 of 2	QPL No. S536-0213