



4F-T™ SYSTEM

4 Foot Flared TREND® Terminal

PRODUCT MANUAL



PN 628615

JUNE 2024

4F-T™ System

4 Foot Flared TREND® Terminal

The 4 Foot Flared TREND® (4F-T™) Terminal system has been tested pursuant to American Association of State Highway and Transportation Officials (AASHTO) Manual for Assessing Safety Hardware (MASH) specifications. The 4F-T™ system has been submitted for Federal-aid reimbursement eligibility on the National Highway System to the Federal Highway Administration (FHWA).

Product Manual



15601 Dallas Parkway
Suite 525
Addison, Texas 75001



The local highway authority, distributors, owners, contractors, lessors, and lessees are RESPONSIBLE for the assembly, maintenance, and repair of the 4F-T™ System. Failure to fulfill these RESPONSIBILITIES with respect to the proper assembly, maintenance, and repair of the 4F-T™ system could result in serious injury and/or death.



These instructions are for standard assembly specified by the appropriate highway authority. In the event the specified system assembly, maintenance, or repair would require a deviation from standard assembly parameters, contact a Valtir representative.

This manual must be available to the worker(s) overseeing and/or assembling the product at all times. For additional copies, contact Valtir at (888) 356-2363 or visit www.Valtir.com.

The instructions contained in the manual supersede all previous information and manuals. All information, illustrations, and specifications in this manual are based on the latest 4F-T™ system information available to Valtir at the time of printing. Valtir reserves the right to make changes at any time. Please visit www.Valtir.com to confirm that you are referring to the most current revision.

TABLE OF CONTENTS

Customer Service Contacts	1
Safety Symbols	2
Safety Rules for Assembly	2
Limitations and Warnings.	3
System Overview	4
Recommended Tools	5
Site Preparation	6
Components	8
Assembly Steps	14
Step 1A: Post Layout For Right Side Application.	15
Step 1B: Post Layout For Left Side Application	16
Step 2: Assemble SYTP® (Posts 4-9)	17
Step 3: Assemble SYTP® With Soil Plate (Posts 2-3)	18
Step 4: Assemble 4F-T™ HBA® Post 1 Bottom With Soil Plate (Post 1)	19
Step 5: Assemble 4F-T™ HBA® Post 1 Top To HBA® Post 1 Bottom.	20
Step 6: Assemble 4F-T™ Formed Ground Strut	21
Step 7A: Assemble 4F-T™ 10 ga System Transition	22
Step 7B: Assemble 4F-T™ 10 ga System Rail Panel At SYTP® Locations 9-8	23
Step 7C: Assemble 4F-T™ 10 ga System Rail Panel At SYTP® Locations 8-7	24
Step 8: Assemble 4F-T™ 10 ga System Rail Panels / 4F-T™ (Posts 9-8)	25
Step 9: Assemble 4F-T™ Spacer Block To Posts 1 (HBA®) And 7-3 (SYTP®).	26
Step 10: Assemble 4F-T™ Anchor Spacer Block To SYTP® 2	27
Step 11: Assemble 4F-T™ 10 ga System Rail To SYTP® 7-2	28
Step 12: Assemble 4F-T™ 10 ga System Rail And 4F-T™ Head Rail Assembly	29
Step 13: Assemble the 4F-T™ Cable Assembly To Posts 1 And 2	30
Step 14: Assemble the Delineation To 4F-T™ Impact Head Assembly.	31
Step 15: Assemble the 4F-T™ Impact Head Assembly	32
Step 16: 4F-T™ Bolt Tightening/Torquing And Anchor Cable Tensioning	33
4F-T™ Assembly/Repair Checklist	34
4F-T™ Routine Inspection Checklist	35
Appendix A: Grading Detail	36
Appendix B: Alternative Footings Detail	37

Customer Service Contacts

Valtir is committed to the highest level of customer service. Feedback regarding the 4F-T™ system assembly procedures, supporting documentation, and performance is always welcome. Additional information can be obtained from the contacts below:

Valtir

Telephone:

(888) 356-2363

+1 (214) 589-8140 (International)

Internet:

www.Valtir.com/contact

Abbreviations and Acronyms

4F-T™ 4 Foot Flared TREND® Terminal

AASHTO American Association of State Highway and Transportation Officials

CFR Code of Federal Regulation

FHWA Federal Highway Administration

HBA® Hinged Breakaway Post

MASH Manual for Assessing Safety Hardware 2nd Edition Published in 2016 (2020 Errata)

MGS Midwest Guardrail System

MUTCD Manual on Uniform Traffic Control Devices

NCHRP National Cooperative Highway Research Program

NHS National Highway System

Nm Newton-Meters

OSHA Occupational Safety & Health Administration

PPE Personal Protective Equipment

SYTP® Steel Yielding Terminal Post

TL-3 Test Level-3

Valtir Valtir, LLC

Safety Symbols

This section describes safety symbols that may appear in this product manual. Read this manual for complete safety, assembly, operating, maintenance, repair, and service information.



Indicates Danger or Warning. Failure to read and follow this warning could result in serious injury or death to the workers and/or bystanders.



Indicates Caution or High Importance. Failure to follow this warning can result in improper performance, failure of operation, and/or serious injury or death in the event of a vehicle impact with the system.



Indicates Notifications or Reference. These denote important items but will not cause system damage or serious injury.



Indicates importance of reading instructions. Failure to follow all steps can result in improper performance, system failure, and/or serious injury or death in the event of a vehicle impact with the system.

Safety Rules for Assembly

This manual must be kept in a location where it is readily available to persons who are skilled and experienced in the proper assembly, maintenance, or repair of the 4F-T™ System. Additional copies of this manual are available from Valtir. Please contact Valtir if you have any questions concerning the information in this manual.



It is the responsibility of the installer to use proper safety precautions when operating power equipment and when moving heavy equipment or system components. Hand, eye, foot, and back protection is recommended.



Ensure that all of the Danger, Warning, Caution, and Important statements within this product manual are completely followed. Failure to follow this warning could result in serious injury or death in the event of a vehicle impact with the system.



DO NOT use any component part that has not been specified and/or approved for this system during assembly or repair.

Limitations and Warnings

Valtir, in compliance with AASHTO MASH, contracts with ISO 17025 A2LA accredited testing laboratories to perform crash tests, evaluate tests, and submit the test results to the FHWA for review.

4F-T™ System was tested to MASH-2nd Edition (2016), with 2020 Errata TL-3 criteria and may be used in Test Level 1, Test Level 2, and Test Level 3 applications – when installed at the full Test Level 3 system length of 34'-4 1/2" [10.48 m]. These tests typically evaluate product performance defined by MASH involving specific vehicles on roadways, lightweight cars (approximately 2,420 lb [1,100 kg]) and full size pickup trucks (approximately 5,000 lb [2,270 kg]) at 62 mph [100 kph].

The 4F-T™ System is tested pursuant to the test matrix criteria of MASH as designated by AASHTO and FHWA. The FHWA/AASHTO tests are not intended to represent the performance of systems when impacted by every vehicle type or in every impact condition existing on the roadway. Every departure from the roadway is a unique event.

Valtir expressly disclaims any warranty or liability for injury or damage to persons or property resulting from any impact, collision or harmful contact with its products, other vehicles, or nearby hazards or objects by any vehicle, object or person, whether or not the products were assembled in consultation with Valtir or by third parties.

The 4F-T™ System is intended to be assembled, delineated, and maintained within the state/specifying agency and federal guidelines. It is important for the state/specifying agency to select the most appropriate product configuration for its site specifications.

The state/specifying agency's evaluation of the site layout, vehicle population type and speed, traffic direction, and visibility are some of the elements that require evaluation in the selection of a highway product. For example, curbs could cause an untested effect on an impacting vehicle.

After an impact with the system, debris must be removed from the area immediately in compliance with the most applicable state/specifying agency policy and/or guidance. The specified 4F-T™ System must be evaluated and restored to its original specified condition or replaced as the state/specifying agency determines/requires, as soon as possible. Product selection, approval, proper installation, and maintenance of any highway product is the sole responsibility of the state/specifying agency.

Under NO circumstances shall the rail within the 4F-T™ System be curved between Post 1 and Post 9.

All metric dimensions are “soft conversions” and as such should be considered as reference only.



Safety Alert Symbols appear throughout this manual and indicate Danger, Warning, Caution or Important statements. Failure to read and follow these warnings could result in serious injury or death in the event of a vehicle impact with the system.

WARNING: Do not assemble, maintain, or repair the 4F-T™ System until you have read this manual thoroughly and completely understand it. Ensure that all Danger, Warning, Caution, and Important statements within the manual are completely followed. Please call Valtir at (888) 356-2363 if you do not understand any portion of these instructions or this manual.

WARNING: Safety measures incorporating appropriate traffic control devices and PPE specified by the state/specifying agency must be used to protect all personnel while at the assembly, maintenance, or repair site. Work gloves, eye protection, safety-toe shoes, and back protection shall be used.

WARNING: Ensure that the assembly site meets all appropriate MUTCD and the state/specifying agency standards.

WARNING: Use only Valtir parts that are specified by Valtir for use with the 4F-T™ System for assembling, maintaining, or repairing the 4F-T™ System. Do not utilize or otherwise commingle parts from other systems, even if those systems are other Valtir systems. Such configurations have not been tested, nor have they been approved for use. Assembly, maintenance, or repairs using unspecified parts or accessories is strictly prohibited. Failure to follow this warning could result in serious injury or death in the event of a vehicle impact with such an UNACCEPTED system.

WARNING: Do NOT modify the 4F-T™ System in any way.

IMPORTANT: Valtir makes no recommendation whether use or reuse of any part of the 4F-T™ System is appropriate or acceptable after impact. It is the responsibility of the state/specifying agency and its engineers to make that determination.

IMPORTANT: It is the responsibility of owner, state/specifying agency, or specifier to inspect the 4F-T™ System after assembly is complete to ensure the instructions provided in this manual have been strictly followed.

System Overview

The 4F-T™ System is a flared, single-sided, energy-absorbing, redirective and gating end terminal system. The system is the first four foot flared end terminal to meet the evaluation criteria set forth in AASHTO MASH. The system may be used to terminate strong post W-beam guardrail with mounting heights measuring 27 3/4" [705 mm] to 31" [787 mm] utilizing a state/specifying agency approved transition.

The 4F-T™ System consists of one (1) 4F-T™ Impact Head, eight (8) 4F-T™ 10 ga System Rail, one (1) HBA® Post with Soil Plate at post location 1, eight (8) SYTP® at post locations 2-9, one (1) 4F-T™ 10 ga System Transition Panel, eight (8) 4F-T™ Steel Spacer Blocks, one (1) 4F-T™ Anchor Spacer Block, eight (8) 4F-T™ Backing Plates, one (1) 4F-T™ Formed Ground Strut, one (1) 4F-T™ Cable Assembly, Soil Plates at posts 2 & 3, and various other fastener and hardware components.

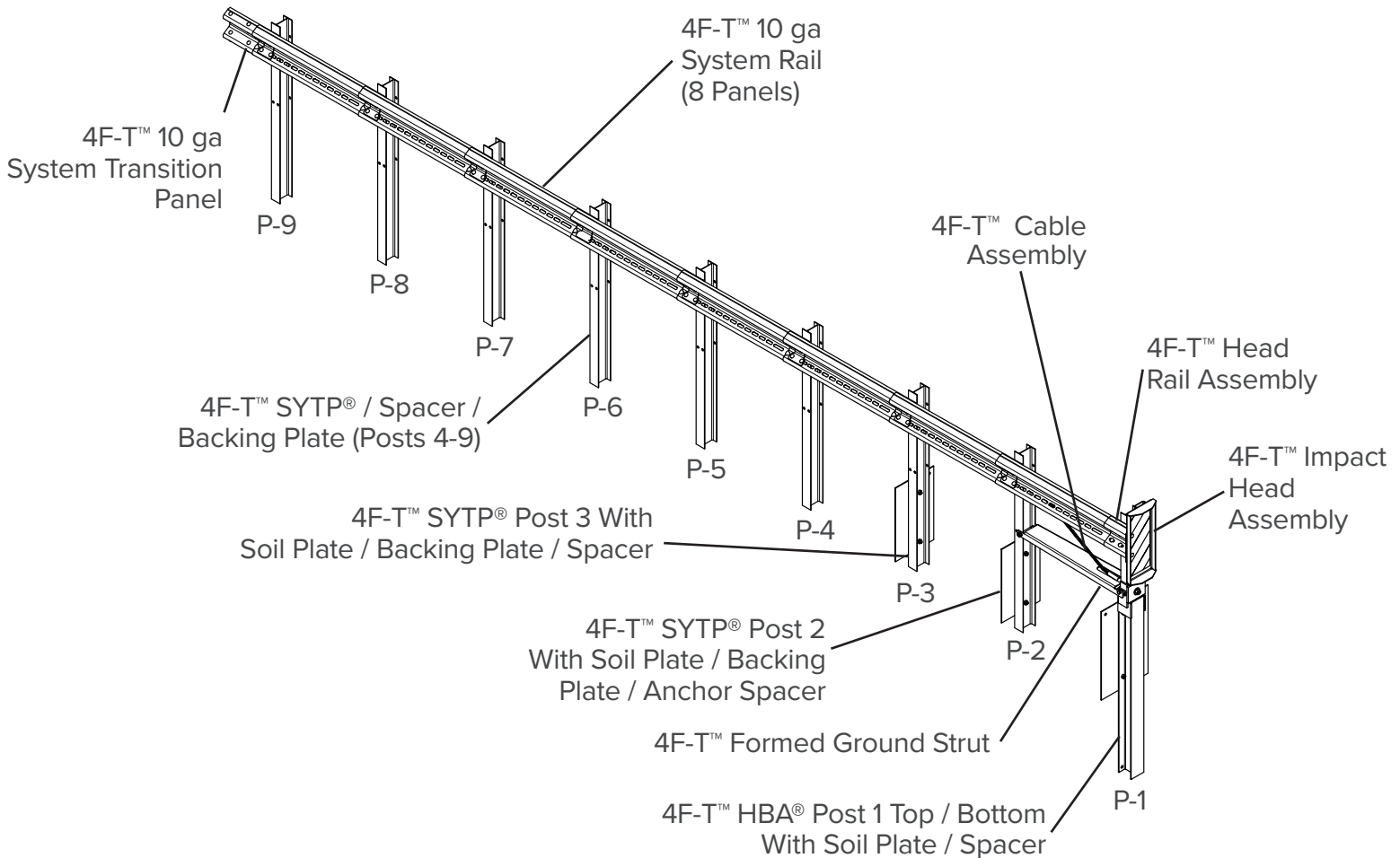

Reference Drawing: SS 4380

Recommended Tools

Documentation

- Assembly Manual (Current Version)
- System Drawing SS 4380 (Current Version)
- 4F-T™ Transition Drawings: SS 4381, SS 4382 (Current Version)

Personal Protective Equipment (PPE)

- Eye Protection
- Work Gloves
- Safety-Toe Shoes
- Hard Hat

Miscellaneous

- Traffic Control Equipment and Plan per state/specifying agency standards and the MUTCD
- SAE Combination Wrench Set
- Socket Set & Socket Wrench
- Hammer
- Chalk Line
- Tape Measure
- Marking Paint and Pen
- Straight Edge
- Level
- Plumb Line
- Post Pounder (commonly used for driving posts)
- Auger
- Soil Tamper
- 5/8" Alignment Tool (Drift Pin)
- Locking Pliers and/or pipe wrench
- Calibrated Torque Wrench (or other tool), capable of measuring 100 ft-lb [135 Nm], (+/- 5 ft-lb) [+/- 7 Nm]

Note: The provided list of tools is a general recommendation and should not be considered an exhaustive list. Depending on specific site conditions and the complexity of the assembly, the required tools may vary. Decisions as to what tools are needed to perform the job are entirely the responsibility of the state/specifying agency and the selected contractor performing the assembly of the system at the state/specifying agency's site.

Site Preparation

The 4F-T™ System may be specified for use by the appropriate state/specifying agency in conjunction with strong post W-beam guardrail systems on the shoulder or median of a roadway. The decision to specify the system for a particular project is the responsibility of the state/specifying agency design engineer who must ensure that the most appropriate end terminal has been selected for the specific site conditions.

The 4F-T™ System is designed to be attached to strong post W-beam guardrail systems that have been accepted under MASH or NCHRP Report 350 crash test criteria that use either no offset blocks, 8" [203 mm] offset blocks or 12" [305 mm] offset blocks. Some options may require transitions.



The 4F-T™ System must not be attached directly to a weak post W-beam guardrail system without an approved weak-post-to-strong-post transition plus a minimum of 12'-6" [3.81 m] strong post single-ply 12-gauge W-beam guardrail with 6'-3" [1.905 m] post spacing. The 12'-6" [3.81 m] strong post W-beam guardrail must be placed between the system and the weak-post-to-strong-post transition.



The 4F-T™ System must not be attached directly to Thrie Beam, Thrie Beam Transition, or to a post which is stronger/stiffer than a standard W-beam W6x8.5# [W150x13] or W6x9# [W150x13.5] guardrail post. A minimum of 9'-4 1/2" [2.858 m] strong post single-ply 12-gauge W-beam guardrail must be placed between the system and the Thrie Beam transition (or stronger/stiffer post).



Do not attach the 4F-T™ System directly to a rigid barrier (i.e. concrete barrier, wall or bridge pier) without the use of a state/specifying agency approved transition.



Valtir does not direct grading. Proper site grading must be accomplished before assembly of the 4F-T™ System in accordance with local specifying agency guidelines and/or the AASHTO Roadside Design Guide (see Appendix A), whichever is more stringent. Failure to follow this warning could result in serious injury or death in the event of a vehicle impact or collision.



The Beginning Length of Need ("BLON") for the 4F-T™ System was established during MASH Test 3-35 as Post 4, which is 12'-6" [3.81 m] from the center of Post 1.



A minimum of 50' [15.24m] of strong post W-beam guardrail with 6'-3" [1.905 m] post spacing, must be placed between "back-to-back" 4F-T™ Systems.



The 4F-T™ System can be aesthetically stained/treated, after Hot Dipped Galvanizing, with reactive color treatment. The 4F-T™ may NOT be powder coated or painted.



The 4F-T™ was tested to MASH-2nd Edition (2016), with 2020 Errata Test Level 3 criteria and may be used in Test Level 1, Test Level 2, and Test Level 3 applications - when installed at the full Test Level 3 system length of 34'-4 1/2" [10.477 m].



Under **NO** circumstances shall the rail within the 4F-T™ be curved, between Post 1 and Post 9. Ensure all 4F-T™ post spacings are 4'-2" [1.270 m] on center.

Offset Requirements Within A Curve



Utilizing a 4F-T™ on a tight convex/radius could cause the 4F-T™ to encroach onto the shoulder.

If the state/specifying agency has an established guidance or policy for the installation of flared guardrail end terminals, it should be followed.

Note: The AASHTO Roadside Design Guide, 4th Edition (2011) - Chapter 10 provides limited general guidance in regard to Roadside Safety in an Urban or Restricted Environments, which may be of use to the design engineer.

System Post Placement

The 4F-T™ System posts are inserted into the state/specifying agency approved “strong” soil using an auger or post pounding equipment used for placement. If an auger is used, ensure diameter is large enough to allow for proper compaction of state/specifying agency approved fill material. All system posts are to be assembled within established standard construction tolerances, including being reasonably plumb. Compaction for all posts must be within the state/specifying agency guidelines.



It is the responsibility of the installer to ensure all above & below ground utilities as well as drainage structures are located, marked, and identified prior to using an auger or post pounding tool in accordance with state/specifying agency guidelines. Failure to follow this warning could result in serious injury or death.

Rigid Pavement and Underground Obstructions

If rigid pavement (e.g. concrete or asphalt) of **any thickness** is encountered within post locations 3-9, follow the state/specifying agency guidance or policy in regards to standard guardrail installation methods for such conditions. If a state/specifying agency does NOT have such guidance or policy, the 4F-T™ designer’s recommendation is to ensure a proper “leave-out” area (the specified size of open space as defined in the AASHTO Roadside Design Guide) and/or per the state/specifying agency is provided around the posts and filled with state/specifying agency approved backfill material.

If solid rock is encountered at post locations 3-9, refer to the state/specifying agency guidelines and/or the AASHTO Roadside Design Guide for requirements for embedment depth in the rock and size of the hole. If solid rock is encountered at post locations 1-2, auger a hole in the rock large enough for full post embedment and proper compaction of state/specifying agency approved backfill material.

For alternate footing designs when encountering rock/underground obstructions for post location 1, see Appendix B for guidance.



Drilling Holes Into Rock: It is the responsibility of the installer to consult OSHA silica respiratory standard 29 CFR 1910.134 for debris removal and ensure compliance.

Inspect Shipment

Before assembling the 4F-T™ System, carefully unpack and inspect all components for signs of damage. Check the received parts against the packing list supplied with the system to verify that all parts were received. If parts are damaged or missing from the shipment or unspecified, do **NOT** attempt to assemble the system; contact Valtir immediately.



Components

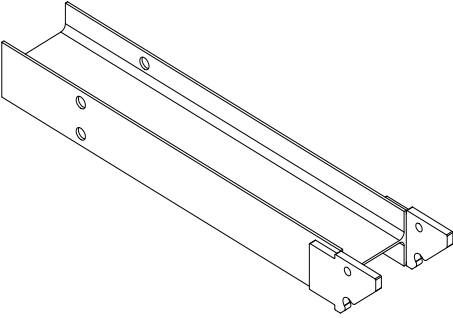
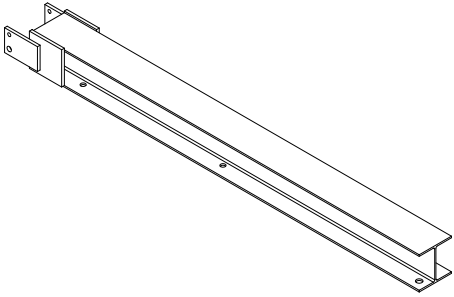
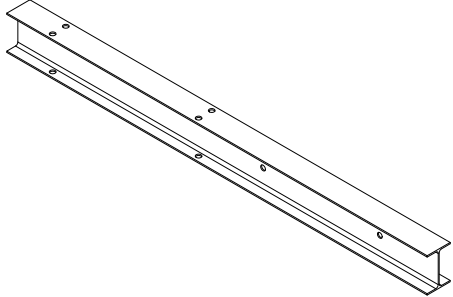
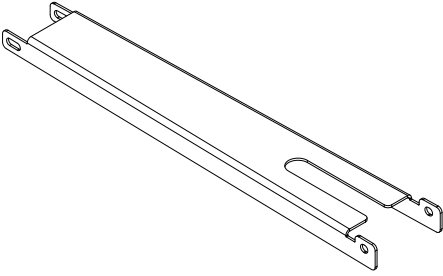
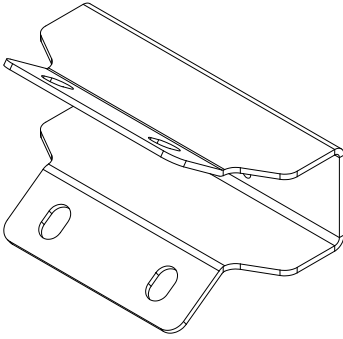
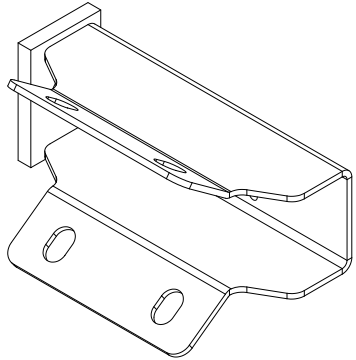
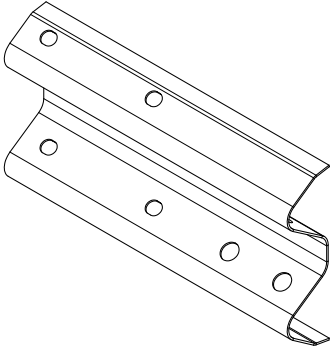
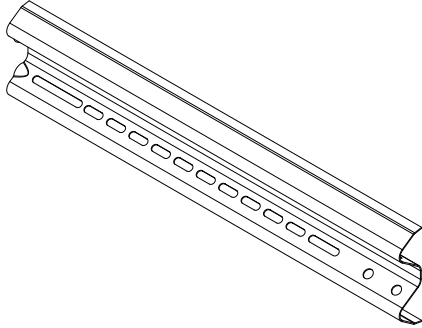
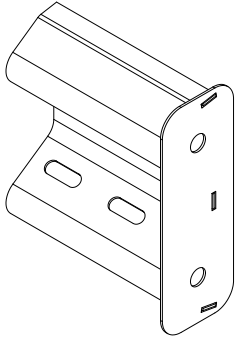

Below is a pictorial depiction of the components/hardware for 4F-T™. Please see the Valtir drawings and page 12 of this manual for specific lists of components/hardware and quantities required for the 4F-T™.

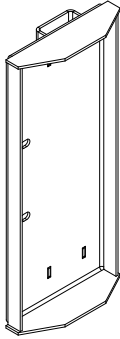
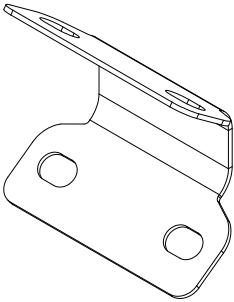
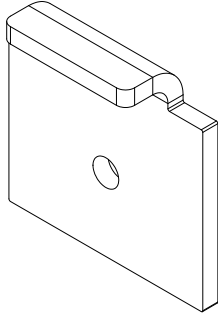
Note: The following components/hardware are not shown to scale:

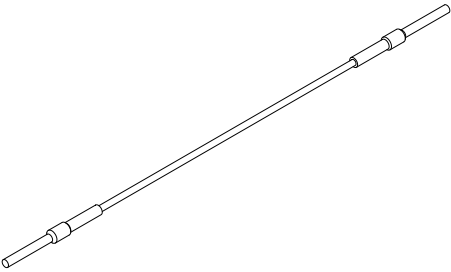
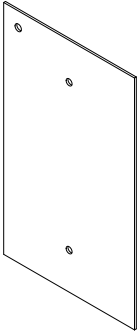
ID: A PN: 628553G	ID: B PN: 628554G	ID: C PN: 627379G
		
4F-T™ HBA® Post 1 Top	4F-T™ HBA® Post 1 Bottom	4F-T™ SYTP® W/Soil Plate Hole
ID: D PN: 627380G	ID: E PN: 628540G	ID: F PN: 628555G
		
4F-T™ Formed Ground Strut	4F-T™ Spacer Block	4F-T™ Anchor Spacer Block
ID: G PN: 628542G	ID: H PN: 628543G	ID: I PN: 628556G
		
4F-T™ 10 ga System Transition Panel	4F-T™ 10 ga System Rail	4F-T™ Head Rail Assy

ID: J	PN: 628557B	ID: K	PN: 628548G	ID: L	PN: 628549G
					
4F-T™ Impact Head Assy		4F-T™ Backing Plate		4F-T™ Bearing Plate	

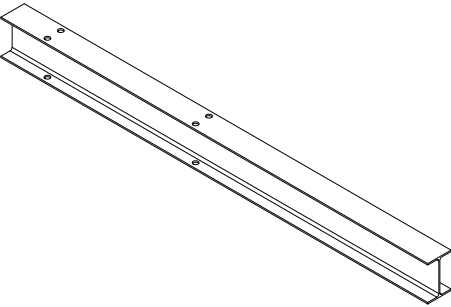
ID: M	PN: 119595G	ID: N	PN: 628551G	ID: O	PN: 628550G
					
4F-T™ Cable Assembly 3/4" x 5'-10" [19 mm x 1.778 m]		4F-T™ Soil Plate Post 2 & 3		4F-T™ Soil Plate Post 1	

ID: P	PN: 15000G	ID: R1	PN: 105378B	ID: R2	PN: 105377B
					
SYTP Post 6'-0" [1.83 m]		Right Reflective Sheeting 10" x 25" [254 mm x 635 mm]		Left Reflective Sheeting 10" x 25" [254 mm x 635 mm]	

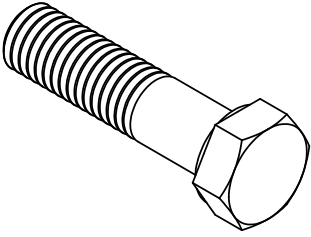
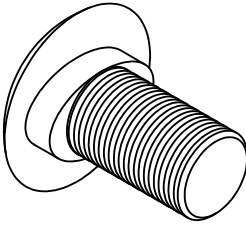
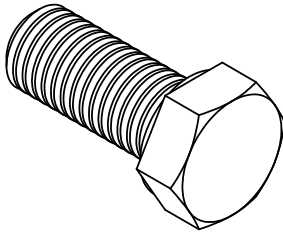
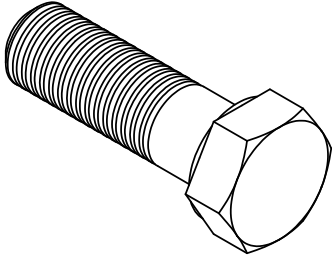
ID: B1	PN: 113473G	ID: B2	PN: 3360G	ID: B3	PN: 113654G	ID: B4	PN: 3403G
							
1/2" x 2" Hex Bolt Grade 5 [13 mm x 50 mm]		5/8" x 1 1/4" GR Bolt [16 mm x 31 mm]		5/8" x 1 1/2" Hex Bolt Grade 5 [16 mm x 38 mm]		5/8" x 2" Hex Bolt [16 mm x 50 mm]	

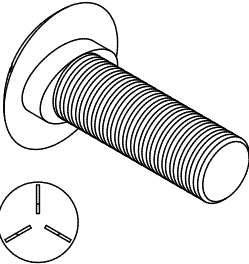
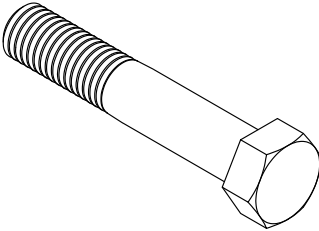
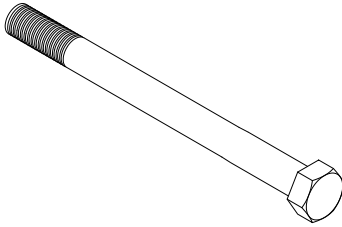
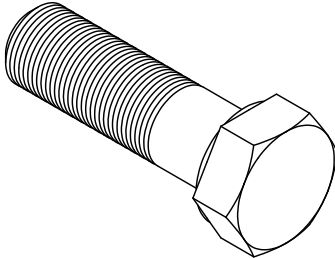
ID: B5	PN: 118614G	ID: B6	PN: 113660G	ID: B7	PN: 3479G	ID: B8	PN: 3717G
							
5/8" x 2" GR Bolt Grade 5 (A325) [16 mm x 50 mm]		5/8" x 3 1/2" Hex Bolt Grade 5 [16 mm x 90 mm]		5/8" x 7 1/2" Hex Bolt A325 [16 mm x 191 mm]		3/4" x 2 1/2" Hex Bolt A325 [19 mm x 64 mm]	

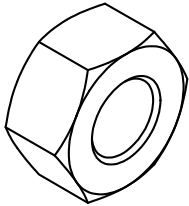
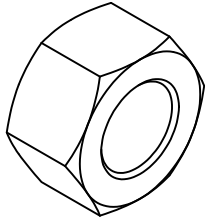
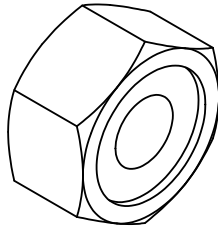
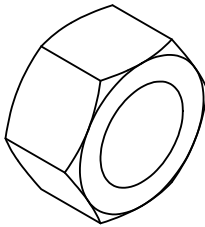
ID: N1	PN: 3279G	ID: N2	PN: 3361G	ID: N3	PN: 3340G	ID: N4	PN: 3704G
							
1/2" Heavy Hex Nut A563 [13 mm]		5/8" Heavy Hex Nut A563 [16 mm]		5/8" GR Hex Nut [16 mm]		3/4" Heavy Hex Nut A563 [19 mm]	

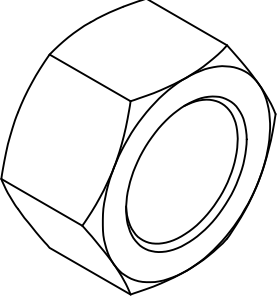
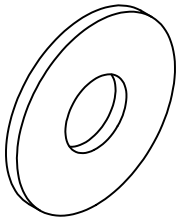
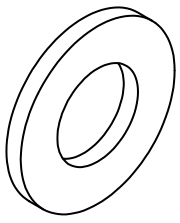
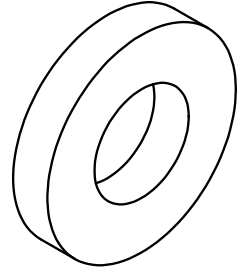
ID: N5	PN: 3910G	ID: W1	PN: 118009G	ID: W2	PN: 4372G	ID: W3	PN: 118615G
							
1" Heavy Hex Nut A563 [25 mm]		1/2" Flat Washer [13 mm]		5/8" Flat Washer [16 mm]		5/8" Flat Washer (1/4" Thick) [16 mm] [6 mm thick]	

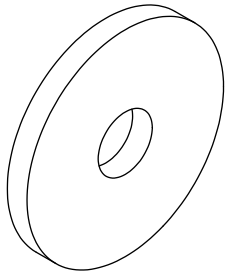
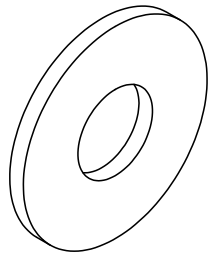
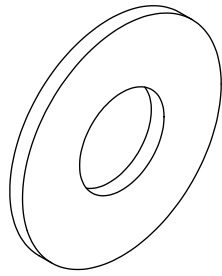
ID: W4	PN: 119692G	ID: W5	PN: 3700G	ID: W6	PN: 3900G
					
5/8" x 2-1/2" OD Washer [16 mm x 64 mm]		3/4" Round Washer [19 mm]		1" Round Washer [25 mm]	

ID	4F-T™ COMPONENTS/HARDWARE	PN	QTY
A	4F-T™ HBA® Post 1 Top	628553G	1
B	4F-T™ HBA® Post 1 Bottom	628554G	1
C	4F-T™ SYTP® With Soil Plate Holes Posts 2-3	627379G	2
D	4F-T™ Formed Ground Strut	627380G	1
E	4F-T™ Spacer Block	628540G	8
F	4F-T™ Anchor Spacer Block	628555G	1
G	4F-T™ 10 ga System Transition Panel	628542G	1
H	4F-T™ 10 ga System Rail	628543G	8
I	4F-T™ Head Rail Assembly	628556G	1
J	4F-T™ Impact Head Assembly	628557B	1
K	4F-T™ Backing Plate	628548G	8
L	4F-T™ Bearing Plate	628549G	1
M	4F-T™ Cable Assembly 3/4" x 5'-10" [19 mm x 1.778 m]	119595G	1
N	4F-T™ Soil PL, 1/4" x 18" x 30" [6 mm x 457 mm x 762 mm] for Posts 2-3	628551G	2
O	4F-T™ Soil PL, 1/4" x 22" x 36" [6 mm x 559 mm x 914 mm] for Post 1	628550G	1
P	SYTP® Post 6'-0" [1.83 mm]	15000G	6
B1	1/2" x 2" Hex Bolt Grade 5 [13 mm x 50 mm]	113473G	2
B2	5/8" x 1 1/4" GR Bolt [16 mm x 31 mm]	3360G	8
B3	5/8" x 1 1/2" Hex Bolt Grade 5 [16 mm x 38 mm]	113654G	4
B4	5/8" x 2" Hex Bolt [16 mm x 50 mm]	3403G	9
B5	5/8" x 2" GR Bolt Grade 5 (A325) [16 mm x 50 mm]	118614G	38
B6	5/8" x 3 1/2" Hex Bolt Grade 5 [16 mm x 90 mm]	113660G	4
B7	5/8" x 7 1/2" Hex Bolt A325 [16 mm x 191 mm]	3479G	1
B8	3/4" x 2 1/2" Hex Bolt A325 [19 mm x 64 mm]	3717G	2
N1	1/2" Heavy Hex Nut A563 [13 mm]	3279G	2
N2	5/8" Heavy Hex Nut A563 [16 mm]	3361G	38
N3	5/8" GR Hex Nut [16 mm]	3340G	26
N4	3/4" Heavy Hex Nut A563 [19 mm]	3704G	2
N5	1" Heavy Hex Nut A563 [25 mm]	3910G	2
W1	1/2" Flat Washer [13 mm]	118009G	2
W2	5/8" Flat Washer [16 mm]	4372G	10
W3	5/8" Flat Washer (1/4" Thick) [16 mm] [6 mm thick]	118615G	36
W4	5/8" x 2-1/2" OD Washer [16 mm x 64 mm]	119692G	2
W5	3/4" Round Washer [19 mm]	3700G	2
W6	1" Round Washer [25 mm]	3900G	2
	Optional Delineation Available From Valtir		
R1	10" x 25" [254 mm x 635 mm] Yellow/Black Reflector (Right Side)	105378B	1
R2	10" x 25" [254 mm x 635 mm] Yellow/Black Reflector (Left Side)	105377B	1

ID	4F-T™ HARDWARE BUCKET	627279B	1
	4F-T™ Hardware Bag 1 Soil Plate	627280B	1
B3	5/8" x 1 1/2" Hex Bolt Grade 5 [16 mm x 38 mm]	113654G	4
B6	5/8" x 3 1/2" Hex Bolt Grade 5 [16 mm x 90 mm]	113660G	4
N3	5/8" GR Hex Nut [16 mm]	3340G	8
	4F-T™ Hardware Bag 2 Post 1/Strut	627281B	1
B1	1/2" x 2" Hex Bolt Grade 5 [13 mm x 50 mm]	113473G	2
B7	5/8" x 7 1/2" Hex Bolt A325 [16 mm x 191 mm]	3479G	1
B8	3/4" x 2 1/2" Hex Bolt A325 [19 mm x 64 mm]	3717G	2
N1	1/2" Heavy Hex Nut A563 [13 mm]	3279G	2
N3	5/8" GR Hex Nut [16 mm]	3340G	1
N4	3/4" Heavy Hex Nut A563 [19 mm]	3704G	2
W1	1/2" Flat Washer [13 mm]	118009G	2
W2	5/8" Flat Washer [16 mm]	4372G	1
W5	3/4" Round Washer [19 mm]	3700G	2
	4F-T™ Hardware Bag 3 Rail/Spacer Block	627282B	1
B4	5/8" x 2" Hex Bolt [16 mm x 50 mm]	3403G	9
B5	5/8" x 2" GR Bolt Grade 5 (A325) [16 mm x 50 mm]	118614G	36
N2	5/8" Heavy Hex Nut A563 [16 mm]	3361G	36
N3	5/8" GR Hex Nut [16 mm]	3340G	9
W2	5/8" Flat Washer [16 mm]	4372G	9
W3	5/8" Flat Washer (1/4" Thick) [16 mm] [6 mm thick]	118615G	36
	4F-T™ Hardware Bag 4 Head/Cable	627283B	1
B5	5/8" x 2" GR Bolt Grade 5 (A325) [16 mm x 50 mm]	118614G	2
N2	5/8" Heavy Hex Nut A 563 [16 mm]	3361G	2
N5	1" Heavy Hex Nut A563 [25 mm]	3910G	2
W4	5/8" x 2-1/2" OD Washer [16 mm x 64 mm]	119692G	2
W6	1" Round Washer [25 mm]	3900G	2
	Loose Material		
B2	5/8" x 1 1/4" GR Bolt [16 mm x 31 mm]	3360G	8
N3	5/8" GR Hex Nut [16 mm]	3340G	8
Q	4 Foot Flared TREND® Terminal Product Manual	628615B	1
K	4F-T™ Backing Plate	628548G	8
L	4F-T™ Bearing Plate	628549G	1

Assembly Steps



To ensure an accurate assembly of the 4F-T™ System, it is recommended that steps be completed in order; however, some contractors have pre-assembled some steps. **ALL STEPS MUST BE COMPLETED.**



Below ground portions in some assembly steps are not shown for clarity. It is acceptable to weld the soil plates to the posts in Steps 3 and 4. After welding, wire brush the weld to remove loose slag, then apply a zinc rich paint, consistent with ASTM A780 or as instructed by state/specifying agency. In areas known for difficulty with below grade soils, washers (not included) may be added under the bolt head and/or the nut when installing the soil plates to posts, in Steps 3 and 4.



Indicates importance of reading instructions. Failure to follow all steps can result in improper performance, system failure, and/or serious injury or death in the event of a vehicle impact with the system.

System Guardrail Identification/Orientation

Note: The dimples and long slots in the 4F-T™ 10 ga System rail panel are always located **downstream**.

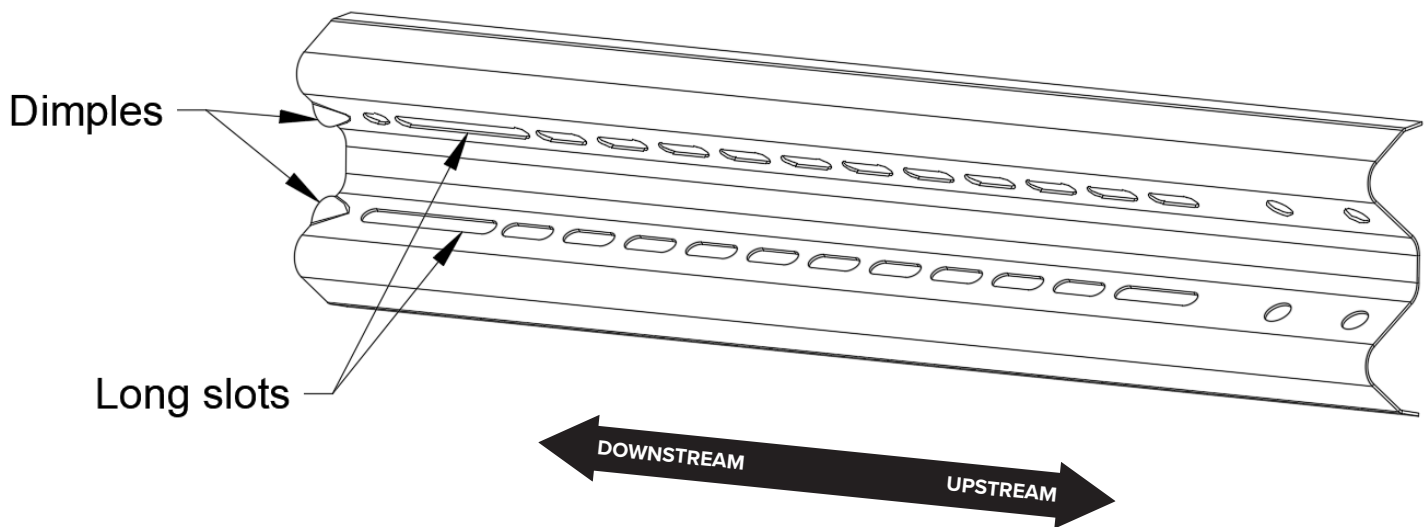

STEP 1A

POST LAYOUT FOR RIGHT SIDE APPLICATION

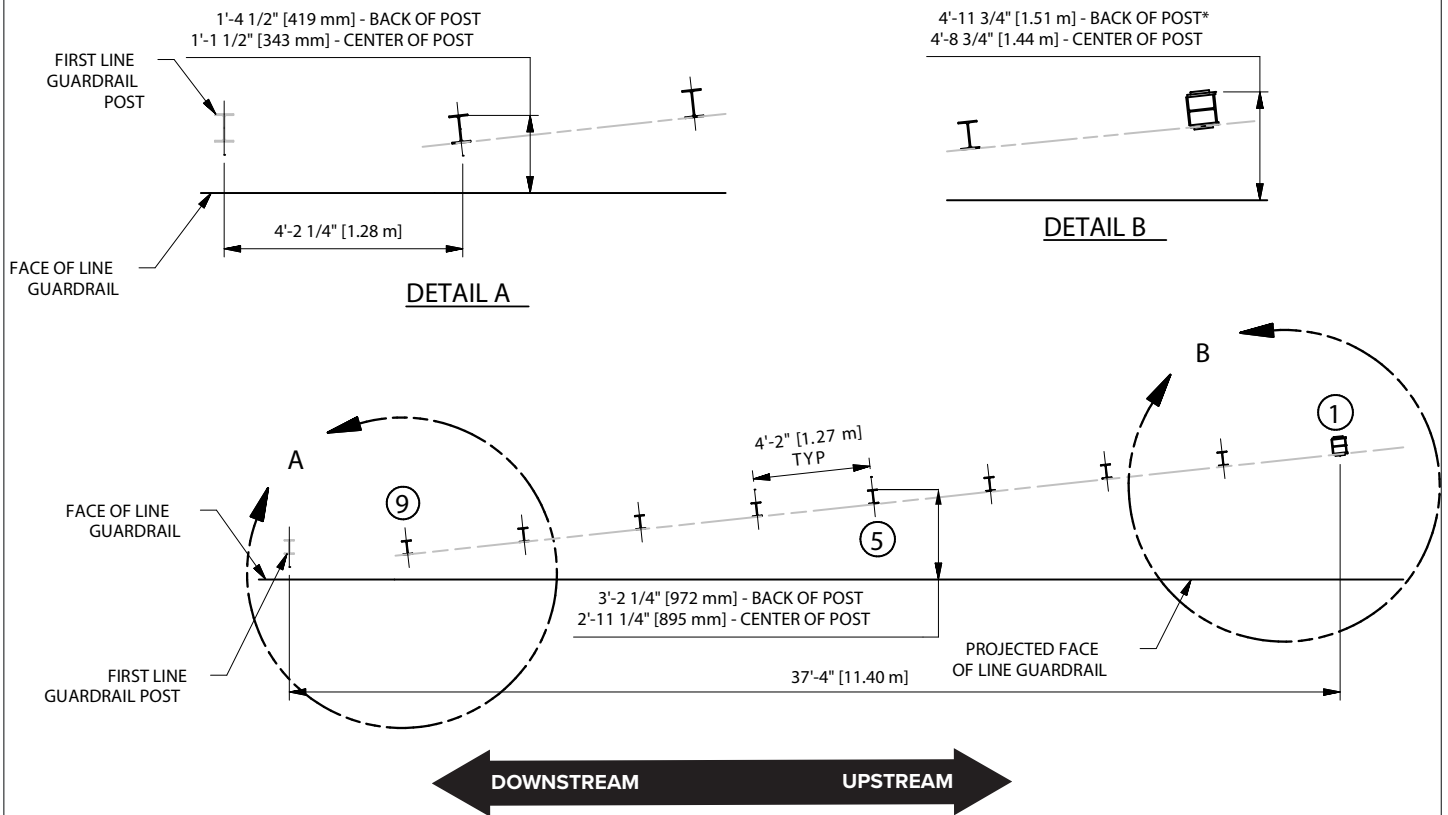

*Does not include welded plate

! INSTRUCTIONS !

1. Locate the 4F-T™ System post locations as shown in the above diagram.
2. Proper site grading must be accomplished in accordance with state/specifying agency guidelines and/or the AASHTO Roadside Design Guide, whichever is more stringent. Failure to follow this warning could result in serious injury or death in the event of a vehicle impact with the system.
3. Under **NO** circumstances shall the rail within the 4F-T™ be curved between Post 1 and Post 9. Ensure the 4F-T™ System Posts 1-9 locations are in a straight line.



STEP 1B

POST LAYOUT FOR LEFT SIDE APPLICATION

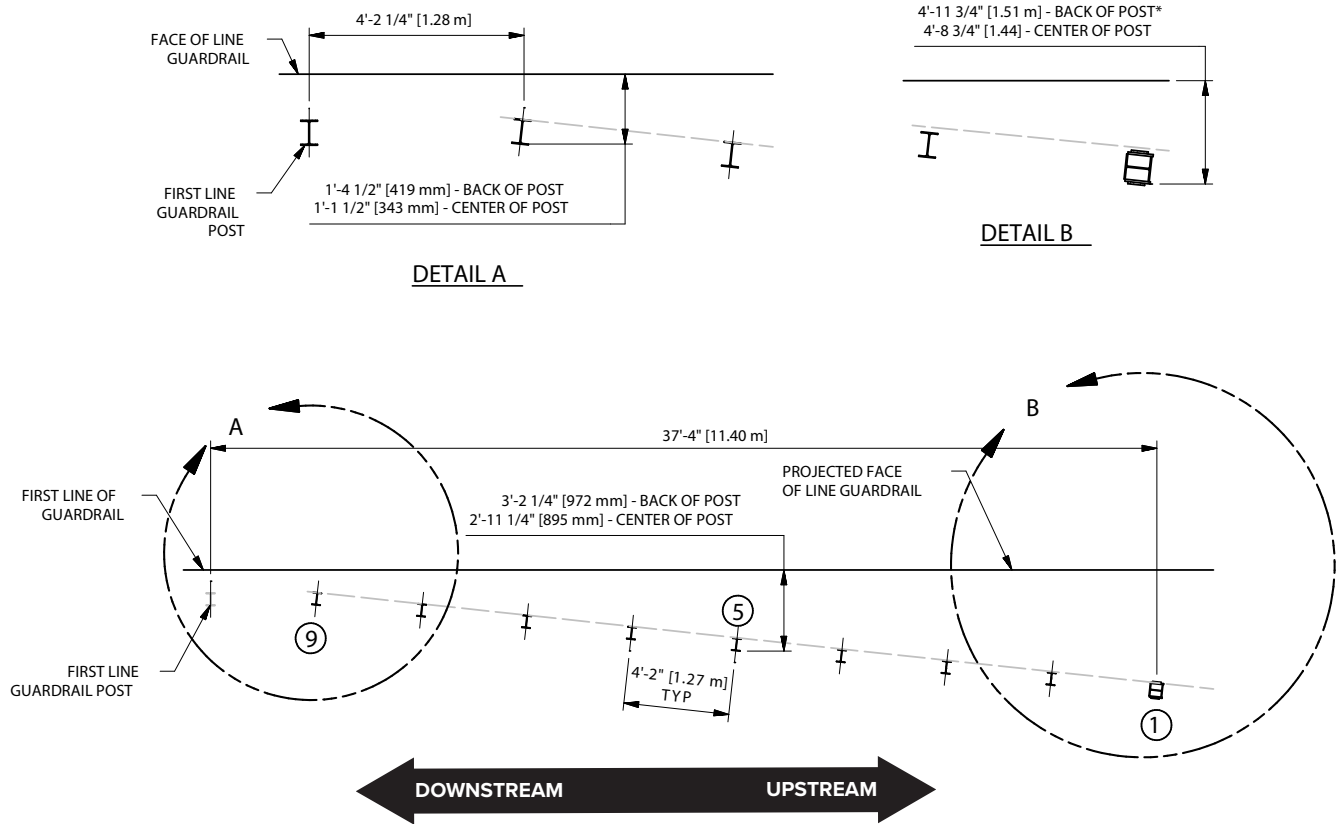

*Does not include welded plate

! INSTRUCTIONS !

1. Locate the 4F-T™ System post locations as shown in the above diagram.
2. Proper site grading must be accomplished in accordance with state/specifying agency guidelines and/or the AASHTO Roadside Design Guide, whichever is more stringent. Failure to follow this warning could result in serious injury or death in the event of a vehicle impact with the system.
3. Under **NO** circumstances shall the rail within the 4F-T™ be curved between Post 1 and Post 9. Ensure the 4F-T™ System Posts 1-9 locations are in a straight line.



4F-T™ Assembly/Repair Checklist

Performed by: _____

Date: _____

Location: _____

- 1. Ensure proper site grading complies with state/specifying agency guidelines and/or AASHTO Roadside Design Guide, whichever is more stringent. (p. 6)
- 2. Ensure required traffic control is in place to conduct 4F-T™ assembly.
- 3. Ensure only Valtir, LLC provided 4F-T™ parts are used for the assembly of the 4F-T™ and that all parts are free of damage. (p. 12)
- 4. Under **NO** circumstances shall the rail within the 4F-T™ be curved between Post 1 and Post 9. Ensure all 4F-T™ post spacings are 4'-2" [1.270 m] on center. (p. 16)
- 5. Ensure the soil around all posts is properly compacted. When leave outs are necessary, use only state/specifying agency approved backfill material within the leave out area. (pp. 12, 16)
- 6. Ensure Soil Plates are installed on the **downstream** side of Posts 1-3. (pp. 18, 19)
- 7. Ensure the 4F-T™ HBA® Post 1 Top and Bottom are oriented correctly with the 1/2" bolt holes located **upstream** of the 3/4" bolt holes. The portion of the 4F-T™ HBA® Bottom Post 1 is 1 3/4" [44 mm] (+1", -0") [+25 mm, -0 mm] above the finished grade. (p. 19).
- 8. Ensure the center of the SYTP® yielding holes at Posts 2-9 are approximately centered at finished grade. (pp. 17, 18)
- 9. Ensure the 4F-T™ Formed Ground Strut is attached to Post 1 & 2 and oriented correctly – the flat portion is **up** and cable positioning slot is **upstream**. (p. 20)
- 10. Ensure 4F-T™ Spacer Blocks (standard and anchor) are approximately centered and bolted to the post using the **Upstream** hole of the 4F-T™ Spacer Block and SYTP® post. (pp. 23, 24, 25, 26, 27)
- 11. Ensure the 4F-T™ 10 ga System Rail panels are oriented with the **long slots** and **dimples** assembled **downstream**. (p. 28)
- 12. Ensure the 5/8" heavy flat washers (**1/4" thick**) are placed between the nuts and spacers at Posts 1-9. (pp. 23, 24, 28)
- 13. Ensure all 4F-T™ 10 ga System Rail Guardrails are lapped to the **outside** of the **downstream** rail panels. (p. 28)
- 14. Ensure all 4F-T™ 10 ga System Rail are installed 31" [787 mm] (+1", -0") [+25 mm, -0 mm] from finished grade. (pp. 24, 28)
- 15. Ensure all 4F-T™ fasteners identified in Step 16 are **torqued** to 100 ft-lb [135 Nm], (+/- 5 ft-lb) [+/-7 Nm]. (p. 33)
- 16. Ensure the 4F-T™ Backing Plate is assembled on the **outside** of the 4F-T™ 10 ga System Rail Panels at Posts 2-9. (p. 26)
- 17. Ensure all 4F-T™ fasteners that are **NOT** required to be **torqued** are tightened to a snug position with a minimum of two (2) bolt threads protruding beyond the nut. (pp. 19, 21, 22, 32)
- 18. Ensure the 4F-T™ Bearing Plate bend is located at the top of the plate, facing Post 1 and the cable is taut. (p. 30)
- 19. Ensure the wire rope portion of the 4F-T™ Anchor Cable is **NOT** in contact with the 4F-T™ Anchor Spacer at Post 2. (p. 31)
- 20. Ensure delineation is placed on the 4F-T™ Impact Head per MUTCD and/or state/specifying agency. (p. 25)
- 21. Ensure that the first line post (Post 10), not included, is not leaning back more than 3" [76 mm]. (p. 25)
- 22. Ensure any steel delineator posts are a minimum of 3' [~1 m] **upstream** from the 4F-T™ Impact Head. (p. 32)

4F-T™ Routine Inspection Checklist

Performed by: _____

Date: _____

Location: _____

Valtir recommends the state/specifying agency develop and administer their own end terminal inspection program, based on location of unit, volume of traffic and impact history.



The 4F-T™ System and all of its components shall be inspected for damage after every impact. Repair using only Valtir parts that are specified for use within the 4F-T™ System.

If no end terminal inspection program exists, Valtir recommends visual drive-by inspections at least once every month and walk-up inspections every six (6) months. These inspections shall, **at a minimum**, consist of:

Visual Drive-By Inspections (Recommended Frequency: Monthly)

- Check for damage caused by vehicle impacts.
- Check for damage caused by impacts from snowplow, mowing or roadway operations.
- Check for misalignment.
- Check for missing system components.
- Check for vandalism.
- Check for damage caused by adverse weather conditions (i.e. erosion, weight of snow, UV).
- Check that the Anchor Cable is taut and the Bearing Plate is properly positioned.

Walk-Up Inspections (Recommended Frequency: Every Six (6) Months)

Walk-Up Inspections shall include ALL Visual Drive-By Inspection items (listed above) as well as the items listed below.

- Ensure required traffic control is in place to conduct walk-up inspection.
- Clear and dispose of any debris or trash found on the 4F-T™ site, which may interfere with the performance of the 4F-T™ System.
- Check that fasteners are fully tightened. See Step 16 for torqued nut locations. All other locations are to be tightened to a snug position with a minimum of two (2) bolt threads protruding beyond the nut.
- Check for erosion to the site grading around the system.
- Ensure the height of the system is being maintained at approximately 31" [787 mm] from finished grade.
- Ensure the 4F-T™ 10 GA System Rail Panels are lapped correctly allowing each of the upstream guardrail panels to translate over the downstream guardrail panels.

If any of the above items are identified during the inspection process, **swift action shall be taken to correct and return the 4F-T™ System to proper condition** outlined in the 4F-T™ System assembly manual, latest edition.

Appendix A: Grading Detail

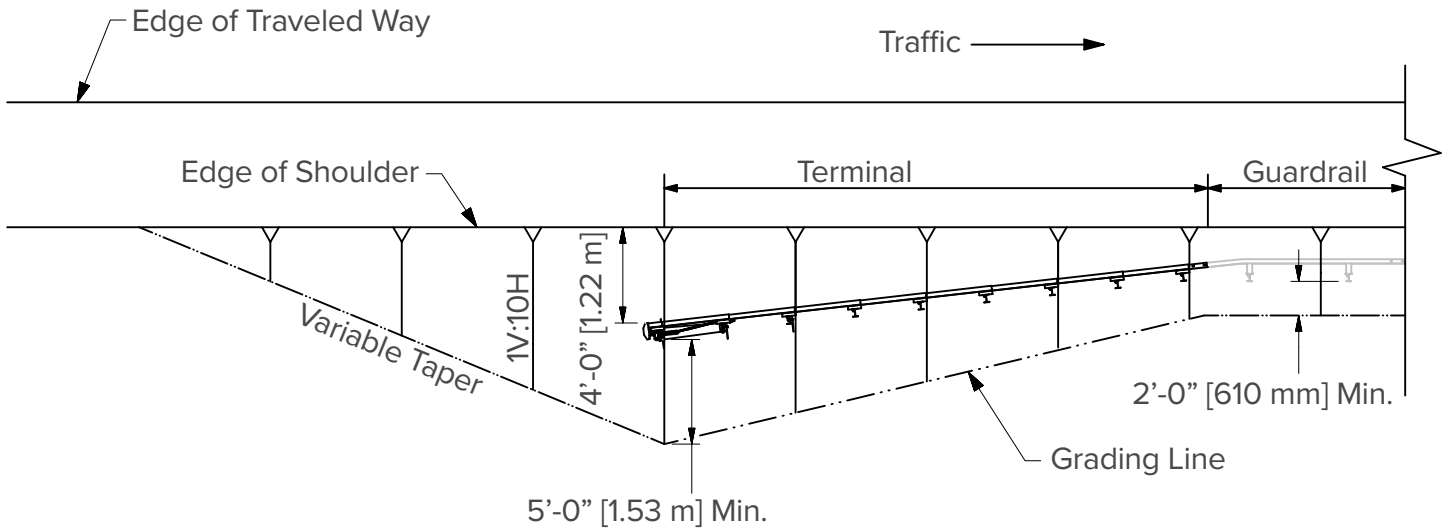

Reference: AASHTO Roadside Design Guide (Current Edition), for flared terminals

Appendix B: Alternative Footings Detail

The following cases provide alternate footing designs when the HBA® Bottom Post 1 cannot be installed due to solid rock, underground utilities, or underground structure.

Case 1: Solid rock is encountered within 0" [0 mm] to 6" [152 mm] below grade.

At post location 1, make a 12" [305 mm] diameter hole into the rock a depth of 36" [914 mm] below finished grade. Cut the HBA® Bottom Post to a length of 30" [762 mm]. Assemble the post in the hole with the top of the post 1 3/4" [44 mm] (+1", -0") [25 mm, -0 mm] above finished grade, see Detail A. Orient the post per Step 4 with the large hole on the downstream side of the post. Fill the hole to within 3" [76 mm] from the surface with 2,800 psi [19.3 MPa] concrete. Do not attach the HBA® Top Post until the concrete reaches 2,800 psi [19.3 MPa].

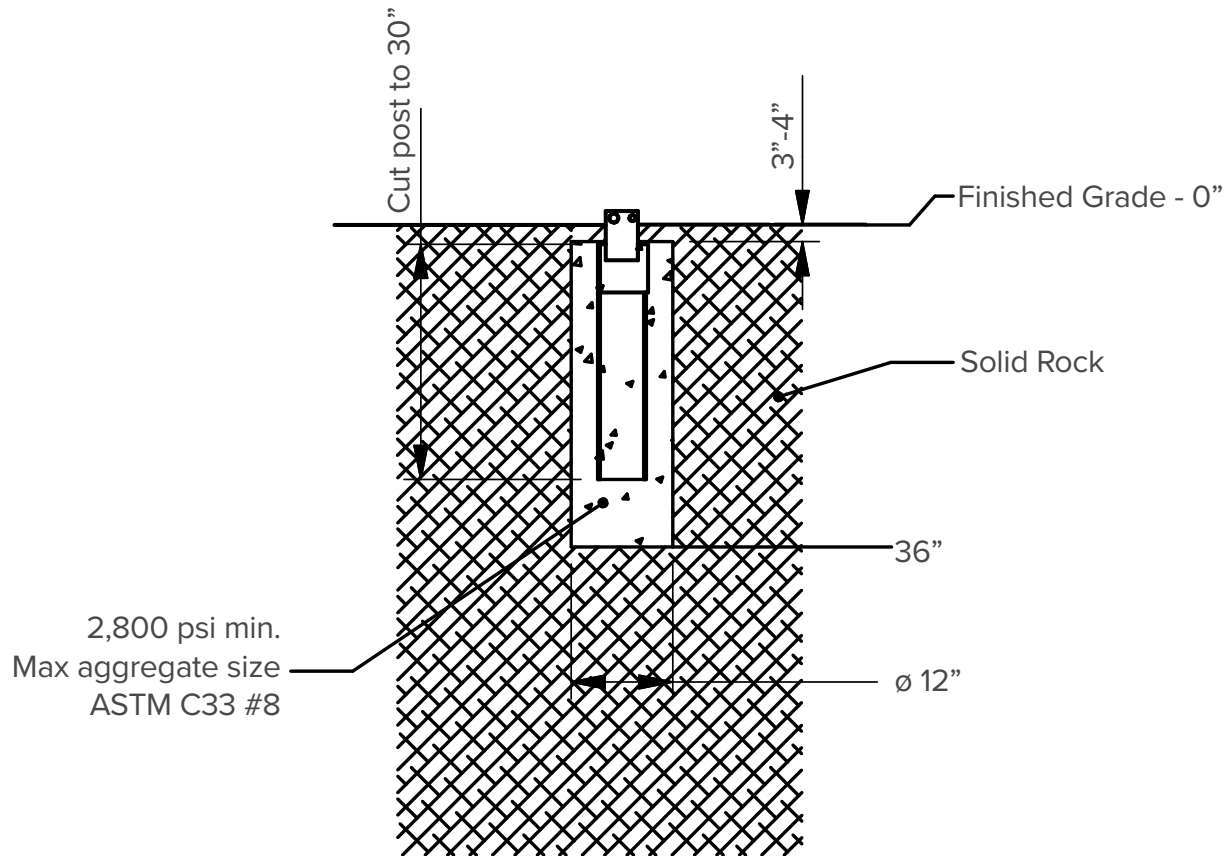

POST 1

DETAIL A

Case 2: Solid rock is encountered between 6" [152 mm] and 36" [914 mm] below finished grade.

At post location 1, make a 30" [762 mm] diameter hole into the rock a depth of 36" [914 mm] below finished grade. Cut the HBA® Bottom Post to a length of 30" [762 mm]. Assemble a rebar cage as shown in Detail B, and insert into the hole 6" [152 mm] below finished grade. Assemble the HBA® Bottom Post in the hole with the top of the post 1 3/4" [44 mm] (+1", -0") [+25 mm, -0 mm] above grade. Orient the post per Step 4 with the large hole on the downstream side of the post. Fill the hole to within 3" [76 mm] from the surface with 2,800 psi [19.3 MPa] concrete. Do not attach the HBA® Top Post until the concrete reaches 2,800 psi [19.3 MPa].

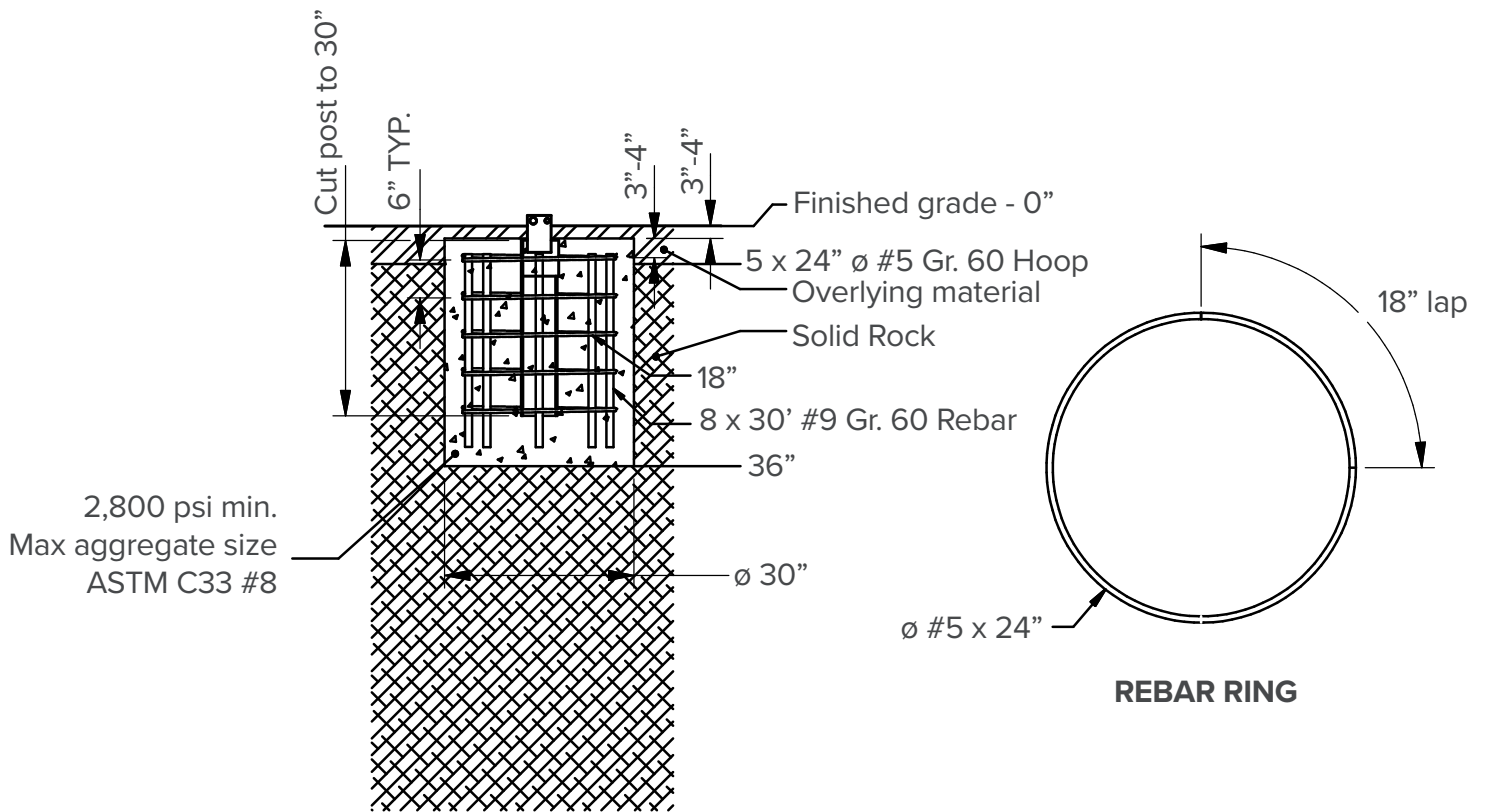

POST 1

DETAIL B

Case 3: Underground obstruction is encountered between 36" [914 mm] and 48" [1.22 m] below the finished grade.

At post location 1, make a 30" [762 mm] diameter hole with a depth of 36" [914 mm] below finished grade. Cut the HBA® Bottom Post to a length of 30" [762 mm]. Assemble a rebar cage as shown in Detail C, and insert into the hole 6" [152 mm] below finished grade. Assemble the HBA® Bottom Post in the hole with the top of the post 1 3/4" [44 mm] (+1", -0") [+25 mm, -0 mm] above finished grade. Orient the post per Step 4 with the large hole on the downstream side of the post. Fill the hole to within 3" [76 mm] from the finished grade with 2,800 psi [19.3 MPa] concrete. Do not attach the HBA® Top Post until the concrete reaches 2,800 psi [19.3 MPa].

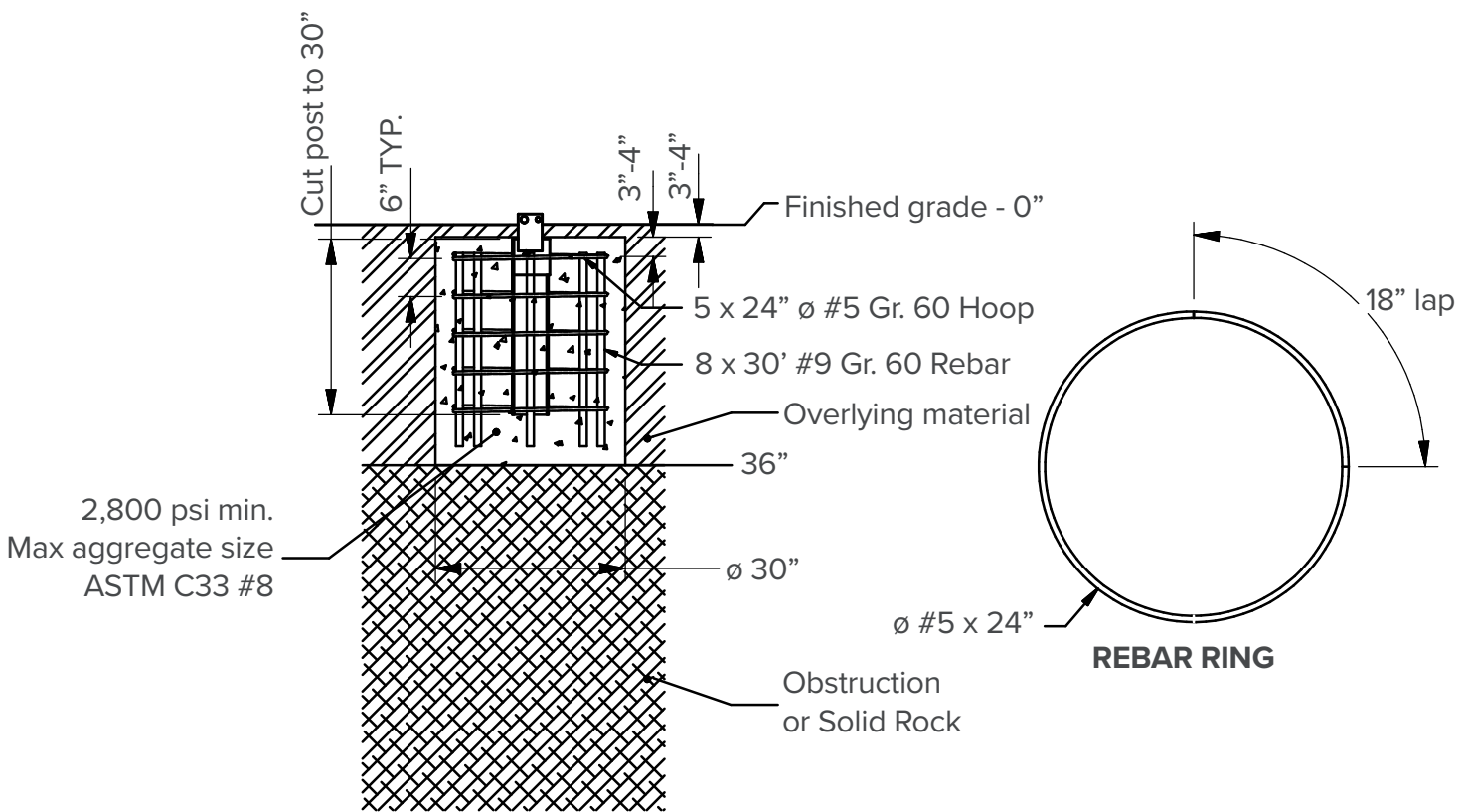

DETAIL C

Case 4: Underground obstruction is encountered between 48" [1.22 m] and 72" [1.83 m] below the finished grade.

At post location 1, make an 18" [457 mm] diameter hole with a depth of 48" [1.22 m] below finished grade. Cut the HBA® Bottom Post to a length of 30" [762 mm]. Assemble a rebar cage as shown in Detail D, and insert into the hole 6" [152 mm] below finished grade. Assemble the HBA® Bottom Post in the hole with the top of the post 1 3/4" [44 mm] (+1", -0") [+25 mm, -0 mm] above finished grade. Orient the post per Step 4 with the large hole on the downstream side of the post. Fill the hole to within 3" [76 mm] from the finished grade with 2,800 psi [19.3 MPa] concrete. Do not attach the HBA® Top Post until the concrete reaches 2,800 psi [19.3 MPa].

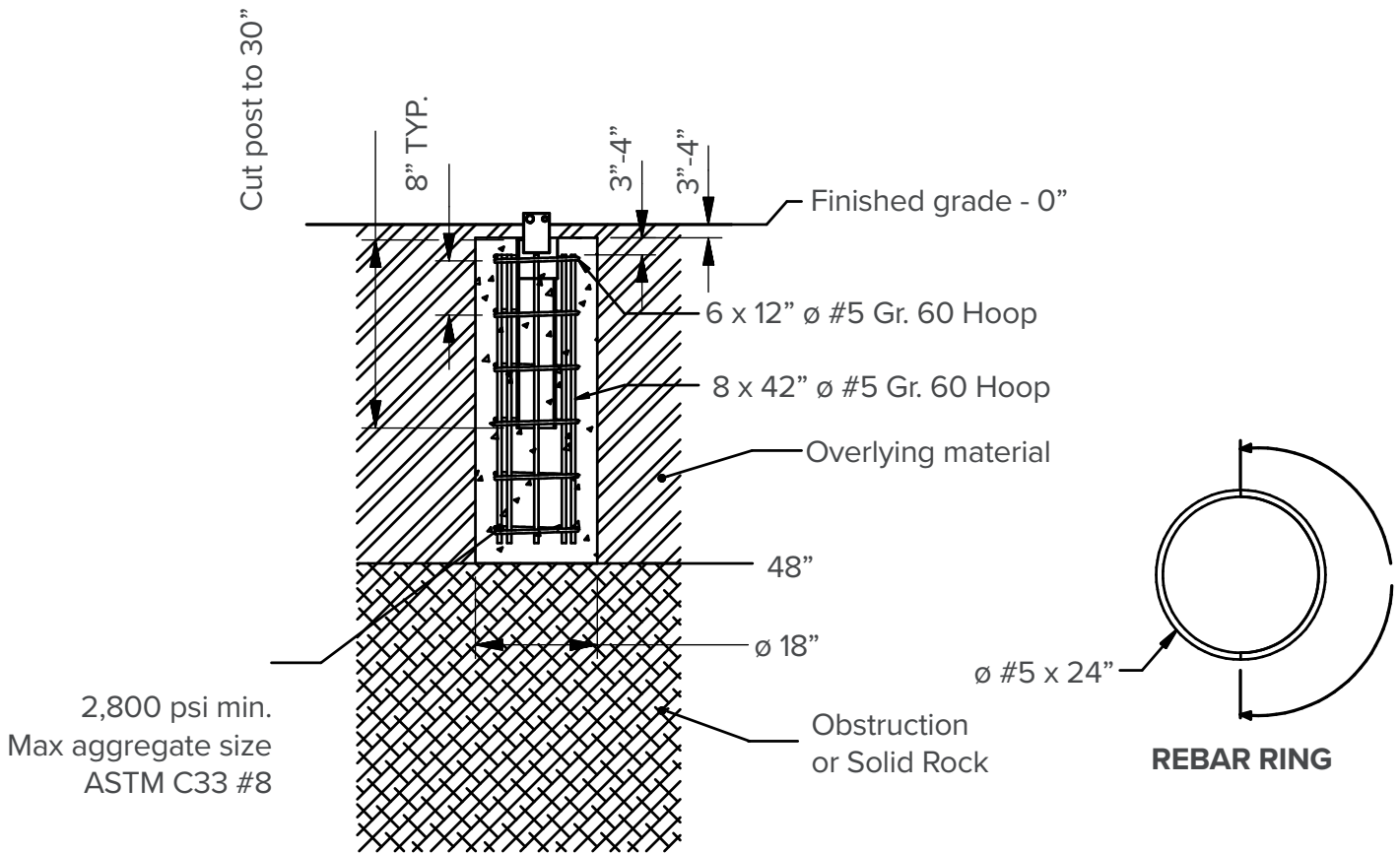

DETAIL D



For more complete information on Valtir products and services, visit us on the web at www.valtir.com. Materials and specifications are subject to change without notice. Please contact Valtir to confirm that you are referring to the most current instructions.

WWW.VALTIR.COM
1.888.356.2363