

**TAU-M™ PARALLEL** | REDIRECTIVE NON-GATING, CRASH CUSHION

- QUICK AND EASY TO INSTALL
- PARTIALLY REUSABLE DESIGN
- MASH TL-3/TL-2 TESTED
- NCHRP 350 TO MASH UPGRADE KITS AVAILABLE



Download on the  
App Store

GET IT ON  
Google Play

The Lindsay Guide  
App is available as a  
free download from  
the Apple Store™ and  
Google Play™.



**LINDSAY**™  
TRANSPORTATION SOLUTIONS

P/N TAU-M (ECN 3883)

**REVISIONS**

<b>DATE</b>	<b>ECN</b>	<b>PUBLISHED ECN</b>	<b>REVISION</b>	<b>DESCRIPTION OF CHANGE</b>
10/01/2018	3883	3883	A	New release

## Important For Your Safety

We have provided important safety messages in this manual. **ALWAYS** read and obey all safety messages.

This is the safety alert symbol.



This symbol alerts you to hazards that can kill or hurt you and others. All safety messages will be preceded by the safety alert symbol and the word “DANGER”, “WARNING”, or “CAUTION”.

These words mean:

 **DANGER** IMMEDIATE HAZARDS THAT WILL RESULT IN SEVERE PERSONAL INJURY OR DEATH.

 **WARNING** Hazards or unsafe practices that **COULD** result in severe personal injury or death.

 **CAUTION** Hazards or unsafe practices that **COULD** result in minor personal injury or product or property damage.

This manual must be available to the person(s) overseeing and/or assembling the crash cushion system at all times. For additional copies, or if you have any questions about any portion of this manual, see below to contact Lindsay Transportation Solutions.

## Contact Information

Lindsay Transportation Solutions

U.S. Toll Free: (888) 800-3691

or

+1 (707) 374-6800

[www.lindsaytransportationsolutions.com](http://www.lindsaytransportationsolutions.com)

## STANDARD LIMITED WARRANTY

Lindsay Transportation Solutions, Inc. (collectively with its parent company Lindsay Corporation and all other subsidiaries and affiliates directly and indirectly owned by Lindsay Corporation, "LTS") has tested the impact performance of certain of its barriers, crash cushion systems, and other highway safety hardware at an ISO-certified crash testing laboratory under controlled conditions pursuant to the test matrix criteria of NCHRP 350, MASH or EN-1317, as applicable, as designated by the American Association of State Highway and Transportation Officials ("AASHTO") and the Federal Highway Administration ("FHWA"), or the European Committee for Standardization ("CEN"). Such tests do not replicate every possible crash scenario and they are not intended to represent the performance of barriers, crash cushion systems, and other highway safety hardware when impacted in every real world impact condition or by every vehicle type. It is widely recognized that there are impact conditions that exceed the performance expectations of all highway safety equipment.

The products with which this limited warranty is provided (the "Products") are intended to be installed, operated, and maintained in a manner not inconsistent with instructional materials provided by LTS, the AASHTO Roadside Design Guide (as applicable), and state and federal guidelines (as applicable). Selection and proper installation, operation, and maintenance of any highway safety product, including the Products, is the responsibility of the highway authority and state department of transportation.

LTS EXPRESSLY DISCLAIMS ANY WARRANTY OR LIABILITY FOR CLAIMS ARISING BY REASONS OF DEATH OR PERSONAL INJURY OR DAMAGE TO PROPERTY RESULTING FROM ANY IMPACT, COLLISION OR HARMFUL CONTACT WITH THE PRODUCTS OR NEARBY HAZARDS OR OBJECTS BY ANY VEHICLE, OBJECTS, OR PERSONS, REGARDLESS OF WHETHER THE PRODUCTS WERE INSTALLED IN CONSULTATION WITH LTS OR BY THIRD PARTIES.

LTS warrants that any Product or component part manufactured by LTS will be free from defects in material or workmanship. LTS will replace free of cost any Product or component part manufactured by LTS that contains such a defect.

THE FOREGOING WARRANTY IS IN LIEU OF AND EXCLUDES ALL OTHER WARRANTIES NOT EXPRESSLY SET FORTH HEREIN, WHETHER EXPRESS OR IMPLIED BY OPERATION OF LAW OR OTHERWISE, INCLUDING BUT NOT LIMITED TO ANY IMPLIED WARRANTIES OF MERCHANTABILITY OR FITNESS FOR A PARTICULAR PURPOSE.

LTS, in its sole discretion, may elect to disclaim the foregoing warranty benefits with respect to (i) any Products that have been inspected and determined by LTS, in its sole discretion, (a) to have been subject to improper storage, accident, misuse, or unauthorized alterations, or (b) that have not been installed, operated, and maintained in accordance with approved procedures and guidelines (including but not limited to instructions included in materials provided by LTS and the AASHTO Roadside Design Guide) and (ii) any components manufactured by the Buyer.

LTS' LIABILITY UNDER THIS WARRANTY IS EXPRESSLY LIMITED TO REPLACEMENT FREE OF COST (IN THE FORM AND UNDER THE TERMS ORIGINALLY SHIPPED), OR TO REPAIR BY LTS, OF PRODUCTS OR PARTS NOT COMPLYING WITH LTS SPECIFICATIONS, OR, AT LTS' ELECTION, TO THE REPAYMENT OF AN AMOUNT EQUAL TO THE PURCHASE PRICE OF SUCH PRODUCTS OR PARTS, WHETHER SUCH CLAIMS ARE FOR BREACH OF WARRANTY OR NEGLIGENCE. LTS SHALL NOT BE LIABLE FOR ANY INCIDENTAL, CONSEQUENTIAL, OR SPECIAL LOSSES, DAMAGES, OR EXPENSES OF ANY KIND, INCLUDING, WITHOUT LIMITATION, ANY SUCH LOSSES, DAMAGES, OR EXPENSES ARISING DIRECTLY OR INDIRECTLY FROM THE SALE, HANDLING, OR USE OF THE PRODUCTS FROM ANY OTHER CAUSE RELATING THERETO, OR FROM PERSONAL INJURY OR LOSS OF PROFIT.

Any claim by the Buyer with reference to Products sold hereunder for any cause shall be deemed waived by the Buyer unless LTS is notified in writing, in the case of defects apparent on visual inspection, within ninety (90) days from the delivery date, or, in the case of defects not apparent on visual inspection, within twelve (12) months from the said delivery date. Products claimed to be defective may be returned prepaid to LTS' plant for inspection in accordance with return shipping instructions that LTS shall furnish to the Buyer forthwith upon receipt of the Buyer's notice of claim. If the claim is established, LTS will reimburse that Buyer for all carriage costs incurred hereunder.

W030587 Rev. 11 revised October 16, 2017



505 Crown Point Avenue • Omaha, NE 68110 • Tel. +1 (402) 829-6800 • Fax. +1 (402) 933-6178

# Table of Contents

Important For Your Safety .....	3
Contact Information .....	3
Standard Limited Warranty .....	4
Universal TAU-M™ Parallel System Overview .....	6
Recommended Tools .....	7
Safety Equipment .....	7
Traffic Control .....	7
Parts Identification .....	8
Bill of Materials.....	13
Preparation .....	17
Documentation .....	18
Important Notes.....	19
Alternative Anchoring Specifications .....	20
System Torque Chart .....	20
Step 1 - Backstop & Front Cable Anchor Installation.....	21
Step 2 - End Panel Mount Installation .....	25
Step 3 - Positioning Mid-Supports.....	26
Step 4 - Cable Installation .....	27
Step 5 - Front Support Assembly .....	28
Step 6 - Panel Installation.....	29
Step 7 - Tether Kit Installation.....	32
Step 8 - Delineation Bracket Installation.....	33
Step 9 - Energy Absorbing Cartridge Installation .....	34
Step 10 - Torque Anchors and Cables .....	35
Step 11 - Tighten Slider Bolts.....	38
Installing a Pre-Built System.....	39
Upgrade a TAU-II System to a TAU-M System .....	40
Inspector Checklist.....	43
Maintenance Inspection.....	44
Drawings.....	47
Long-Term Storage.....	63

## Universal TAU-M™ Parallel System Overview



The Universal TAU-M™ Parallel, (TAU-M™) is a redirective, non-gating crash cushion. The TAU-M system has been tested and evaluated per the recommendations set forth in the *Manual for Assessing Safety Hardware (MASH) Test Level 3 & Test Level 2*. The TAU-M™ system utilizes tensioned cables, telescoping three-beam panels, and energy absorbing cartridges (EAC) to absorb kinetic energy and safely contain or redirect impacting vehicles.

The system is comprised of compression based EACs, two cables, a front cable anchor, a backstop, four end panel mounts, middle support assemblies (mid-supports), cable guides, a Front Support, a Front Support leg kit, Slider Panels, two end panels, Slider Kits, Slider Shims, a tether kit, four tow hooks, and a delineation bracket.

The system has a height of 32-5/8" and a width of 34-1/2". The TAU-M™ varies in system length for each MASH test level by the number of bays. Test Level 3 measures approximately 287" (7 Bays) in length and Test Level 2 measures approximately 185" (4 Bays) in length.

In unidirectional applications, the TAU-M™ is free standing and is not required to be connected to the hazard. Transitions to other barrier systems such as W-Beam guardrail, rigid bridge, or roadside barriers shall be in accordance with Federal, State, and Local requirements.

TAU-M™ is a standalone system and can protect hazards up to 30" in width.

TAU-M™ is also available as a kit for users who have existing TAU-II components or systems and would like to upgrade those NCHRP 350 systems to the MASH compliant system.

## Recommended Tools

**NOTE:** The list of tools, safety equipment, and traffic control is a general recommendation and should not be considered a comprehensive list. Depending on the specific characteristics of the job site and the complexity of the repair or assembly, more or less tools may be necessary.

### Provided Tools

- Cable Socket
- 2-3/4" Cable Swage Key
- 1/2" (12mm) Allen Socket

### Required Tools

- Tape Measure
- Chalk Line
- Marking Paint
- Rotary Hammer
- Masonry Bit
  - 7/8" (22mm) x 10" (254mm)
  - 7/8" (22mm) x 20" (508mm)
- Screwdriver (Flat or Phillips)
- Impact Wrench (pneumatic or electric)
- 3/4" (19mm) Combination Wrench
- 1/2" Drive Ratchet
- 1/2" Drive Extensions
- Compressed Air
- 3/4" Diameter Brush
- 1/2" Drive Torque Wrenches
  - 5 ft-lbf (8 N-m) to 500 ft-lbf (680 N-m)
- 1/2" Drive Deep Sockets
  - 3/4" (19mm)
  - 13/16" (21mm)
  - 15/16" (24mm)
  - 1-1/8" (29mm)

### Optional Tools

If installing a pre-assembled system:

- Extension or Extended 7/8" (22mm) Masonry Bit
  - Length of drill bit will depend on the foundation application.
    - 48" (122cm) long for Concrete foundation
    - 60" (152cm) long for Asphalt foundation

## Safety Equipment

- Safety Glasses
- Hearing Protection
- Gloves
- Steel Toe Boots
- Hard Hat
- Safety Vest
- Dust Mask







## Traffic Control

- Traffic Control Equipment
- Traffic Control Plan

## Parts Identification

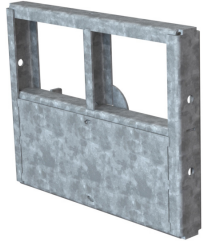



**⚠ WARNING** Use only Lindsay Transportation Solutions parts that are specified by Lindsay Transportation Solutions for use with the TAU-M™ System. Unless specifically included in the NCHRP 350 to MASH Upgrade Kit BOMs do not use or co-mingle parts from other TAU-II and TAU-IIR systems including Non-Lindsay Transportation Solution systems. Such configurations have not been tested nor have they been approved for use. The use of unspecified parts is prohibited and could result in severe personal injury or death.

**NOTE:** Hardware not shown.



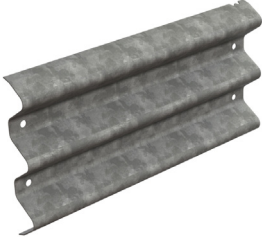
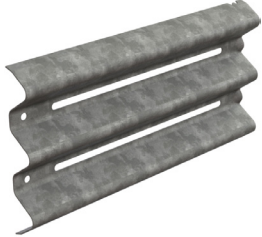
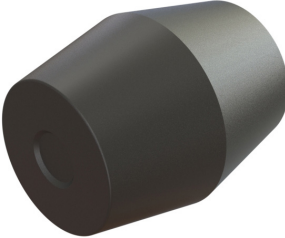

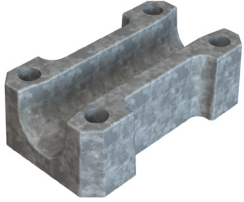
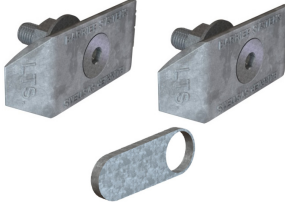
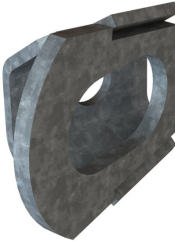
<p>1</p>  <p><b>Compact Backstop, Parallel</b> BSI-1707034-00</p>	<p>2</p>  <p><b>Cable Anchor, Parallel</b> BSI-1708018-00</p>	<p>3</p>  <p><b>Front Support</b> B030704</p>			
TL-2, Qty. 1	TL-3, Qty. 1	TL-2, Qty. 1	TL-3, Qty. 1	TL-2, Qty. 1	TL-3, Qty. 1
<p>4</p>  <p><b>Middle Support Assembly</b> B030703</p>	<p>5</p>  <p><b>Cable Assembly, 7 Bay</b> BSI-1706001-00</p>	<p>6</p>  <p><b>Cable Assembly, 4 Bay</b> BSI-1805036-00</p>			
TL-2, Qty. 3	TL-3, Qty. 6	TL-2, Qty. n/a	TL-3, Qty. 2	TL-2, Qty. 2	TL-3, Qty. n/a

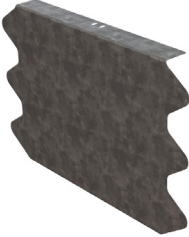

## Parts Identification (Cont.)

<p>7</p>  <p><b>End Panel Mount</b> BSI-1708032-00</p>	<p>8</p>  <p><b>End Panel, Thrie Beam</b> BSI-1708030-00</p>	<p>9</p>  <p><b>Sliding Panel, Galvanized</b> BSI-1708019-00</p>			
TL-2, Qty. 2	TL-3, Qty. 2	TL-2, Qty. 2	TL-3, Qty. 2	TL-2, Qty. 8	TL-3, Qty. 14
<p>10</p>  <p><b>Cartridge, Energy Absorbing</b> B010722</p>	<p>12</p>  <p><b>Front Support Leg</b> BSI-1209011-00</p>	<p>16</p>  <p><b>Cable Guide</b> BSI-1707032-00</p>			
TL-2, Qty. 4	TL-3, Qty. 7	TL-2, Qty. 2	TL-3, Qty. 2	TL-2, Qty. 6	TL-3, Qty. 12
<p>20</p>  <p><b>Slider Kit</b> BSI-1809041-KT</p>	<p>27</p>  <p><b>Tow Hook Kit</b> BSI-1711051-00</p>	<p>32</p>  <p><b>Tether Kit</b> BSI-1709083-KT</p>			
TL-2, Qty. 4	TL-3, Qty. 7	TL-2, Qty. 1	TL-3, Qty. 1	TL-2, Qty. 1	TL-3, Qty. 1

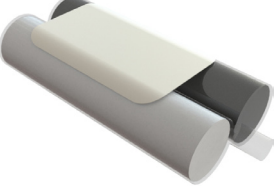
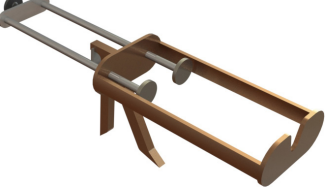

## Parts Identification (Cont.)

<p>40</p>  <p><b>Bracket, Delineation</b> BSI-1708027-00</p>	<p>46</p>  <p><b>Anchor - 3/4" x 8-1/4"</b> B011001</p>	<p>49</p>  <p><b>Epoxy</b> 4004301</p>			
TL-2, Qty. 1	TL-3, Qty. 1	TL-2, Qty. 25	TL-3, Qty. 25	TL-2, Qty. 2	TL-3, Qty. 2
<p>50</p>  <p><b>Epoxy Dispenser</b> 4002468</p>	<p>51</p>  <p><b>Epoxy Nozzle</b> 4004302</p>				
TL-2, Qty. 1	TL-3, Qty. 1	TL-2, Qty. 2	TL-3, Qty. 2		

## Parts Identification (Cont.) (Asphalt System)

<p>52</p>  <p><b>Crossmember, Galvanized</b> BSI-1806012-00</p>	<p>53</p>  <p><b>Backstop Brace, Right</b> BSI-1806016-00</p>	<p>54</p>  <p><b>Backstop Brace, Left</b> BSI-1806018-00</p>			
TL-2, Qty. 1	TL-3, Qty. 1	TL-2, Qty. 1	TL-3, Qty. 1	TL-2, Qty. 1	TL-3, Qty. 1
<p>55</p>  <p><b>Rear Plate, Galvanized</b> BSI-1806006-00</p>	<p>56</p>  <p><b>Tie Channel, Galvanized</b> BSI-1806008-00</p>	<p>57</p>  <p><b>Sliding Panel, Galvanized</b> BSI-1708019-00</p>			
TL-2, Qty. 1	TL-3, Qty. 1	TL-2, Qty. 1	TL-3, Qty. 1	TL-2, Qty. -	TL-3, Qty. 4
<p>58</p>  <p><b>Slider Shim</b> BSI-1803016-00</p>	<p>60</p>  <p><b>Anchor - 3/4" x 18"</b> B020353</p>	<p>63</p>  <p><b>Epoxy</b> 4004301</p>			
TL-2, Qty. -	TL-3, Qty. 8	TL-2, Qty. 53	TL-3, Qty. 53	TL-2, Qty. 8	TL-3, Qty. 8

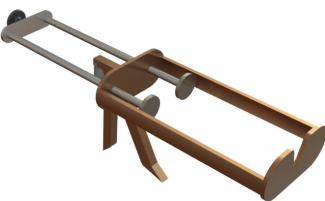
## Parts Identification (Cont.) (Asphalt System)

64		65	
			
<b>Epoxy Dispenser</b> 4002468		<b>Epoxy Nozzle</b> 4004302	
TL-2, Qty. 1	TL-3, Qty. 1	TL-2, Qty. 4	TL-3, Qty. 8

# Bill of Materials

## Overall System

Item #	Part #	Description	TL-2	TL-3
1	BSI-1707034-00	Compact Backstop, Galvanized, Parallel	1	1
2	BSI-1708018-00	Galvanized Cable Anchor, TAU-M, Parallel	1	1
3	B030704	Front Support	1	1
4	B030703	Middle Support Assembly	3	6
5	BSI-1706001-00	Cable Assembly, 7 Bay, TAU-M	-	2
6	BSI-1805036-00	Cable Assembly, 4 Bay, TAU-M	2	-
7	BSI-1708032-00	End Panel Mount	4	4
8	BSI-1708030-00	End Panel, Thrie Beam, Galvanized, TAU-M	2	2
9	BSI-1708019-00	Sliding Panel, Galvanized, TAU-M	8	14
10	B010722	Cartridge, TAU-II, Type B, Energy Absorbing	4	7
11	K001005	TAU-II Front Support Leg Kit	1	1
12	BSI-1209011-00	Front Support Leg	2	2
13	2001793	C-Scr HH 5/8-11 x 2 Gr5 GEOMET	2	2
14	2001794	WASHER SAE 5/8" GEOMET	2	2
15	BSI-1808033-KT	Cable Guide Kit, TAU-M	3	6
16	BSI-1707032-00	CABLE GUIDE, GALVANIZED	6	12
17	BSI-2001957	C-Scr HH 1/2-13 x 3-1/4", Gr5 GEOMET	24	48
18	2001791	WASHER SL, 1/2" STANDARD, FINISH: GEOMET	24	48
19	2001797	NUT HN, 1/2-13, Gr5, FINISH GEOMET	24	48
20	BSI-1809041-KT	Slider TAU-M Kit	4	7
21	K001003	TAU-II Slider Kit	4	7
22	BSI-1208032-00	SLIDER FLAT, GALV	16	28
23	2001788	C-Scr FSH 3/4-10 x 3" Gr5 GEOMET	16	28
24	2001789	NUT HN 3/4-10 Gr5 GEOMET	16	28
25	2001790	WASHER FLAT 3/4" STD GEOMET	16	28
26	BSI-1803016-00	Slider Shim, Geomet, TAU-M	16	28
27	BSI-1809040-KT	Tow Hook Kit, TAU-M	1	1
28	BSI-1711051-00	Tow Hook, Galvanized, TAU-M	4	4

## Bill of Materials (Cont.)

Item #	Part #	Description	TL-2	TL-3
29	2001795	C-Scr HH 3/4-10 x 2, Geomet	4	4
30	2001789	Nut HN, 3/4-10, Gr5, Geomet	4	4
31	2001790	Washer, 3/4" STD, Geomet	4	4
32	BSI-1709083-KT	Tether Kit, TAU-M	1	1
33	4000316	3/16" Galvanized Wire Tether	1	1
34	4000317	3/16" Galvanized Wire Rope Clamp	2	2
35	BSI-1808035-KT	End Panel HW Kit, TAU-M	1	1
36	BSI-2001956	C-Scr HH 3/4-10 X 3-1/2", Gr5 Geomet	4	4
37	2001789	Nut HN, 3/4-10, Gr5, Geomet	4	4
38	2001790	Washer, 3/4" STD, Geomet	4	4
39	BSI-1808034-KT	DELINEATION HW KIT, TAU-M	1	1
40	BSI-1708027-00	Bracket, Delineation, TAU-M	1	1
41	2001809	Nut HN 3/8-16, Gr5, Geomet	2	2
42	2001810	Washer 3/8" Std, Geomet	4	4
43	2001811	Washer SL 3/8" Std, Geomet	2	2
44	2001816	C-Scr HH 3/8-16 x 1-1/2", Gr5, Geomet	2	2
45	BSI-1808036-KT	Concrete Anchor Hardware Kit, TAU-M	1	1
46	B011001	Threaded Anchor 3/4-10 x 8-1/4" Gr2	25	25
47	2001399	Nut HN 3/4-10 HVY A563 HD Galv	25	25
48	2001380	WSHR 3/4" F436 Flat Rd Struct	25	25
49	4004301	Epoxy Ultbd 1, A22+1 Nozl	2	2
50	4002468	Epoxy Dispenser	1	1
51	4004032	Epoxy Nozzle	2	2

## Bill of Materials (Cont.)

### Asphalt Kit BOM

Item #	Part #	Description	TL-2	TL-3
52	BSI-1806012-00	Crossmember, Galvanized	1	1
53	BSI-1806016-00	Backstop Brace, Right Hand, Galvanized	1	1
54	BSI-1806018-00	Backstop Brace, Left Hand, Galvanized	1	1
55	BSI-1806006-00	Rear Plate, Galvanized	1	1
56	BSI-1806008-00	Tie Channel, Galvanized	1	1
57	BSI-1708019-00	Sliding Panel, Galvanized, TAU-M	-	4
58	BSI-1803016-00	Slider Shim, Geomet, TAU-M	-	8
59	BSI-1806038-KT	Asphalt Hardware Kit	1	1
60	B020353	Threaded Anchor 3/4-10 x 18" Gr2	53	53
61	2001399	Nut HN 3/4-10 HVY A563 HD Galv	53	53
62	2001380	WSHR 3/4" F436 Flat Rd Struct	53	53
63	4004301	Epoxy Ultbd 1, A22+1 Nozl	8	8
64	4002468	Epoxy Dispenser	1	1
65	4004032	Epoxy Nozzle	4	4

### 350 to MASH Upgrade Kit BOM – CONCRETE

Item #	Part #	Description	TL-2	TL-3
2	BSI-1708018-00	Galvanized Cable Anchor, TAU-M, Parallel	1	1
5	BSI-1706001-00	Cable Assembly, 7 Bay, TAU-M	-	2
6	BSI-1805036-00	Cable Assembly, 4 Bay, TAU-M	2	-
8	BSI-1708030-00	End Panel, Thrie Beam, Galvanized, TAU-M	2	2
9	BSI-1708019-00	Sliding Panel, Galvanized, TAU-M	8	14
15	BSI-1808033-KT	Cable Guide Kit, TAU-M	3	6
26	BSI-1803016-00	Slider Shim, Geomet, TAU-M	16	28
29	BSI-1809040-KT	TOW HOOK KIT, TAU-M	1	1
32	BSI-1709083-KT	Tether Kit, TAU-M	1	1
35	BSI-1808035-KT	END PANEL HW KIT	1	1
39	BSI-1808034-KT	DELINEATION HW KIT, TAU-M	1	1
45	BSI-1808036-KT	Concrete Anchor Hardware Kit, TAU-M	1	1

## Bill of Materials (Cont.)

### 350 to MASH Upgrade Kit BOM – ASPHALT

Item #	Part #	Description	TL-2	TL-3
1	BSI-1707034-00	Compact Backstop, Galvanized, Parallel	1	1
2	BSI-1708018-00	Galvanized Cable Anchor, TAU-M, Parallel	1	1
5	BSI-1706001-00	Cable Assembly, 7 Bay, TAU-M	-	2
6	BSI-1805036-00	Cable Assembly, 4 Bay, TAU-M	2	-
8	BSI-1708030-00	End Panel, Thrie Beam, Galvanized, TAU-M	2	2
9	BSI-1708019-00	Sliding Panel, Galvanized, TAU-M	8	14
15	BSI-1808033-KT	Cable Guide Kit, TAU-M	3	6
26	BSI-1803016-00	Slider Shim, Geomet, TAU-M	16	36
27	BSI-1809040-KT	TOW HOOK KIT, TAU-M	1	1
32	BSI-1709083-KT	Tether Kit, TAU-M	1	1
35	BSI-1808035-KT	END PANEL HW KIT	1	1
39	BSI-1808034-KT	DELINEATION HW KIT, TAU-M	1	1
Include Asphalt Kit				
52	BSI-1806012-00	Crossmember, Galvanized	1	1
53	BSI-1806016-00	Backstop Brace, Right Hand, Galvanized	1	1
54	BSI-1806018-00	Backstop Brace, Left Hand, Galvanized	1	1
55	BSI-1806006-00	Rear Plate, Galvanized	1	1
56	BSI-1806008-00	Tie Channel, Galvanized	1	1
57	BSI-1708019-00	Sliding Panel, Galvanized, TAU-M	-	4
58	BSI-1803016-00	Slider Shim, Geomet, TAU-M	-	8
59	BSI-1806038-KT	Asphalt Hardware Kit	1	1
60	B020353	Threaded Anchor 3/4-10 x 18" Gr2	53	53
61	2001399	Nut HN 3/4-10 HVY A563 HD Galv	53	53
62	2001380	WSHR 3/4" F436 Flat Rd Struct	53	53
63	4004301	Epoxy Ultbd 1, A22+1 Nozl	8	8
64	4002468	Epoxy Dispenser	1	1
65	4004032	Epoxy Nozzle	4	4



## Preparation

### Foundation

Identify site foundation requirements and refer to page 47 for LTS Foundation Specifications. There are two (2) approved foundation configurations for the TAU-M™ system.

1. Solid concrete pad over the length of the system.
2. Asphaltic Concrete foundation, requiring additional anchorage hardware.

Variations of these foundations may be reviewed and determinations made as equivalent by the Project Engineer.

### Transition

Identify site transition requirements and refer to pages 54 through 62 for LTS Transition Options. There are nine (9) approved transition configurations for the TAU-M™ system.

1. Median Barrier, Bi-Directional (Page 54)
2. Safety Shape PCB, Bi-Directional (Page 55)
3. Safety Shape PCB, One Side, Bi-Directional (Page 56)
4. Safety Shape PCB, Offset, Bi-Directional (Page 57)
5. Concrete End Shoe, Bi-Directional (Page 58)
6. Thrie Beam Rail, Bi-Directional (Page 59)
7. W-Beam Rail, Bi-Directional (Page 60)
8. Offset PCB with End Shoe, Bi-Directional (Page 61)
9. Compact Backstop, Unidirectional Traffic Flow (Page 62)

Placement and installation of the TAU-M™ system and transitions must be accomplished in accordance with the guidelines and recommendations set forth in the “AASHTO Road Side Design Guide” FHWA memorandum and other state and local standards.

Before installing the TAU-M™ system, ensure that all the materials required for the system are on site and have been identified.

---

## Documentation

Prior to installation and assembly of the TAU-M™ system, ensure you have read and understand the installation and assembly instructions. The following items should be reviewed and understood prior to installation.

- Installation and Assembly Manual (check for current revision posted at <http://www.barriersystemsinc.com/> See page 2.
- Installation and Assembly Video, Mobile App - The Lindsay Guide App is available as a free download from the Apple Store® and Google Play™.
- Installation and Assembly Video, Online - Full installation videos can be viewed online at <http://lindsay.guide>
- System Drawings (check <http://www.barriersystemsinc.com/> for current revision, located in installation manual.)

## Important Notes

- TAU-M™ system is also provided as a kit-able system for users who have existing TAU-II components or systems and would like to upgrade those NCHRP 350 systems to the MASH compliant system. See page 40 for installation instructions.
- Ensure the TAU-M™ system is properly transitioned in accordance with Federal, State, and Local standards.
- The TAU-M™ system requires a transition in bi-directional traffic. See pages 54 through 61 for acceptable transition configurations.
  - TAU-M™ is a free standing system in unidirectional traffic and does not require a transition. See page 62.
- Sign Convention
  - The term Upstream = Towards the Front Support
  - The term Downstream = Towards Backstop
- This manual follows installation steps for a complete TAU-M™ system that is installed on site.
- For pre-built systems see page 39 for installation instructions.
- Asphalt instructions will be enclosed in a green box:

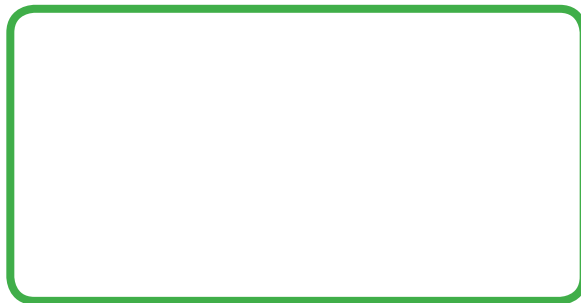

## Alternative Anchoring Specifications

The TAU-M™ system uses threaded rod and epoxy to anchor the Compact Backstop and Front Cable Anchor as well as transition options.

Alternative anchorage hardware/methods (epoxy systems or mechanical anchors) may be used such that they meet or exceed the mechanical properties as follows:

	Foundation Anchors (Concrete Application Only)
Hardware Diameter	3/4"
Ultimate Pull-out Strength*	39,000 lbs
Ultimate Shear Strength*	32,000 lbs

\*Values calculated with embedment depth at 6 3/4".

## System Torque Chart

Concrete Installation	
Anchor Bolts	120 ft-lbs (160 N-m)
Cables	500 ft-lbs (675 N-m)*
Asphalt Installation	
Anchor Bolts	5 ft-lbs (8 N-m)
Cables	120 ft-lbs (160 N-m)
System Component Installation	
Cable Guides	30 ft-lbs (48 N-m)
End Panel Mounts	70 ft-lbs (95 N-m)
Front Support	120 ft-lbs (160 N-m)

\* Using a torque wrench is always the preferred method to tighten hardware for the TAU-M™ system.

If a torque wrench with the capacity to torque 500 ft-lbs is not available, alternative methods may be followed to approximate this torque specification.

- 72" (1.8m) wrench extension with 100 lbs (45 kg) applied 12" (30.5 cm) from the end.
- 42" (1.1m) wrench extension with 200 lbs (90 kg) applied 12" (30.5 cm) from the end.

## Step 1 - Backstop & Front Cable Anchor Installation (Concrete)

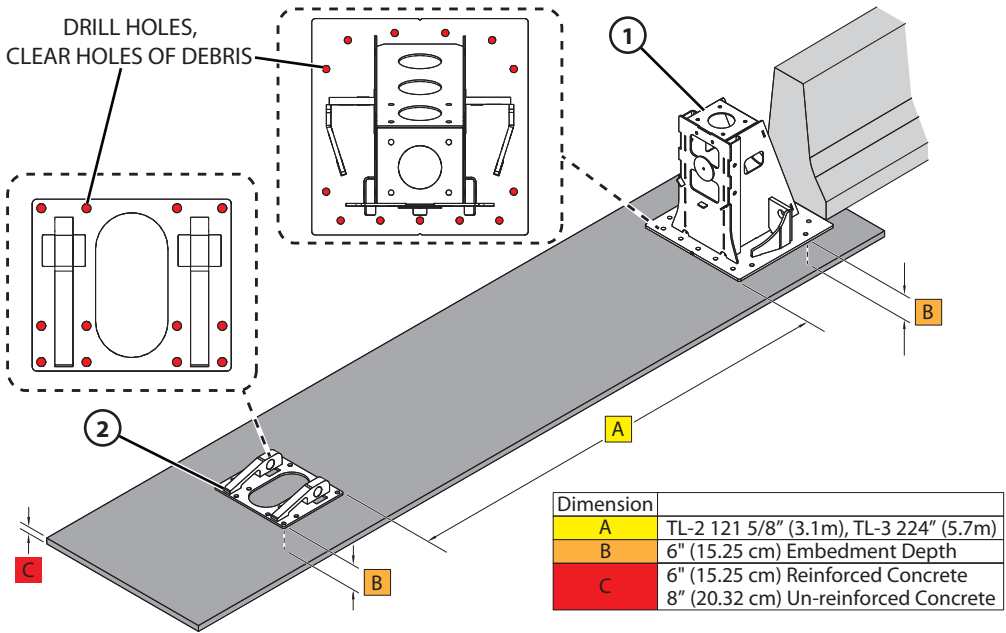

Item #	Part #	Description	QTY
1	BSI-1707034-00	Compact Backstop, Galvanized, Parallel	1
2	BSI-1708018-00	Galvanized Cable Anchor, TAU-M, Parallel	1

**NOTE:** Depending on the type of hazard and/or transition requirements the Compact Backstop (item 1) may need to be spaced away from the hazard for access to the cable lug later in the installation process. Refer to pages 54 through 62 for transition requirements.

- 1.1 Position Compact Backstop (item 1) and space the Front Cable Anchor (item 2) as shown. Refer to the table below for displacement value. Measurement is taken from the front of the Compact Backstop base plate to the rear of the Front Cable Anchor base plate. See page 22 for additional installation in asphalt.
- 1.2 Once the Compact Backstop and Front Cable Anchor are positioned, mark and drill into the foundation at all hole locations. Drill 7/8" hole diameter for supplied epoxy. If other epoxy is used, follow manufacturer's recommendations for 3/4" threaded rod. See page 20 for anchor specifications.
- 1.3 Clear holes of debris with compressed air and brush. Wear PPE.

**⚠ DANGER** HOLES MUST BE DRILLED TO DEPTH AND CLEARED OF DEBRIS TO ENSURE PROPER ANCHORAGE IS ACHIEVED.

**⚠ CAUTION** Wear proper PPE when drilling and clearing debris. This operation produces silica dust.

## Step 1 (Cont.) - Backstop & Front Cable Anchor Installation (Asphalt)

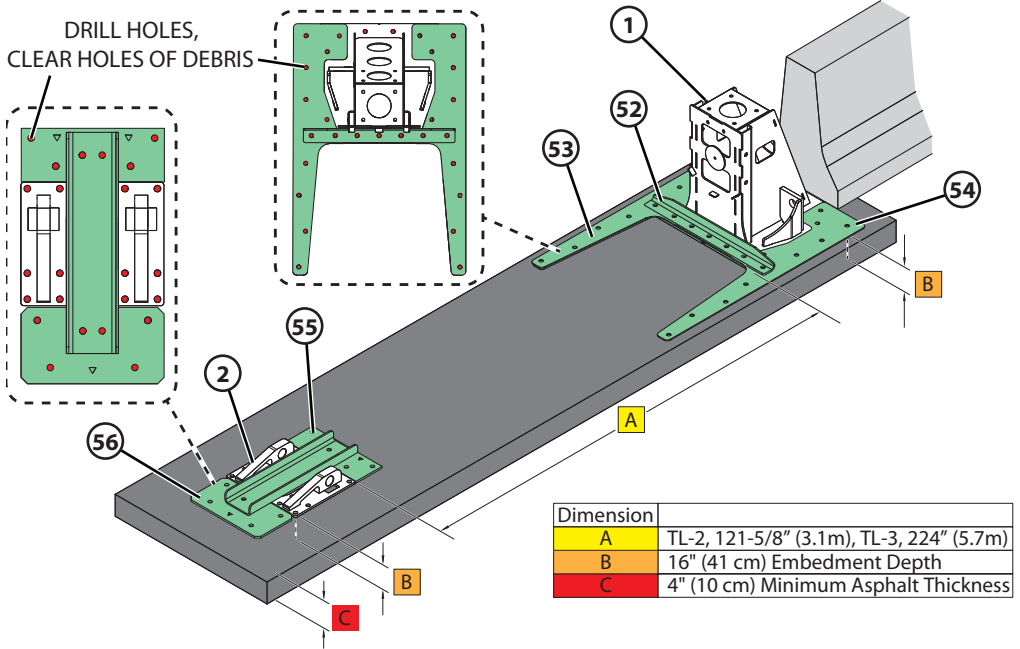

**NOTE:** If the foundation is asphalt, in addition to Step 1.1, the following components will need to be installed accordingly. The Concrete Anchor Hardware kit (item 45) shall be replaced with the Asphalt Anchor Hardware kit (item 59).

Item #	Part #	Description	QTY
52	BSI-1806012-00	Crossmember, Galvanized	1
53	BSI-1806016-00	Backstop Brace, Right Hand, Galvanized	1
54	BSI-1806018-00	Backstop Brace, Left Hand, Galvanized	1
55	BSI-1806006-00	Rear Plate, Galvanized	1
56	BSI-1806008-00	Tie Channel, Galvanized	1

## Step 1 (Cont.)- Backstop & Front Cable Anchor Installation (Concrete)

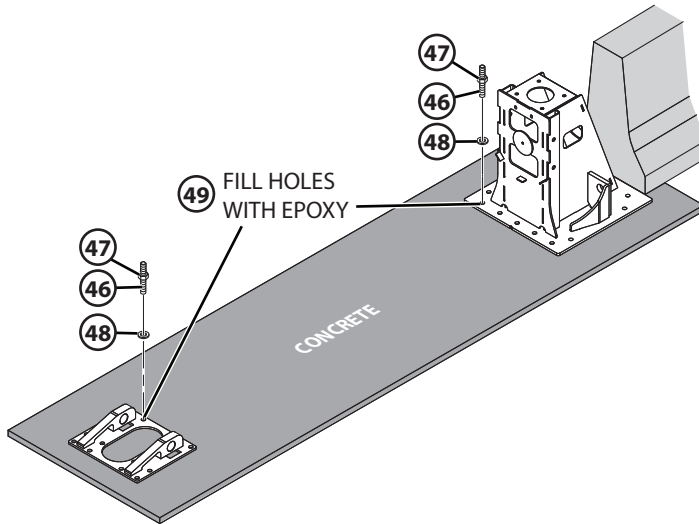

Item #	Part #	Description	QTY
45	BSI-1808036-KT	Concrete Anchor Hardware Kit, TAU-M	1
46	B011001	Threaded Anchor 3/4-10 x 8-1/4" Gr2	25
47	2001399	Nut HN 3/4-10 HVY A563 HD Galv.	25
48	2001380	WSHR 3/4" F436 Flat Rd Struct.	25
49	4004301	Epoxy Ultbd 1, A22+1 Nozl.	2
50	4002468	Epoxy Dispenser	1
51	4004302	Epoxy Nozzle	2

**PRO-TIP:** Preassemble threaded anchor, nut and washer with 3-4 threads minimum on top of the nut.

1.4 Using the supplied hardware kit, fill cleared holes with epoxy and insert threaded rods with washer and nut into each drilled hole. Allow to cure per manufacturer's instruction. Cure time will vary based on ambient temperature.

**NOTE:** Torque anchor bolts AFTER epoxy has been cured per manufacturer's requirements found on epoxy cartridge. For full system torque specifications, see page 20.

## Step 1 (Cont.) - Backstop & Front Cable Anchor Installation (Asphalt)

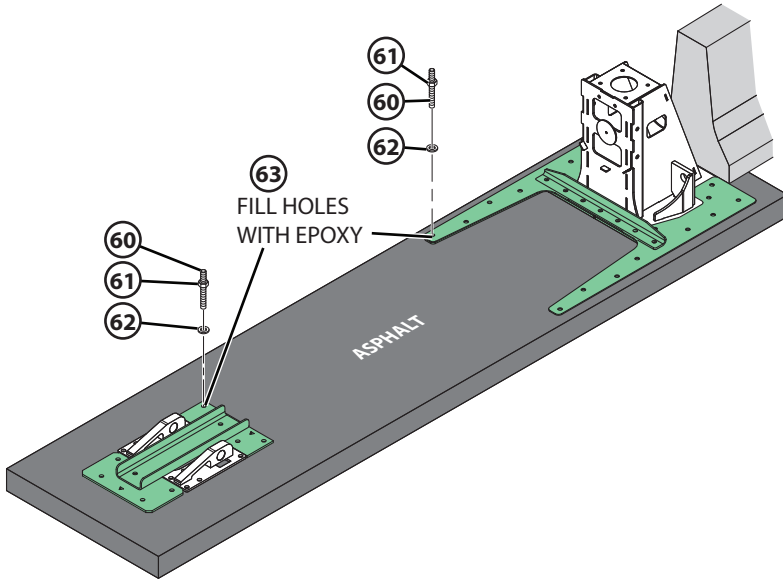

Item #	Part #	Description	QTY
59	BSI-1806038-KT	Asphalt Hardware Kit	1
60	B020353	Threaded Anchor 3/4-10 x 18" Gr2	53
61	2001399	Nut HN 3/4-10 HVY A563 HD Galv	53
62	2001380	WSHR 3/4" F436 Flat Rd Struct	53
63	4004301	Epoxy Ultbd 1, A22+1 Nozl	8
64	4002468	Epoxy Dispenser	1
65	4004302	Epoxy Nozzle	8



## Step 2 - End Panel Mount Installation

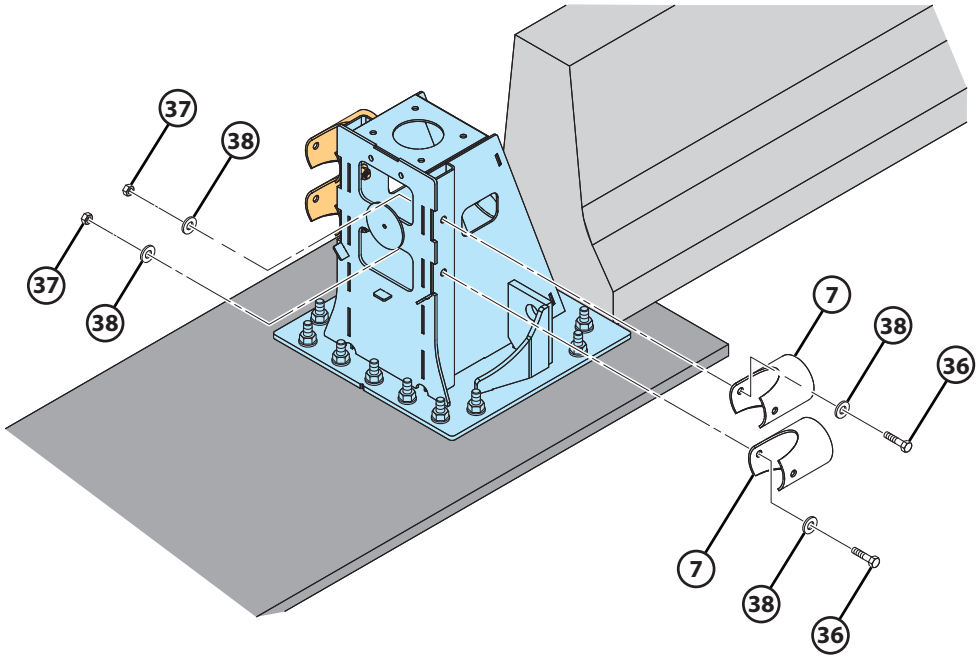

Item #	Part #	Description	QTY
7	BSI-1708032-00	End Panel Mount	4*
35	BSI-1808035-KT	End Panel HW Kit	1
36	BSI-2001956	C-Scr HH 3/4-10 X 3-1/2",Gr5 Geomet	4
37	2001789	Nut HN, 3/4-10, Gr5, Geomet	4
38	2001790	Washer, 3/4" STD, Geomet	4

\*May Use NCHRP 350 TAU-II Component

2.1 Install End Panel Mounts (item 7) using the hardware kit (item 35) to the Compact Backstop as shown. **Torque to 70 ft-lbs (95 N-m).**

**NOTE:** Ensure End Panel Mounts are horizontal as shown. Cutout faces upstream.

## Step 3 - Positioning Mid-Supports

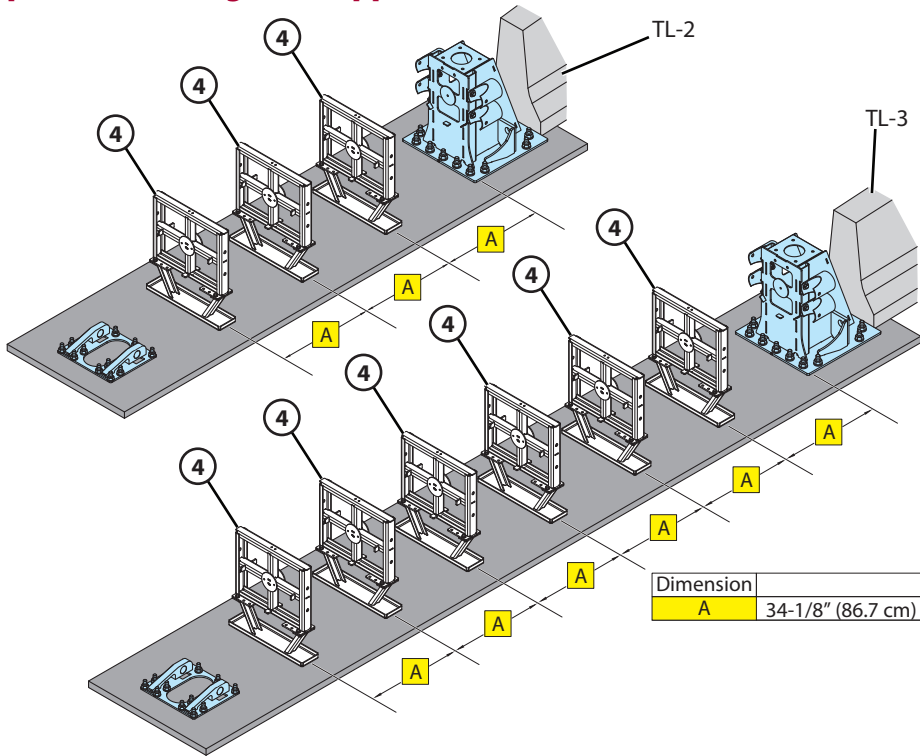

Item #	Part #	Description	QTY	
			TL-2	TL-3
4	B030703	Middle Support Assembly	3	6

3.1 Space Mid-Supports (item 4) approximately 34-1/8" (86.7 cm) (center-to-center) apart from each other as well as from the End Panel Mount bolt holes.

**NOTE:** Final position of Mid-Supports will be set when Slider Panels are installed.

## Step 4 - Cable Installation

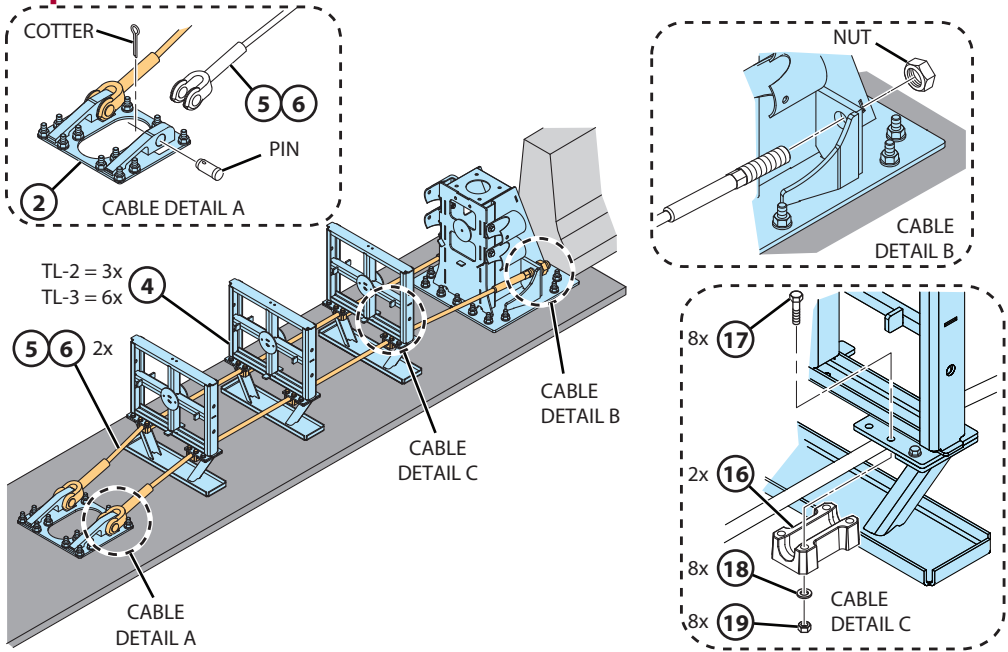

Item #	Part #	Description	QTY	
			TL-2	TL-3
5	BSI-1706001-00	Cable Assembly, 7 Bay, TAU-M	-	2
6	BSI-1805036-00	Cable Assembly, 4 Bay, TAU-M	2	-
15	BSI-1808033-KT	Cable Guide Kit, TAU-M	3	6
16	BSI-1707032-00	CABLE GUIDE, GALVANIZED	6	12
17	BSI-2001957	C-Scr HH 1/2-13 x 3-1/4", Gr5 GEOMET	48	64
18	2001791	WASHER SL, 1/2" STANDARD, GEOMET	48	64
19	2001797	NUT HN, 1/2-13, Gr5, FINISH GEOMET	48	64

- 4.1 Identify test level requirement, use appropriate Cable Assemblies (item 5 or 6).
- 4.2 Pass Cable Assemblies (item 5 or 6) through the legs of the Mid-Support (item 4).
- 4.3 Pass threaded end of Cable Assemblies through the Compact Backstop cable lug. Secure with nut provided with the Cable Assemblies. **DO NOT TIGHTEN.**
- 4.4 Secure clevis end of Cable Assemblies to Front Cable Anchor (item 2) as shown in Detail A.
- 4.5 Secure Cable Assemblies to Mid-Support using Cable Guide Kit (item 15) as shown in Detail C. **Torque to 30 ft-lbs (48 N-m).**

## Step 5 - Front Support Assembly

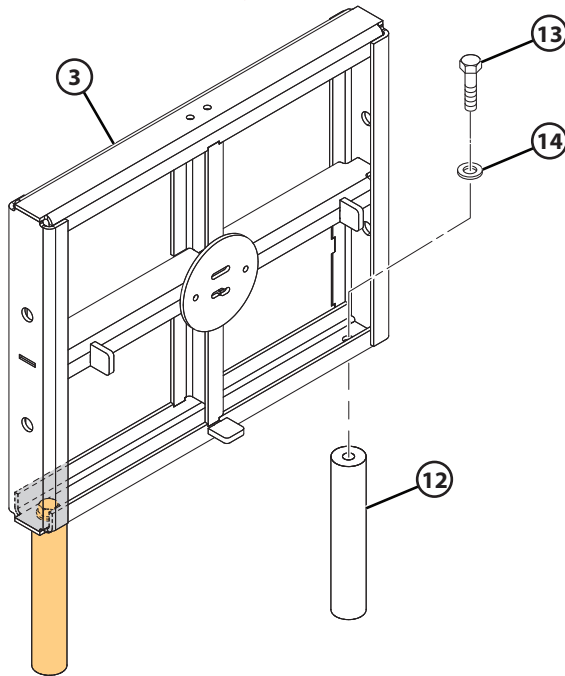

Item #	Part #	Description	QTY
3	B030704	Front Support	1
11	K001005	TAU-II Front Support Leg Kit	1
12	BSI-1209011-00	Front Support Leg	2
13	2001793	C-Scr HH 5/8-11 x 2 Gr5 GEOMET	2
14	2001794	WASHER SAE 5/8" GEOMET	2

- 5.1 Install Front Support Leg Kit (item 11) to Front Support (item 3).
- 5.2 Set this assembly aside.

## Step 6 - Panel Installation

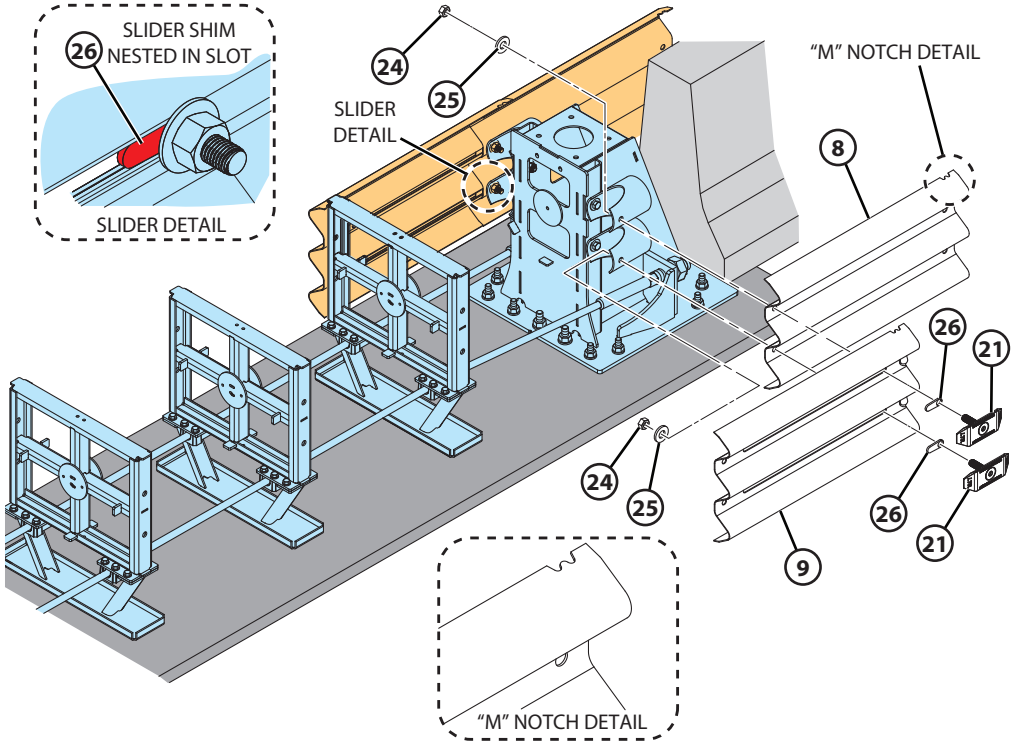

Item #	Part #	Description	QTY	
			TL-2	TL-3
8	BSI-1708030-00	End Panel, Thrie Beam, Galvanized, TAU-M	2	2
9	BSI-1708019-00	Sliding Panel, Galvanized, TAU-M	8	14
20	BSI-1809041-KT	Slider TAU-M Kit	4	7
21	K001003	TAU-II Slider Kit	4	7
22	BSI-1208032-00	SLIDER FLAT, GALV	16	28
23	2001788	C-Scr FSH 3/4-10 x 3" Gr5 GEOMET	16	28
24	2001789	NUT HN 3/4-10 Gr5 GEOMET	16	28
25	2001790	WASHER FLAT 3/4" STD GEOMET	16	28
26	BSI-1803016-00	Slider Shim, Geomet, TAU-M	16	28

6.1 Install an End Panel (item 8) to the End Panel Mounts with a Sliding Panel (item 9) lapped on the outside oriented with the "M" notch downstream.

**WARNING** Sliding Panel must be lapped over the End Panel.

## Step 6 (Cont.) - Panel Installation (Asphalt)

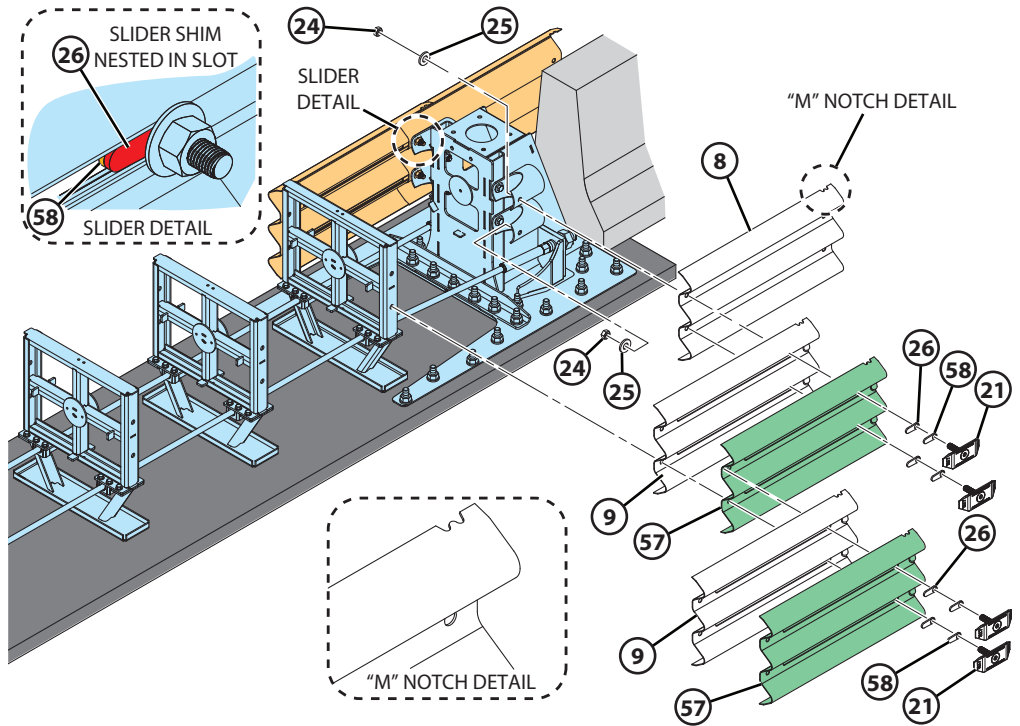

Item #	Part #	Description	QTY	
			TL-2	TL-3
57	BSI-1708019-00	Sliding Panel, Galvanized, TAU-M	0	4
58	BSI-1803016-00	Slider Shim, Geomet, TAU-M	0	8

**NOTE:** If the system is to be anchored into an asphalt foundation and is a TL-3 system, additional panels need to be nested in the last two (2) bays with double stacked Slider Shims (items 57 & 58). **TL-2 does not require nested panels in its asphalt installation.**

6.2 Install the preceding Sliding Panels (item 9) using the provided Slider Kit and Slider Shim (item 21 & 26) as shown. The hole on the Slider Shim must point downstream.  
**Hand tight only.**

**NOTE:** Ensure that the "M" notch is positioned downstream.

**PRO-TIP:** Use screw driver (flat or Phillips) to ensure Slider Shims seat in panel slot.

## Step 6 (Cont.) - Panel Installation

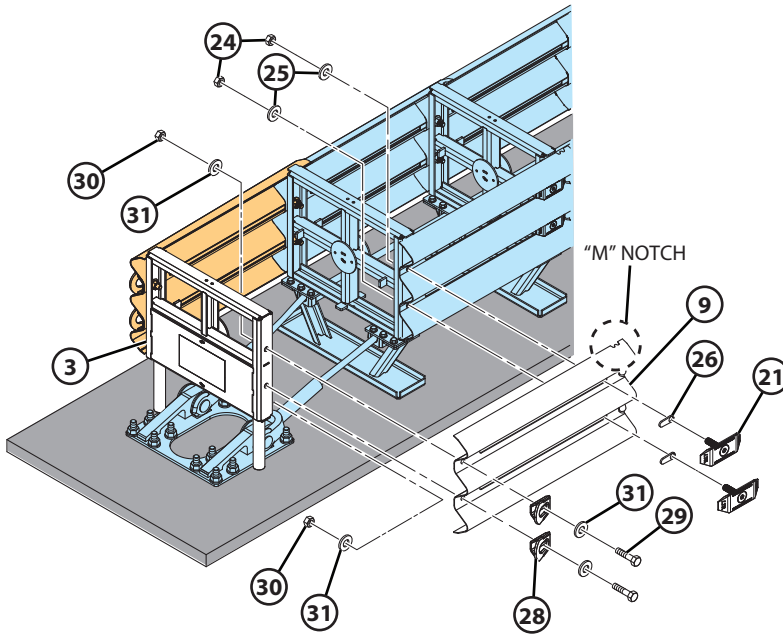

Item #	Part #	Description	QTY	
			TL-2	TL-3
27	BSI-1809040-KT	Tow Hook Kit, TAU-M	1	1
28	BSI-1711051-00	Tow Hook, Galvanized, TAU-M	4	4
29	2001795	C-Scr HH 3/4-10 x 2, Geomet	4	4
30	2001789	Nut HN, 3/4-10, Gr5, Geomet	4	4
31	2001790	Washer, 3/4" STD, Geomet	4	4

6.3 Progress to the next upstream Mid-Support and overlap the slots with the corresponding holes on the previous panel and secure with the Slider Kit and Slider Shim (item 21 & 26). Ensure that the Slider Shim is seated into the slot.

**⚠ WARNING** Proceeding panel must overlap on the outside.

6.4 Pull Midsupport upstream to ensure panel slots are fully extended.

6.5 Repeat step 6.3 as necessary for the appropriate test level as needed.

6.6 Once the last Mid-Support has been connected to the Slider Panels, the Front Support may now be installed to the front of the system in addition to the Tow Hook Kit (item 27). **Torque to 120 ft-lbs (160 N-m).**

**NOTE:** Tow Hooks have the crescent end facing upstream.

## Step 7 - Tether Kit Installation

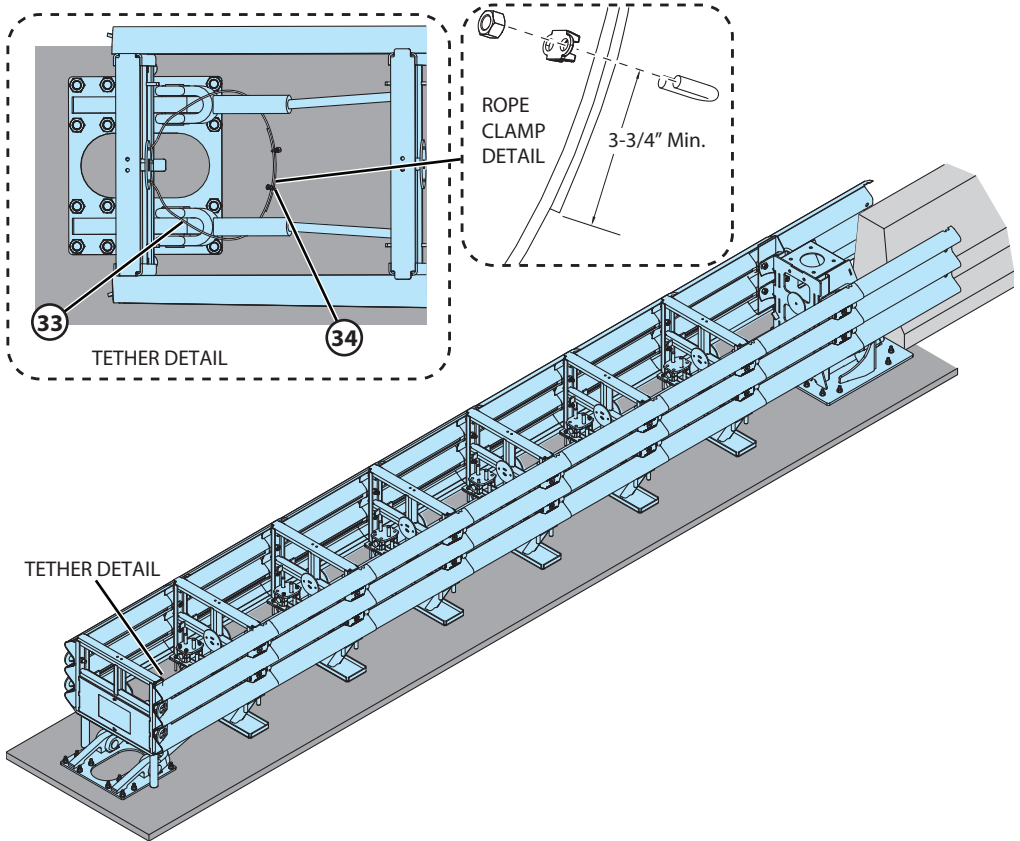

Item #	Part #	Description	QTY
32	BSI-1709083-KT	Tether Kit, TAU-M	1
33	4000316	3/16" Galvanized Tether	1
34	4000317	3/16" Galvanized Wire Rope Clamp	2

- 7.1 Loop the 3/16" diameter wire rope (item 33) through the Front Support frame as shown above and under the system Cable Assemblies as shown in the above illustration.
- 7.2 Overlap wire rope a minimum of 3-3/4" on both sides and secure the wire rope with the provided cable clamps (item 34). Ensure that the orientation of the cable clamp has the U-bolt on the side of the cut end of the wire rope.



## Step 8 - Delineation Bracket Installation

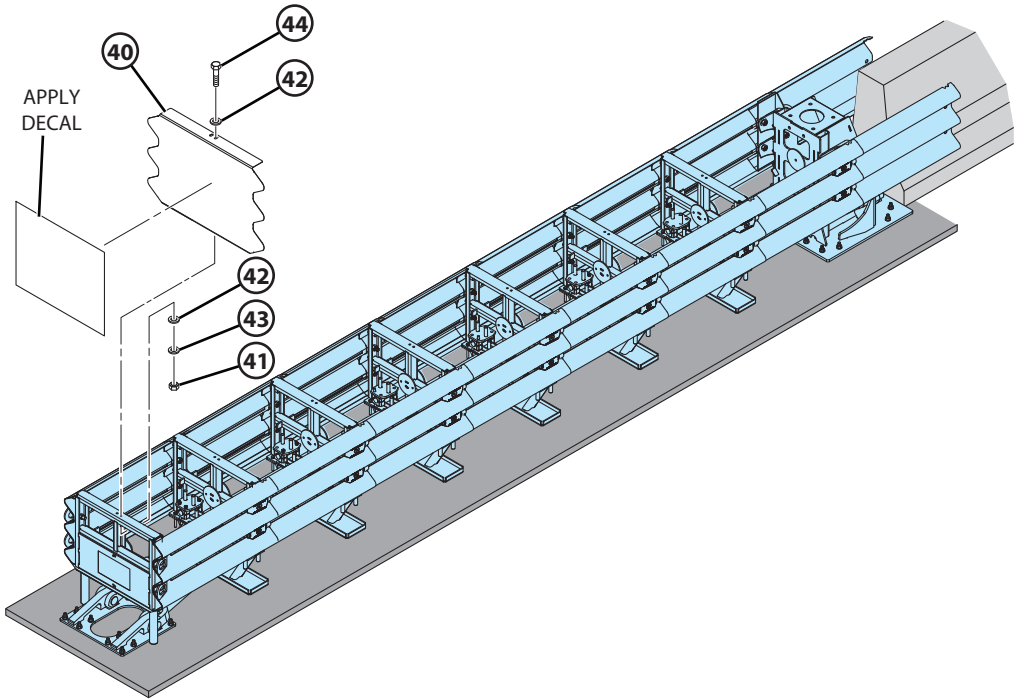

Item #	Part #	Description	QTY
39	BSI-1808034-KT	Delineation HW Kit, TAU-M	1
40	BSI-1708027-00	Bracket, Delineation, TAU-M	1
41	2001809	Nut HN 3/8-16, Gr5, Geomet	2
42	2001810	Washer 3/8" Std, Geomet	4
43	2001811	Washer SL 3/8" Std, Geomet	2
44	2001816	C-Scr HH 3/8-16 x 1-1/2", Gr5, Geomet	2

8.1 Attach Delineation Bracket (item 40) to the Front Support as shown.

**PRO-TIP:** Hook the bottom of the bracket under the Front Support frame first, then push the bracket flush to the Front Support face and align the delineation slot with the Front Support holes.

8.2 Secure with supplied hardware as shown.

8.3 Apply delineation decal as per Federal, State, or Local Standards.

## Step 9 - Energy Absorbing Cartridge Installation

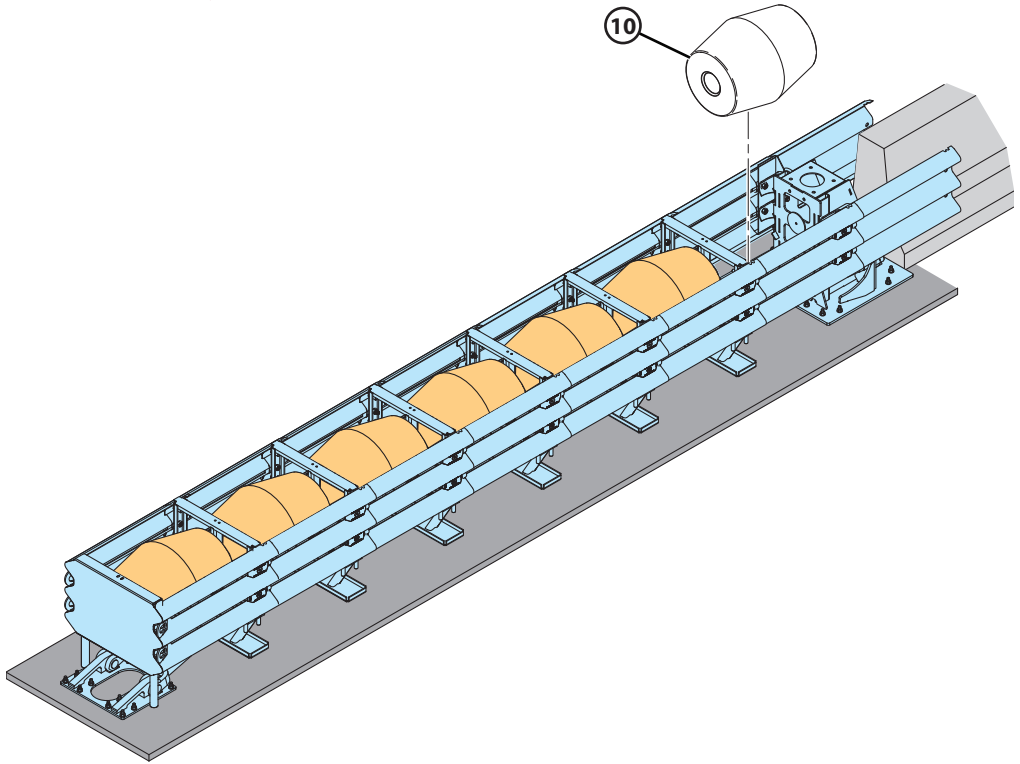

Item #	Part #	Description	QTY	
			TL-2	TL-3
10	B010722	Cartridge, TAU-II, Type B, Energy Absorbing	4	7

- 9.1 Drop in EACs (item 10) into each bay.
- 9.2 Ensure that the two venting holes are facing towards the backstop.
- 9.3 Ensure that the text "THIS SIDE UP" on cartridges is facing upward.

**⚠ WARNING** EACs must be seated fully onto the tabs in each bay and in the correct orientation.

## Step 10 - Torque Anchors and Cables (Concrete)

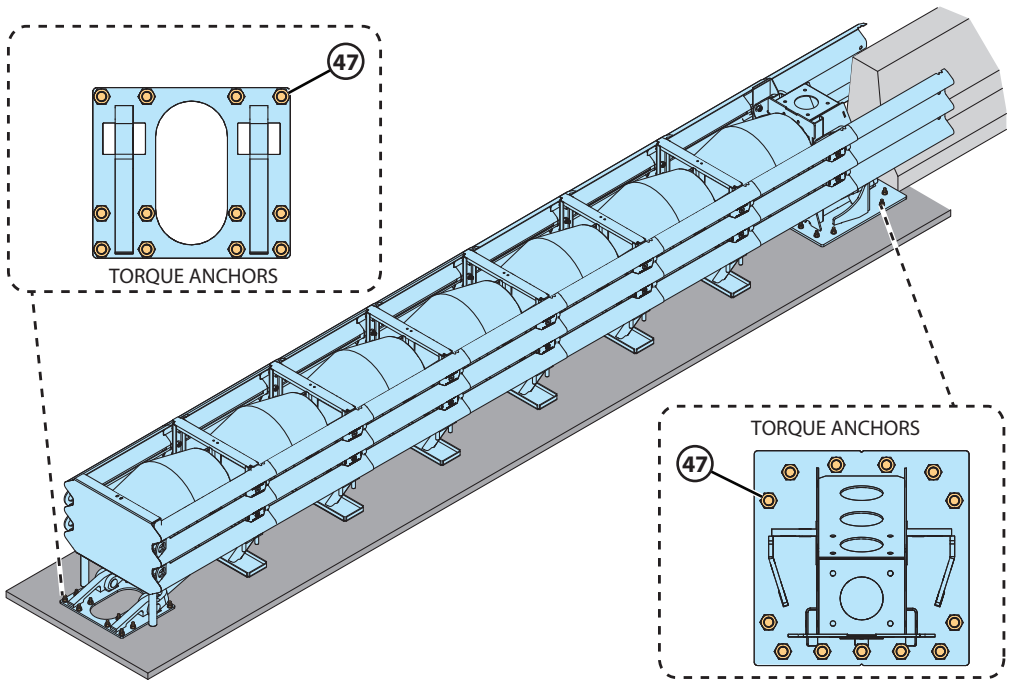

10.1 Ensure that the epoxy has cured per manufacturer's instruction. See epoxy cartridge.

10.2 Torque anchors to 120 ft-lbs (160 N-m).

**⚠ WARNING** Torque anchors to proper specifications.

## Step 10 (Cont.) - Torque Anchors and Cables (Asphalt)

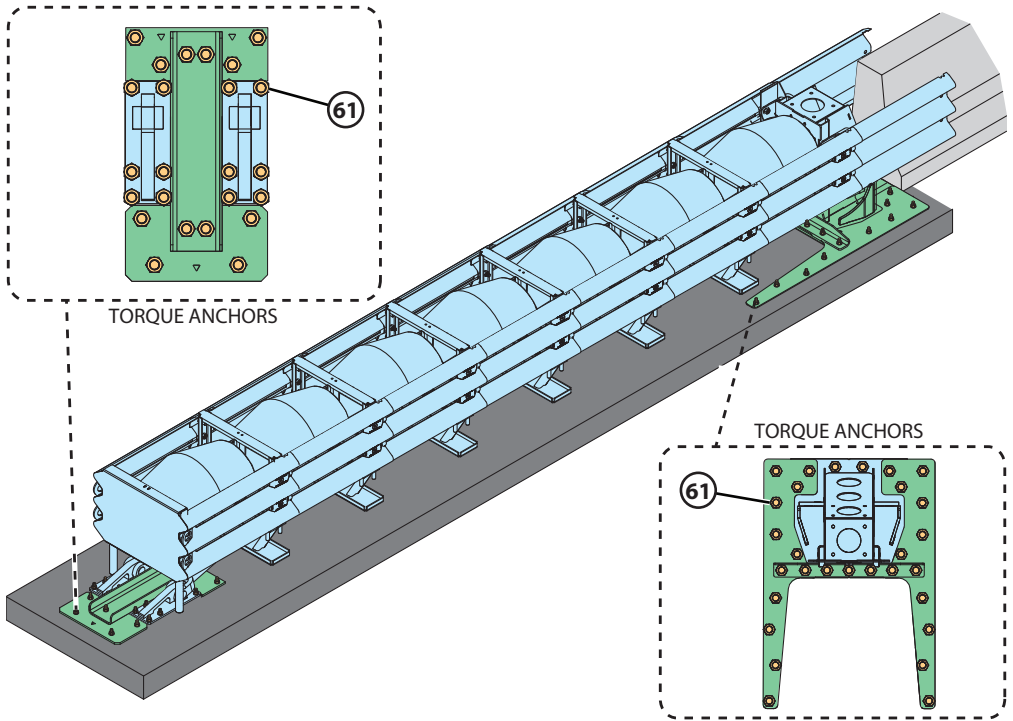

- 10.1 Ensure that the epoxy has cured per manufacturer's instruction. See epoxy cartridge.
- 10.2 **Torque anchors to 5 ft-lbs (8 N-m).**

**⚠ WARNING** Torque anchors to proper specifications.

## Step 10 (Cont.) - Torque Anchors and Cables

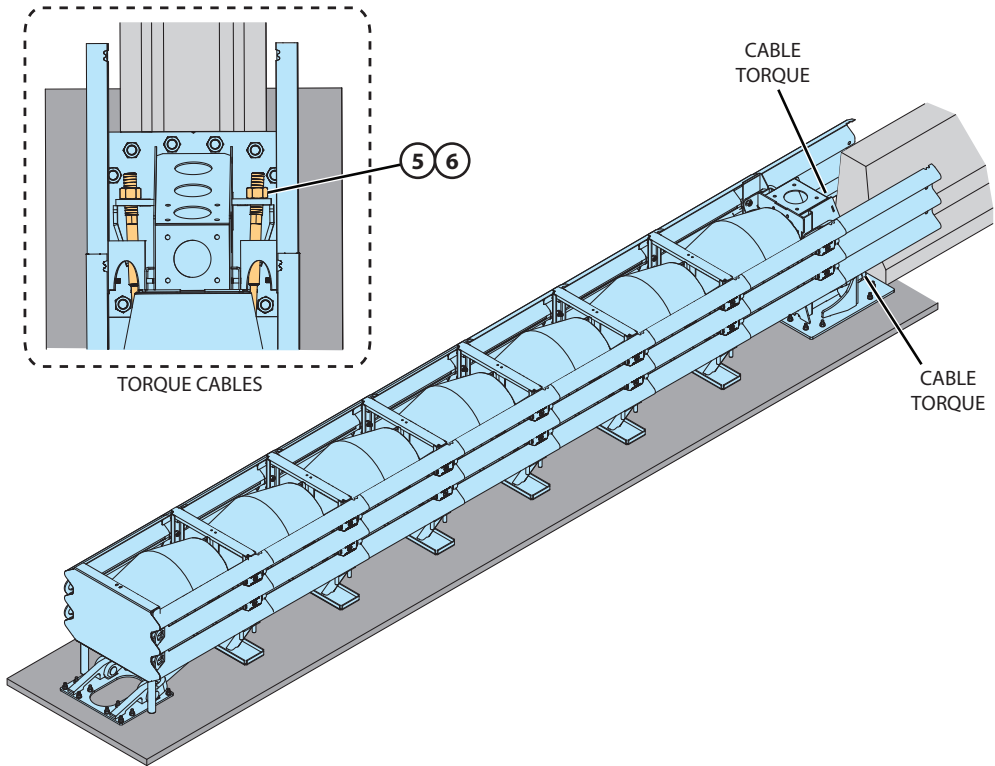

- 10.3 Ensure that the Cable Guides are fully seated and the clevis end of Cable Assemblies are secured to the Front Cable Anchor.
- 10.4 Use the provided socket and cable swage key (or pipe wrench of adequate size) to prevent Cable Assembly from spinning while tightening nut. Torque each Cable Assembly.

**⚠ DANGER TORQUE CABLES TO PROPER SPECIFICATIONS.**

Concrete	500 ft-lbs (680 N-m)
----------	----------------------

Asphalt	120 ft-lbs (160 N-m)
---------	----------------------

## Step 11 - Tighten Slider Bolts

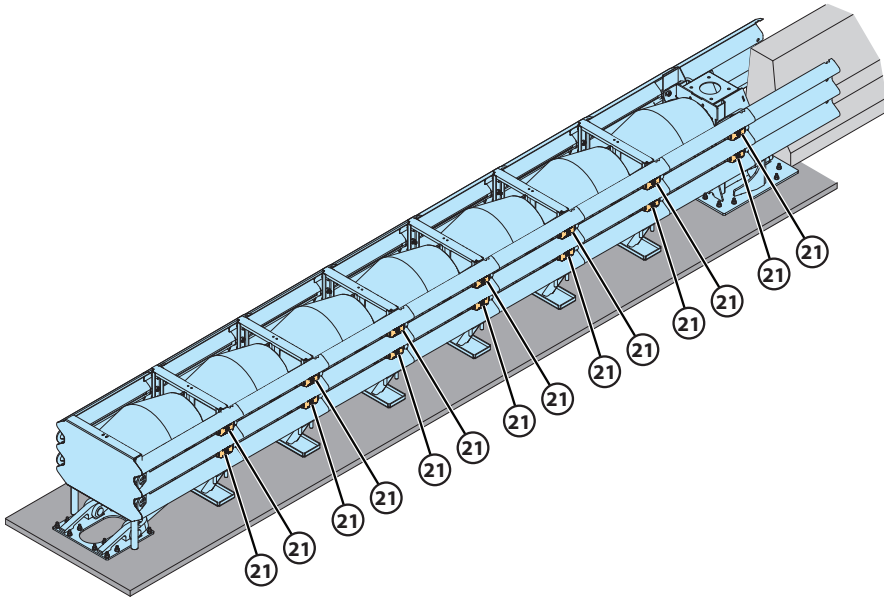

11.1 Using provided 1/2" Allen socket, tighten the Slider bolts on all Mid-Supports. There is no torque requirement for the Slider bolts. Ensure panels are fully nested.

**⚠ DANGER** PANELS MUST BE FULLY NESTED AND SLIDER BOLTS TIGHTENED TO ENSURE PROPER FUNCTION OF PANELS.

**PRO-TIP:** Use screw driver (flat or Phillips) to ensure Slider Shims seat in panel slot before tightening Slider bolts.

## Installing a Pre-Built System

TAU-M may be pre-assembled offsite and transported via flatbed truck and installed on location.

**NOTE:** Preassembled systems may be transported without EACs, with Mid-Supports fully collapsed.

**Preassemble System using Steps 1.1 and 2 through 9 of this manual.**

### Lifting the preassembled TAU-M™ System.

- Tighten all Slider bolts to add rigidity to system.
- Use chains connected to the top of Mid-Supports for lifting points. Steel posts or dunnage may be run through Mid-Supports, for added stability.
- Use crane, fork lift, or skid steer to lift the assembled system.

### Installing the preassembled TAU-M™ System

1. Drilling anchor holes
  - I. Use a drilling template for the backstop and Front Cable Anchor prior to placement.

**OR**

  - II. Place system on location and mark anchor hole locations.
  - III. Move system aside to drill holes.

**OR**

  - IV. Place system on location.
  - V. Ensure spacing between backstop and Front Cable Anchor is correct.
  - VI. Remove first and last bay cartridges to access anchor hole locations.
    - a. Use 4 – 5 ft. drill bit or extension to access anchor holes through the End Panel Mounts as shown.

**PRO-TIP:** Loosening the Slider bolt that is connected to the End Panel Mounts, will make for easier access.

2. Follow Step 1 of this manual, see page 21.
3. Replace EACs in first and last bay, if removed for drilling accessibility.

## Installing a Pre-Built System (Cont.)

### Completed System Dimensions

Max Dimension	System Configuration	
	TL-2	TL-3
Height	32-5/8" (0.83m)	32-5/8" (0.83m)
Width	34-1/2" (0.88m)	34-1/2" (0.88m)
Length	185" (4.7m)	287" (7.3m)
Asphalt Kit Width	43" (1.1m)	43" (1.1m)
Asphalt Kit Length	197" (5.0m)	300" (7.6m)

### Approximate System Weight

System Configuration	Weight:	With Asphalt Kit
TL-2	1700 lbs. (3750 kg)	1950 lbs. (4300 kg)
TL-3	2500 lbs. (5500 kg)	2950 lbs. (6500 kg)

\*Weight does not include transition components or anchoring hardware.

## Upgrade a TAU-II System to a TAU-M System

TAU-M™ is designed with the intent to be a kit-able system, where existing TAU-II systems (tested to NCRHP 350) can be converted to the MASH system by swapping out certain components.

Listed are the components from the TAU-II system that may be used in the TAU-M system.

- Compact Backstop, only for concrete applications. **Asphalt must use TAU-M Compact Backstop**
- Mid-Supports
- Front Support Assembly
- Slider Kits
- Pipe Panel Mounts
- Type B EACs

In addition to the reusable TAU-II components, include all parts in the appropriate 350 to MASH Upgrade Kit, found on page 15.



## Upgrade a TAU-II System to a TAU-M System (Cont.)

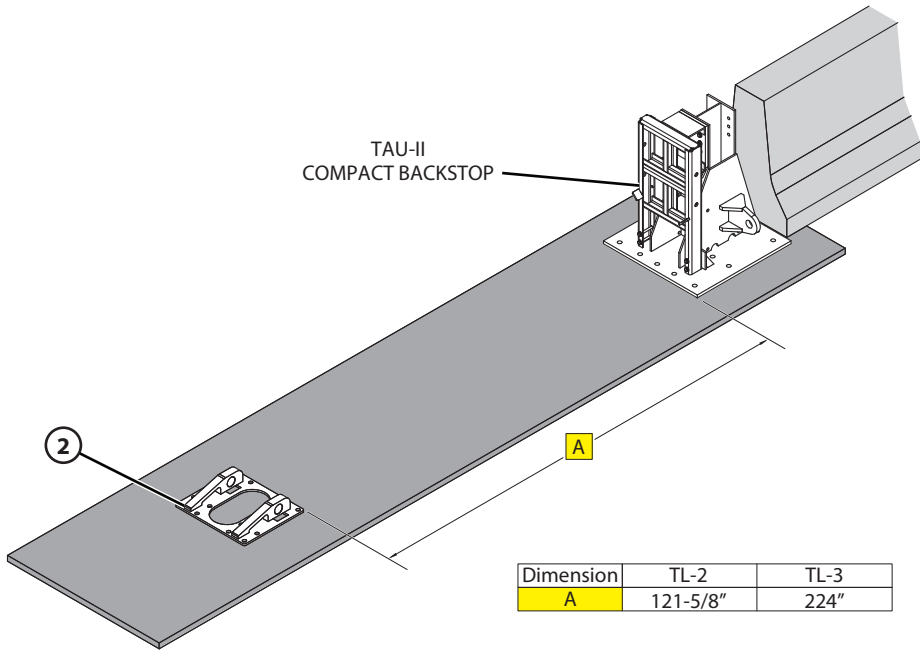

The following steps must be followed to convert a TAU-II system to a TAU-M system.

Step 1. Disassemble TAU-II system.

- When installing in concrete, the TAU II Compact Backstop with existing End Panel Mounts may be utilized.
- When installing in asphalt, attach the End Panel Mounts to the TAU-M Compact Backstop.

Step 2. Replace TAU-II Front Cable Anchor with TAU-M Front Cable Anchor (item 2).

- Position away from the front of the Compact Backstop base plate according to the above table.

## Upgrade a TAU-II System to a TAU-M System (Cont.)

Step 3. Reduce or increase number of bays compliant with the TAU-M Test Level.

- TL-2 = 4 Bays (3 Mid-Supports)
- TL-3 = 7 Bays (6 Mid-Supports)

Step 4. Replace Cable Assemblies with MASH compliant Cable Assemblies (1-1/8" diameter)

Step 5. Install MASH Cable Guides (single piece) using the provided hardware.

Step 6. Replace TAU-II panels with the TAU-M (indicated by "M" notch) Sliding and End Panels, using the existing Slider Kits and TAU-M Slider Shims (item 26).

- Follow step 6 of page 29 for installation instructions.

Step 7. Replace Type A cartridges with Type B cartridges.

Step 8. Follow Steps 9, 10, and 11 from TAU-M on pages 34 through 38.

### Asphalt Applications

For asphalt applications the TAU-M requires the use of the TAU-M backstop in addition to the parts listed on the 350 to MASH Upgrade Kit – Asphalt BOM on page 16. **DO NOT USE TAU-II Backstop in asphalt applications.**

## Inspector Checklist

Confirm all items in the checklist have been properly completed and hardware is tightened.

### Concrete Installation Checklist

Inspection		
Date	By	Item
		Delineation Bracket is attached to Front Support. (Step 8, Page 33.)
		Ensure Tether Kit is installed. With 3-3/4" minimum on each side of cable clamp. (Step 7, Page 32.)
		Tow Hooks are installed with crescent end facing upstream. (Step 6, Page 31.)
		Anchor spacing, 121- 5/8" (TL-2), 224" (TL-3) between base plates of Front Cable Anchor and Compact Backstop. (Step 1, Page 21.)
		Cable Guides are seated flush on Mid-Support Assemblies. (Step 4, Page 27.)
		Cable Guide Torque 30 ft-lbf (48 N-m). (Step 4, Page 27.)
		Slider Panel lapping with "M" notch downstream side towards backstop. (Step 6, Page 29.)
		Slider Panels must overlap the preceding downstream panel on outside. (Step 6, Page 31.)
		Slider Shims are nested in the panel slots. (Step 6, Page 29.)
		Slider bolts are tightened. (Step 11, Page 38.)
		End Panel Mounts are parallel to the end panels with "U" cut out facing upstream. (Step 2, Page 25.)
		End Panel Mount torque spec. 70 ft-lbf (95 N-m). (Step 2, Page 25.)
		Cables are torqued to 500 ft-lbf (680 N-m). No visible sagging. (Step 10, Page 37.)
		EACs are seated correctly on tabs. (Step 9, Page 34.)
		Text on the EACs are facing upward, two vent holes facing towards backstop. (Step 9, Page 34.)
		Anchor bolts torque to 120 ft-lbs (160 N-m). (Step 10, Page 35.)
Inspector signature:		Date:

## Asphalt Installation Checklist

This check list is in addition to the above checklist.

Inspection		
Date	By	Item
		Rear Plate and Tie Channel are anchored flush to the foundation. (Step 1, Page 22.)
		For TL-3 systems Bays 6 & 7 have nested panels and stacked Slider Shims. (Step 6, Page 30.)
		Backstop Braces are anchored flush to the foundation. (Step 1, Page 24.)
		Crossmember is seated flush on top of Compact Backstop and Backstop Braces. (Step 1, Page 22.)
		Anchor bolts torqued to 5 ft-lbf (8 N-m). (Step 10, Page 36.)
		Cables torqued to 120 ft-lbf (160 N-m). (Step 10, Page 37.)
Inspector signature:		Date:

## Maintenance Inspection

Crash cushions, like all roadside safety hardware, require inspection to ensure they are in acceptable working condition. Regular inspections of the TAU-M™ system is recommended and shall be made by the local highway authority. Frequency of the inspections shall be made based on site conditions, traffic volumes, and crash history. Please follow the local guidelines for frequency of inspections to ensure adequate repairs are made to the system. Walk-up inspections are recommended at least twice a year. The TAU-M™ system shall be inspected for damage after every impact. Repairs shall be made accordingly using Lindsay Transportation Solutions components as specified in the product drawings.

## Visual Drive-By Inspections (Recommended Frequency – Monthly)

Check for:

- Damage caused by vehicle impacts
- Minor damage cause by impacts from roadside maintenance equipment
- Misalignment of panels
- Missing components
- Damage from vandalism

---

## Maintenance Inspection (Cont.)

### Walk-Up Inspections (Recommended Frequency – Twice a Year)

Before performing walk-up inspections, ensure traffic control is deployed in accordance with local guidelines.

Check for:

- Damage caused by vehicle impacts
- Damage caused by impacts from roadside maintenance equipment
- Misalignment of panels
- Missing components
- Vandalism
- Sagging cables
- Clear and dispose of any debris in and around the system
- Frayed cable
- Loose hardware

After inspection is complete, ensure all items identified during the inspection process are corrected. The TAU-M™ system shall be returned to proper condition as outlined in the installation instructions.

## Maintenance Inspection (Cont.)

Walk-Up Inspection	
Item	Comment
Damage caused by vehicle impacts	
Minor damage caused by impacts from roadside maintenance equipment	
Misalignment of panels	
Missing components	
Vandalism	
Sagging cables	
Clear and dispose of any debris in and around the system	
Grading around system	
Loose hardware	
Inspector Signature:	Date:
Print Name:	Location:

# Drawings FOUNDATION SPECIFICATIONS

## FOUNDATION SPECIFICATIONS:

THE TAU-II CRASH CUSHION SYSTEM HAS BEEN DESIGNED TO ATTACH TO CONCRETE OR ASPHALT FOUNDATIONS. USE THE ANCHORAGE SPECIFIED BELOW DEPENDING ON THE FOUNDATION AT THE JOB SITE. REFERENCE UNIVERSAL TAU-II FOUNDATION DRAWINGS FOR FURTHER DETAIL.

### MATERIAL SPECIFICATIONS

#### PORTLAND CEMENT CONCRETE (PCC)

STONE AGGREGATE CONCRETE (MK, 4,000 PSI) (28 MPa) MINIMUM COMPRESSIVE STRENGTH (SAMPLING PER ASTM C31-84 OR ASTM C661-84A, TESTING PER ASTM C38-94)

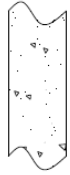

#### ASPHALTIC CONCRETE (AC)

AR-4000 A.C. (PER ASTM D3881 '83) 75% MAXIMUM MEDIUM (TYPE A OR B) AGGREGATE

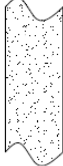

SIEVE SIZE	% PASSING
1"	100
3/4"	85-100
3/8"	65-80
No. 4	48-54
No. 8	38-40
No. 16	28-21
No. 200	3-5

#### COMPACTED SUBBASE (DGA)

6 IN. (150 mm) MINIMUM DEPTH, 95% COMPACTION, CLASS 2 AGGREGATE

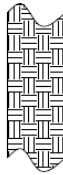

SIEVE SIZE	% PASSING
3"	100
2 1/2"	90-100
No. 4	60-90
No. 200	0-25

#### 1.) CONCRETE PAD

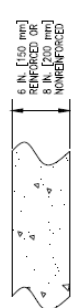

FOUNDATION: MINIMUM 6 IN. (150 mm) REINFORCED PCC PAD OR 8 IN. (200 mm) NONREINFORCED PCC PAD  
ANCHORAGE: 3/4 IN. (20 mm) X 1/2 IN. (12.5 mm) GALVANIZED ANCHOR WITH 6 IN. (150 mm) EMBEDMENT

#### 2.) ASPHALT OVER SUBBASE

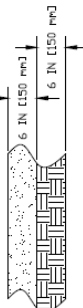

FOUNDATION: MINIMUM 6 IN. (150 mm) AC OVER 6 IN. (150 mm) COMPACTED DGA SUBBASE  
ANCHORAGE: 3/4 IN. (20 mm) X 1/2 IN. (12.5 mm) GALVANIZED ANCHORS WITH 16 IN. (400 mm) EMBEDMENT  
ASPHALT ANCHORING KIT REQUIRED

#### 3.) ASPHALT ONLY

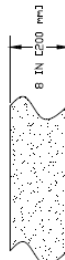

FOUNDATION: MINIMUM 8 IN. (200 mm) AC  
ANCHORAGE: 3/4 IN. (20 mm) X 1/2 IN. (12.5 mm) GALVANIZED ANCHORS WITH 16 IN. (400 mm) EMBEDMENT  
ASPHALT ANCHORING KIT REQUIRED

#### 4.) ASPHALT OVER P.C. CONCRETE



FOUNDATION: AC OVER PCC  
ANCHORAGE: 3/4 IN. (20 mm) GALVANIZED ANCHORS WITH MINIMUM 6 IN. (150 mm) EMBEDMENT IN PCC - ASPHALT ANCHORING KIT NOT REQUIRED  
OR  
IF 6 IN. (150 mm) EMBEDMENT IN PCC IS NOT POSSIBLE USE 3/4 IN. (20 mm) X 1/2 IN. (12.5 mm) GALVANIZED ANCHORS WITH 18 IN. (450 mm) EMBEDMENT - ASPHALT ANCHORING KIT REQUIRED

SCALE: FULL	Standard Tolerance	Model	Drawing Number	Rev.
DRAWN BY: 07/09/04 CAD	Angular ± 1/2°	A040113	A	
CHECKED BY: JSK	Fractional ± 1/16	FOUNDATION SPECIFICATIONS		
TITLE: FOUNDATION SPECIFICATIONS	Dec. .XXX = ± .010			
DATE: 03/02/04 CAD	Dec. .XXX = ± .050			
BY: DATE: REV: 0	ITEM: REQ'D: NEXT ASSY:			
SEE ECN 00589	CHANGES:			

# Drawings TAU-M FOUNDATION COMPACT BACKSTOP

Last Saved by: jaronm; Friday, August 31, 2018 8:10:35 AM

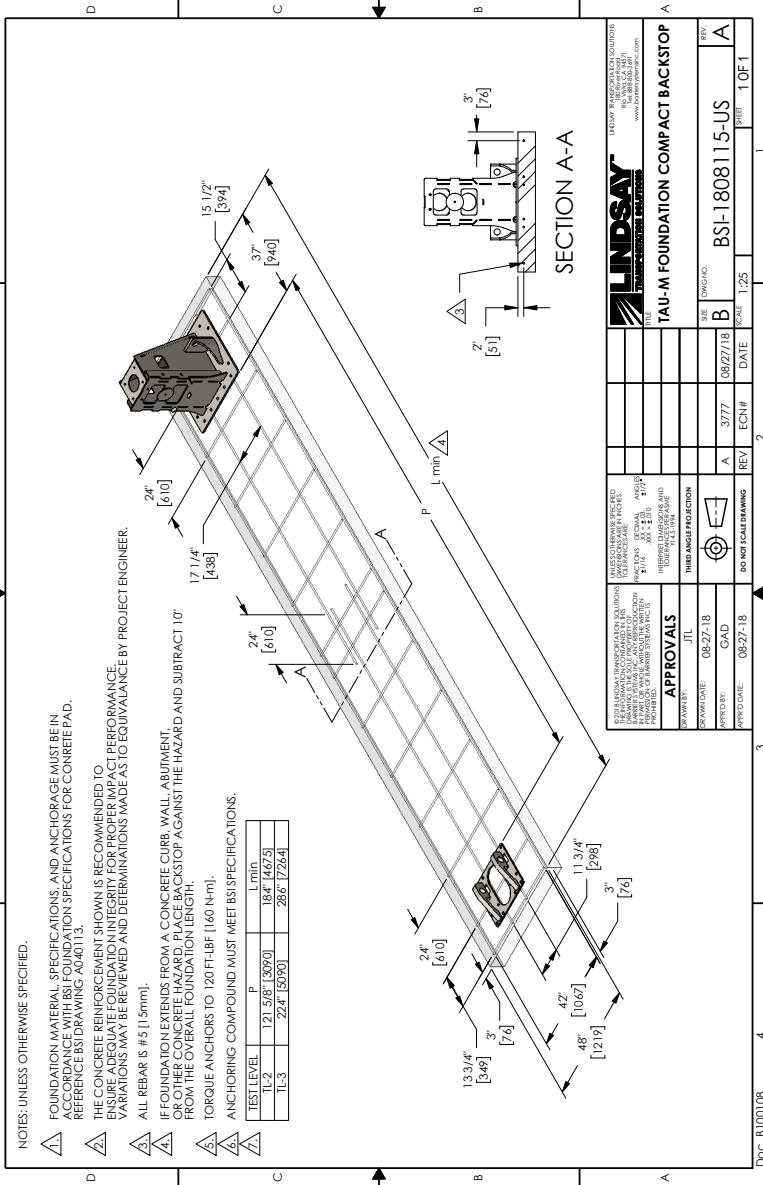

Doc. B1001.08



# Drawings UNIVERSAL TAU-M TL-3

last saved by: jason.finn Monday, August 27, 2018 10:42:03 AM

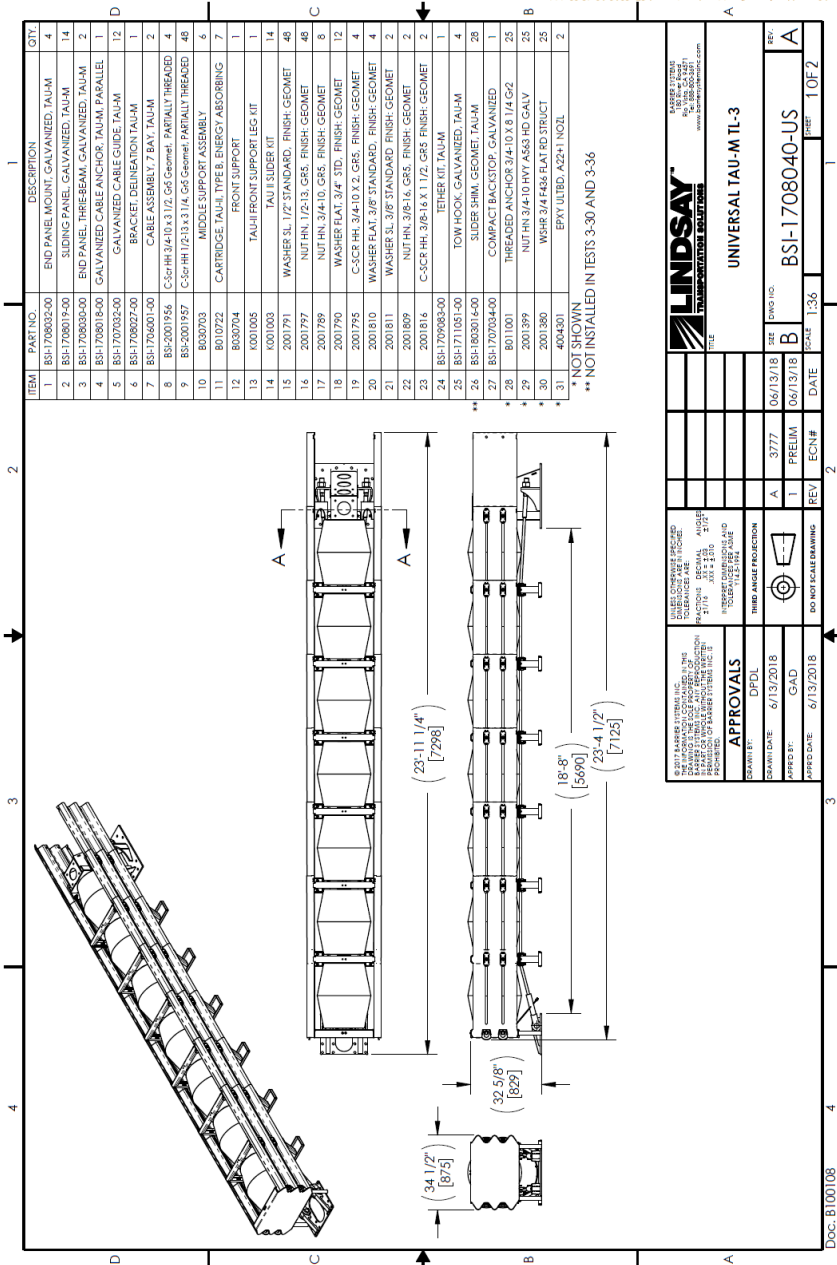

ITEM	PARTNO.	DESCRIPTION	QTY.
1	BSH-708032-00	END PANEL MOUNT, GALVANIZED, TAU-M	4
2	BSH-708019-00	SLIDING PANEL, GALVANIZED, TAU-M	14
3	BSH-708030-00	END PANEL, THREE-BEAM, GALVANIZED, TAU-M	2
4	BSH-708018-00	GALVANIZED CABLE ANCHOR, TAU-M, PARALLEL	1
5	BSH-707033-00	GALVANIZED CABLE GUIDE, TAU-M	12
6	BSH-708027-00	BRACKET, DESIGNATION TAU-M	1
7	BSH-706001-00	CABLE ASSEMBLY, 7 BAN, TAU-M	2
8	BSH-200195SS	C35r-HH 3/4-10 X 3 1/2, GR5, GEOMET, PAFK PAULT, THREADED	4
9	BSH-200195T	C35r-HH 1/2-13 X 3 1/4, GR5 GEOMET, PAFK PAULT, THREADED	48
10	8030703	MIDDLE SUPPORT ASSEMBLY	6
11	8010722	CARRIAGE, TAU-M, TYPE B, ENERGY ABSORBING	7
12	8030704	FRONT SUPPORT	1
13	K001005	TAU-H FRONT SUPPORT LEC KIT	1
14	K001003	TAU H SLIDER KIT	14
15	2001791	WASHER SL, 1/2" STANDARD, FINISH: GEOMET	48
16	2001797	NUT HN, 1/2-13, GR5, FINISH: GEOMET	48
17	2001789	NUT HN, 3/4-10, GR5, FINISH: GEOMET	8
18	2001790	WASHER FLAT, 3/4", STD, FINISH: GEOMET	12
19	2001795	C35CR HH, 3/4-10 X 3, GR5, FINISH: GEOMET	4
20	2001810	WASHER FLAT, 3/8" STANDARD, FINISH: GEOMET	4
21	2001811	WASHER SL, 3/8" STANDARD, FINISH: GEOMET	2
22	2001899	NUT HN, 3/8-16, GR5, FINISH: GEOMET	2
23	2001816	C35CR HH, 3/8-16 X 1 1/2, GR5, FINISH: GEOMET	2
24	BSH-1709833-00	TETHER KIT, TAU-M	1
25	BSH-1711051-00	TOW HOOK, GALVANIZED, TAU-M	4
26	BSH-803014-00	SLIDER 3HM, GEOMET, TAU-M	28
27	BSH-707034-00	COMPACT BACKSTOP, GALVANIZED	1
28	8011001	THREADED ANCHOR 3/4-10 X 9 1/4 G-2	25
29	2001899	NUT HN 3/4-10 HWY A563 HD GALV	25
30	2001380	WHR 3/4-14 1/2 FLAT RD, STRUCT	25
31	4040301	EPXY ULTRD, R22H, NOZL	2

\*\* NOT INSTALLED IN TESTS 3-30 AND 3-36

		<b>UNIVERSAL TAU-M TL-3</b>	
DATE	REV.	DATE	REV.
06/13/2018	A	06/13/2018	A
06/13/2018	B	06/13/2018	B
06/13/2018	1	06/13/2018	1
06/13/2018	2	06/13/2018	2
06/13/2018	3	06/13/2018	3
06/13/2018	4	06/13/2018	4
06/13/2018	5	06/13/2018	5
06/13/2018	6	06/13/2018	6
06/13/2018	7	06/13/2018	7
06/13/2018	8	06/13/2018	8
06/13/2018	9	06/13/2018	9
06/13/2018	10	06/13/2018	10
06/13/2018	11	06/13/2018	11
06/13/2018	12	06/13/2018	12
06/13/2018	13	06/13/2018	13
06/13/2018	14	06/13/2018	14
06/13/2018	15	06/13/2018	15
06/13/2018	16	06/13/2018	16
06/13/2018	17	06/13/2018	17
06/13/2018	18	06/13/2018	18
06/13/2018	19	06/13/2018	19
06/13/2018	20	06/13/2018	20
06/13/2018	21	06/13/2018	21
06/13/2018	22	06/13/2018	22
06/13/2018	23	06/13/2018	23
06/13/2018	24	06/13/2018	24
06/13/2018	25	06/13/2018	25
06/13/2018	26	06/13/2018	26
06/13/2018	27	06/13/2018	27
06/13/2018	28	06/13/2018	28
06/13/2018	29	06/13/2018	29
06/13/2018	30	06/13/2018	30
06/13/2018	31	06/13/2018	31

<b>APPROVALS</b> DRAWN BY: DPDL CHECKED BY: GAD DATE: 6/13/2018	THIRD ANGLE PROJECTION 	REV. ECN# 1 PRELIM 2	DATE 06/13/2018 06/13/2018	PART 1-36	REF. 1 OF 2
--	----------------------------	----------------------------	----------------------------------	--------------	-------------

Doc: B100108

# Drawings UNIVERSAL TAU-M TL-3

East: Saved by: jason.lms; Monday, August 27, 2018 10:42:03 AM

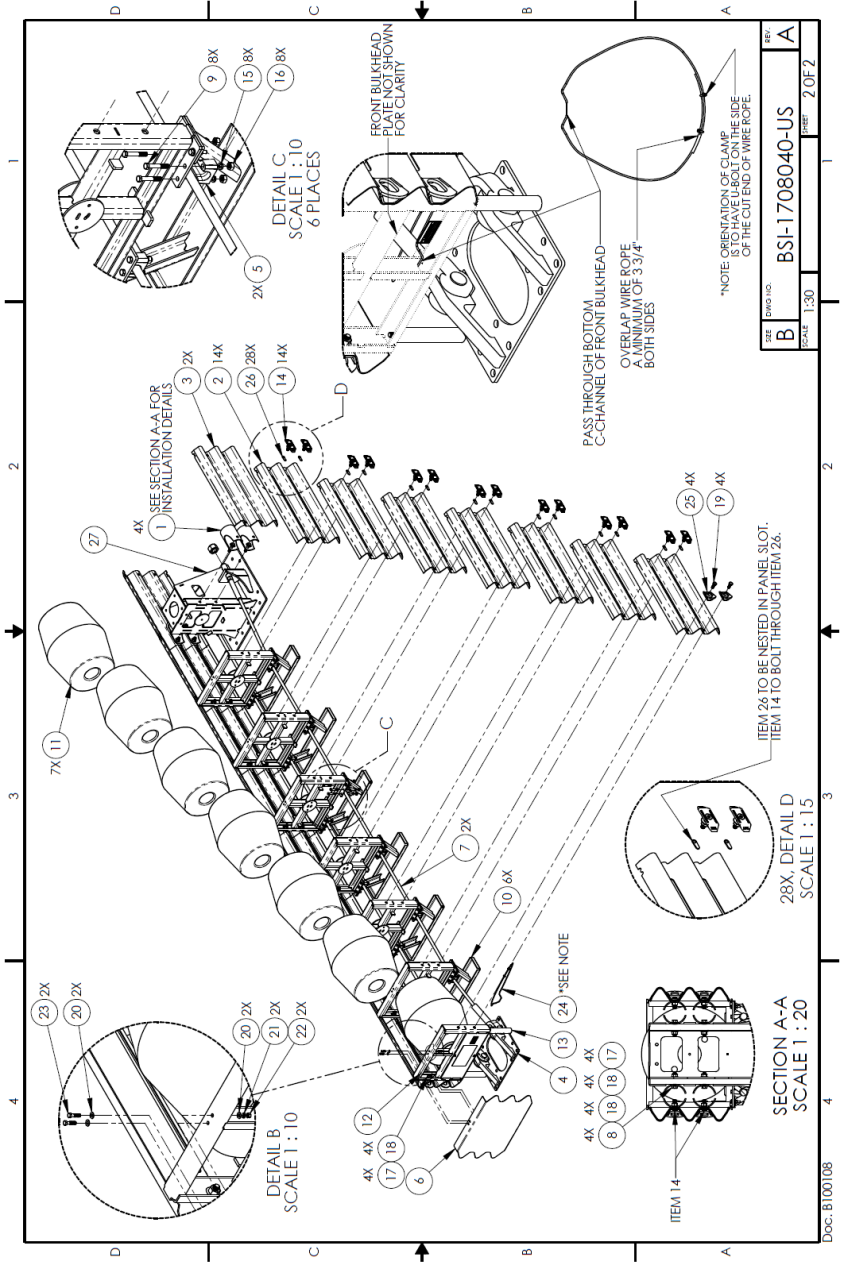

Doc: B100108

# Drawings UNIVERSAL TAU-M TL-2

Left: Covered by: jason.lindsay@lindsay.com Tuesday, August 28, 2018 1:48:53 PM

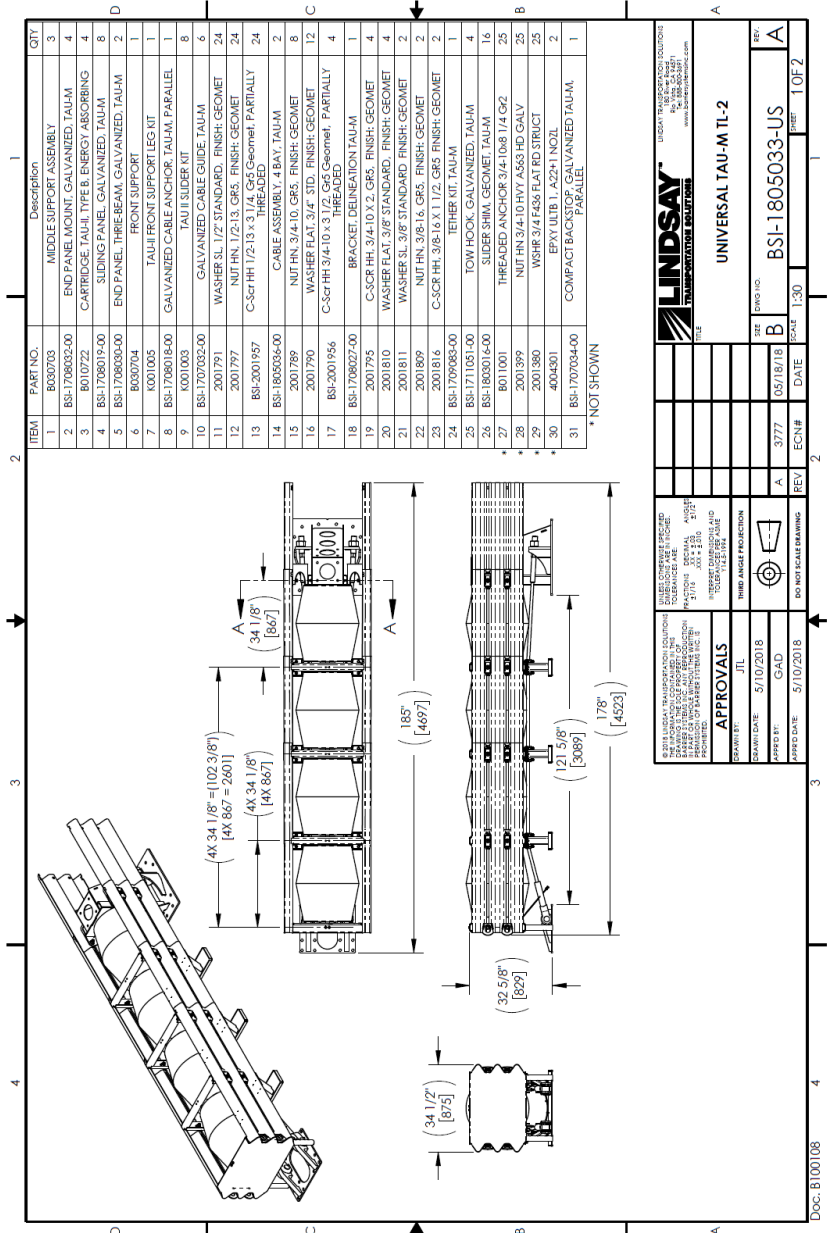

ITEM	PART NO.	Description	QTY
1	8007103	MIDDLE SUPPORT ASSEMBLY	3
2	BS1170802-00	END PANEL MOUNT, GALVANIZED, TAU-M	4
3	8010722	CARTRIDGE, TAU-M, TYPE B, ENERGY ABSORBING	4
4	BS11708019-00	SLIDING PANEL, GALVANIZED, TAU-M	8
5	BS11708030-00	END PANEL, THREE-BEAM, GALVANIZED, TAU-M	2
6	8007004	FRONT SUPPORT	1
7	K001005	TAU-M FRONT SUPPORT LEGS KIT	1
8	BS11708018-00	GALVANIZED CABLE ANCHOR, TAU-M, PARALLEL	1
9	K001003	TAU-M SLIDER KIT	8
10	BS11707032-00	GALVANIZED CABLE GUIDE, TAU-M	6
11	2001791	WASHER SL, 1/2\" STANDARD, FINISH: GEOMET	24
12	2001797	NUT HN, 3/4-10, GR5, FINISH: GEOMET	24
13	BS1-2001957	C-SCR HH, 1/2-13 x 3 1/4, G5 Geomet, PARTIALLY THREADED	24
14	BS1-1805036-00	CABLE ASSEMBLY, 4 BAY, TAU-M	2
15	2001789	NUT HN, 3/4-10, GR5, FINISH: GEOMET	8
16	2001790	WASHER FLAT, 3/4\" STD, FINISH: GEOMET	12
17	BS1-2001956	C-SCR HH, 3/4-10 x 3 1/2, G5 Geomet, PARTIALLY THREADED	4
18	BS11708027-00	BRACKET, DELINEATION TAU-M	1
19	2001795	C-SCR HH, 3/4-10 X 2, GR5, FINISH: GEOMET	4
20	2001810	WASHER FLAT, 3/8\" STANDARD, FINISH: GEOMET	4
21	2001811	WASHER SL, 3/8\" STANDARD, FINISH: GEOMET	2
22	2001809	NUT HN, 3/8-16, GR5, FINISH: GEOMET	2
23	2001816	C-SCR HH, 3/8-16 X 1 1/2, GR5 FINISH: GEOMET	2
24	BS11709083-00	TEHER KIT, TAU-M	1
25	BS11711051-00	TOW HOOK, GALVANIZED, TAU-M	4
26	BS11803016-00	SLIDER SHIM, GEOMET TAU-M	16
27	8011001	THREADED ANCHOR 3/4-10# 1/4 G2	25
28	2001399	NUT HN 3/4-10 HWY, A563 HD, GALV	25
29	2001380	WSHR 3/4 E438 FLAT, EDO, STRUCT	25
30	40014001	EPXY ULTR. 1, A22H1, NOZL	2
31	BS11707034-00	COMPACT BACKSTOP, GALVANIZED TAU-M, PARALLEL	1

\*NOT SHOWN

		UNIVERSAL TAU-M TL-2	
TITLE	SIZE	DATE	SHEET
UNIVERSAL TAU-M TL-2	B	05/18/18	1 OF 2
ECN#	DATE	ECN#	DATE
A	3777	B	1-30
APPROVALS			
DRAWN BY: JTL	CHECKED BY: GAD	DATE: 5/10/2018	DATE: 5/10/2018
DO NOT SCALE DRAWING			

**Drawings** UNIVERSAL TAU-M TL-2

Lost Saved by: jpsm\jlm Tuesday, August 23, 2016 1:48:53 PM

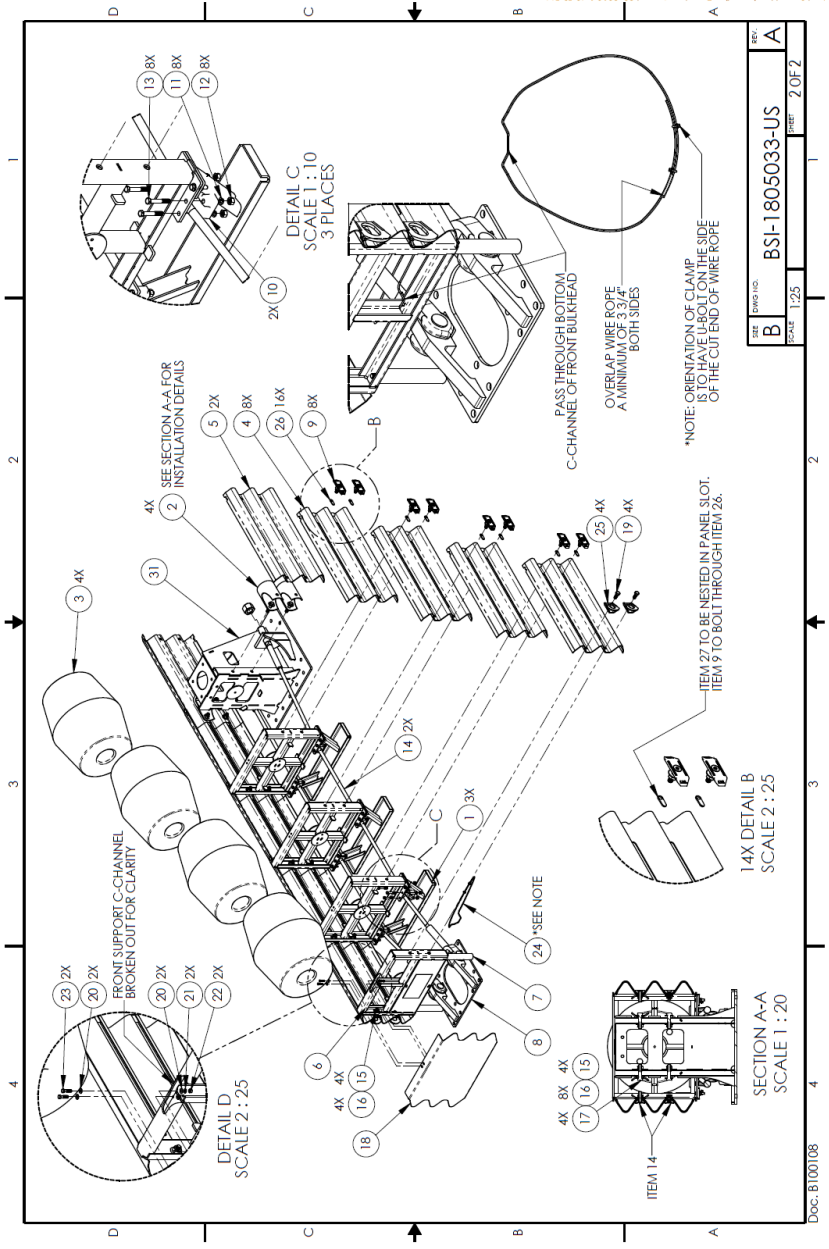

# Drawings ASPHALT ANCHOR KIT

Last Saved by: Jason Jmt; Wednesday, July 23, 2018 11:43:11 AM

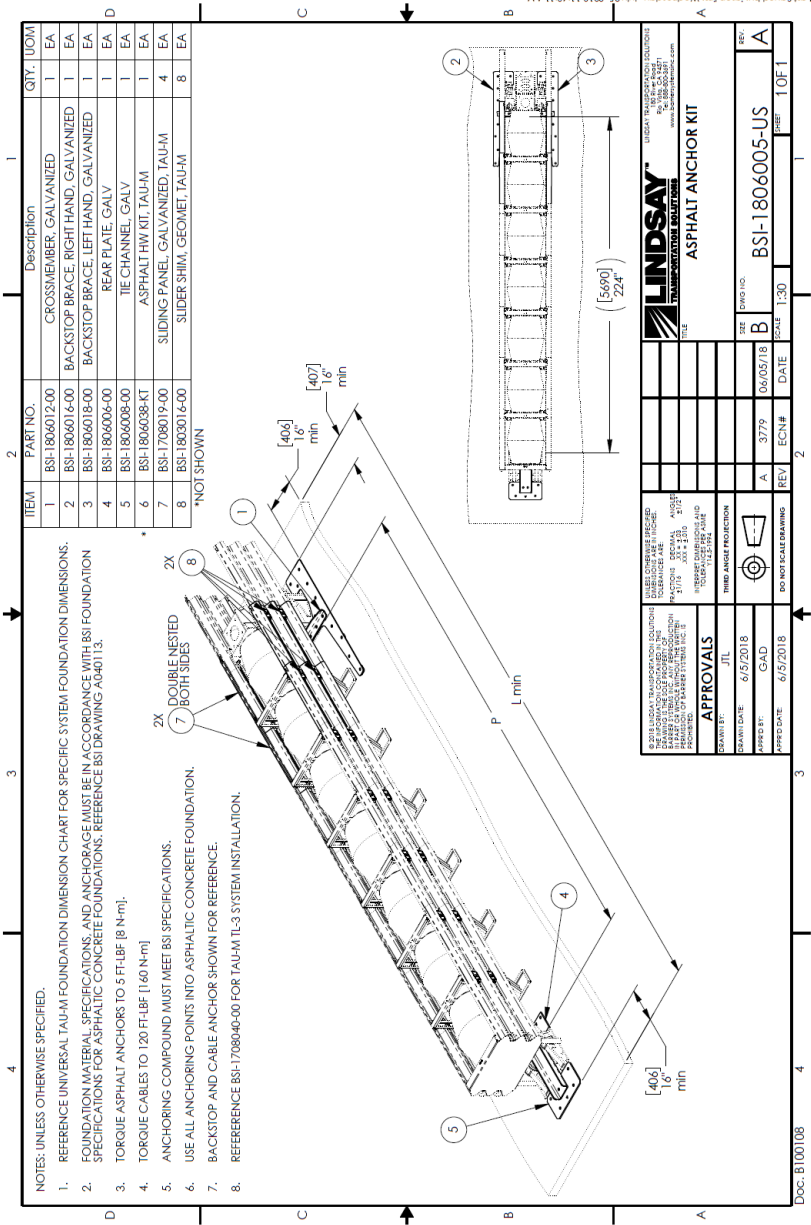

- NOTES: UNLESS OTHERWISE SPECIFIED:  
 REFERENCE UNIVERSAL TAU-M FOUNDATION DIMENSION CHART FOR SPECIFIC SYSTEM FOUNDATION DIMENSIONS.  
 FOUNDATION MATERIALS, SPECIFICATIONS, AND ANCHORAGE MUST BE IN ACCORDANCE WITH BSI FOUNDATION SPECIFICATIONS FOR ASPHALTIC CONCRETE FOUNDATIONS. REFERENCE BSI DRAWING A640113.  
 TORQUE ASPHALT ANCHORS TO 5 FT-LBF (8 N-m).  
 TORQUE CABLES TO 120 FT-LBF (160 N-m).  
 ANCHORING COMPOUND MUST MEET BSI SPECIFICATIONS.  
 USE ALL ANCHORING POINTS INTO ASPHALTIC CONCRETE FOUNDATION.  
 BACKSTOP AND CABLE ANCHOR SHOWN FOR REFERENCE.  
 REFERENCE BSI-1798040-00 FOR TAU-M TL-3 SYSTEM INSTALLATION.

ITEM	PART NO.	Description	QTY.	UOM
1	BSI-1806012-00	CROSSMEMBER, GALVANIZED	1	EA
2	BSI-1806016-00	BACKSTOP BRACE, RIGHT HAND, GALVANIZED	1	EA
3	BSI-1806018-00	BACKSTOP BRACE, LEFT HAND, GALVANIZED	1	EA
4	BSI-1806006-00	REAR PLATE, GALV	1	EA
5	BSI-1806008-00	TIE CHANNEL, GALV	1	EA
6	BSI-1806038-KT	ASPHALT HW KIT, TAU-M	1	EA
7	BSI-1798019-00	SLIDING PANEL, GALVANIZED, TAU-M	4	EA
8	BSI-1803016-00	SLIDER SHIM, GEOMET, TAU-M	8	EA

\*NOT SHOWN

LINDSAY TRANSPORTATION SOLUTIONS 10000 W. 10TH AVENUE, SUITE 100 DENVER, CO 80202 TEL: 303.501.1000 FAX: 303.501.1001 WWW.LINDSAYTRANSPORTATIONSOLUTIONS.COM		
<b>LINDSAY</b> TRANSPORTATION SOLUTIONS ASPHALT ANCHOR KIT		
UNLESS OTHERWISE SPECIFIED: DIMENSIONS ARE IN INCHES. DIMENSIONS IN PARENTHESES ARE IN MILLIMETERS. FINISHES ARE: P-1 STAINLESS STEEL P-2 POLISHED STAINLESS STEEL P-3 POLISHED 316 STAINLESS STEEL P-4 POLISHED 304 STAINLESS STEEL P-5 POLISHED 304 STAINLESS STEEL P-6 POLISHED 304 STAINLESS STEEL P-7 POLISHED 304 STAINLESS STEEL P-8 POLISHED 304 STAINLESS STEEL P-9 POLISHED 304 STAINLESS STEEL P-10 POLISHED 304 STAINLESS STEEL P-11 POLISHED 304 STAINLESS STEEL P-12 POLISHED 304 STAINLESS STEEL P-13 POLISHED 304 STAINLESS STEEL P-14 POLISHED 304 STAINLESS STEEL P-15 POLISHED 304 STAINLESS STEEL P-16 POLISHED 304 STAINLESS STEEL P-17 POLISHED 304 STAINLESS STEEL P-18 POLISHED 304 STAINLESS STEEL P-19 POLISHED 304 STAINLESS STEEL P-20 POLISHED 304 STAINLESS STEEL P-21 POLISHED 304 STAINLESS STEEL P-22 POLISHED 304 STAINLESS STEEL P-23 POLISHED 304 STAINLESS STEEL P-24 POLISHED 304 STAINLESS STEEL P-25 POLISHED 304 STAINLESS STEEL P-26 POLISHED 304 STAINLESS STEEL P-27 POLISHED 304 STAINLESS STEEL P-28 POLISHED 304 STAINLESS STEEL P-29 POLISHED 304 STAINLESS STEEL P-30 POLISHED 304 STAINLESS STEEL P-31 POLISHED 304 STAINLESS STEEL P-32 POLISHED 304 STAINLESS STEEL P-33 POLISHED 304 STAINLESS STEEL P-34 POLISHED 304 STAINLESS STEEL P-35 POLISHED 304 STAINLESS STEEL P-36 POLISHED 304 STAINLESS STEEL P-37 POLISHED 304 STAINLESS STEEL P-38 POLISHED 304 STAINLESS STEEL P-39 POLISHED 304 STAINLESS STEEL P-40 POLISHED 304 STAINLESS STEEL P-41 POLISHED 304 STAINLESS STEEL P-42 POLISHED 304 STAINLESS STEEL P-43 POLISHED 304 STAINLESS STEEL P-44 POLISHED 304 STAINLESS STEEL P-45 POLISHED 304 STAINLESS STEEL P-46 POLISHED 304 STAINLESS STEEL P-47 POLISHED 304 STAINLESS STEEL P-48 POLISHED 304 STAINLESS STEEL P-49 POLISHED 304 STAINLESS STEEL P-50 POLISHED 304 STAINLESS STEEL P-51 POLISHED 304 STAINLESS STEEL P-52 POLISHED 304 STAINLESS STEEL P-53 POLISHED 304 STAINLESS STEEL P-54 POLISHED 304 STAINLESS STEEL P-55 POLISHED 304 STAINLESS STEEL P-56 POLISHED 304 STAINLESS STEEL P-57 POLISHED 304 STAINLESS STEEL P-58 POLISHED 304 STAINLESS STEEL P-59 POLISHED 304 STAINLESS STEEL P-60 POLISHED 304 STAINLESS STEEL P-61 POLISHED 304 STAINLESS STEEL P-62 POLISHED 304 STAINLESS STEEL P-63 POLISHED 304 STAINLESS STEEL P-64 POLISHED 304 STAINLESS STEEL P-65 POLISHED 304 STAINLESS STEEL P-66 POLISHED 304 STAINLESS STEEL P-67 POLISHED 304 STAINLESS STEEL P-68 POLISHED 304 STAINLESS STEEL P-69 POLISHED 304 STAINLESS STEEL P-70 POLISHED 304 STAINLESS STEEL P-71 POLISHED 304 STAINLESS STEEL P-72 POLISHED 304 STAINLESS STEEL P-73 POLISHED 304 STAINLESS STEEL P-74 POLISHED 304 STAINLESS STEEL P-75 POLISHED 304 STAINLESS STEEL P-76 POLISHED 304 STAINLESS STEEL P-77 POLISHED 304 STAINLESS STEEL P-78 POLISHED 304 STAINLESS STEEL P-79 POLISHED 304 STAINLESS STEEL P-80 POLISHED 304 STAINLESS STEEL P-81 POLISHED 304 STAINLESS STEEL P-82 POLISHED 304 STAINLESS STEEL P-83 POLISHED 304 STAINLESS STEEL P-84 POLISHED 304 STAINLESS STEEL P-85 POLISHED 304 STAINLESS STEEL P-86 POLISHED 304 STAINLESS STEEL P-87 POLISHED 304 STAINLESS STEEL P-88 POLISHED 304 STAINLESS STEEL P-89 POLISHED 304 STAINLESS STEEL P-90 POLISHED 304 STAINLESS STEEL P-91 POLISHED 304 STAINLESS STEEL P-92 POLISHED 304 STAINLESS STEEL P-93 POLISHED 304 STAINLESS STEEL P-94 POLISHED 304 STAINLESS STEEL P-95 POLISHED 304 STAINLESS STEEL P-96 POLISHED 304 STAINLESS STEEL P-97 POLISHED 304 STAINLESS STEEL P-98 POLISHED 304 STAINLESS STEEL P-99 POLISHED 304 STAINLESS STEEL P-100 POLISHED 304 STAINLESS STEEL	TITLE DATE DRAWN BY CHECKED BY APPROVED BY DATE	
APPROVALS DATE: 6/5/2018 BY: G.A.D. DATE: 6/5/2018	REV. NO. SIZE DATE ECN#	REV. NO. SIZE DATE ECN#
DO NOT SCALE DRAWING	TOTAL: 1:30	SHEET: 1 OF 1

# Drawings UNIVERSAL TAU-M PARALLEL TRANSITION TO MEDIAN BARRIER BI-DIRECTIONAL TRAFFIC FLOW

Last Saved by: jason.lindsay@lindsayts.com Thursday, August 30, 2018 10:06:21 AM

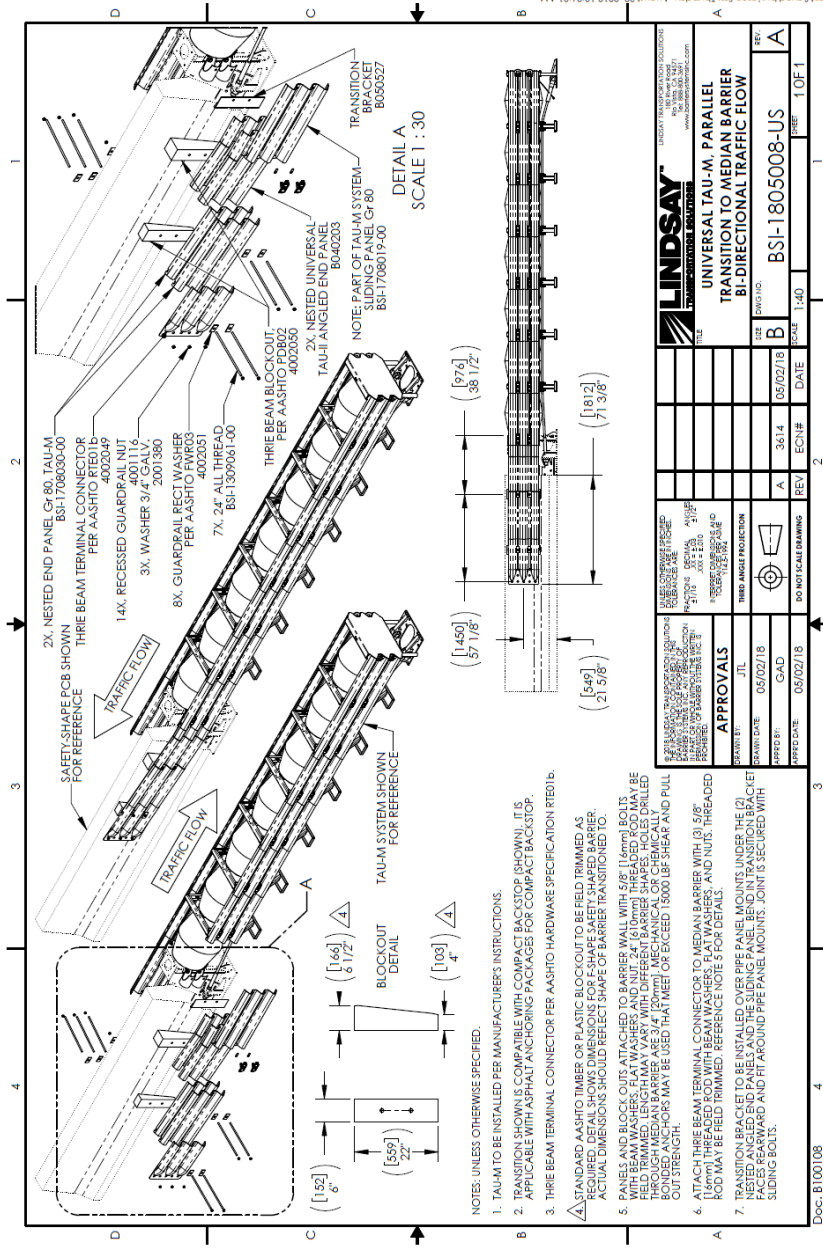

DETAIL A  
SCALE 1 : 30

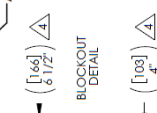
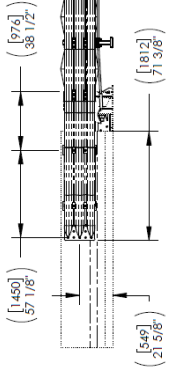

- NOTES: UNLESS OTHERWISE SPECIFIED.
1. TAU-M TO BE INSTALLED PER MANUFACTURER'S INSTRUCTIONS.
  2. TRANSITION SHOWN IS COMPATIBLE WITH COMPACT BACKSTOP. SHOWN. IT IS APPLICABLE WITH ASPHALT AND CONCRETE PACKAGES FOR COMPACT BACKSTOP.
  3. THREE BEAM TERMINAL CONNECTOR PER AASHTO HARDWARE SPECIFICATION RTED116.
  4. STANDARD AASHTO TIMBER OR PLASTIC BLOCKOUT TO BE FIELD TERMINATED AS REQUIRED. DETAIL SHOWS DIMENSIONS FOR E-SHAPE SAFETY SHAPED BARRIER. ACTUAL DIMENSIONS SHOULD REFLECT SHAPE OF BARRIER TRANSITIONED TO.
  5. PANELS AND BLOCK OUTS ATTACHED TO BARRIER WALL WITH 5/8" (16mm) BOLTS WITH BEAM WASHERS, FLAT WASHERS AND NUTS. 24" (610mm) THREADED ROD MAY BE USED TO ATTACH THROUGH MEDIAN BARRIER. USE 3/4" (20mm) MECHANICAL OR CHEMICAL WELLED BONDED ANCHORS MAY BE USED THAT MEET OR EXCEED 15000 LB. SHEAR AND FULL TENSILE STRENGTH.
  6. ATTACH THREE BEAM TERMINAL CONNECTOR TO MEDIAN BARRIER WITH (3) 5/8" THREADED ROD W/ BEAM WASHERS AND NUTS. REFER TO DETAIL A FOR DETAILS.
  7. TRANSITION SHALL BE INSTALLED AS SHOWN. THE PANELS AND NUTS UNDER THE (2) NESTED ANGLE END PANELS AND THE CURB END PANELS AND NUTS UNDER THE (2) CURB END PANELS SHALL BE INSTALLED TO THE CURB SIDE OF THE TRANSITION. THE CURB ENDS SHALL BE INSTALLED TO THE CURB SIDE OF THE TRANSITION. THE CURB ENDS SHALL BE INSTALLED TO THE CURB SIDE OF THE TRANSITION. THE CURB ENDS SHALL BE INSTALLED TO THE CURB SIDE OF THE TRANSITION. THE CURB ENDS SHALL BE INSTALLED TO THE CURB SIDE OF THE TRANSITION.

		TITLE <b>UNIVERSAL TAU-M, PARALLEL TRANSITION TO MEDIAN BARRIER BI-DIRECTIONAL TRAFFIC FLOW</b>	
DRAWN BY: JTL	CHECKED BY: GAD	DATE: 05/02/18	SCALE: 1:40
APPROVALS JTL GAD	REV. NO. A	DATE 05/02/18	SCALE 1:40
PROJECT NO. BSI-1805008-US		SHEET NO. 1 OF 1	

Doc. B100108

# Drawings COMPACT BACKSTOP TO SAFETY PCB BI-DIRECTIONAL TRAFFIC FLOW

Least Squared by Joannette, Thursday, August 30, 2018 2:06:11 PM

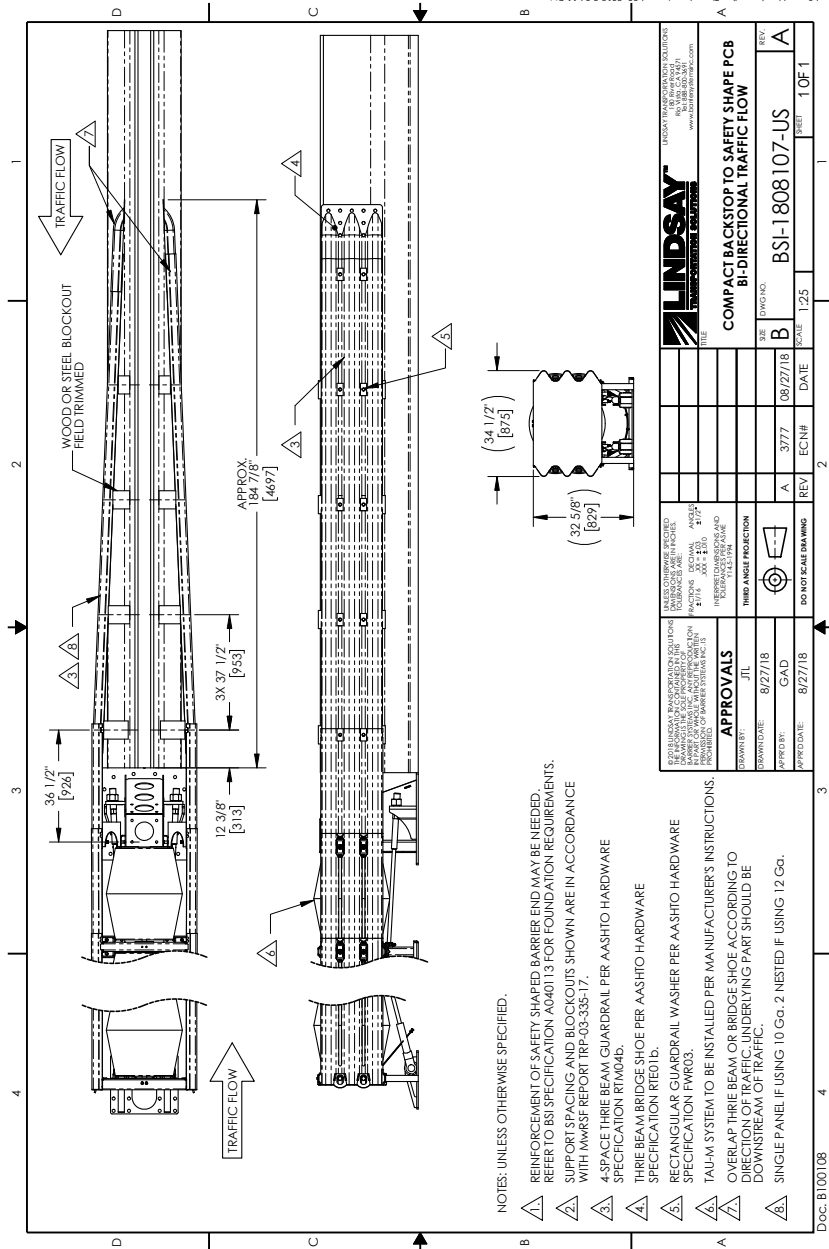

- NOTES: UNLESS OTHERWISE SPECIFIED.
- 1. REINFORCEMENT OF SAFETY SHAPED BARRIER END MAY BE NEEDED. REFER TO BSI SPECIFICATION AG401.13 FOR FOUNDATION REQUIREMENTS.
  - 2. SUPPORT SPACING AND BLOCKOUTS SHOWN ARE IN ACCORDANCE WITH MWRSF REPORT TRP-03-335-17.
  - 3. 4-SPACE THREE BEAM GUARDRAIL PER AASHTO HARDWARE SPECIFICATION RTM04B.
  - 4. THREE BEAM BRIDGE SHOE PER AASHTO HARDWARE SPECIFICATION RT01b.
  - 5. RECTANGULAR GUARDRAIL WASHER PER AASHTO HARDWARE SPECIFICATION FW003.
  - 6. TAU-M SYSTEM TO BE INSTALLED PER MANUFACTURER'S INSTRUCTIONS. OVERLAP THREE BEAM OR BRIDGE SHOE ACCORDING TO DIRECTION OF TRAFFIC. UNDERLYING PART SHOULD BE DOWNSTREAM OF TRAFFIC.
  - 7. SINGLE PANEL IF USING 10 Gg.2 NESTED IF USING 12 Gg.

COMPACT BACKSTOP TO SAFETY SHAPE PCB BI-DIRECTIONAL TRAFFIC FLOW	
REV. A	REV. B
DATE: 08/27/18	DATE: 08/27/18
ECN#: A.3777	ECN#: B.3777
PROJECT: 10F-1	PROJECT: 10F-1
APPROVALS:	
DESIGNED BY: JTL	APPROVED BY: GAD
DRAWN DATE: 8/27/18	APPROVED DATE: 8/27/18
DO NOT SCALE DRAWING	

Doc. B100108

# Drawings COMPACT BACKSTOP TO SAFETY PCB ONE SIDE BI-DIRECTIONAL TRAFFIC FLOW

Least Squared by Johnson: Thursday, August 30, 2018 2:04:11 PM

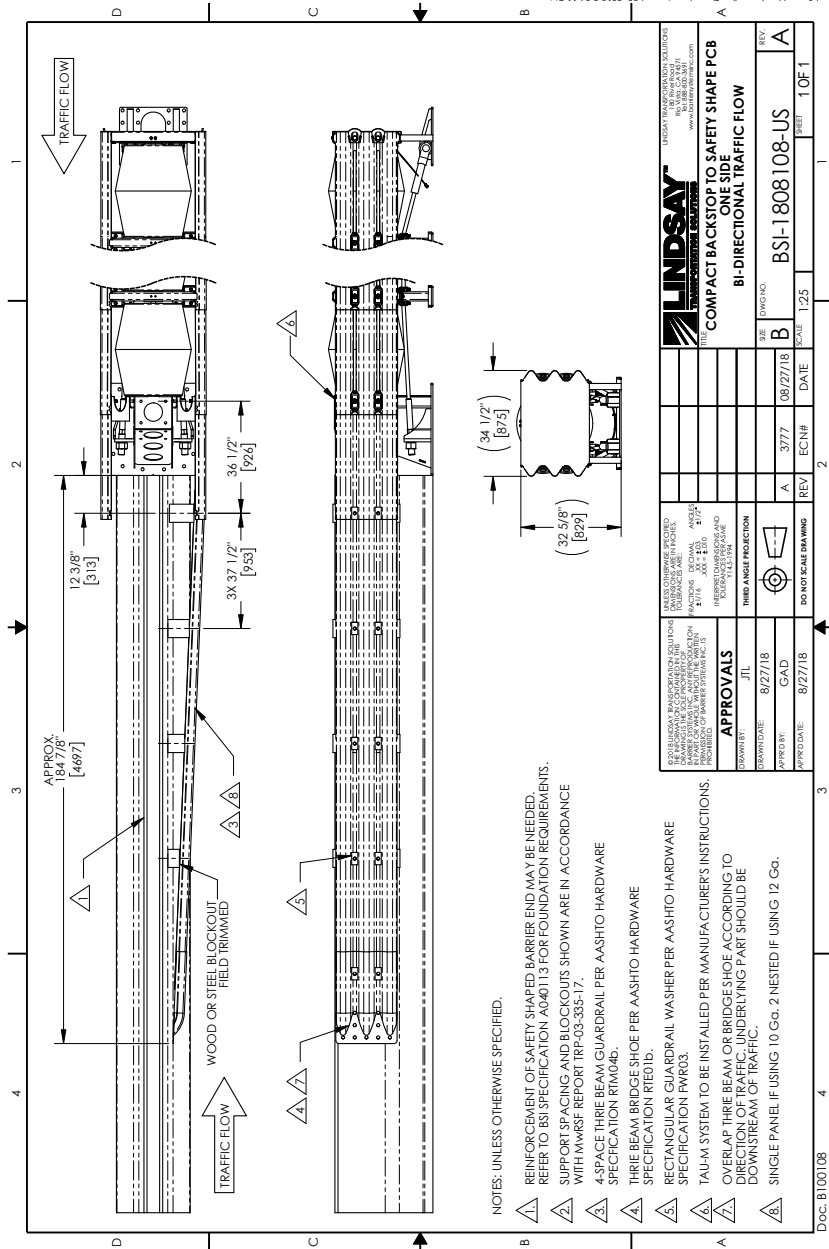

- NOTES: UNLESS OTHERWISE SPECIFIED.
- 1 REINFORCEMENT OF SAFETY SHAPED BARRIER END MAY BE NEEDED. REFER TO BSJ SPECIFICATION A040113 FOR FOUNDATION REQUIREMENTS.
  - 2 SUPPORT BRACINGS AND BLOCKOUTS SHOWN ARE IN ACCORDANCE WITH MHSR REPORT TR-05-353-17.
  - 3 4-SPACE THREE BEAM GUARDRAIL PER AASHTO HARDWARE SPECIFICATION R1M04b.
  - 4 THREE BEAM BRIDGE SHOE PER AASHTO HARDWARE SPECIFICATION R1E01b.
  - 5 RECTANGULAR GUARDRAIL WASHER PER AASHTO HARDWARE SPECIFICATION FWR03.
  - 6 TAU-M SYSTEM TO BE INSTALLED PER MANUFACTURER'S INSTRUCTIONS.
  - 7 OVERLAP THREE BEAM OR BRIDGE SHOE ACCORDING TO DIRECTION OF TRAFFIC. UNDERLYING PART SHOULD BE DOWNSTREAM OF TRAFFIC.
  - 8 SINGLE PANEL IF USING 10 Gg. 2 NESTED IF USING 12 Gg.

<p><b>LINDSAY</b> TRANSPORTATION SOLUTIONS</p>		<p>COMPACT BACKSTOP TO SAFETY SHAPE PCB ONE SIDE BI-DIRECTIONAL TRAFFIC FLOW</p>	
<p>UNLESS OTHERWISE SPECIFIED DIMENSIONS ARE TO FACE UNLESS INDICATED OTHERWISE</p>	<p>DATE: 08/27/18 DRAWN BY: JTL CHECKED BY: GAD</p>	<p>REV. DATE ECRN</p>	<p>REV. DATE ECRN</p>
<p>APPROVALS</p>	<p>APPROVED BY: GAD</p>	<p>REV. DATE ECRN</p>	<p>REV. DATE ECRN</p>
<p>DATE: 8/27/18</p>	<p>DATE: 08/27/18</p>	<p>REV. DATE ECRN</p>	<p>REV. DATE ECRN</p>
<p>PROJECT: 10F-1</p>	<p>PROJECT: 10F-1</p>	<p>REV. DATE ECRN</p>	<p>REV. DATE ECRN</p>
<p>PROJECT: 10F-1</p>	<p>PROJECT: 10F-1</p>	<p>REV. DATE ECRN</p>	<p>REV. DATE ECRN</p>

Doc. B100108



# Drawings COMPACT BACKSTOP TO SAFETY PCB OFFSET BI-DIRECTIONAL TRAFFIC FLOW

Least Saved by: jason.mt, Thursday, August 30, 2018 2:04:11 PM

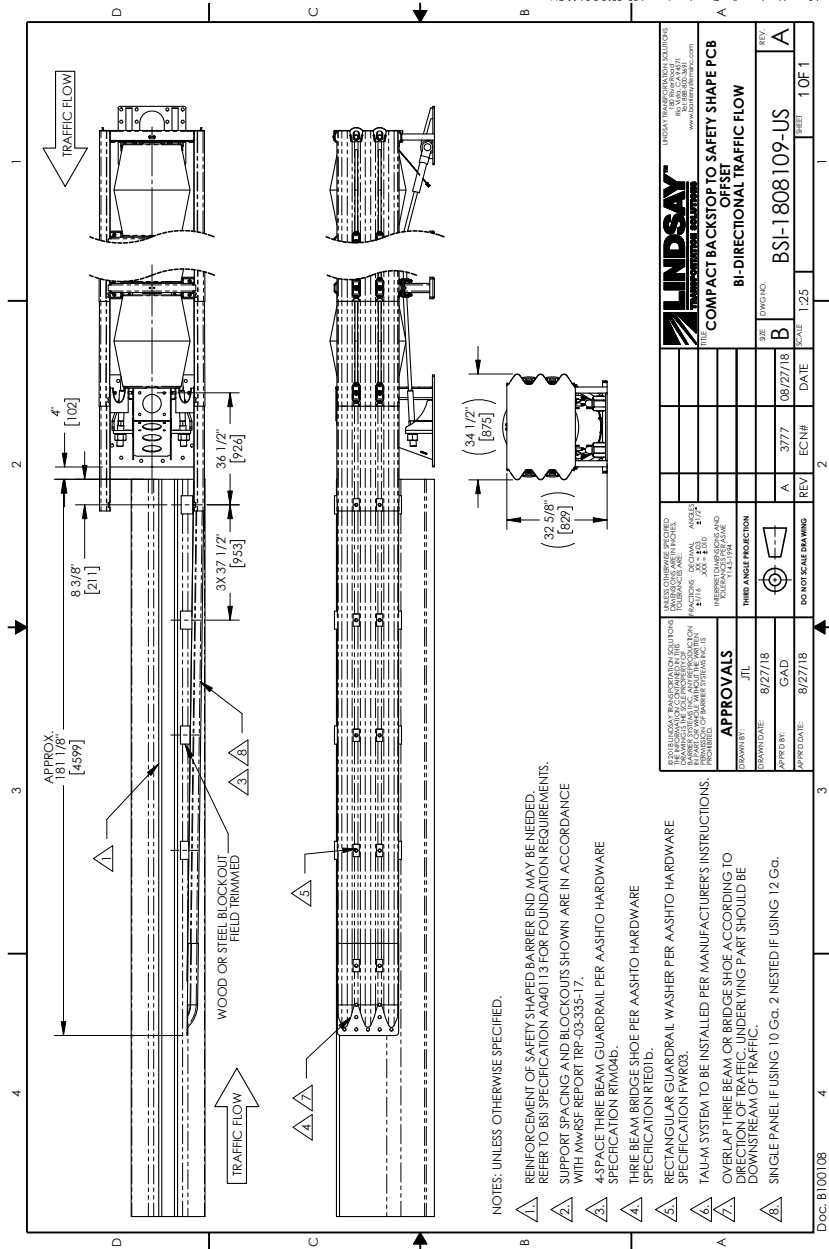

- NOTES: UNLESS OTHERWISE SPECIFIED.
- 1. REINFORCEMENT OF SAFETY SHAPED BARRIER END MAY BE NEEDED. REFER TO BSI SPECIFICATION A040113 FOR FOUNDATION REQUIREMENTS.
  - 2. SUPPORT SPA CINGS AND BLOCKOUTS SHOWN ARE IN ACCORDANCE WITH MWRSP REPORT TRF-03-333-17.
  - 3. 4-SPACE THREE BEAM GUARDRAIL PER AASHTO HARDWARE SPECIFICATION R1M04b.
  - 4. THREE BEAM BRIDGE SHOE PER AASHTO HARDWARE SPECIFICATION R1E01b.
  - 5. RECTANGULAR GUARDRAIL WASHER PER AASHTO HARDWARE SPECIFICATION FWR03.
  - 6. TAU-M SYSTEM TO BE INSTALLED PER MANUFACTURER'S INSTRUCTIONS. OVERLAP THREE BEAM OR BRIDGE SHOE ACCORDING TO DIRECTION OF TRAFFIC. UNDERLYING PART SHOULD BE DOWNSTREAM OF TRAFFIC.
  - 7. SINGLE PANEL IF USING 10 Gg. 2 NESTED IF USING 12 Gg.

		<b>COMPACT BACKSTOP TO SAFETY SHAPE PCB OFFSET BI-DIRECTIONAL TRAFFIC FLOW</b>	
APPROVALS DRAWN BY: JTL APPROVED: GAD DATE: 8/27/18	REV. A DATE: 08/27/18	REV. B DATE:	REV. A DATE:
PROJECT: 125		DRAWING NO: BSI-1808109-US	
SHEET: 1 OF 1		SCALE:	

Doc. B100108

# Drawings COMPACT BACKSTOP TO CONCRETE END SHOE

Least Saved by: jomant, Thursday, August 30, 2018 4:04:02 PM

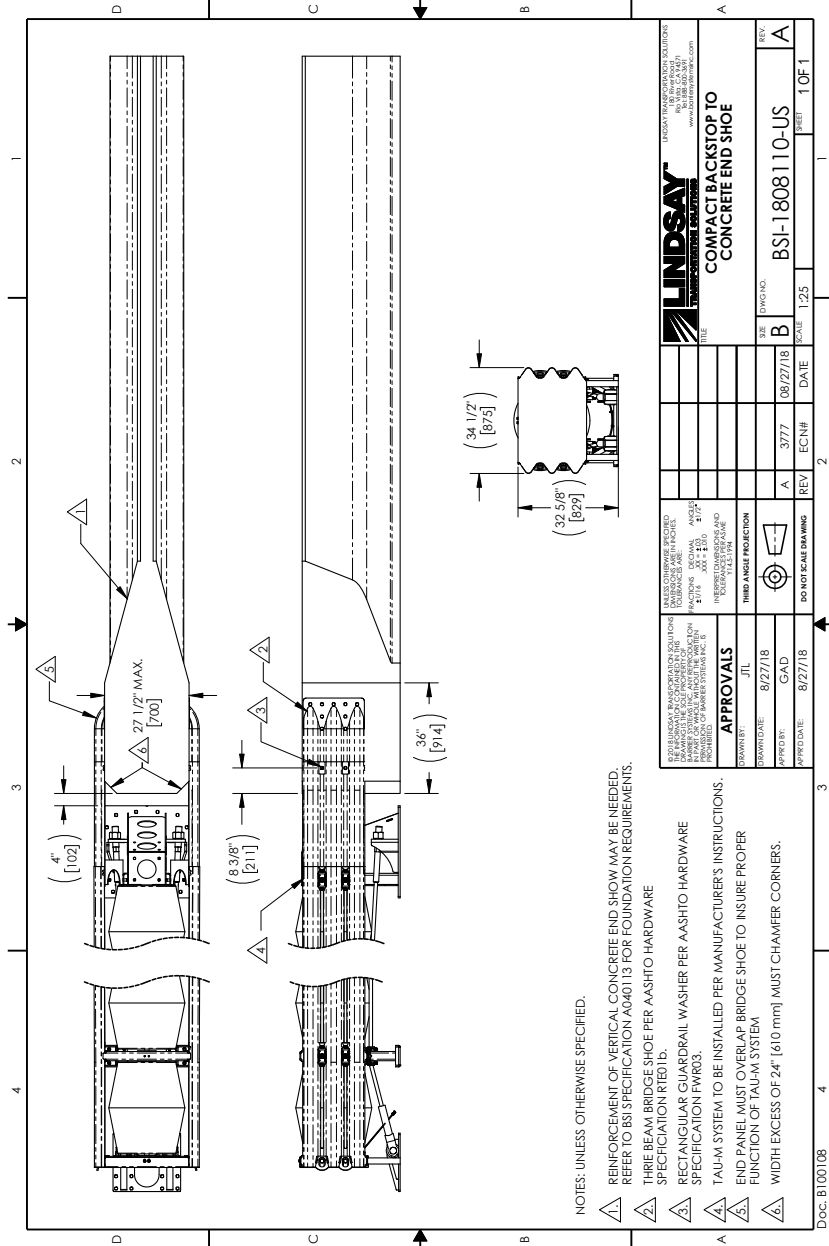

NOTES: UNLESS OTHERWISE SPECIFIED,

- 1 REINFORCEMENT OF VERTICAL CONCRETE END SHOE MAY BE NEEDED. REFER TO BS1 SPECIFICATION AG40115 FOR FOUNDATION REQUIREMENTS.
- 2 THREE BEAM BRIDGE SHOE PER AASHTO HARDWARE SPECIFICATION RT10.
- 3 RECTANGULAR GUARDRAIL WASHER PER AASHTO HARDWARE SPECIFICATION FW03.
- 4 TAU-M SYSTEM TO BE INSTALLED PER MANUFACTURER'S INSTRUCTIONS. END PANEL MUST OVERLAP BRIDGE SHOE TO INSURE PROPER FUNCTION OF TAU-M SYSTEM.
- 5 WIDTH EXCESS OF 24" (610 mm) MUST CHAMFER CORNERS.

<p>SPONSORING AGENCY SPECIFIED DRAWING TO BE PROVIDED TO CONTRACTOR BY DATE OF ISSUE. THIS DRAWING IS THE PROPERTY OF LINDSAY TRANSPORTATION SOLUTIONS AND IS NOT TO BE REPRODUCED OR COPIED IN ANY MANNER WITHOUT THE WRITTEN CONSENT OF LINDSAY TRANSPORTATION SOLUTIONS.</p>		<p>LINDSAY TRANSPORTATION SOLUTIONS 1801 BROADWAY, SUITE 200 DENVER, CO 80202 TEL: 303.733.1100 WWW.LINDSAYTRANSPORT.COM</p>	
<p>APPROVALS</p> <p>DRAWN BY: JTL DATE: 8/27/18</p> <p>APPROVED BY: GAD DATE: 8/27/18</p>		<p>DO NOT SCALE DRAWING</p>	
<p>REV. A. 3/77. 03/27/18</p>		<p>REV. B. 03/27/18</p>	
<p>REV. A. 10/1</p>		<p>REV. A. 10/1</p>	
<p>PROJECT: 108110-US</p>		<p>SCALE: 1:25</p>	

# Drawings COMPACT BACKSTOP TO THREE BEAM GUARDRAIL BI-DIRECTIONAL TRAFFIC FLOW

Least Scanned By: jason.mt, Thursday, August 30, 2018 2:11:11 PM

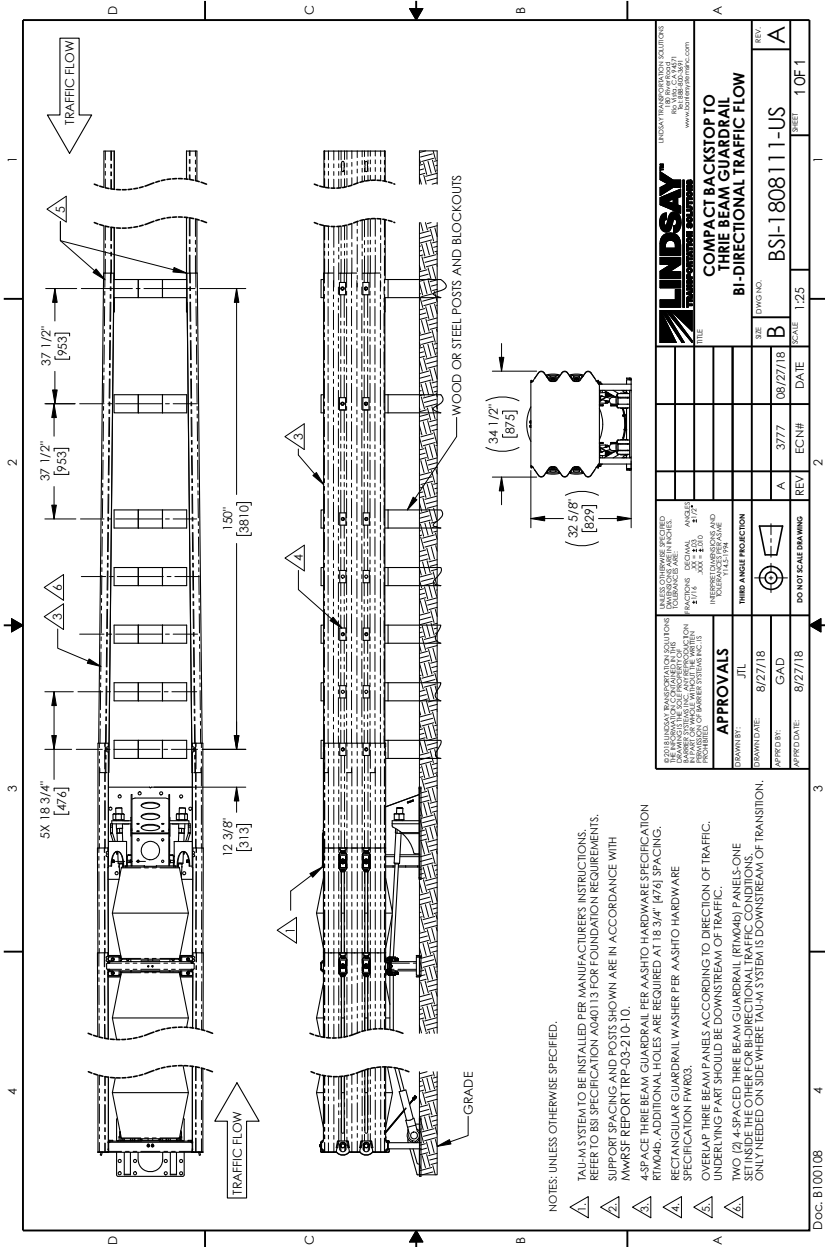

- ▲ UNLESS OTHERWISE SPECIFIED, REFER TO BS SPECIFICATION A60113 FOR FOUNDATION REQUIREMENTS.
- ▲ SUPPORT SPACING AND POSTS SHOWN ARE IN ACCORDANCE WITH MMSRF REPORT TRP-03-21(1)-10.
- ▲ 4-SPACE THREE BEAM GUARDRAIL PER AASHTO HARDWARE SPECIFICATION R104d. ADDITIONAL HOLES ARE REQUIRED AT 18 3/4\"/>
- ▲ RECTANGULAR GUARDRAIL WASHER PER AASHTO HARDWARE SPECIFICATION FW03.
- ▲ OVERLAP THREE BEAM PANELS ACCORDING TO DIRECTION OF TRAFFIC. UNDERLAP PANEL SHOULD BE DOWNSTREAM OF TRAFFIC.
- ▲ TWO (2) 4-SPACED THREE BEAM GUARDRAIL (R104d) PANELS-ONE DOWNSTREAM AND ONE UPSTREAM OF TRANSITION.
- ▲ ONLY NEEDED ON SIDE WHERE TAU-M SYSTEM IS DOWNSTREAM OF TRANSITION.

NOTES: UNLESS OTHERWISE SPECIFIED.

LINDSAY TRANSPORTATION SOLUTIONS TRANSPORTATION SOLUTIONS 901 BRIDGE BLVD. SUITE 100 WILSONVILLE, OR 97158 WWW.LINDSAYTRANSP.COM	
UNLESS OTHERWISE SPECIFIED, REFER TO BS SPECIFICATION A60113 FOR FOUNDATION REQUIREMENTS. DRAWING IS THE PROPERTY OF LINDSAY TRANSPORTATION SOLUTIONS. NO PART OF THIS DRAWING IS TO BE REPRODUCED OR TRANSMITTED IN ANY FORM OR BY ANY MEANS, WITHOUT PERMISSION IN WRITING FROM LINDSAY TRANSPORTATION SOLUTIONS.	
APPROVALS DRAWN BY: JTL CHECKED BY: GAD DATE: 8/27/18	THIRD ANGLE PROJECTION TOLERANCES UNLESS OTHERWISE SPECIFIED ARE: FRACTIONS .005" MIN. DECIMALS .015" MIN. HOLE DIMENSIONS .015" MIN.
REV. A. 3/7/17 REV. B. 03/27/18	REV. A. 10/11/17 REV. B. 03/27/18
PROJECT: BSI-180811-US DRAWING NO. BSI-180811-10	SHEET: 1 OF 1 DATE: 1/25

Doc. B100108

# Drawings COMPACT BACKSTOP TO W-BEAM GUARDRAIL BI-DIRECTIONAL TRAFFIC FLOW

Last Saved By: jasonlmt, Thursday, August 30, 2018 2:11:11 PM

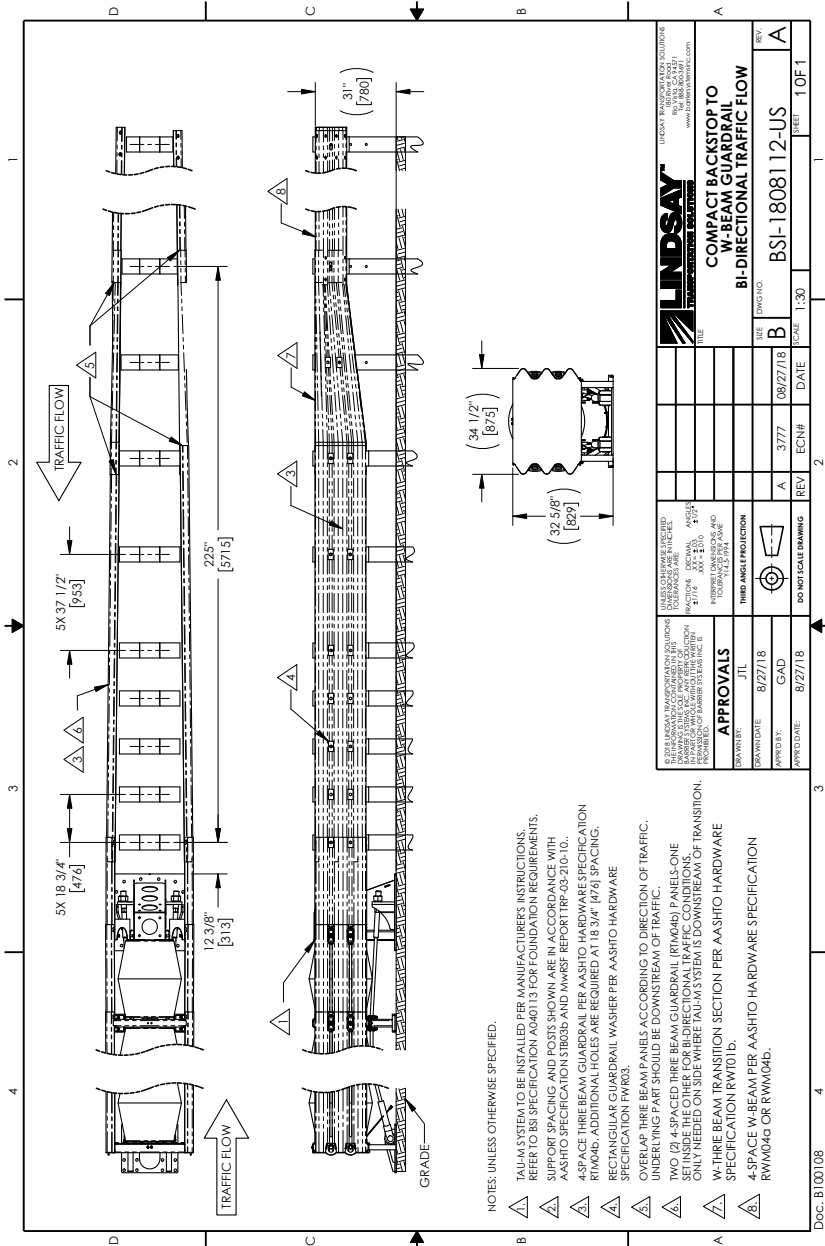

NOTES UNLESS OTHERWISE SPECIFIED:

- ▲ TAU-M SYSTEM TO BE INSTALLED PER MANUFACTURER'S INSTRUCTIONS. REFER TO BSI SPECIFICATION AG40113 FOR FOUNDATION REQUIREMENTS. SUPPORT SPACING AND POSTS SHOWN ARE IN ACCORDANCE WITH AASHTO SPECIFICATION STB30B AND MHWSE REPORT RP-03-210-10.
- ▲ 4-SPACE THREE BEAM GUARDRAIL PER AASHTO HARDWARE SPECIFICATION RW404B. ADDITIONAL HOLES ARE REQUIRED AT 18 3/4" [476] SPACING. RECTANGULAR GUARDRAIL WASHER PER AASHTO HARDWARE SPECIFICATION FW63.
- ▲ OVERLAP THREE BEAM PANELS ACCORDING TO DIRECTION OF TRAFFIC. UNDERLAP THREE BEAM PANELS SHOULD BE DOWNSTREAM OF TRAFFIC.
- ▲ TWO (2) 4-SPACE THREE BEAM GUARDRAIL (RW404) PANELS, ONE ONLY NEEDED ON SIDE WHERE TAU-M SYSTEM IS DOWNSTREAM OF TRANSITION.
- ▲ W-THE BEAM TRANSITION SECTION PER AASHTO HARDWARE SPECIFICATION RW101 D.
- ▲ 4-SPACE W-BEAM PER AASHTO HARDWARE SPECIFICATION RW1040G OR RW1040B.

		LINDSAY TRANSPORTATION SOLUTIONS LINDSAY TRANSPORTATION SOLUTIONS 1000 W. 100th St., Suite 100 Omaha, NE 68164 Phone: (402) 426-1111 Fax: (402) 426-1112 www.lindsaytrans.com	
TITLE <b>COMPACT BACKSTOP TO W-BEAM GUARDRAIL BI-DIRECTIONAL TRAFFIC FLOW</b>		SET B	SHEET NO. BSI-1808112-US
DRAWN BY JTL	CHECKED BY GAD	DATE 08/27/18	SCALE 1:30
APPROVALS JTL GAD	ECN# 3777	REV A	DATE 08/27/18
DO NOT SCALE DRAWING		REV A	DATE 08/27/18

Doc: B100108

# Drawings COMPACT BACKSTOP TO OFFSET PCB WITH END SHOE BI-DIRECTIONAL TRAFFIC FLOW

Last Saved by: jomarrn, Friday, August 31, 2018 8:01:10 AM

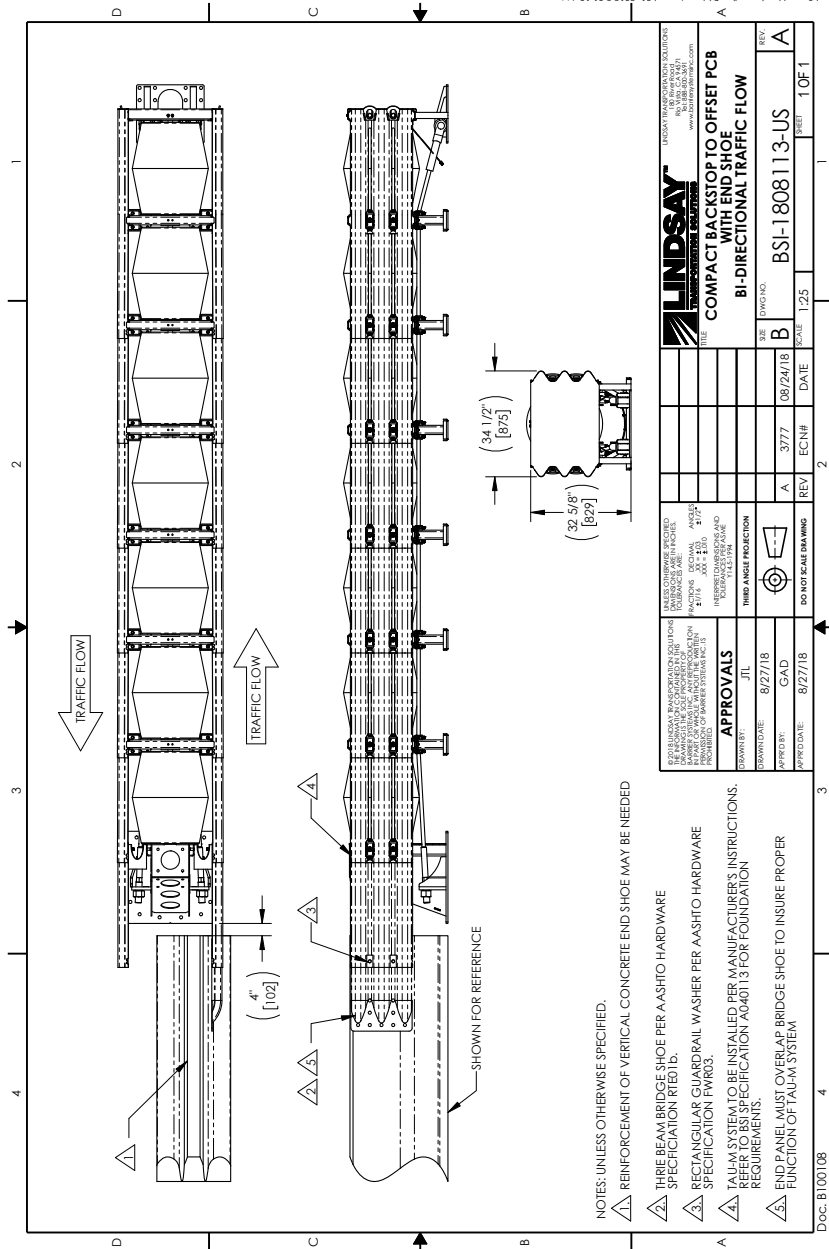

- NOTES: UNLESS OTHERWISE SPECIFIED,  
 ▲ REINFORCEMENT OF VERTICAL CONCRETE END SHOE MAY BE NEEDED
- ▲ TYPIC BEAM BRIDGE SHOE PER AASHTO HARDWARE SPECIFICATION RT101.10.
  - ▲ RECTANGULAR GUARDRAIL WASHER PER AASHTO HARDWARE SPECIFICATION FW803.
  - ▲ TAU-M SYSTEM TO BE INSTALLED PER MANUFACTURER'S INSTRUCTIONS. REFER TO BSI SPECIFICATION A040113 FOR FOUNDATION REQUIREMENTS.
  - ▲ END PANEL MUST OVERLAP BRIDGE SHOE TO INSURE PROPER FUNCTION OF TAU-M SYSTEM

		<b>COMPACT BACKSTOP TO OFFSET PCB WITH END SHOE BI-DIRECTIONAL TRAFFIC FLOW</b>	
SPECIFICATIONS TRANSPORTATION SOLUTIONS DRAWINGS ARE THE PROPERTY OF LINDSAY TRANSPORTATION SOLUTIONS. NO PART OF THIS DRAWING IS TO BE REPRODUCED OR TRANSMITTED IN ANY FORM OR BY ANY MEANS, ELECTRONIC OR MECHANICAL, INCLUDING PHOTOCOPYING, RECORDING, OR BY ANY INFORMATION STORAGE AND RETRIEVAL SYSTEM, WITHOUT THE WRITTEN PERMISSION OF LINDSAY TRANSPORTATION SOLUTIONS.	LINDSAY TRANSPORTATION SOLUTIONS 801 BIRCHWOOD BLVD SUITE 100 WILSONVILLE, OR 97158 WWW.LINDSAYTRANSPORTATIONSOLUTIONS.COM	DATE: 08/24/18 DRAWN BY: CAD CHECKED BY: JTL PROJECT NO: BS1-1808113-US	SHEET: 1 OF 1
APPROVALS DRAWN BY: JTL APPROVED BY: CAD SPECIFIED DATE: 8/27/18	REV: A REV: B REV: C	DATE: 08/24/18 DATE: 08/24/18 DATE: 08/24/18	REV: A REV: B REV: C
DO NOT SCALE DRAWING		ECNR: 2	SCALE: 1"=10'-1"

Doc. B100108

# Drawings COMPACT BACKSTOP UNIDIRECTIONAL TRAFFIC FLOW

Least Saved by: jcozminr, Thursday, August 30, 2018 4:04:02 PM

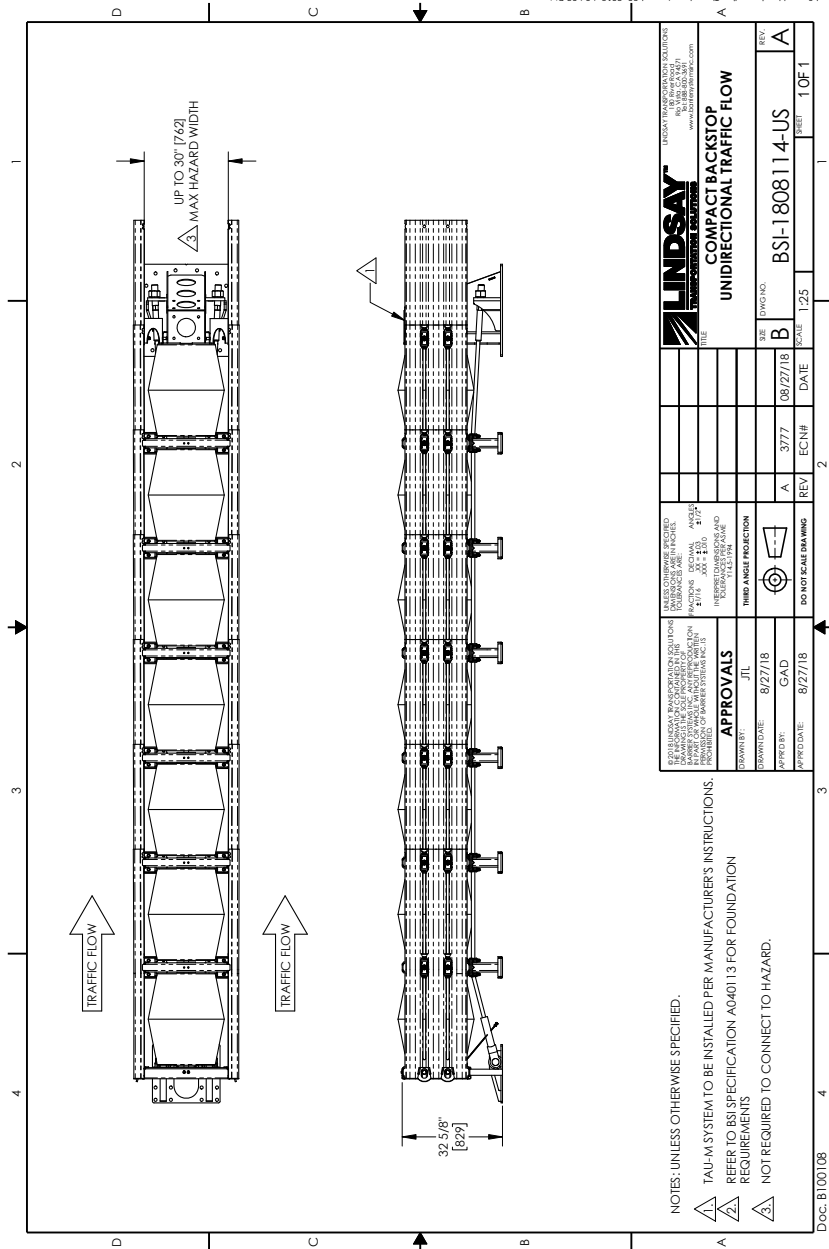

		LINDSAY TRANSPORTATION SOLUTIONS 801 BIRCHWOOD BLVD SUITE 100 WILSONVILLE, OR 97158 www.lindsaytrps.com	
UNLESS OTHERWISE SPECIFIED DIMENSIONS ARE IN INCHES DIMENSIONS IN PARENTHESES ARE IN MILLIMETERS FINISHES ARE AS SHOWN UNLESS OTHERWISE SPECIFIED ALL DIMENSIONS ARE TO FACE UNLESS OTHERWISE SPECIFIED		TITLE <b>COMPACT BACKSTOP UNIDIRECTIONAL TRAFFIC FLOW</b>	
DRAWN BY: JTL	DATE: 8/27/18	SIZE: DWG/NO. B	REV. A
APPROVED: GAD	DATE: 08/27/18	PROJECT: 1:25	REV. A
SPECIFICATION: 8/27/18	ECR#: A 3777	DATE: 08/27/18	PROJECT: 1 OF 1
APPROVED: 8/27/18	REV: 2	DATE: 08/27/18	PROJECT: 1 OF 1

NOTES: UNLESS OTHERWISE SPECIFIED.

▲ TAU-M SYSTEM TO BE INSTALLED PER MANUFACTURER'S INSTRUCTIONS. REFER TO BSI SPECIFICATION AG40113 FOR FOUNDATION REQUIREMENTS

▲ NOT REQUIRED TO CONNECT TO HAZARD.

Doc. B100108

## Long-Term Storage

Store materials under cover in dry, well-ventilated conditions, away from doorways open to the environment.

Supplied epoxy has a storage and shelf life of 28 months. Store epoxy in dry and cool environment.

Provide adequate ventilation between stacked pieces. Elevate and separate articles stacked outdoors with spacers (poplar, ash, spruce).

Incline parts to allow for maximum drainage.

Avoid stacking material directly on soil or decaying vegetation.

For crated items, remove the lids to provide better ventilation and drying of the galvanized parts. Customers will need to remove kits packed in cardboard boxes from the crates and store them inside.



Lindsay Transportation Solutions

180 River Road • Rio Vista, CA 94571 • +1 707.374.6800 U.S. Toll Free: 888.800.3691 • [www.lindsaytransportationsolutions.com](http://www.lindsaytransportationsolutions.com)

Installation manual for the TAU-M system is subject to change without notice to reflect improvements and upgrades.

Please contact Lindsay Transportation Solutions to confirm that you are using the most current installation manual and instructions.

Additional information is available from Lindsay Transportation Solutions. © Lindsay Transportation Solutions