

DRAWING INDEX

| SHEET | DESCRIPTION |
|----------|---|
| 1 of 11 | Universal TAU-M General Notes - Permanent |
| 2 of 11 | Universal TAU-M System Lengths |
| 3 of 11 | Universal TAU-M Foundation, Concrete Pad |
| 4 of 11 | Universal TAU-M Foundation Specifications |
| 5 of 11 | Universal TAU-M Test Level 2 System Layout |
| 6 of 11 | Universal TAU-M Test Level 2 System Layout |
| 7 of 11 | Universal TAU-M Transition to W-Beam Guardrail |
| 8 of 11 | Universal TAU-M Bidirectional Transition |
| 9 of 11 | Universal TAU-M Transition to Concrete Barrier with End Shoe |
| 10 of 11 | Universal TAU-M Transition to Offset Concrete Barrier with End Shoe |
| 11 of 11 | Universal TAU-M Foundation Extension, Concrete |

UNIVERSAL TAU-M GENERAL NOTES - PERMANENT

1. THE ENERGY ABSORBING SYSTEM REPRESENTED ON THIS APPROVED PRODUCT LIST (APL) IS A PROPRIETARY DESIGN BY LINDSAY TRANSPORTATION SOLUTIONS (LTS) AND MARKED UNDER THE TRADE NAME UNIVERSAL TAU-M.
2. THE UNIVERSAL TAU-M IS A REDIRECTIVE, NON-GATING CRASH CUSHION DESIGNED TO SHIELD HAZARDS UP TO 30 INCHES IN WIDTH. THE BEGINNING LENGTH OF NEED SHALL BE AT THE POINT OF INTERSECTION BETWEEN THE FACE OF THE CRASH CUSHION AND THE TRANSVERSE CENTERLINE OF THE FIRST MID-SUPPORT.
3. THE UNIVERSAL TAU-M HAS BEEN EVALUATED TO MASH CRASH TESTING CRITERIA AND IS SUITABLE FOR TEST LEVEL 2 CRASH CUSHION APPLICATIONS.
4. THE UNIVERSAL TAU-M SHALL BE ASSEMBLED AND INSTALLED IN ACCORDANCE WITH THE MANUFACTURER'S DETAILED DRAWINGS, PROCEDURES, SPECIFICATIONS, PRODUCT MANUAL, OR INSTALLATION GUIDE. INFORMATION AND COPIES OF THE ABOVE MANUAL ARE AVAILABLE ON THE APPROVED PRODUCT LIST (APL).
5. THE UNIVERSAL TAU-M IS AVAILABLE IN 30" NOMINAL WIDTH.
6. THE UNIVERSAL TAU-M SHALL BE CONSTRUCTED PARALLEL TO THE APPROACH TRAVEL LANE AND ON CROSS SLOPES 1:10 OR FLATTER.
7. METALLIC COMPONENTS SHALL MEET THE GALVANIZING REQUIREMENTS FOR GUARDRAIL, SECTION 967 OF THE FDOT SPECIFICATIONS.
8. ONLY THE UNIVERSAL TAU-M TYPE B ENERGY ABSORBING CARTRIDGES SHALL BE USED AS SHOWN ON THE DRAWINGS.
9. SUPPLY ADEQUATE TRANSITION FROM THE UNIVERSAL TAU-M SYSTEM TO THE OBJECT BEING SHIELDED IN BI-DIRECTIONAL APPLICATIONS.
10. UNITS OF MEASURE ARE IN ENGLISH UNITS.

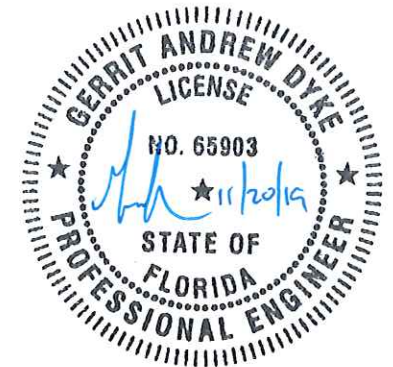

| | | | | | | | |
|---|-----------|--|-----|--|----------|--|----------------|
| <small>© 2019 LINDSAY TRANSPORTATION SOLUTIONS THE INFORMATION CONTAINED IN THIS DRAWING IS THE SOLE PROPERTY OF BARRIER SYSTEMS INC. ANY REPRODUCTION IN PART OR WHOLE WITHOUT THE WRITTEN PERMISSION OF BARRIER SYSTEMS INC. IS PROHIBITED.</small> | | <small>UNLESS OTHERWISE SPECIFIED DIMENSIONS ARE IN INCHES. TOLERANCES ARE: FRACTIONS ±1/16 DECIMAL .XX = ±.03 ANGLES ±1/2° .XXX = ±.010</small> | | | | <small>LINDSAY TRANSPORTATION SOLUTIONS 180 River Road Rio Vista, CA 94571 Tel: 888-800-3691 www.barriersystemsinc.com</small> | |
| APPROVALS | | <small>INTERPRET DIMENSIONS AND TOLERANCES PER ASME Y14.5-1994</small> | | UNIVERSAL TAU-M, TEST LEVEL 2, STATE OF FLORIDA DOT APL NO. 544-002-001 | | | |
| DRAWN BY: | NMB | THIRD ANGLE PROJECTION | C | AP 01398 | 09/23/19 | SIZE | DWG NO. |
| DRAWN DATE: | 3/18/2019 | | B | AP 01398 | 06/03/19 | B | BSI-1903002-AP |
| APPR'D BY: | GAD | | A | AP 01398 | 03/18/19 | | |
| APPR'D DATE: | 3/18/2019 | DO NOT SCALE DRAWING | REV | ECN# | DATE | SCALE | 1:1 |
| | | | | FDOT APL 544-002-001 | SHEET | 1 OF 11 | |

4

3

2

1

D

C

B

A

D

C

B

A

| TL2 | | | | | |
|-----------------------------|--------------|---------------|---------------|-------------------------|---------------------|
| DESIGN SPEED: 40 mph | | | | | |
| SYSTEM WIDTH | MODEL NUMBER | SYSTEM LENGTH | DESIGN LENGTH | GUARDRAIL DESIGN LENGTH | CONCRETE PAD LENGTH |
| 30" | 30TM070CC | 14'-3" | 10'-7" | 11'-7" | 15'-4" |

NOTES:

1. SYSTEM WIDTH IS NOMINAL, MEASURED AT THE BACKSTOP. ACTUAL WIDTH BETWEEN END PANELS IS 27 1/2". TO ACHIEVE 30" WIDTH BETWEEN END PANELS, SPREAD END PANELS TO FIT HAZARD PRIOR TO TORQUING SLIDER BOLTS AT END PANEL MOUNTS.
2. PAD LENGTH IS ROUNDED TO THE NEAREST INCH.

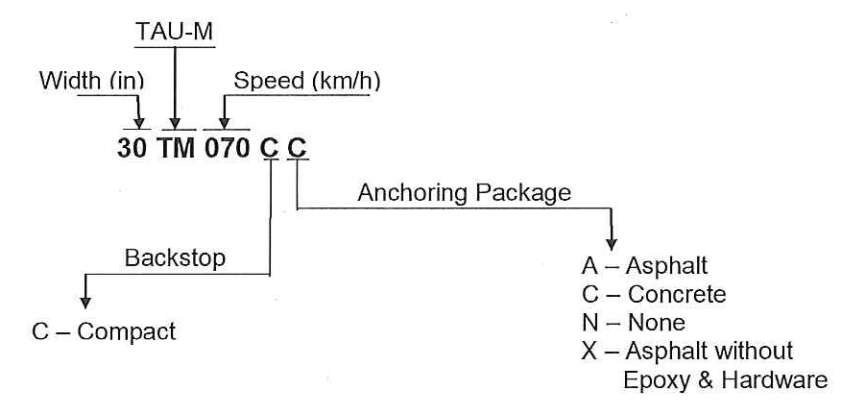
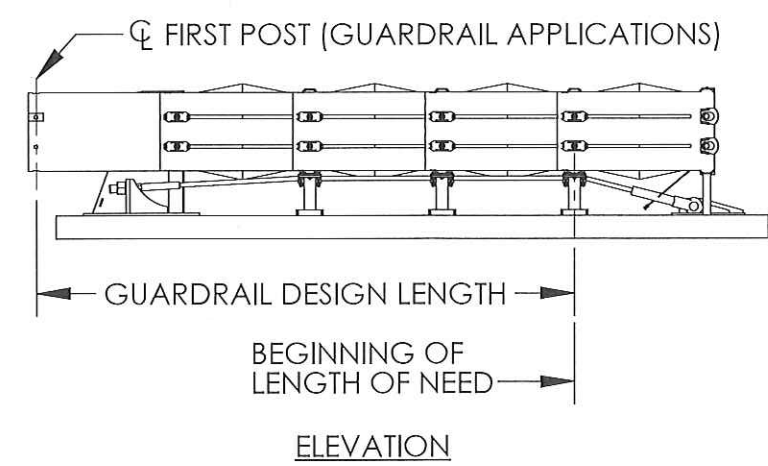
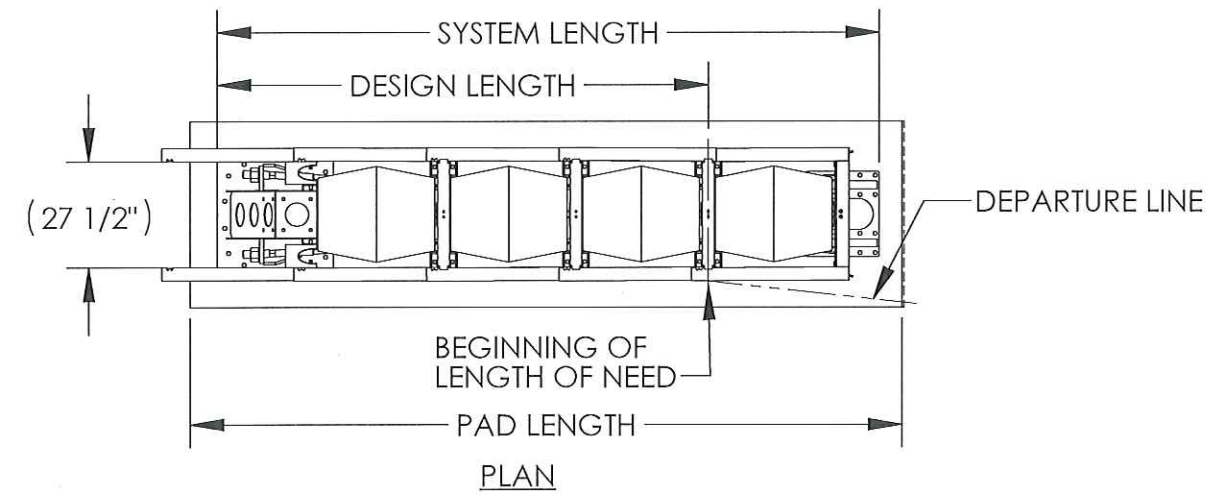

UNIVERSAL TAU-M SYSTEM LENGTHS



| | | |
|-------|----------------------|---------------|
| SIZE | DWG NO. | REV. |
| B | BSI-1903002-AP | C |
| SCALE | FDOT APL 544-002-001 | SHEET 2 OF 11 |
| 1:48 | | |

4

3

2

1

NOTES:

1. FOUNDATION MATERIAL, SPECIFICATIONS, AND ANCHORAGE MUST BE IN ACCORDANCE WITH FOUNDATION SPECIFICATIONS FOR A CONCRETE PAD. SEE SHEET 4.
2. NO REBAR IS NEEDED IN 8" THICK CONCRETE PAD.
3. IF FOUNDATION ABUTS A CONCRETE CURB, WALL, ABUTMENT, OR OTHER CONCRETE HAZARD, A 4" GAP BETWEEN COMPACT BACKSTOP AND BARRIER TO ALLOW SUFFICIENT ROOM FOR SOCKET USED TO TORQUE NUTS ON CABLE.
4. BACKSTOP ANCHORS REQUIRE 6" EMBEDMENT FOR 3/4" X 8 1/4" GALVANIZED ANCHOR.
5. TORQUE ANCHORS TO 120 FT-LBF.
6. FOR A 6" CONCRETE PAD, FOUNDATION REINFORCING (#5 REBAR) IS REQUIRED, SEE ASSEMBLY AND INSTALLATION MANUAL FOR ADDITIONAL DETAIL.

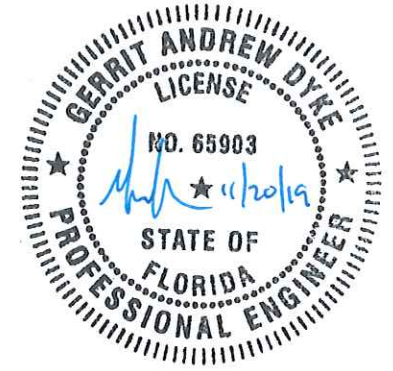
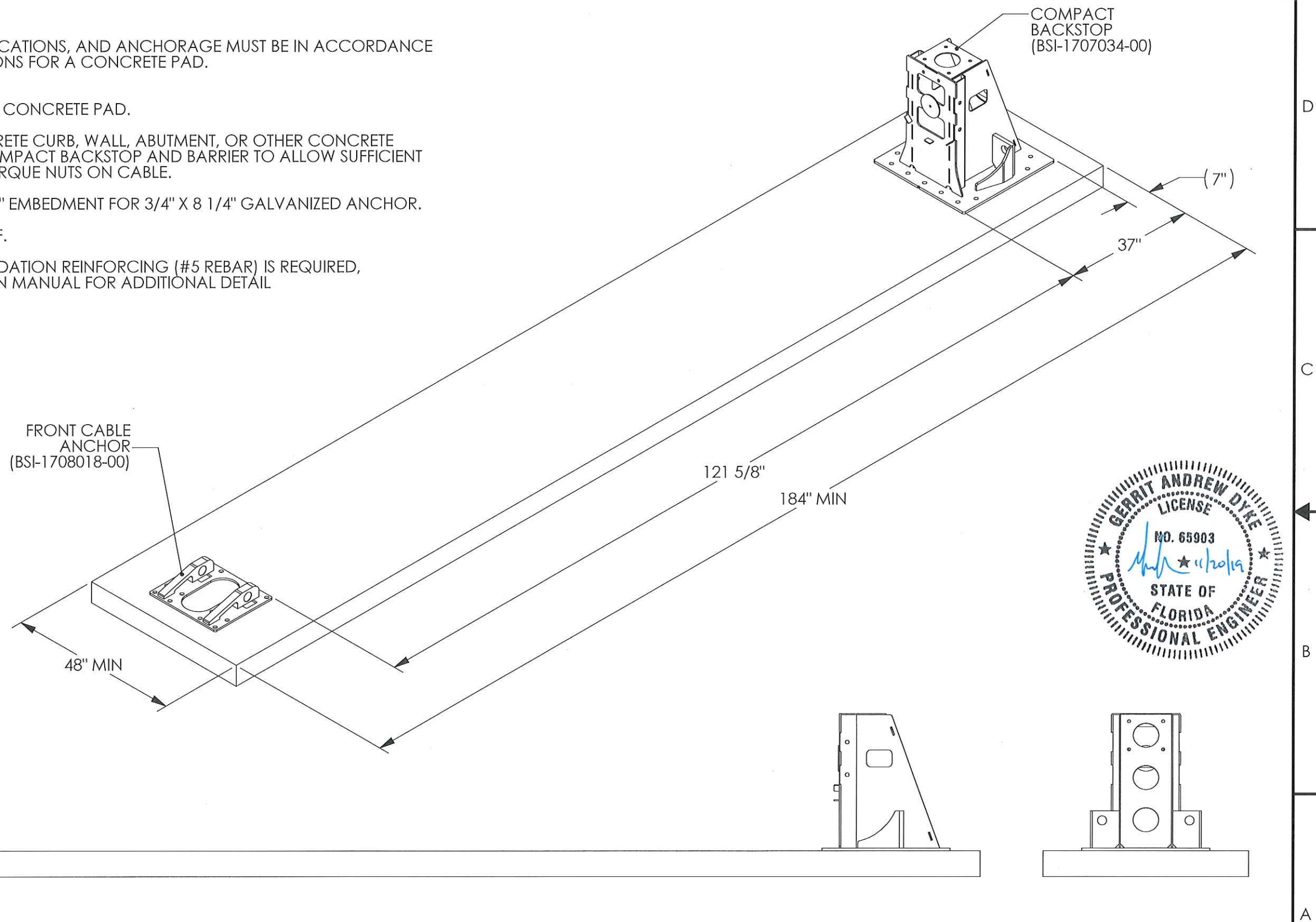

UNIVERSAL TAU-M FOUNDATION, CONCRETE PAD

| | | |
|------------------|----------------------------------|------------------|
| SIZE B | DWG NO. BSI-1903002-AP | REV. C |
| SCALE 1:24 | FDOT APL 544-002-001 | SHEET 3 OF 11 |

NOTES:

- 1. THE UNIVERSAL TAU-M CRASH CUSHION SYSTEM HAS BEEN DESIGNED TO ATTACH TO CONCRETE OR ASPHALT FOUNDATIONS. FOR PERMANENT APPLICATIONS, FDOT REQUIRES THE USE OF A CONCRETE FOUNDATION. USE THE ANCHORAGE SPECIFIED BELOW DEPENDING ON THE FOUNDATION AT THE JOB SITE. REFER TO TAU-M FOUNDATION DRAWINGS.
- 2. FOR CHEMICAL ANCHORS, USE 3/4" GRADE 2 THREADED ROD WITH EPOXY PROVIDING A MINIMUM PULL OUT STRENGTH OF 39,000 LBF AND MINIMUM SHEAR STRENGTH OF 32,000 LBF IN 4,000 PSI CONCRETE.

CONCRETE PAD

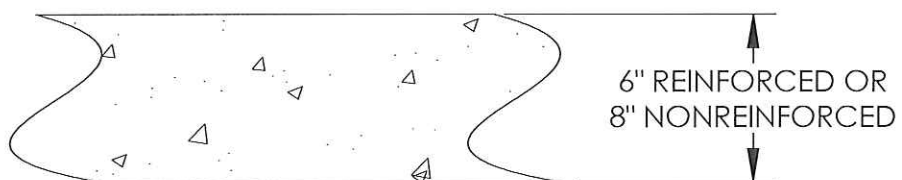

PORTLAND CEMENT CONCRETE (PCC)

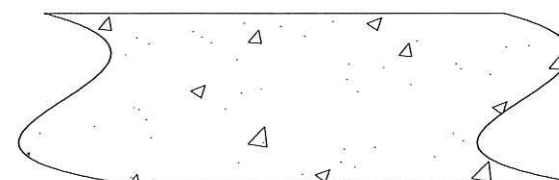

FOUNDATION: MINIMUM 6IN. REINFORCED CONCRETE PAD OR 8IN. NONREINFORCED CONCRETE PAD.

ANCHORAGE: 3/4 IN. X 8 1/4 IN. GALVANIZED ANCHOR WITH 6IN. EMBEDMENT OR 3/4" MECHANICAL ANCHORS WITH AN EMBEDMENT THAT IS IN ACCORDANCE WITH ANCHOR MANUFACTURER'S SPECIFICATIONS AND MEETS PULL OUT AND SHEAR STRENGTH REQUIREMENTS REFERENCED IN NOTE 2 ABOVE.

STONE AGGREGATE CONCRETE MIX 4,000 PSI MINIMUM COMPRESSIVE STRENGTH.

THE CONTRACTOR IS TO FURNISH A CERTIFICATION THAT THE CONCRETE INSTALLED MEETS THE STRENGTH REQUIREMENTS.

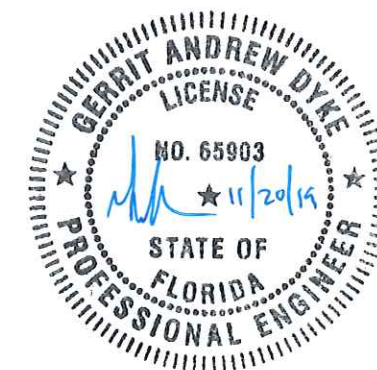

UNIVERSAL TAU-M FOUNDATION SPECIFICATIONS

| | | |
|------------------|----------------------------------|------------------|
| SIZE B | DWG NO. BSI-1903002-AP | REV. C |
| SCALE NTS | FDOT APL 544-002-001 | SHEET 4 OF 11 |

NOTES:

- THIS DRAWING ILLUSTRATES A 4-BAY TL-2 TAU-M WITH A COMPACT BACKSTOP TO DEPICT THE OVERALL SYSTEM COMPONENT LAYOUT.

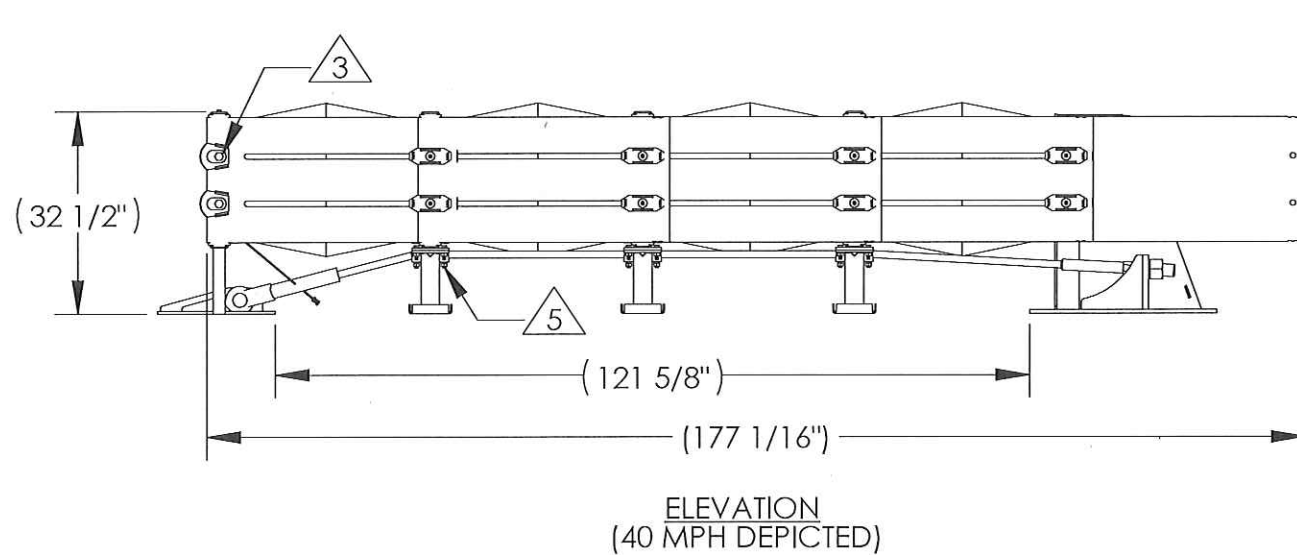
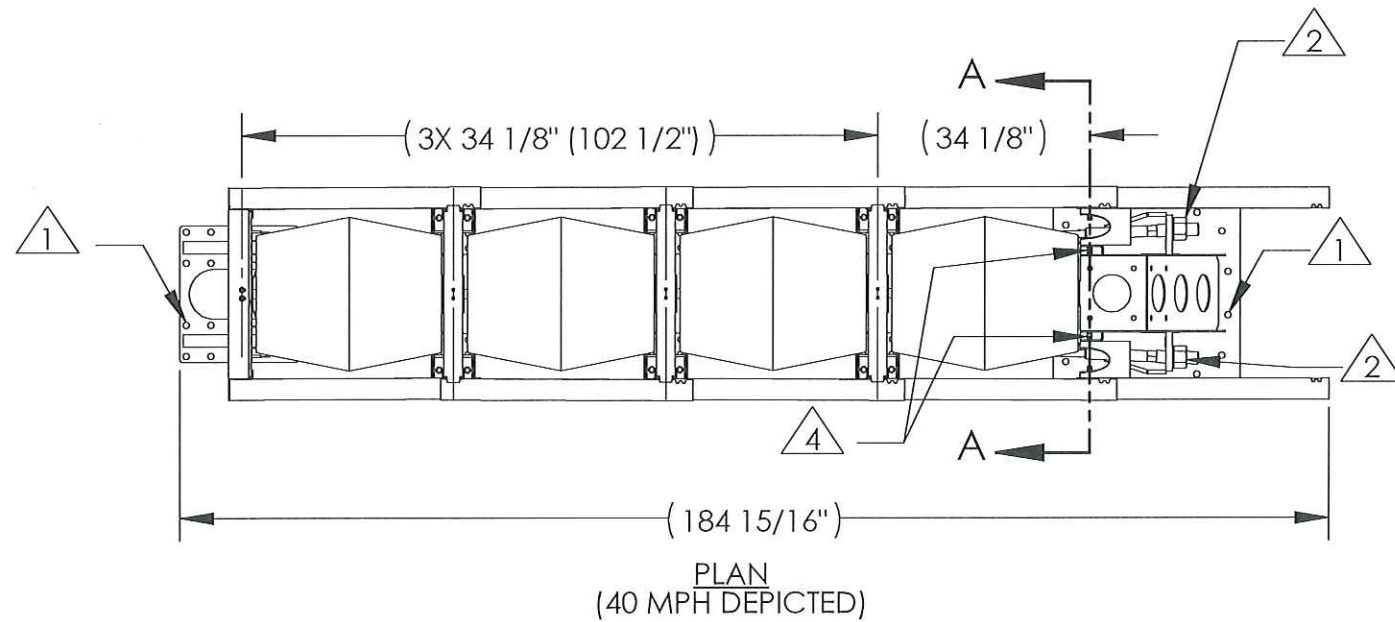

LEGEND:

TORQUE REQUIREMENT, SEE CHART

| TAU-M SYSTEM TORQUE CHART | | |
|-------------------------------|-----------------------------|----------------------|
| CONCRETE INSTALLATION | | |
| 1 | COMPACT BACKSTOP ANCHORS | 120 ft-lbs (160 N-m) |
| 1 | CABLE ANCHOR (FRONT) | 120 ft-lbs (160 N-m) |
| 2 | CABLE NUTS | 500 ft-lbs (675 N-m) |
| SYSTEM COMPONENT INSTALLATION | | |
| 3 | TOW HOOKS | 120 ft-lbs (160 N-m) |
| 4 | END PANEL MOUNT TO BACKSTOP | 70 ft-lbs (95 N-m) |
| 5 | CABLE GUIDE BOLTS | 30 ft-lbs (48 N-m) |

UNIVERSAL TAU-M TEST LEVEL 2 SYSTEM LAYOUT

| ITEM | PART NO. | Description | QTY |
|------|----------------|---|-----|
| 1 | B030703 | MIDDLE SUPPORT ASSEMBLY | 3 |
| 2 | BSI-1708032-00 | END PANEL MOUNT, GALVANIZED, TAU-M | 4 |
| 3 | B010722 | CARTRIDGE, TAU-II, TYPE B, ENERGY ABSORBING | 4 |
| 4 | BSI-1708019-00 | SLIDING PANEL, GALVANIZED, TAU-M | 8 |
| 5 | BSI-1708030-00 | END PANEL, THRIE-BEAM, GALVANIZED, TAU-M | 2 |
| 6 | B030704 | FRONT SUPPORT | 1 |
| 7 | K001005 | TAU-II FRONT SUPPORT LEG KIT | 1 |
| 8 | BSI-1708018-00 | GALVANIZED CABLE ANCHOR, TAU-M, PARALLEL | 1 |
| 9 | K001003 | TAU II SLIDER KIT | 4 |
| 10 | BSI-1707032-00 | GALVANIZED CABLE GUIDE, TAU-M | 6 |
| 11 | 2001791 | WASHER SL, 1/2" STANDARD, FINISH: GEOMET | 24 |
| 12 | 2001797 | NUT HN, 1/2-13, GR5, FINISH: GEOMET | 24 |
| 13 | BSI-2001957 | C-Scr HH 1/2-13 x 3 1/4, Gr5 Geomet, PARTIALLY THREADED | 24 |
| 14 | BSI-1805036-00 | CABLE ASSEMBLY, 4 BAY, TAU-M | 2 |
| 15 | 2001789 | NUT HN, 3/4-10, GR5, FINISH: GEOMET | 8 |
| 16 | 2001790 | WASHER FLAT, 3/4" STD, FINISH: GEOMET | 12 |
| 17 | BSI-2001956 | C-Scr HH 3/4-10 x 3 1/2, Gr5 Geomet, PARTIALLY THREADED | 4 |
| 18 | BSI-1708027-00 | BRACKET, DELINEATION TAU-M | 1 |
| 19 | 2001795 | C-SCR HH, 3/4-10 X 2, GR5, FINISH: GEOMET | 4 |
| 20 | 2001810 | WASHER FLAT, 3/8" STANDARD, FINISH: GEOMET | 4 |
| 21 | 2001811 | WASHER SL, 3/8" STANDARD FINISH: GEOMET | 2 |
| 22 | 2001809 | NUT HN, 3/8-16, GR5, FINISH: GEOMET | 2 |
| 23 | 2001816 | C-SCR HH, 3/8-16 X 1 1/2, GR5 FINISH: GEOMET | 2 |
| 24 | BSI-1709083-KT | TETHER KIT, TAU-M | 1 |
| 25 | BSI-1711051-00 | TOW HOOK, GALVANIZED, TAU-M | 4 |
| 26 | BSI-1803016-00 | SLIDER SHIM, GEOMET, TAU-M | 16 |
| * 27 | B011001 | THREADED ANCHOR 3/4-10x8 1/4 Gr2 | 25 |
| * 28 | 2001399 | NUT HN 3/4-10 HVY A563 HD GALV | 25 |
| * 29 | 2001380 | WSHR 3/4 F436 FLAT RD STRUCT | 25 |
| * 30 | 4004301 | EPXY ULTB 1, A22+1 NOZL | 2 |
| 31 | BSI-1707034-00 | COMPACT BACKSTOP, GALVANIZED TAU-M, PARALLEL | 1 |

* NOT SHOWN, USE FOR CONCRETE FOUNDATIONS

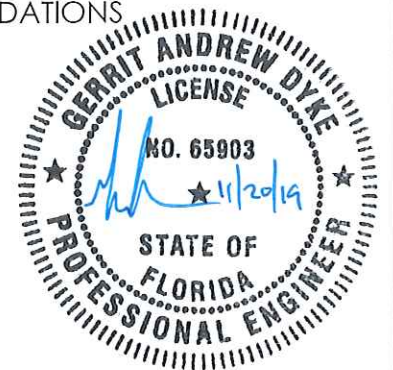

| | | |
|------------------|----------------------------------|------------------|
| SIZE B | DWG NO. BSI-1903002-AP | REV. C |
| SCALE 1:30 | FDOT APL 544-002-001 | SHEET 5 OF 11 |

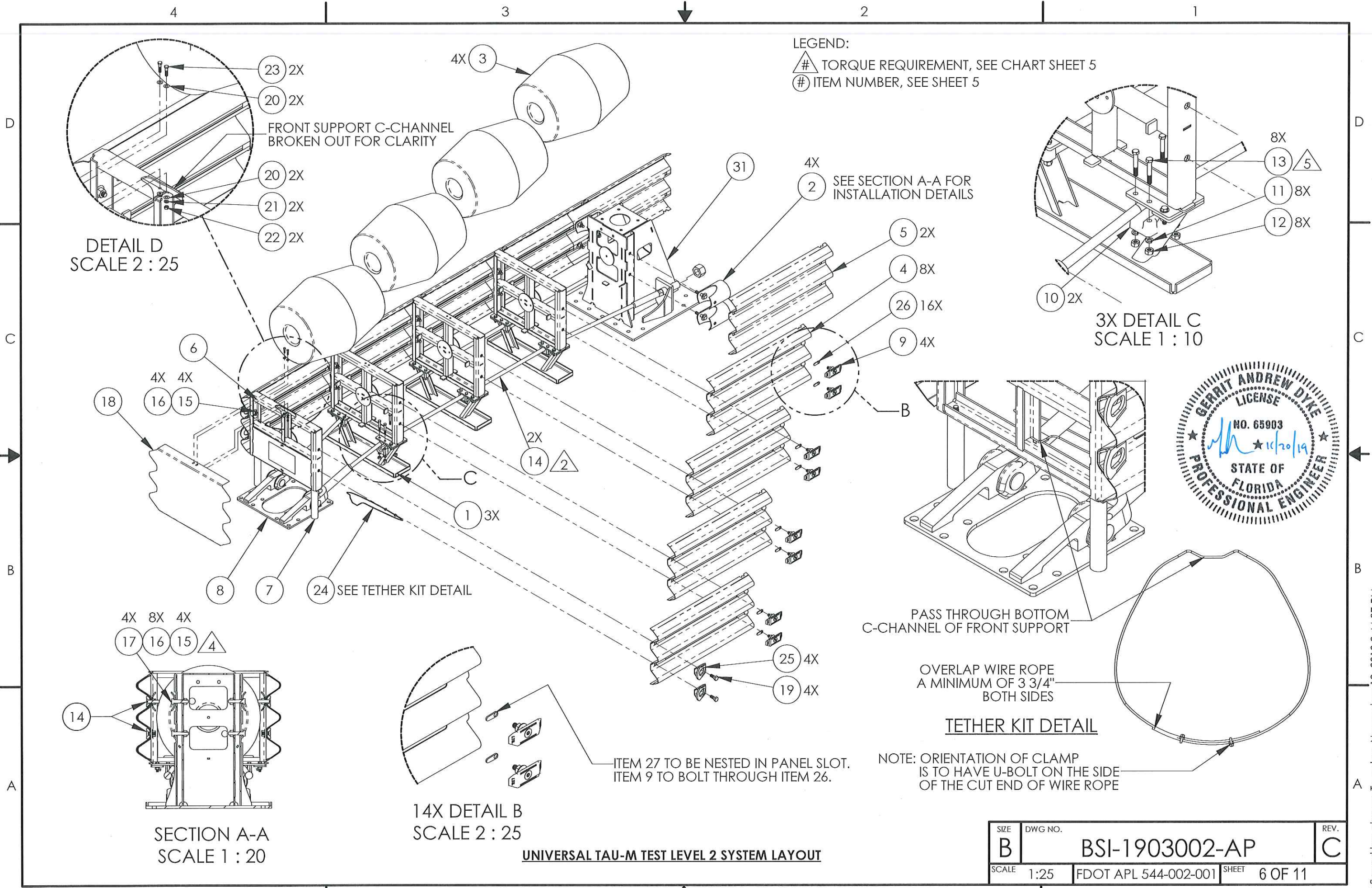

LEGEND:
 # TORQUE REQUIREMENT, SEE CHART SHEET 5
 # ITEM NUMBER, SEE SHEET 5

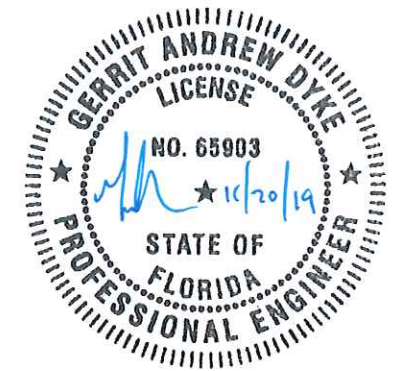

DETAIL D
SCALE 2 : 25

3X DETAIL C
SCALE 1 : 10

SECTION A-A
SCALE 1 : 20

14X DETAIL B
SCALE 2 : 25

UNIVERSAL TAU-M TEST LEVEL 2 SYSTEM LAYOUT

PASS THROUGH BOTTOM C-CHANNEL OF FRONT SUPPORT

OVERLAP WIRE ROPE A MINIMUM OF 3 3/4" BOTH SIDES

TETHER KIT DETAIL

NOTE: ORIENTATION OF CLAMP IS TO HAVE U-BOLT ON THE SIDE OF THE CUT END OF WIRE ROPE

ITEM 27 TO BE NESTED IN PANEL SLOT.
ITEM 9 TO BOLT THROUGH ITEM 26.

| | | |
|------------------|----------------------------------|------------------|
| SIZE B | DWG NO. BSI-1903002-AP | REV. C |
| SCALE 1:25 | FDOT APL 544-002-001 | SHEET 6 OF 11 |

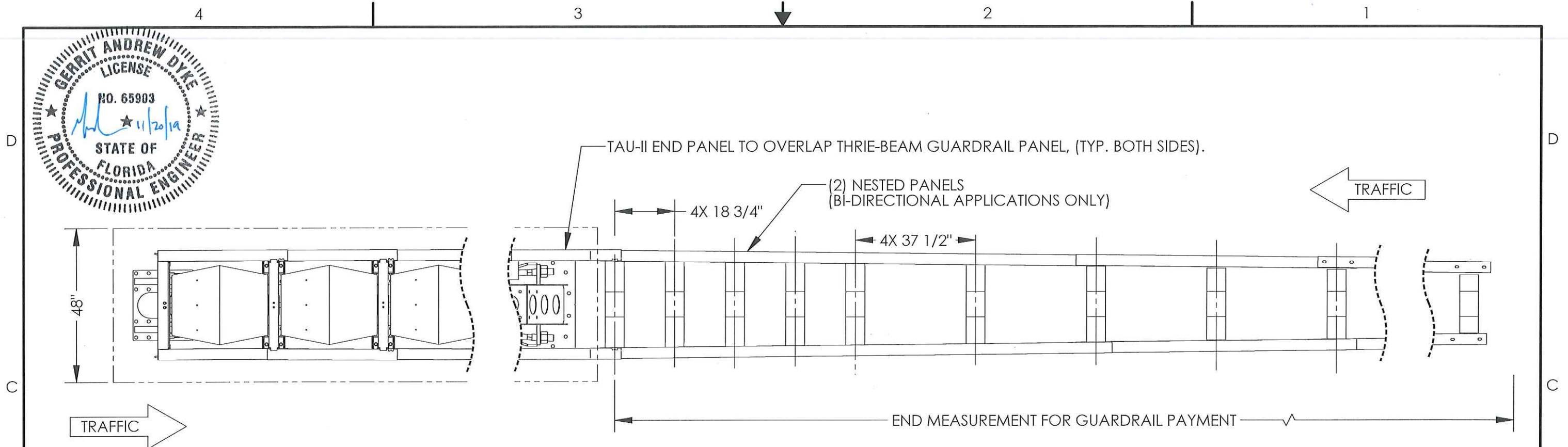
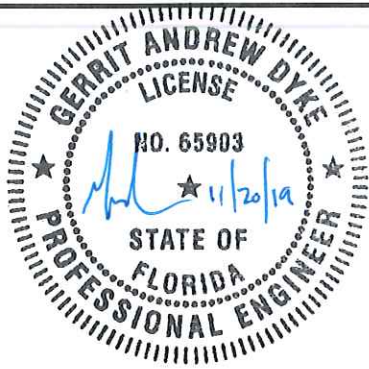

PLAN

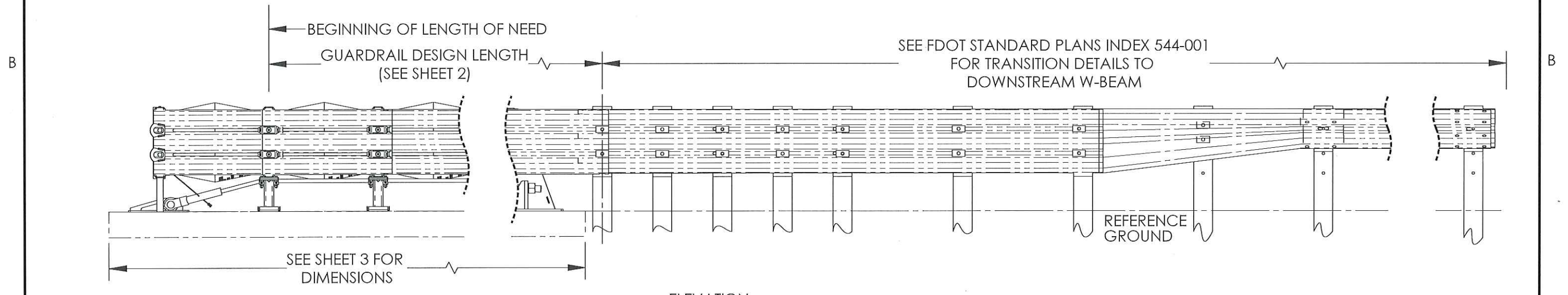

ELEVATION

UNIVERSAL TAU-M TRANSITION TO W-BEAM GUARDRAIL

| | | |
|------------------|----------------------------------|------------------|
| SIZE B | DWG NO. BSI-1903002-AP | REV. C |
| SCALE 1:24 | FDOT APL 544-002-001 | SHEET 7 OF 11 |

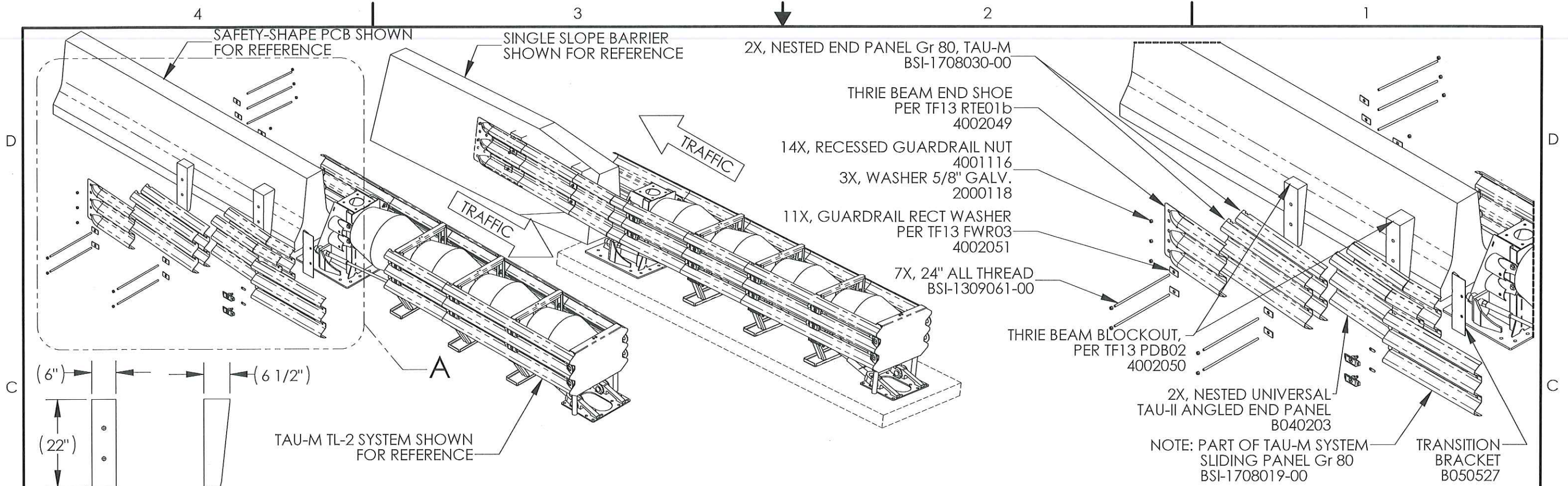

DETAIL A
SCALE 1 : 30

NOTES: UNLESS OTHERWISE SPECIFIED.

1. TAU-M TO BE INSTALLED PER MANUFACTURER'S INSTRUCTIONS.
2. TRANSITION SHOWN IS COMPATIBLE WITH COMPACT BACKSTOP (SHOWN).
3. THRIE BEAM TERMINAL CONNECTOR PER TASK FORCE 13 HARDWARE GUIDE RTE01b.
4. STANDARD TIMBER BLOCKOUT TO BE FIELD TRIMMED AS REQUIRED. DETAIL SHOWS DIMENSIONS FOR F-SHAPE SAFETY SHAPED BARRIER. ACTUAL DIMENSIONS SHOULD REFLECT SHAPE OF BARRIER TRANSITIONED TO.
5. PANELS AND BLOCKOUTS ATTACHED TO BARRIER WALL WITH 5/8" [16mm] BOLTS WITH BEAM WASHERS, FLAT WASHERS AND NUT. 24" [610mm] THREADED ROD MAY BE FIELD TRIMMED. LENGTH MAY VARY WITH DIFFERENT BARRIER SHAPES. HOLES DRILLED THROUGH MEDIAN BARRIER ARE 3/4" [20mm]. MECHANICAL OR CHEMICALLY BONDED ANCHORS MAY BE USED THAT MEET OR EXCEED 15000 LBF SHEAR AND PULL OUT STRENGTH.
6. ATTACH THRIE BEAM END SHOE TO MEDIAN BARRIER WITH (3) 5/8" [16mm] THREADED ROD WITH BEAM WASHERS, FLAT WASHERS, AND NUTS. THREADED ROD MAY BE FIELD TRIMMED. REFERENCE NOTE 5 FOR DETAILS.
7. TRANSITION BRACKET TO BE INSTALLED OVER END PANEL MOUNTS UNDER THE (2) NESTED ANGLED END PANELS AND THE SLIDING PANEL. BEND IN TRANSITION BRACKET FACES REARWARD AND FIT AROUND END PANEL MOUNTS. JOINT IS SECURED WITH SLIDING BOLTS.
8. THIS TRANSITION CAN BE USED WITH EITHER SAFETY SHAPE MEDIAN BARRIER, SINGLE SLOPE MEDIAN BARRIER, OR FDOT MEDIAN BARRIER END SEGMENT FOR GUARDRAIL CONNECTION.

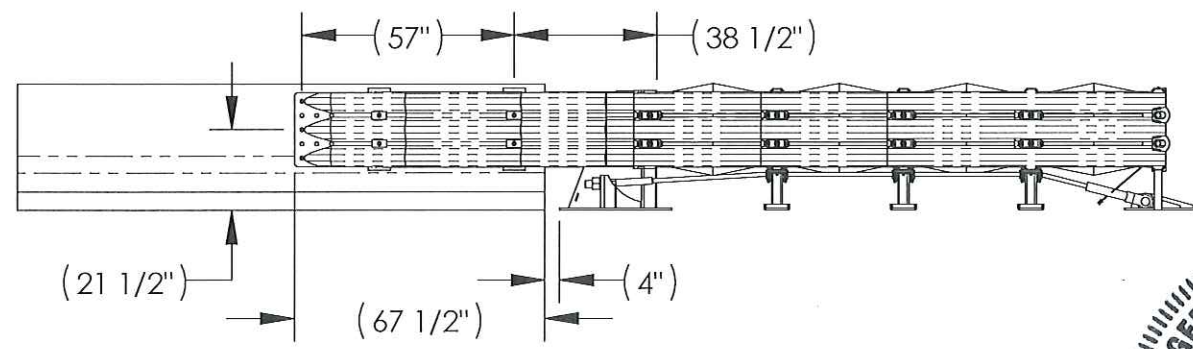

UNIVERSAL TAU-M BIDIRECTIONAL TRANSITION

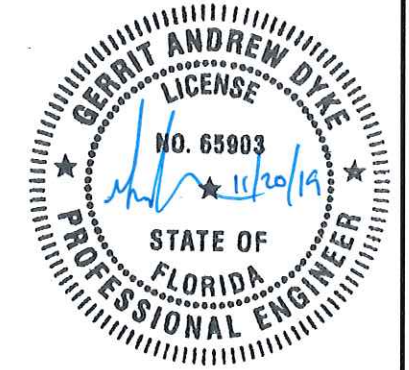

| | | |
|------------------|----------------------------------|------------------|
| SIZE B | DWG NO. BSI-1903002-AP | REV. C |
| SCALE 1:30 | FDOT APL 544-002-001 | SHEET 8 OF 11 |

NOTES: UNLESS OTHERWISE SPECIFIED.

- 1. REINFORCEMENT OF CONCRETE END SHOE MAY BE NEEDED. REFER TO LTS SPECIFICATION A0401 13 FOR FOUNDATION REQUIREMENTS.
- 2. THRIE BEAM END SHOE PER TASK FORCE 13 HARDWARE GUIDE RTE01b. ATTACH THRIE BEAM END SHOE TO MEDIAN BARRIER WITH (3) 5/8" [16mm] THREADED ROD WITH BEAM WASHERS, FLAT WASHERS, AND NUTS. THREADED ROD MAY BE FIELD TRIMMED. REFERENCE NOTE 5 FOR DETAILS.
- 3. RECTANGULAR GUARDRAIL WASHER PER TASK FORCE 13 HARDWARE GUIDE FWR03.
- 4. TAU-M SYSTEM TO BE INSTALLED PER MANUFACTURER'S INSTRUCTIONS.
- 5. END PANEL MUST OVERLAP END SHOE TO INSURE PROPER FUNCTION OF TAU-M SYSTEM
- 6. WIDTH IN EXCESS OF 24" [610 mm] MUST CHAMFER CORNERS.
- 7. 30" HAZARD CAN BE SHIELDED BY SPREADING END PANELS PRIOR TO TORQUING SLIDER BOLTS AT END PANEL MOUNTS.
- 8. THRIE BEAM END SHOES REQUIRED ON BOTH SIDES OF CONCRETE BLOCK REGARDLESS OF TRAFFIC DIRECTION.

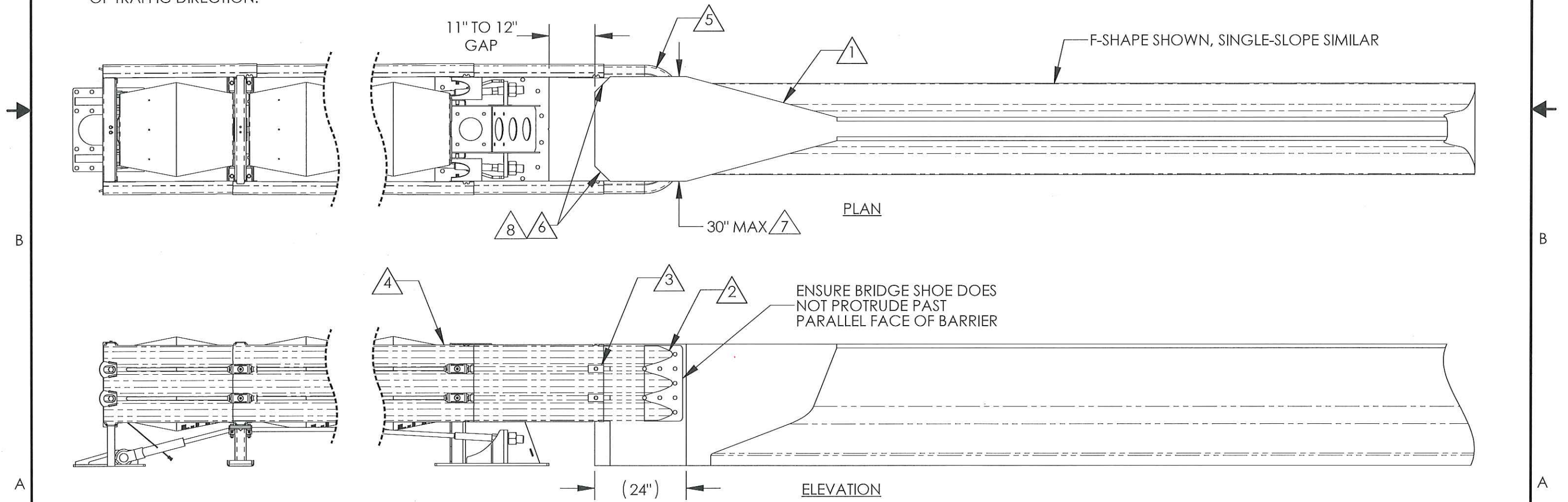
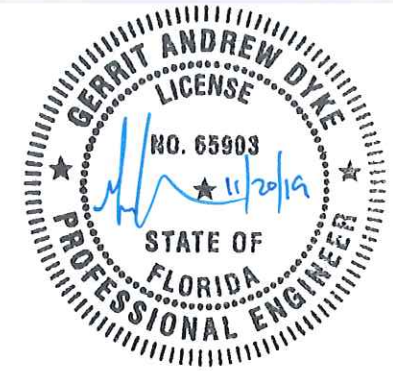

UNIVERSAL TAU-M TRANSITION TO CONCRETE BARRIER WITH END SHOE

| | | |
|------------------|----------------------------------|------------------|
| SIZE B | DWG NO. BSI-1903002-AP | REV. C |
| SCALE 1:24 | FDOT APL 544-002-001 | SHEET 9 OF 11 |

NOTES: UNLESS OTHERWISE SPECIFIED.

1. THRIE BEAM END SHOE PER TF13 HARDWARE GUIDE RTE01b.
2. RECTANGULAR GUARDRAIL WASHER PER TF13 HARDWARE GUIDE FWR03.
3. TAU-M SYSTEM TO BE INSTALLED PER MANUFACTURER'S INSTRUCTIONS. REFER TO LTS SPECIFICATION A040113 FOR FOUNDATION REQUIREMENTS.
4. END PANEL MUST OVERLAP END SHOE TO INSURE PROPER FUNCTION OF TAU-M SYSTEM.
5. ATTACH THRIE BEAM END SHOE TO MEDIAN BARRIER WITH (3) 5/8" [16mm] THREADED ROD WITH BEAM WASHERS, FLAT WASHERS, AND NUTS. THREADED ROD MAY BE FIELD TRIMMED.
6. THIS TRANSITION CAN BE USED WITH EITHER F-SHAPE OR SINGLE SLOPE CONCRETE BARRIER OR BRIDGE RAILING.

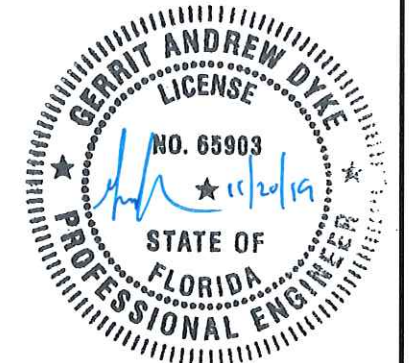
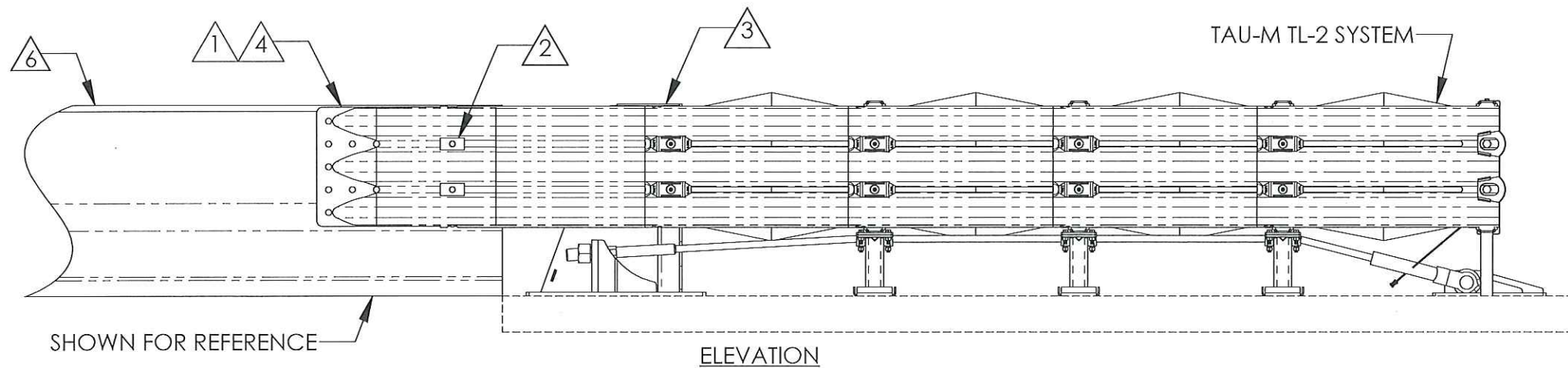
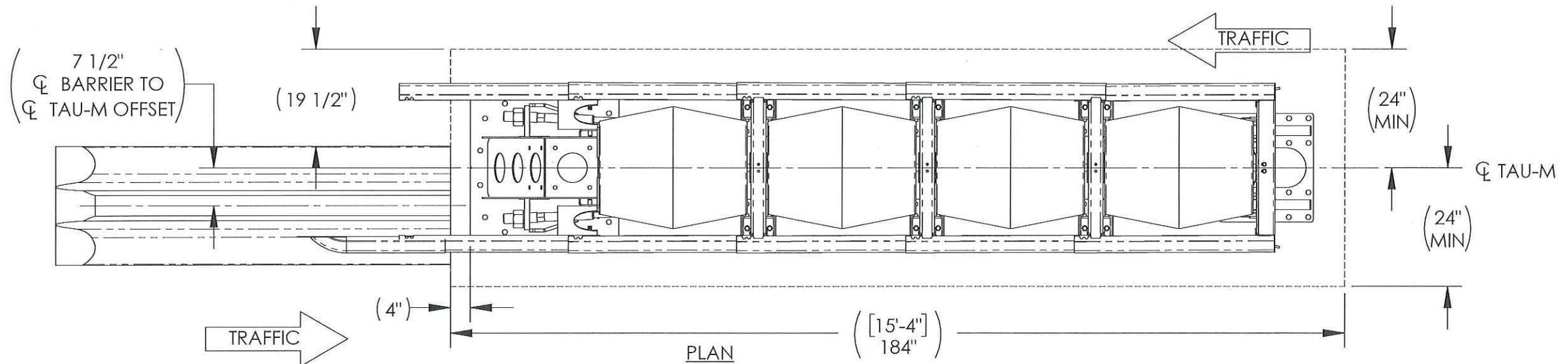

UNIVERSAL TAU-M TRANSITION TO OFFSET CONCRETE BARRIER WITH END SHOE

| | | |
|------------------|----------------------------------|------------------|
| SIZE B | DWG NO. BSI-1903002-AP | REV. C |
| SCALE 1:24 | FDOT APL 544-002-001 | SHEET 10 OF 11 |

NOTES UNLESS OTHERWISE SPECIFIED:

1. THE DETAILED METHOD FOR EXTENDING AN EXISTING CONCRETE PAD FOR USE WITH A UNIVERSAL TAU-M SYSTEM IS RECOMMENDED TO ENSURE ADEQUATE FOUNDATION INTEGRITY FOR PROPER IMPACT PERFORMANCE. VARIATIONS MAY BE REVIEWED AND DETERMINATIONS MADE AS TO EQUIVALENCE BY PROJECT ENGINEER.
2. FOR FOUNDATION DIMENSIONS REQUIRED, REFERENCE SHEET 3. EXTEND FOUNDATION PAD AS SHOWN FOR THE LENGTH REQUIRED.
3. THE REINFORCEMENT IN THE FOUNDATION EXTENSION IS #5 REBAR. THE LONGITUDINAL REINFORCEMENT IS EMBEDDED A MINIMUM OF 6" INTO THE EDGE OF THE EXISTING CONCRETE PAD AND BONDED IN PLACE. USE ANCHORING COMPOUND APPROVED FOR USE WITH THE UNIVERSAL TAU-M SYSTEM.
4. FOUNDATION MATERIAL, SPECIFICATIONS, AND ANCHORAGE MUST BE IN ACCORDANCE WITH BSI FOUNDATION SPECIFICATIONS FOR A CONCRETE PAD AND PORTLAND CEMENT CONCRETE SHOWN ON SHEET 4.
5. DETAIL BELOW SHOWS A 5 FT EXTENSION ON A 10FT-4IN EXISTING CONCRETE PAD.
6. EXTENSIONS UP TO 3 FT LONG TO BE A MINIMUM OF 18" THICK AND REINFORCED AS SHOWN. EXTENSIONS OVER 3 FT SHALL BE MINIMUM 6" THICK UP TO THE LAST 3 FT WHERE IT IS MINIMUM 18", REINFORCE AS INDICATED.

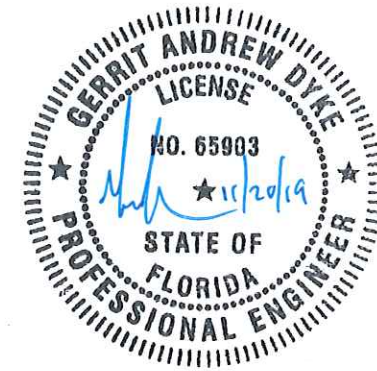
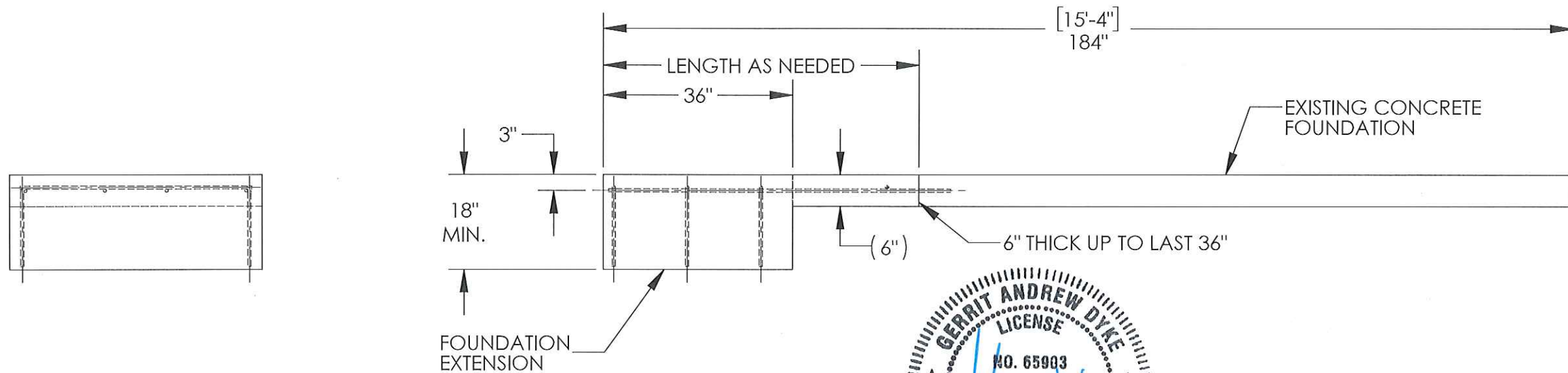
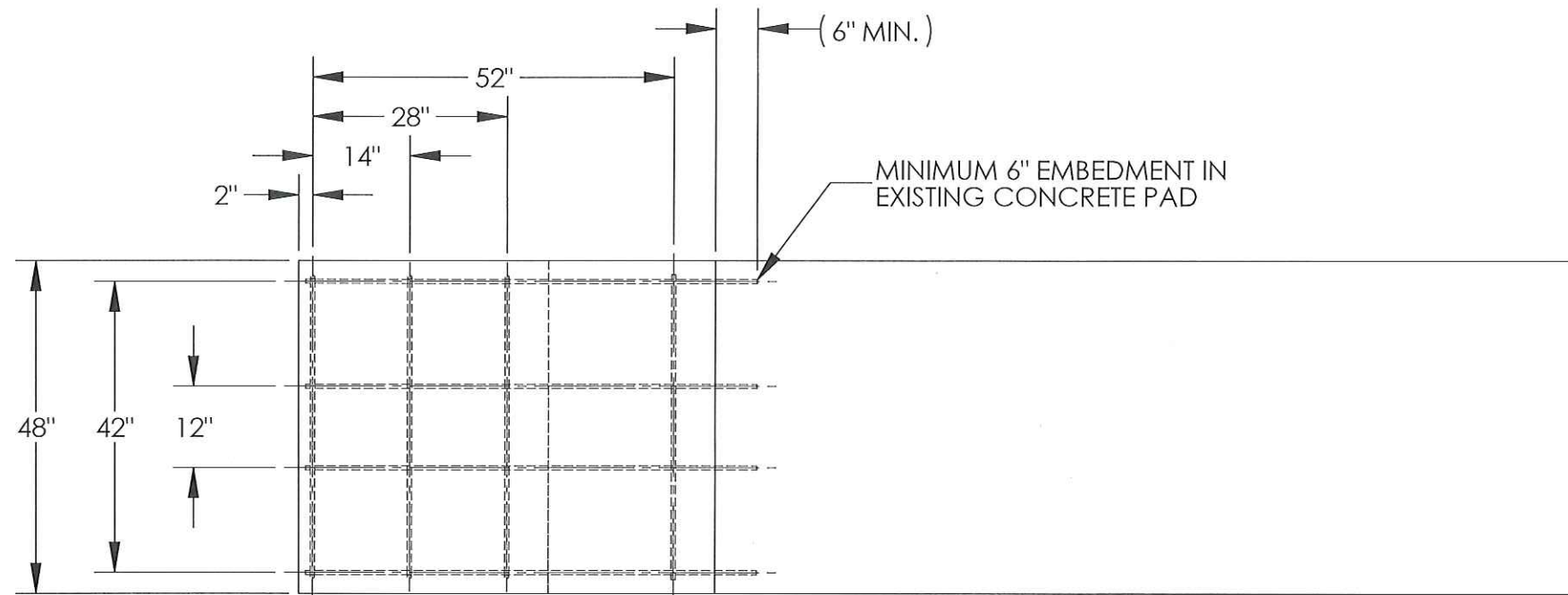

| | | |
|------------------|----------------------------------|-------------------|
| SIZE B | DWG NO. BSI-1903002-AP | REV. C |
| SCALE 1:24 | FDOT APL 544-002-001 | SHEET 11 OF 11 |