

# QuadGuard<sup>®</sup> M10 (24" Wide)

## Product Description Assembly Manual



**TRINITY**  
**HIGHWAY**

*Ahead of the Curve<sup>®</sup>*

# QuadGuard<sup>®</sup> M10 [24” Wide]

The QuadGuard<sup>®</sup> M10 system has been tested pursuant to American Association of State Highway and Transportation Officials (“AASHTO”) Manual for Assessing Safety Hardware (“MASH”) specifications. The Federal Highway Administration (“FHWA”) has determined that the QuadGuard<sup>®</sup> M10 system is eligible for federal-aid reimbursement on the National Highway System under the FHWA.

## Product Description Assembly Manual



2525 N. Stemmons Freeway  
Dallas, Texas 75207



**Important:** These instructions are to be used only in conjunction with the assembly, maintenance, and repair of the QuadGuard<sup>®</sup> M10 system. These instructions are for standard assembly specified by the appropriate highway authority. In the event the specified system assembly, maintenance, or repair would require a deviation from standard assembly parameters, contact a Trinity Highway representative. This system has been deemed eligible by the FHWA for use on the national highway system under strict criteria utilized by that agency.

**This manual must be available to the worker overseeing and/or assembling the product at all times. For additional copies, contact Trinity Highway directly at (888) 323-6374.**

The instructions contained in this manual supersede all previous information and manuals. The information, illustrations, and specifications in this manual are based on the latest QuadGuard<sup>®</sup> M10 system information available to Trinity Highway at the time of printing. We reserve the right to make changes at any time. Please contact Trinity Highway to confirm that you are referring to the most current instructions.

## **Table of Contents**

Customer Service Contacts .....	3
Important Introductory Notes .....	3
Safety Symbols .....	4
Safety Rules for Assembly .....	4
Limitations and Warnings.....	5
System Overview .....	6
Inspect Shipping.....	6
System Components.....	7
Determine Backup & Transition Type .....	11
System Transition .....	12
Recommended Tools.....	13
Site Preparation/Foundation .....	15
Foundation/Anchoring .....	16
Trinity Highway Approved Adhesive Anchoring System .....	17
Vertical Anchors .....	17
Anchor Assembly Cautions .....	18
Horizontal Anchors.....	19
System Assembly .....	22
Final Inspection Checklist .....	35
Maintenance and Repair.....	36
Inspection Frequency.....	36
Visual Drive-By Inspection .....	36
Walk-Up Inspection Checklist .....	36
Post-Impact Instructions.....	37
Parts Ordering Procedure .....	39
Parts List(s) & Quantities .....	39
QuadGuard® M10 24” with Tension Strut Backup.....	41
QuadGuard® M10 24” with Concrete Backup .....	42

## Customer Service Contacts

Trinity Highway is committed to the highest level of customer service. Feedback regarding the QuadGuard® M10 system, its assembly procedures, supporting documentation, and performance is always welcome. Additional information can be obtained from the contact information below:

### Trinity Highway

Telephone:	(888) 323-6374 (USA) +1 312 467-6750 (International)
E-mail:	product.info@trin.net
Website:	www.trinityhighway.com

## Important Introductory Notes

Proper assembly of the QuadGuard® M10 system is critical to achieve performance that has been evaluated and deemed eligible by the FHWA per AASHTO MASH criteria. These instructions should be read in their entirety and understood before assembling the QuadGuard® M10 system. These instructions are to be used in conjunction with the assembly of QuadGuard® M10 systems and are for standard assemblies only as specified by the applicable highway authority. If you need additional information, or have questions about the QuadGuard® M10 system, please contact the highway authority that has planned and specified this assembly and, if needed, contact Trinity Highway's Customer Service Department. This product must be assembled in the location specified by the appropriate highway authority. If there are deviations, alterations, or departures from the assembly protocol specified in this manual, the device may not perform as tested.



**Important: DO NOT** use any component part that has not been specifically approved for this system during the assembly or repair of this system (p. 7 – 10 / 39 - 40).

This product has been specified for use by the appropriate highway authority and has been provided to that user who has unique knowledge of how this system is to be assembled. No person should be permitted to assist in the assembly, maintenance, or repair of this system that does not possess the unique knowledge described above. These instructions are intended for an individual qualified to both read and accurately interpret them as written. These instructions are intended only for an individual experienced and skilled in the assembly of highway products that are specified and selected by the highway authority.

A Manufacturer's Drawing Package will be supplied by Trinity Highway upon request. Each system will be supplied with a specific drawing package unique to that system. Such drawings take precedence over information in this manual and shall be studied thoroughly by a qualified individual who is skilled in interpreting them before the start of any product assembly.

## Safety Symbols

This section describes the safety symbols that appear in this QuadGuard® M10 manual. Read the manual for complete safety and assembly information.

### Symbol

### Meaning



**Safety Alert Symbol:** Indicates Important, Caution, Warning, or Danger. Failure to read and follow the Important, Caution, Warning, or Danger indicators could result in serious injury or death to the workers and/or bystanders.



**Warning:** Read safety instructions thoroughly and follow the assembly directions and suggested safe practices before assembling, maintaining, or repairing the QuadGuard® M10 system. Failure to comply with these warnings could result in increased risk of serious injury or death in the event of a vehicle impact with a system.



**Important:** Please keep up-to-date instructions for later use and reference by anyone involved in the assembly of the product.

## Safety Rules for Assembly

### **\* Important Safety Instructions \***

This manual must be kept in a location where it is readily available to persons who are skilled and experienced in the assembly, maintenance, or repair of the QuadGuard® M10 system. Additional copies of this manual are available from Trinity Highway by calling (888) 323-6374, by email at [product.info@trin.net](mailto:product.info@trin.net), or at [www.trinityhighway.com](http://www.trinityhighway.com). Please contact Trinity Highway if you have any questions concerning the information in this manual or about the QuadGuard® M10 system.

Always use appropriate safety precautions when operating power equipment, mixing chemicals, and when moving heavy equipment or QuadGuard® M10 components. Safety articles including but not necessarily limited to work gloves, eye protection, safety-toe shoes, and back protection should be used.



**Warning:** Safety measures incorporating appropriate traffic control devices specified by the highway authority must be used to protect all personnel while at the assembly, maintenance, or repair site.

## Limitations and Warnings

Pursuant to MASH “Recommended Procedures for the Safety Performance of Highway Safety Features”, Trinity Highway contracts with FHWA approved testing facilities to perform and evaluate crash tests to prepare a crash test results report. Trinity Highway is then able to submit a Request for Federal Aid Reimbursement of Safety Hardware Devices to the FHWA for review.

The QuadGuard® M10 system has been deemed eligible by FHWA as meeting the requirements and guidelines of MASH. These tests evaluate product performance defined by AASHTO involving lightweight cars (approx. 1100 kg [2420 lb.]) and full size pickup trucks (approx. 2270 kg [5000 lb.]). A product can be certified for multiple Test Levels. The QuadGuard® M10 is certified to the Test Level(s) as shown below:

### **Test Level 3: 100 km/h [62 mph]**

**These AASHTO directed tests are not intended to represent the performance of systems when impacted by every vehicle type or every impact condition existing on the roadway. This system is tested only to the test matrix criteria of MASH as approved by FHWA.**

Trinity Highway expressly disclaims any warranty or liability for injury or damage to persons or property resulting from any impact, collision or harmful contact with products, other vehicles, or nearby hazards or objects by any vehicle, object or person, whether or not the products were assembled in consultation with Trinity Highway or by third parties.

The QuadGuard® M10 system is intended to be assembled, delineated, and maintained within specific state and federal guidelines. It is important for the highway authority specifying the use of a highway product to select the most appropriate product configuration for site specifications. The customer should be careful to properly select, assemble, and maintain the product. Careful evaluation of site layout, traffic speed/type, direction, and visibility are some of the elements that require evaluation by the highway authority in the selection of a highway product. For example, curbs could cause an untested effect on an impacting vehicle.

After an impact occurs, the debris from the impact should be removed from the area immediately and the specified highway product should be evaluated and restored to its original specified condition or replaced as the highway authority determines as soon as possible.



**Warning:** Do not assemble, maintain, or repair the QuadGuard® M10 system until you have read this manual thoroughly and completely understand it. Ensure that all Danger, Warning, Caution, and Important statements within the manual are completely followed. Please call Trinity Highway at (888) 323-6374 if you do not understand these instructions.



**Warning:** Ensure that all of the QuadGuard® M10 system Danger, Warning, Caution, and Important statements within the QuadGuard® M10 manual are completely followed. Failure to follow this warning could result in serious injury or death in the event of a collision.

## System Overview

The QuadGuard® M10 is a potentially reusable, re-directive, non-gating crash cushion for roadside features of 610 mm [24"] or greater in width with use of approved transitions. It consists of energy-absorbing cartridges surrounded by a framework of Quad-Beam™ Panels. The decision as to whether this product is reusable after impact rests within the sound discretion of the trained engineer, experienced in highway products, who is working at the direction of the local DOT, or appropriate highway authority, which specified and now owns the product.

The QuadGuard® M10 system utilizes two types of cartridges in a "staged" configuration that are designed and tested to address vehicles as defined by MASH for both lighter cars and heavier, high center-of-gravity vehicles.

### **Impact Performance**

The Six Bay QuadGuard® M10 system has successfully passed the requirements stipulated in MASH with both the light car and pickup trucks at speeds of up to **100 km/h [62 mph]** at redirection angles up to 25 degrees.

During head-on impact testing, within MASH criteria, the QuadGuard® M10 has been shown to telescope rearward to absorb the energy of impact. When impacted from the side, within the applicable MASH criteria, it has been shown to redirect the vehicle back toward its original travel path and away from the highway feature.



**Warning:** Ensure that the QuadGuard® M10 system and delineation used meet all federal, state, specifying agency, and local specifications.



**Warning:** Ensure that your assembly meets all appropriate Manual on Uniform Traffic Control Devices ("MUTCD") and local standards.

### **Inspect Shipping**

Before deploying the QuadGuard® M10 system, check the received parts against the shipping list supplied with the system. Make sure all parts have been received (p. 39 - 40).



**Important:** The Manufacturer's Drawing Package supplied with the QuadGuard® M10 system must be used with these instructions for proper assembly and should take precedence over these general instructions.





**Warning:** Do NOT modify the QuadGuard® M10 system in any way.

## System Components

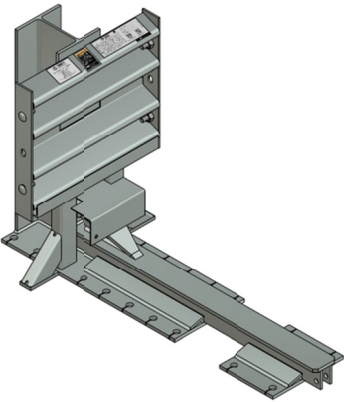
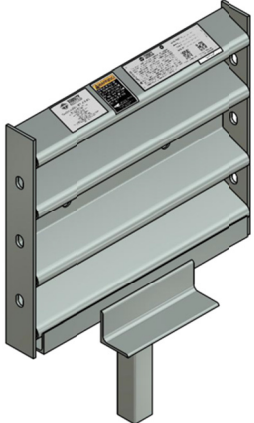
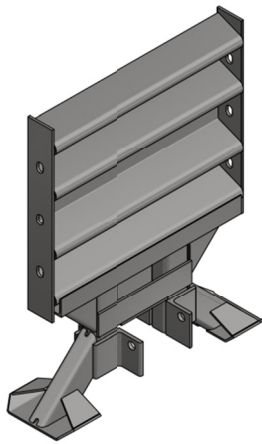
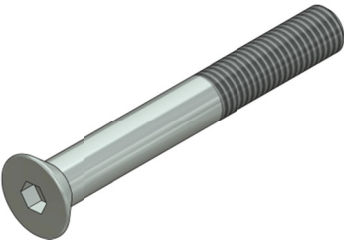

Below is a list of system components that may be used in your particular QuadGuard® M10 configuration. Verify parts delivered and system details with the BOM (Bill of Materials) and system drawings shipped with your system. Please call Trinity Highway if you have any system questions (p. 3).

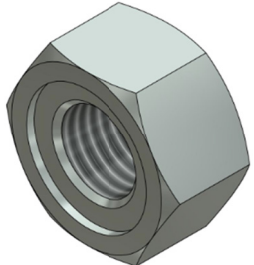
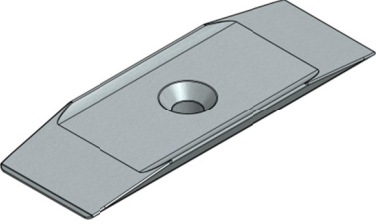
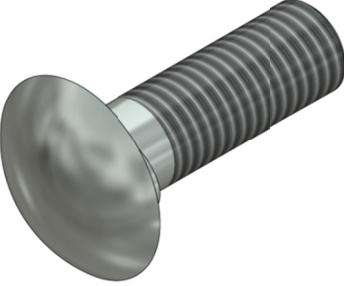
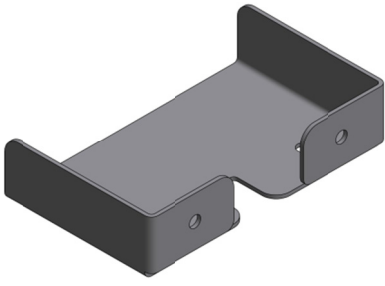

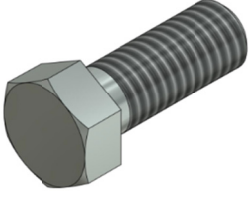
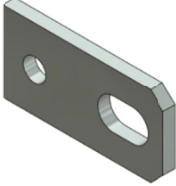
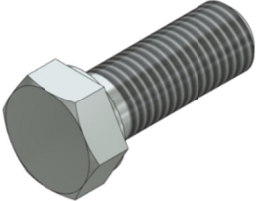
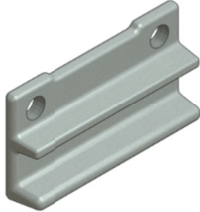

**Note:** Components are not shown to scale.

<p>Tension Strut Backup 24"</p>  <p>626055</p>	<p>Concrete Backup 24"</p>  <p>604663</p>	<p>Diaphragm 24"</p>  <p>607821</p>
<p>Flat Screw 5/8X5,G8</p>  <p>116878</p>	<p>Spring, Die 5/8 X 1 1/2</p>  <p>117459</p>	<p>Rail Nut, Hex, 5/8</p>  <p>003340</p>
<p>Mushroom Washer</p>  <p>617045</p>	<p>Rail Bolt, 5/8X2</p>  <p>003400</p>	<p>Bracket, Cart, Hold Down</p>  <p>617384</p>

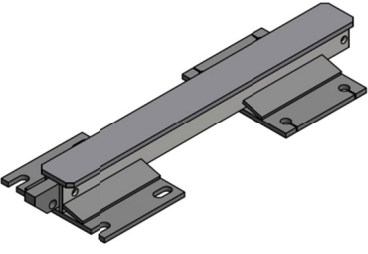
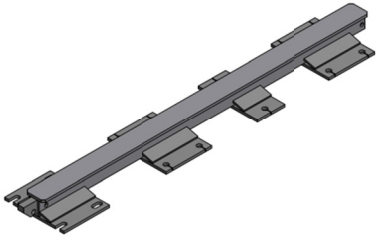
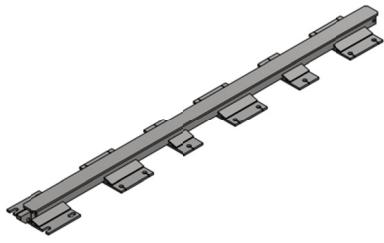
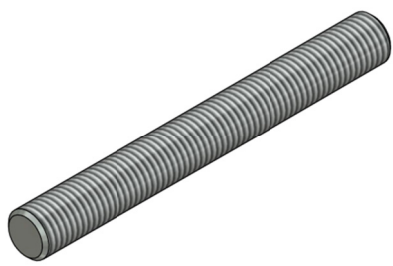

<p>Bracket, Cart Support, Nose</p>  <p>605430</p>	<p>Bracket, Cart, Nose</p>  <p>617383</p>	<p>Bracket, Cartridge Support</p>  <p>605446</p>
<p>Bolt, Hex 5/8X2 1/2, G5</p>  <p>118232</p>	<p>Bolt, Hex, 1/4X3/4, G5</p>  <p>113518</p>	<p>Bolt, Button, 5/8X1 1/4, Hex Sock.</p>  <p>113404</p>
<p>Bolt, Hex, 5/8X2, G5</p>  <p>118570</p>	<p>Nut, Hex, 1/4</p>  <p>115946</p>	<p>Nut, Hex, Coupling, 5/8X2 1/8</p>  <p>115986</p>
<p>Washer, Lock, 1/4</p>  <p>118085</p>	<p>Washer, Flat, 5/8X1 3/4</p>  <p>003300</p>	<p>Washer, Lock, 5/8</p>  <p>118100</p>
<p>Bracket, Angle, 2X1, W/Holes</p>  <p>617387</p>	<p>Washer, Flat 3/8X1</p>  <p>118036</p>	<p>Nut, Hex, 3/8</p>  <p>115960</p>

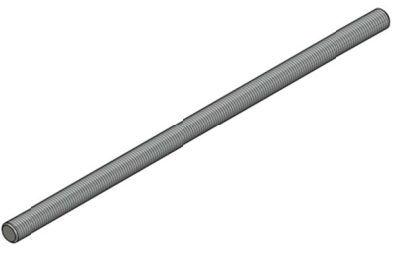
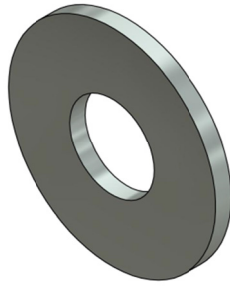
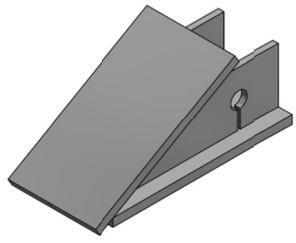
<p>Bolt, Hex, 3/8X1, G5</p> 	<p>Washer, Fender, 3/8X2</p> 	<p>Nut, Hex, 5/8</p> 
<p>113596</p>	<p>118038</p>	<p>115970 or 003354</p>
<p>Bracket, Pull-Out</p> 	<p>Shim, 1/8X3 5/8X8</p> 	<p>Washer, Lock, 3/4</p> 
<p>605535</p>	<p>614062</p>	<p>118089</p>
<p>Bolt, Hex, 3/4X2, G8</p> 	<p>Monorail Guide</p> 	<p>Nut, Heavy Hex, 3/4</p> 
<p>113555</p>	<p>611368</p>	<p>003704</p>
<p>Panel, Side, QG</p> 	<p>Bracket, Cartridge Support TS B/U</p> 	<p>Locking Bar, Cartridge Support</p> 
<p>611898</p>	<p>605447</p>	<p>611266</p>
<p>Cartridge Assy, Type M-I</p> 	<p>Cartridge Assy, Type M-II</p> 	<p>Bolt, Hex, 5/8X3 1/2, G5</p> 
<p>617412</p>	<p>617414</p>	<p>113660</p>

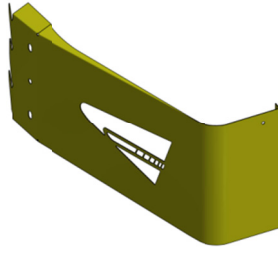
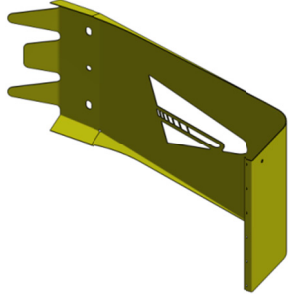
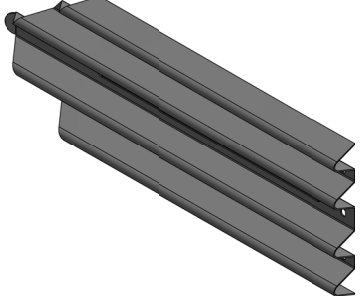
<p>Monorail, One Bay, QG, G</p>  <p>611370</p>	<p>Monorail, Two Bays, QG, G</p>  <p>611375</p>	<p>Monorail, Three Bays, QG, G</p>  <p>611379</p>
<p>Stud, 3/4X6 1/2, G5</p>  <p>117540</p>	<p>Stud, 3/4X7, G5</p>  <p>117542</p>	<p>Stud, 3/4X18, G5</p>  <p>116799</p>
<p>Washer, Flat, 3/4X2</p>  <p>118027</p>	<p>End Cap, Monorail, QG, G</p>  <p>608136</p>	<p>Approved Adhesive</p>  <p>118710</p>
<p>Nose, L, W/Logo</p>  <p>611669</p>	<p>Nose, R, W/Logo</p>  <p>611680</p>	<p>Panel, Fender, QG</p>  <p>611832</p>

## Determine Backup & Transition Type

The QuadGuard® M10 system is available with a **Tension Strut Backup** or a **Concrete Backup**. Refer to Figures 1 and 2, along with the Backup Assembly drawing, to determine which type of Backup is being deployed.

A Transition Panel or Side Panel must be used on each side of the Backup. A Side Panel is not needed when a Transition Panel is used. Several types of Transitions are available for use with the QuadGuard® M10 system. Refer to Figures 3 - 7 and the Drawing Package to determine which type of Panels to attach.

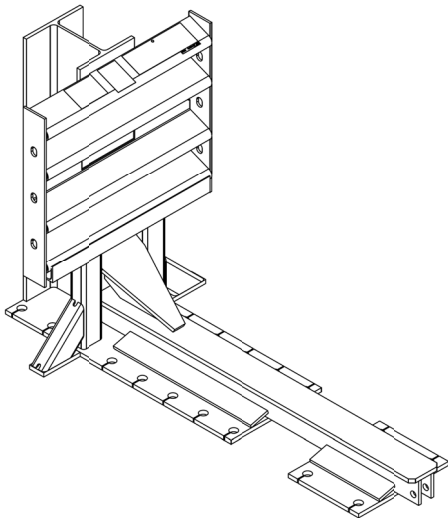

**Figure 1**  
**Tension Strut Backup**

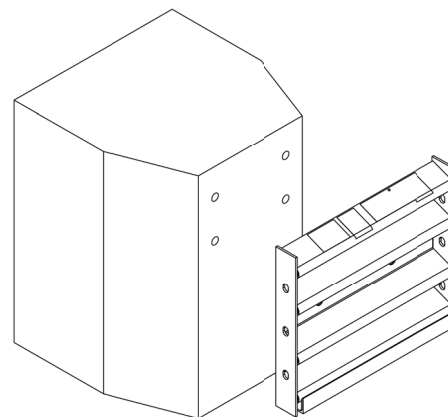

**Figure 2**  
**Concrete Backup**

## System Transition

**Note:** The proper Transition Panel or Side Panel must be used for impact performance of the system. The correct Panel(s) to use will depend on the direction of traffic and what type of barrier or road feature the QuadGuard® M10 system is shielding. Contact the Customer Service Department prior to deployment if you have any questions (p. 3).

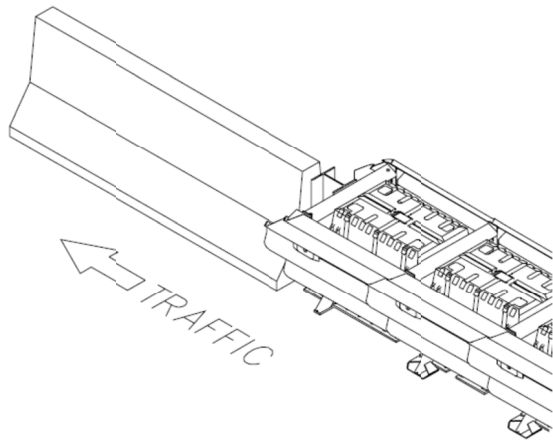

**Figure 3**  
No Transition

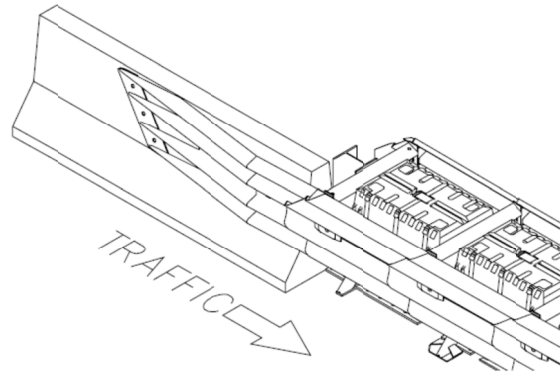

**Figure 4**  
Quad-Beam™ to Safety Shape Barrier

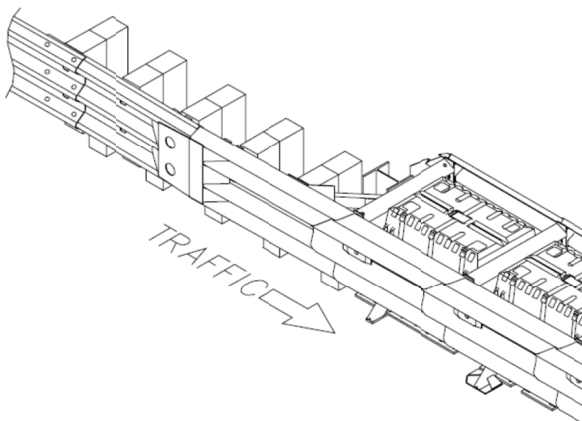

**Figure 5**  
Quad-Beam™ to Thrie-Beam

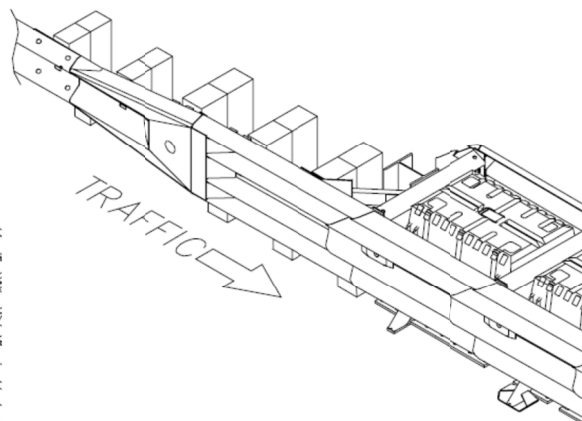

**Figure 6**  
Quad-Beam™ to W-Beam

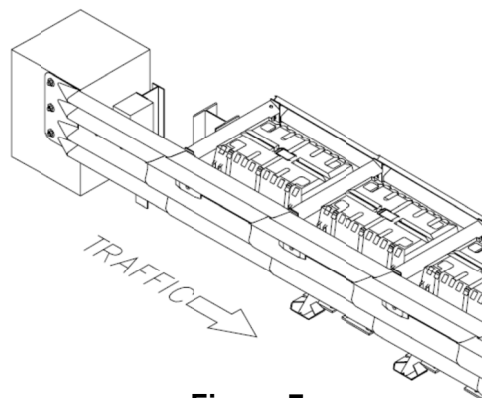

**Figure 7**  
Quad-Beam™ End Shoe

## Recommended Tools

### Documentation

- Manufacturer's Assembly Manual
- Manufacturer's Drawing Package

### Personal Protective equipment

- Eye Protection
- Gloves
- Safety-toe Shoes
- Protective Clothing

### Cutting equipment

- Rotary Hammer Drill
- Rebar cutting bit
- Concrete drill bits – 22 mm [7/8"] (**Double-Fluted**)
- Grinder, Hacksaw or Torch (optional)



**Important:** Trinity Highway recommends using **double-fluted** drill bits to achieve optimum tensile strength when applying an approved adhesive anchoring system (p. 17).

### Hammers

- Sledgehammer
- Standard hammer

### Wrenches

- Heavy duty 1/2" drive impact wrench
- 1/2" drive sockets: 7/16", 9/16", 15/16", 1 1/16", 1 1/8", 1 1/4"
- 1/2" drive Deep well sockets: 15/16", 1 1/4"
- 1/2" drive Ratchet and attachments
- 1/2" drive Breaker bar – 24" long
- 1/2" drive Torque wrench: 200 ft-lb
- Combination wrench(s): 7/16", 9/16", 15/16", 1 1/8"
- Hex Key (Allen) wrench: 3/8"



**Important:** Because every impact is different, Trinity Highway makes no recommendation whether use or reuse of any part of the system is appropriate or acceptable following an impact. It is the sole responsibility of the project engineer and/or the local highway authority and its engineers to make that determination. It is critical that you inspect this product after assembly is complete to make certain that the instructions provided in this manual have been strictly followed.

## Miscellaneous

- Traffic control equipment
- Lifting and moving equipment (A lifting device is preferred although a forklift can be used.) Minimum 5,000 lb. capacity required.
- Air Compressor (100 psi minimum) and Generator (5 kW)
- Long pry bar
- Drift pin 300 mm [12"]
- Center punch
- Tape measure 7.5 m [25']
- Chalk line
- Concrete marking pencil
- Steel bristled tube brush for cleaning 7/8" drilled boreholes
- Rags, water, and solvent for touch-up

**Note: The above list of tools is a general recommendation and should not be considered an extensive list. Depending on specific site conditions and the complexity of the assembly specified by the appropriate highway authority, the required tools may vary. Decisions as to what tools are needed to perform the job are entirely within the discretion of the specifying highway authority and the authority's selected contractor performing the assembly of the system at the authority's specified assembly site.**

## Site Preparation/Foundation

A QuadGuard® M10 should be assembled only on an existing or freshly placed and cured concrete base (28 MPa [4000 psi] minimum). Location and orientation of the concrete base and attenuator must comply with project plans or as otherwise determined by the local highway authority.

Recommended dimension and reinforcement specifications for new concrete foundations are provided in Trinity Highway concrete foundation drawings, supplied with the system. The system may be assembled on a non-reinforced concrete roadway (minimum 200 mm [8"] thick). Deployment cross-slope shall not exceed 8% and should not twist more than 2% over the length of the system; the foundation surface shall have a light broom finish.



**Warning:** Ensure that there is proper site grading for the QuadGuard® M10 system placement as dictated by the state or specifying agency pursuant to the AASHTO Roadside Design Guide.



**Caution:** Accurate placement of all steel rebar is critical to avoid interference with the concrete anchor bolts.

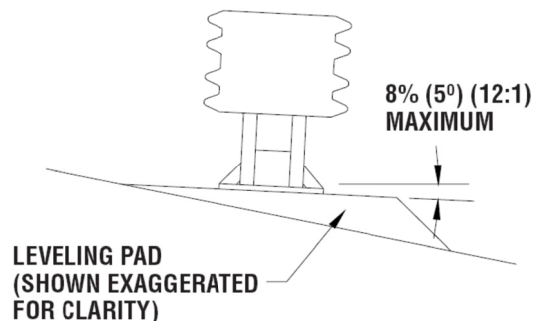

**Figure 8**  
**Cross-Slope**



**Warning:** Location of the Backup in relation to nearby objects will affect the operation of the attenuator. Upon impact, the Fender Panels telescope rearward and extend beyond the rigid Backup as much as 876 mm [34.5"]. Position the Backup so that the rear ends of the last Fender Panels are a minimum of 760 mm [30"] forward of objects that would otherwise interfere with movement of the rearmost Fender Panels. Failure to comply with this requirement is likely to result in system performance which has not been crash tested pursuant to MASH criteria and may also cause component damage which will necessitate maintenance or replacement of the system.



**Important:** Systems mounted on asphalt must be replaced and mounted on fresh, undisturbed asphalt if more than 10% of anchors are found to be loose, broken, or show signs of pull out. If 10% or fewer anchors are damaged, replace the damaged anchors in the existing asphalt. Anchor bolts used on systems mounted on asphalt must be inspected every 6 months. Review Maintenance and Repair Instructions and Post-Impact Instructions on pages 36-40.



## Foundation/Anchoring



**Warning:** Ensure that this assembly conforms with the guidance provided by the AASHTO Roadside Design Guide, including, but not limited to, those regarding placement on or adjacent to curbs.

### Asphalt Installations

Systems with a Tension-Strut Backup may be temporarily installed in construction zones on asphalt. Assemblies on **Asphalt Concrete (“A.C.”)** must provide a minimum of 76 mm [3”] layer of asphalt over a minimum of 76 mm [3”] layer of **Portland Cement Concrete (“P.C.C.”)**, 152 mm [6”] layer of asphalt over 152 mm [6”] layer of subbase, or 203 mm [8”] layer of asphalt with no subbase.



**Important:** Only 460 mm [18”] threaded rods, utilizing Trinity Highway approved adhesive, can be used with **asphalt** foundations. Contact Trinity Highway for a complete list of approved adhesives (p. 3).

### Concrete Installations

For concrete installations, the QuadGuard<sup>®</sup> M10 system should be installed only on an existing or freshly placed and cured concrete base (28 MPa [4000 psi] minimum). Orientation of the concrete base and the attenuator must comply with the project plans or as otherwise determined by the resident project engineer or appropriate highway authority.

Recommended dimension and reinforcement specifications for new concrete pads can be found on the standard drawings.

The QuadGuard<sup>®</sup> M10 system may be installed on any of the following foundations using the specified anchorage:

#### Foundation A: Reinforced Concrete Pad or Roadway

Foundation: 150 mm [6”] minimum depth P.C.C.

Anchorage: Approved adhesive with 180 mm [7”] studs 140 mm [5 1/2”] embedment

#### Foundation B: Asphalt over P.C.C.

Foundation: 76 mm [3”] minimum asphalt concrete (A.C.) over 76 mm [3”] minimum P.C.C.

Anchorage: Length of anchor required is 460 mm [18”] 420 mm [16 1/2”] embedment

#### Foundation C: Asphalt over Subbase

Foundation: 150 mm [6”] minimum A.C. over 150 mm [6”] minimum Compacted Subbase (C.S.)

Anchorage: Approved adhesive with 460 mm [18”] studs 420 mm [16 1/2”] embedment

#### Foundation D: Asphalt Only

Foundation: 200 mm [8”] minimum A.C.

Anchorage: Approved adhesive with 460 mm [18”] studs - 420 mm [16 1/2”] embedment

# Trinity Highway Approved Adhesive Anchoring System

A Trinity Highway approved adhesive anchoring system is required to securely anchor crash cushions. Each approved adhesive kit contains adhesive, studs, nuts and washers. Both vertical and horizontal assemblies are possible using an approved adhesive anchoring system.

## Vertical Anchors

**Note: Read all Trinity Highway approved adhesive instructions before starting.**

### 1) Prepare the Concrete Foundation



**Warning:** Do not allow anchoring adhesive to contact skin or eyes. See safety data sheet supplied with adhesive kit for first-aid procedures. Use only in well-ventilated area. Do not use near open flame.



**Warning:** Wear eye protection, apron, and gloves during application.

The anchor bolts (studs) that anchor the QuadGuard<sup>®</sup> M10 system Backup and/or Monorail sections to the concrete foundation must be those shipped in the kit or of high strength steel (830 MPa [120,000 psi] minimum tensile strength or equal). These studs must be set in minimum 28 MPa [4000 psi] concrete. Allow the concrete to cure a minimum of seven days before applying anchoring adhesive.

### 2) Drill Boreholes



**Caution: Consult OSHA silica respiratory standard 29 CFR 1910.134 for debris removal from borehole(s) and use Trinity Highway approved adhesive to achieve optimum tensile strength. Do not use diamond drill bits for drilling boreholes.**

Use the Monorail(s) and Tension Strut Backup as drilling templates. Use a rotary hammer drill to drill the boreholes 22 mm [7/8"] diameter to the recommended depth. See the approved adhesive instructions provided with adhesive kit. Check ensure each borehole is drilled to the proper depth and aligned with the part to be anchored (Table A).

Table A Anchoring Information				
Stud Size:	Orientation	Concrete Bit Size	Minimum Depth	Recommended Torque
3/4" x 6 1/2"	Horizontal	22 mm [7/8"]	133 mm [5 1/4"]	Consult Adhesive Kit Spec
3/4" x 7"	Vertical	22 mm [7/8"]	145 mm [5 3/4"]	Consult Adhesive Kit Spec
3/4" x 18"	Vertical	22 mm [7/8"]	425 mm [16 3/4"]	15 N-m [10 ft-lb] ⚠



**Important: When mounting on asphalt, initial torque shall be as shown in Table A. Due to the properties of asphalt, anchors may loosen over time. For this reason Trinity Highway recommends anchoring to asphalt only at temporary locations. It is recommended to re-torque anchors in asphalt every six (6) months to the proper initial torque specified.**

### 3) Clean the Boreholes

Blow the concrete dust from the borehole using oil-free compressed air. Thoroughly brush it with a 7/8" diameter steel bristle tube brush and then blow it out again. If the borehole is wet, completely flush it with water while brushing and then blow it clean to remove all water using oil-free compressed air.

### 4) Apply Approved Adhesive

Fill the borehole 100% full.



**Caution:** Fill borehole 100% full so it is even with the pavement surface per manufacturer's instructions.

### 5) Add the Washers and Nuts

Place a flat washer onto the stud then thread a nut on until the end of the stud is flush with the NUT (Figure 9).

### 6) Insert Studs in Boreholes and Wait for Adhesive to Cure

Push the stud down through the part to be anchored and into the borehole. Give the stud several twists in the approved adhesive to wet the threads.



**Caution:** Do not disturb or load the stud until the approved adhesive material has fully cured (reference instructions supplied with the approved adhesive kit).

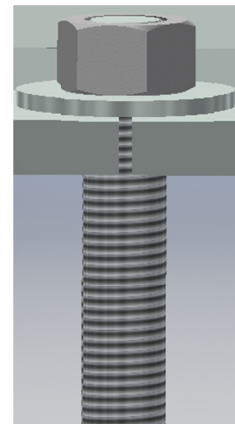

### 7) Torque the Nuts

Once the adhesive has fully cured, torque the nut to the adhesive manufacturer's recommended values (Table A).

**Figure 9**  
**Vertical Application**  
**(Before Applied Torque)**

## Anchor Assembly Cautions

### 1) Steel rebar

If steel rebar is encountered while drilling an anchor bolt borehole, apply one of the following solutions:

- A) Use a rebar drill bit for the **rebar only** and then switch back to the concrete bit to finish drilling into the underlying concrete until the proper borehole depth is reached.



**Caution:** Do not drill through rebar without first obtaining permission to do so from the project engineer.

- B) Drill a new borehole down at an angle past the rebar to the proper depth. Anchor the stud by completely filling both boreholes with an approved adhesive.

## Horizontal Anchors

The horizontal approved adhesive kit is the same as the vertical kit.



**Caution:** Fill borehole 100% full so it is even with the vertical concrete surface per manufacturer's instructions.

### 1) Follow the instructions supplied with your approved adhesive kit

Apply approved adhesive to each anchor per instructions.

### 2) Add the Washers and Nuts

Put washer and nut on stud so the **nut is flush with end of stud**.

### 3) Insert each Stud with Washer and Nut into Borehole

Push stud with washer and nut into borehole. Twist the stud in the approved adhesive to fully wet the threads.



**Important:** The stud should be flush with the top of the nut in both **vertical** and **horizontal** applications prior to tightening (Figure 10).

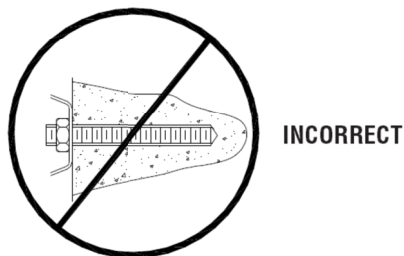
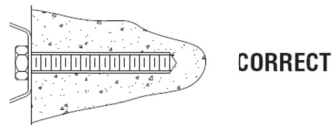

**Figure 10**  
**Horizontal Application**  
**(Before Applied Torque)**



**Caution:** Do not disturb or load the stud until the approved adhesive material has hardened (reference approved adhesive kit instructions for hardening times).

### 4) Torque the nuts

Once the adhesive has fully cured, torque nut(s) to the approved adhesive manufacturing specification.

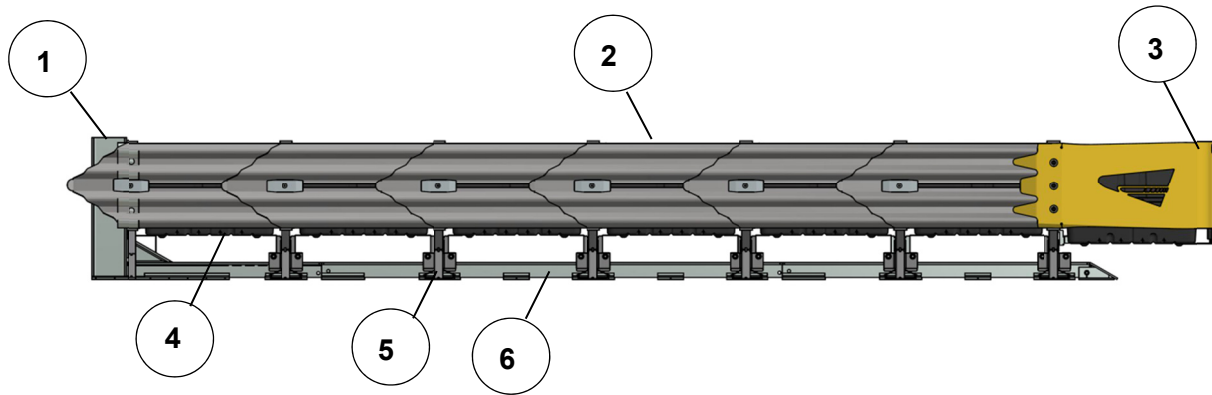
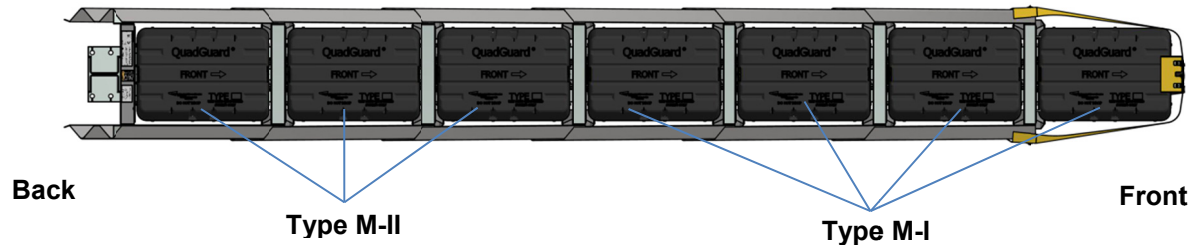

**Figure 11 Plans & Elevation**

**Key**

- 1) Backup
- 2) Quad-Beam™ Fender Panel
- 3) Nose Cover
- 4) Cartridge
- 5) Diaphragm
- 6) Monorail

## How to Determine Left/Right

To determine left from right when ordering parts, stand in front of the system facing the roadside obstacle. Your left is the system's left and your right is the system's right.

## Counting the Number of Bays

One Bay consists of one Cartridge, one Diaphragm, and two Fender Panels. The Nose section is not considered a Bay, though there is a Cartridge in the Nose of each system.

**Note:** There will always be one more Cartridge in the system than the number of Bays in the system. To determine number of Bays, count Fender Panels on one side (Figure 12).

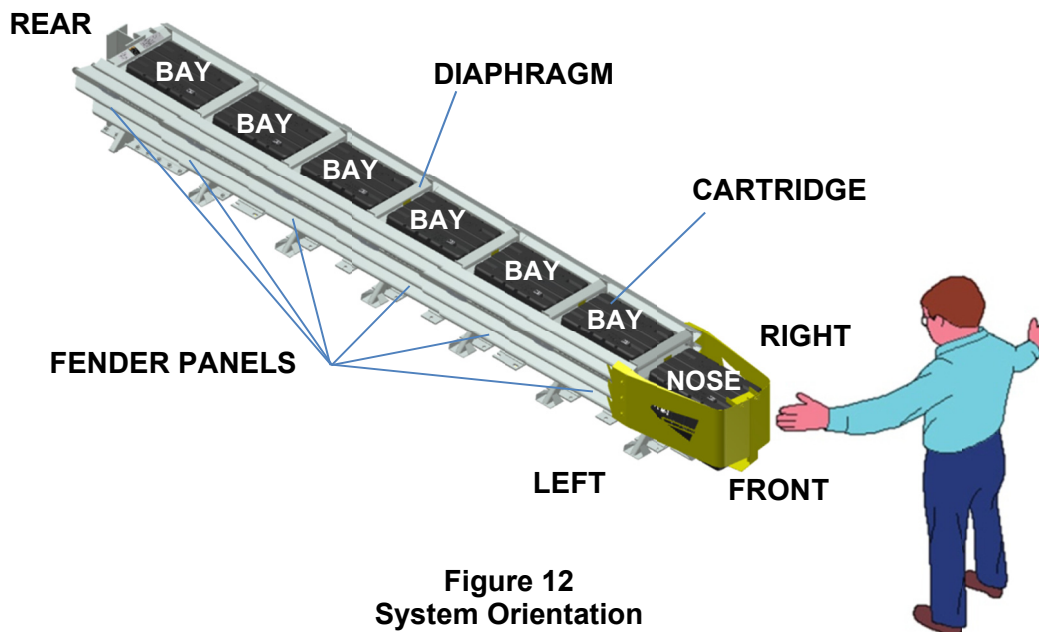

**Figure 12**  
**System Orientation**

## Measuring the Width

The nominal width of the 24" parallel system is the width of the diaphragm (Figure 13).

The outside width of the system is approximately 150 mm [6"] wider than the nominal width.

**Note:** The outside width of the system is not the same as the width of the Backup.

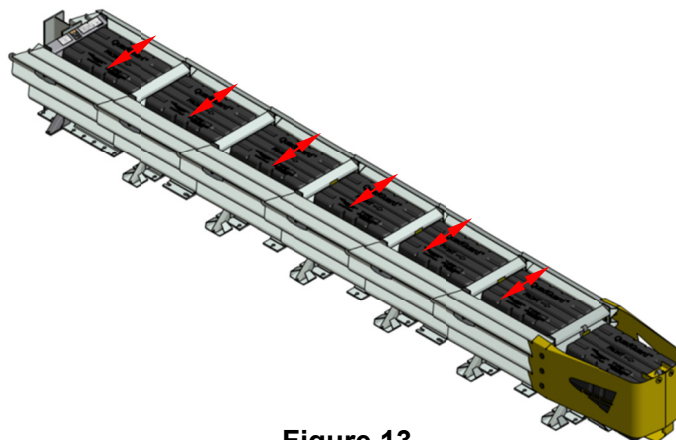

**Figure 13**  
**Width of Parallel system**

## System Assembly



**Warning:** Ensure that your assembly procedure meets all appropriate Occupational Safety and Health Administration (OSHA) and local standards.

### 1) Mark System Location

Locate the centerline of the system by measuring the proper offset from the fixed object. Refer to the Drawing Package supplied with the system. Place chalk line to mark the centerline of the system. Mark a construction line parallel to the center line and offset 165 mm [6.5"] to one side as shown in Figure 14. The edge of the Monorail will be positioned on this line.

**Note:** The concrete foundation must comply with the Manufacturer's Drawing Package supplied with the system.



**Warning:** Location of system with respect to the roadside obstacle is critical and dependent on the type of Transition Panel used. Please refer to the Drawing Package supplied with the system for details.



**Figure 14**  
(Top view of concrete foundation)

### 2) Anchor the Backup

#### A) Concrete Backup (Figure 15)

Locate Backup Face Plate using the Backup Assembly drawing. Verify that any applicable Transition Panels fit properly before anchoring the Face Plate. Drill anchor boreholes in the Concrete Backup using the Face Plate as a template. Anchor the Face Plate to the Concrete Backup using an approved adhesive supplied with the QuadGuard<sup>®</sup> M10 system (p. 17).



**Warning:** Every hole in the Backup and Monorail must be anchored using an approved adhesive (p. 17).

#### B) Tension Strut Backup (Figure 16)

Locate Tension Strut Backup and Monorail on foundation with side of Monorail on the construction line (p. 25). Verify that any applicable Transition Panels fit properly before anchoring Backup. Drill 22 mm [7/8"] diameter by 145 mm [5 3/4"] anchor boreholes in foundation using the Backup as template. Anchor the Backup to the concrete foundation using an approved adhesive supplied with the QuadGuard M10 system (p. 17).



**Caution:** Every hole in the Backup and Monorail must be anchored by a stud using an approved adhesive (p. 17).

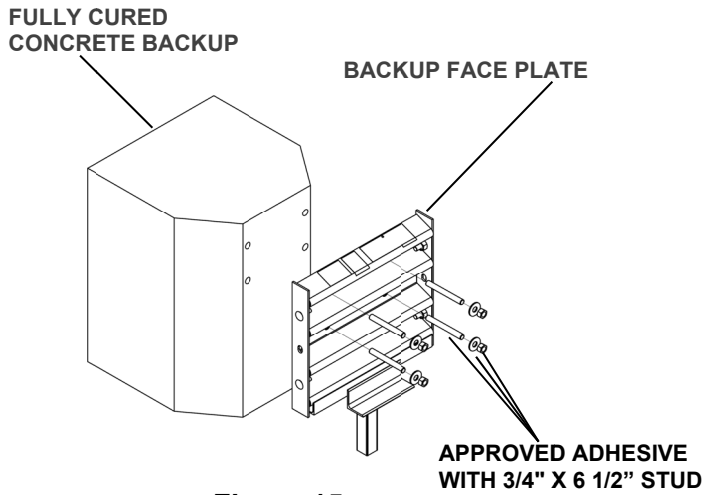

**Figure 15**  
Anchoring Backup Face Plate to Concrete Backup

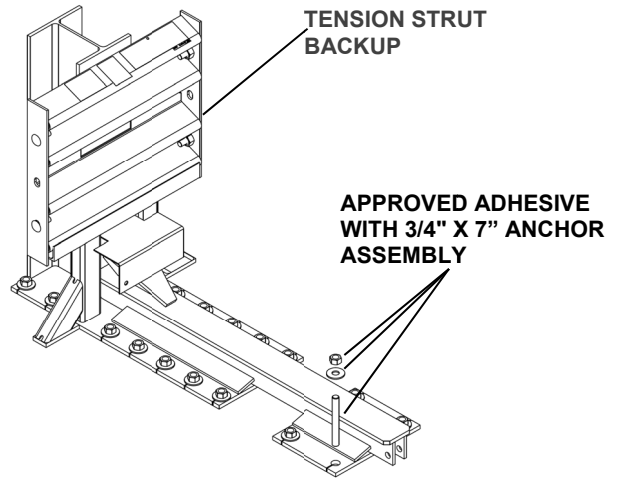

**Figure 16**  
Anchoring Tension Strut Backup to Foundation

### 3) Anchor the Monorail

#### A) Monorail Placement for Concrete Backup (Figure 19)

Locate Monorail on foundation with side of Monorail on the construction line and rear edge of Monorail foot 10" forward of front face of Concrete Backup.

Orient the Monorail so that the Monorail tongues face Backup.



**Warning:** Improper alignment of the Monorail Sections may prevent proper system collapse during impact (Detail A).

It is important to align each segment of Monorail from the back to the front of the system ( $\pm 6$  mm [ $1/4$ "]). Anchor each Monorail section using the provided Trinity Highway approved adhesive kit.

Drill 22 mm [ $7/8$ "] diameter by 145 mm [ $5 3/4$ "] boreholes using the Monorail as a template. Do not drill through foundation.

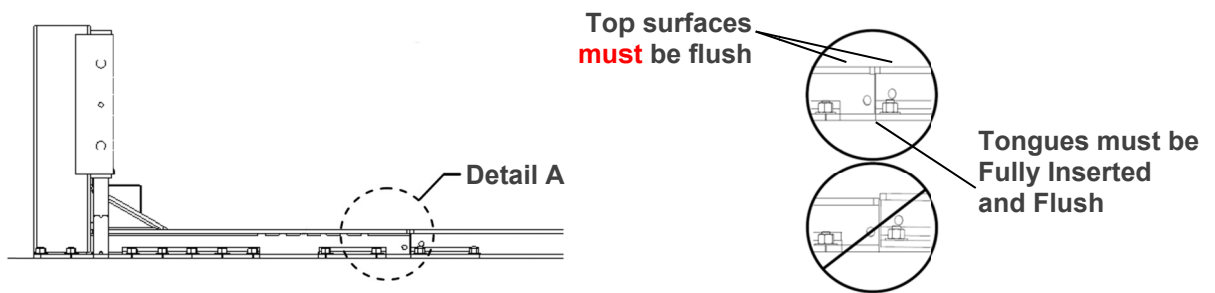

**Figure 17**  
Rail Height and Alignment

**Detail A**



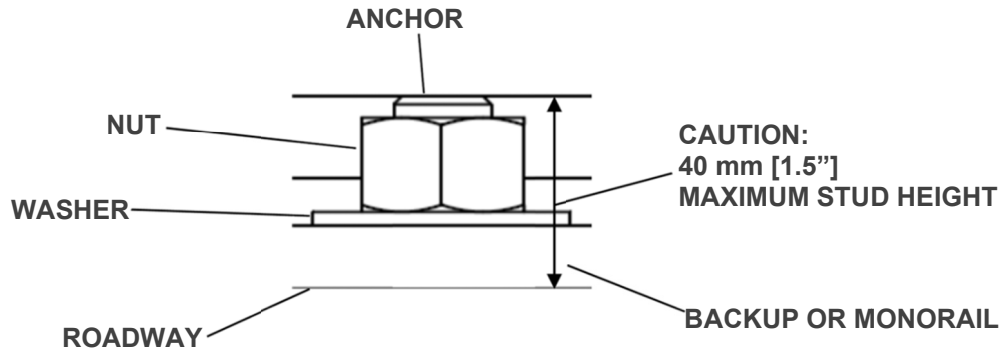

**Figure 18**  
**Final Stud Height**  
**(After Applied Torque)**

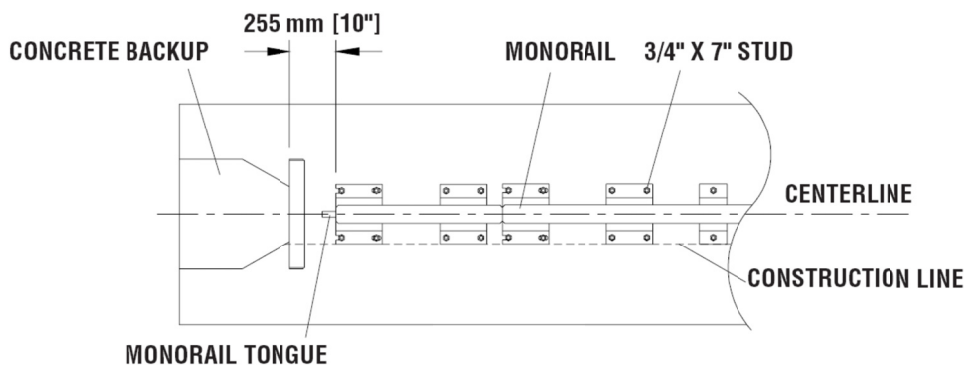

**Figure 19**  
**Monorail Location for Concrete Backup**

**B) Monorail Placement for Tension Strut Backup (Figure 20)**

Locate Monorail on foundation with side of Monorail on the construction line and rear edge of Backup foot 4" forward of edge of foundation.

Orient the Monorail so that the Monorail tongues face the Backup.



**Warning:** Improper alignment at the Monorail splice joints may prevent proper system collapse during an impact (p. 23).

It is important to align each segment of Monorail from the back to the front of the system ( $\pm 6$  mm [ $1/4$ "]). Anchor each Monorail section using the Trinity Highway approved adhesive kits provided (p 13).



**Warning:** Every hole in the Backup and Monorail must be anchored by a stud using an approved adhesive (p. 17).

Drill 22 mm [ $7/8$ "] diameter by 145 mm [ $5 3/4$ "] boreholes using the Monorail as a template. Do not drill through foundation.

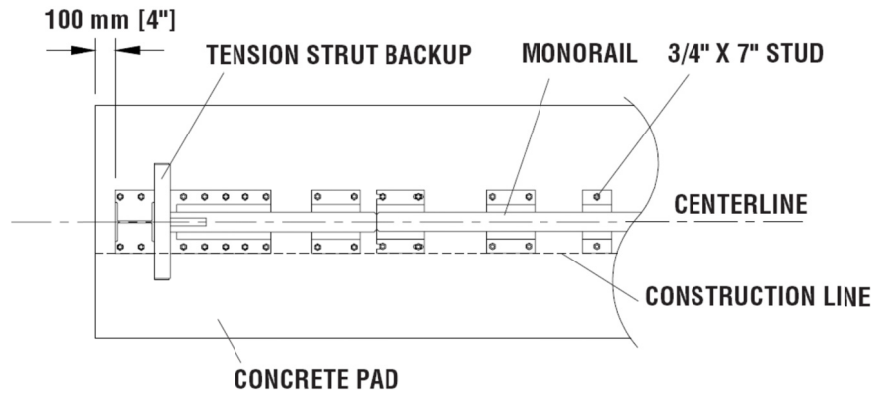

**Figure 20**  
**Backup and Monorail Location for Tension Strut Backup**

**4) Attach Side Panels and/or Transition Panels to Backup Assembly**

Attach Transition Panel or Side Panel to side of Backup using 5/8" rail bolt and 5/8" rail nut (two places - top and bottom holes only\*). See Backup Assembly drawing(s) below.

**Note:** Do not use a Side Panel when a Transition Panel is used.

**Assembly tip:**

Use drift pin to align the center hole of the Side Panel with the center hole of the Backup before inserting the Rail Bolts.

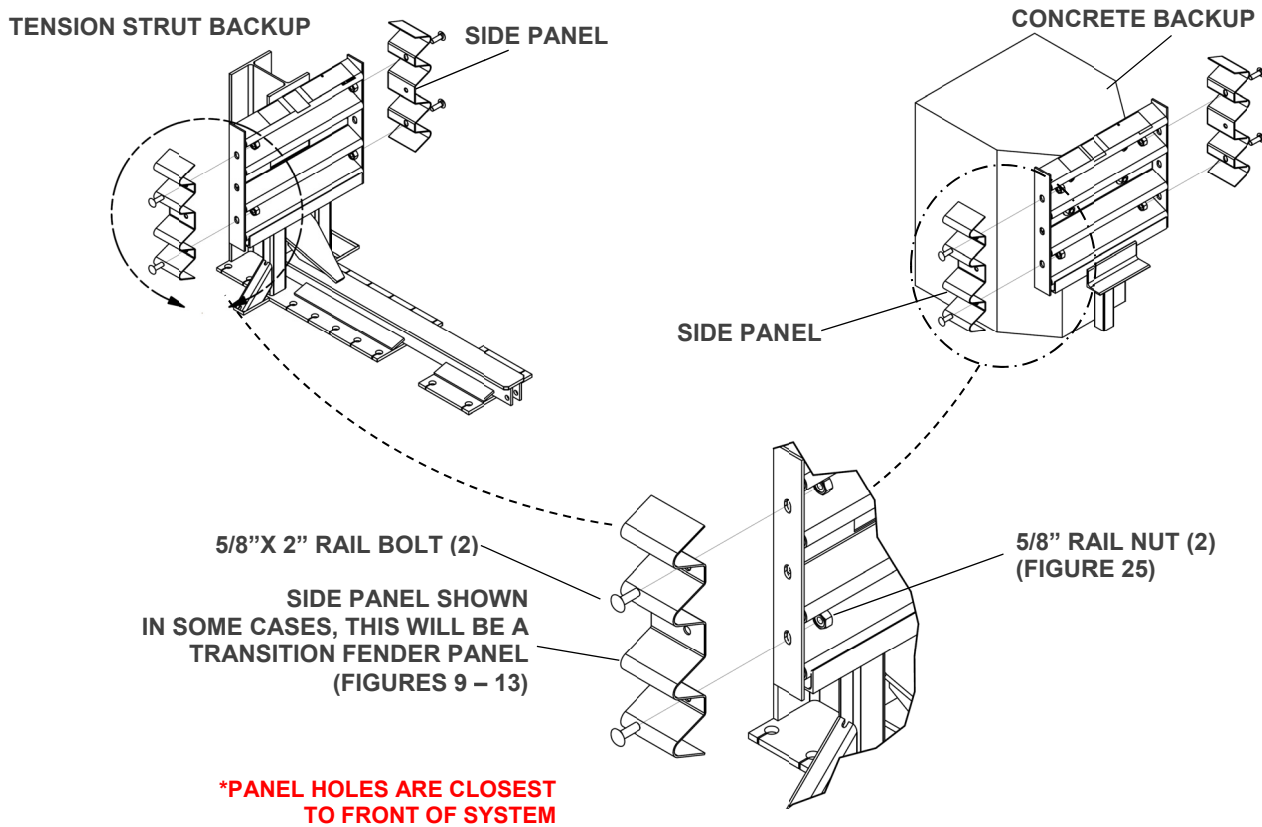

**Figure 21**  
**Side Panel/Transition Panel Attachment**

## 5) Attach Monorail Guides

Attach Monorail guides to Diaphragm as follows:

Insert 3/4" x 2" G8 hex bolt through Monorail guide and Diaphragm with a shim placed between them and oriented as shown in Figure 22. Secure with 3/4" lock washer and 3/4" hex nut (typical 4 places). See the Diaphragm Assembly drawing supplied with the system.

Repeat process for each Diaphragm.

## 6) Attach Diaphragms

Orient a Diaphragm so that the front face of the Diaphragm shape faces toward the Nose of the system as shown in Figure 23.



**Important:** Slide one Diaphragm all the way to the Backup to ensure the system is able to collapse properly during impact.

Orient and slide all other Diaphragms onto Monorail and position each approximately as shown in Figure 24.

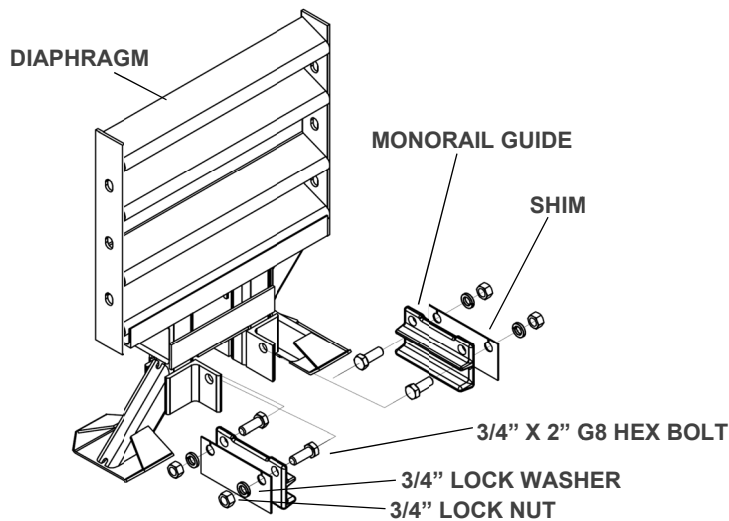

**Figure 22**  
Monorail Guide Attachment

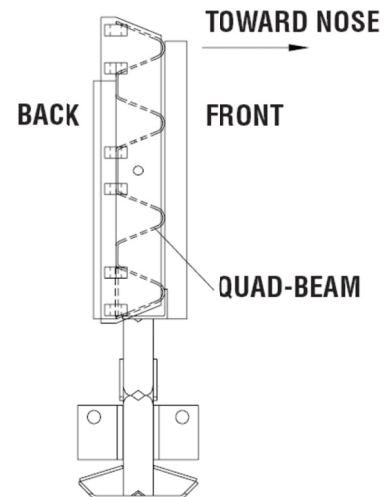

**Figure 23**  
Diaphragm Orientation

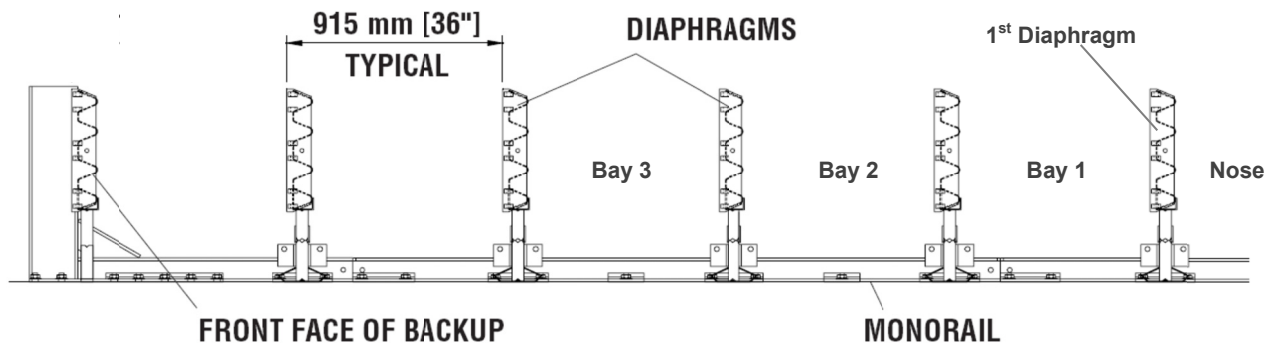

**Figure 24**  
Diaphragm Spacing

## 7) Attach Fender Panels

**Note:** Do not mix the 5/8" rail nuts (large) with the 5/8" hex nuts (small) (Figure 25).

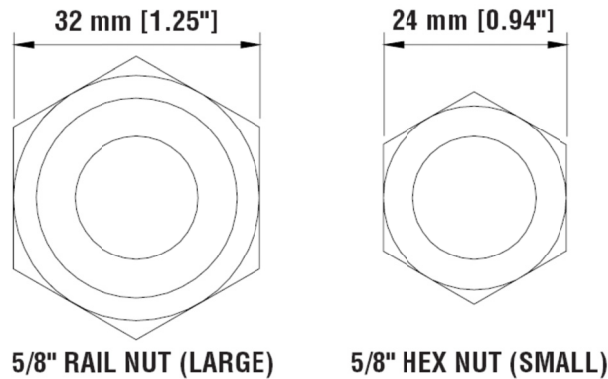

**Figure 25**  
**Rail Nuts are Oversize**

**Note:** Starting at the Backup, attach left and right Fender Panels shown below in Step(s) 4 & 5 with each tapered end pointing toward the rear of the system (p. 28).

### Step 1

Place the Fender Panel so that the center of the slot of the rearward Diaphragm is lined up with the approximate center of the slot in the Fender Panel.

Attach Mushroom Washer Assembly as shown in Figure 26, Detail 26a, and 26b. Do not torque fasteners at this time. This (Step 1) helps to balance the Fender Panel.

### Step 2

Slide the Fender Panel forward until the holes in the Fender Panel line up with the holes in the forward Diaphragm.

### Step 3

Use a drift pin to align the center hole of the Fender Panel with the center hole of the Diaphragm.

**Note:** Working from the Backup, assemble and tighten one Bay section at a time toward the Nose of the system.

**Step 4**

Attach the front of the Fender Panels to the next Diaphragm using two (2) rail bolts and large hex nuts per side. Use only the top and bottom holes and leave the center hole open until the next Fender Panel is attached.

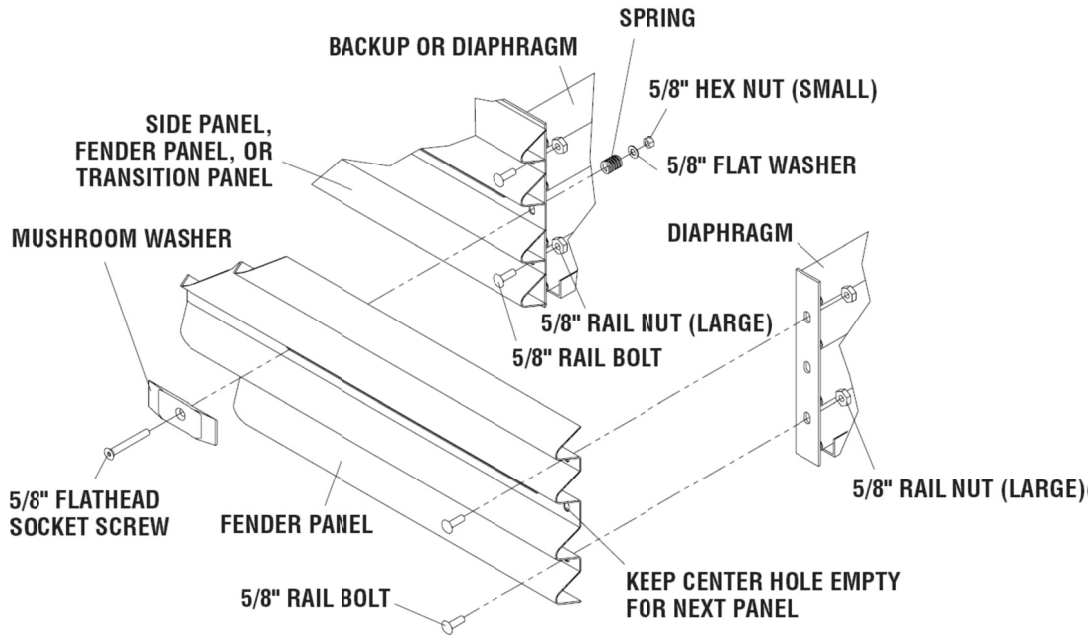

**Figure 26  
Fender Panel Assembly**

**Step 5**

Be sure Mushroom Washer lays flat against the Fender Panel as shown in Detail 26b. Standoff on Mushroom Washer must be seated completely through slot.

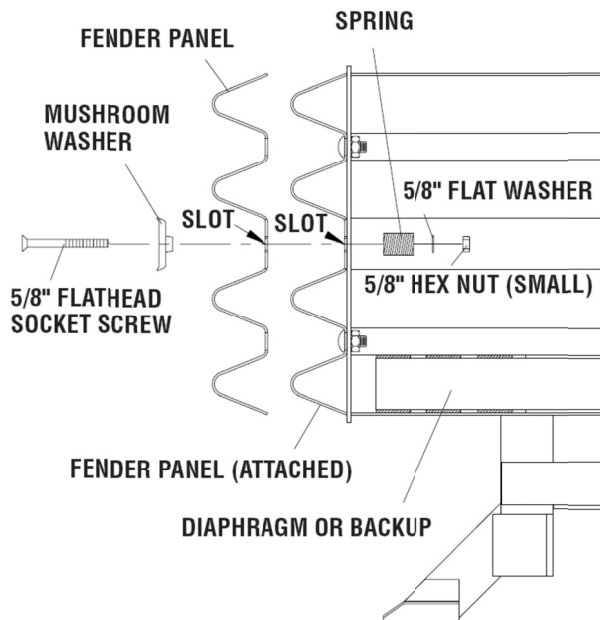

**Detail 26a  
Mushroom Washer Attachment**

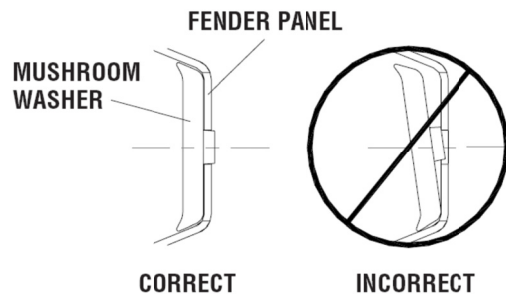

**Detail 26b  
Mushroom Washer Orientation**



**Important:** Starting from the Backup, attach and tighten each Bay section one at a time.

**Step 6**

Check Diaphragm spacing to ensure 915 mm [36"] between rear faces of consecutive Diaphragms, as shown in Figure 27 and Fender Panel assembly drawing.

**Step 7**

Once proper spacing has been achieved, tighten the Mushroom Washer Assembly (small hex) nut until it reaches the end of the threads.

Assemble the remaining Diaphragms and Fender Panels following the same procedures.

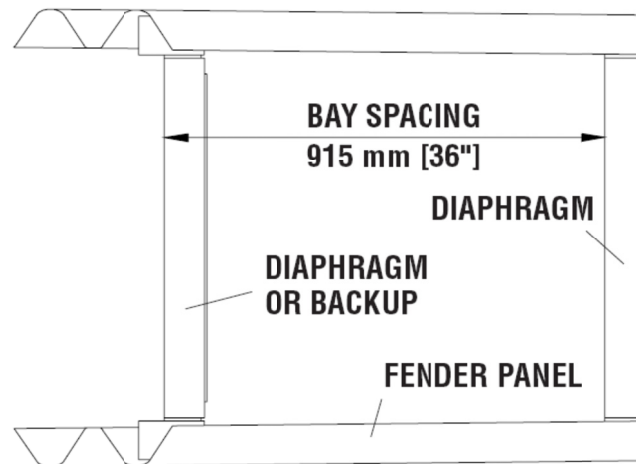

**Figure 27**  
**Proper Diaphragm Spacing**

**8) Attach End Cap**

Attach the End Cap to the front of the first Monorail segment, as shown below and the Monorail Assembly drawing.

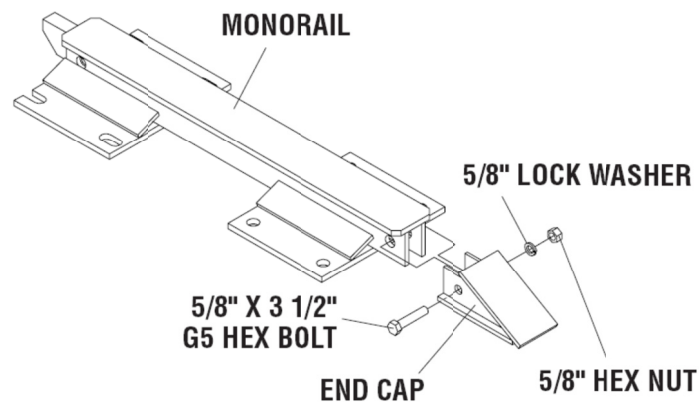

**Figure 28**  
**Monorail End Cap Attachment**

**9) Attach Lower Cartridge Support Brackets**

Attach lower Cartridge Support Bracket to the front and back of all Diaphragms and also to the front of the Backup as shown below.

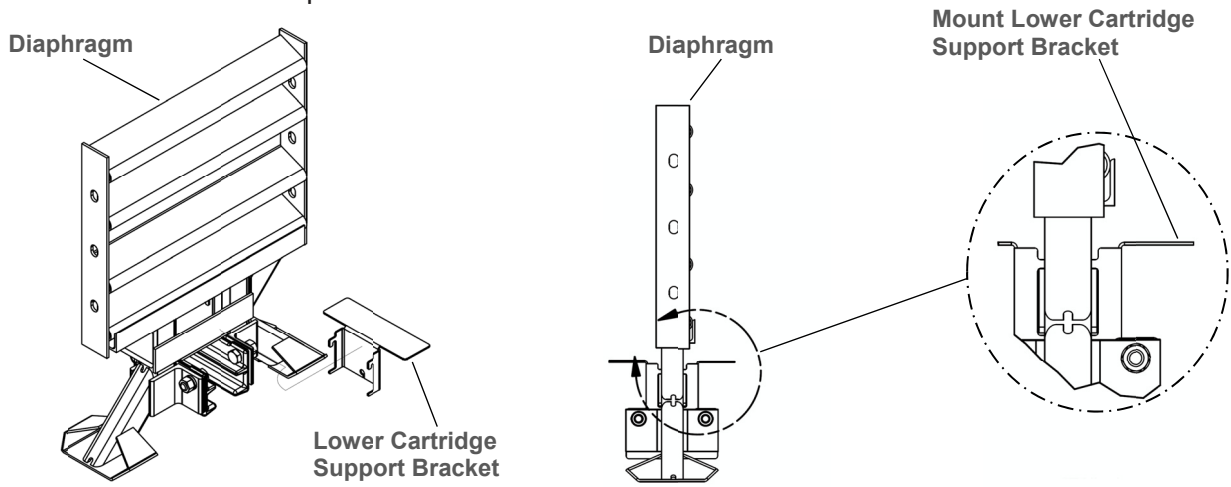

**Figure 29  
Lower Cartridge Support Bracket Assembly**

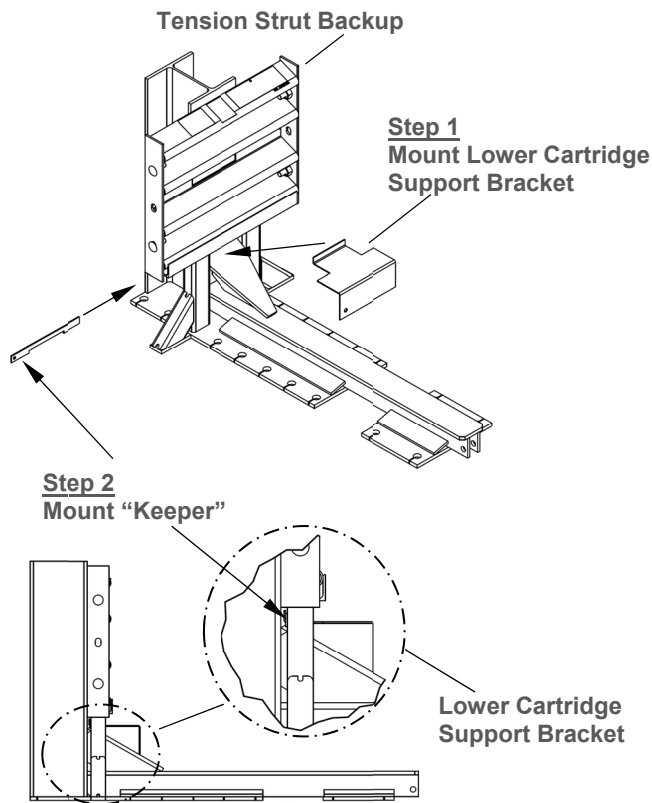

**Figure 30  
Lower Cartridge Support Bracket Assembly  
(Tension Strut Backup)**

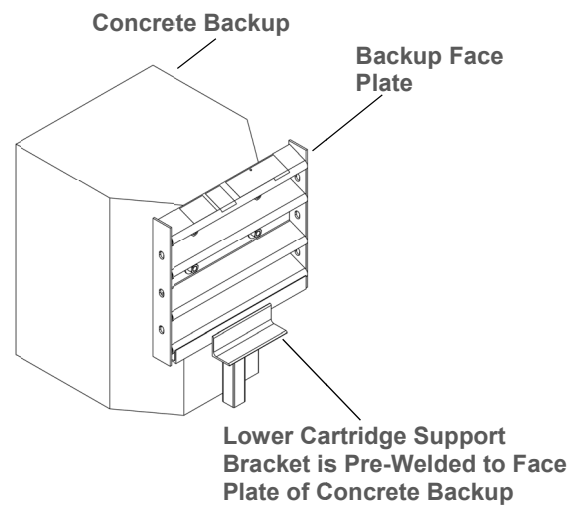

**Figure 31  
Lower Cartridge Support Bracket  
(Concrete Backup)**

## 10) Nose Assembly

Bolt the Nose directly to the front Diaphragm, as shown in Figures 32a through 32d and the Nose Assembly drawing.

Place Pullout Brackets under center bolts as shown in Detail 32d.

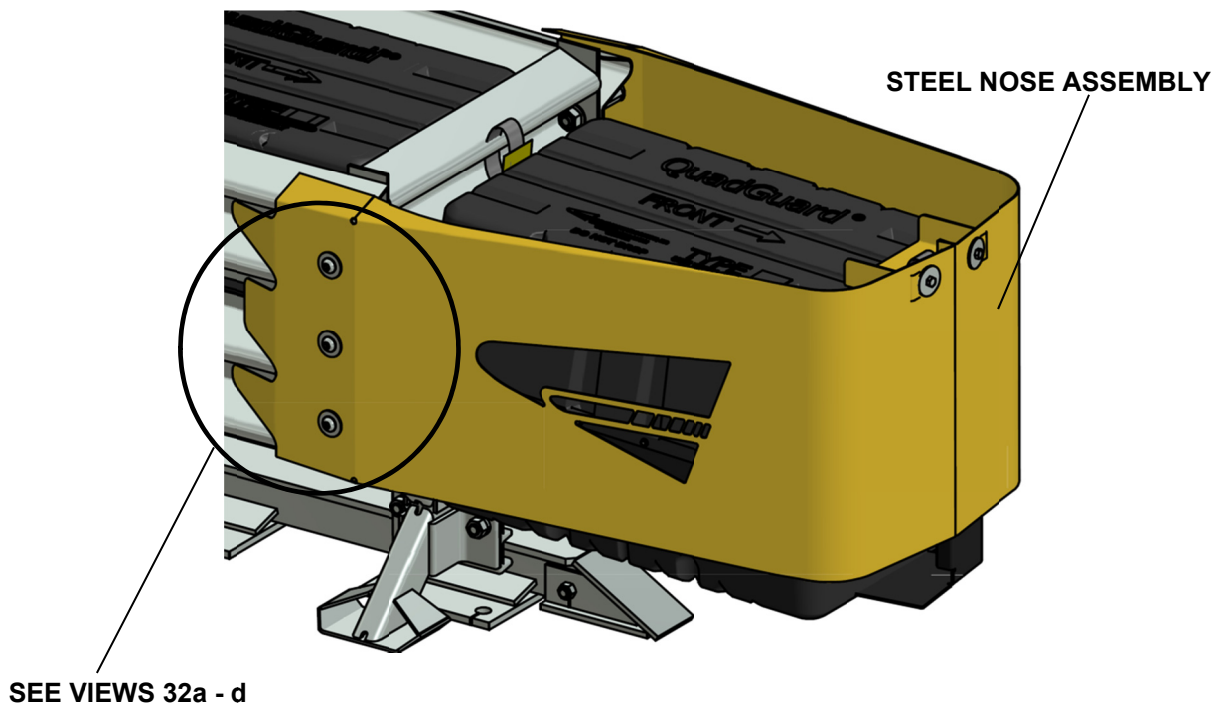
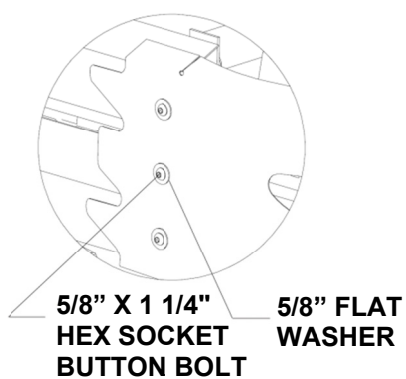
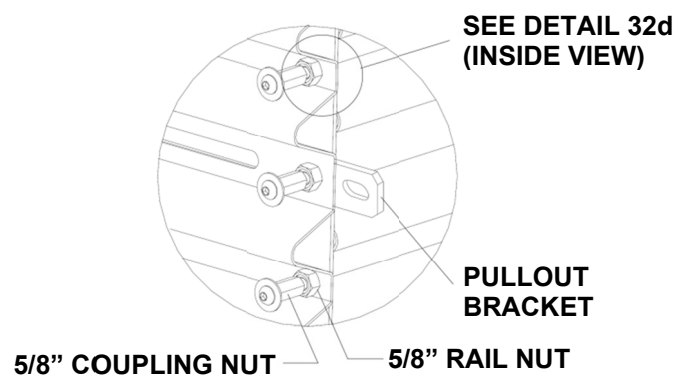

Figure 32



Detail 32a  
Fastener Assembly



Detail 32b  
Steel Nose not shown for clarity



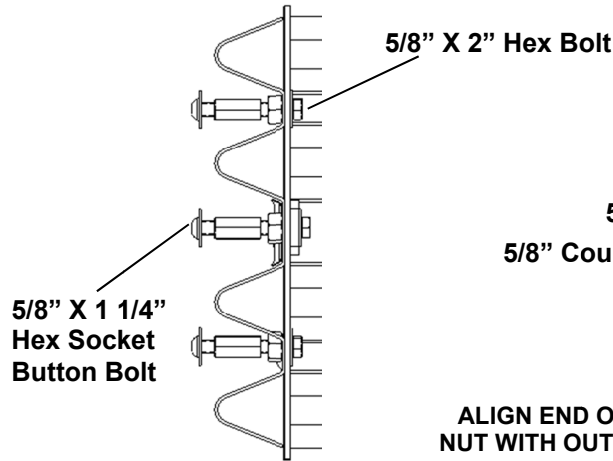

**Detail 32c**  
End View: Nose Cover Removed

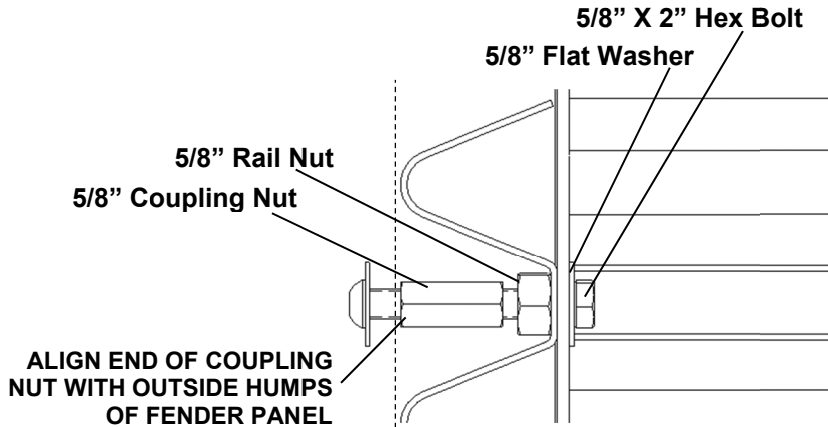

**Detail 32d**  
Inside View: Nose Cover Cut Away

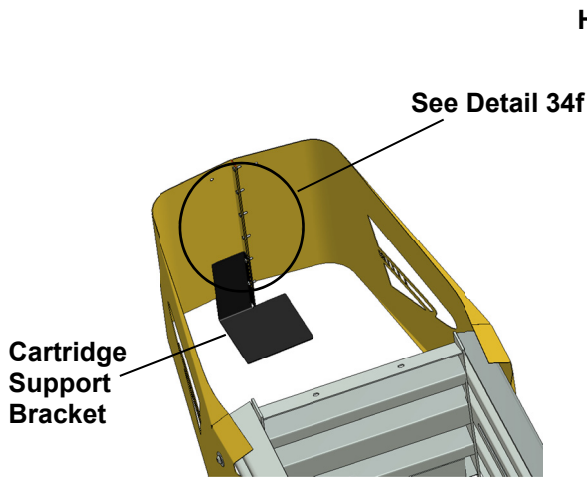

**Detail 32e**

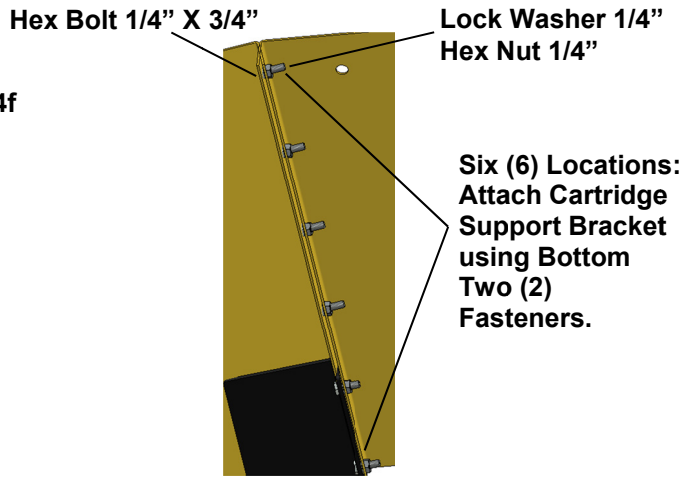

**Detail 32f**

Detail 34e shows proper placement of front Cartridge Support Bracket.

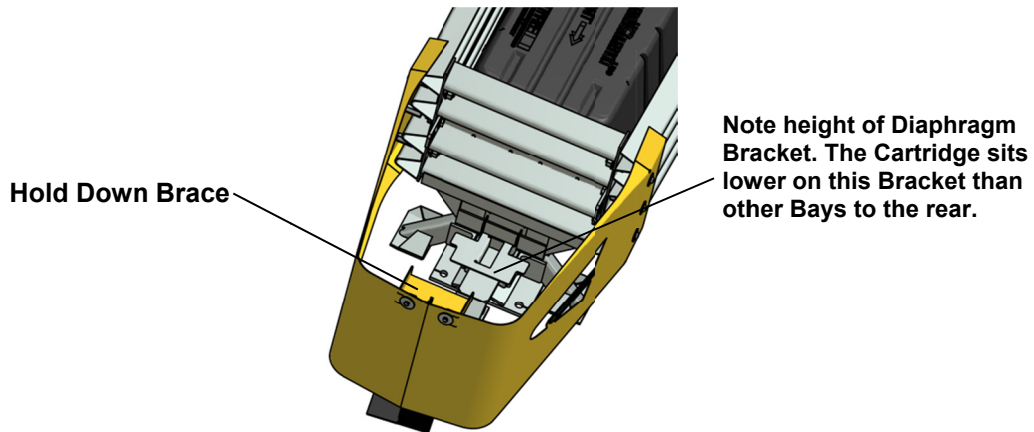

**Detail 32g**

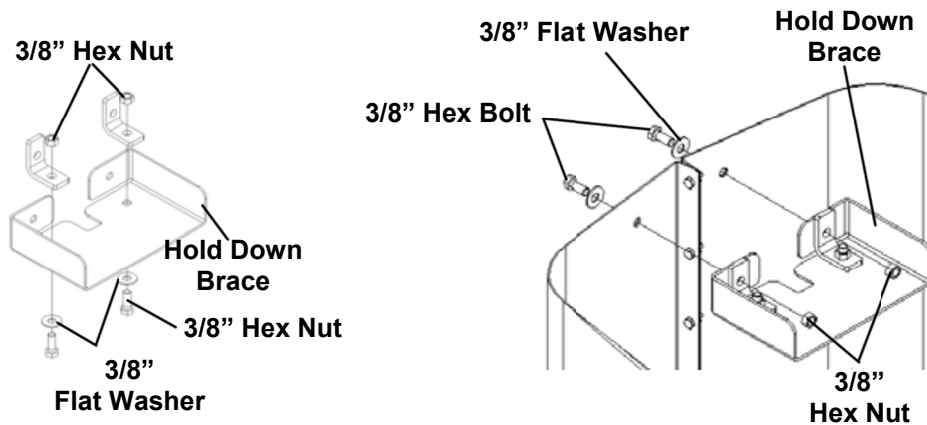

**Figure 33**  
**Hold Down Brace Assembly**

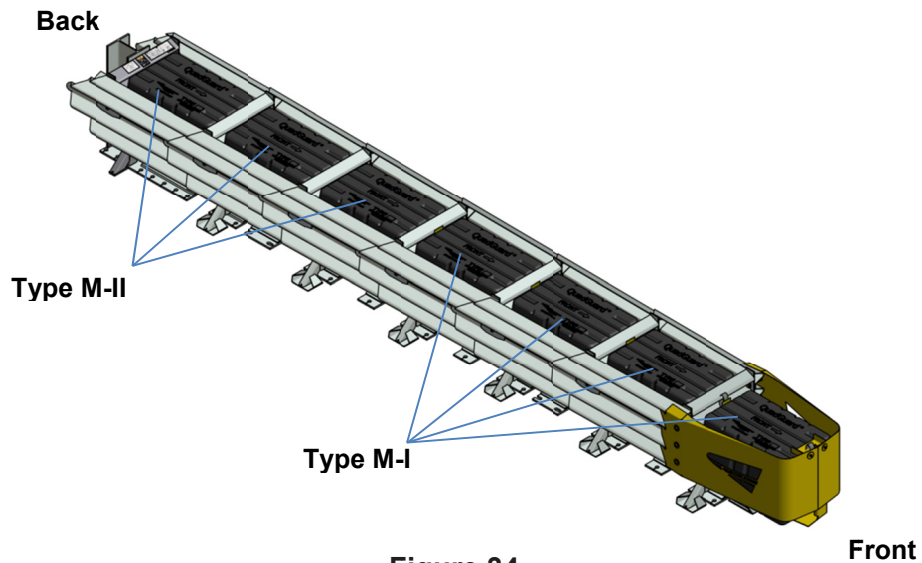

**Figure 34**  
**Cartridge Layout**

**11) Checking the System Assembly**

At this point recheck to ensure that all fasteners are properly tightened throughout the system (anchor bolts, etc.). See torque requirements below. Check all Fender Panels. If they do not fit tightly against the underlying Panel, system realignment may be necessary (Figure 35).



<b>Warning</b>	
Bolt Torque Requirements	
Anchor Studs – Table A, p. 17	
Critical Clearances	
Anchor Studs above nuts – Figure 18, p. 24	
Fender Panel Gap – 20 mm [0.78"] p. 34	

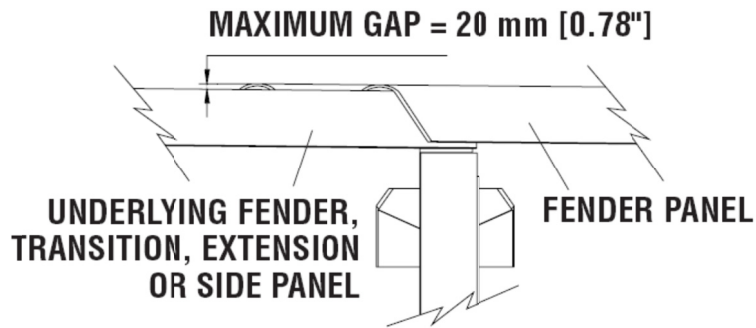

**Figure 35**  
**Fender Panel Gap**

## 12) Cartridge Placement

The top surface of the Nose Cartridge should be horizontal. To complete the assembly of a QuadGuard<sup>®</sup> M10 system, place the appropriate Cartridge in each Bay and Nose section of the system. Type M-I Cartridges are placed toward the front (Nose) of the system; Type M-II Cartridges are placed toward the rear (Backup) of the system (p. 33).



**Warning:** Placing the wrong Cartridge in the Nose or any Bay may result in unacceptable crash performance as described in MASH.



**Important:** The QuadGuard<sup>®</sup> M10 is a Six Bay configuration.

## **Final Inspection Checklist**

**Date:** \_\_\_\_\_

**Inspector:** \_\_\_\_\_

- Clearance of 30" behind rear Fender Panels for slide back
- Transition Panel fits for the offset
- Every hole and slot in Backup and Monorail is anchored
- Anchor stud(s) are almost flush with nut(s) (1.5" from the pad)
- If no transition, check for narrow side panels at backup
- Diaphragms attached to the Monorail guides
- Mushroom Washers lay flat in slots
- Each Fender Panel has a tension Spring
- Monorail has End Cap attached
- Cartridges are level and the same height in each Bay
- Nose Cartridge is level
- Fender Panel gap is 20 mm (0.78") for Narrow systems
- Cartridge types are properly placed
- Bolts and nuts are tightened
- Anchors are properly torqued
- Diaphragm Shims aligned and in place
- Cartridge Hold Down Bracket is secure and engaged with Nose Cartridge

## **Maintenance and Repair**

### **Inspection Frequency**

Inspections for QuadGuard® M10 systems are recommended as needed based upon volume of traffic and impact history. Visual Drive-By Inspections are recommended at least once a month. Walk-Up Inspections are recommended at least once a year.

### **Visual Drive-By Inspection**

- 1) Check to see if there is evidence of an impact. If so, perform a walk-up inspection.
- 2) Check to see if the Cartridges are properly seated on the Support Brackets. Any damaged Cartridges must be replaced.



**Warning:** See Cartridge placement instructions on page 34.

- 3) Be sure the Steel Nose is in place.
- 4) Note the location and condition of the QuadGuard® M10 system and the date of visual drive-by inspection.

### **Walk-Up Inspection Checklist**

- Clear and dispose of any debris on the site.
- Clear and remove excessive dirt from around the Monorail and Diaphragm feet.
- Bolts are tight and rust free.
- Anchor bolts are securely anchored.
- Ensure Diaphragm Legs are straight.
- All Mushroom Washer Assemblies are properly seated.
- Fender Panels and Transition Panels should nest tightly against the system.
- Be sure Cartridges have not been damaged and are properly seated on their Support Brackets. To ensure intended speed characteristics, partially crushed Cartridges (due to low speed impacts) must be replaced.
- Make all necessary repairs as described above. See Post-Impact Instructions for more information on next page.
- To determine if a product should be replaced or is potentially reusable, a trained engineer experienced in highway products and directed by the DOT, or other appropriate local highway authority, must be consulted.

## Post-Impact Instructions



**Important:** Trinity Highway makes no recommendation whether use or reuse of any part of the system is appropriate or acceptable following an impact. It is the sole responsibility of the local highway authority and its engineers to make that determination. It is critical that you inspect this product after assembly is complete to make certain that the instructions provided in this manual have been strictly followed.

- 1) Deploy appropriate traffic-control devices.
- 2) Check to see that all anchor bolts have remained firmly anchored in the roadway surface. Replace any that are loose, broken, or pulled out.

**The proper performance of the system during an angle impact depends on the Monorail anchors being properly anchored.**

- 3) Clear and dispose of any debris on the site.
- 4) Check the system to be certain that the Mushroom Washer Assemblies holding the Fender Panels together are still intact and that the system has not been deformed in a way that would prevent pulling it back to its original position.
- 5) Be sure that the Diaphragm Support Legs are all properly attached to the Monorail.



**Caution:** Use eye protection and gloves when refurbishing the Mushroom Spring Assembly. Do not place fingers underneath an assembled Mushroom Washer. Parts may suddenly shift and fingers may be pinched. If the spring is still under compression as the nut is nearing the end of the bolt, to prevent injury make sure that the spring is restrained with a clamp so it does not suddenly release when nut is removed from the Mushroom Washer Bolt.

- 6) Attach chain to Pullout Brackets on first Diaphragm (Figure 36). Attach both ends of chain to a heavy vehicle (such as a 1 ton pickup).



**Warning:** Stand clear in case chain breaks or becomes disconnected.

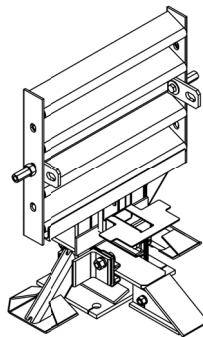

**Figure 36**  
**Pullout Brackets**

Slowly pull the QuadGuard® M10 system forward until the system reaches its original length. Have someone watch the system during repositioning to be certain previously undetected damage does not cause the Diaphragms to bind or pull out improperly.

- 7) Remove all crushed Cartridges from within the system.
- 8) Check to see that the Diaphragms are in usable condition. Diaphragms which are bowed or have bent legs must be replaced.
- 9) Check that the Fender Panels are properly attached with the Mushroom Washer Assemblies. Damaged Fender Panels and Transition Panels must be replaced.



Warning	
Fender Panel	Maximum gap allowed:
<b>24" Wide Systems</b>	<b>20 mm [0.78"]</b>

- 10) Check the **gaps between Fender Panels**. The maximum gap allowed for these overlapping parts (including Fender Panels overlapping Panels behind the system) is 20 mm [.78"].



**Important:** Ensure the Mushroom Washer Assemblies are torqued to the end of the threads. If the gaps between the Fender Panels are still too large, it may be necessary to replace bent parts.

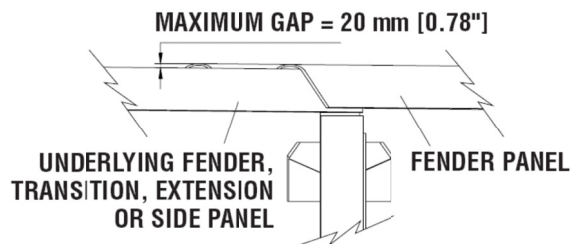

**Figure 37**  
**Fender Panel Gap**

- 11) Replace all crushed Cartridges and damaged Cartridge Support Brackets. See Cartridge Placement on page 34.
- 12) Remove damaged Nose Assembly. Attach the new Nose to the first Diaphragm, using the six (6) threaded rods and four (4) rail nuts per rod. See pages 31 - 33 for Nose attachment instructions.



Warning	
<b>Bolt Torque Requirements</b>	
Anchor Studs –Table A, p. 17	
<b>Critical Clearances</b>	
Anchor Studs above nuts – p. 24	
<b>Fender Panel Gap– 20 mm [0.78"]</b>	

- 13) Check all bolts on the system to ensure they are adequately tight.
- 14) Check to be certain that the site is free from any debris. The QuadGuard® M10 system is now ready for use.

## Parts Ordering Procedure

Make a list of all damaged parts from the System Components section in this manual (p. 7 – 10). Answer the following questions in the spaces provided. This information is necessary to receive the proper parts.

<b>Table B</b>		
<b>QuadGuard® M10 System Ordering Information Chart</b>		
<b>Description:</b>	<b>Choices</b>	<b>Fill in this section</b>
<b>Type of Backup?</b>  See Figures 1 or 2 on page 11.	<ul style="list-style-type: none"> <li>• Concrete</li> <li>• Tension Strut</li> </ul>	
<b>Transition Panel Type?</b>  Side Panel and Transition Panel Types are on page 12. Include Transitions for both sides if necessary. How to Determine Left/Right is on page 21.	<ul style="list-style-type: none"> <li>• Quad to W</li> <li>• Quad to Thrie</li> <li>• Quad to Safety Shape Barrier</li> <li>• Quad to End Shoe</li> <li>• 4" Offset Panel</li> <li>• None</li> </ul>	

## Parts List(s) & Quantities

PN	Description	Tension Strut Backup		Concrete Backup	
		Concrete	Asphalt	Concrete	Asphalt
003300	5/8X1 3/4 Flat Washer	24	24	24	24
003340	5/8 Rail Nut	35	35	35	35
003400	5/8X2 Rail Bolt	28	28	28	28
003704	3/4 Heavy Hex Nut	76	76	70	70
113404	5/8X1 1/4 Button Head Screw	6	6	6	6
113518	1/4X3/4 Hex Bolt, G5	6	6	6	6
113555	3/4X2 Hex Bolt, G8	24	24	24	24
113596	3/8X1 Hex Bolt, G5	4	4	4	4
113660	5/8X3 1/25 Hex Bolt, G5	1	1	1	1
115946	1/4 Hex Nut	6	6	6	6
115960	3/8 Hex Nut	4	4	4	4
115970	5/8 Hex Nut	12	12	12	12
115986	5/8X2 1/8 Coupling Nut	6	6	6	6
116799	3/4X18 G5 Stud	0	52	0	42
116878	5/8X5 Socket Head Screw	12	12	12	12
117459	1 1/4X1 1/2 Die Spring	12	12	12	12
117540	3/4X6 1/2 G5 Stud	0	0	4	4
117542	3/4X7 G5 Stud	52	0	42	0
118027	3/4X2 Flat Washer	52	52	46	46
118036	3/8 Flat Washer	2	2	2	2



PN	Description	Tension Strut Backup		Concrete Backup	
		Concrete	Asphalt	Concrete	Asphalt
118038	3/8X2 Flat Washer	2	2	2	2
118085	1/4 Lock Washer	6	6	6	6
118089	3/4 Lock Washer	24	24	24	24
118100	5/8 Lock Washer	1	1	1	1
118232	5/8X2 1/2 Hex Bolt	2	2	2	2
118570	5/8X2 Hex Bolt, G5	4	4	4	4
118710	Hilti HY200 Adhesive	13	13	12	12
604663	Concrete Backup, 24"	0	0	1	1
605430	Nose Cartridge Bracket	1	1	1	1
605446	Cartridge Support Bracket	11	11	11	11
605447	TS Cartridge Support Bracket	1	1	1	1
605535	Pullout Bracket	2	2	2	2
607821	Diaphragm, 24"	6	6	6	6
608136	Monorail End Cap	1	1	1	1
611266	Locking Bar	1	1	1	1
611368	Monorail Guide	12	12	12	12
611370	One Bay Monorail	0	0	1	1
611375	Two Bay Monorail	1	1	1	1
611379	Three Bay Monorail	1	1	1	1
611669	Left Nose	1	1	1	1
611680	Right Nose	1	1	1	1
611832	Fender Panel	12	12	12	12
611898	Side Panel	2	2	2	2
614062	Monorail Shim	12	12	12	12
617045	Mushroom Washer	12	12	12	12
617383	Nose Cart. Support Bracket	1	1	1	1
617384	M10 Hold Down Bracket	1	1	1	1
617387	Angle Brackets	2	2	2	2
617412	Type M-I Cartridge	4	4	4	4
617414	Type M-II Cartridge	3	3	3	3
626055	Tension Strut Backup, 24"	1	1	0	0



**Warning:** Use only Trinity Highway parts that are specified herein for the QuadGuard® M10 for assembling, maintaining, or repairing the QuadGuard® M10 system. **Do not utilize or otherwise comingle parts from other systems even if those systems are other Trinity Highway systems.** Such configurations have not been tested, nor have they been deemed eligible for use. Assembly, maintenance, or repairs using unspecified parts or accessories is strictly prohibited.



# QGMCBCVR-U

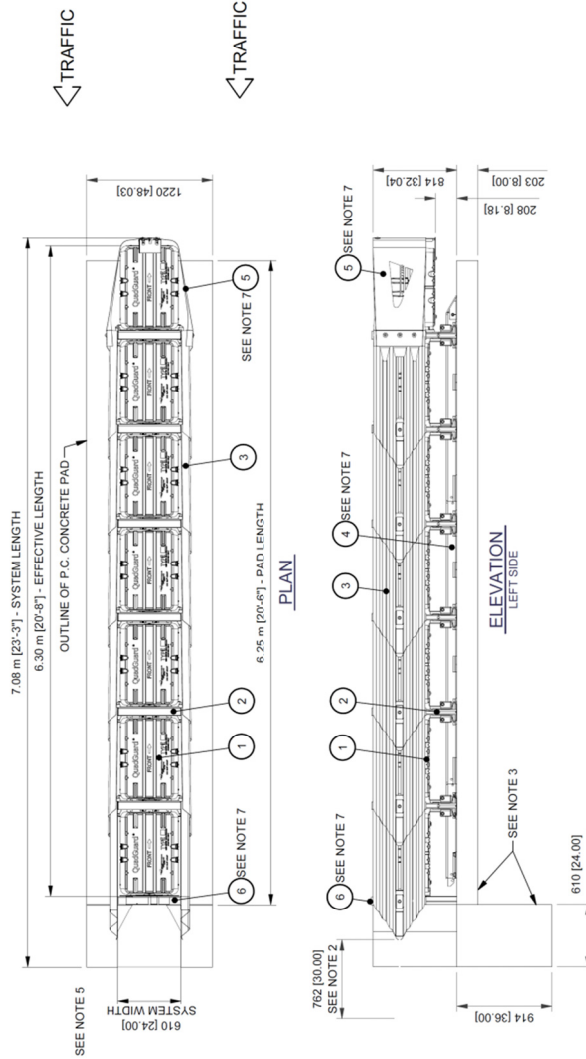

- NOTES:
1. IN COMPLIANCE WITH THE AASHTO 2011 ROADSIDE DESIGN GUIDE, MANUFACTURER RECOMMENDS REMOVAL OF ALL CURBS AND ISLANDS TO ENSURE PROPER IMPACT PERFORMANCE.
  2. PROVISION SHALL BE MADE FOR REAR FENDER PANELS TO SLIDE REARWARD UPON IMPACT.
  3. 150 (6.00) MIN. REINFORCED 28 MPa (4000 PSI) P.C. CONCRETE PAD OR 200 (8.00) MIN. NON-REINFORCED 28MPa (4000 PSI) P.C. CONCRETE ROADWAYS MEASURING AT LEAST 8" (203) FROM THE FACE OF THE CONCRETE PAD. CONCRETE SHALL BE INSTALLED AGAINST AN IMMOVABLE STRUCTURE AS A CONCRETE WALL OR ABUTMENT.
  4. SEE THE "QUADGUARD M10 SYSTEM PRODUCT MANUAL" FOR A DESCRIPTION OF ITS IMPACT PERFORMANCE CHARACTERISTICS AND DESIGN LIMITATIONS BEFORE PLACING A SYSTEM AT A GIVEN SITE. INFORMATION AND COPIES OF ABOVE MANUAL ARE AVAILABLE BY CALLING CUSTOMER SERVICE DEPARTMENT AT (888) 323-5374.
  5. WHERE NECESSARY, THE CUSTOMER SHALL SUPPLY AN ADEQUATE TRANSITION FROM THE QUADGUARD M10 SYSTEM TO THE OBJECT BEING SHIELDED.
  6. UNITS OF MEASUREMENT ARE MILLIMETERS (INCHES) UNLESS OTHERWISE NOTED. BACKUP, MONORAIL AND NOSE ASSEMBLIES ARE NOT INCLUDED IN MODEL NUMBER. ORDER SEPARATELY.
  7. BACKUP, MONORAIL AND NOSE ASSEMBLIES ARE NOT INCLUDED IN MODEL NUMBER. ORDER SEPARATELY.
  8. THE QUADGUARD M10 6-BAY SYSTEM HAS BEEN TESTED TO MASH TEST LEVEL 3.

BAYS	WIDTH	NO. OF CARTRIDGES
1-2	MODEL #	TYPE MH
6	QM10024	4
		3

KEY		REFERENCES		UNIDIRECTIONAL	
①	QUADGUARD CARTRIDGE	④	MONORAIL	SERIAL NO.	607113
②	DIAPHRAGM	⑤	NOSE ASSEMBLY	SALES ORDER	614050
③	FENDER PANEL			EH PROJECT	11TR02017
				DESIGN SPEED	100 km/h (62 MPH)
				NOSE TYPE	
				NO. OF UNITS	
				DIAPHRAGM ASSY.	607113
				DIAPHRAGM G1MM KIT	614050
				FENDER PANEL ASSY.	608236
				BACKUP ASSY.	626083, 604507
				MONORAIL ASSY.	626082
				CONCRETE PAD	626084
				DATE	11/2/2017
				BY	R. VENZON
				NO. OF UNITS	6
				MODEL #	QM10024
				TYPE	QGMCBCVR-24U 6W
				DO NOT SCALE DRAWING	
				UNITS	MM
				SCALE	AS SHOWN
				PROJECT	11TR02017
				DATE	11/2/2017
				BY	R. VENZON
				NO. OF UNITS	6
				MODEL #	QM10024
				TYPE	QGMCBCVR-24U 6W
				DO NOT SCALE DRAWING	
				UNITS	MM
				SCALE	AS SHOWN
				PROJECT	11TR02017
				DATE	11/2/2017
				BY	R. VENZON
				NO. OF UNITS	6
				MODEL #	QM10024
				TYPE	QGMCBCVR-24U 6W
				DO NOT SCALE DRAWING	
				UNITS	MM
				SCALE	AS SHOWN
				PROJECT	11TR02017
				DATE	11/2/2017
				BY	R. VENZON
				NO. OF UNITS	6
				MODEL #	QM10024
				TYPE	QGMCBCVR-24U 6W
				DO NOT SCALE DRAWING	
				UNITS	MM
				SCALE	AS SHOWN
				PROJECT	11TR02017
				DATE	11/2/2017
				BY	R. VENZON
				NO. OF UNITS	6
				MODEL #	QM10024
				TYPE	QGMCBCVR-24U 6W
				DO NOT SCALE DRAWING	
				UNITS	MM
				SCALE	AS SHOWN
				PROJECT	11TR02017
				DATE	11/2/2017
				BY	R. VENZON
				NO. OF UNITS	6
				MODEL #	QM10024
				TYPE	QGMCBCVR-24U 6W
				DO NOT SCALE DRAWING	
				UNITS	MM
				SCALE	AS SHOWN
				PROJECT	11TR02017
				DATE	11/2/2017
				BY	R. VENZON
				NO. OF UNITS	6
				MODEL #	QM10024
				TYPE	QGMCBCVR-24U 6W
				DO NOT SCALE DRAWING	
				UNITS	MM
				SCALE	AS SHOWN
				PROJECT	11TR02017
				DATE	11/2/2017
				BY	R. VENZON
				NO. OF UNITS	6
				MODEL #	QM10024
				TYPE	QGMCBCVR-24U 6W
				DO NOT SCALE DRAWING	
				UNITS	MM
				SCALE	AS SHOWN
				PROJECT	11TR02017
				DATE	11/2/2017
				BY	R. VENZON
				NO. OF UNITS	6
				MODEL #	QM10024
				TYPE	QGMCBCVR-24U 6W
				DO NOT SCALE DRAWING	
				UNITS	MM
				SCALE	AS SHOWN
				PROJECT	11TR02017
				DATE	11/2/2017
				BY	R. VENZON
				NO. OF UNITS	6
				MODEL #	QM10024
				TYPE	QGMCBCVR-24U 6W
				DO NOT SCALE DRAWING	
				UNITS	MM
				SCALE	AS SHOWN
				PROJECT	11TR02017
				DATE	11/2/2017
				BY	R. VENZON
				NO. OF UNITS	6
				MODEL #	QM10024
				TYPE	QGMCBCVR-24U 6W
				DO NOT SCALE DRAWING	
				UNITS	MM
				SCALE	AS SHOWN
				PROJECT	11TR02017
				DATE	11/2/2017
				BY	R. VENZON
				NO. OF UNITS	6
				MODEL #	QM10024
				TYPE	QGMCBCVR-24U 6W
				DO NOT SCALE DRAWING	
				UNITS	MM
				SCALE	AS SHOWN
				PROJECT	11TR02017
				DATE	11/2/2017
				BY	R. VENZON
				NO. OF UNITS	6
				MODEL #	QM10024
				TYPE	QGMCBCVR-24U 6W
				DO NOT SCALE DRAWING	
				UNITS	MM
				SCALE	AS SHOWN
				PROJECT	11TR02017
				DATE	11/2/2017
				BY	R. VENZON
				NO. OF UNITS	6
				MODEL #	QM10024
				TYPE	QGMCBCVR-24U 6W
				DO NOT SCALE DRAWING	
				UNITS	MM
				SCALE	AS SHOWN
				PROJECT	11TR02017
				DATE	11/2/2017
				BY	R. VENZON
				NO. OF UNITS	6
				MODEL #	QM10024
				TYPE	QGMCBCVR-24U 6W
				DO NOT SCALE DRAWING	
				UNITS	MM
				SCALE	AS SHOWN
				PROJECT	11TR02017
				DATE	11/2/2017
				BY	R. VENZON
				NO. OF UNITS	6
				MODEL #	QM10024
				TYPE	QGMCBCVR-24U 6W
				DO NOT SCALE DRAWING	
				UNITS	MM
				SCALE	AS SHOWN
				PROJECT	11TR02017
				DATE	11/2/2017
				BY	R. VENZON
				NO. OF UNITS	6
				MODEL #	QM10024
				TYPE	QGMCBCVR-24U 6W
				DO NOT SCALE DRAWING	
				UNITS	MM
				SCALE	AS SHOWN
				PROJECT	11TR02017
				DATE	11/2/2017
				BY	R. VENZON
				NO. OF UNITS	6
				MODEL #	QM10024
				TYPE	QGMCBCVR-24U 6W
				DO NOT SCALE DRAWING	
				UNITS	MM
				SCALE	AS SHOWN
				PROJECT	11TR02017
				DATE	11/2/2017
				BY	R. VENZON
				NO. OF UNITS	6
				MODEL #	QM10024
				TYPE	QGMCBCVR-24U 6W
				DO NOT SCALE DRAWING	
				UNITS	MM
				SCALE	AS SHOWN
				PROJECT	11TR02017
				DATE	11/2/2017
				BY	R. VENZON
				NO. OF UNITS	6
				MODEL #	QM10024
				TYPE	QGMCBCVR-24U 6W
				DO NOT SCALE DRAWING	
				UNITS	MM
				SCALE	AS SHOWN
				PROJECT	11TR02017
				DATE	11/2/2017
				BY	R. VENZON
				NO. OF UNITS	6
				MODEL #	QM10024
				TYPE	QGMCBCVR-24U 6W
				DO NOT SCALE DRAWING	
				UNITS	MM
				SCALE	AS SHOWN
				PROJECT	11TR02017
				DATE	11/2/2017
				BY	R. VENZON
				NO. OF UNITS	6
				MODEL #	QM10024
				TYPE	QGMCBCVR-24U 6W
				DO NOT SCALE DRAWING	
				UNITS	MM
				SCALE	AS SHOWN
				PROJECT	11TR02017
				DATE	11/2/2017
				BY	R. VENZON
				NO. OF UNITS	6
				MODEL #	QM10024
				TYPE	QGMCBCVR-24U 6W
				DO NOT SCALE DRAWING	
				UNITS	MM
				SCALE	AS SHOWN
				PROJECT	11TR02017
				DATE	11/2/2017
				BY	R. VENZON
				NO. OF UNITS	6
				MODEL #	QM10024
				TYPE	QGMCBCVR-24U 6W
				DO NOT SCALE DRAWING	
				UNITS	MM
				SCALE	AS SHOWN
				PROJECT	11TR02017
				DATE	11/2/2017
				BY	R. VENZON
				NO. OF UNITS	6
				MODEL #	QM10024
				TYPE	QGMCBCVR-24U 6W
				DO NOT SCALE DRAWING	
				UNITS	MM
				SCALE	AS SHOWN
				PROJECT	11TR02017
				DATE	11/2/2017
				BY	R. VENZON
				NO. OF UNITS	6
				MODEL #	QM10024
				TYPE	QGMCBCVR-24U 6W
				DO NOT SCALE DRAWING	
				UNITS	MM
				SCALE	AS SHOWN



# TRINITY

## HIGHWAY

*Ahead of the Curve*<sup>®</sup>

For more complete information on Trinity Highway products and services, visit us on the web at [www.trinityhighway.com](http://www.trinityhighway.com). Materials and specifications are subject to change without notice. Please contact Trinity Highway to confirm that you are referring to the most current instructions.

[www.trinityhighway.com](http://www.trinityhighway.com)

888.323.6374 (USA)

+1 214.589.8140 (International)