

QuadGuard[®] M10 24"

Product Description Assembly Manual



TRINITY
HIGHWAY

Ahead of the Curve[®]

QuadGuard® M10 24”

The QuadGuard® M10 has been tested pursuant to American Association of State Highway and Transportation Officials (“AASHTO”) Manual for Assessing Safety Hardware (“MASH”) specifications. The QuadGuard® M10 has been deemed eligible for federal-aid reimbursement on the National Highway System by the Federal Highway Administration (“FHWA”).

Product Description Assembly Manual



2525 N. Stemmons Freeway
Dallas, Texas 75207



Warning: The local highway authority, distributors, owners, contractors, lessors, and lessees are **RESPONSIBLE** for the assembly, maintenance, and repair of the QuadGuard® M10. Failure to fulfill these **RESPONSIBILITIES** with respect to the assembly, maintenance, and repair of the QuadGuard® M10 could result in serious injury or death.



Important: These instructions are for standard assembly specified by the appropriate highway authority. In the event the specified system assembly, maintenance, or repair would require a deviation from standard assembly parameters, contact a Trinity Highway representative. This system has been deemed eligible by the FHWA for use on the national highway system under strict criteria utilized by that agency.

This manual must be available to the worker overseeing and/or assembling the product at all times. For additional copies, contact Trinity Highway directly at (888) 323-6374 or visit TrinityHighway.com.

The instructions contained in this manual supersede all previous information and manuals. The information, illustrations, and specifications in this manual are based on the latest QuadGuard® M10 information available to Trinity Highway at the time of printing. We reserve the right to make changes at any time. Please contact Trinity Highway to confirm that you are referring to the most current instructions.

Table of Contents

Customer Service Contacts	3
Important Introductory Notes	3
Safety Symbols	4
Safety Rules for Assembly	4
Limitations and Warnings.....	5
System Overview	6
Inspect Shipping.....	6
System Components.....	7
Determine Transition Type.....	11
Recommended Tools.....	12
Site Preparation/Foundation	14
Foundation/Anchoring.....	15
Trinity Highway Approved Adhesive Anchoring System	16
Vertical Anchors	16
Anchor Assembly Cautions	17
Horizontal Anchors.....	18
System Assembly	21
QuadGuard® M10 24” Final Inspection Checklist.....	34
Maintenance and Repair.....	35
Inspection Frequency.....	35
Visual Drive-By Inspection	35
Walk-Up Inspection Checklist	35
Post-Impact Instructions.....	36
Parts Ordering Procedure & Drawings.....	38
Parts List(s) & Quantities	38
QuadGuard® M10 w/ Tension Strut Backup QGMTSCVR-U.....	40
Concrete Pad 618686.....	41
Tension Strut Backup 627448	42
Monorail Assembly 625637	43
Diaphragm Assembly 625650	44
Shim Kit 627518.....	45
Fender Panel Assembly 608236	46
Nose Assembly 626814.....	47
QuadGuard® M10 24” Transition to 31” W-Beam Guardrail QGMTSCVR-TWLR	48
QuadGuard® M10 24” Transition to Thrie-Beam Guardrail QGMTSCVR-TTLR.....	49
QuadGuard® M10 24” Transition to Safety Shape Barrier QGMTSCVR-T4.....	50
QuadGuard® M10 24” Transition to Single Slope QGMTSCVR-T6.....	51
QuadGuard® M10 24” Transition to Vertical Barrier QGMTSCVR-ES.....	52
QuadGuard® M10 24” Transition to Vertical Barrier, Extended QGMTSCVR-SPE	53

Customer Service Contacts

Trinity Highway is committed to the highest level of customer service. Feedback regarding the QuadGuard® M10, its assembly procedures, supporting documentation, and performance is always welcome. Additional information can be obtained from the contact information below:

Trinity Highway

Telephone	(888) 323-6374 (USA) +1 312 467-6750 (International)
Contact Link	TrinityHighway.com/Contact

Important Introductory Notes

Proper assembly of the QuadGuard® M10 is critical to achieve performance that has been evaluated and deemed eligible by the FHWA per AASHTO MASH criteria. These instructions should be read in their entirety and understood before assembling the QuadGuard® M10. These instructions are to be used in conjunction with the assembly of QuadGuard® M10 and are for standard assemblies only as specified by the applicable highway authority. If you need additional information, or have questions about the QuadGuard® M10, please contact the highway authority that has planned and specified this assembly and, if needed, contact Trinity Highway's Customer Service Department. This product must be assembled in the location specified by the appropriate highway authority. If there are deviations, alterations, or departures from the assembly protocol specified in this manual, the device may not perform as tested.



Important: DO NOT use any component part that has not been specifically specified herein for the QuadGuard® M10 during the assembly or repair of this system (p. 7 – 10 / 38 - 39).

This product has been specified for use by the appropriate highway authority and has been provided to that user who has unique knowledge of how this system is to be assembled. No person should be permitted to assist in the assembly, maintenance, or repair of this system that does not possess the unique knowledge described herein. These instructions are intended for an individual qualified to both read and accurately interpret them as written. These instructions are intended only for an individual experienced and skilled in the assembly of highway products that are specified and selected by the highway authority.

A Manufacturer's Drawing Package will be supplied by Trinity Highway upon request. Each system will be supplied with a specific drawing package unique to that system. Such drawings take precedence over information in this manual and shall be studied thoroughly by a qualified individual who is skilled in interpreting them before the start of any product assembly.

Safety Symbols

This section describes the safety symbols that appear in this QuadGuard® M10 manual. Read the manual for complete safety and assembly information.

Symbol

Meaning



Safety Alert Symbol: Indicates Important, Caution, Warning, or Danger. Failure to read and follow the Important, Caution, Warning, or Danger indicators could result in serious injury or death to workers and/or bystanders.



Warning: Read safety instructions thoroughly and follow the assembly directions and suggested safe practices before assembling, maintaining, or repairing the QuadGuard® M10. It is the responsibility of the installer to follow the instructions contained in this manual. Failure to comply with these warnings could result in increased risk of serious injury or death in the event of a vehicle impact.



Important: Please keep up-to-date instructions for later use and reference by anyone involved in the assembly of the product.

Safety Rules for Assembly

*** Important Safety Instructions ***

This manual must be kept in a location where it is readily available to persons who are skilled and experienced in the assembly, maintenance, or repair of the QuadGuard® M10. Additional copies of this manual are available from Trinity Highway by calling (888) 323-6374 or by visiting TrinityHighway.com/Contact. Please contact Trinity Highway if you have any questions concerning the information in this manual or about the QuadGuard® M10.

It is the responsibility of the installer to use appropriate safety precautions when operating power equipment, mixing chemicals, and when moving heavy equipment or QuadGuard® M10 components. Safety articles including but not necessarily limited to work gloves, eye protection, safety-toe shoes, and back protection should be used.



Warning: It is the responsibility of the installer to use all safety measures incorporating appropriate traffic control devices specified by the highway authority. These measures must be used to protect all personnel while at the assembly, maintenance, or repair site.



Warning: Failure to comply with these warnings could result in increased risk of serious injury or death in the event of a vehicle impact with a system that has not been accepted by the FHWA.



Warning: Use only Trinity Highway parts on the QuadGuard® M10 for assembly, maintenance, or repair. The use of component parts not specified herein is **strictly prohibited**. The QuadGuard® M10 assembled with Trinity Highway Parts has been tested, approved, and accepted for state use by the FHWA. A QuadGuard® M10 Assembly using parts other than those specified herein has not been tested, approved, or accepted for state use by the FHWA. Failure to follow this warning could result in increased risk of serious injury or death in the event of a vehicle impact.

Limitations and Warnings

Pursuant to MASH “Recommended Procedures for the Safety Performance of Highway Safety Features”, Trinity Highway contracts with FHWA approved testing facilities to perform and evaluate crash tests to prepare a crash test results report. Trinity Highway is then able to submit a Request for Federal Aid Reimbursement of Safety Hardware Devices to the FHWA for review.

The QuadGuard® M10 has been deemed eligible by FHWA as meeting the requirements and guidelines of MASH. These tests evaluate product performance defined by AASHTO involving lightweight cars (approx. 2420 lb. [1100 kg]) and full size pickup trucks (approx. 5000 lb. [2270 kg]). A product can be certified for multiple Test Levels. The QuadGuard® M10 is certified to the Test Level(s) as shown below:

Test Level 3: 62 mph [100 kph]

Test Level 2: 44 mph [70 kph]

These AASHTO directed tests are not intended to represent the performance of systems when impacted by every vehicle type or every impact condition existing on the roadway. This system is tested only to the test matrix criteria of MASH as approved by FHWA.

Trinity Highway expressly disclaims any warranty or liability for injury or damage to persons or property resulting from any impact, collision or harmful contact with products, other vehicles, or nearby hazards or objects by any vehicle, object or person, whether or not the products were assembled in consultation with Trinity Highway or by third parties.

The QuadGuard® M10 is intended to be assembled, delineated, and maintained within specific state and federal guidelines. It is important for the highway authority specifying the use of a highway product to select the most appropriate product configuration for site specifications. The customer should be careful to properly select, assemble, and maintain the product. Careful evaluation of site layout, traffic speed/type, direction, and visibility are some of the elements that require evaluation by the highway authority in the selection of a highway product. For example, curbs could cause an untested effect on an impacting vehicle.

After an impact occurs, the debris from the impact should be removed from the area immediately and the specified highway product should be evaluated and restored to its original specified condition or replaced as the highway authority determines as soon as possible.



Warning: Do not assemble, maintain, or repair the QuadGuard® M10 until you have read this manual thoroughly and completely understand it. Ensure that all Danger, Warning, Caution, and Important statements within the manual are completely followed. Please call Trinity Highway at (888) 323-6374 if you do not understand these instructions.



Warning: Ensure that all of the QuadGuard® M10 Danger, Warning, Caution, and Important statements within the QuadGuard® M10 manual are completely followed. Failure to follow this warning could result in serious injury or death in the event of a collision.

System Overview

The QuadGuard® M10 is a re-directive, non-gating crash cushion for roadside features of 24" [610 mm] or greater in width with use of approved transitions. It consists of energy-absorbing cartridges surrounded by a framework of Quad-Beam Fender Panels.



Important: Trinity Highway makes no recommendation whether use or reuse of any part of the system is appropriate or acceptable following an impact. It is the sole responsibility of the project engineer and/or the local highway authority and its engineers to make that determination. It is critical that you inspect this product after assembly is complete to make certain that the instructions provided in this manual have been strictly followed.

The QuadGuard® M10 utilizes two types of cartridges in a “staged” configuration that are designed and tested to address vehicles as defined by MASH for both lighter cars and heavier, high center-of-gravity vehicles.

Impact Performance

The six (6) Bay QuadGuard® M10 has successfully passed the requirements stipulated in MASH with both the light car and pickup trucks at speeds of up to 62 mph [100 kph] at redirection angles up to 25 degrees.

The three (3) Bay QuadGuard® M10 has successfully passed the requirements stipulated in MASH with both the light car and pickup trucks at speeds of up to 44 mph [70 kph] at redirection angles up to 25 degrees.

During head-on impact testing, within MASH criteria, the QuadGuard® M10 has been shown to telescope rearward to absorb the energy of impact. When impacted from the side, within the applicable MASH criteria, it has been shown to redirect the vehicle back toward its original travel path and away from the highway feature.



Warning: It is the sole responsibility of the project engineer and/or local highway authority and its engineer to ensure that the QuadGuard® M10 and delineation used meet all federal, state, specifying agency, and local specifications.



Warning: It is the sole responsibility of the project engineer and/or local highway authority and its engineer to ensure that the QuadGuard® M10 meets all appropriate Manual on Uniform Traffic Control Devices (“MUTCD”) and local standards.

Inspect Shipping

Check the received parts against the shipping list supplied with the system before deploying the QuadGuard® M10. Make sure all parts have been received (p. 38 - 39).



Important: The Manufacturer’s Drawing Package supplied with the QuadGuard® M10 must be used with these instructions for proper assembly and should take precedence over these general instructions.









Warning: Do NOT modify the QuadGuard® M10 in any way.

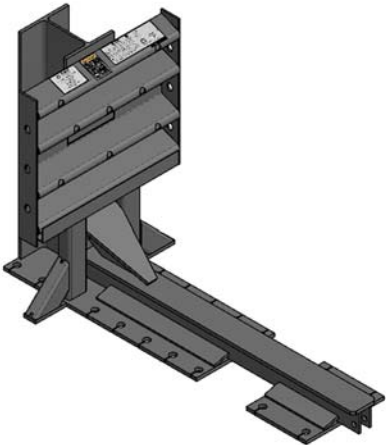
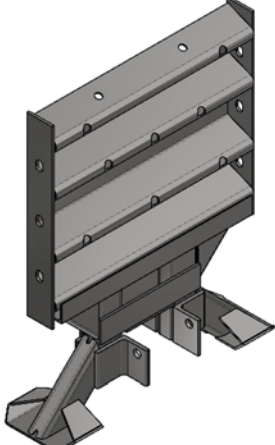
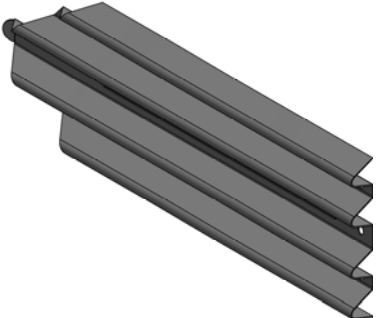

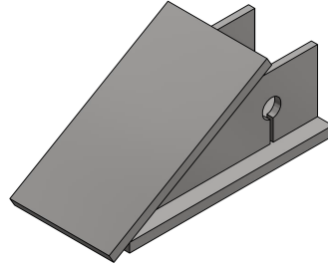
System Components

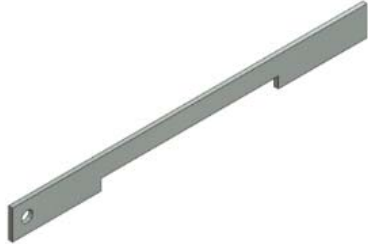
Below is a list of system components that may be used in your particular QuadGuard® M10 configuration. Verify parts delivered and system details with the BOM (Bill of Materials) and system drawings shipped with your system. Please call Trinity Highway if you have any system questions (p. 3).

Note: Components are not shown to scale.

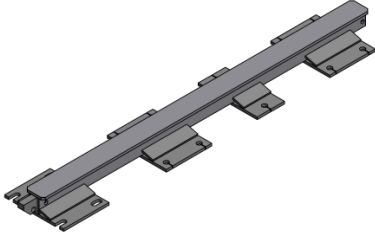
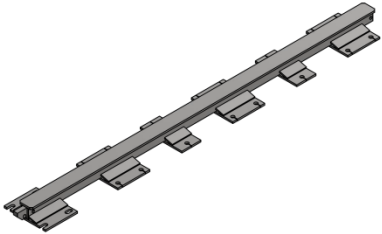
<p>Tension Strut Backup 24"</p>  <p>626055</p>	<p>Diaphragm 24"</p>  <p>625647</p>	<p>Panel, Fender, QG</p>  <p>611832</p>
<p>Panel, Side, QG</p>  <p>611898</p>	<p>Bracket, Cartridge Support</p>  <p>605446</p>	<p>End Cap, Monorail, QG, G</p>  <p>608136</p>
<p>Bracket, Cartridge Support TS B/U</p>  <p>605447</p>	<p>Locking Bar, Cartridge Support</p>  <p>611266</p>	<p>Pipe, 3/4" Sch 80X3</p>  <p>627537</p>

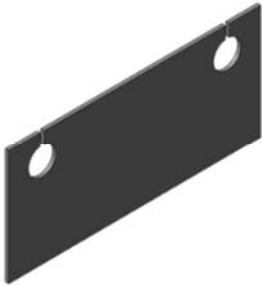
<p>Monorail Guide</p> 	<p>Monorail, Two Bays, QG, G</p> 	<p>Monorail, Three Bays, QG, G</p> 
611368	611375	611379

<p>Shim, 12GAX3 5/8X8</p> 	<p>Bracket, Angle, 2X1, W/Holes</p> 	<p>Bracket, Pull-Out</p> 
614062	626817	605535

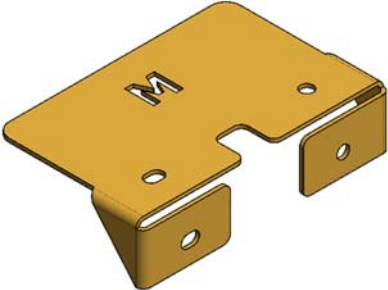
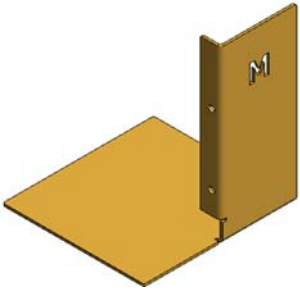
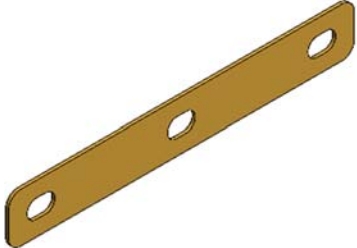

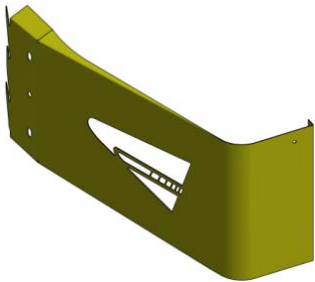
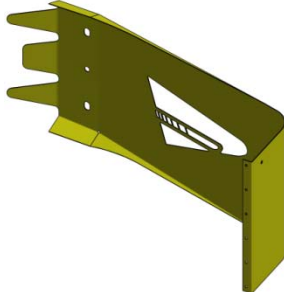
<p>Bracket, Cart, Hold Down</p> 	<p>Bracket, Cart Support, Nose</p> 	<p>Washer, Bar, 1/4</p> 
626815	626816	626818

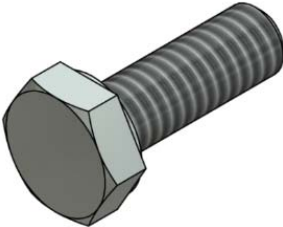
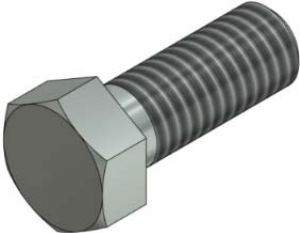
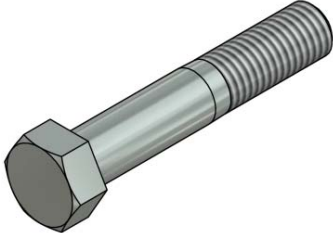
<p>Nose, L, W/Logo</p> 	<p>Nose, R, W/Logo</p> 
611669	611680





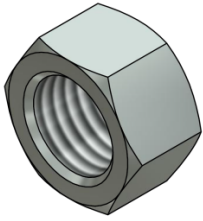
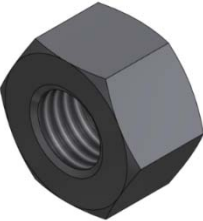

Bolt, Hex, 1/4X3/4, G5	Bolt, Hex, 3/8X1, G5	Bolt, Hex, 5/8X3 1/2, G5
		
113518	113596	113660

Rail Bolt, 5/8X2	Bolt, Rail 5/8-11X5	Bolt, Hex, 3/4X2, G8
		
003400	004441	113555

Anchor, 3/4X6 1/2, G5	Anchor, 3/4X7, G5	Anchor, 3/4X18, G5
		
117540	117542	116799

Nut, Hex, 1/4	Nut, Hex, 3/8	Rail Nut, Hex, 5/8
		
115946	115960	003340

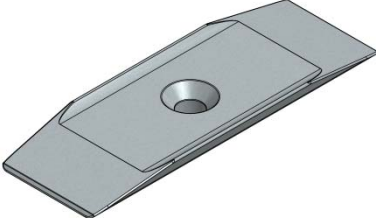
Nut, Hex, 5/8	Nut, Heavy Hex, 3/4
	
003354	003704

<p>Washer, Lock, 5/8</p>  <p>118100</p>	<p>Washer, Lock, 3/4</p>  <p>118089</p>	<p>Washer, Flat 3/8X1</p>  <p>118036</p>
<p>Washer, Flat, 5/8X1 3/4</p>  <p>003300</p>	<p>Washer, Fender, 3/8X2</p>  <p>118038</p>	<p>Washer, Flat, 3/4X2</p>  <p>118027</p>
<p>Mushroom Washer</p>  <p>617045</p>	<p>Flat Screw 5/8X5,G8</p>  <p>116878</p>	<p>Die Spring, 5/8 X 1 1/2</p>  <p>117459</p>
<p>Cartridge Assy, Type I</p>  <p>606027</p>	<p>Cartridge Assy, Type II</p>  <p>606029</p>	<p>Approved Adhesive</p>  <p>118710</p>

Determine Transition Type

Note: A proper Transition Panel or Side Panel must be used on each side of the Backup. A Side Panel is not needed when a Transition Panel is used. The correct Panel(s) to use will depend on the direction of traffic and what type of barrier or road feature the QuadGuard® M10 is shielding. Contact the Customer Service Department prior to deployment if you have any questions (p. 3).

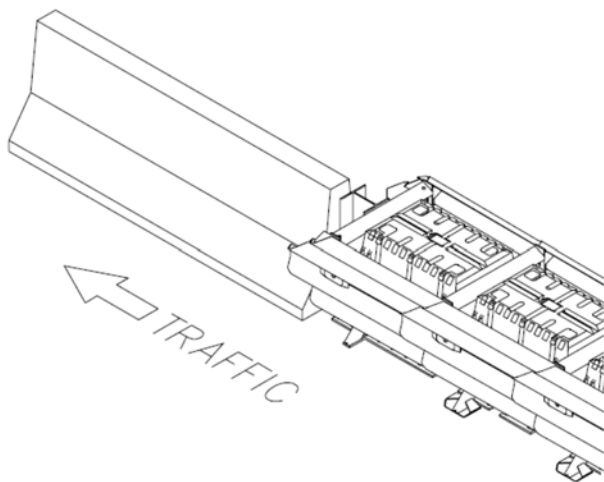

Figure 1
No Transition
(Unidirectional only)

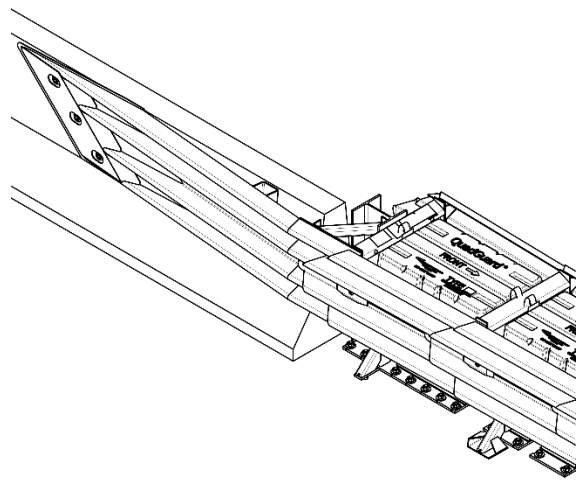

Figure 2
Safety Shape 4'' Offset

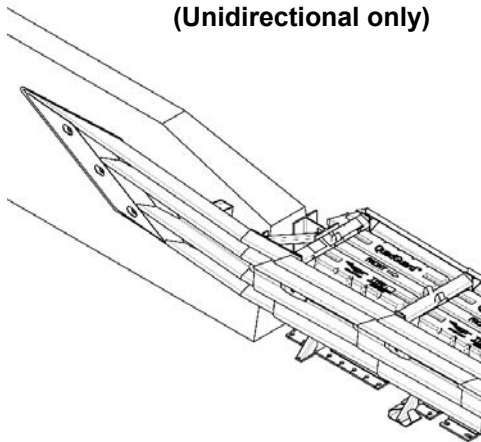

Figure 3
Single Slope 6'' Offset

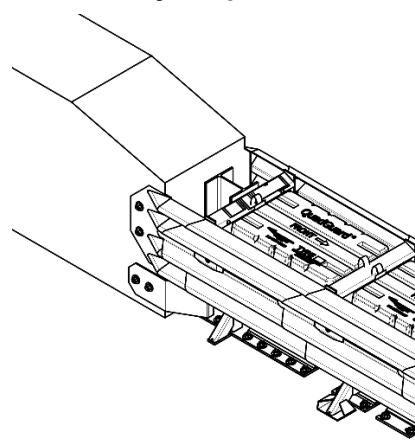

Figure 4
End Shoe

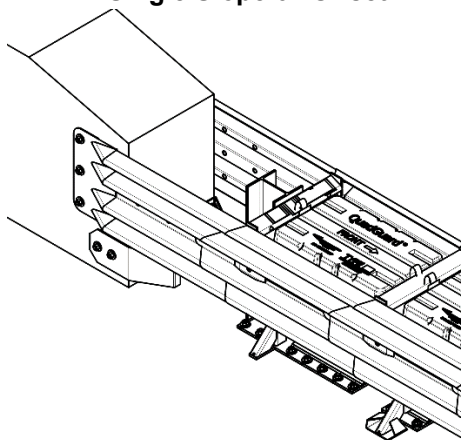

Figure 5
Extended End Shoe

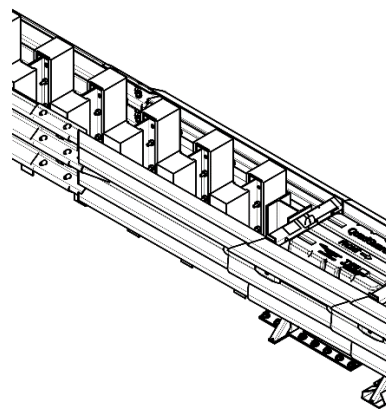

Figure 6
Quad to Thrie-Beam

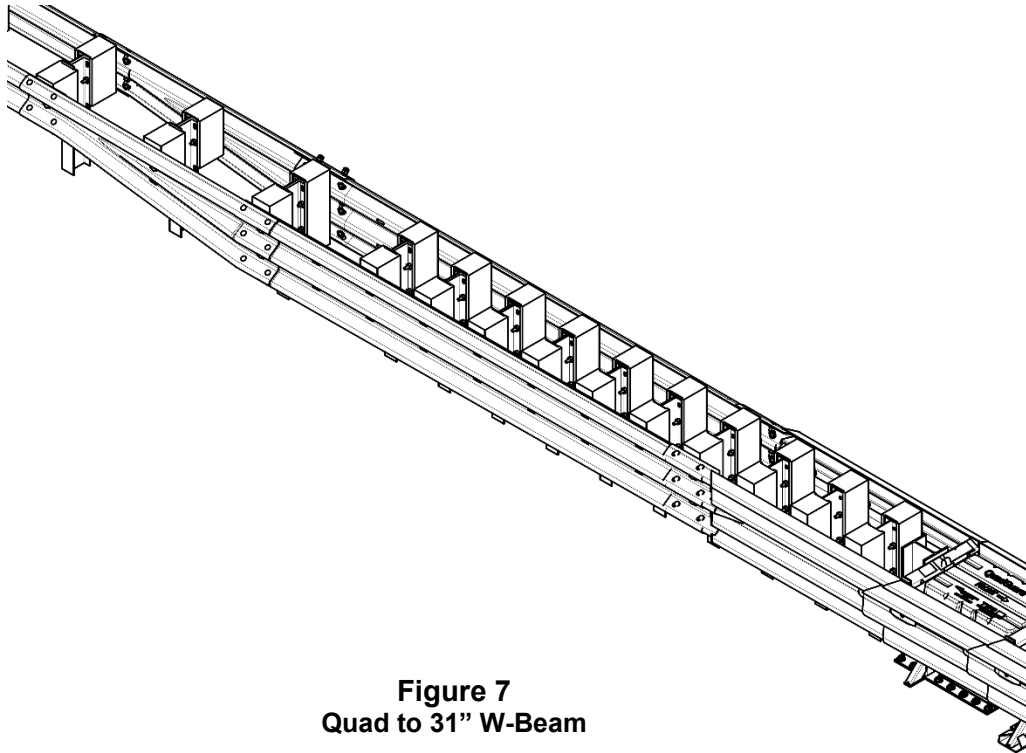

Figure 7
Quad to 31" W-Beam

Recommended Tools

Documentation

- Manufacturer's Assembly Manual
- Manufacturer's Drawing Package

Personal Protective equipment

- Eye Protection
- Gloves
- Safety-toe Shoes
- Protective Clothing
- Reflective Vest

Cutting equipment

- Rotary Hammer Drill
- Rebar cutting bit
- Concrete drill bits – 7/8" [22 mm] (**Double-Fluted**)
- Grinder, Hacksaw or Torch (optional)



Important: Trinity Highway recommends using **double-fluted** drill bits to achieve optimum tensile strength when applying an approved adhesive anchoring system (p. 15).

Hammers

- Sledgehammer
- Standard hammer

Wrenches

- Heavy duty 1/2" drive impact wrench
- 1/2" drive sockets: 7/16", 9/16", 15/16", 1 1/16", 1 1/8", 1 1/4"
- 1/2" drive Deep well sockets: 15/16", 1 1/4"
- 1/2" drive Ratchet and attachments
- 1/2" drive Breaker bar – 24" long
- 1/2" drive Torque wrench: 200 ft-lb
- Combination wrench(s): 7/16", 9/16", 15/16", 1 1/8"
- Hex Key (Allen) wrench: 3/8"



Important: Trinity Highway makes no recommendation whether use or reuse of any part of the system is appropriate or acceptable following an impact. It is the sole responsibility of the project engineer and/or the local highway authority and its engineers to make that determination. It is critical that you inspect this product after assembly is complete to make certain that the instructions provided in this manual have been strictly followed.

Miscellaneous

- Traffic control equipment
- Lifting and moving equipment (A lifting device is preferred although a forklift can be used.) Minimum 5,000 lb. capacity required.
- Air Compressor (100 psi minimum) and Generator (5 kW)
- Long pry bar
- Drift pin 12" [300 mm]
- Center punch
- Tape measure 25' [7.5 m]
- Chalk line
- Concrete marking pencil
- Steel bristled tube brush for cleaning 7/8" drilled boreholes
- Rags, water, and solvent for touch-up

Note: The provided list of tools is a general recommendation and should not be considered an extensive list. Depending on specific site conditions and the complexity of the assembly specified by the appropriate highway authority, the required tools may vary. Decisions as to what tools are needed to perform the job are entirely the responsibility of the specifying highway authority and the authority's selected contractor performing the assembly of the system at the authority's specified assembly site.

Site Preparation/Foundation

A QuadGuard® M10, for permanent applications, should be assembled on an existing or freshly placed and cured concrete base (28 MPa [4000 psi] minimum). Location and orientation of the concrete base and attenuator must comply with project plans or as otherwise determined by the local highway authority.

Recommended dimension and reinforcement specifications for new concrete foundations are provided in Trinity Highway concrete foundation drawings, supplied with the system. The system may be assembled on a non-reinforced concrete roadway (minimum 8" [200 mm] thick). Deployment cross-slope shall not exceed 8% and should not twist more than 2% over the length of the system; the foundation surface shall have a light broom finish.



Warning: It is the responsibility of the installer to ensure proper site grading for the QuadGuard® M10 placement as dictated by the state or specifying agency pursuant to the AASHTO Roadside Design Guide.



Caution: Accurate placement of all steel rebar is critical to avoid interference with the concrete anchor bolts.

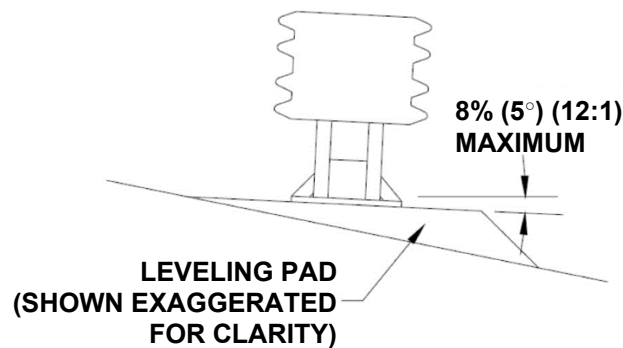

Figure 8
Cross-Slope



Warning: Location of the Backup in relation to nearby objects will affect the operation of the attenuator. Upon impact, the Fender Panels telescope rearward and extend beyond the rigid Backup as much as 30" [760 mm]. Position the Backup so that the rear ends of the last Fender Panels are a minimum of 30" [760 mm] forward of objects that would otherwise interfere with movement of the rearmost Fender Panels. Failure to comply with this requirement is likely to result in system performance which has not been crash tested pursuant to MASH criteria and may also cause component damage which will necessitate maintenance or replacement of the system.



Important: Systems mounted on asphalt must be replaced and mounted on fresh, undisturbed asphalt if more than 10% of anchors are found to be loose, broken, or show signs of pull out. If 10% or fewer anchors are damaged, replace the damaged anchors in the existing asphalt. Anchor bolts used on systems mounted on asphalt must be inspected every 6 months. Review Maintenance and Repair Instructions and Post-Impact Instructions (pp. 35-38).

Foundation/Anchoring



Important: It is the responsibility of the local DOT or appropriate highway authority to ensure that this assembly conforms to the AASHTO Roadside Design Guide.



Warning: It is the responsibility of the installer to ensure that your assembly procedure meets all appropriate Occupational Safety and Health Administration (“OSHA”) and local standards.

Asphalt Installations

Systems with a Tension-Strut Backup may be temporarily installed in construction zones on asphalt. Assemblies on **Asphalt Concrete (“A.C.”)** must provide a minimum of 3” [76 mm] layer of asphalt over a minimum of 3” [76 mm] layer of **Portland Cement Concrete (“P.C.C.”)**, 6” [152 mm] layer of asphalt over 6” [152 mm] layer of subbase, or 8” [200 mm] layer of asphalt with no subbase.



Important: Only 18” [460 mm] threaded rods, utilizing Trinity Highway approved adhesive, can be used with **asphalt** foundations (p. 15). Contact Trinity Highway for a complete list of approved adhesives (p. 3).

Concrete Installations

For concrete installations, the QuadGuard® M10 should be installed only on an existing or freshly placed and cured concrete base (4000 psi [28 MPa] minimum). Orientation of the concrete base and the attenuator must comply with the project plans or as otherwise determined by the resident project engineer or appropriate highway authority.

Recommended dimension and reinforcement specifications for new concrete pads can be found on the standard drawings.

The QuadGuard® M10 may be installed on any of the following foundations using the specified anchorage:

Foundation A: Reinforced Concrete Pad or Roadway

Foundation: 6” [152 mm] minimum depth P.C.C.

Anchorage: Approved adhesive with 7” [180 mm] studs 5 1/2” [140 mm] embedment

Foundation B: Asphalt over P.C.C.

Foundation: 3” [76 mm] minimum asphalt concrete (A.C.) over 3” [76 mm] minimum P.C.C.

Anchorage: Length of anchor required is 18” [460 mm] and embedment of 16 1/2” [420 mm]

Foundation C: Asphalt over Subbase

Foundation: 6” [152 mm] minimum A.C. over 6” [152 mm] minimum Compacted Subbase (C.S.)

Anchorage: Approved adhesive with 18” [460 mm] studs 16 1/2” [420 mm] embedment

Foundation D: Asphalt Only

Foundation: 8” [200 mm] minimum A.C.

Anchorage: Approved adhesive with 18” [460 mm] studs - 16 1/2” [420 mm] embedment

Trinity Highway Approved Adhesive Anchoring System

A Trinity Highway approved adhesive anchoring system is required to securely anchor crash cushions. Each approved adhesive kit contains adhesive, studs, nuts and washers. Both vertical and horizontal assemblies are possible using an approved adhesive anchoring system.

Vertical Anchors

Note: Read all Trinity Highway approved adhesive instructions before starting.

1) Prepare the Concrete Foundation



Warning: Do not allow anchoring adhesive to contact skin or eyes. See material safety data sheet supplied with adhesive kit for first-aid procedures. Use only in well-ventilated area. Do not use near open flame.



Warning: It is the responsibility of the installer to maintain a safe work area including the use of standard work zone safety equipment & PPE: gloves, safety-toe shoes, and eye / ear protection.

The anchor bolts (studs) that anchor the QuadGuard® M10 Backup and/or Monorail sections to the concrete foundation must be those shipped in the kit or of high strength steel (120,000 psi [830 MPa] minimum tensile strength or equal). These studs must be set in minimum 4000 psi [28 MPa] concrete. Allow the concrete to cure a minimum of seven days before applying anchoring adhesive.

2) Drill Boreholes



Caution: It is the responsibility of the installer to consult OSHA silica respiratory standard 29 CFR 1910.134 for debris removal from borehole(s) and use Trinity Highway approved adhesive to achieve optimum tensile strength. Do not use diamond drill bits for drilling boreholes.

Use the Monorail(s) and Tension Strut Backup as drilling templates. Use a rotary hammer drill to drill the boreholes 7/8" [22 mm] diameter to the recommended depth. See the approved adhesive instructions provided with adhesive kit. Check ensure each borehole is drilled to the proper depth and aligned with the part to be anchored per Anchoring Information table.

Anchoring Information					
Stud Size:	Orientation	Bit Size	Minimum Depth	Torque	Medium
3/4"x 7"	Vertical	7/8" [22 mm]	5 3/4" [145 mm]	Manufacturer Spec	Concrete
3/4"x 18"	Vertical	7/8" [22 mm]	16 3/4" [425 mm]	10 ft-lb [15 N-m]	Asphalt



Important: When mounting on asphalt, initial torque shall be as shown above. Due to the properties of asphalt, anchors may loosen over time. For this reason Trinity Highway recommends anchoring to asphalt only at temporary locations. It is recommended to re-torque anchors in asphalt every six (6) months to the proper initial torque specified.

3) Clean the Boreholes

Blow the concrete dust from the borehole using oil-free compressed air. Thoroughly brush it with a 7/8" diameter steel bristle tube brush and then blow it out again. If the borehole is wet, completely flush it with water while brushing and then blow it clean to remove all water using oil-free compressed air.

Note: Use of the Trinity Highway approved vacuum drilling equipment is authorized to replace the blowing and brushing requirement of Step 3.

4) Apply Approved Adhesive

Fill the borehole 100% full.



Caution: Fill borehole 100% full so it is even with the pavement surface per manufacturer's instructions.

5) Add the Washers and Nuts

Place a flat washer onto the stud then thread a nut on until the end of the stud is flush with the nut (Figure 9).

6) Insert Studs in Boreholes and Wait for Adhesive to Cure

Push the stud down through the part to be anchored and into the borehole.



Caution: Do not disturb or load the stud until the approved adhesive material has fully cured (reference instructions supplied with the approved adhesive kit).

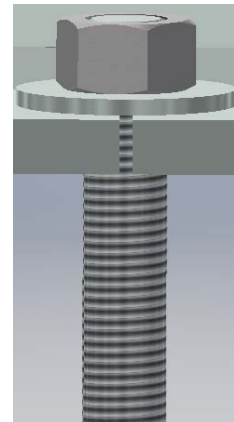

Figure 9
Vertical Application
(Before Applied Torque)

7) Torque the Nuts

Once the adhesive has fully cured, torque the nut to the adhesive manufacturer's recommended values.

Anchor Assembly Cautions

1) Steel rebar

If steel rebar is encountered while drilling an anchor bolt borehole, apply one of the following solutions:

A) Use a rebar drill bit for the **rebar only** and then switch back to the concrete bit to finish drilling into the underlying concrete until the proper borehole depth is reached.



Caution: Do not drill through rebar without first obtaining permission to do so from the project engineer.

B) Drill a new borehole down at an angle past the rebar to the proper depth. Anchor the stud by completely filling both boreholes with an approved adhesive.

Horizontal Anchors

The horizontal approved adhesive kit is the same as the vertical kit.



Caution: Fill borehole 100% full so it is even with the vertical concrete surface per manufacturer's instructions.

1) Follow the instructions supplied with your approved adhesive kit

Apply approved adhesive to each anchor per instructions.

2) Add the Washers and Nuts

Put washer and nut on stud so the **nut is flush with end of stud**.

3) Insert each Stud with Washer and Nut into Borehole

Push stud with washer and nut into borehole.



Important: The stud should be flush with the top of the nut in both **vertical** and **horizontal** applications prior to tightening (Figure 10).

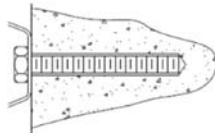

CORRECT

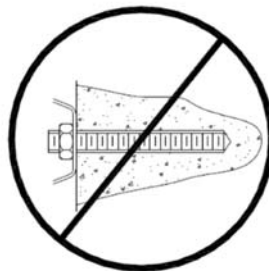

INCORRECT

Figure 10
Horizontal Application
(Before Applied Torque)



Caution: Do not disturb or load the stud until the approved adhesive material has hardened (reference approved adhesive kit instructions for hardening times).

4) Torque the nuts

Once the adhesive has fully cured, torque nut(s) to the approved adhesive manufacturing specification.

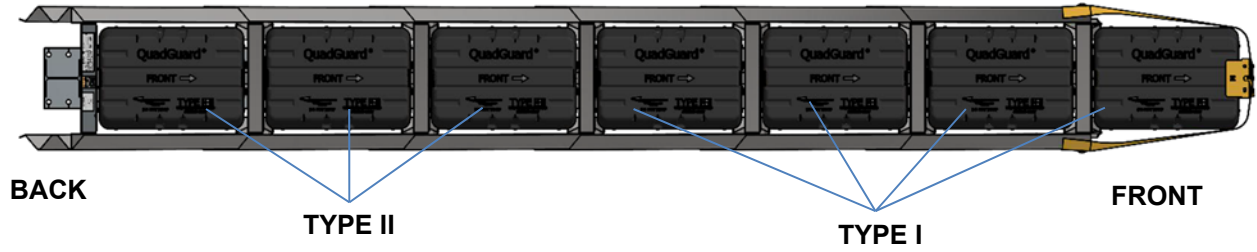

Figure 11 Plan View

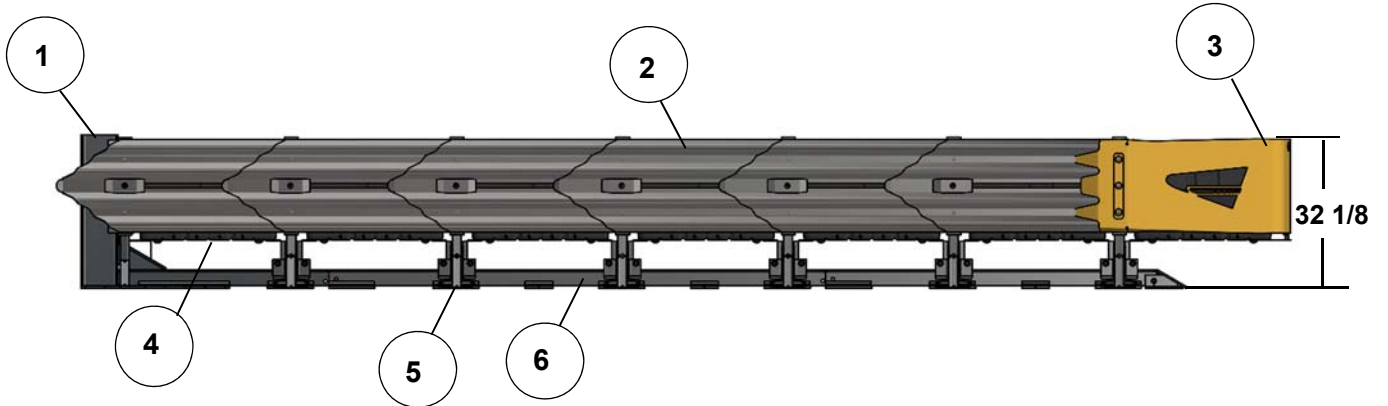

Figure 12 Elevation View
6 Bay TL-3

KEY

- 1) Backup
- 2) Quad-Beam Fender Panel
- 3) Nose Cover
- 4) Cartridge
- 5) Diaphragm
- 6) Monorail

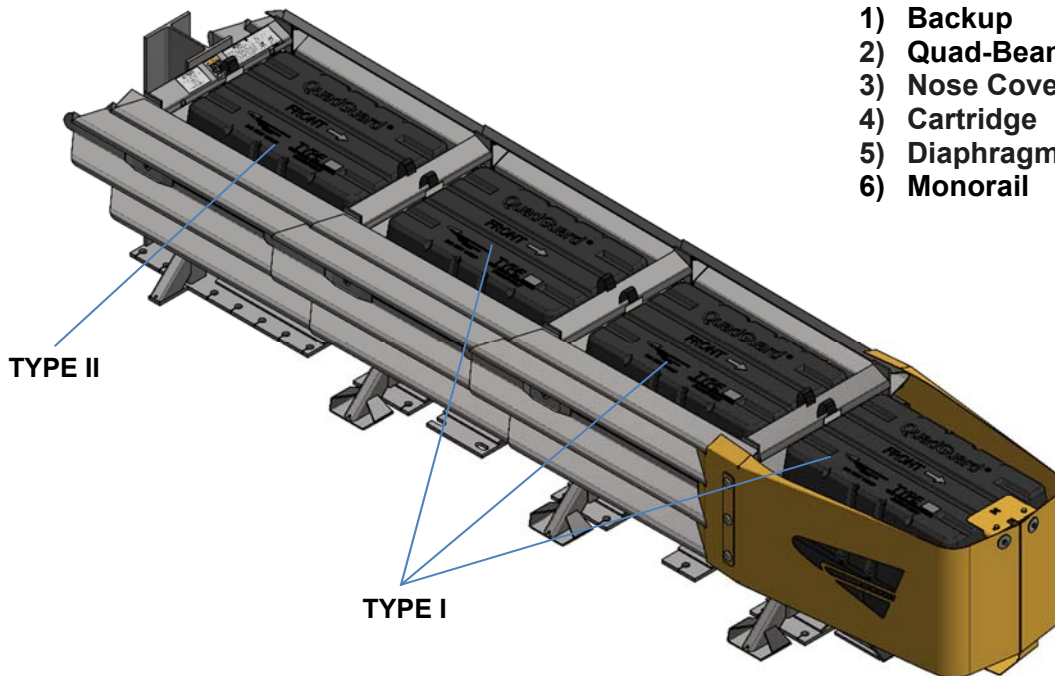

Figure 13
3 Bay TL-2

How to Determine Left/Right

To determine left from right when ordering parts, stand in front of the system facing the roadside obstacle. Your left is the system's left and your right is the system's right.

Counting the Number of Bays

One Bay consists of one Cartridge, one Diaphragm, and two Fender Panels. The Nose section is not considered a Bay, though there is a Cartridge in the Nose of each system.

Note: There will always be one more Cartridge in the system than the number of Bays in the system. To determine number of Bays, count Fender Panels on one side (Figure 14).

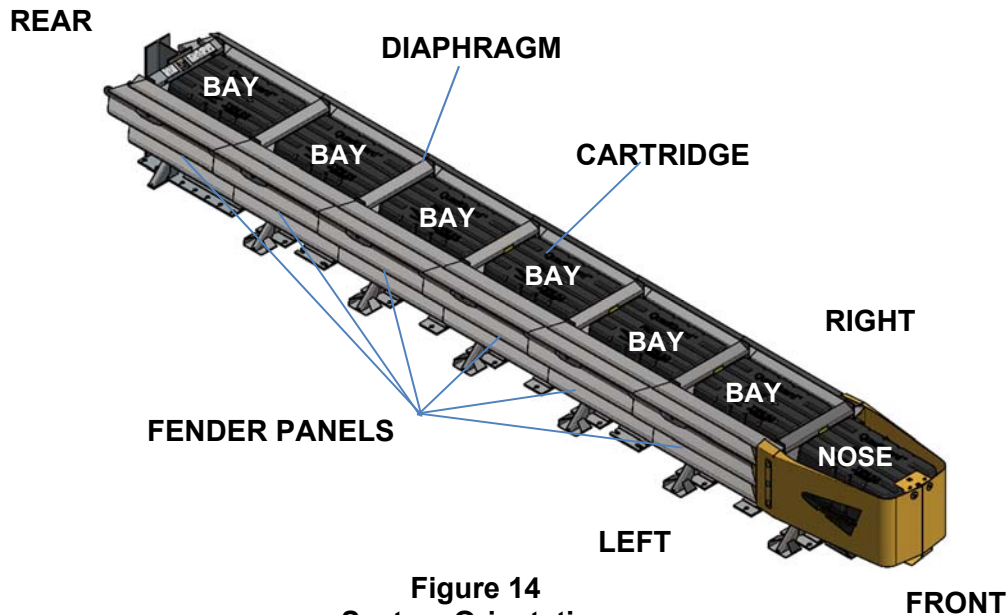

Figure 14
System Orientation

Measuring the Width

The nominal width of the 24" parallel system is the width of the diaphragm (Figure 15).

The outside width of the system is approximately 6" [152 mm] wider than the nominal width.

Note: The outside width of the system is not the same as the width of the Backup.

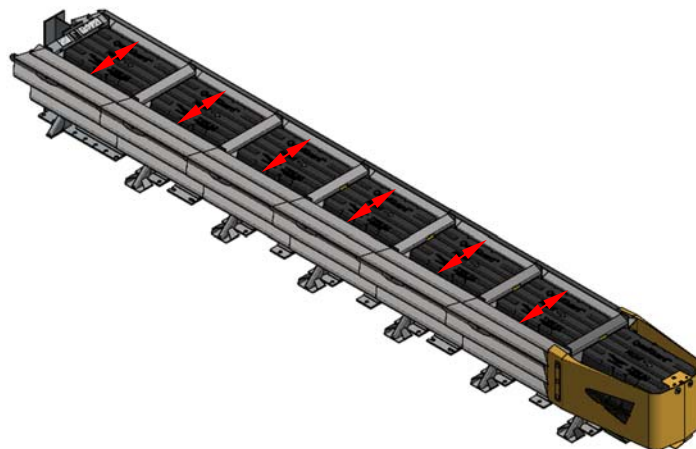

Figure 15
Width of Parallel system

System Assembly



Warning: It is the responsibility of the installer to ensure the assembly procedure meets all appropriate OSHA and local standards.

1) Mark System Location

Locate the centerline of the system by measuring the proper offset from the fixed object. Refer to the Drawing Package supplied with the system. Place chalk line to mark the centerline of the system. Mark a construction line parallel to the center line and offset 6.5" [165 mm] to one side as shown in Figure 16. The edge of the Monorail will be positioned on this line.

Note: The concrete foundation must comply with the Manufacturer's Drawing Package supplied with the system.



Warning: Location of system with respect to the roadside obstacle is critical and dependent on the type of Transition Panel used. Please refer to the Drawing Package supplied with the system for details.

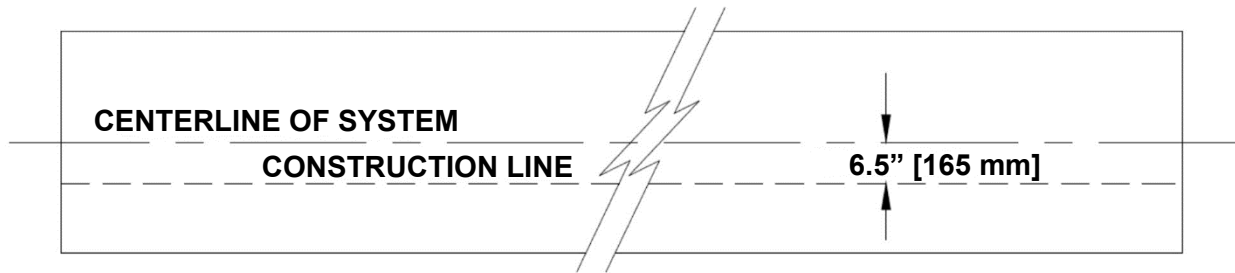

Figure 16
(Top view of concrete foundation)

2) Anchor the Tension Strut Backup (Figure 17)

Locate Tension Strut Backup and Monorail on foundation with side of Monorail on the construction line (p. 24). **Verify that any applicable Transition Panels fit properly before anchoring Backup.** Drill 7/8" [22 mm] diameter by 5 3/4" [145 mm] anchor boreholes in foundation using the Backup as template. Anchor the Backup to the concrete foundation using an approved adhesive supplied with the QuadGuard® M10 (p. 16).

Note: Verify that any applicable Transition Panels fit properly before anchoring Backup.



Caution: Every hole in the Backup and Monorail must be anchored by a stud using an approved adhesive (p. 16).

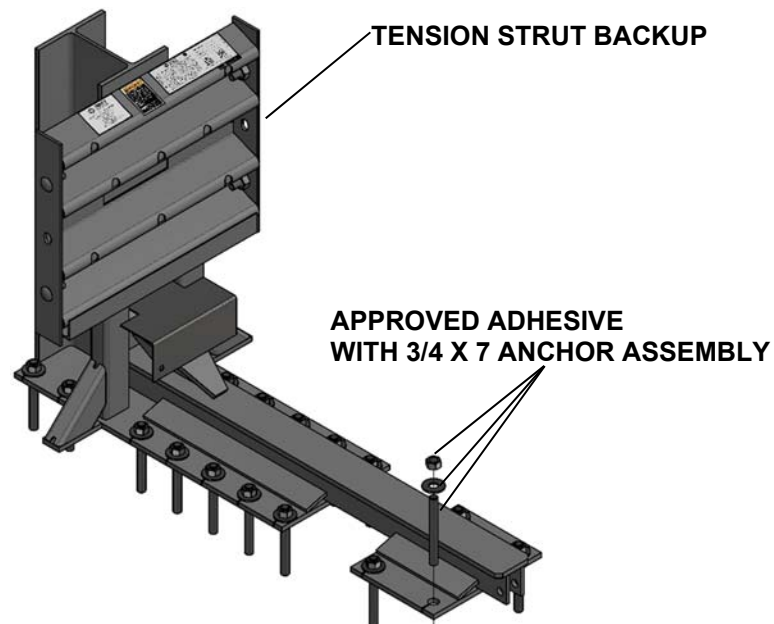

Figure 17
Anchoring Tension Strut Backup to Foundation

3) Anchor the Monorail

Monorail Placement for Tension Strut Backup (Figure 21)

Locate Monorail on foundation with side of Monorail on the construction line and rear edge of Backup foot 4" forward of edge of foundation.

Orient the Monorail so that the Monorail tongues face the Backup.



Warning: Improper alignment at the Monorail splice joints may prevent proper system collapse during an impact (p. 24, Detail 19a).

It is important to align each segment of Monorail from the back to the front of the system ($\pm 1/4$ " [6 mm]). Anchor each Monorail section using the Trinity Highway approved adhesive kits provided (p. 16).

4) Attach Side Panels and/or Transition Panels to Backup Assembly

Attach Transition Panel or Side Panel to side of Backup using 5/8" rail bolt and 5/8" rail nut (two places - top and bottom holes only*). See Backup Assembly drawing(s) **below**.

Note: Do not use a Side Panel when a Transition Panel is used.

Assembly Tip:

Use drift pin to align the center hole of the Side Panel with the center hole of the Backup before inserting the Rail Bolts.

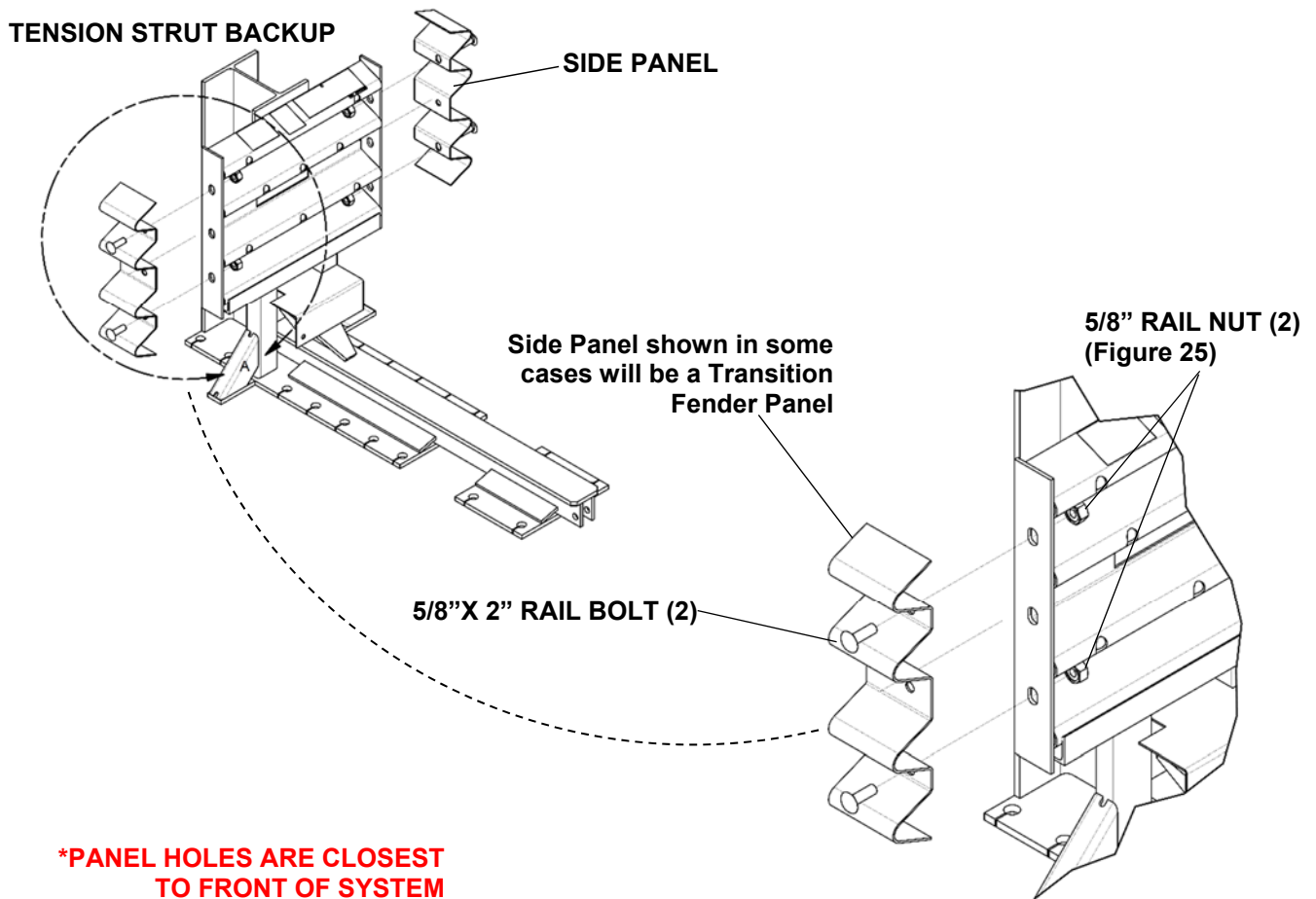
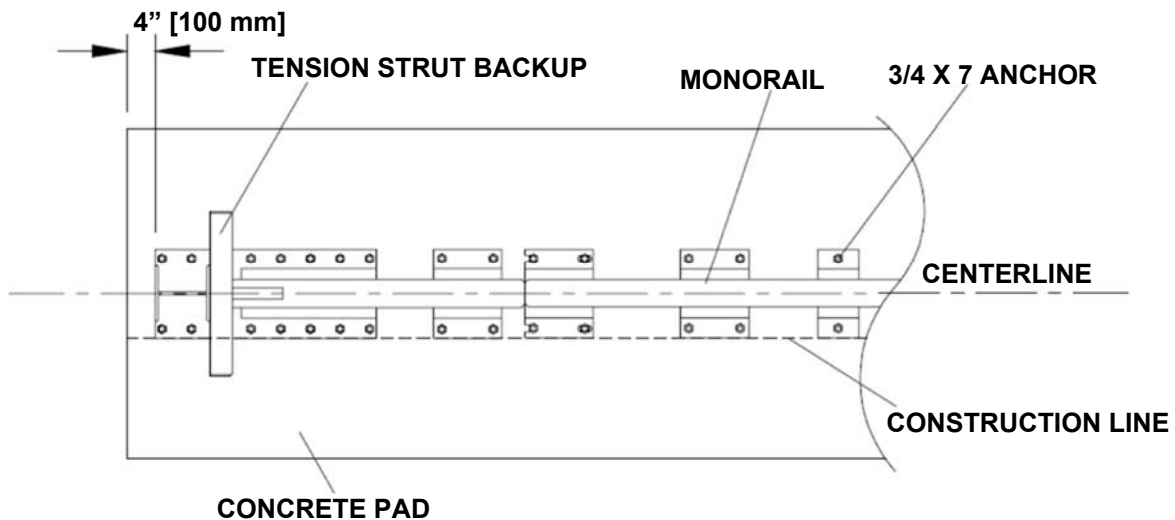
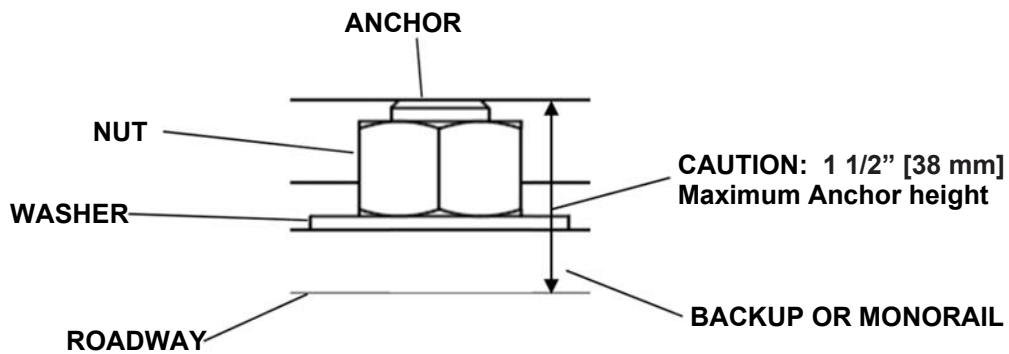
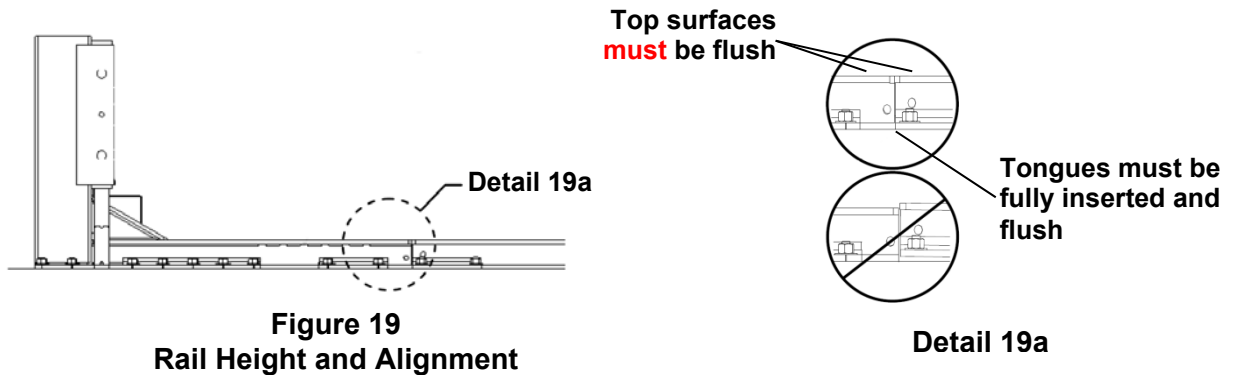

Figure 18
Side Panel/Transition Panel Attachment



Warning: Every hole in the Backup and Monorail must be anchored by a stud using an approved adhesive (p. 16).

Drill 7/8" [22 mm] diameter by 5 3/4" [145 mm] boreholes using the Monorail as a template. Do not drill through foundation.



5) Attach Monorail Guides

Attach Monorail guides to Diaphragm as follows:

Insert 3/4" x 2" G8 hex bolt through Monorail guide and Diaphragm with a shim placed between them and oriented as shown in Figure 22. Secure with 3/4" lock washer and 3/4" hex nut (typical 4 places). See the Diaphragm Assembly drawing supplied with the system.

Repeat process for each Diaphragm.

6) Attach Diaphragms

Orient a Diaphragm so that the front face of the Diaphragm shape faces toward the Nose of the system as shown in Figure 23.



Important: Slide one Diaphragm all the way to the Backup to ensure the system is able to collapse properly during impact.

Orient and slide all other Diaphragms onto Monorail and position each approximately as shown in Figure 24.

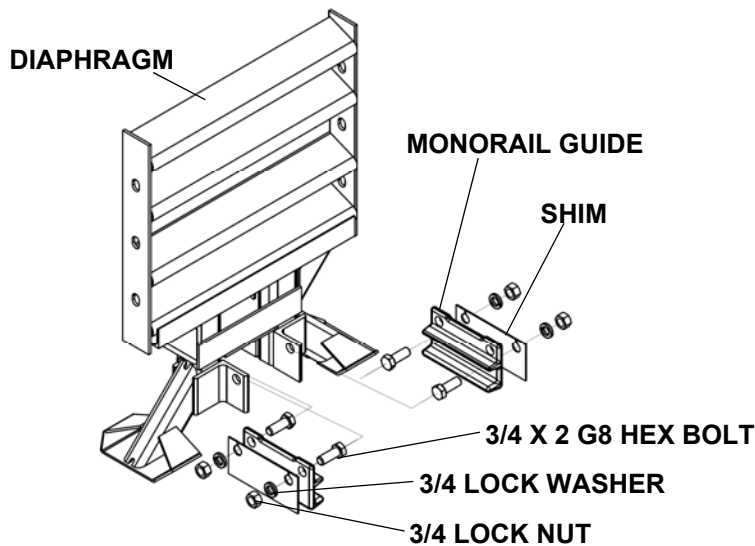

Figure 22
Monorail Guide Attachment

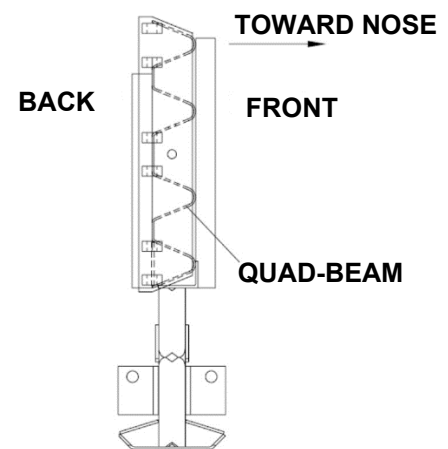

Figure 23
Diaphragm Orientation

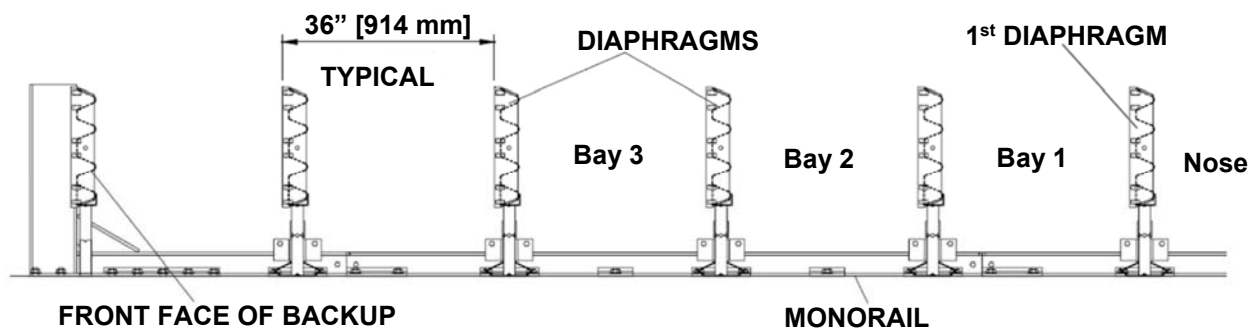

Figure 24
Diaphragm Spacing

7) Attach Fender Panels

Note: Do not mix the 5/8" rail nuts (large) with the 5/8" hex nuts (small) (Figure 25).

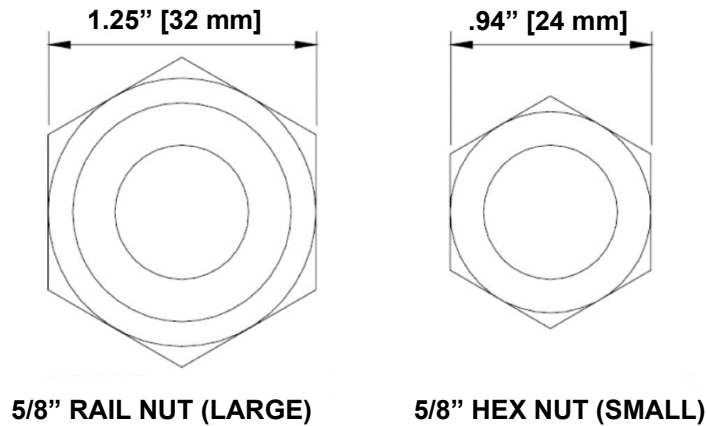

Figure 25
Rail Nuts are Oversize

Note: Starting at the Backup, attach left and right Fender Panels shown below in Step(s) 4 & 5 with each tapered end pointing toward the rear of the system (p. 27).

Step 1

Place the Fender Panel so that the center of the slot of the rearward Diaphragm is lined up with the approximate center of the slot in the Fender Panel.

Attach Mushroom Washer Assembly as shown in Figure 26, Detail 26a, and 26b. Do not torque fasteners at this time. This (Step 1) helps to balance the Fender Panel.

Step 2

Slide the Fender Panel forward until the holes in the Fender Panel line up with the holes in the forward Diaphragm.

Step 3

Use a drift pin to align the center hole of the Fender Panel with the center hole of the Diaphragm.

Note: Working from the Backup, assemble and tighten each Bay section one at a time toward the Nose of the system.

Step 4

Attach the front of the Fender Panels to the next Diaphragm using two (2) rail bolts and large hex nuts per side. Use only the top and bottom holes and leave the center hole open until the next Fender Panel is attached.

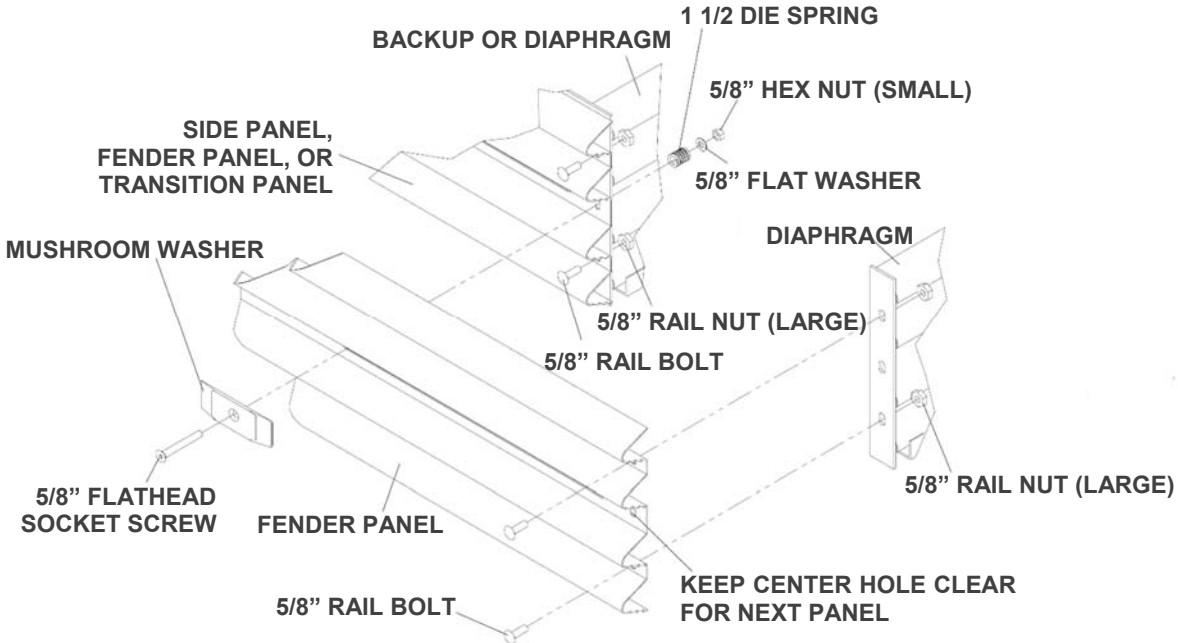
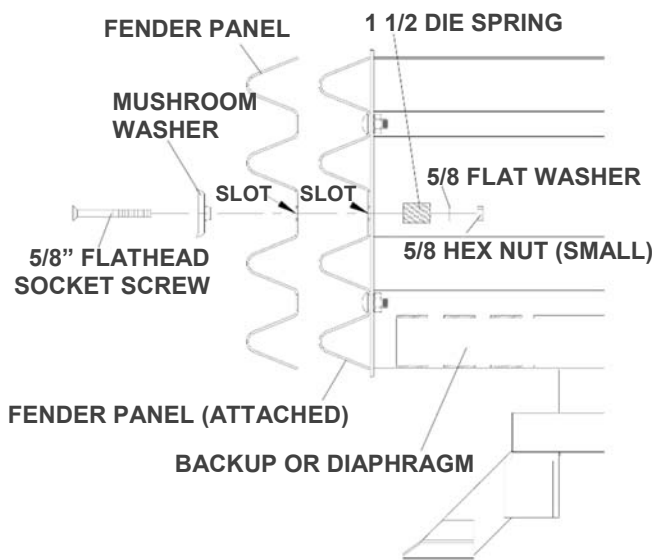

Figure 26
Fender Panel Assembly

Step 5

Be sure Mushroom Washer lays flat against the Fender Panel as shown in Detail 26b. Standoff on Mushroom Washer must be seated completely through slot.



Detail 26a
Mushroom Washer Attachment

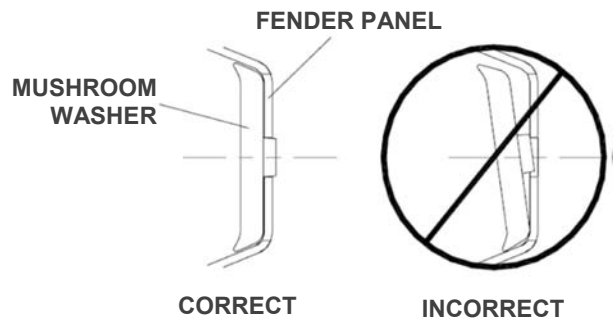

Detail 26b
Mushroom Washer Orientation



Important: Starting from the Backup, attach and tighten each Bay section one at a time.

Step 6

Check Diaphragm spacing to ensure 36" [914 mm] between rear faces of consecutive Diaphragms as shown in Fender Panel assembly drawing (Figure 27).

Step 7

Once proper spacing has been achieved, tighten the Mushroom Washer Assembly (small hex) nut until it reaches the end of the threads.

Assemble the remaining Diaphragms and Fender Panels following the same procedures.

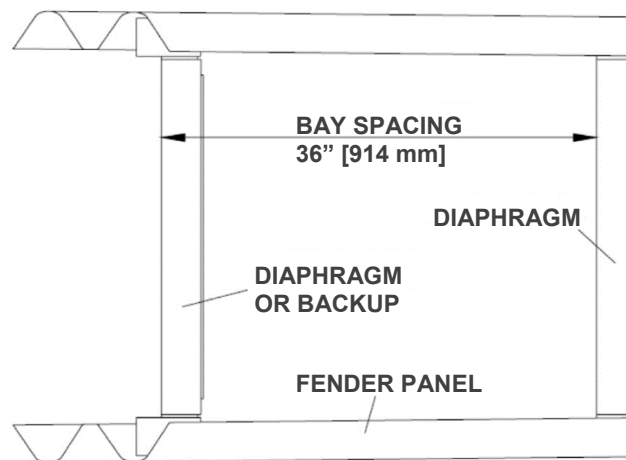

Figure 27
Proper Diaphragm Spacing

8) Attach End Cap

Attach the End Cap to the front of the first Monorail segment, as shown below and the Monorail Assembly drawing.

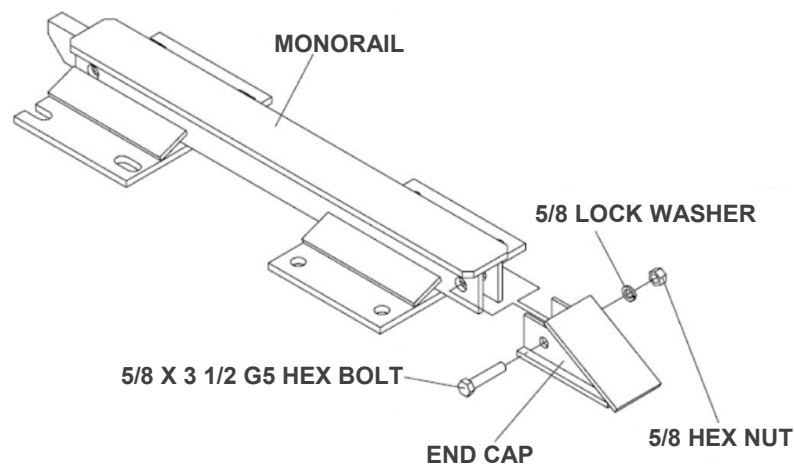

Figure 28
Monorail End Cap Attachment

9) **Attach Lower Cartridge Support Brackets**

Attach lower Cartridge Support Bracket to the front and back of all Diaphragms and also to the front of the Backup as shown below.

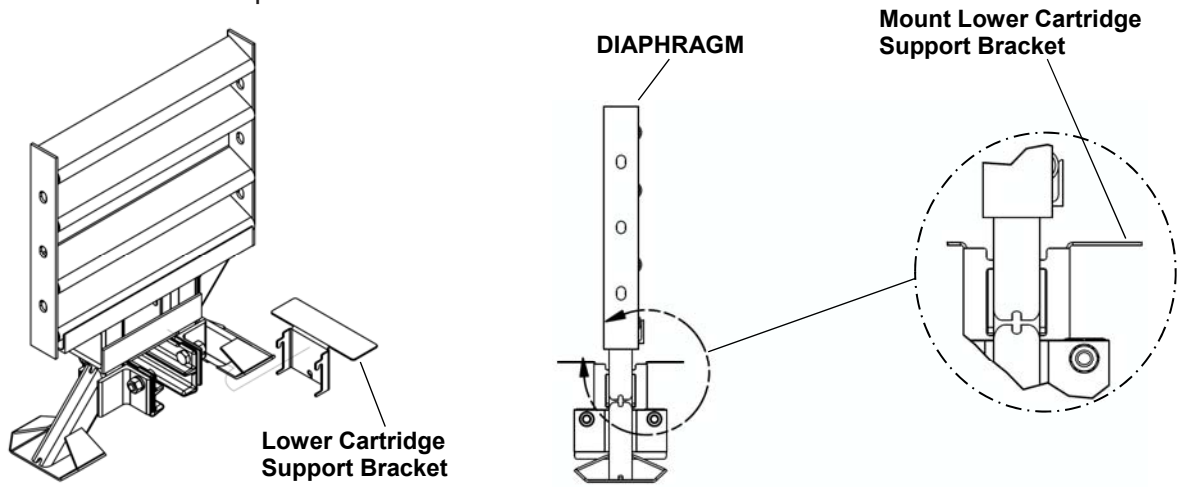

Figure 29
Lower Cartridge Support Bracket Assembly

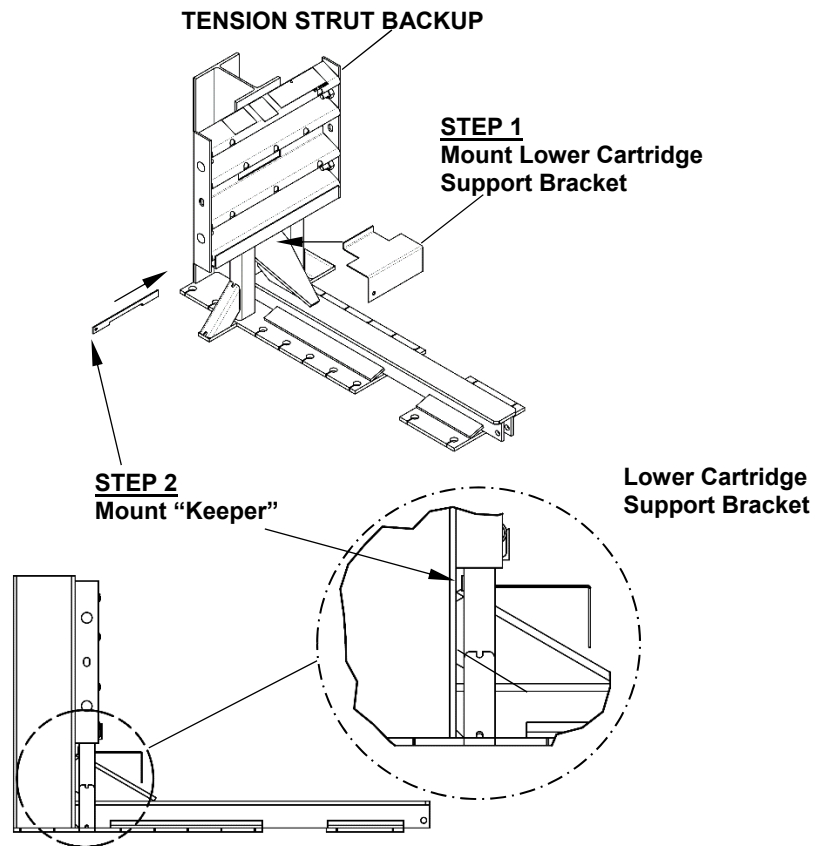
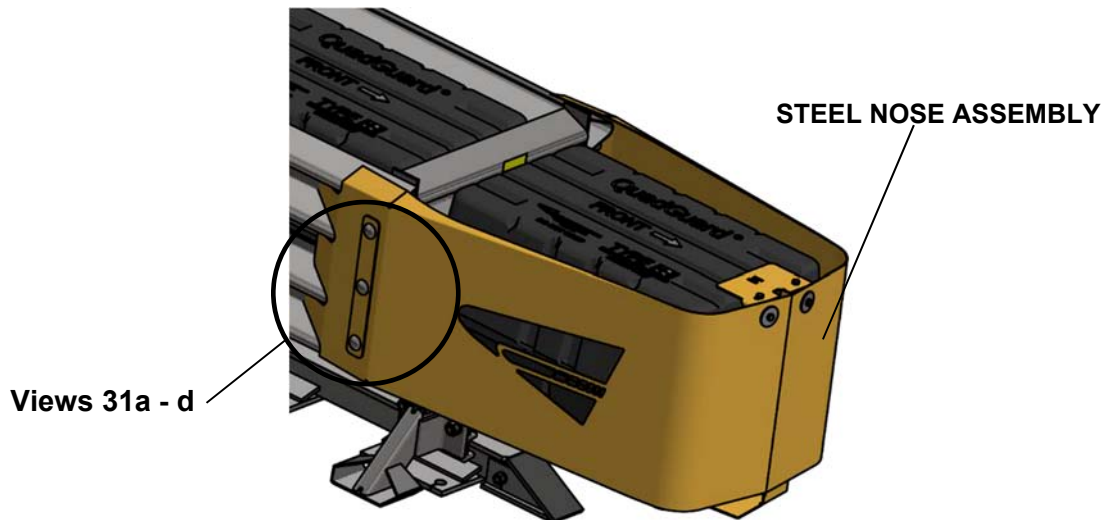

Figure 30
Lower Cartridge Support Bracket Assembly
(Tension Strut Backup)

10) Nose Assembly



**Figure 31
NOSE ASSEMBLY (p. 47)**

- A. Preassemble Left and Right Nose Panels and Cartridge Nose Support Bracket using 1/4X3/4 hex bolt and hex nuts (Detail 31a & 31b).
- B. Attach preassembled Nose Assembly to front Diaphragm with 5/8X5 rail bolts, bar washers, 3/4 sch 80X3" pipe, pullout brackets and 5/8 hex nuts. Do not tighten at this time (Details 31c, 31d, 31e).
- C. Adjust Nose assembly height so top front Nose is 32 1/8 above concrete pad. Tighten all six (6) rail bolts and nuts.
- D. Install Type 1 Cartridge insuring directional arrow is pointing to front of system.
- E. Assemble QuadGuard® M Cartridge Hold Down Bracket with 3/8X1 hex bolts, washers and nuts (Figure 32).

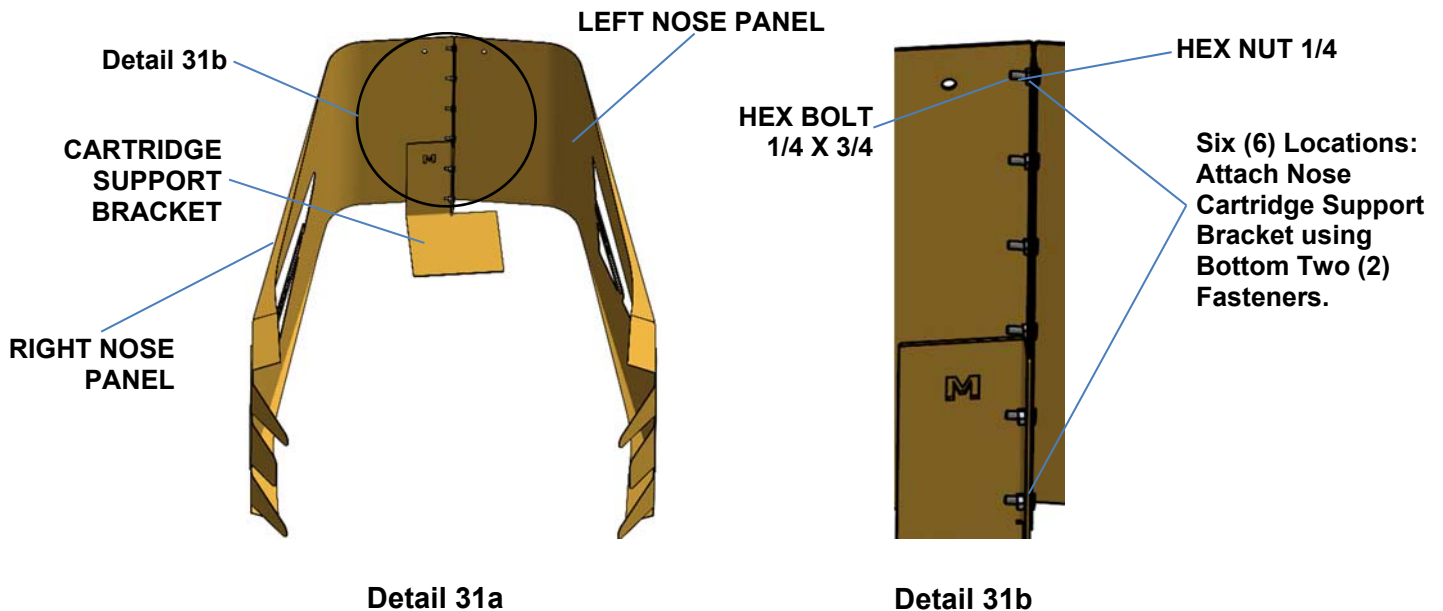

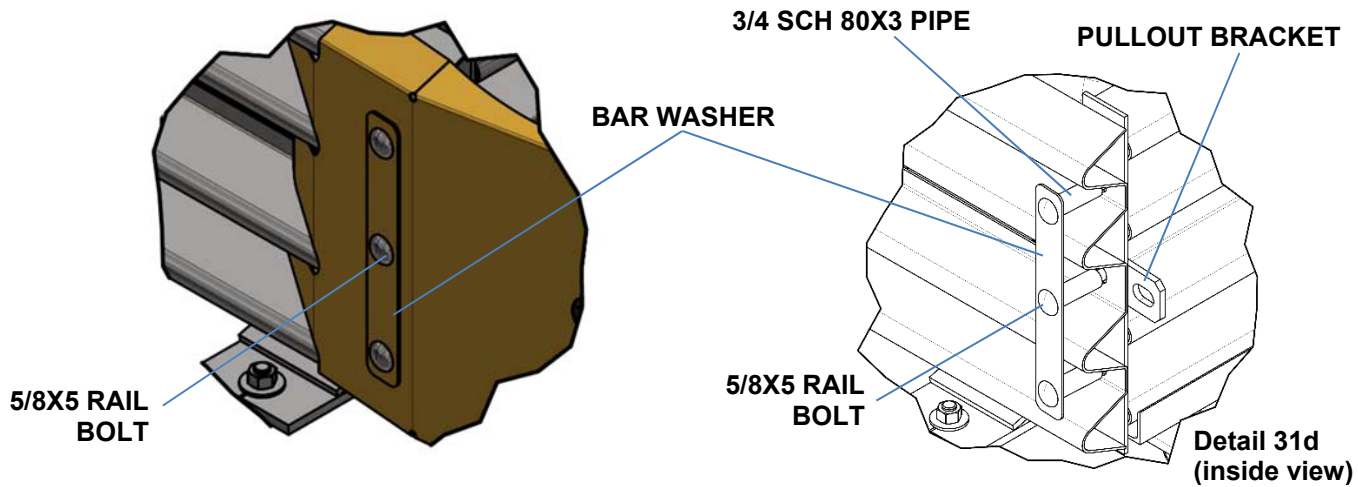

Detail 31c
Fastener Assembly

Detail 31d
Steel Nose not shown for clarity

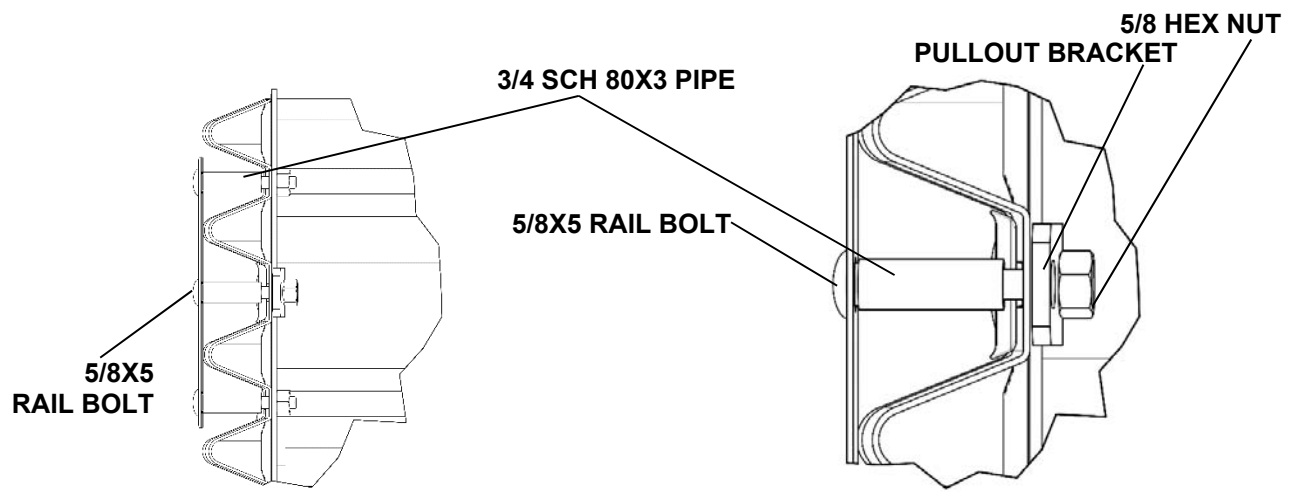

Detail 31e
End View: Nose Cover Removed

Detail 31f
Inside View: Nose Cover Cut Away

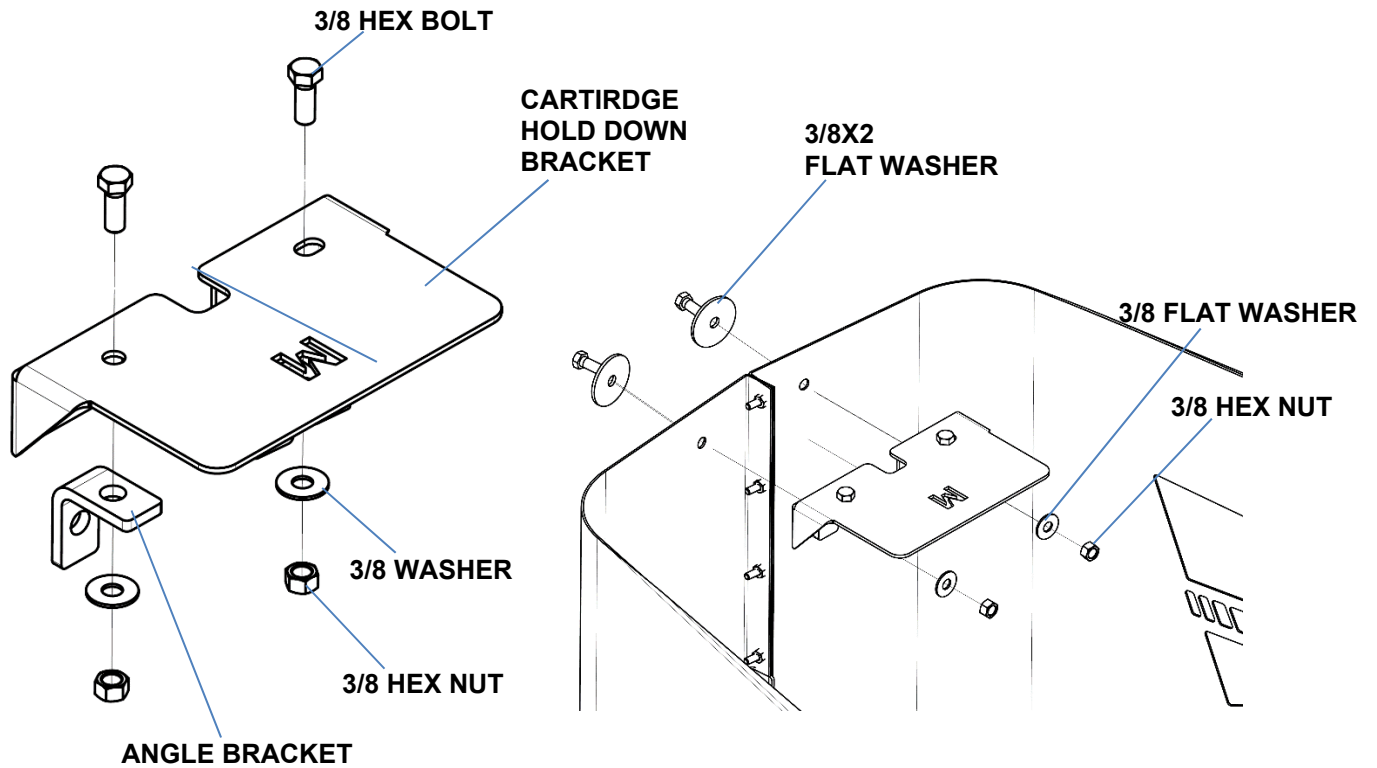

Figure 32
Hold Down Bracket Assembly

Note: Figure 33 shows proper placement of Cartridge Nose Support Bracket.

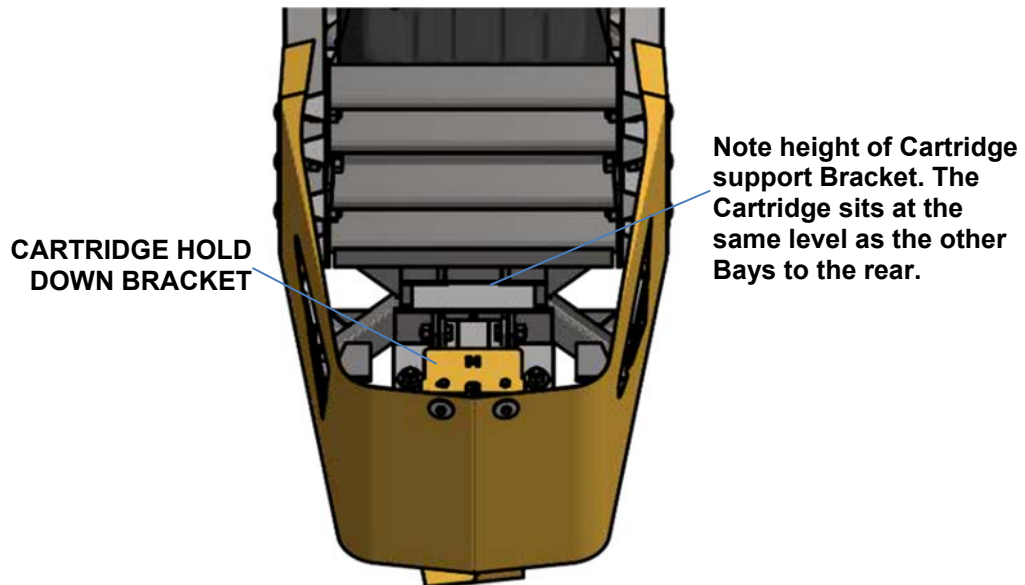

Figure 33

11) Checking the System Assembly

At this point recheck to ensure that all fasteners are properly tightened throughout the system (anchor bolts, etc.). See torque requirements below. Check all Fender Panels. If they do not fit tightly against the underlying Panel, system realignment may be necessary (Figure 34).



Warning	
Bolt Torque Requirements	
Anchor Studs – p. 16	
Critical Clearances	
Anchor Studs above nuts – p. 24, Figure 20	
Fender Panel Gap – .78" [20 mm] Figure 34	

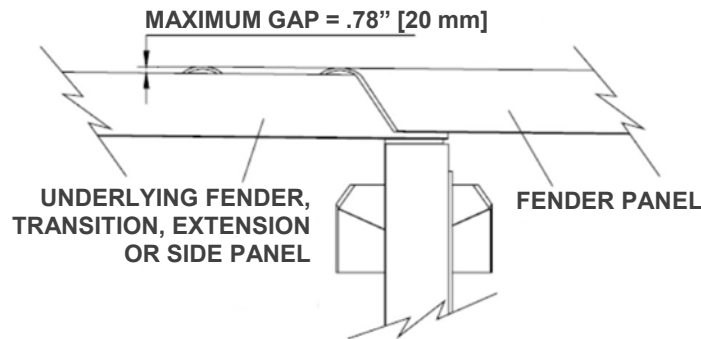

Figure 34
Fender Panel Gap

12) Cartridge Placement

The top surface of the Nose Cartridge should be horizontal. To complete the assembly of a QuadGuard® M10, place the appropriate Cartridge in each Bay and Nose section of the system. Type I Cartridges are placed toward the front (Nose) of the system; Type II Cartridges are placed toward the rear (Backup) of the system (p. 19).



Warning: Placing the wrong Cartridge in the Nose or Bay(s) could result in unacceptable crash performance per MASH criteria and cause serious injury or death to occupants and/or bystanders in the event of a vehicle impact.



Important: The QuadGuard® M10 is a six (6) Bay configuration.

QuadGuard® M10 24” Final Inspection Checklist

Site Location: _____

Date: _____

Inspector: _____

Refer to the QuadGuard® M10 24” manual and / or drawing package.

- Transition Panel fits for the offset (p. 11)
- Clearance of 30” behind rear Fender Panels for slide back (p. 14)
- Anchor nuts are torqued to manufacturer specification (p. 16)
- Top of Nose panels are 32 1/8” above concrete pad (p. 19)
- Cartridges are level and the same height in each Bay (p. 19)
- Correct Cartridge is placed in each Bay and pointing to front of system (p. 19)
- Cartridge Hold Down Bracket is secure and engaged with Nose Cartridge (p. 19)
- Every hole and slot in Backup and Monorail is anchored (pp. 22, 24)
- If no transition, check for narrow side panels at backup (p. 23)
- Anchor stud(s) are 1.5” maximum above the pad) (p. 24)
- Diaphragms attached to the Monorail guides (p. 25)
- Diaphragm Shims installed between Diaphragm & Monorail guides (p. 25)
- Each Fender Panel has a tension Die Spring (p. 27)
- Mushroom Washers lay flat in slots (p. 27)
- Monorail has End Cap attached (p. 28)
- Nose Cartridge is at the same height as Bay Cartridges (p. 30)
- Fender Panel gap is .78” [20 mm] for Narrow systems (p. 33)
- Bolts and nuts are properly tightened (p. 33)
- System is clear of debris

Maintenance and Repair

Inspection Frequency

Inspections for QuadGuard® M10 are recommended as needed based upon volume of traffic and impact history. Visual Drive-By Inspections are recommended at least once a month. Walk-Up Inspections are recommended at least once a year.

Visual Drive-By Inspection

- 1) Check to see if there is evidence of an impact. If so, perform a walk-up inspection.
- 2) Check to see if the Cartridges are properly seated on the Support Brackets. Any damaged Cartridges must be replaced.



Warning: See Cartridge placement instructions on page 19.

- 3) Be sure the Steel Nose is in place.
- 4) Note the location and condition of the QuadGuard® M10 and the date of visual drive-by inspection.

Walk-Up Inspection Checklist

- Clear and dispose of on-site debris.
- Clear and remove excessive dirt from around the Monorail and Diaphragm feet.
- Bolts are tight and rust free.
- Anchor bolts are securely anchored.
- Diaphragm Legs are straight.
- All Mushroom Washer Assemblies are properly seated.
- Fender Panels and Transition Panels should nest tightly against the system.
- Cartridges have not been damaged and are properly seated on their Support Brackets. To ensure intended speed characteristics, partially crushed Cartridges (due to low speed impacts) must be replaced.
- Make all necessary repairs as described above. See Post-Impact Instructions for more information on next page.
- To determine if a product should be replaced or is potentially reusable, a trained engineer experienced in highway products and directed by the DOT, or other appropriate local highway authority, must be consulted.

Post-Impact Instructions



Important: Trinity Highway makes no recommendation whether use or reuse of any part of the system is appropriate or acceptable following an impact. It is the sole responsibility of the local highway authority and its engineers to make that determination. It is critical that you inspect this product after assembly is complete to make certain that the instructions provided in this manual have been strictly followed.

- 1) Deploy appropriate traffic-control devices.
- 2) Check to see that all anchor bolts have remained firmly anchored in the roadway surface. Replace any that are loose, broken, or pulled out.

The proper performance of the system during an angle impact depends on the Monorail anchors being properly anchored.

- 3) Clear and dispose of any debris on the site.
- 4) Check the system to be certain that the Mushroom Washer Assemblies holding the Fender Panels together are still intact and that the system has not been deformed in a way that would prevent pulling it back to its original position.
- 5) Be sure that the Diaphragm Support Legs are all properly attached to the Monorail.



Caution: Use eye protection and gloves when refurbishing the Mushroom Washer Die Spring Assembly. Do not place fingers underneath an assembled Mushroom Washer. Parts may suddenly shift and fingers may be pinched. If the Die Spring is still under compression as the nut is nearing the end of the bolt, to prevent injury make sure that the Die Spring is restrained with a clamp so it does not suddenly release when the nut is removed from the Mushroom Washer Bolt.

- 6) Remove the Nose Assembly and attach a chain to the Pullout Brackets on the first Diaphragm (Figure 35). Attach both ends of chain to a heavy vehicle (such as a 1 ton pickup).



Warning: Stand clear in case chain breaks or becomes disconnected.

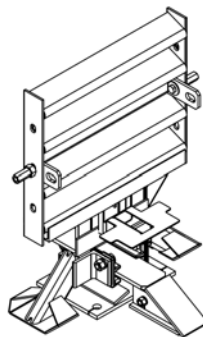

Figure 35
Pullout Brackets

Slowly pull the QuadGuard® M10 forward until the system reaches its original length. Have someone watch the system during repositioning to be certain previously undetected damage does not cause the Diaphragms to bind or pull out improperly.

- 7) Remove all crushed Cartridges from within the system.
- 8) Check to see that the Diaphragms are in usable condition. Diaphragms which are bowed or have bent legs must be replaced.
- 9) Check that the Fender Panels are properly attached with the Mushroom Washer Assemblies. Damaged Fender Panels and Transition Panels must be replaced.



Warning	
Fender Panel	Maximum gap allowed:
24" Wide Systems	.78" [20 mm]

- 10) Check the **gaps between Fender Panels**. The maximum gap allowed for these overlapping parts (including Fender Panels overlapping Panels behind the system) is .78" [20 mm].



Important: Ensure the Mushroom Washer Assemblies are torqued to the end of the threads. If the gaps between the Fender Panels are still too large, it may be necessary to replace bent parts.

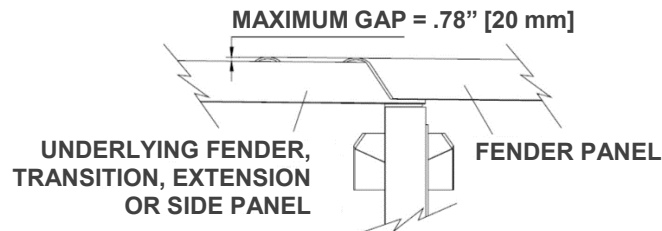

Figure 36
Fender Panel Gap

- 11) Replace all crushed Cartridges and damaged Cartridge Support Brackets. See Cartridge Placement on page 19.
- 12) Remove damaged Nose Assembly. Attach the new Nose to the first Diaphragm. See pages 30 - 32 and 47 for Nose attachment instructions.



Warning	
Bolt Torque Requirements	
Anchor Studs – p. 16	
Critical Clearances	
Anchor Studs above nuts – p. 24	
Fender Panel Gap– .78" [20 mm] Figure 36	

- 13) Check all bolts on the system to ensure they are adequately tight.
- 14) Check to be certain that the site is free from any debris.
- 15) The QuadGuard® M10 is now ready for use.

Parts Ordering Procedure & Drawings

Make a list of all damaged parts from the System Components section in this manual (p. 7 – 10). Answer the following questions in the spaces provided. This information is necessary to receive the proper parts.

QuadGuard® M10 Ordering Information Chart		
Description:	Choices	Fill in this section
Transition Panel Type? Side Panel and Transition Panel Types are on page 11. Include Transition options for both sides if necessary. How to Determine Left/Right is on page 20.	<ul style="list-style-type: none"> • Quad to W-Beam Guardrail • Quad to Thrie Beam Guardrail • Quad to Safety Shape Barrier • Quad to Single Slope Barrier • Quad to Vertical Concrete End Shoe • None 	

Parts List(s) & Quantities

PN	Description	Tension Strut Backup	
		6 Bay	3 Bay
118710	Adhesive, HY200, 330, Hilti	14	9
626055	Backup, TS, 24, QG, M10, W/Decals	1	1
004441	Bolt, GR, 5/8X5, A307	6	6
113518	Bolt, Hex, 1/4X3/4, G5	6	6
113555	Bolt, Hex, 3/4X2, G8	24	12
113596	Bolt, Hex, 3/8X1, G5	4	4
113660	Bolt, Hex, 5/8X3 1/2, G5	1	1
003400	Bolt, Rail, 5/8X2	24	12
626817	Bracket, Angle, 2X1, W/Holes	2	2
626815	Bracket, Cart Hold Down, QG M	1	1
626816	Bracket, Cart Support, Nose, QG M	1	1
605446	Bracket, Cartridge Supt, Dia, Folded, QG	12	6
605447	Bracket, Cartridge, Supt, TS B/U, QG	1	1
605535	Bracket, Pull-Out, QG	2	2
625647	Diaphragm, QG, 24, QG	6	3
608136	Endcap, Monorail	1	1
611266	Locking Bar, Cartridge Supt, QG	1	1
611368	Monorail Guide, QG	12	6
611375	Monorail, 2 Bays	1	1

PN	Description	Tension Strut Backup	
		6 Bay	3 Bay
611379	Monorail, 3 Bays	1	0
611669	Nose, L, Narrow, QGII, W/Logo	1	1
611680	Nose, R, Narrow, QGII, W/Logo	1	1
003704	Nut, Hex Heavy, 3/4	80	48
003354	Nut, Hex Heavy, 5/8	13	7
115946	Nut, Hex, 1/4	6	6
115960	Nut, Hex, 3/8	4	4
003340	Nut, Hex, Rail, 5/8	34	22
611832	Panel, Fender, QG	12	6
611898	Panel, Side, QG	2	2
627537	Pipe, 3/4 Schedule 80X3	6	6
116878	Screw, FL Hex Socket, 5/8X5	12	6
614062	Shim, 12GA X 3 5/8X8	12	6
117459	Spring, Die, 1 1/4 OD X 1 1/2	12	6
117542	Stud, 3/4X7, G5	56	36
626818	Washer, Bar, 10GAX2X14	2	2
118036	Washer, Flat, 3/8X1, G	4	4
118038	Washer, Flat, 3/8X2	2	2
003300	Washer, Flat, 5/8X1 3/4	12	6
118027	Washer, Flat, Heavy, 3/4X2	56	36
118089	Washer, Lock, 3/4	24	12
118100	Washer, Lock, 5/8	1	1
617045	Washer, Mushroom Forged, QG	12	6



Warning: Use only Trinity Highway parts that are specified herein for assembling, maintaining, or repairing the QuadGuard® M10. **Do not utilize or otherwise comingle parts from other systems even if those systems are other Trinity Highway systems.** Such configurations have not been tested, nor have they been deemed eligible for use. Assembly, maintenance, or repairs using unspecified parts or accessories is strictly prohibited.

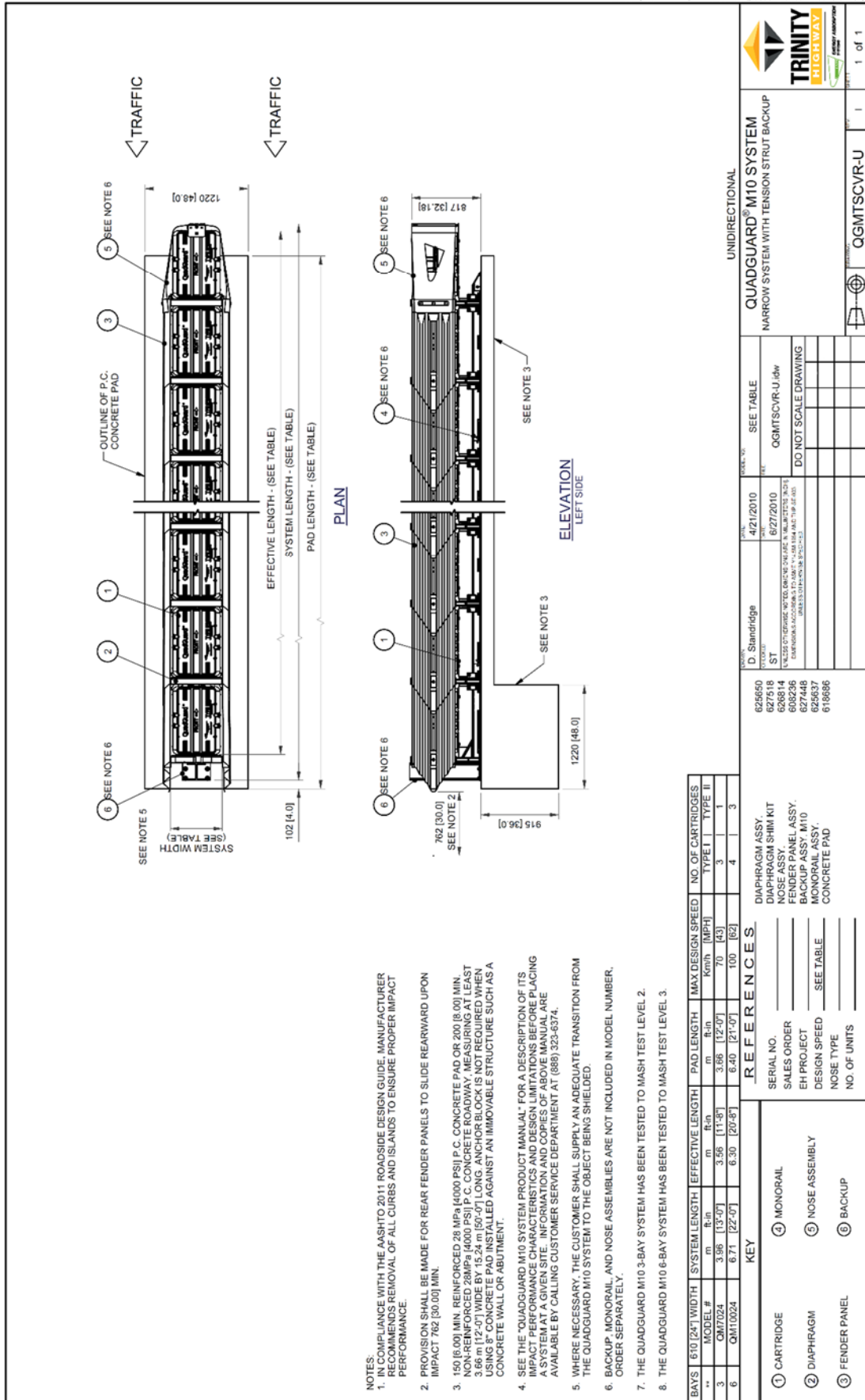

- NOTES:**
- IN COMPLIANCE WITH THE AASHTO 2011 ROADSIDE DESIGN GUIDE, MANUFACTURER RECOMMENDS REMOVAL OF ALL CURBS AND ISLANDS TO ENSURE PROPER IMPACT PERFORMANCE.
 - PROVISION SHALL BE MADE FOR REAR FENDER PANELS TO SLIDE REARWARD UPON IMPACT 762 [30.0] MIN.
 - 150 [6.00] MIN. REINFORCED 28 MPa [4000 PSI] P. C. CONCRETE PAD OR 200 [8.00] MIN. NON-REINFORCED 38MPa [4000 PSI] P. C. CONCRETE ROADWAY, MEASURING AT LEAST 150 [6.00] MIN. FROM THE END OF THE CONCRETE ROADWAY. REINFORCEMENT IS NOT REQUIRED IF THE USING P.C. CONCRETE PAD IS INSTALLED AGAINST AN IMMOVABLE STRUCTURE SUCH AS A CONCRETE WALL OR ABUTMENT.
 - SEE THE "QUADGUARD M10 SYSTEM PRODUCT MANUAL" FOR A DESCRIPTION OF ITS IMPACT PERFORMANCE CHARACTERISTICS AND DESIGN LIMITATIONS BEFORE PLACING A SYSTEM AT A GIVEN SITE. INFORMATION AND COPIES OF ABOVE MANUAL ARE AVAILABLE BY CALLING CUSTOMER SERVICE DEPARTMENT AT (888)323-8374.
 - WHERE NECESSARY, THE CUSTOMER SHALL SUPPLY AN ADEQUATE TRANSITION FROM THE QUADGUARD M10 SYSTEM TO THE OBJECT BEING SHIELDED.
 - BACKUP, MONORAIL, AND NOSE ASSEMBLIES ARE NOT INCLUDED IN MODEL NUMBER, ORDER SEPARATELY.
 - THE QUADGUARD M10 3-BAY SYSTEM HAS BEEN TESTED TO MASH TEST LEVEL 2.
 - THE QUADGUARD M10 6-BAY SYSTEM HAS BEEN TESTED TO MASH TEST LEVEL 3.

BAYS	6'0" [24"] WIDTH	SYSTEM LENGTH	EFFECTIVE LENGTH	PAD LENGTH	MAX DESIGN SPEED	NO. OF CARTRIDGES
MODEL #	m	ft-in	m	ft-in	km/h [MPH]	TYPE I TYPE II
3	3.96 [13'-0"]	3.96 [13'-0"]	3.96 [13'-0"]	70 [45]	100 [65]	3 1
6	6.71 [22'-0"]	6.71 [22'-0"]	6.30 [20'-8"]	8.40 [27'-0"]	100 [65]	4 3

REFERENCES

SERIAL NO.	DIAPHRAGM ASSY.
625650	DIAPHRAGM SHIM KIT
627918	FENDER PANEL ASSY.
608236	BACKUP ASSY. M10
627448	MONORAIL ASSY.
625637	CONCRETE PAD
619686	

KEY

① CARTRIDGE	④ MONORAIL
② DIAPHRAGM	⑤ NOSE ASSEMBLY
③ FENDER PANEL	⑥ BACKUP

NO.	DESCRIPTION	DATE	BY
1	D. Slanbridge	4/21/2010	ST
2	ST	6/27/2010	ST

DO NOT SCALE DRAWING

UNIDIRECTIONAL

QUADGUARD® M10 SYSTEM

NARROW SYSTEM WITH TENSION STRUT BACKUP

TRINITY HIGHWAY

© 2010-2020 Trinity Highway Products, LLC. All rights reserved.

QuadGuard® M10 w/ Tension Strut Backup QGMTSCVR-U

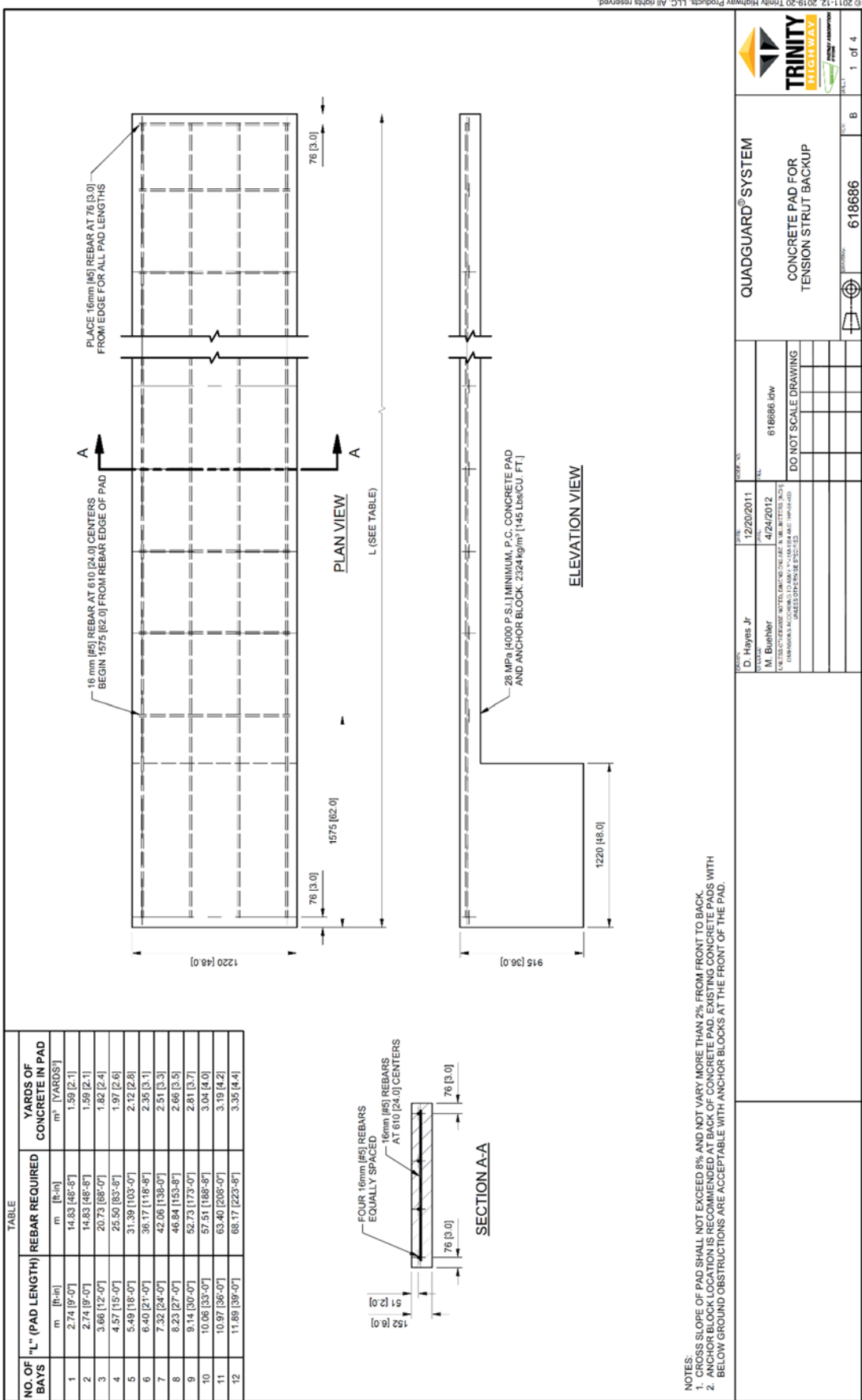

Concrete Pad 618686

PARTS LIST

ITEM	DESCRIPTION
1	BACKUP T.S.OG WIDECALS
2	PANEL SIDE.OG
3	ANCHOR KIT.HILT
4	NUT.HX.5/8.G.RAIL
5	BOLT.RAIL.5/8X2.G
6	BRACKET.CARTRIDGE SUPT.TS.BULOG
7	LOCKING BAR.CARTRIDGE SUPT.OG

TABLE

SYSTEM	WIDTH	7" ANCHORS	18" ANCHORS	NO ANCHORS
CG.M10	24"	626059	627447	627448
QG.OGII.OG.HS	24"	604570	626516	627450
QG.OGII.OG.HS	30"	604574	626517	627451
QG.OGII.OG.HS	36"	604584	626518	627452
QG.OGII.OG.HS	48"	604590	626519	627453

NOTE:
 1. WHEN TRANSITIONING QUADGUARD SYSTEM TO EXISTING BARRIER, REFER TO THE TRANSITION ASSEMBLY DRAWINGS FOR PROPER USE OF SIDE PANEL, PART NO. 611888 (ITEM 2).

DESIGNER R. VENZON	DATE 2/12/2020	CHECKER (blank)	DATE (blank)	SEE TABLE 627448.dwg
DESIGNED BY B. ECKERT	DATE 2/14/2020	DO NOT SCALE DRAWING		
TRINITY HIGHWAY PRODUCTS, L.L.C. 1100 W. 10TH AVENUE, SUITE 100, DENVER, CO 80202 PHONE: (303) 733-8800 FAX: (303) 733-8801				

QUADGUARD® SYSTEM
 BACKUP ASSY, TS, QG

627448

Tension Strut Backup 627448

1 of 1

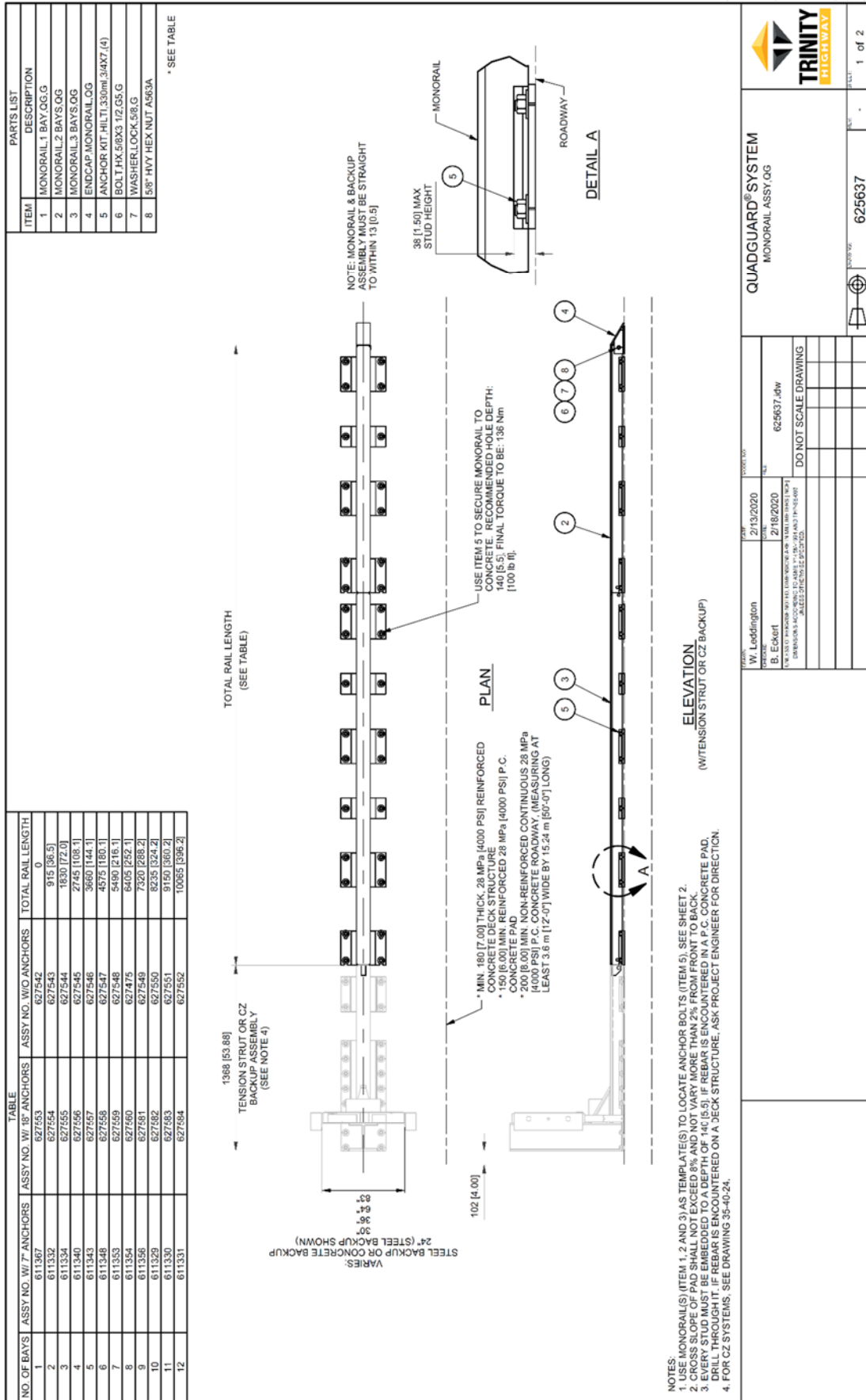

NOTES:
 1. USE MONORAIL (S) ITEM 1, 2 AND 3) AS TEMPLATE(S) TO LOCATE ANCHOR BOLTS (ITEM 5). SEE SHEET 2.
 2. REBAR SHALL BE ENBEDDED TO A DEPTH OF 140 (5.5) IF REBAR IS ENCOUNTERED IN A P.C. CONCRETE PAD.
 3. EVERY STUD MUST BE ENBEDDED TO A DEPTH OF 140 (5.5) IF REBAR IS ENCOUNTERED IN A P.C. CONCRETE PAD.
 4. FOR CZ SYSTEMS, SEE DRAWING 35-40-24.

		QUADGUARD[®] SYSTEM MONORAIL ASSY, O.G	
DESIGNED BY	W. Leedington	DATE	2/13/2020
CHECKED BY	B. Eckert	DATE	2/18/2020
PROJECT NO.	625637.dwg	SCALE	DO NOT SCALE DRAWING
THIS SHEET IS PART OF A PROJECT AND SHALL BE USED ONLY FOR THE PROJECT AND SHALL NOT BE REPRODUCED OR TRANSMITTED IN ANY FORM OR BY ANY MEANS, ELECTRONIC OR MECHANICAL, INCLUDING PHOTOCOPYING, RECORDING, OR BY ANY INFORMATION STORAGE AND RETRIEVAL SYSTEM.			
		PROJECT NO.	625637
		SHEET	1 of 2

Monorail Assembly 625637

NOTE:
1. QUADGUARD II REQUIRES THE SHIM KIT, SEE 814050.

ITEM	STOCK NO.	DESCRIPTION	QTY.
1	SEE TABLE	SEE TABLE	1
8	611368	MONORAIL GUIDE.OG.G	2
9	003704	3/4" HXY HEX NUT A563 DH	4
10	113655	BOLT,HX,3/4X2,GR.G	4
11	118089	WASHER,LOCK,3/4,G	4
12	605446	BRACKET,CARTRIDGE SUPT,DIA,FOLDED,OG.G	2

ASSY. NO.	ITEM 1	DESCRIPTION	WIDTH
625650	625647	DIAPHRAGM,QB,24,OG.G	610 [24.00]
625651	625648	DIAPHRAGM,QB,30,OG.G	760 [30.00]
625652	625649	DIAPHRAGM,QB,36,OG.G	915 [36.00]
606810	607638	DIAPHRAGM,QB,48,OG.G	1219 [48.00]

REVISED BY	W. Leedington	DATE	4/13/2016
DESIGNED BY	A. Van Brocklin	DATE	4/28/2016
UNLESS OTHERWISE NOTED, ALL DIMENSIONS ARE IN INCHES (R/O 1/16)			
DIMENSIONS IN PARENTHESIS ARE UNFINISHED DIMENSIONS.			
DO NOT SCALE DRAWING			

DIAPHRAGM ASSY, QB, 24"

625650

1 of 3

Diaphragm Assembly 625650

PARTS LIST	
ITEM	DESCRIPTION
1	SHIM, G

TABLE	
KIT	THICKNESS
B14050	12 GA

QUADGUARD® FAMILY				
SHIM KIT				
627518				

TRINITY	TRIGHWAY			
----------------	-----------------	--	--	--

Shim Kit 627518

PARTS LIST			
ITEM	STOCK NO.	DESCRIPTION	QTY.
1	611832	PANEL,FENDER,OG	1
2	003400	BOLT,FRML,5/8X2,G	2
3	003340	5/8"GR HEX NUT	2
4	617045	WASHER,MUSHROOM,FORGED,OG,G	1
5	116878	SCREW,FL,5/8X5,GR,G,HEX SOCKET	1
6	115970	NUT,HX,5/8,G	1
7	003300	WASHER,FLAT,5/8 X 1 3/4, G	1
8	117459	SPRING,DIE,1 1/4 CDXSP1BX1 1/2,G	1

TIGHTEN NUT UNTIL IT REACHES END OF THREADS

SEE NOTE 2

UNDERLYING PANEL (SEE NOTE 1)

NOTES:
 1. UNDERLYING PANEL IS ANOTHER FENDER PANEL. IN THE CASE OF THE LAST FENDER PANEL, THE UNDERLYING PANEL IS AN UNDERLAP SIDE PANEL, EXTENSION PANEL, OR TRANSITION PANEL.
 2. THERE IS TO BE A .20 / .787" MAX. GAP BETWEEN ANY FENDER PANEL AND THE UNDERLYING PANEL.

DESIGNER: J. Espinoza DATE: 5/21/1996 CHECKED: J. Marchado DATE: 5/21/1996 APPROVED: J. Marchado DATE: 5/21/1996 PROJECT: 608236.dwg DO NOT SCALE DRAWING	QUADGUARD® FENDER PANEL, ASSY, OG	PART NO. 608236 REV. K SHEET 1 of 1
--	--------------------------------------	---

PARTS LIST	
ITEM	DESCRIPTION
1	NOSE L, NARROW, QG11, W/LOGO
2	NOSE R, NARROW, QG11, W/LOGO
3	BRACKET, CART SUPPORT, NOSE, QG, M
4	BOLT, HK, 1/4X3/4, G5, G
5	NUT, HK, 1/4, G
6	NUT, HK, 5/8, G, RAIL
7	BRACKET, CART HOLD DOWN, QG, M
8	BRACKET, ANGLE, 2X1, W/HOLES
9	WASHER, FLAT, 3/8X1, G
10	NUT, HK, 3/8, G
11	BOLT, HK, 3/8X1, G5, G
12	WASHER, FLAT, 3/8X2, G
13	BRACKET, PULL-OUT, QG
14	PIPE, 3/4 SCH, 80X3
15	5/8"X5" GR BOLT, A307
16	WASHER, BAR, 10GA, 2X14, SLOTS

TABLE	
ASSEMBLY	FINISH
617385	GALVANIZED
617424	YELLOW
617425	BLACK

QUADGUARD [®] M10 SYSTEM		NOSE ASSY, NARROW, QGM	
DATE	11/19/2019	DATE	11/19/2019
DESIGNED BY	D. Kohfeld	DATE	11/19/2019
CHECKED BY	B. Eckert	DATE	1/7/2020
<small>UNLESS OTHERWISE NOTED, ALL DIMENSIONS ARE IN INCHES (MM). DIMENSIONS IN PARENTHESES ARE METRIC EQUIVALENTS. UNLESS OTHERWISE SPECIFIED, ALL DIMENSIONS ARE IN INCHES (MM). DIMENSIONS IN PARENTHESES ARE METRIC EQUIVALENTS.</small>			
DO NOT SCALE DRAWING			
PART NUMBER: 626814, REV: 00 TITLE: NOSE ASSY, NARROW, QGM DRAWN BY: D. KOHFELD CHECKED BY: B. ECKERT DATE: 11/19/2019 SCALE: 1:1			

626814	1 of 1
--------	--------

Nose Assembly 626814



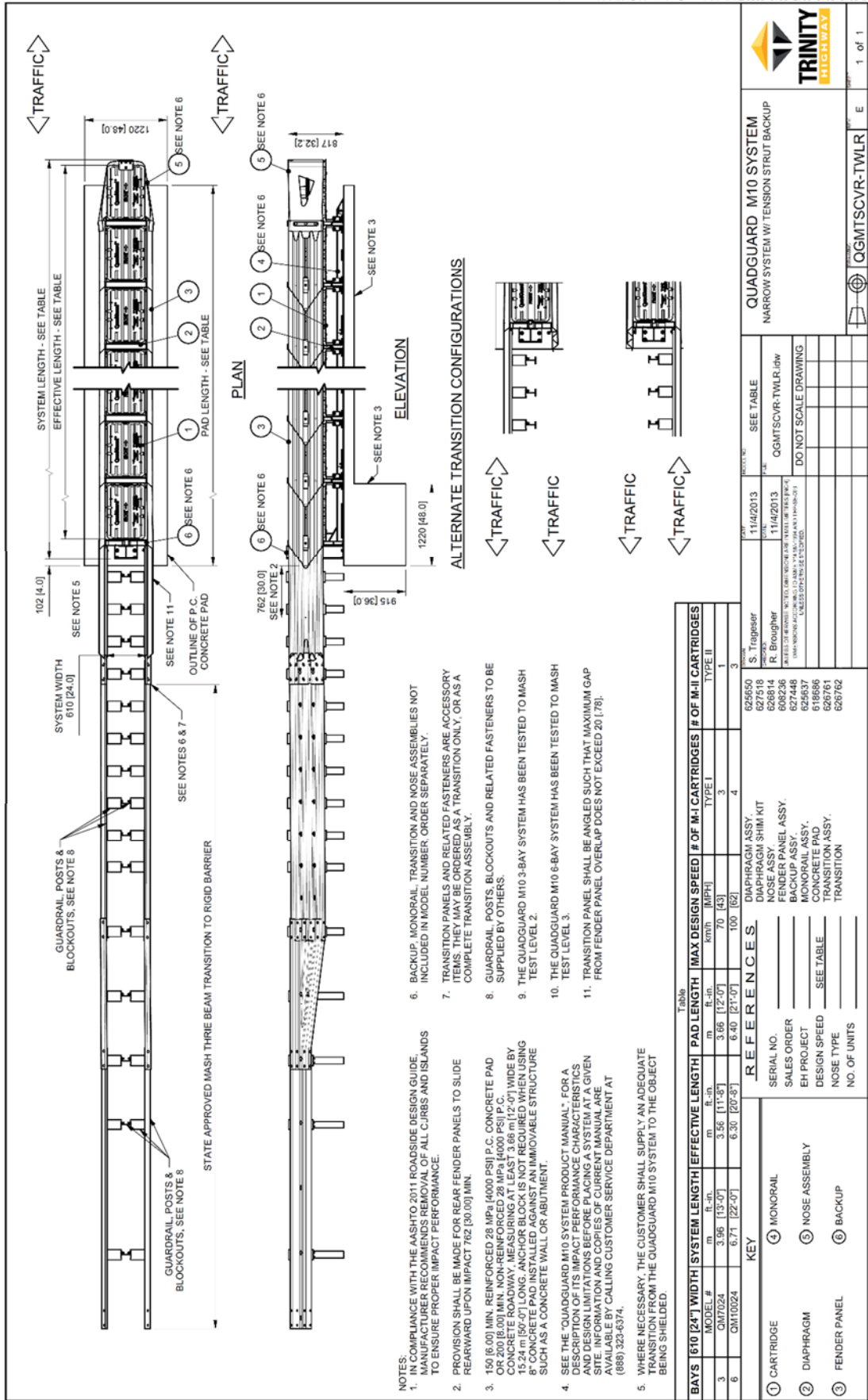

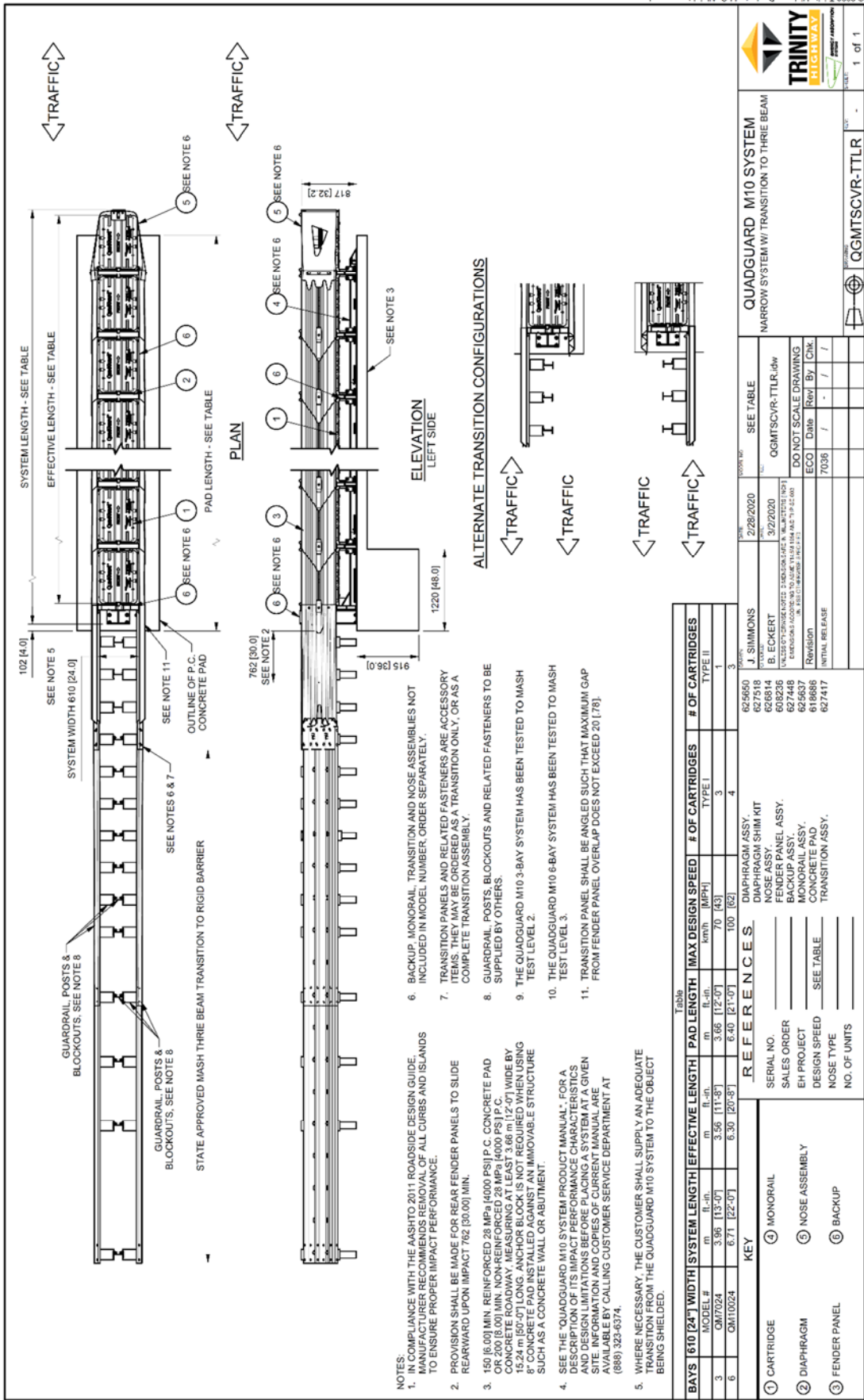

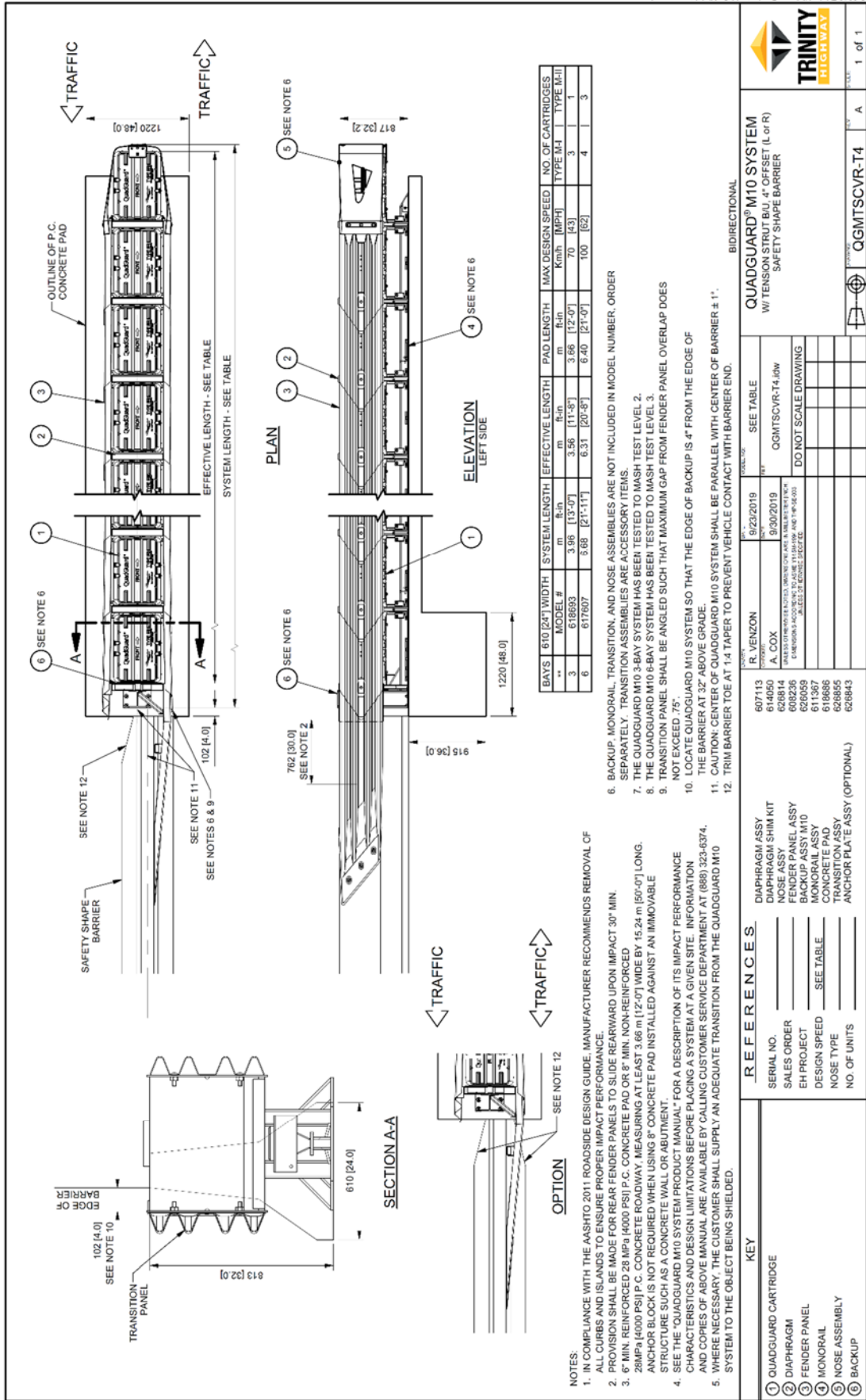

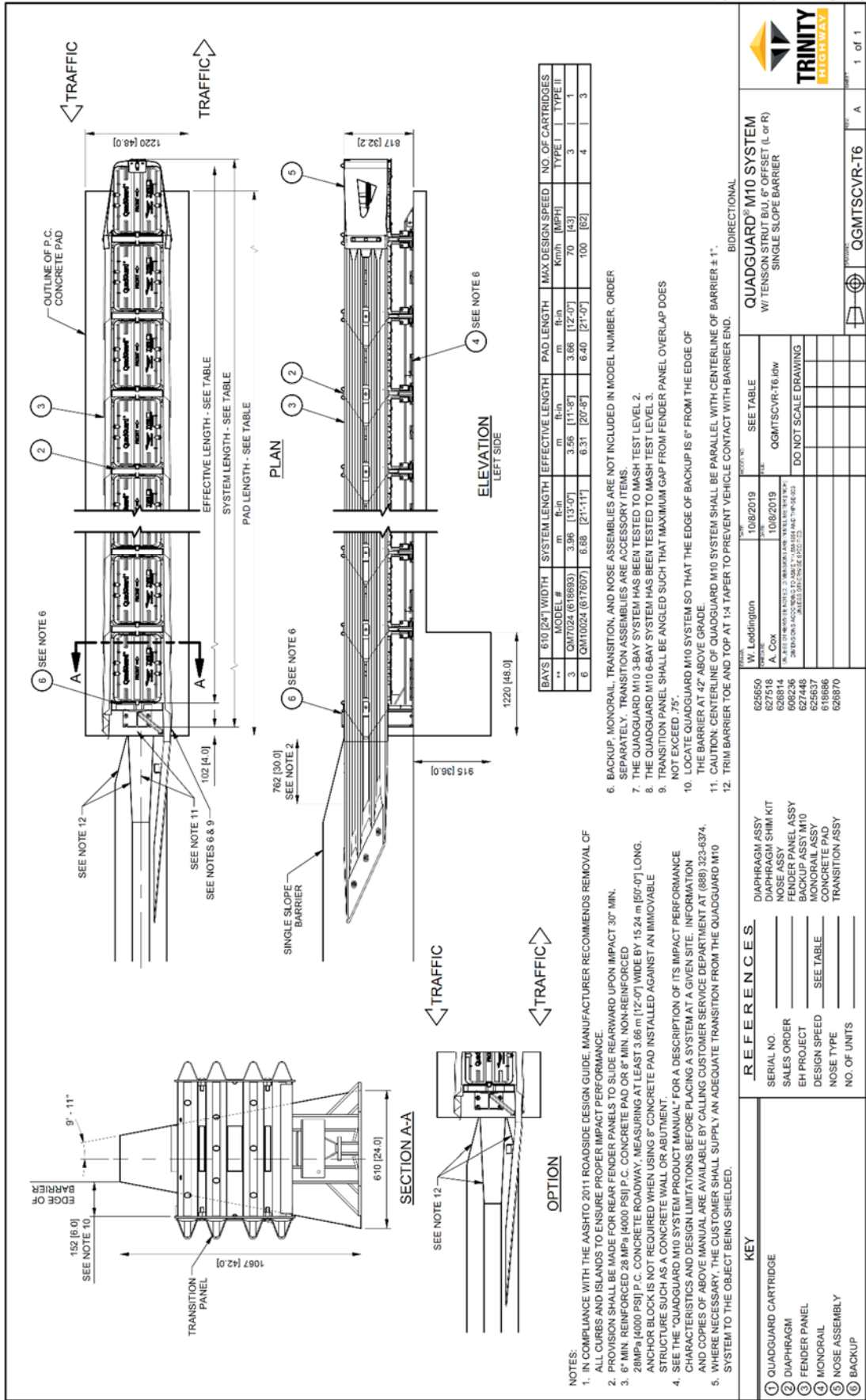

QuadGuard® M10 24" Transition to Single Slope QGMTSCVR-T6

REFERENCES

1. QUADGUARD CARTRIDGE
 2. DIAPHRAGM
 3. FENDER PANEL
 4. MONORAIL
 5. NOSE ASSEMBLY
 6. BACKUP

KEY

DIAPHRAGM ASSY
 DIAPHRAGM SHIM KIT
 NOSE ASSY
 FENDER PANEL ASSY
 BACKUP ASSY M10
 MONORAIL ASSY
 CONCRETE PAD
 TRANSITION ASSY

REFERENCES

W. Liddington
 A. Cook
 DATE: 10/8/2019
 DATE: 10/8/2019
 DATE: 10/8/2019

SEE TABLE

QGMTSCVR-T6.iw
 DO NOT SCALE DRAWING

QUADGUARD® M10 SYSTEM
 W/ TENSION STRUT BUJ. 6" OFFSET (L or R)
 SINGLE SLOPE BARRIER

QGMTSCVR-T6

1 of 1

© 2019 Trinity Highway Products, LLC. All rights reserved.

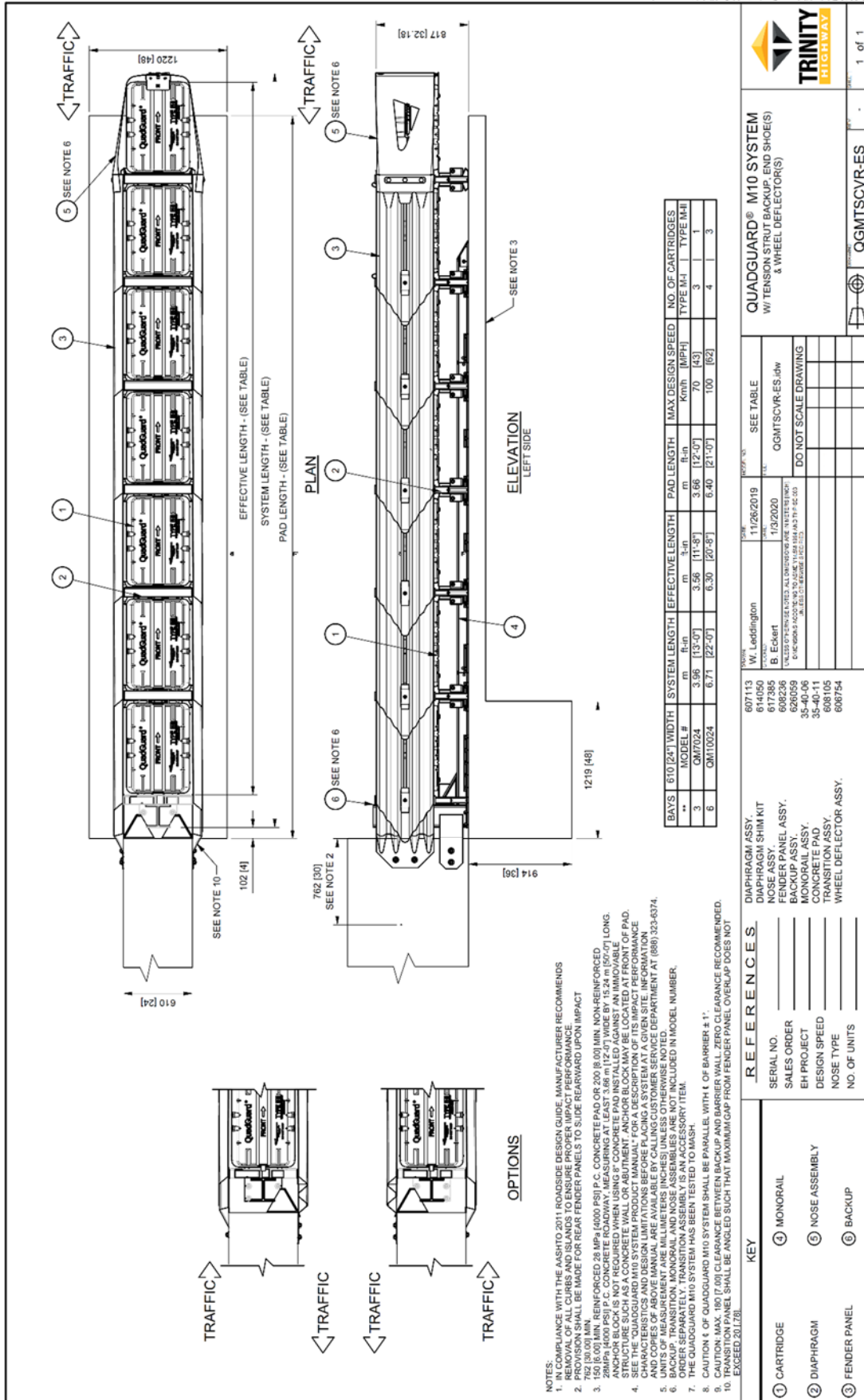

NOTES:

- IN COMPLIANCE WITH THE AASHTO 2011 TRANSITION DESIGN GUIDE, MANUFACTURER RECOMMENDS 100% CONCRETE BACKUP FOR ALL TRANSITION PANELS. ALL TRANSITION PANELS SHALL BE MADE FOR REAR FENDER PANELS TO SLIDE REARWARD UPON IMPACT.
- 762 [30] MIN. UNREINFORCED OR 1000 [39] MIN. REINFORCED CONCRETE PAD OR 200 [8] MIN. NON-REINFORCED ANCHOR BLOCK IS NOT REQUIRED WHEN USING 8" CONCRETE PAD INSTALLED AGAINST AN IMMOVABLE STRUCTURE SUCH AS A CONCRETE WALL OR ABUTMENT. ANCHOR BLOCK MAY BE LOCATED AT FRONT OF PAD.
- CHARACTERISTICS AND DESIGN LIMITATIONS BEFORE PLACING SYSTEM AT JOBSITE. INFORMATION AND COPIES OF ABOVE MANUAL ARE AVAILABLE BY CALLING CUSTOMER SERVICE DEPARTMENT AT (888) 333-6374.
- UNITS OF MEASUREMENT ARE MILLIMETERS (INCHES) UNLESS OTHERWISE NOTED.
- ORDER SEPARATELY. TRANSITION ASSEMBLY IS AN ACCESSORY ITEM.
- THE QUADGUARD M10 SYSTEM HAS BEEN TESTED TO MASH.
- CAUTION: 4" OF QUADGUARD M10 SYSTEM SHALL BE PARALLEL WITH 1" OF BARRIER ± 1".
- CAUTION: MAX. 180 [7.09] CLEARANCE BETWEEN BACKUP AND BARRIER WALL. ZERO CLEARANCE RECOMMENDED.
- TRANSITION PANEL SHALL BE ANGLED SUCH THAT MAXIMUM GAP FROM FENDER PANEL OVERLAP DOES NOT EXCEED 20 [0.78].

REFERENCES:

KEY	DESCRIPTION
①	CARTRIDGE
②	DIAPHRAGM
③	FENDER PANEL
④	MONORAIL
⑤	NOSE ASSEMBLY
⑥	BACKUP

QUADGUARD® M10 SYSTEM
W/ TENSION STRUT BACKUP, END SHOE(S) & WHEEL DEFLECTOR(S)

DATE	BY	DESCRIPTION
11/26/2019	W. Leaddington	REVISED
1/9/2020	B. Ebert	REVISED

DO NOT SCALE DRAWING

TRINITY HIGHWAY

1 of 1

QGMTSCVR-ES

QuadGuard® M10 24" Transition to Vertical Barrier QGMTSCVR-ES

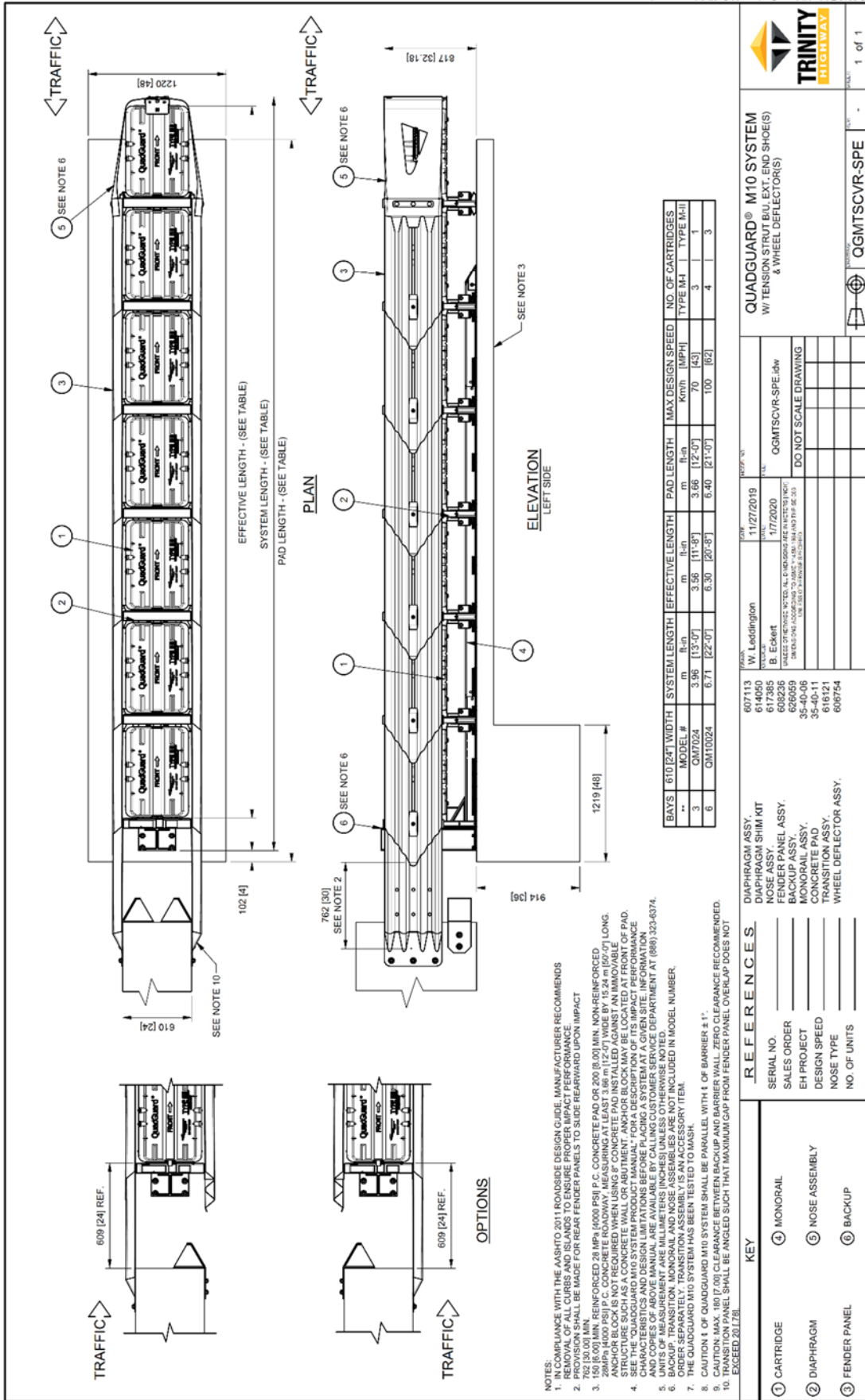

NOTES:

- IN COMPLIANCE WITH THE ASHTO 2011 ROADSIDE DESIGN GUIDE, MANUFACTURER RECOMMENDS THE USE OF CONCRETE FENDER PANELS TO SLIDE REARWARD UPON IMPACT.
- PROVISION SHALL BE MADE FOR REAR FENDER PANELS TO SLIDE REARWARD UPON IMPACT.
- 150 [6.00] MIN. REINFORCED 28 MPa [4000 PSI] P.C. CONCRETE PAD OR 200 [8.00] MIN. NON-REINFORCED 28 MPa [4000 PSI] P.C. CONCRETE PAD SHALL BE INSTALLED AGAINST AN IMMOVABLE ANCHOR BLOCK IS NOT REQUIRED WHEN USING P.C. CONCRETE PAD.
- STRUCTURE SUCH AS A CONCRETE WALL OR ABUTMENT ANCHOR BLOCK MAY BE LOCATED AT FRONT OF PAD. SEE THE "QUADGUARD M10 SYSTEM PRODUCT MANUAL" FOR A DESCRIPTION OF ITS IMPACT PERFORMANCE. THE "QUADGUARD M10 SYSTEM PRODUCT MANUAL" IS AVAILABLE AT www.trinityhighway.com AND COPIES OF ABOVE MANUAL ARE AVAILABLE BY CALLING CUSTOMER SERVICE DEPARTMENT AT (888) 323-6374.
- UNITS OF MEASUREMENT ARE MILLIMETERS (INCHES) UNLESS OTHERWISE NOTED.
- BACKUP, TRANSITION, MONORAIL AND NOSE ASSEMBLIES ARE NOT INCLUDED IN MODEL NUMBER. THE QUADGUARD M10 SYSTEM HAS BEEN TESTED TO WASH.
- CAUTION 1 OF QUADGUARD M10 SYSTEM SHALL BE PARALLEL WITH 1 OF BARRIER ±1".
- CAUTION: MAX. 180 [7.00] CLEARANCE BETWEEN BACKUP AND BARRIER WALL. ZERO CLEARANCE RECOMMENDED. TRANSITION PANEL SHALL BE ANGLED SUCH THAT MAXIMUM GAP FROM FENDER PANEL OVERLAP DOES NOT EXCEED 20 [0.78].

KEY	REFERENCES
① CARTRIDGE	DIAPHRAGM ASSY.
② DIAPHRAGM	NOSE ASSEMBLY KIT
③ FENDER PANEL	NOSE ASSEMBLY
	FENDER PANEL ASSY.
	BACKUP ASSY.
	MONORAIL ASSY.
	CONCRETE PAD
	TRANSITION ASSY.
	WHEEL DEFLECTOR ASSY.

W. Laddington	DATE	11/27/2019
B. Eckert	DATE	1/7/2020
PROJECT NO. QGMTSCVR-SPE.dwg		
DO NOT SCALE DRAWING		
QUADGUARD® M10 SYSTEM		
W/ TENSION STRUT BU, EXT. END SHOE(S) & WHEEL DEFLECTOR(S)		
SCALE: 1" = 1'-0"		
SHEET NO. 1 of 1		

QuadGuard® M10 24" Transition to Vertical Barrier, Extended QGMTSCVR-SPE

NOTES:



TRINITY

HIGHWAY

Ahead of the Curve[®]

For more complete information on Trinity Highway products and services, visit us on the web at www.trinityhighway.com. Materials and specifications are subject to change without notice. Please contact Trinity Highway to confirm that you are referring to the most current instructions.

www.trinityhighway.com

888.323.6374 (USA)

+1 214.589.8140 (International)