

QuadGuard®

Product Description Manual

Part No. 619185B

Created May 2013



TRINITY
HIGHWAY PRODUCTS
ENERGY ABSORPTION SYSTEMS

QuadGuard®

Product Description Manual



Important: These instructions are to be used only in conjunction with the assembly, maintenance, and repair of the specified QuadGuard® system. These instructions are for standard assembly specified by the appropriate highway authority only. In the event the specified system assembly, maintenance, or repair would require a deviation from standard assembly parameters, contact the appropriate highway authority engineer. This system has been accepted by the Federal Highway Administration for use on the national highway system under strict criteria utilized by that agency. Energy Absorption Systems representatives are available for consultation if required.

This Manual must be available to the worker overseeing and/or assembling the product at all times. For additional copies, contact Energy Absorption Systems at (888) 323-6374 or download from websites below.

The instructions contained in this Manual supersede all previous information and Manuals. All information, illustrations, and specifications in this Manual are based on the latest QuadGuard® system information available to Energy Absorption Systems at the time of printing. We reserve the right to make changes at any time. Please contact Energy Absorption Systems to confirm that you are referring to the most current instructions.

Table of Contents

Customer Service Contacts	3
Important Introductory Notes	3
Recommended Safety Rules for Assembly	4
Safety Symbols	5
Warnings and Cautions.....	5
Limitations and Warnings.....	6
System Overview	7
QuadGuard® System Criteria	9
QuadGuard® CZ Design Criteria	14
QuadGuard® and QuadGuard® CZ Foundation/Anchoring	16
Site Preparation/Foundation	18
Recommended Tools.....	19
Transitioning	21
Transition Panel Types	22
Life Expectancy.....	23
QuadGuard® w/ Tension Strut Backup.....	24
QuadGuard® w/ Concrete Backup	25
QuadGuard® 69" or 90" System w/ Tension Strut Backup	26
QuadGuard® 69" or 90" System w/ Concrete Backup	27
QuadGuard® 120" System w/ Tension Strut Backup	28
QuadGuard® CZ for Construction Zones	29
QuadGuard® CZ System on a Plate.....	30
QuadGuard® Concrete Pad for Tension Strut Backup	31
QuadGuard® Optional 8" Concrete Pad for Tension Strut Backup	32
QuadGuard® Backup Assembly, TS	33
QuadGuard® Concrete Pad for Concrete Backup	34
QuadGuard® Concrete Backup on Grade	35
QuadGuard® Concrete Backup on Existing Concrete Structure	36
QuadGuard® Backup Assembly, Concrete	37
QuadGuard® Concrete Pad, CZ.....	38
QuadGuard® Monorail Assembly	39
QuadGuard® Diaphragm Assembly	42
QuadGuard® Fender Panel Assembly	43
QuadGuard® System Nose Assembly.....	44
QuadGuard® Tension Strut Backup Assembly (Wide).....	45
QuadGuard® Concrete Pad & Backup (Wide).....	46
QuadGuard® Concrete Pad & Backup on Grade (69").....	47
QuadGuard® Concrete Pad & Backup on Grade (90").....	48
QuadGuard® Backup Assembly, Concrete (Wide).....	49
QuadGuard® Diaphragm Assembly (Wide).....	50
QuadGuard® Fender Panel Assembly (Wide).....	52
QuadGuard® Nose Assembly (Wide).....	53
QuadGuard® CZ Anchor/Lifting Kit (3-9 Bays).....	54
QuadGuard® PCMB Anchor Assembly	56
QuadGuard® End Shoe Assembly	57
QuadGuard® 4" Offset Transition Assembly	58
QuadGuard® Quad-Beam to W-Beam Transition Assembly.....	59
QuadGuard® Quad-Beam to Thrie-Beam Transition Assembly	60

Customer Service Contacts

Energy Absorption Systems (a Trinity Highway Products company) is committed to the highest level of customer service. Feedback regarding the QuadGuard® system, its assembly procedures, supporting documentation, and performance is always welcome. Additional information can be obtained from the contact information below:

Energy Absorption Systems:

Telephone:	(888) 323-6374 (USA Only) (214) 589-8140 (USA or International)
E-mail:	customerservice@energyabsorption.com
Internet: Energy Absorption Systems Trinity Highway Products, LLC	http://www.energyabsorption.com http://www.highwayguardrail.com

Important Introductory Notes

Proper assembly of the QuadGuard® system is essential to achieve performance of the system under appropriate federal and state criteria. These instructions should be read in their entirety and understood before assembling the QuadGuard® system. These instructions are to be used only in conjunction with the assembly of the QuadGuard® system and are for standard assemblies only as specified by the applicable highway authority. In the event your system assembly requires or involves deviation from standard parameters or, during the assembly process a question arises, please contact the appropriate highway authority that specified this system at this particular location for guidance. Energy Absorption Systems is available for consultation with that agency. These instructions are intended for an individual who is qualified to both read and accurately interpret them as written. They are intended for the individual who is experienced and skilled in the assembly of highway products which are specified and selected by the highway authority.

A set of product drawings will be supplied by Energy Absorption Systems. The drawings will be for each section of the assembly. These drawings should be reviewed and studied thoroughly by a qualified individual who is skilled in interpreting them before the start of any assembly.

If you need additional information, or have questions about the QuadGuard system, please contact the highway authority that has planned and specified this assembly and, if needed, contact Energy Absorption System Customer Service Department.



Important: Read safety instructions thoroughly and follow the assembly directions and suggested safe practices before assembling, maintaining, or repairing QuadGuard® system. Failure to follow this warning can result in serious injury or death to workers and/or bystanders. It further compromises the acceptance of this system by the FHWA. Please keep these instructions for later use.



Warning: Ensure that all of the QuadGuard® system Warnings, Cautions, and Important Statements within the QuadGuard® Manual are completely followed. Failure to follow this warning could result in serious injury or death in the event of a collision.

Recommended Safety Rules for Assembly

*** Important Safety Instructions ***

This Manual must be kept in a location where it is readily available to persons who assemble, maintain, or repair the QuadGuard® system. Additional copies of this Manual are available from Energy Absorption Systems by calling (888) 323-6374. Please contact Energy Absorption Systems if you have any questions concerning the information in this Manual or about the QuadGuard® system. This Manual may also be downloaded directly from the websites indicated below.

Always use appropriate safety precautions when operating power equipment, mixing chemicals, moving heavy equipment or QuadGuard® system components. Gloves, safety goggles, safety toe shoes, and back protection should be used.

Safety measures incorporating traffic control devices specified by the highway authority must be used to provide safety for personnel while at the assembly, maintenance, or repair site.

Safety Symbols

This section describes the safety symbols that appear in this QuadGuard® Manual. Read the Manual for complete safety, assembly, operating, maintenance, repair, and service information.

<u>Symbol</u>	<u>Meaning</u>
---------------	----------------



Safety Alert Symbol: Indicates Danger, Warning, or Caution. Failure to read and follow the Danger, Warning, Safety, or Caution indicators could result in serious injury or death to the workers and/or bystanders.

Warnings and Cautions

Read all instructions before assembling, maintaining, or repairing the QuadGuard® system.



Warning: Do not assemble, maintain, or repair the QuadGuard® system until you have read this Manual thoroughly and completely understand it. Ensure that all Warnings, Cautions, and Important Statements within the Manual are completely followed. Please call Energy Absorption Systems at (888) 323-6374 if you do not understand these instructions. Failure to follow this warning could result in serious injury or death in the event of a collision.



Warning: Safety measures incorporating appropriate traffic control devices specified by the highway authority must be used to protect all personnel while at the assembly, maintenance, or repair site. Failure to follow this warning could result in serious injury or death in the event of a collision.



Warning: Use only Energy Absorption Systems parts that are specified herein for the QuadGuard® system for assembling, maintaining, or repairing QuadGuard® system. Do not utilize or otherwise comingle parts from other systems even if those systems are other Energy Absorption Systems or Trinity Highway Products systems. Such configurations have not been tested nor have they been accepted for use. Assembly, maintenance, or repairs using unspecified parts or accessories is strictly prohibited. Failure to follow this warning could result in serious injury or death in the event of a vehicle impact with an UNACCEPTED system.



Warning: Do NOT modify the QuadGuard® system in any way. Failure to follow this warning could result in serious injury or death in the event of a collision.



Warning: Ensure that the QuadGuard® system and delineation used meet all federal, state, specifying agency, and local specifications. Failure to follow this warning could result in serious injury or death in the event of a collision.



Warning: Ensure that your assembly meets all appropriate Manual on Uniform Traffic Control Devices (MUTCD) and local standards. Failure to follow this warning could result in serious injury or death in the event of a collision.

Limitations and Warnings

Energy Absorption Systems, in compliance with the National Cooperative Research Highway Program 350 (NCHRP Report 350) "Recommended Procedures for the Safety Performance of Highway Safety Features", contracts with FHWA approved testing facilities to perform crash tests, evaluation of tests, and submittal of results to the Federal Highway Administration for review.

The QuadGuard[®] system has been approved by FHWA as meeting the requirements and guidelines of NCHRP Report 350 TL-2 (3 bay system) and TL-3 (6 bay system). These tests, typically evaluate product performance by utilizing established criteria impacts involving a typical range of vehicles on our roadways, from lightweight cars (approx. 820kg [1800 lb.]) to full size pickup trucks (approx. 2000 kg [4400 lb.]) as specified by the FHWA. A product can be certified for multiple Test Levels. The QuadGuard[®] system is certified to the Test Level(s) as shown below:

Test Level 2: 70 km/h [44 mph]

Test Level 3: 100 km/h [62 mph]

These FHWA directed tests are not intended to represent the performance of systems when impacted by every vehicle type or every impact condition existing on the roadway. This system is tested only to the test matrix criteria of NCHRP 350 as approved by FHWA.

Energy Absorption Systems does not represent nor warrant that the results of these NCHRP tests show that vehicle impacts with the products in other conditions would necessarily avoid injury to person(s) or property. Impacts that exceed criteria capabilities of the product may not result in acceptable impact performance as outlined in NCHRP Report 350, relative to structural adequacy, occupant risk, and vehicle trajectory. Energy Absorption Systems expressly disclaims any warranty or liability for injury or damage to persons or property resulting from any impact, collision, or harmful contact with products, other vehicles, or nearby hazards or objects by any vehicle, object or person, whether or not the products were assembled by or in the presence of Energy Absorption Systems representatives or by third parties.

The QuadGuard[®] system is intended to be assembled, delineated, and maintained in accordance with specific state and federal guidelines. It is important to select the most appropriate product configuration for a site. The customer should be careful to properly select, assemble, and maintain the product. Careful evaluation of the site geometry, vehicle population type, speed, traffic direction, and visibility are some of the elements that require evaluation in the proper selection of a safety appurtenance. For example, assemblies on curbs have not been tested, nor evaluated and should not be permitted. Before assembly of this system at any location, these issues need to be fully discussed with the appropriate highway authority planning and specifying the installation.

After an impact occurs, the product should be restored to its original condition as soon as possible. When a potentially reusable highway product is impacted, it is still necessary to restore the product to its original length and inspect all the components as necessary. What constitutes a potentially reusable highway product should only be determined by a trained engineer, experienced in highway products, directed by the DOT, or other appropriate local highway authority.

System Overview

The QuadGuard® system is a potentially reusable, redirective, non-gating crash cushion for hazards ranging in width from 610 mm to 3200 mm (24" to 126"). After those impacts observed within NCHRP 350 criteria, it has been observed that, potentially, the bulk of the system can be reused. The system consists of energy-absorbing Cartridges surrounded by a framework of Quad-Beam™ Panels. What constitutes a potentially reusable highway product should only be determined by a trained engineer, experienced in highway products, directed by the DOT, or other appropriate local highway authority.

The QuadGuard® system utilizes two types of Cartridges in a “staged” configuration to address both lighter cars and heavier, high center-of-gravity vehicles. Its modular design allows the system length to be tailored to the design speed of a site. See Table A on Page 12 to determine the appropriate length system for a given speed.

Impact Performance

The 6 bay QuadGuard® system has successfully passed the requirements stipulated in NCHRP Report 350, Test Level 3 tests with both the light car and pickup at speeds of up to 100 km/h [62 mph] at angles up to 20 degrees.

During head-on impacts, the QuadGuard® system telescopes rearward and crushes to absorb the energy of impact. When impacted from the side, within NCHRP 350 criteria, it has been observed to safely redirect the vehicle back toward its original travel path and away from the hazard.

How to Determine Left/Right

To determine left from right when ordering parts, stand in front of the system facing the hazard. Your left is the system’s left and your right is the system’s right.

Counting the Number of Bays

One Bay consists of one Cartridge, one Diaphragm, two Fender Panels, etc. The Nose section is not considered a Bay, though there is a Cartridge in the Nose of each system. Note that this means there will always be one more Cartridge in the system than the number of bays in the system. To determine number of Bays, count Fender Panels on one side (See Figure 1). Five Bay system shown (See Figure 1).

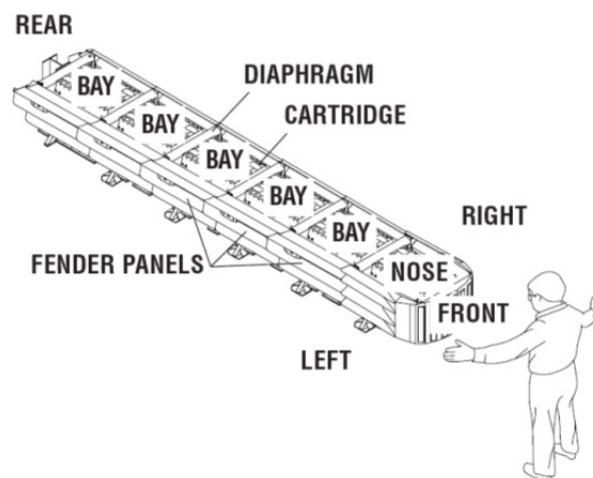

Figure 1
System Orientation

Measuring the Width

The QuadGuard® system is available in seven nominal widths:

- 610 mm [24"]
- 760 mm [30"]
- 915 mm [36"]
- 1220 mm [48"]
- 1755 mm [69"]
- 2285 mm [90"]
- 3200 mm [126"]

The nominal width of a system with Tension Strut Backup is the width between Side Panels behind the Backup (See Figure 2).

The nominal width of a system with Concrete Backup is the width of the Concrete Backup at location shown in Figure 3.

The outside width of the system is approximately 150 mm [6"] to 230 mm [9"] wider than the nominal width. The width of the system is not the same as the width of the Backup.

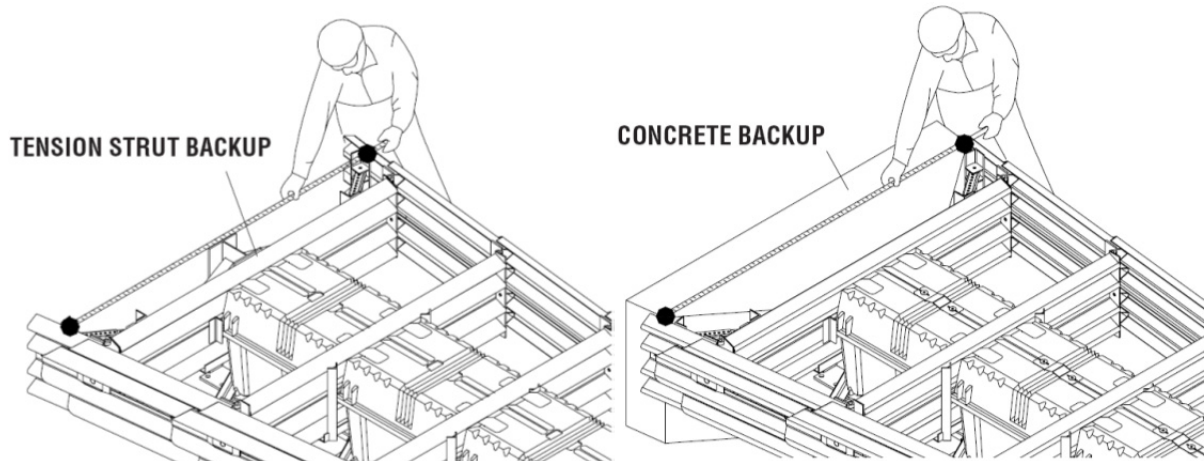

Figure 2
Width of system with Tension Strut Backup

Figure 3
Width of system with Concrete Backup

QuadGuard® System Criteria

Contact Energy Absorption Systems Customer Service Department if you would like input as to your specific application. Proper model selection is essential to the performance of the QuadGuard® System. You will need to answer the following questions:

1) Specification of System Width

The QuadGuard® system is available in seven nominal widths:

- 610 mm [24"]
- 760 mm [30"]
- 915 mm [36"]
- 1220 mm [48"]
- 1755 mm [69"]
- 2285 mm [90"]
- 3200 mm [126"]

As a general rule, selection of the narrowest width that adequately shields the hazard is recommended.

2) Specification of System Length

System length is specified by the number of Bays the system includes. The number of Bays required is a function of the intended speed of the roadway.

3) Specify Foundation

Note that the system must be anchored. MP-3® polyester anchor bolts will be supplied for all required anchorages in concrete. Refer to QuadGuard® Assembly Manual or MP-3® kits for detailed assembly instructions.

A. Is the system to be placed on existing concrete?

Existing concrete – Concrete must be at least 150 mm [6"] thick, reinforced 28 MPa [4000psi] Portland cement concrete (P.C.C.), or 200 mm [8"] thick non-reinforced 28 MPa [4000 psi] P.C. Concrete Roadway, measuring at least 3.66 m [12'-0"] wide by 15.24 m [50'-0"] long. The concrete should be in good condition and be free of major cracks.

New concrete – If existing concrete does not meet these criteria, then a new concrete pad must be placed to properly secure the system. See concrete pad details supplied with the system on Page 17 and Concrete Pad Reference drawings.

B. Is there a cross-slope at the construction site?

Cross-slope exists – If there is a cross-slope of more than 8% (5 degrees), or if the cross-slope varies (twists) more than 2% (1 degree) over the length of the system, a concrete leveling pad may be required (See Figure 4).

No Cross-slope – No additional action is required.

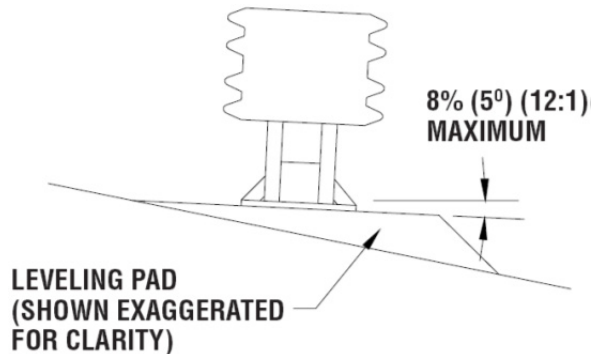

Figure 4
Cross-Slope

4) Specify Backup Structure

The two Backup designs available are the Tension Strut Backup and the Concrete Backup. Both types are appropriate for use on grade or deck.

5) Special Site Conditions

Contact Energy Absorption Systems Customer Service Department if you would like input with your application. You will need to answer the following questions:

1. **Are curbs, islands, or elevated objects (delineators or signs) present at the site? What height and width are they?** All curbs and elevated objects over 100 mm [4"] high should be removed. If possible, curbs taller than 100 mm [4"] high should be removed approximately 15 m [50'] in front of the QuadGuard® systems and as far back as the system's Backup. Any curbs that must remain should be 100 mm [4"] maximum and be mountable.
2. If the construction site is a gore area (place where two roads diverge), **what is the angle of divergence?**
3. **What is the general geometry of the site**, including the roadway for at least 150 m [500'] in front, so traffic patterns can be visualized?
4. **Is there an existing barrier?** Where there is an existing guardrail or median barrier at the site, the Backup of the QuadGuard® system should tie into it when possible.
5. **Will there be traffic approaching from the rear of the system?** Is the system in a two-way traffic situation, with traffic going in opposite directions on either side of the system? Or, is the system on the side of the road in a location where crossover traffic is a concern? If so, a Transition from the back of the system to the hazard is necessary to prevent vehicle interaction (See Page 22).
6. **Are there any other unique features at the site that may affect positioning or performance of the QuadGuard® system?**

6) Other Factors that May Affect Your Deployment:

1. The existence of drain inlets.
2. Junction boxes or other appurtenances located near the hazard.
3. Insufficient space for the length preferred.
4. The location and movement of expansion joints.

If these or any other special site conditions exist, please contact Energy Absorption Systems Customer Service Department before proceeding with your design (See Page 3).

Impact conditions which differ from those described in the NCHRP 350 test matrix for non-gating redirecting crash cushions, may result in different crash results than those encountered in testing.

Furthermore, impacts in excess of TL-3 impact severity, or the existence (at the site of assembly) of curbs or cross-slopes in excess of 8%, may yield performance which does not meet NCHRP 350 evaluation criteria relative to structural adequacy, occupant risk, and vehicle trajectory factors.

These following charts represent the modified versions of the QuadGuard[®] system length relative to impact speed, which is based on the capacity of the system using a 2000 kg [4400 lb] pickup truck.

Table A

QuadGuard Design Table (Avg G deceleration values)													
No. Bays	Effective Length	Design km/h Velocity (mph)	40 (25)	50 (31)	60 (37)	70 (44)	80 (50)	90 (56)	100 (62)	105 (65)	110 (68)	115 (71)	120 (75)
12*	11.79 m (38'-8")	120 (75)	---	---	---	---	---	---	---	---	---	5.2	5.6
11*	10.87 m (35'-8")	120 (75)	---	---	---	---	---	---	---	---	5.2	5.6	6.1
10*	9.96 m (32'-8")	120 (75)	---	---	---	---	---	---	---	---	5.6	6.1	6.7
9	9.04 m (29'-8")	115 (71)	---	---	---	---	---	---	---	5.6	6.2	6.8	7.4
8*	8.13 m (26'-8")	110 (68)	---	---	---	---	---	---	5.7	6.3	6.9	7.5	8.2
7*	7.21 m (23'-8")	105 (65)	---	---	---	---	---	5.2	6.4	7.1	7.8	8.5	9.2
6	6.30 m (20'-8")	100 (62)	---	---	---	---	4.7	5.9	7.3 (TL-3)	8.1	8.9	9.7	---
5*	5.38 m (17'-8")	90 (56)	---	---	---	4.2	5.5	7.0	8.6	9.5	10.4	---	---
4*	4.47 m (14'-8")	80 (50)	---	---	3.7	5.1	6.6	8.4	10.4	---	---	---	---
3	3.56 m (11'-8")	70 (44)	---	3.2	4.7	6.4 (TL-2)	8.3	10.5	---	---	---	---	---
2*	2.64 m (8'-8")	60 (37)	2.8	4.4 (TL-1)	6.3	8.6	11.2	---	---	---	---	---	---
1*	1.73 m (5'-8")	40 (25)	4.3	6.7	9.6	---	---	---	---	---	---	---	---

*System capacity estimated through calculation.

Avg G deceleration values are based upon average values calculated for vehicles 820 to 2000 kg (1800 to 4400 lbs.) that stop in a distance equal to 85% of the systems length.



Warning: Shaded area denotes excessive decelerations based upon occupant risk recommendations outlined in NCHRP 350 for 2000 kg (4400 lb.) vehicles. Energy Absorption Systems does not recommend choosing systems from this area of the chart.

Table B
QuadGuard® Standard System Model Numbers

Number of Bays	Nominal Width				
	610 mm [24"]	760 mm [30"]	915 mm [36"]	1755 mm [69"]	2285 mm [90"]
1	QS2401G or Y	QS3001G or Y	QS3601G or Y	N/A	N/A
2	QS2402G or Y	QS3002G or Y	QS3602G or Y	N/A	N/A
3	QS2403G or Y	QS3003G or Y	QS3603G or Y	QS6903G or Y	QS9003G or Y
4	QS2404G or Y	QS3004G or Y	QS3604G or Y	QS6904G or Y	QS9004G or Y
5	QS2405G or Y	QS3005G or Y	QS3605G or Y	QS6905G or Y	QS9005G or Y
6	QS2406G or Y	QS3006G or Y	QS3606G or Y	QS6906G or Y	QS9006G or Y
7	QS2407G or Y	QS3007G or Y	QS3607G or Y	QS6907G or Y	QS9007G or Y
8	QS2408G or Y	QS3008G or Y	QS3608G or Y	QS6908G or Y	QS9008G or Y
9	QS2409G or Y	QS3009G or Y	QS3609G or Y	QS6909G or Y	QS9009G or Y
10	QS2410G or Y	QS3010G or Y	QS3610G or Y	QS6910G or Y	QS9010G or Y
11	QS2411G or Y	QS3011G or Y	QS3611G or Y	QS6911G or Y	QS9011G or Y
12	QS2412G or Y	QS3012G or Y	QS3612G or Y	QS6912G or Y	QS9012G or Y

Model Number Description

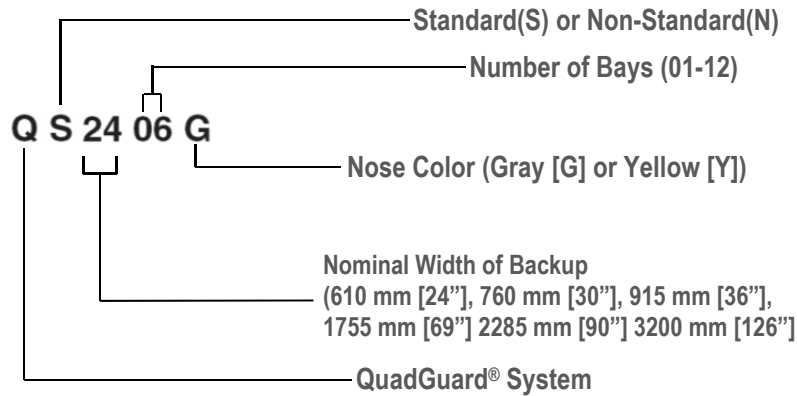

**QUADGUARD SYSTEM
FOR NARROW HAZARDS**

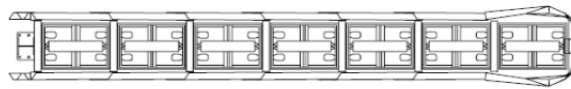

610 mm [24"] MODEL NO. QS2406

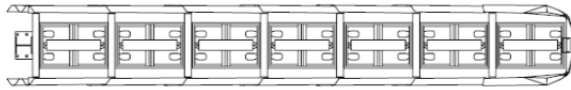

760 mm [30"] MODEL NO. QS3006

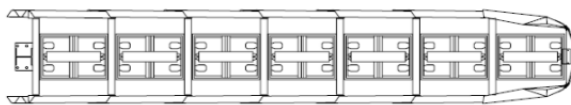

915 mm [36"] MODEL NO. QS3606

**QUADGUARD SYSTEM
FOR WIDE HAZARDS**

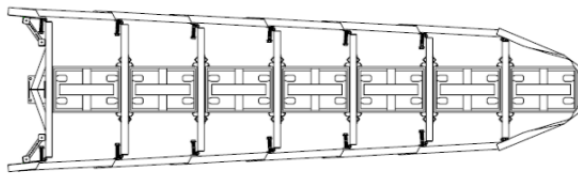

1755 mm [69"] MODEL NO. QS6906

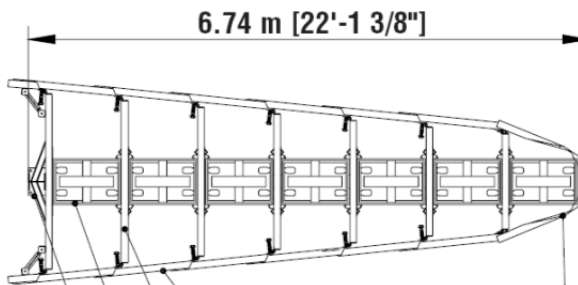

2285 mm [90"] MODEL NO. QS9006

- Key**
- ① Cartridge
 - ② Diaphragm
 - ③ Quad Beam Fender Panel
 - ④ Nose Cover
 - ⑤ Monorail
 - ⑥ Backup

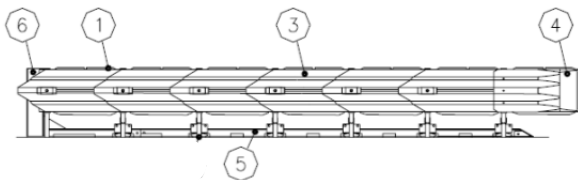

*Plan & Elevation (Six bay system with
Tension Strut backup Shown)*

**Figure 4
Plan and Elevation (Six bay System with
Tension Strut backup Shown)**

QuadGuard® CZ Design Criteria

This portable compact crash cushion is for construction zones. The QuadGuard® CZ system is available in the same narrow sizes as permanent systems. Wide systems are not available.

The QuadGuard® CZ system must be properly anchored. See Page 17 for the recommended anchorage for various foundations.

Table C
QuadGuard® CZ System Plate Model Numbers

Number of Bays	Nominal Width		
	610 mm [24"]	760 mm [30"]	915 mm [36"]
3	QZ2403PG or Y	QZ3003PG or Y	QZ3603PG or Y
4	QZ2404PG or Y	QZ3004PG or Y	QZ3604PG or Y
5	QZ2405PG or Y	QZ3005PG or Y	QZ3605PG or Y
6	QZ2406PG or Y	QZ3006PG or Y	QZ3606PG or Y
7	QZ2407PG or Y	QZ3007PG or Y	QZ3607PG or Y
8	QZ2408PG or Y	QZ3008PG or Y	QZ3608PG or Y
9	QZ2409PG or Y	QZ3009PG or Y	QZ3609PG or Y

Model Number Description

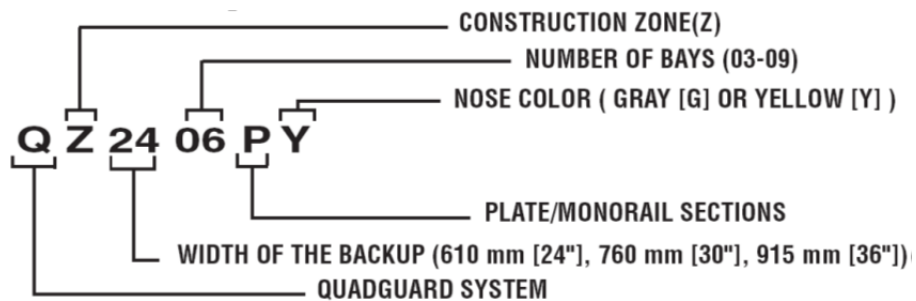

Table D

QuadGuard® CZ System Table (Avg G deceleration values)													
No. Bays	Effective Length	Design Velocity (km/h (mph))	40 (25)	50 (31)	60 (37)	70 (44)	80 (50)	90 (56)	100 (62)	105 (65)	110 (68)	115 (71)	120 (75)
9	9.04 m (29'-8")	115 (71)	---	---	---	---	---	---	---	5.6	6.2	6.8	7.4
8*	8.13 m (26'-8")	110 (68)	---	---	---	---	---	---	5.7	6.3	6.9	7.5	8.2
7*	7.21 m (23'-8")	105 (65)	---	---	---	---	---	5.2	6.4	7.1	7.8	8.5	9.2
6	6.30 m (20'-8")	100 (62)	---	---	---	---	4.7	5.9	7.3 (TL-3)	8.1	8.9	9.7	---
5*	5.38 m (17'-8")	90 (56)	---	---	---	4.2	5.5	7.0	8.6	9.5	10.4	---	---
4*	4.47 m (14'-8")	80 (50)	---	---	3.7	5.1	6.6	8.4	10.4	---	---	---	---
3	3.56 m (11'-8")	70 (44)	---	3.2	4.7	6.4 (TL-2)	8.3	10.5	---	---	---	---	---

*System capacity estimated through calculation.

Average G deceleration values are based upon average values calculated for vehicles 820 to 2000 kg (1800 to 4400 lbs.) that stop in a distance equal to 85% of the systems length.



Warning: Shaded area denotes excessive decelerations based upon occupant risk recommendations outlined in NCHRP 350 for 2000 kg (4400 lb.) vehicles. Energy Absorption Systems does not recommend choosing systems from this area of the chart.

QuadGuard[®] and QuadGuard[®] CZ Foundation/Anchoring

Concrete Installations

For concrete installations, the QuadGuard[®] system should be installed only on an existing or freshly placed and cured concrete base (28 MPa [4000 psi] minimum). Orientation of the concrete base and the attenuator must comply with the project plans or as otherwise determined by the resident project engineer or appropriate highway authority.

Recommended dimension and reinforcement specifications for new concrete pads can be found on the standard drawings.

Asphalt Installations

For asphalt installations in construction zones, QuadGuard[®] system may be installed on asphalt. Only systems with a Tension-Strut Backup may be installed on asphalt. Provide a minimum of 76 mm [3"] layer of asphalt over a minimum of 76 mm [3"] layer of Portland Cement concrete, 152 mm [6"] layer of asphalt over 152 mm [6"] layer of subbase, or 203 mm [8"] layer of asphalt with no subbase or 460 mm [18"] threaded rods, installed with the two-part MP-3[®] grout must be used for these foundations.



Important: Systems mounted on asphalt must be replaced and mounted on fresh, undisturbed asphalt if more than 10% of anchors are found to be loose, broken, or show signs of pull out. If 10% or fewer anchors are damaged, replace the damaged anchors in the existing asphalt. Anchor bolts used on systems mounted on asphalt must be inspected every 6 months. See Post Impact Instructions and Maintenance and Repair instructions in the QuadGuard[®] Assembly Manual for details.

The QuadGuard[®] system may be installed on any of the following foundations using the specified anchorage:

Foundation A: Concrete Pad or Roadway

Foundation: 150 mm [6"] minimum depth Portland Cement Concrete (P.C.C.)

Anchorage: MP-3[®] with 180 mm [7"] studs 140 mm [5.5"] embedment

Foundation B: Asphalt over P.C.C.

Foundation: 76 mm [3"] minimum asphalt concrete (A.C.) over 76 mm [3"] minimum P.C.C.

Anchorage: Length of anchor required is 460 mm [18"] 420 mm [16.5"] embedment

Foundation C: Asphalt over Subbase

Foundation: 150 mm [6"] minimum A.C. over 150 mm [6"] minimum Compacted Subbase (C.S.)

Anchorage: MP-3[®] with 460 mm [18"] studs 420 mm [16.5"] embedment

Foundation D: Asphalt Only

Foundation: 200 mm [8"] minimum A.C.

Anchorage: MP-3[®] with 460 mm [18"] studs - 420 mm [16.5"] embedment

Foundation Specifications

for Foundations A, B, C and D mentioned above:

A. C. (Asphalt Concrete)

AR-4000 A. C. (per ASTM D3381 '83) .75" Maximum, Medium (Type A or B) aggregate

Sieve Size	Operating Range (%) Passing
1"	100
3/4"	95-100
3/8"	65-80
No. 4	49-54
No. 8 3	6-40
No. 30 1	8-21
No. 200	3-8



Caution: Walk-up inspections are recommended at least once every six months for installations on asphalt.

P.C.C. (Portland Cement Concrete)

Stone aggregate concrete mix

4000 psi minimum compressive strength

(Sampling per ASTM C31-84 or ASTM C42-84a, testing per ASTM C39-84)

C.S. (Compacted Subbase)

150 mm [6"] minimum depth 95% compaction

Class 2 aggregate

Sieve Size	Moving Average % Passing
3"	100
2 1/2"	90-100
No. 4	40-90
No. 200	0-25

Site Preparation/Foundation

Establish Required System Footing

Note that the system must be anchored. MP-3[®] polyester anchor bolts will be supplied for all required anchorages in concrete. Refer to QuadGuard[®] Assembly Manual or MP-3[®] kits for detailed assembly instructions.

A. Is the system to be placed on existing concrete?

Existing concrete – Concrete must be at least 150 mm [6"] thick, reinforced 28 MPa [4000psi] Portland Cement Concrete (P.C.C.), or 200 mm [8"] thick non-reinforced 28 MPa [4000 psi] P.C. Concrete Roadway, measuring at least 3.66 m [12'-0"] wide by 15.24 m [50'-0"] long. The concrete should be in good condition and be free of major cracks.

New concrete – If existing concrete does not meet these criteria, then a new concrete pad must be placed to properly secure the system. See concrete pad details supplied with the system.

B. Is there a cross-slope at the construction site?

If Cross-slope– If there is a cross-slope of more than 8% (5 degrees), or if the cross-slope varies (twists) more than 2% (1 degree) over the length of the system, a concrete leveling pad may be required (See Figure 10).

No Cross-slope – No additional action is required.

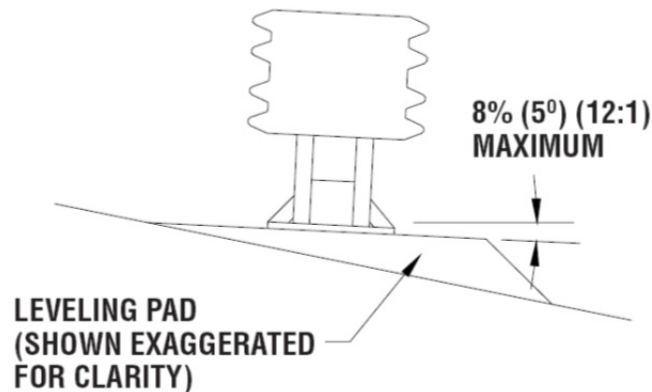

Figure 5
Cross-Slope

The QuadGuard[®] system is potentially reusable. Depending on the impact, components may get damaged and need replacement. The system must be inspected and restored after each impact by the appropriate highway authority.

Recommended Tools

Documentation

- Manufacturer's Assembly Manual
- Manufacturer's Drawing Package

Cutting equipment

- Rebar cutting bit
- Concrete drill bits – 22 mm [7/8"] (*Two Fluted)
- Grinder, Hacksaw, or Torch (optional)
- Rotary hammer drill
- Drill motor
- Drill bits 1/16" through 7/8"

Note: Energy Absorption Systems recommends using two fluted drills to achieve optimum tensile strength when applying the MP-3[®] anchoring system. That decision must be confirmed with the highway authority authorizing the assembly and confirmed that it is assembled to their specification.

Hammers

- Sledgehammer
- Standard hammer

Wrenches

- Heavy duty impact wrench
- Standard adjustable wrench
- 1/2" drive sockets: 9/16", 11/16", 3/4", 15/16", 1 1/8", 1 1/4"
- 1/2" drive Deep sockets: 5/16", 1 1/4"
- Ratchet and attachments for the above sockets
- 1/2" drive Breaker bar - 24" long
- 1/2" drive Torque wrench: 200 ft.-lbs.
- Crescent Wrench: 300 mm [12"]
- Allen Wrench: 3/8
- Impact Wrench: 1/2"

Personal Protective equipment

- Safety glasses
- Gloves
- Safety toe shoes
- Apron

Miscellaneous

- Traffic control equipment
- Lifting and moving equipment (A lifting device is preferred although a forklift can be used.) Minimum 5,000 lb. capacity required.
- Air Compressor (100 psi minimum) and Generator (5 kW)
- Long pry bar
- Drift pin 300 mm [12"]
- Center punch
- Tape measure 7.5 m [25']
- Chalk line
- Concrete marking pencil
- Nylon bottle brush for cleaning 7/8" drilled holes
- Rags, water, and solvent for touch-up

Note: The above list of tools is a general recommendation. Depending on specific site conditions and the complexity of the assembly specified by the appropriate highway authority, additional or fewer tools may be required. Decisions as to what tools are required to perform the job are entirely within the discretion of the specifying highway authority and the authority's selected contractor performing the assembly of the system at the authority's specified site.

Transitioning

Quad-Beam End Shoe

Transition Panel

The Quad-Beam End Shoe Panel transitions the QuadGuard® system to vertical faced concrete structures whether it is a concrete backup or concrete barrier wall (See Page 22). An Extended End Shoe is also available. In cases where the corners of the hazard are not chamfered it may be necessary to add wheel deflectors to the structure in order to prevent wheel interaction.

Quad-Beam to Guardrail Transition Panel (W-Beam and Thrie-Beam)

The Quad-Beam to W-Beam and Quad-Beam to Thrie-Beam Transition Panels transition the QuadGuard® system to new and existing runs of standard guardrail (See Page 22).

Quad-Beam to Safety Barrier Transition Panel

There are several options available when transitioning the QuadGuard® system to safety shape barrier depending on the shape and position of the barrier.

When transitioning to barriers with a “New Jersey” style profile, the 4” offset transition panel is most commonly used (See Page 22). For transitioning to barriers that are in line with the side of the system, use transition assembly 354018L or R. For transitioning a wide system to barrier that runs parallel to the centerline of the system, transition assembly 354042L or R is used. A 9” offset transition panel is also available for transitioning to barriers that are in line with the side of the system.

When transitioning to Single Slope style barriers and parapets, 6” and 8” offset transition panels are available. For transitioning a wide system to Single Slope style barrier that runs parallel to the centerline of the system, a 6” offset Panel is available.

How do you determine the transition panel offset?

Transition Panel Offset is determined by measuring the distance between the face of the barrier and the top edge of the backup diaphragm at 32” above ground level (**See Figure 7**). Remember, when installing the QuadGuard® system that the correct transition panel offset must be achieved in order for the offset bracket to nest between the barrier and transition panel ensuring proper performance of the transition.

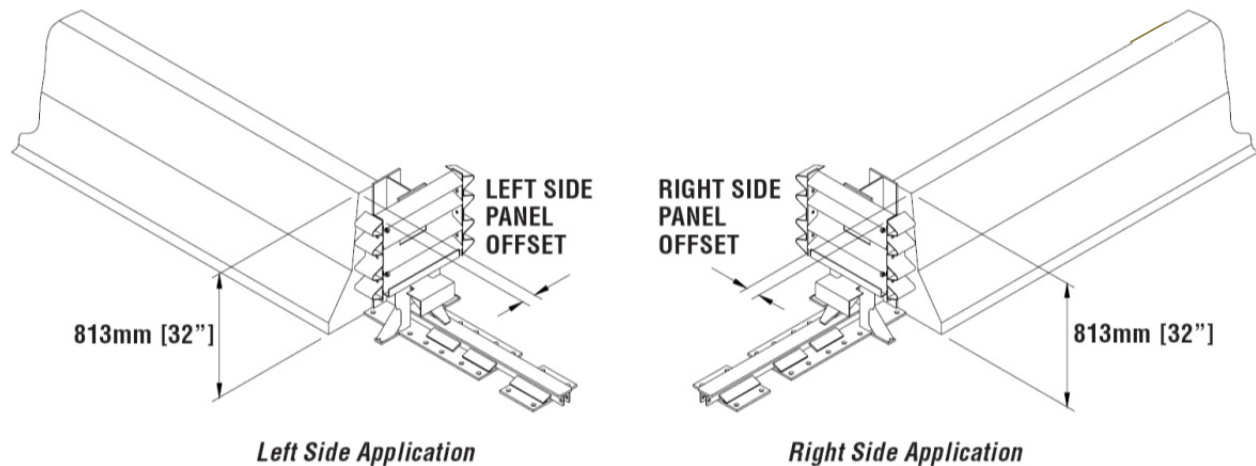

Figure 6
Transition Panel Offset

Transition Panel Types

If a system is placed in a location where traffic will be approaching from the rear, a transition panel is necessary. Figures 6, 7, 8 and 9 show standard Panel types. There are variations for each panel type. The specific Panel applied will depend on system and site conditions. Therefore, it is important to send site specific data to the customer service department for a recommendation for exact Panel requirements of your application.

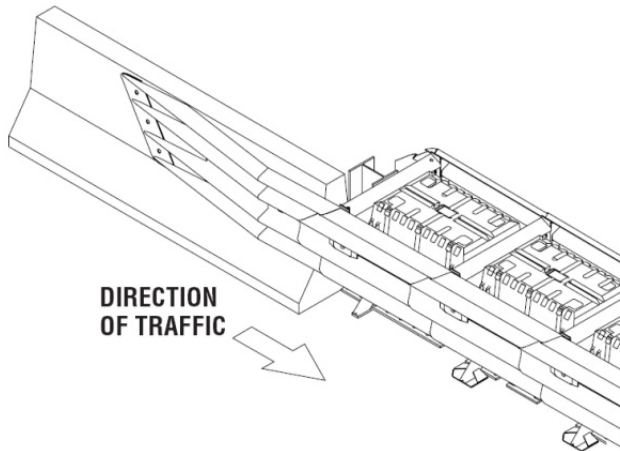

Figure 7
Quad-Beam to Safety Barrier (NJ shape)
Transition Panel

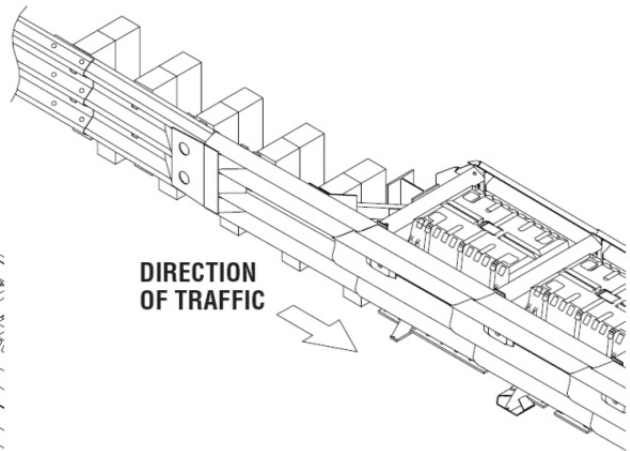

Figure 8
Quad-Beam to Thrie-Beam
Transition Panel

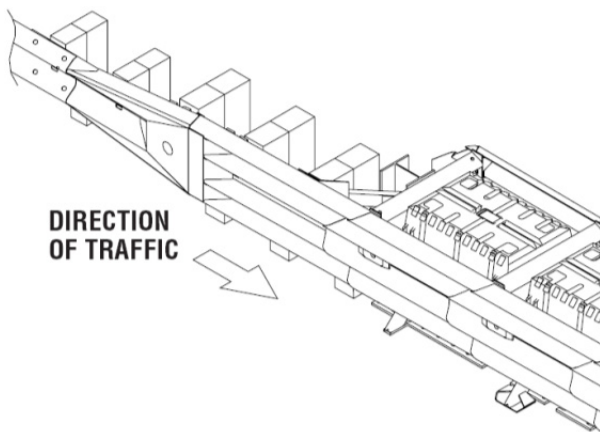

Figure 9
Quad-Beam to W-Beam Transition Panel

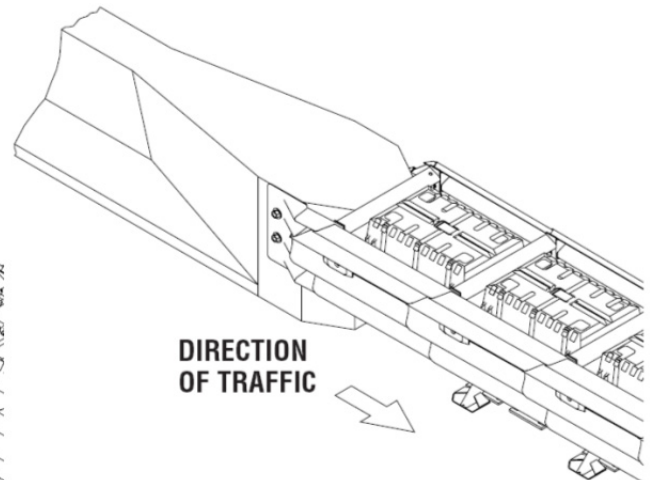

Figure 10
Quad-Beam End Shoe Transition Panel

Life Expectancy

Environment

It is anticipated that the Cartridges will survive in a highway environment for a period ranging from 10 to 15 years from the date of manufacture unless impact damage renders them otherwise. This is an estimate and should, in no way, be interpreted as a guarantee, or a warranty. All conditions and environments are different and the ultimate decision as to a whether or not the Cartridge is viable is within the sound discretion of the highway authority that owns and has specified the use of the system.

Impacts

Life expectancy is also dependent on the impacts. This includes:

1. Number of impacts
2. Severity of the impacts

Systems must be inspected after each impact. Any Cartridge that is crushed or otherwise damaged shall be replaced and the system pulled out to its original length.

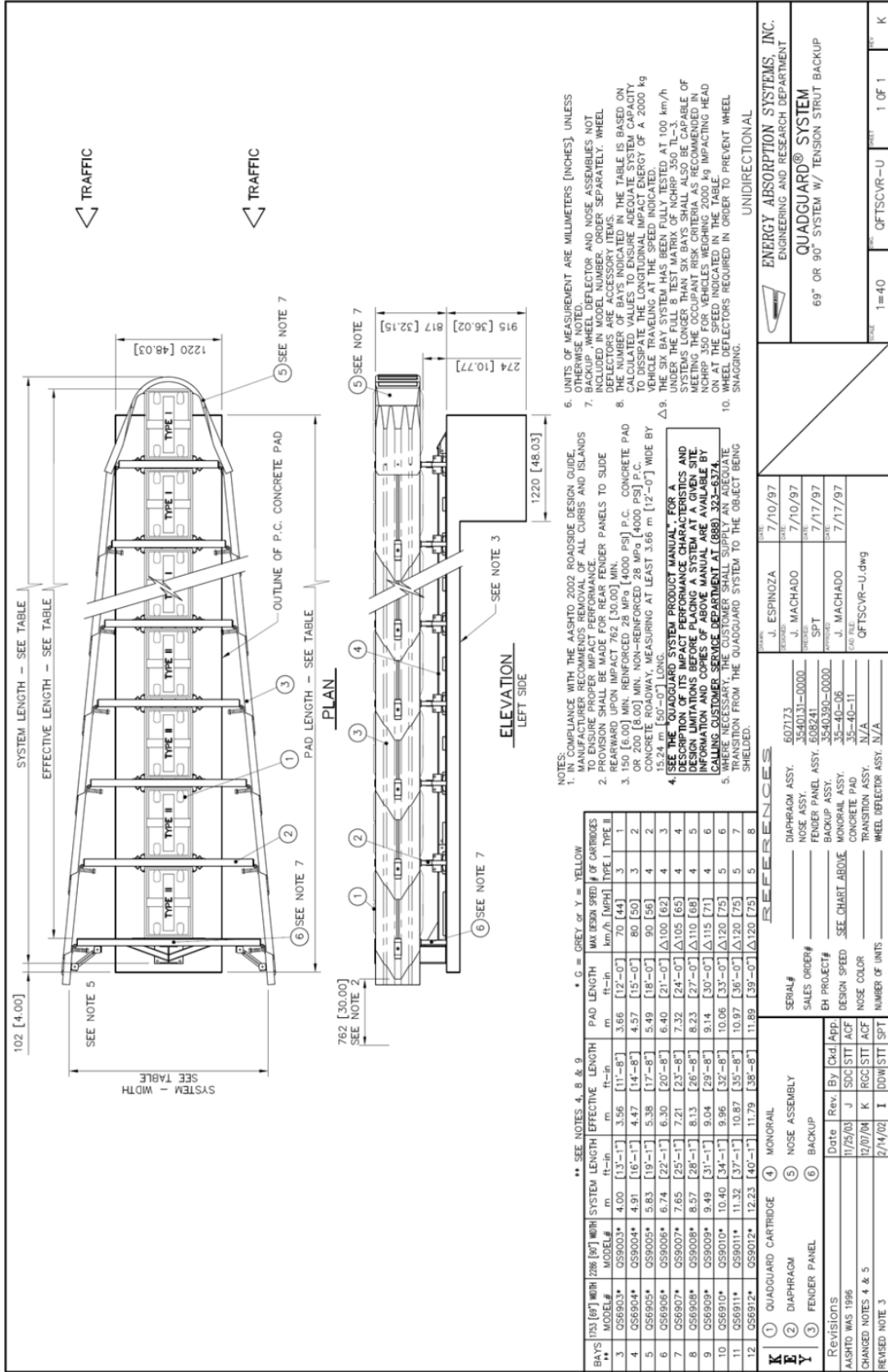

DWG QFTSCVR-U

QuadGuard® 69" or 90" System w/ Tension Strut Backup

- UNIDIRECTIONAL
- IN COMPLIANCE WITH THE AASHTO 2002 ROADSIDE DESIGN GUIDE, MANUFACTURER RECOMMENDS REMOVAL OF ALL CURBS AND ISLANDS REARWARD UPON IMPACT 762 [30.00] MIN.
 - PROVISION SHALL BE MADE FOR REAR FENDER PANELS TO SLIDE
 - 150 [6.00] MIN. NON-REINFORCED 28 MPa [4000 PSI] P.C. CONCRETE PAD OR 200 [8.00] MIN. NON-REINFORCED 28 MPa [4000 PSI] WIDE BY 15.24 m [50'-0"] LONG.
 - THE QUADGUARD SYSTEM PROTECTS HUMANITY FOR A LIMITED PERIOD OF TIME. PERFORMANCE CHARACTERISTICS AND DESIGN LIMITATIONS BEFORE PLACING A SYSTEM AT A GIVEN SITE INFORMATION AND COPIES OF ABOVE MANUAL ARE AVAILABLE BY CALLING CUSTOMER SERVICE DEPARTMENT AT (888) 322-5374.
 - WHERE NECESSARY, THE CUSTOMER SHALL SUPPLY AN ADEQUATE SHELTER.
 - UNITS OF MEASUREMENT ARE MILLIMETERS [INCHES], UNLESS BACKUP WHEEL DEFLECTOR AND NOSE ASSEMBLY. WHEEL DEFLECTORS ARE ACCESSORY ITEMS.
 - THE NUMBER OF BAYS INDICATED IN THE TABLE IS BASED ON THE LONGITUDINAL IMPACT ENERGY OF A 2000 kg VEHICLE TRAVELING AT THE SPEED INDICATED.
 - THE SIX BAY SYSTEM HAS BEEN FULLY TESTED AT 100 km/h UNDER THE FULL 8 TEST MATRIX OF NCHRP 350 TL-3. THE NUMBER OF BAYS INDICATED IN THE TABLE IS BASED ON THE OCCUPANT RISK CRITERIA AS RECOMMENDED IN NCHRP 350 FOR VEHICLES WEIGHING 2000 kg IMPACTING HEAD ON AT THE SPEED INDICATED IN THE TABLE.
 - WHEEL DEFLECTORS REQUIRED IN ORDER TO PREVENT WHEEL SHAGGING.

QUADGUARD SYSTEM		ENERGY ABSORPTION SYSTEMS, INC.	
69" OR 90" SYSTEM W/ TENSION STRUT BACKUP		ENGINEERING AND RESEARCH DEPARTMENT	
SCALE 1=40		DATE 7/10/97	
REV		DATE	
1	J. ESPINOZA	7/10/97	
2	J. MACHADO	7/10/97	
3	SPT	7/17/97	
4	J. MACHADO	7/17/97	
5	OFTSCVR-U.dwg		

REFERENCES	
DIAPHRAGM ASSY.	607173
NOSE ASSEMBLY	3540131-0000
FENDER PANEL ASSY.	608241
BACKUP ASSY.	3540390-0000
CONCRETE PAD	35-40-06
TRANSITION ASSY.	35-40-11
WHEEL DEFLECTOR ASSY.	N/A

REV	DATE	BY	CHKD	APP'D
1	11/25/03	J	SDG	SIT
2	12/07/04	K	RCG	SIT
3	2/14/02	I	DDM	SIT

REVISED NOTE	NUMBER OF UNITS
1	1

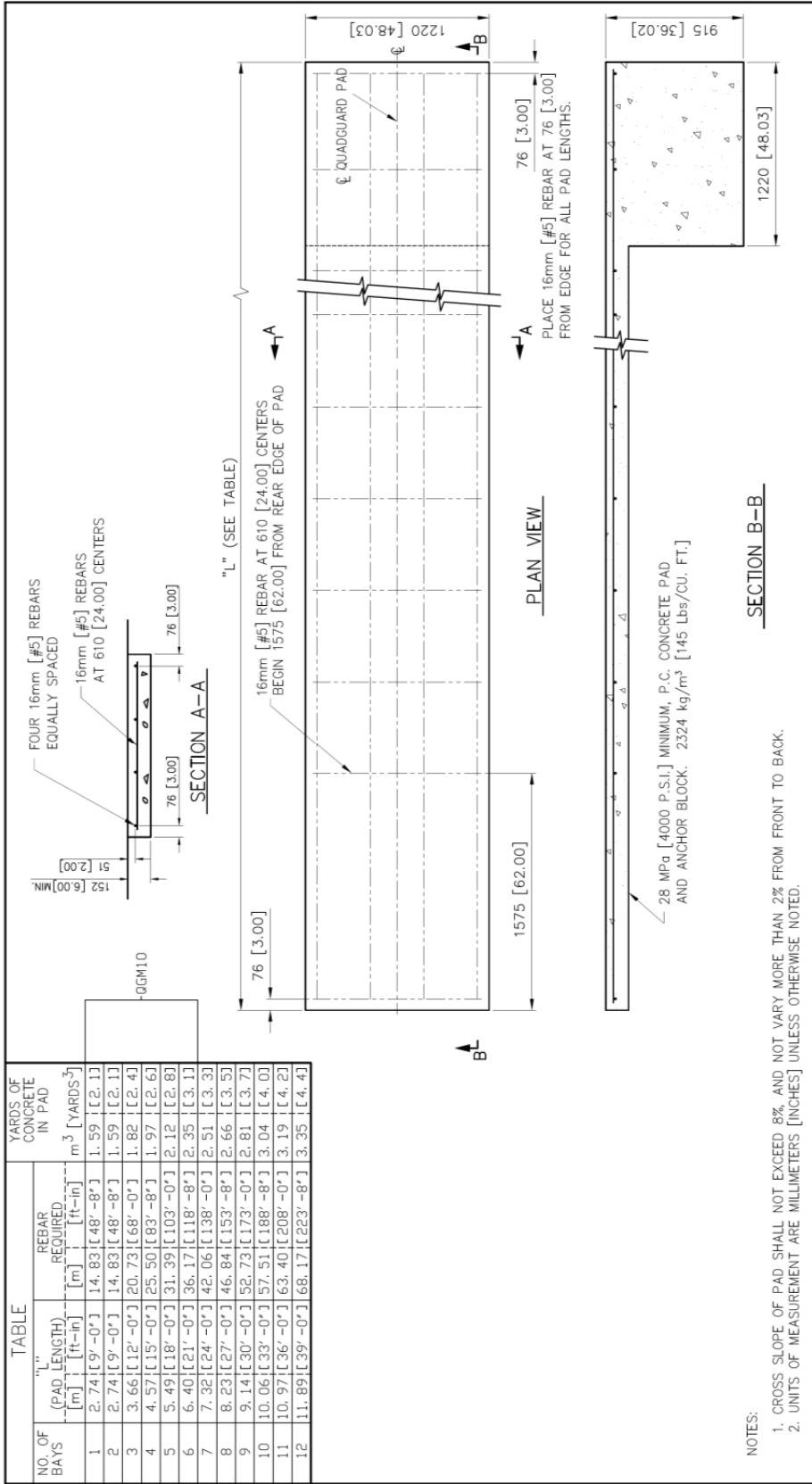

NO. OF BAYS	"L" (SEE TABLE)		YARDS OF CONCRETE IN PAD
	(PAD LENGTH) [m] [ft-in]	REBAR REQUIRED [m] [ft-in]	
1	2.74 [9'-0"]	14.83 [48'-8"]	1.59 [2.1]
2	2.74 [9'-0"]	14.83 [48'-8"]	1.59 [2.1]
3	3.66 [12'-0"]	20.73 [68'-0"]	1.82 [2.4]
4	4.57 [15'-0"]	25.50 [83'-8"]	1.97 [2.6]
5	5.49 [18'-0"]	31.39 [103'-0"]	2.12 [2.8]
6	6.40 [21'-0"]	36.17 [118'-8"]	2.35 [3.1]
7	7.32 [24'-0"]	42.06 [138'-0"]	2.51 [3.3]
8	8.23 [27'-0"]	46.84 [153'-8"]	2.66 [3.5]
9	9.14 [30'-0"]	52.73 [173'-0"]	2.81 [3.7]
10	10.06 [33'-0"]	57.51 [188'-8"]	3.04 [4.0]
11	10.97 [36'-0"]	63.40 [208'-0"]	3.19 [4.2]
12	11.89 [39'-0"]	68.17 [223'-8"]	3.35 [4.4]

NOTES:
 1. CROSS SLOPE OF PAD SHALL NOT EXCEED 8%, AND NOT VARY MORE THAN 2% FROM FRONT TO BACK.
 2. UNITS OF MEASUREMENT ARE MILLIMETERS [INCHES] UNLESS OTHERWISE NOTED.

ENERGY ABSORPTION SYSTEMS, INC.
 ENGINEERING AND RESEARCH DEPARTMENT

QUADGUARD® SYSTEM
 CONCRETE PAD FOR
 TENSION STRUT BACKUP

DATE: 5/15/96
 DESIGNED BY: D. Staus
 CHECKED BY: W. G. Krage
 DATE: 3/1/96
 DATE: 5/20/96
 DATE: 5/20/96

PROJECT: NTS
 SHEET: 35-40-11
 OF: 1 of 2

REFERENCES

Revisions	Date	Rev. By	Chd. App.
ADDED SHEET 2	12/03/03	E	RGC STT ACF
REVISED TO MATCH SHEET 2	09/28/00	F	RJV /
ECO 3145; ADDED QGM10 TO TABLE	08/9/11	G	DDJ/LME/ST

DWG 354011 Sheet 1 of 2

QuadGuard® Concrete Pad for Tension Strut Backup

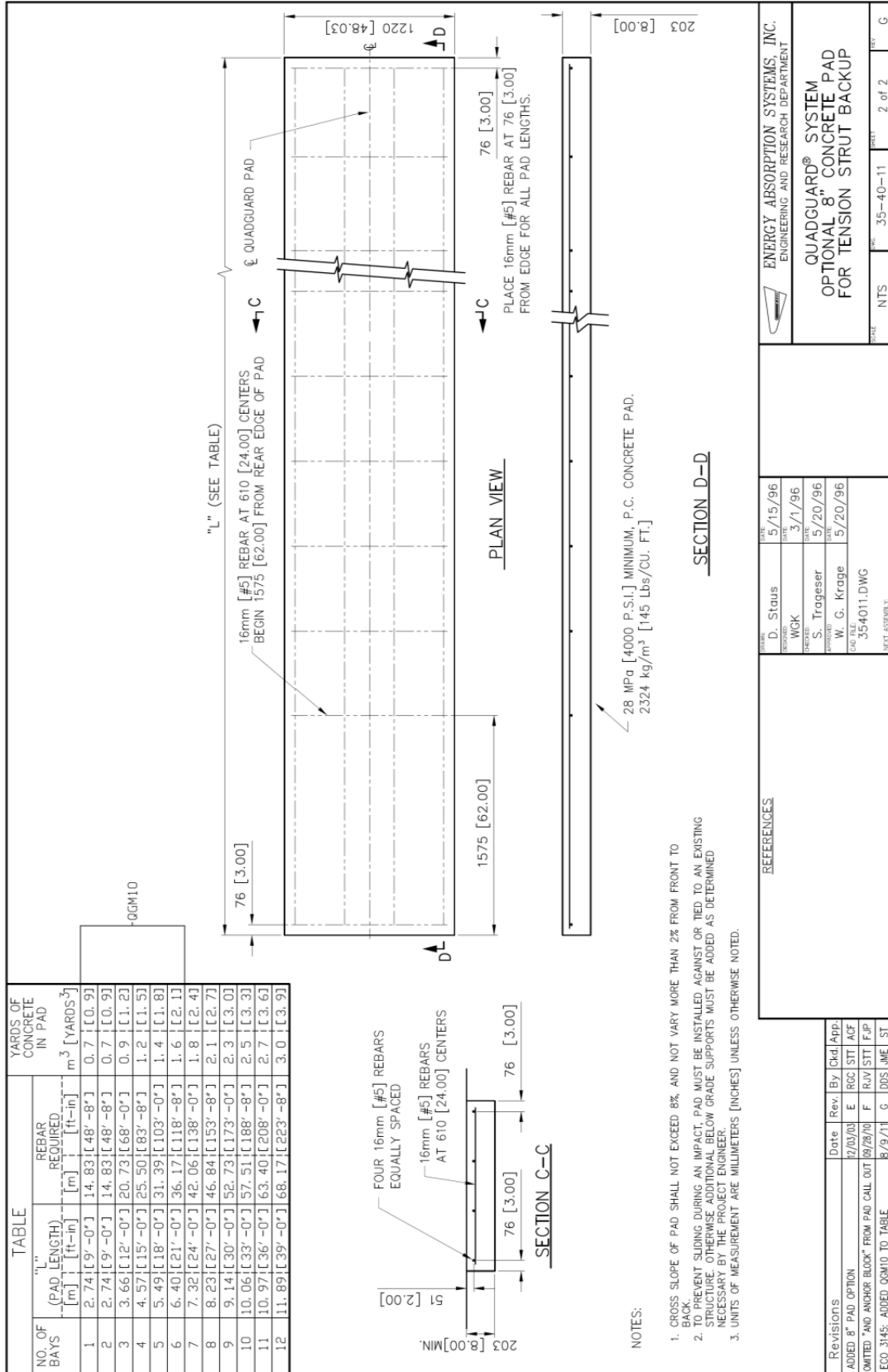

DWG 354011 Sheet 2 of 2

QuadGuard® Optional 8" Concrete Pad for Tension Strut Backup

PARTS LIST			
ITEM	STOCK NO.	DESCRIPTION	REQD.
1	SEE TABLE A	BACKUP.TS.OG.G	1.00
2	611898G	PANEL.SIDE.OG.G	2.00
9	603673B	ANCHOR.MP-3.PT-KIT.3/4X7.VT	3.00
10	003340G	NUT.HX.5/8.G.RAIL	4.00
11	003400G	BOLT.RAIL.5/8X2.G	4.00
12	605447B	BRACKET.CARTRIDGE.SUPPORT.TS.B/U	1.00
13	611266B	LOCKING.BAR.CARTRIDGE.SUPPORT	1.00

TABLE A			
ASSY. NO.	STOCK NO.	DESCRIPTION	WIDTH
604570B	604741B	BACKUP.TS.24.OG.G	610 [24.00]
604574B	604748B	BACKUP.TS.30.OG.G	760 [30.00]
604584B	604762B	BACKUP.TS.36.OG.G	915 [36.00]
604590B	604770B	BACKUP.TS.48.OG.G	1219 [48.00]

NOTES:
 1. WHEN TRANSITIONING QUADGUARD SYSTEM TO EXISTING BARRIER REFER TO THE TRANSITION ASSEMBLY DRAWINGS FOR PROPER USE OF SIDE PANEL PART NO. 611898G.

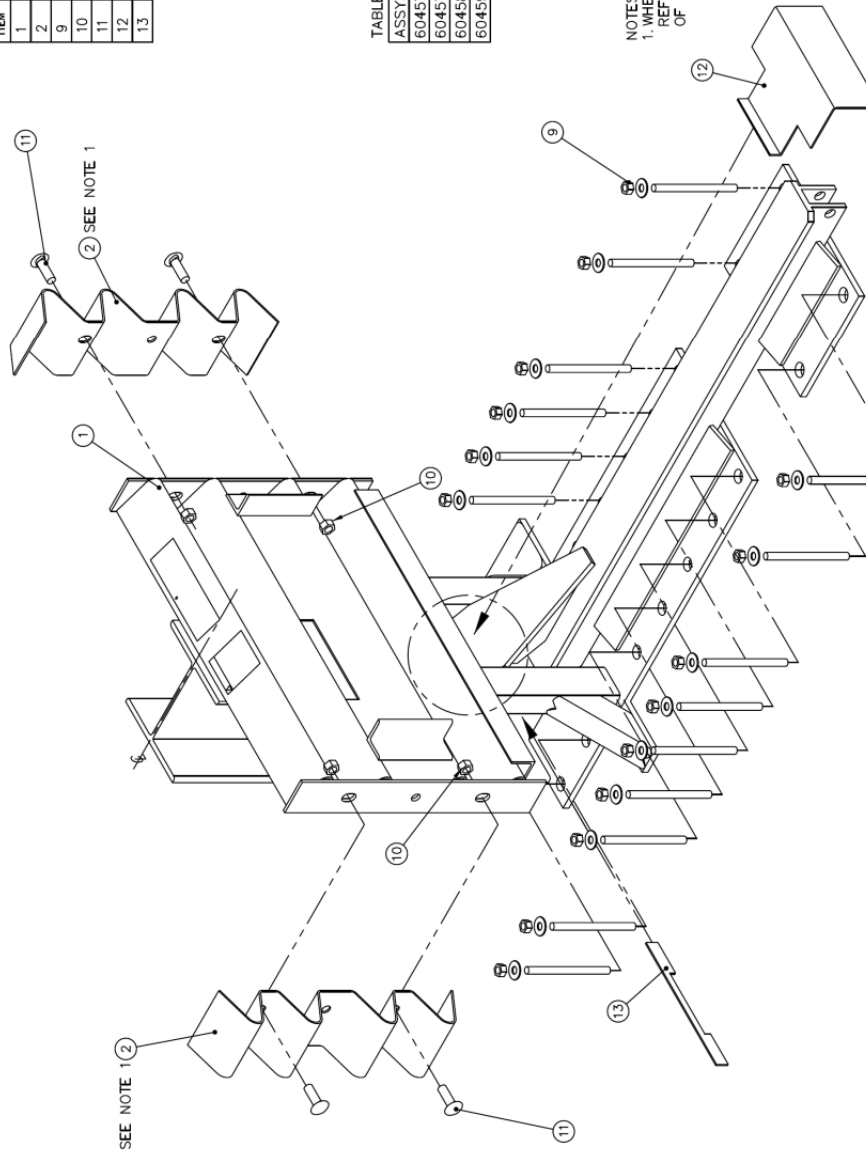

DATE	4-22-96
DESIGNED BY	S. LEWIS
CHECKED BY	JVM/MHO
DATE	3-1-96
DESIGNED BY	S. Trageser
APPROVED BY	J. Machado
DATE	5/16/96
CAD FILE	354003.dwg
NOT ASSEMBLY	

ASSEMBLY NO. SEE TABLE A
ENERGY ABSORPTION SYSTEMS, INC. ENGINEERING AND RESEARCH DEPARTMENT
QUADGUARD® SYSTEM
BACKUP ASSY, TS, QG
SCALE N.T.S. INC. 35-40-03 1 of 1

REVISONS	Date	Rev.	By	Chd.	App.
REMOVED 1 ANCHOR BOLT & ADDED NOTE	03/19/98	F	LWC	KM	SPT
ADDED 48" ASSY INFO INTO TABLE A	06/04/08	G	RJV	STT	RCB
PART NOS WERE 354003, 32, 33 & 30-0000	9/26/11	/	/	DDJ	/

REFERENCES

QuadGuard® Backup Assembly, TS

DWG 354003

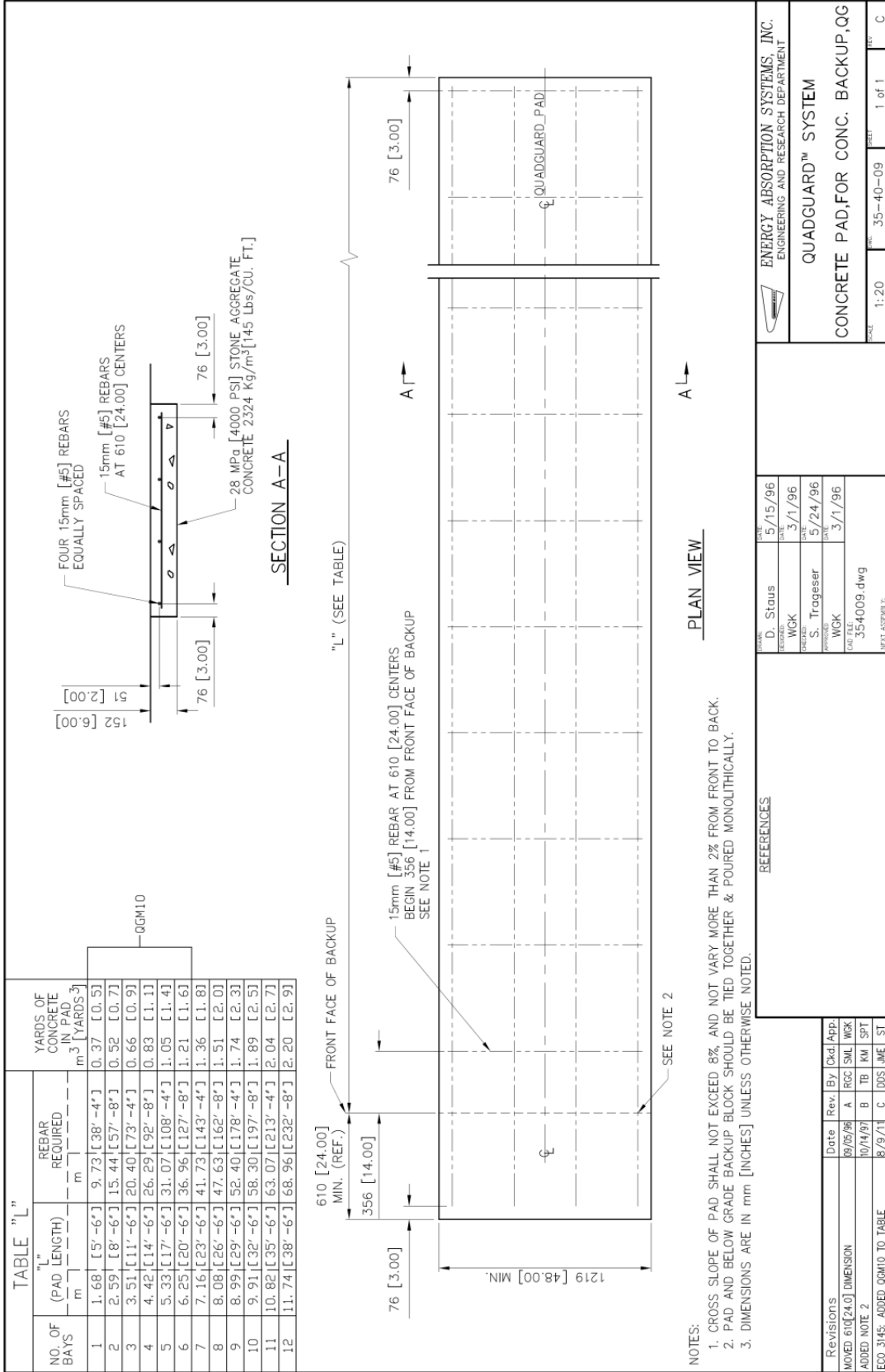

QuadGuard® Concrete Pad for Concrete Backup

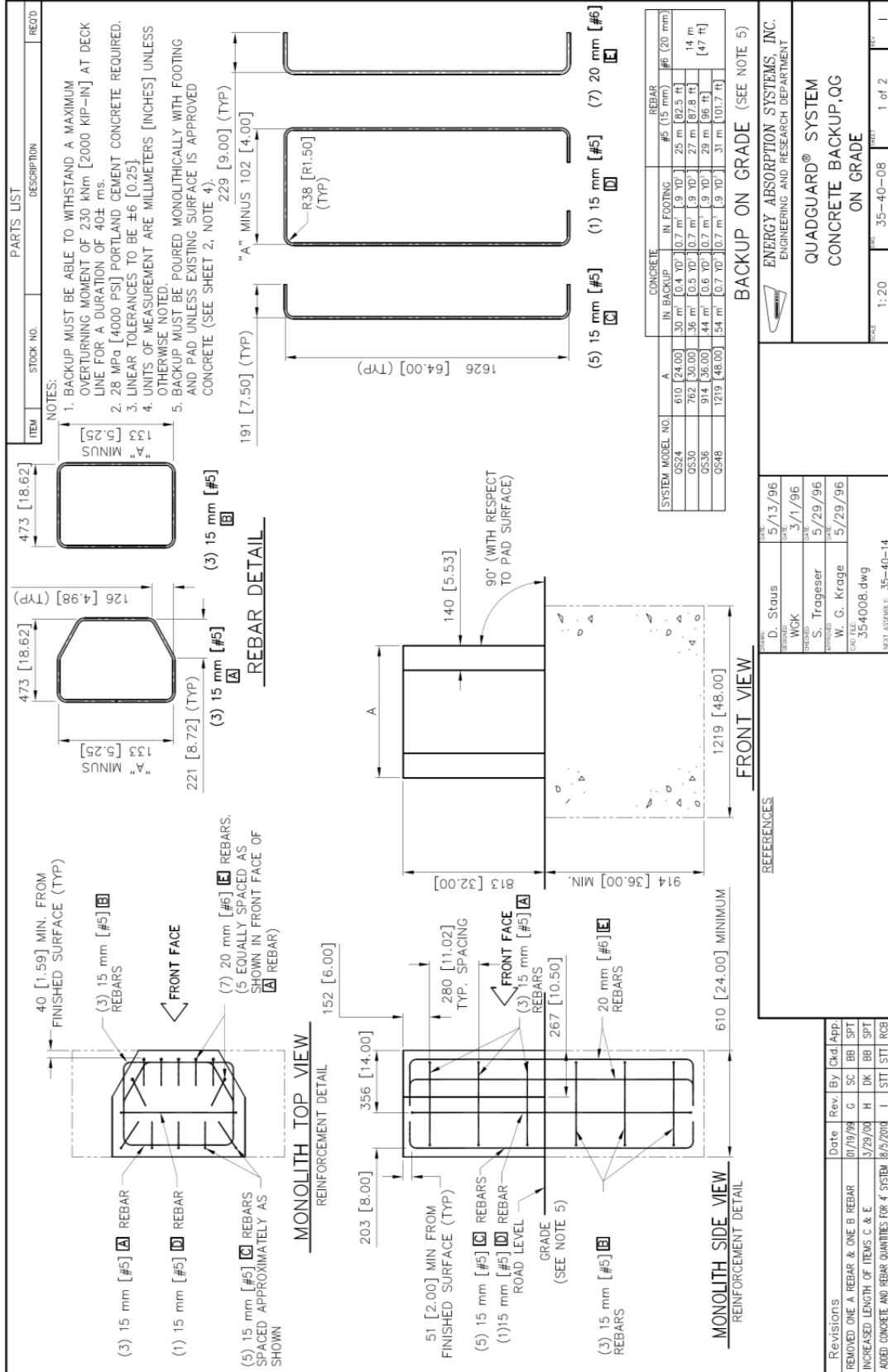

QuadGuard® Concrete Backup on Grade

DWG 354008 Sheet 1 of 2

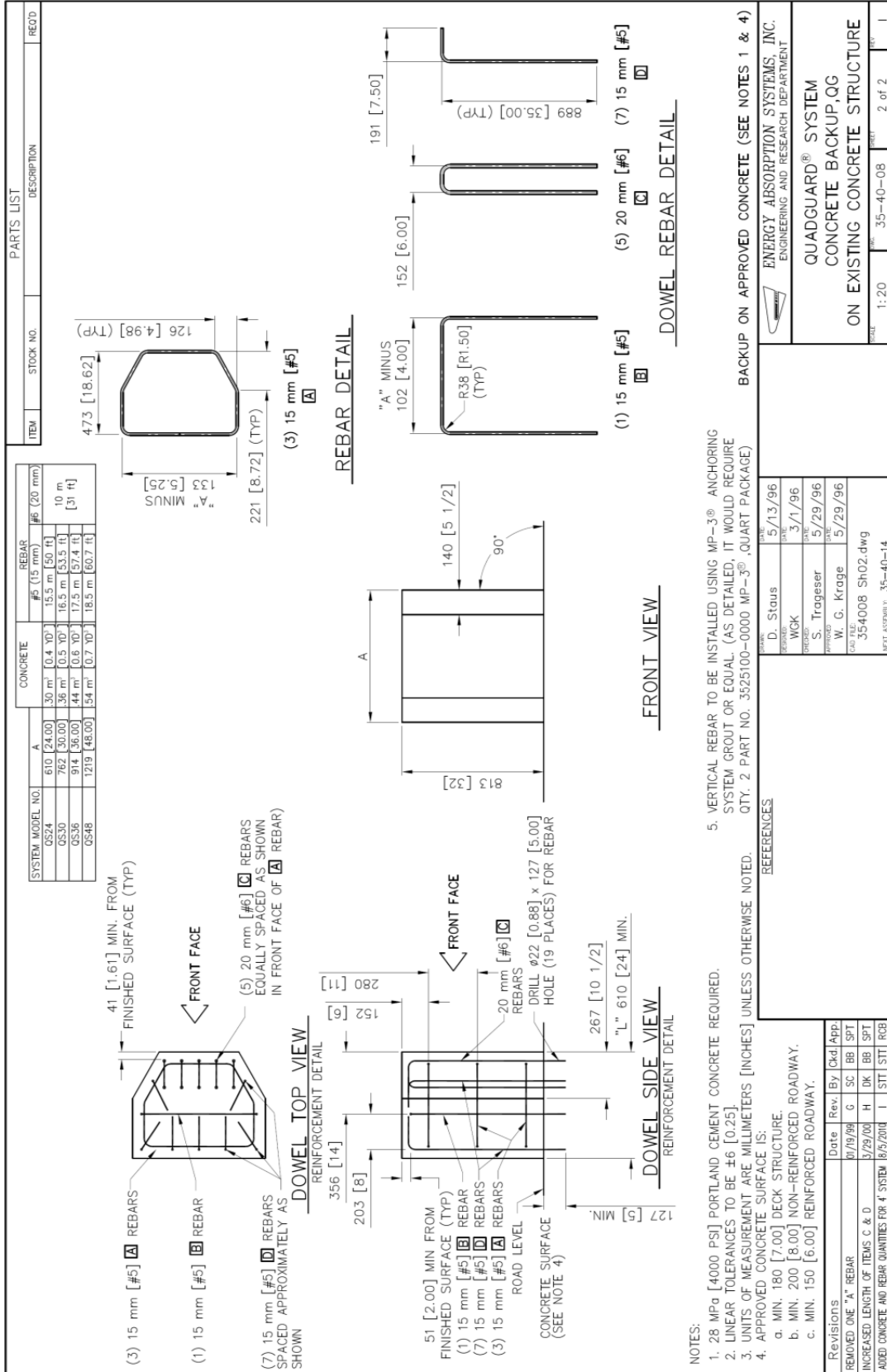

DWG 354008 Sheet 2 of 2

QuadGuard® Concrete Backup on Existing Concrete Structure

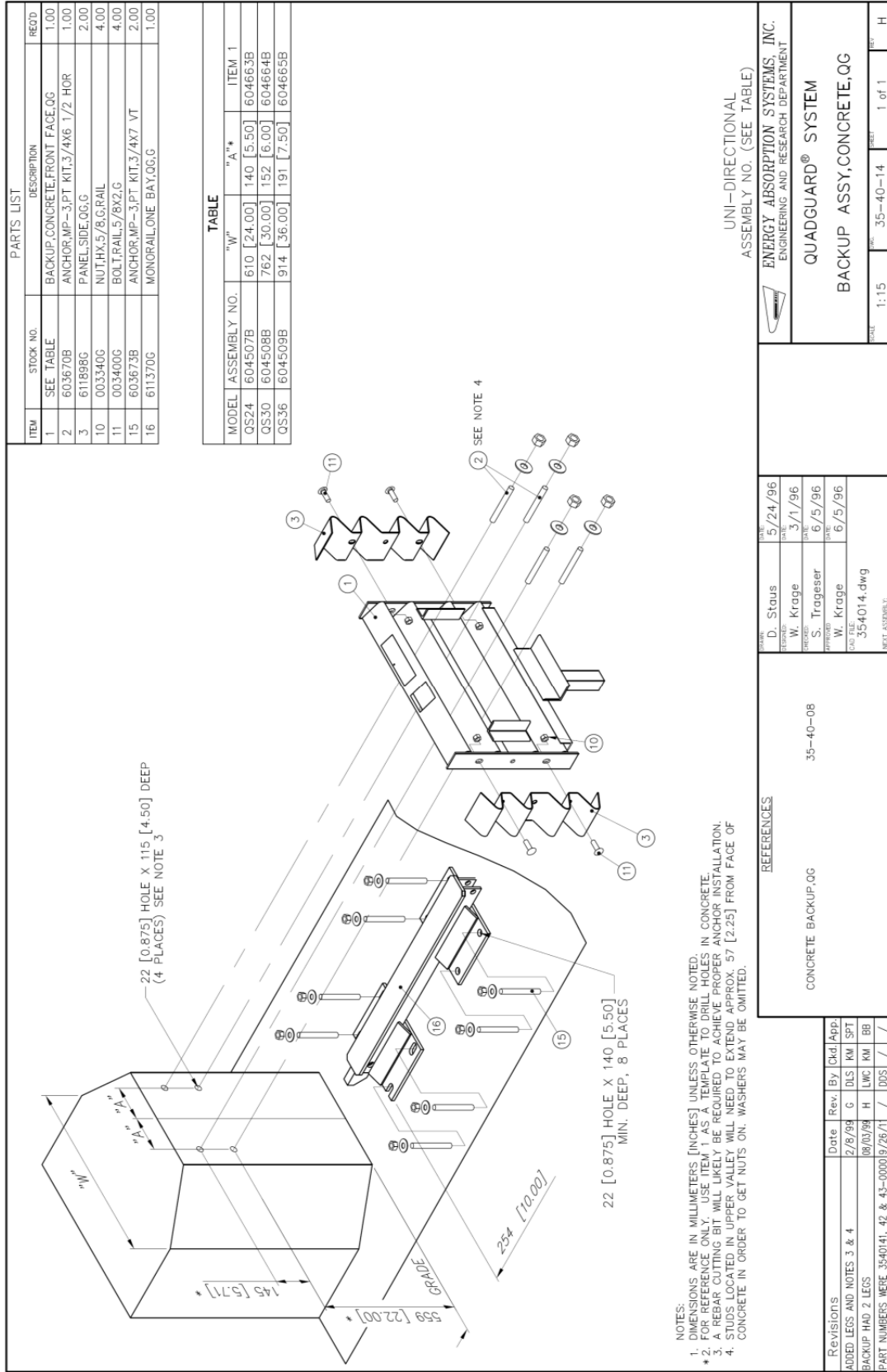

PARTS LIST			
ITEM	STOCK NO.	DESCRIPTION	REQD.
1	SEE TABLE	BACKUP CONCRETE, FRONT FACE, QG	1.00
2	6036708	ANCHOR, MP-3, PT. KIT, 3/4X6 1/2 HOR	1.00
3	611898G	PANEL, SIDE, QG, G	2.00
10	003340G	NUT, HX, 5/8, G, RAIL	4.00
11	003400G	BOLT, RAIL, 5/8X2, G	4.00
15	603673B	ANCHOR, MP-3, PT. KIT, 3/4X7 VT	2.00
16	611370G	MONORAIL, ONE BAY, QG, G	1.00

TABLE				
MODEL	ASSEMBLY NO.	"W"	"A"*	ITEM 1
QS24	604507B	610 [24.00]	140 [5.50]	604663B
QS30	604508B	762 [30.00]	152 [6.00]	604664B
QS36	604509B	914 [36.00]	191 [7.50]	604665B

NOTES:
 1. DIMENSIONS ARE IN MILLIMETERS [INCHES] UNLESS OTHERWISE NOTED.
 * 2. FOR REFERENCE ONLY. USE ITEM 1 AS A TEMPLATE TO DRILL HOLES IN CONCRETE.
 3. A REBAR CUTTING BIT WILL LIKELY BE REQUIRED TO ACHIEVE PROPER INSTALLATION.
 4. STUDS LOCATED IN UPPER VALLEY WILL NEED TO EXTEND APPROX. 57 [2.25] FROM FACE OF CONCRETE IN ORDER TO GET NUTS ON. WASHERS MAY BE OMITTED.

DESIGNED BY	D. Staus	DATE	5/24/96
CHECKED BY	W. Krage	DATE	3/1/96
APPROVED BY	S. Trageser	DATE	6/5/96
CAD FILE	W. Krage	DATE	6/5/96
PROJECT NO.	35-4014.dwg		
NEXT ASSEMBLY:			

REFERENCES	CONCRETE BACKUP, QG	35-40-08
------------	---------------------	----------

UNI-DIRECTIONAL ASSEMBLY NO. (SEE TABLE)	ENERGY ABSORPTION SYSTEMS, INC. ENGINEERING AND RESEARCH DEPARTMENT
QUADGUARD® SYSTEM	BACKUP ASSY, CONCRETE, QG
SCALE: 1:15	FIG. NO. 35-40-14
	1 of 1

QuadGuard® Backup Assembly, Concrete

DWG 354014

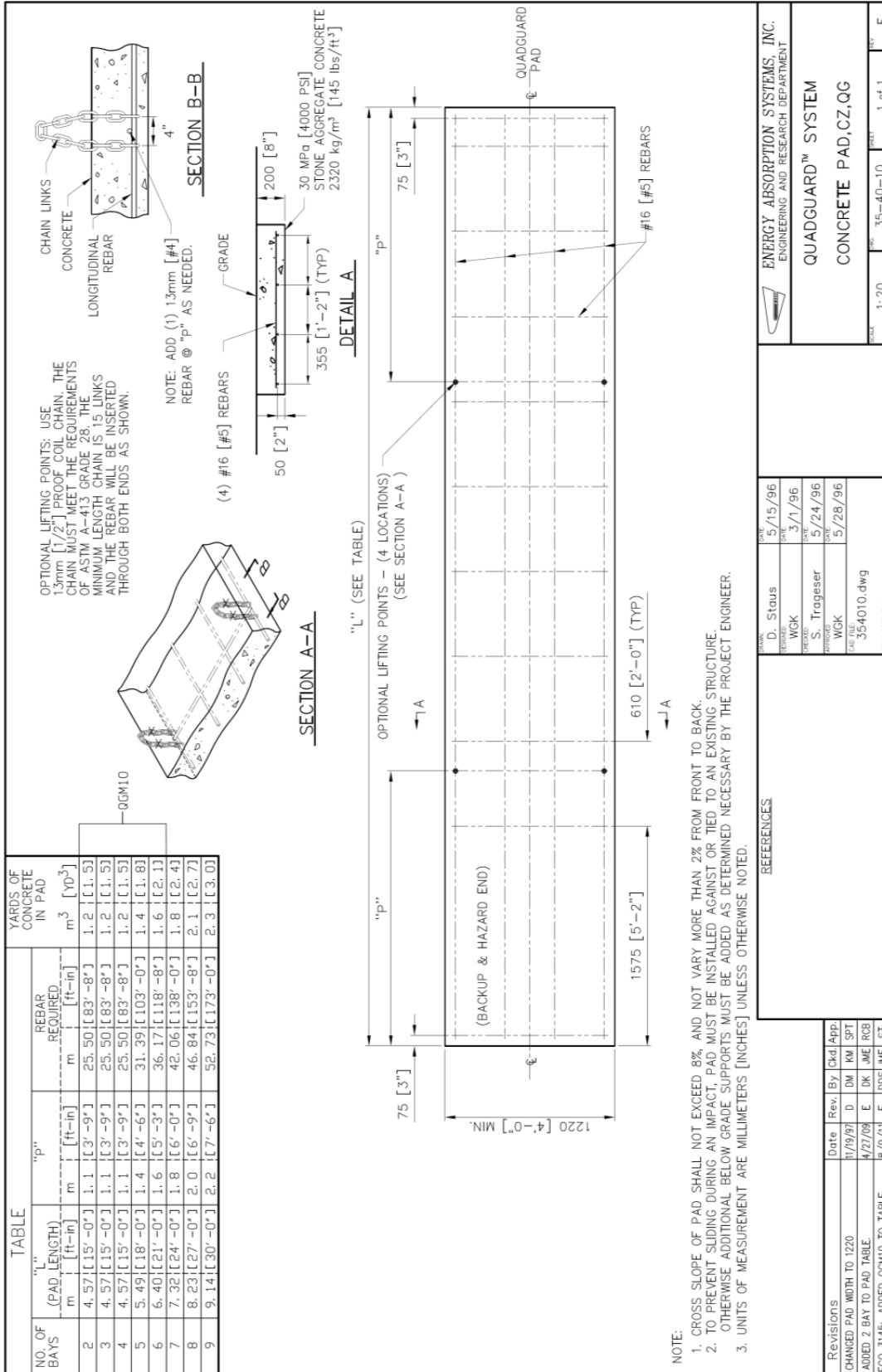

QuadGuard® Concrete Pad, CZ

- NOTE:
- CROSS SLOPE OF PAD SHALL NOT EXCEED 8% AND NOT VARY MORE THAN 2% FROM FRONT TO BACK.
 - TO PREVENT SLIDING DURING AN IMPACT, PAD MUST BE INSTALLED AGAINST OR TIED TO AN EXISTING STRUCTURE. OTHERWISE ADDITIONAL BELOW GRADE SUPPORTS MUST BE ADDED AS DETERMINED NECESSARY BY THE PROJECT ENGINEER.
 - UNITS OF MEASUREMENT ARE MILLIMETERS [INCHES] UNLESS OTHERWISE NOTED.

TABLE 1					PARTS LIST					
ASSEMBLY NO.	TOTAL RAIL LENGTH	*ITEM 1	*ITEM 2	*ITEM 3	*ITEM 5	NO. OF BAYS	ITEM	STOCK NO.	DESCRIPTION	REQ'D
611367B	0	0	0	0	0	1	1	611370G	MONORAIL ONE BAY, O.G.G	*
611332B	915 [36.0]	1	0	0	2	2	2	611375G	MONORAIL TWO BAYS, O.G.G	*
611334B	1830 [72.0]	0	1	0	3	3	3	611379G	MONORAIL THREE BAYS, O.G.G	*
611340B	2745 [108.1]	0	0	1	4	4	4	608136G	END CAP MONORAIL O.G.G	1.00
611345B	3660 [144.1]	1	0	1	5	5	5	603673B	ANCHOR MP-3, PT-KIT, 3/4X7, VT	*
611348B	4575 [180.1]	0	1	1	6	6	6	113660G	BOLT, HX, 5/8X3 1/2, 65, G	1.00
611353B	5490 [216.1]	0	0	2	7	7	7	115970G	NUT, HX, 5/8, G	1.00
611354B	6405 [252.1]	1	0	2	8	8	8	118100G	WASHER, LOCK, 5/8, G	1.00
611356B	7320 [288.2]	0	1	2	9	9				
611329B	8235 [324.2]	0	0	3	10	10				
611330B	9150 [360.2]	1	0	3	12	11				
611331B	10065 [396.2]	0	1	3	13	12				

* SEE TABLE

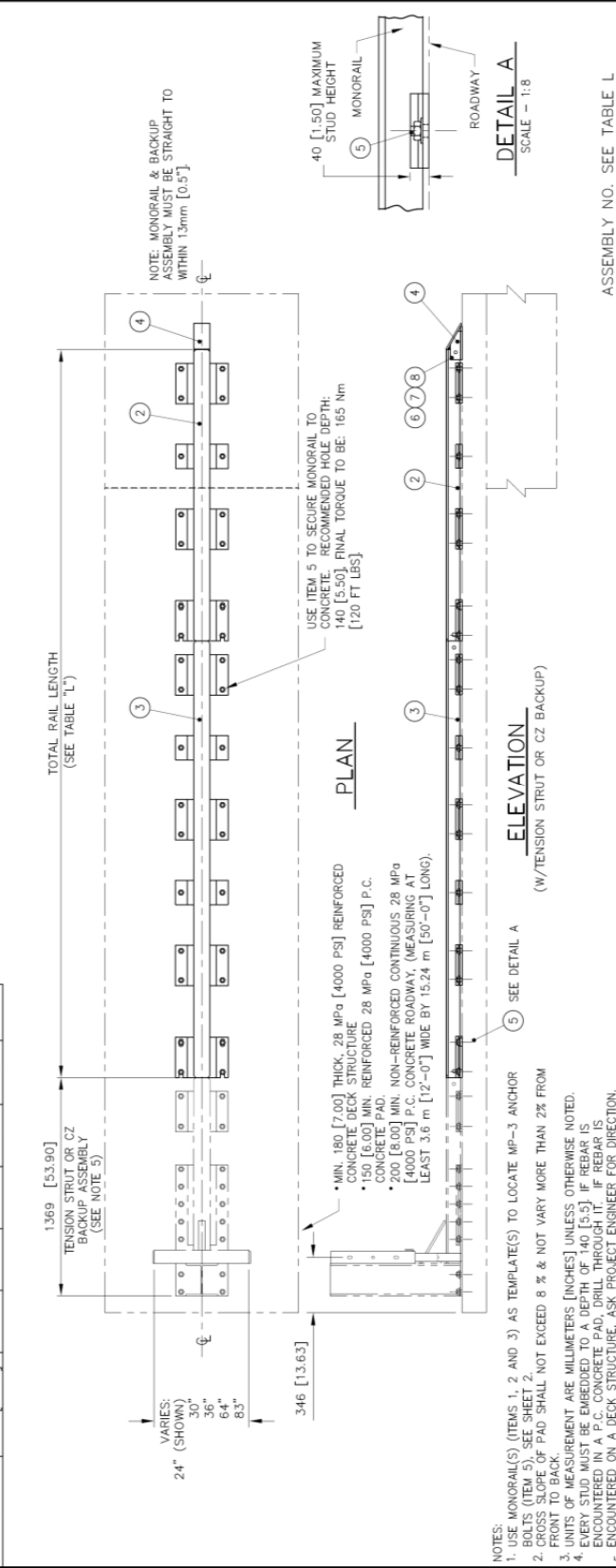

REFERENCES		DATE		BY		APP.	
D. Staus	5-8-96	MHO/JVM	3-1-96	S. Traeger	5/17/96	M. Oberth	5/17/96
NOT ASSEMBLY		354006.dwg		N.T.S.		1 of 3	

ASSEMBLY NO. SEE TABLE L

ENERGY ABSORPTION SYSTEMS, INC.
ENGINEERING AND RESEARCH DEPARTMENT

QUADGUARD® SYSTEM
MONORAIL ASSY, QG

QuadGuard® Monorail Assembly

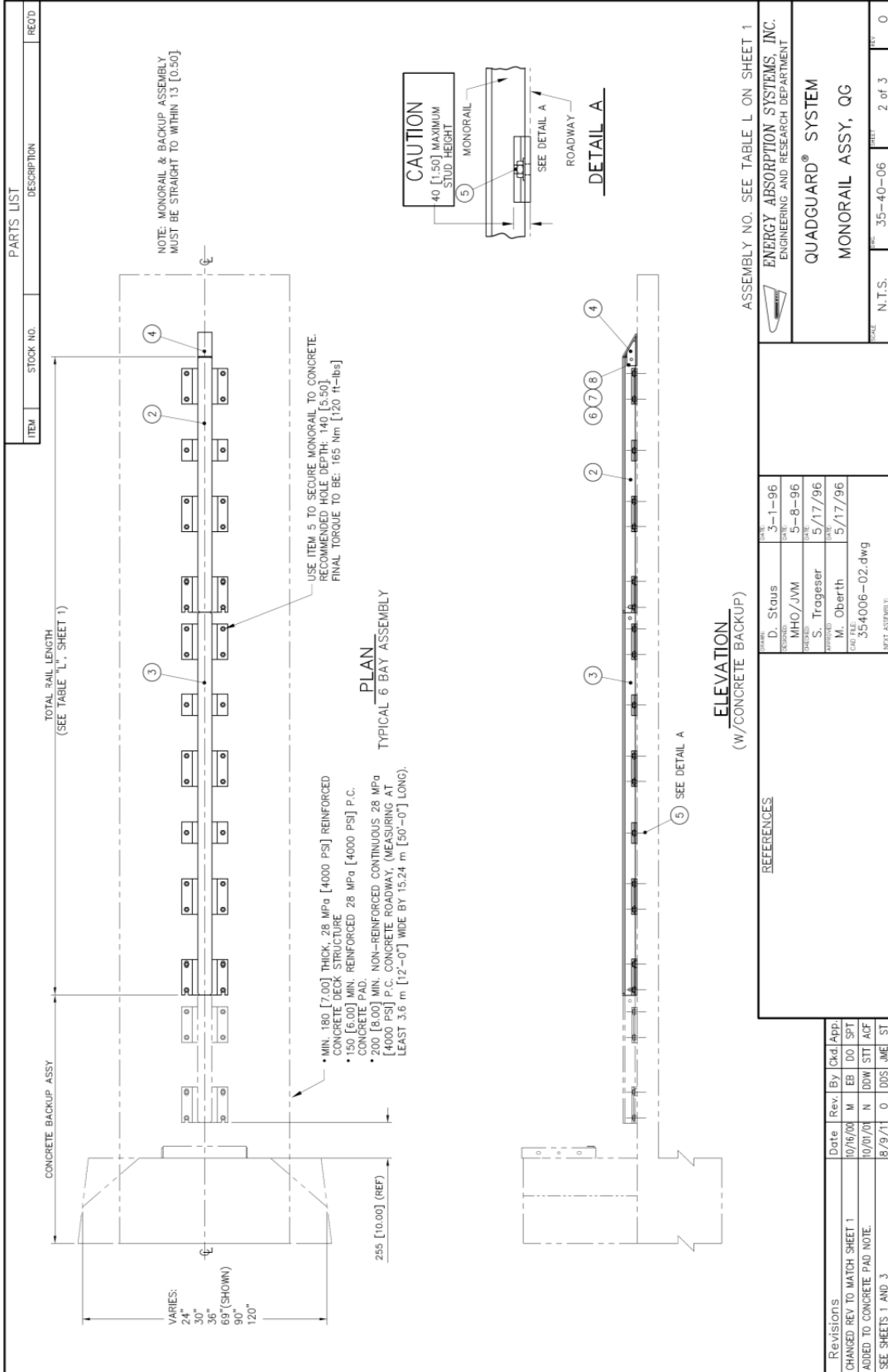

DWG 354006 Sheet 2 of 3

PARTS LIST			
ITEM	STOCK NO.	DESCRIPTION	QTY.
1	611832B	PANEL FENDER,QG	1
2	003400G	BOLT,TRAIL,5/8X2,G	2
3	003340G	NUT,HX,5/8,G,RAIL	2
4	617045G	WASHER MUSHROOM,FORGED,QG,G	1
5	116878G	SCREW,FL,5/8X5,9/8,G,HEX SOCKET	1
6	116970G	NUT,HX,5/8,G	1
7	116552G	WASHER,PLAT,5/8 X 1 3/4, G	1
8	117459B	SPRING,DIE,1 1/4 ODX9/16X1 1/2,B	1

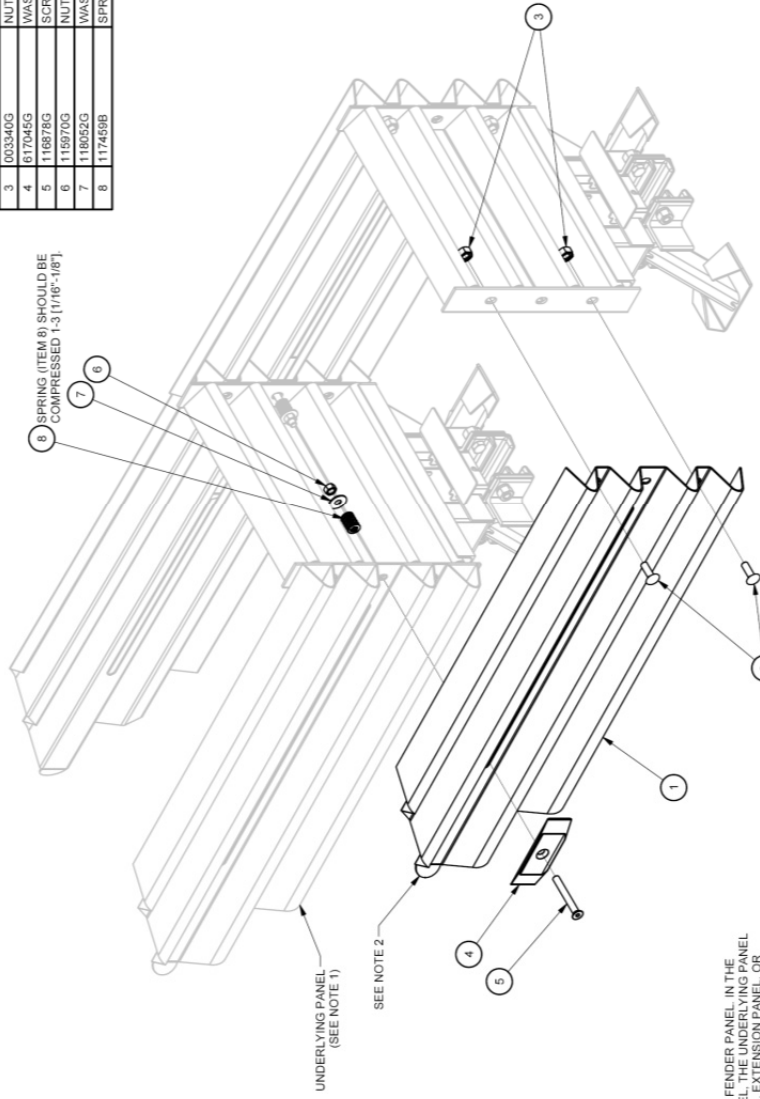

8 SPRING (ITEM 8) SHOULD BE COMPRESSED 1-3 (1/16"-1/8").

UNDERLYING PANEL (SEE NOTE 1)

SEE NOTE 2

- NOTES:
1. UNDERLYING PANEL IS ANOTHER FENDER PANEL. IN THE CASE OF THE LAST FENDER PANEL, THE UNDERLYING PANEL COULD BE A BACKUP SIDE PANEL, EXTENSION PANEL, OR UNDERLYING PANEL.
 2. THERE IS TO BE A 201.781 MAX. GAP BETWEEN ANY FENDER PANEL AND THE UNDERLYING PANEL.

PART NO. 608236B		DATE: 5/21/1996	
ENERGY ABSORPTION SYSTEMS, INC. ENGINEERING AND RESEARCH DEPARTMENT		DATE: 3/7/1996	
FENDER PANEL ASSY,QG		DATE: 6/4/2011	
SCALE: 1 of 1		DATE: 5/21/1996	
DRAWING: 608236		608236.rvw	
REV: 1		J. Espinoza	
REV: 1		JMMHO	
REV: 1		S. Tapscott	
REV: 1		J. Machado	

Revision	Date	Rev	By	Chk	App
DMPHRAIG SPACING WAS FRONT TO FRONT.	11/26/01	H	DDV	JME	DMC
8 WAS 2021611-0000, 7 QTY WAS 4.0	4/22/04	I	DK	JME	AC
REDRAWN, PART NO. WAS 3540949-0000.	5/4/11	-	DK	/	/

DWG 608236

QuadGuard® Fender Panel Assembly

PARTS LIST			
ITEM	STOCK NO.	DESCRIPTION	QTY
1	3540255-0*00	NOSE W/ADJ SUPPORT BRACKET,QG,**	1.00
2	2699341-0000	BOLT,RAIL-5/8X2,G	6.00
3	2704191-0000	NUT,HX,5/8,G,RAIL	6.00
4	2708871-0000	WASHER,BAR,1/8X1 1/4X2,W/HOLE,G	6.00
5	2760251-0000	BRACKET,PULL-OUT	2.00

* 0 INDICATES GRAY
 ** 1 INDICATES YELLOW

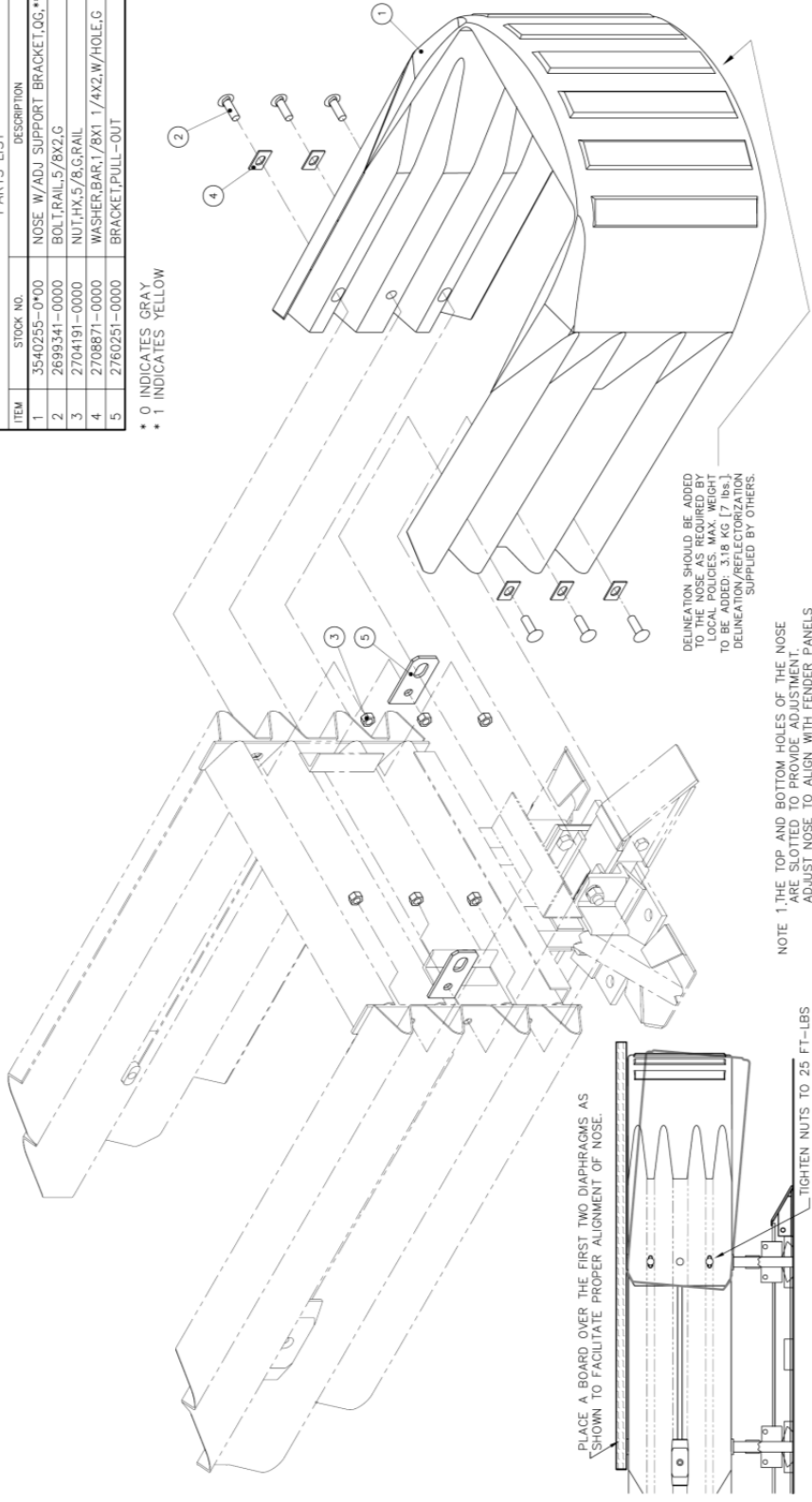

ASSEMBLY NO. 3540050-0100 (YELLOW)
 ASSEMBLY NO. 3540050-0000 (GRAY)

ENERGY ABSORPTION SYSTEMS, INC.
 ENGINEERING AND RESEARCH DEPARTMENT

QUADGUARD® SYSTEM
 NOSE ASSY,QG

DATE	BY	DATE	BY
5/20/96	D. Staus	3/1/96	MHO/JVM
		5/21/96	S. Trageser
		5/22/96	M. Oberth

354005.dwg

DATE	BY	DATE	BY
5/20/96	D. Staus	3/1/96	MHO/JVM
		5/21/96	S. Trageser
		5/22/96	M. Oberth

354005.dwg

Revisions	Date	Rev.	By	Chk.	App.
#1 WAS 3540130-0100	10/12/05	F	DPH	KRM	AJC
ECO 2052 ITEM 1 3540255-000 NOT IMPLEMENTED	5/11/06	G	WML	JME	AJC
ITEM 1 WAS 3540130-0100	5/21/07	H	DK	KRM	AJC

SCALE: 1:10

1 of 1

1 of 1

1 of 1

QuadGuard® System Nose Assembly

DWG 3540050-0000

PARTS LIST			
ITEM	STOCK NO.	DESCRIPTION	REQ'D
1	SEE TABLE A	BACKUP, TS, .0G WIDE, G	1.00
2	611900C	PANEL, SIDE, .0G WIDE, G	2.00
4	113612C	BOLT, HX, 3/8X3 1/2, G2, G, ALL THREAD	16.0
5	115960G	NUT, HX, 3/8, G	16.0
7	118092C	WASHER, LOCK, 3/8, G	16.0
9	603673B	ANCHOR, MP-3, PT-KIT, 3/4X7, VT	3.00
10	003340G	NUT, HX, 5/8, G, RAIL	4.00
11	003400G	BOLT, RAIL, 5/8X2, G	4.00
12	113666G	BOLT, HX, 5/8X4, G5, G	6.00
13	118100G	WASHER, LOCK, 5/8, G	6.00
14	115970G	NUT, HX, 5/8, G	6.00
15	610172C	HINGE PLATE, FENDER, PANEL, .0G, G	2.00
16	615756B	TEL ST 1, 3/4X1 3/4X12GA, HAS, G, 10" LG	4.00
17	615765B	TEL ST 2X2X12GA, HZS, G, 10" LONG	4.00
18	605447B	BRACKET, CARTRIDGE SUPPORT, TS B/U	1.00
19	611266B	LOCKING BAR, CART SUPPORT, .0G	1.00

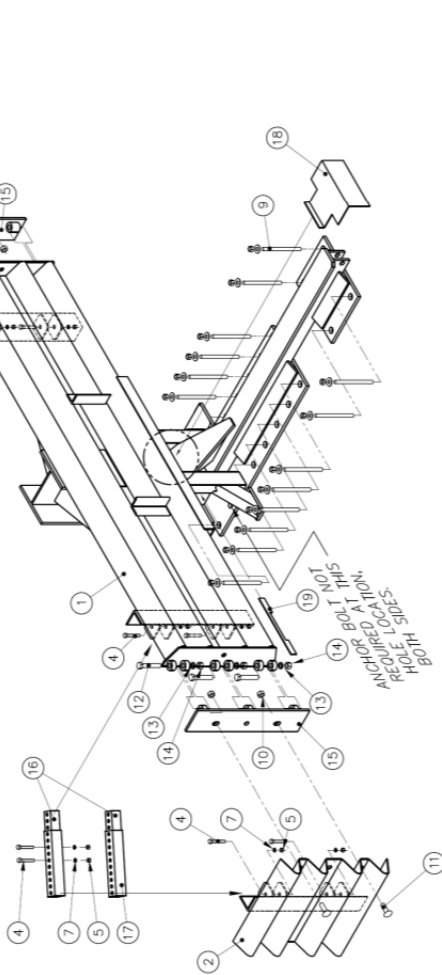

TABLE A

ASSY. NO.	STOCK NO.	DESCRIPTION	WIDTH
604596B	604785B	BACKUP, TS, 64.0G WIDE, G	1620 [64"]
604599B	604789B	BACKUP, TS, 83.0G WIDE, G	2100 [83"]

NOTES:
 1. WHEN TRANSITIONING QUADGUARD SYSTEM TO EXISTING BARRIER REFER TO THE TRANSITION ASSEMBLY DRAWINGS FOR PROPER USE OF SIDE PANEL PART NO. 611898G.

ASSEMBLY NO. SEE TABLE A	
ENERGY ABSORPTION SYSTEMS, INC. ENGINEERING AND RESEARCH DEPARTMENT	
QUADGUARD® SYSTEM	
BACKUP ASSY, TS, .0G WIDE	
SCALE: 1:20	REV: 3540390-0000
	1 of 1
	E

DESIGNED BY: D. Staus	DATE: 7/1/97
REVIEWED BY: J. Machado	DATE: 6/2/97
APPROVED BY: B. Krage	DATE: 7/17/97
APPROVED BY: J. Machado	DATE: 7/17/97
FILE: 3540390-0000.dwg	
REV ASSY: 3540390-0000	

Revisions	Date	Rev.	By	Chd	App.
UPDATED HINGES, ITEM 15 WAS 2790433-0000	12/20/99	D	DK	BB	SPT
ITEM 12 WAS 2699571-0000	12/20/99	E	LWC	BMK	SPT
PART NUMBERS WERE 3540391 & 392-0000	9/27/11	/	DDJ	/	/

REFERENCES

DWG 3540390-0000

QuadGuard® Tension Strut Backup Assembly (Wide)

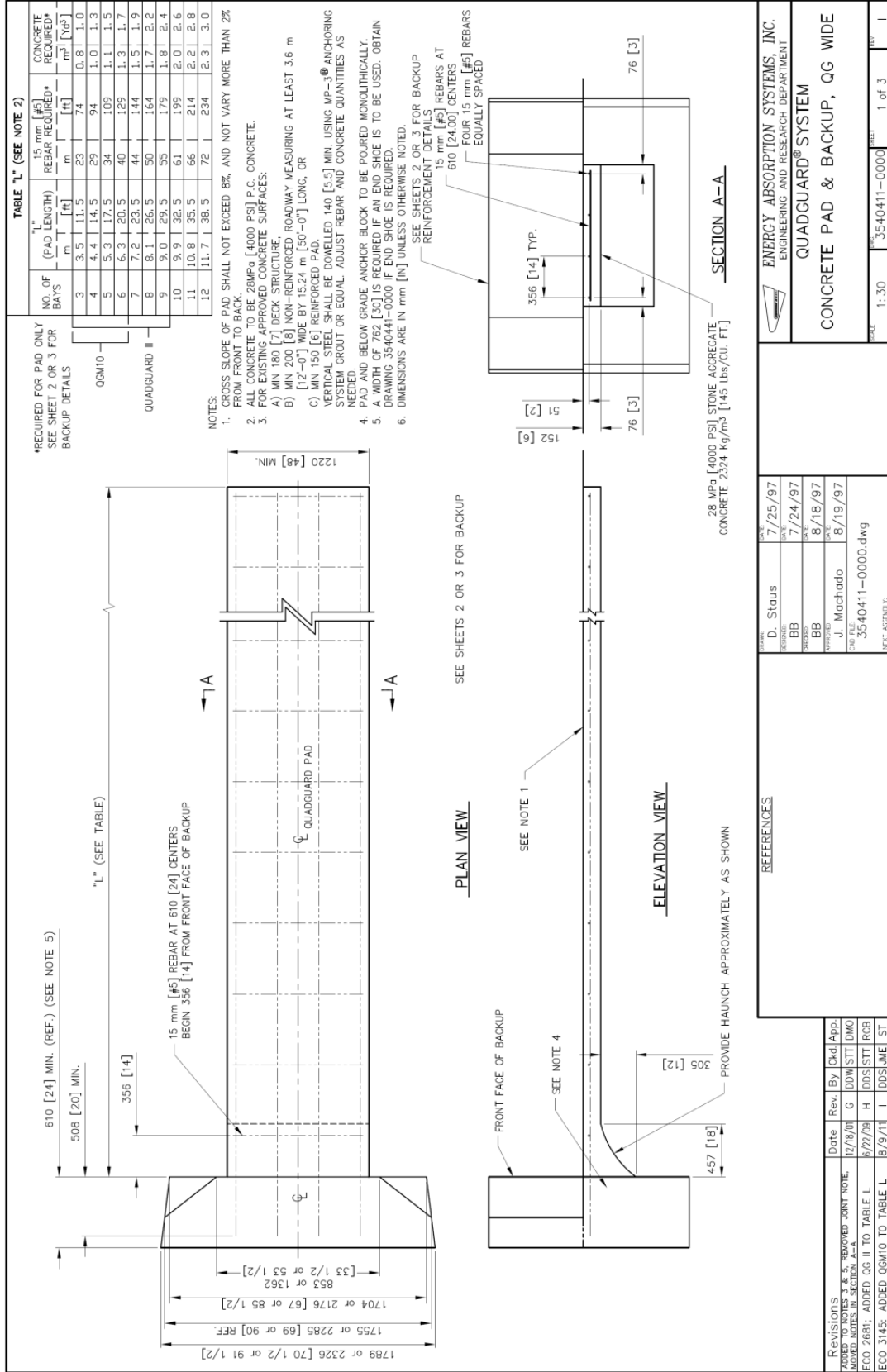

QuadGuard® Concrete Pad & Backup (Wide)

ENERGY ABSORPTION SYSTEMS, INC.
ENGINEERING AND RESEARCH DEPARTMENT
QUADGUARD® SYSTEM
CONCRETE PAD & BACKUP, QG WIDE

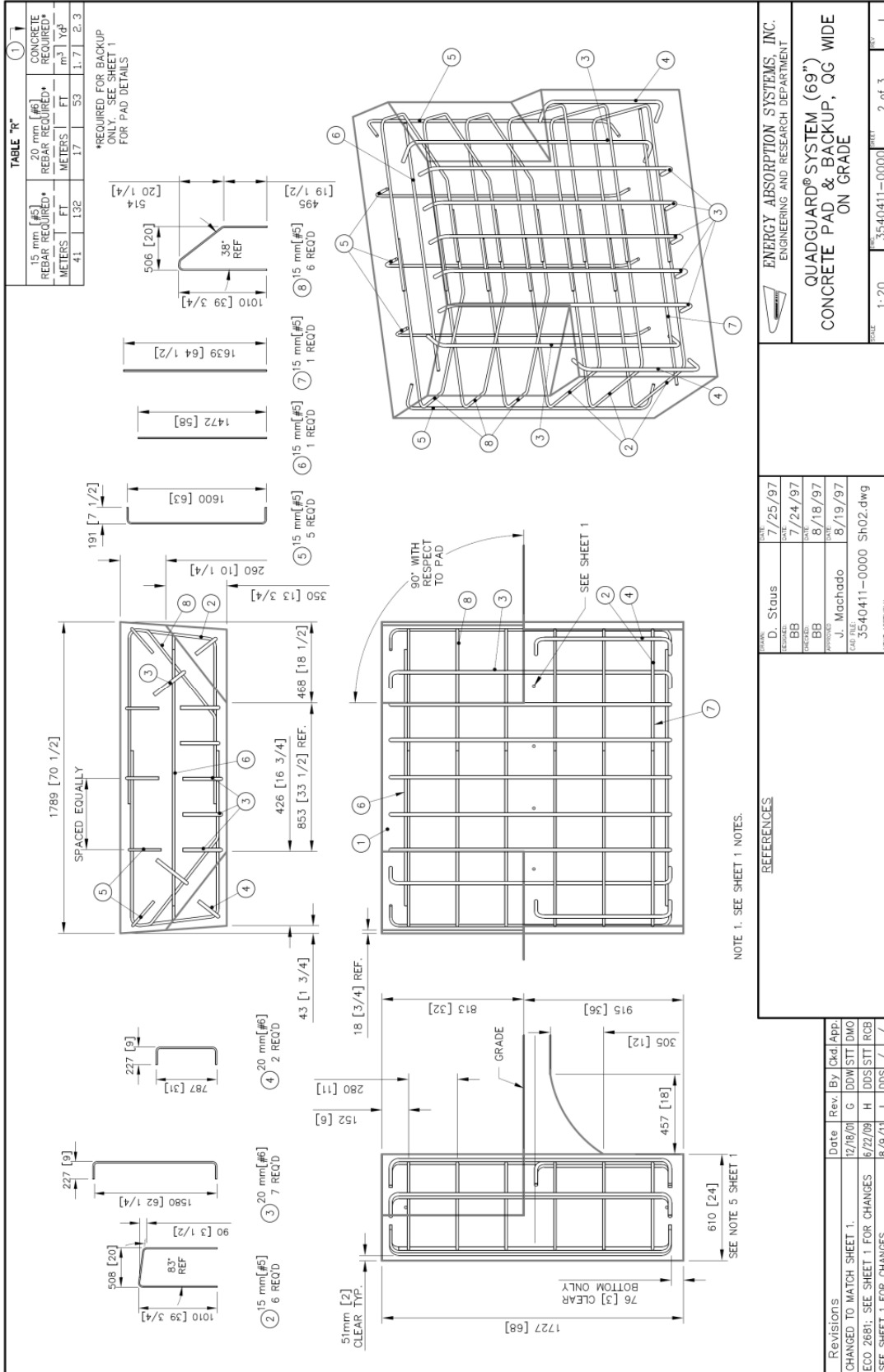

DWG 3540411-0000 Sheet 2 of 3

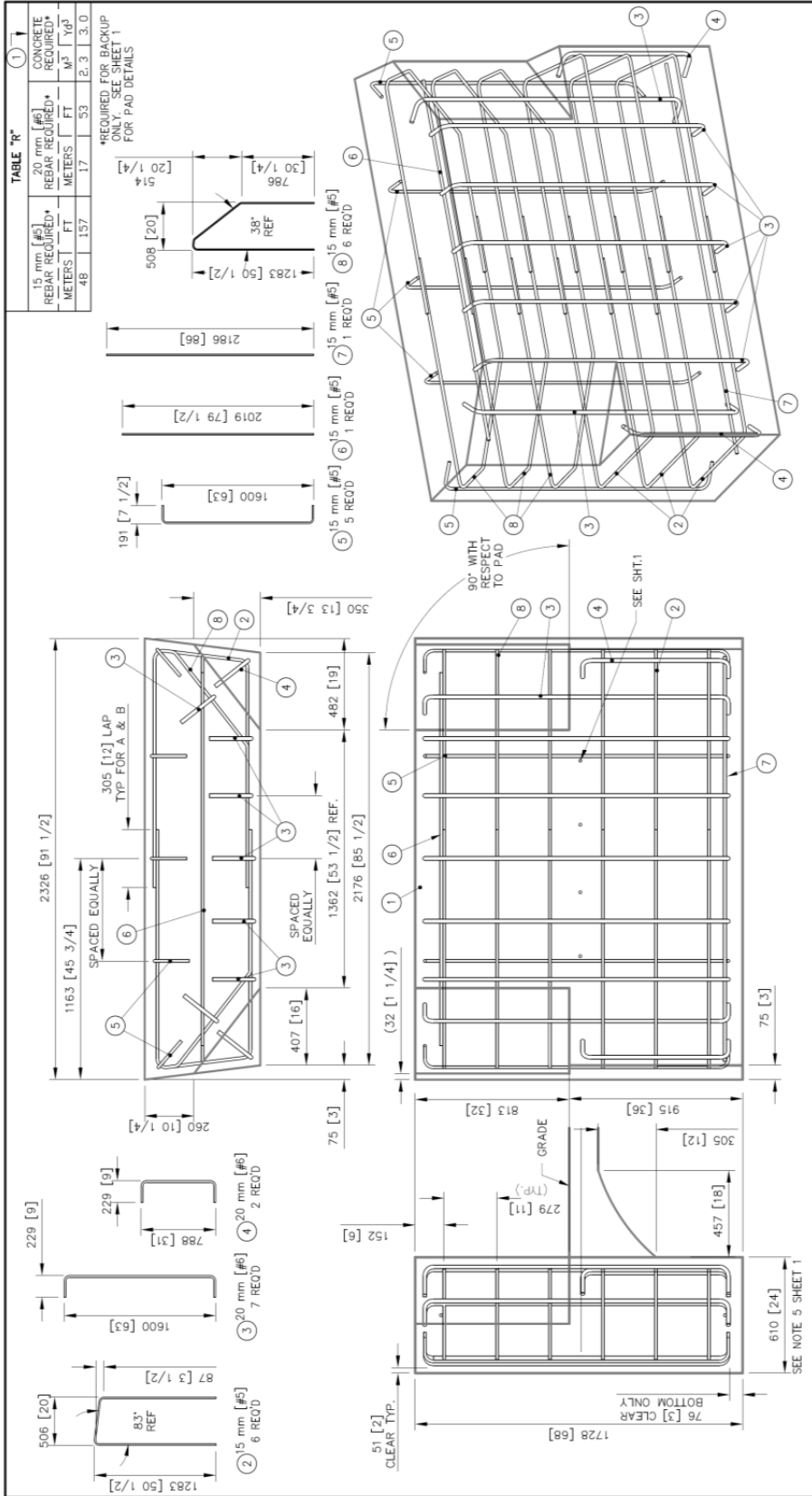

DATE	BY	CHKD	APPD
7/25/97	D. Staus	BB	
7/24/97	BB		
8/18/97	BB		
8/19/97	J. Machado		

DATE: 7/25/97
BY: D. Staus
CHKD: BB
APPD: BB
DATE: 7/24/97
DATE: 8/18/97
DATE: 8/19/97
CAD FILE: 3540411-0000 SH03.dwg
NEXT ASSEMBLY: 3540411-0000

REVISIONS

Revisions	Date	Rev. By	Chk'd	App'd
CHANGED TO MATCH SHEET 1.	12/16/01	G	DDW	SIT/DMO
ECO 2681; SEE SHEET 1 FOR CHANGES	6/22/09	H	DDS	SIT/RCB
SEE SHEET 1 FOR CHANGES	8/9/11	I	DDS	/

ENERGY ABSORPTION SYSTEMS, INC.
ENGINEERING AND RESEARCH DEPARTMENT

QUADGUARD® SYSTEM (90")
CONCRETE PAD & BACKUP, QG WIDE
ON GRADE

SCALE: 1:20
SHEET: 3 of 3

DWG 3540411-0000 Sheet 3 of 3

QuadGuard® Concrete Pad & Backup on Grade (90")

ITEM	STOCK NO.	DESCRIPTION	REQD.
1	SEE TABLE	BACKUP FACE, CONC. ---, OG WIDE, G	1.00
2	603670B	ANCHOR, MP-3, PT KIT, 3/4x6 1/2, HOR	1.00
3	610172B	HINGE PLATE, FENDER PANEL, OG, G	2.00
5	611900B	PANEL, SIDE, OG WIDE, G	2.00
6	115960C	NUT, HX, 3/8, G	16.0
10	113666C	BOLT, HX, 5/8x4, 65, G	6.00
11	118100C	WASHER, LOCK, 5/8, G	6.00
12	603673B	ANCHOR, MP-3, PT KIT, 3/4x7, VT	2.00
13	611370B	MONORAIL, ONE BAY, OG, G	1.00
14	115970C	NUT, HX, 5/8, G	6.00
15	003360C	BOLT, RAIL, 5/8x1 1/4, G	4.00
16	003340C	NUT, HX, 5/8, G, RAIL	4.00
17	615756B	TEL. ST. 1 3/4x1 3/4x12GA, H4S, G, 10" LG	4.00
18	615765B	TEL. ST. 2X2X12GA, H2S, G, 10" LONG	4.00
19	113612C	BOLT, HX, 3/8x3 1/2, G2, G, ALL THREAD	16.0

ASSY. NO.	ITEM 1	DESCRIPTION	WIDTH
604513B	604632B	BACKUP FACE, CONC, 64.0G WIDE, G	16.20 [64"]
604515B	604634B	BACKUP FACE, CONC, 83.0G WIDE, G	21.00 [83"]
617595B	617596B	BACKUP FACE, CONC, 120.0G WIDE, G	30.48 [120"]

22 [0.875] HOLE X 115 [4.50] DEEP,
4 PLACES - SEE NOTE 3

22 [0.875] HOLE X 140 [5.50]
MIN. DEEP, 8 PLACES
USE ITEM 13 AS TEMPLATE

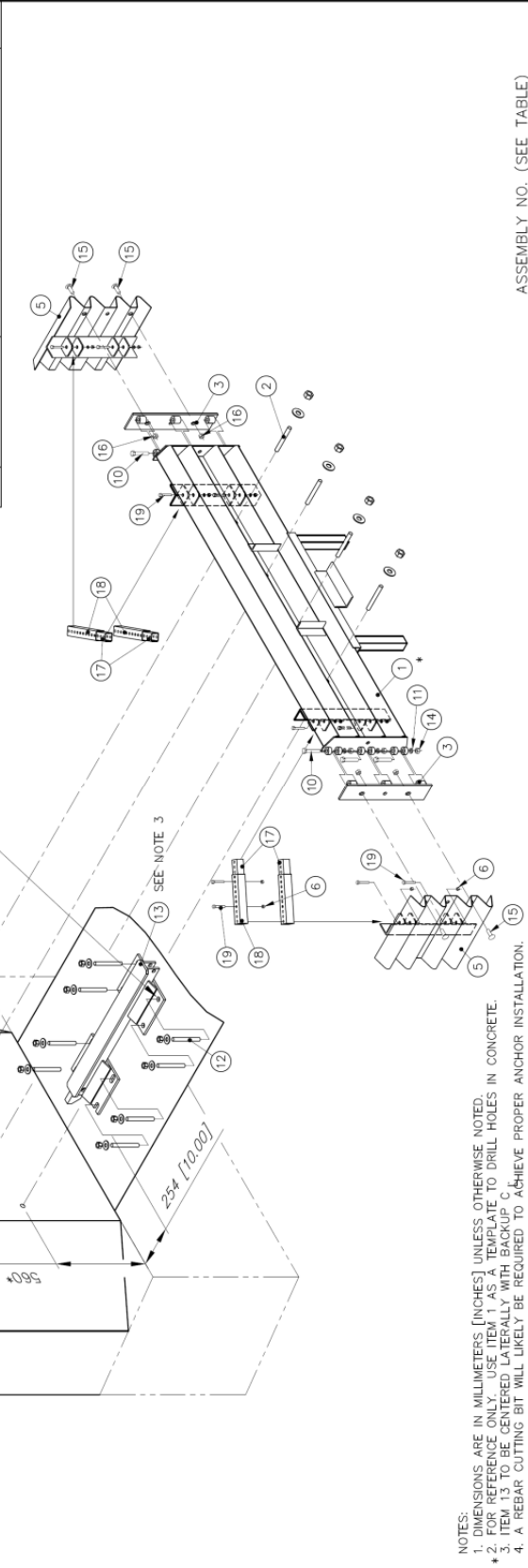

DATE	BY	CHKD	APP.
7/8/97	D. Staus		
5/27/97	J. Machado		
7/17/97	B. Korrow		
7/17/97	S. Trageser		

CONCRETE BACKUP, OG WIDE 35-40-41

REFERENCES

ASSEMBLY NO. (SEE TABLE)

ENERGY ABSORPTION SYSTEMS, INC.
ENGINEERING AND RESEARCH DEPARTMENT

BACKUP ASSY, CONCRETE, ---, OG WIDE

SCALE 1:25

DWG NO. 604513

SHEET 1 of 1

NOTES:

1. DIMENSIONS ARE IN MILLIMETERS [INCHES] UNLESS OTHERWISE NOTED.
2. FOR REFERENCE ONLY. USE ITEM 1 AS A TEMPLATE TO DRILL HOLES IN CONCRETE.
3. ITEM 13 TO BE CENTERED LATERALLY WITH BACKUP C.
4. A REBAR CUTTING BIT WILL LIKELY BE REQUIRED TO ACHIEVE PROPER ANCHOR INSTALLATION.

Date	Rev.	By	Chd	App.
12/20/96	D	LWC	BNK	SPT
05/19/08	E	RCC	STT	AVB
07/08/10	E	RJV	/	/

ITEM 10 WAS 2699571-0000
ADDED 120" BACKUP TO TABLE
MIS. 354000-000 & ADDED ROWMS

QuadGuard® Backup Assembly, Concrete (Wide)

PARTS LIST			
ITEM	STOCK NO.	DESCRIPTION	QTY.
1	SEE TABLE	DIAPHRAGM,OB.G	1
2	119089G	WASHER,LOCK,3/4.G	4
3	113555G	BOLT,HX,3/4X2,G8.G	4
4	811368G	MONORAIL GUIDE,OG.G	2
5	116964G	NUT,HX,3/4",GF,DH	4
6	805446G	BRACKET,CARTRIDGE SUPT,DIAP,FOLDED,OG.G	2
7	810172G	HINGE PLATE,FENDER PANEL,OG.G	2
8	113666G	BOLT,HX,5/8X4,G5.G	6
9	115970G	NUT,HX,5/8.G	6
10	118100G	WASHER,LOCK,5/8.G	6

Table		
ASSEMBLY NO.	DESCRIPTION	ITEM I PART NO.
607173B	DIAPHRAGM ASSY,OG,0673	607766B
607174B	DIAPHRAGM ASSY,OG,0753	607766B
607175B	DIAPHRAGM ASSY,OG,0833	607771B
607176B	DIAPHRAGM ASSY,OG,0913	607773B
607177B	DIAPHRAGM ASSY,OG,0993	607775B
607145B	DIAPHRAGM ASSY,OG,1073	607777B
607146B	DIAPHRAGM ASSY,OG,1153	607780B
607148B	DIAPHRAGM ASSY,OG,1233	607783B
607149B	DIAPHRAGM ASSY,OG,1273	607787B
607150B	DIAPHRAGM ASSY,OG,1313	607788B
607152B	DIAPHRAGM ASSY,OG,1393	607796B
607151B	DIAPHRAGM ASSY,OG,1473	607792B
607156B	DIAPHRAGM ASSY,OG,1513	607800B
607157B	DIAPHRAGM ASSY,OG,1553	607801B
607158B	DIAPHRAGM ASSY,OG,1593	607804B
607169B	DIAPHRAGM ASSY,OG,1729	607806B
607100B	DIAPHRAGM ASSY,OG,1793	607808B
607162B	DIAPHRAGM ASSY,OG,1873	607811B
607163B	DIAPHRAGM ASSY,OG,1953	607813B
607164B	DIAPHRAGM ASSY,OG,2033	607815B

NOTE:
1. QUADGUARD II AND OGM10 REQUIRE SHIM KIT.
SEE DRAWING 614050.

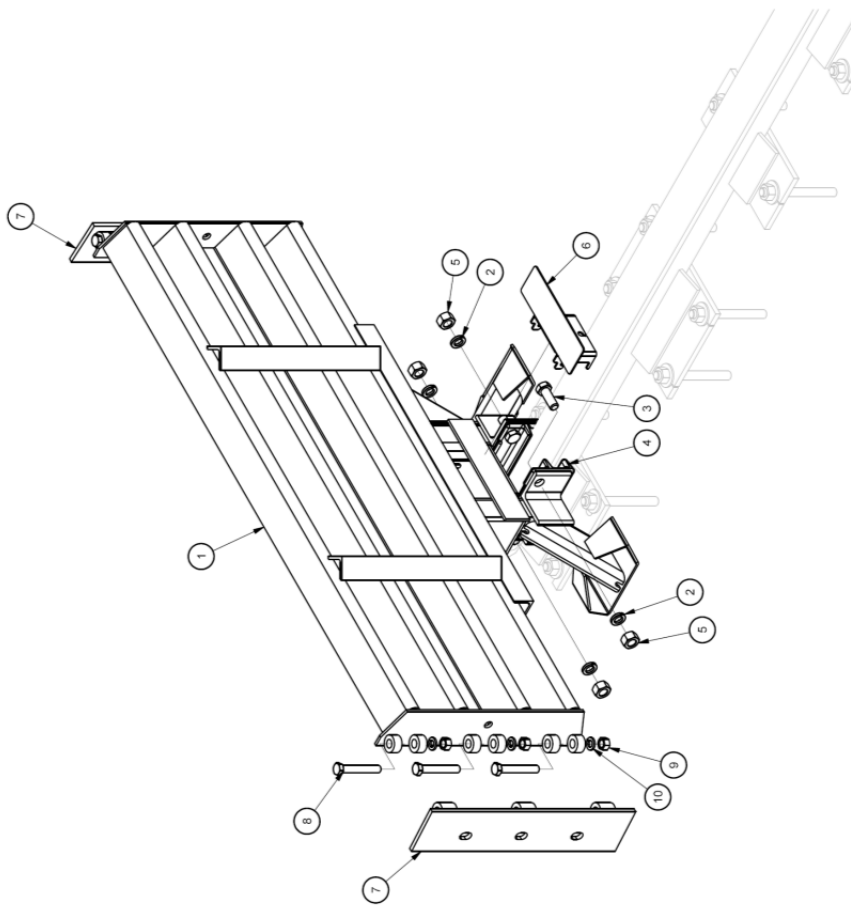

ASSEMBLY NO. SEE TABLE

ENERGY ABSORPTION SYSTEMS, INC.
ENGINEERING AND RESEARCH DEPARTMENT

DIAPHRAGM ASSY, OG, WIDE

DATE	5/12/1997
DESIGNED BY	J. Machado
DATE	5/13/1997
DESIGNED BY	KRM
DATE	7/21/1997
DESIGNED BY	J. Machado
DATE	7/7/1997
DESIGNED BY	

607173.BW

Revision	Date	Rev	By	Chk	App.
UPDATED VIEW OF ITEM 6 (ECO 2495)	10/29/04	K	WWW	/	/
ADDED NOTE & SEE SHEET 2 (ECO 2663)	5/27/09	L	WWW	STT	MJB
3145(REVISED NOTE,ASSY NO. WAS 346346-	8/10/11	M	DDC	JME	ST

TITLE	1.9	DRAWING	607173	SHEET	1	of	2	REV.	M
-------	-----	---------	--------	-------	---	----	---	------	---

QuadGuard® Diaphragm Assembly (Wide)

DWG 607173 Sheet 1 of 2

PARTS LIST			
ITEM	STOCK NO.	DESCRIPTION	QTY.
1	611832B	PANEL FENDER, QG	1
2	617045G	WASHER MUSHROOM, FORGED, QG, G	1
3	116879G	SCREW FL. 5/8X8 1/2, G8, G, SOCKET	1
4	117458G	SPRING, DIE, 1 1/2, OD, X3/4X6, GALV	1
6	003340G	NUT, HX, 5/8, G, RAIL	3
9	003400G	BOLT, RAIL, 5/8X2, G	2

TWO FENDER PANEL ASSEMBLIES REQUIRED PER BAY.

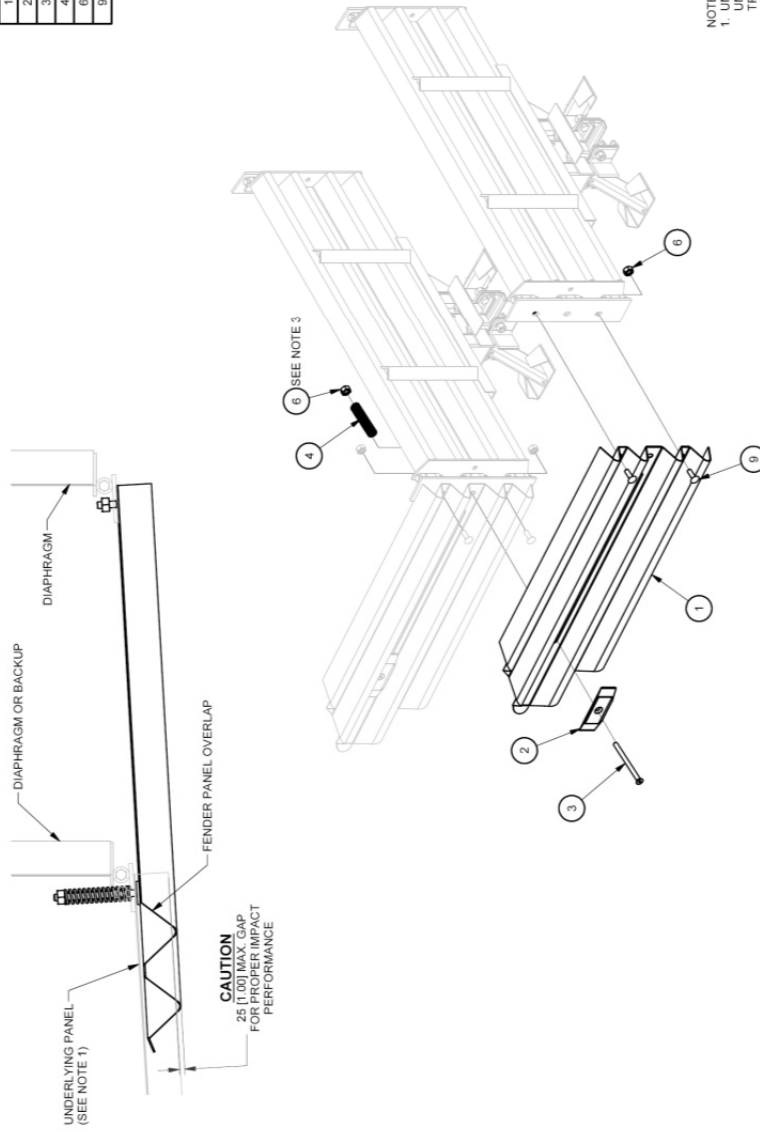

NOTES:
 1. UNDERLYING PANEL IS A FENDER PANEL IF ATTACHED TO A DIAPHRAGM.
 2. UNDERLYING PANEL IS A BACKUP SIDE PANEL IF FENDER PANEL OR TRANSITION PANEL IS ATTACHED TO THE BACKUP.
 3. UNITS OF MEASUREMENT ARE MILLIMETERS (INCHES) UNLESS OTHERWISE NOTED.
 4. TIGHTEN NUT UNTIL IT REACHES END OF THREADS.

Revision	Date	Rev	By	Chk	App.
REVISED PLAN VIEW	10/04/01	H	RS	DMO	FP
ADDED NOTE 3	3/26/02	I	DDW	DMO	SPT
PART NUMBER WAS 346375-0000	8/20/11	/	DDG	/	/

DESIGNED BY	D. Staus	DATE	6/12/1997
CHECKED BY	J. Machado	DATE	4/10/1997
DESIGNED BY	KRM	DATE	7/7/1997
CHECKED BY	J. Machado	DATE	7/7/1997
PART NO.	608241-RW		

ASSEMBLY NO. 608241B



ENERGY ABSORPTION SYSTEMS, INC.
 ENGINEERING AND RESEARCH DEPARTMENT

QuadGuard - Wide System
 FENDER PANEL ASSEMBLY

SCALE	1 - 16	SHEET	608241	1	of	1
-------	--------	-------	--------	---	----	---

QuadGuard® Fender Panel Assembly (Wide)

DWG 608241

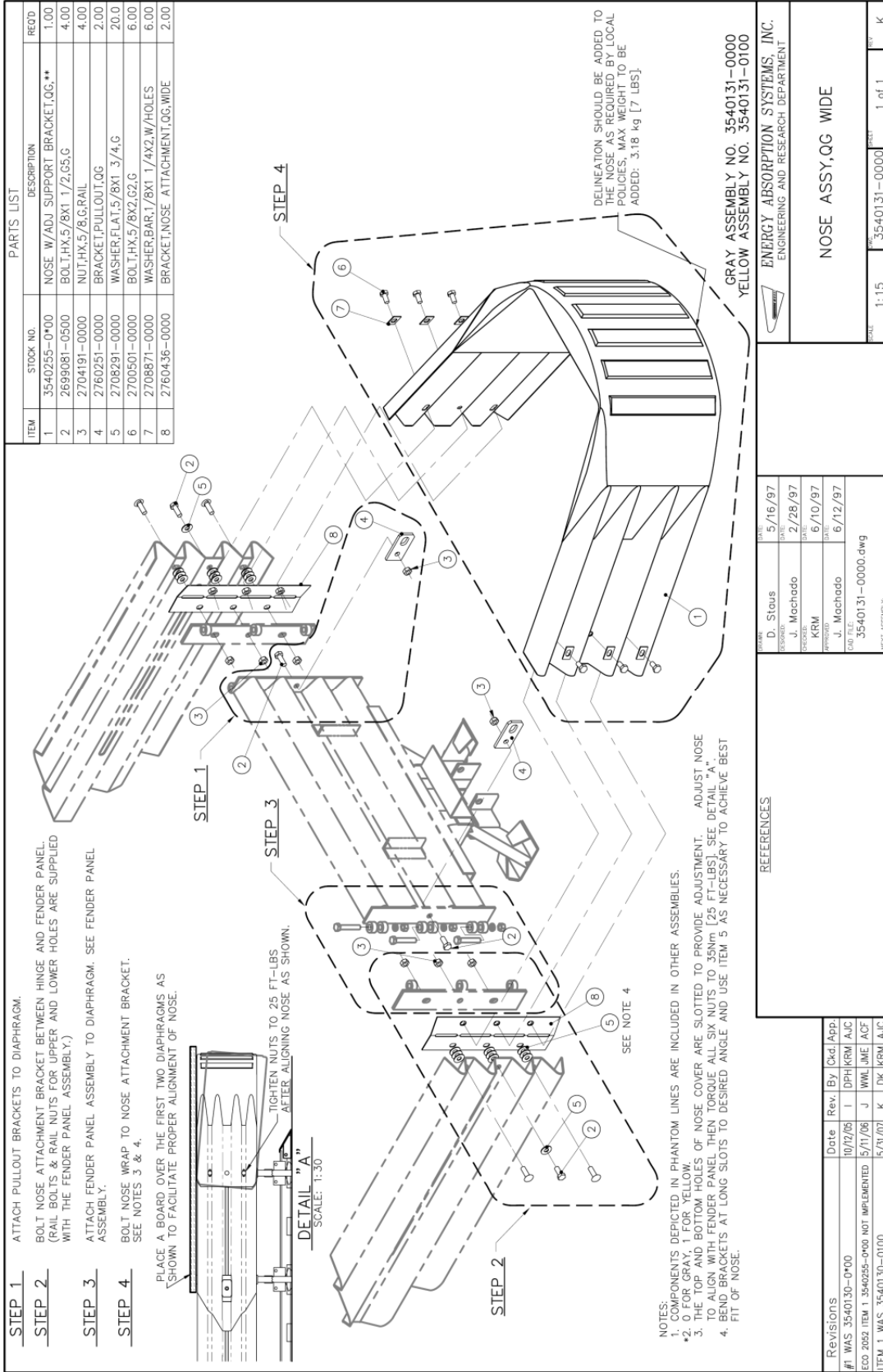

ITEM	STOCK NO.	DESCRIPTION	REQ'D
1	3540255-0*00	NOSE W/ADJ SUPPORT BRACKET,QG,**	1.00
2	2699081-0500	BOLT,HX.5/8X1.1/2,G5,G	4.00
3	2704191-0000	NUT,HX.5/8,G,RAIL	4.00
4	2760251-0000	BRACKET,PULLOUT,QG	2.00
5	2708291-0000	WASHER,FLAT.5/8X1.3/4,G	20.0
6	2700501-0000	BOLT,HX.5/8X2,G2,G	6.00
7	2708871-0000	WASHER,BAR.1/8X1.1/4X2,W/HOLES	6.00
8	2760436-0000	BRACKET,NOSE ATTACHMENT,QG,WIDE	2.00

Revisions	Date	Rev.	By	Chg. App.
#1 WAS 3540130-0*00	10/12/05	1	DPH/KRM/AJC	
ECO 2002 ITEM 1 3540255-0*00 NOT IMPLEMENTED	5/11/06	J	WML/LME/ACF	
ITEM 1 WAS 3540130-0100	5/13/07	K	DK/KRM/AJC	

DATE	BY	DATE	BY
5/16/97	D. Staus	5/16/97	D. Staus
2/28/97	J. Machado	2/28/97	J. Machado
6/10/97	KRM	6/10/97	KRM
6/12/97	J. Machado	6/12/97	J. Machado

DESIGNER: D. Staus
CHECKED: J. Machado
DRAWN: KRM
APPROVED: J. Machado
DWG FILE: 3540131-0000.dwg
NEXT ASSEMBLY:

REV	DATE	DESCRIPTION
1	1:15	3540131-0000

DWG 3540131-0000

QuadGuard® Nose Assembly (Wide)

ITEM	STOCK NO.	DESCRIPTION	PARTS LIST								
			DESCRIPTION			BAYS			RECD		
1	2700731-0500	ROD, THREADED, 3/4x18, G5, G	32	38	46	52	58	66	72	9	
2	2704341-0000	NUT, HX, 3/4, G, GR, DH	32	38	46	52	58	66	72		
3	2708081-0000	WASHER, FLAT, 3/4x2, Hvy, G	32	38	46	52	58	66	72		
4	3525100-0000	MP-3, QUART, PACKAGE	8	10	12	13	15	17	18		
5	2760231-0000	BRACKET, LIFTING, OG, CZ	4	4	4	4	4	4	4		
6	DELETED		-	-	-	-	-	-	-		
7	2699571-0000	BOLT, HX, 5/8x3 1/2, G5, G	1	1	2	2	2	2	3		
8	2704141-0000	NUT, HX, 5/8, G	1	1	2	2	2	2	3		
9	2708231-0000	WASHER, LOCK, 5/8, G	1	1	2	2	2	2	3		
10	3540242-0000	INST., OG CZ ANCHOR/LIFT KIT	1	1	1	1	1	1	1		
11	2735492-0000	LABEL, GRATE, OG CZ/LIFT KIT	1	1	1	1	1	1	1		

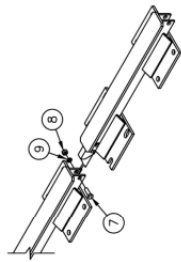

MONORAIL ATTACHMENT
SCALE - 1:25

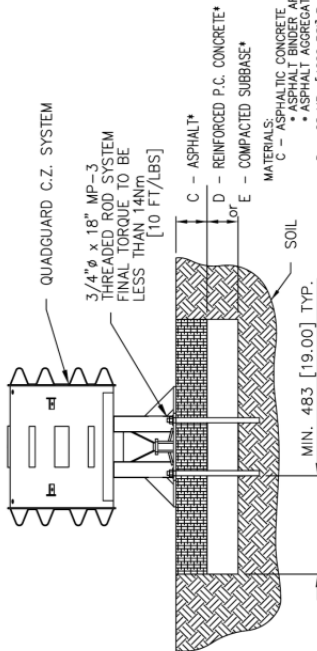

SECTION A-A
REFER TO QUADGUARD CZ ANCHORING SYSTEM
INSTALLATION & SAFETY INSTRUCTIONS FOR
FURTHER INFORMATION

MATERIALS:
C - ASPHALTIC CONCRETE
D - REINFORCED P.C. CONCRETE*
E - COMPACTED SUBBASE*
* ASPHALT FINDER, AR-4000
* ASPHALT AGGREGATE 3/4" (19mm) MAX., MED A B
D - 28 MPa (4000 PSI) P. C. CONCRETE
E - SUBBASE, PREPARED & COMPACTED
* CLASS 2
* 95% COMPACTION
MINIMUM LAYER

DEPTH COMBINATION		RECD STUD LENGTH	
"C"	"D"	"E"	"F"
76mm [3"]	152mm [6"]	180mm [7"]	460mm [18"]
152mm [6"]	305mm [12"]	180mm [7"]	460mm [18"]
203mm [8"]	457mm [18"]	180mm [7"]	460mm [18"]

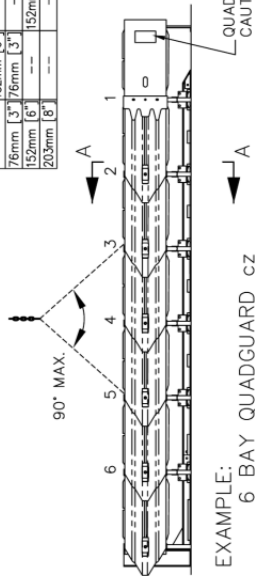

EXAMPLE:
6 BAY QUADGUARD CZ
SCALE - 1:50

TO MOVE SYSTEM:

1. Verify monorail sections are bolted together.
2. Attach two lifting brackets each on diaphragms listed (four brackets total). See example.
3. Minimum sling length 3 meters (9 ft). Use fixed equal length slings.
4. Free unit from anchor bolts & grout prior to lifting the system. To accomplish this, start at the nose of the system and use pry bars to gradually raise the system off of the studs. Place blocks such as 2x4's under the monorail and work down the length of unit until the unit is completely free of the studs.
5. Lift the system to new location and re-anchor.
6. ANCHOR SYSTEM FOR PROPER IMPACT PERFORMANCE. Use MP-3 polyester anchor system, supplied by Energy Absorption Systems, or approved equal. QuadGuard cz Systems installed on asphalt must be inspected to ensure the anchors are still properly set following each impact. Re-anchor as necessary. See drawing 35-40-06.

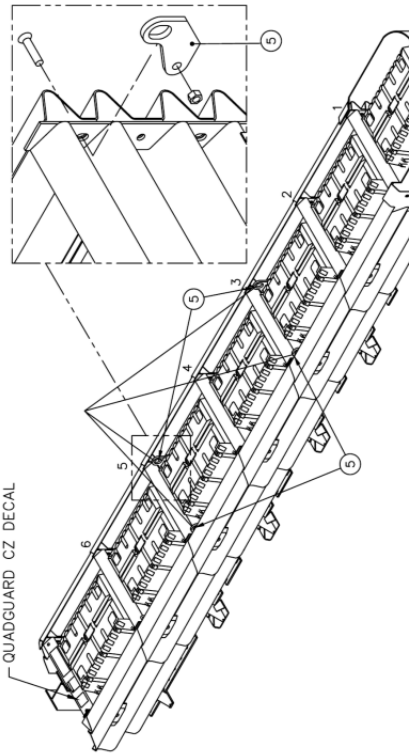

ITEMS 5 & 6 LOCATION CHART	
NO. OF BAYS (DIAPHRAGMS)	ASSEMBLY NUMBER
3	3540243-0000
4	3540244-0000
5	3540245-0000
6	3540246-0000
7	3540247-0000
8	3540248-0000
9	3540249-0000

SCALE - 1:30

QUADGUARD CZ
CAUTION DECAL
* SEE CHART
ASSY NO. 354024*-0000

DATE:	10/7/96	DATE:	10/15/96
BY:	D. Staus	BY:	B. Burgess
DESIGNED:	B. Burgess	APPROVED:	K. Mortensen
REVISIONS:		DATE:	10/15/96
REVISED TO SHOW NOSE BELT		DATE:	10/15/96
ITEM 4 WAS 3525210-0000		DATE:	10/15/96
REVISED TO SHOW NOSE BELT		DATE:	10/15/96

ENERGY ABSORPTION SYSTEMS, INC.
ENGINEERING AND RESEARCH DEPARTMENT
QuadGuard® SYSTEM
CZ ANCHOR/LIFTING KIT, QG,
(3-9 BAYS)
Instruction No.
3540242-0000
AS NOTED 35-40-24 1 of 2 H

QuadGuard® CZ Anchor/Lifting Kit (3-9 Bays)

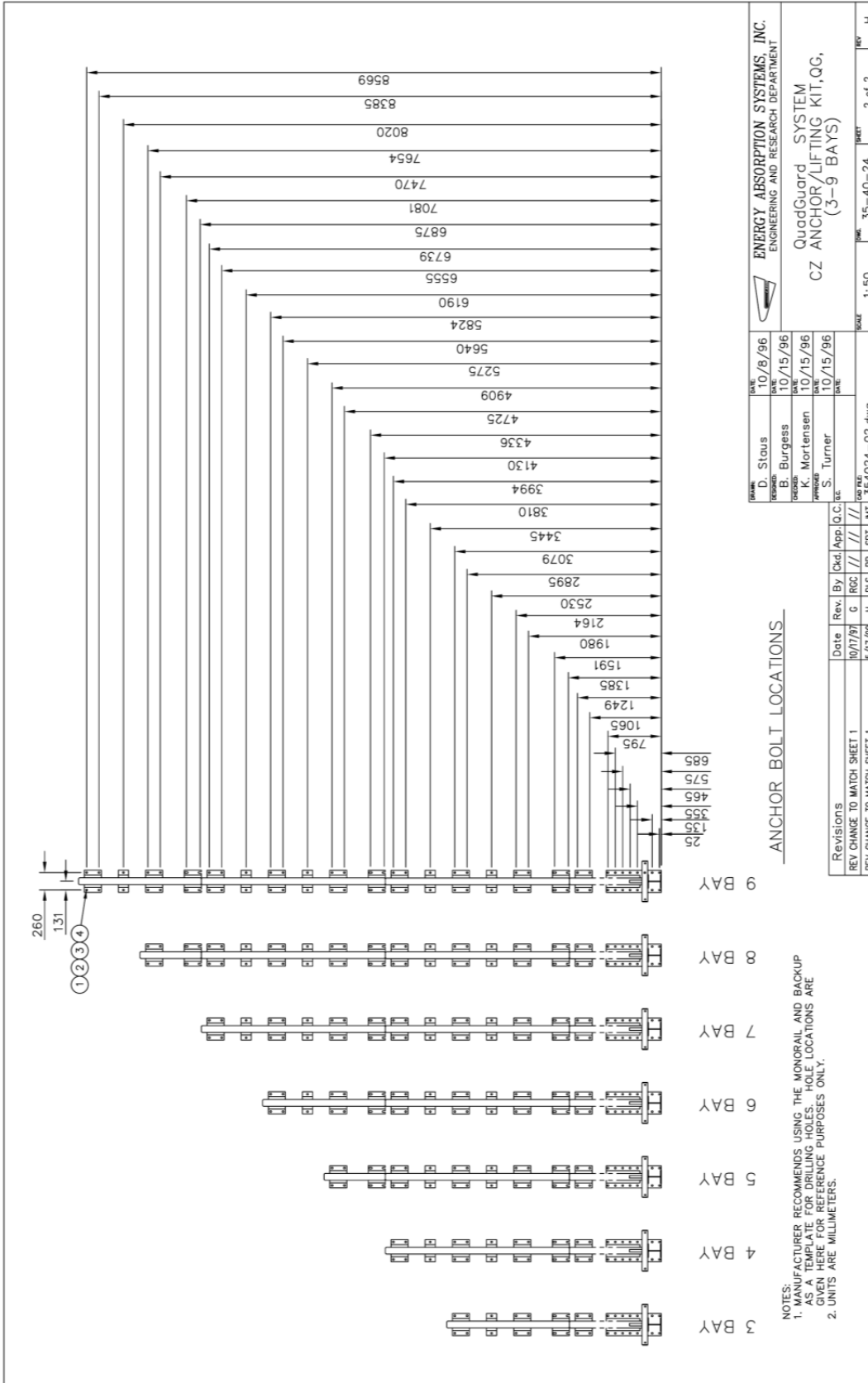

DWG 3540243-0000 Sheet 2 of 2

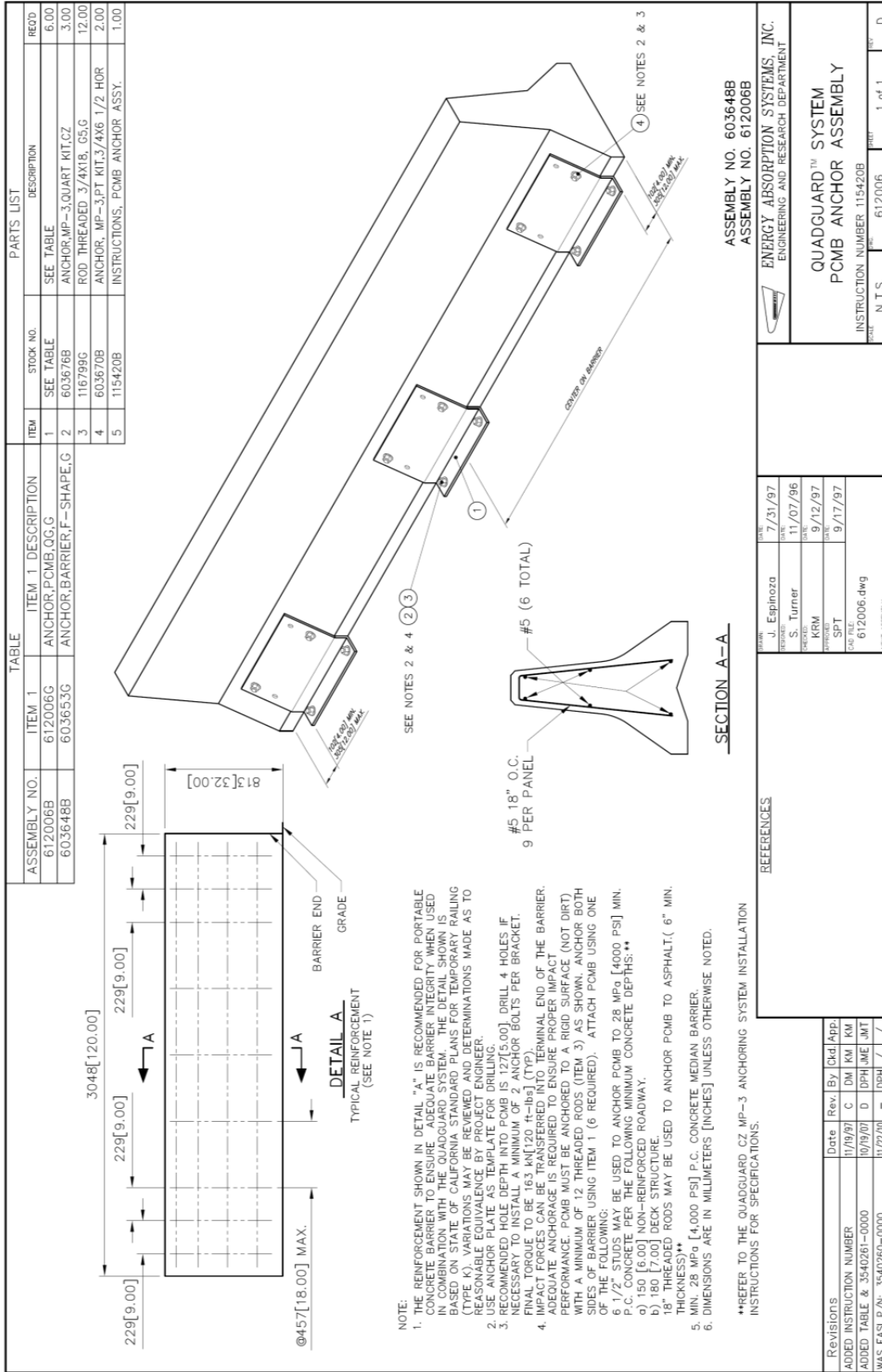

QuadGuard® PCMB Anchor Assembly

NOTE:

- THE REINFORCEMENT SHOWN IN DETAIL "A" IS RECOMMENDED FOR PORTABLE CONCRETE BARRIER TO ENSURE ADEQUATE BARRIER INTEGRITY WHEN USED IN COMBINATION WITH THE QUADGUARD SYSTEM. THE DETAIL SHOWN IS BASED ON STATE OF CALIFORNIA STANDARD PLANS FOR TEMPORARY RAILING (TYPE K). VARIATIONS MAY BE REVIEWED AND DETERMINATIONS MADE AS TO REASONABLE EQUIVALENCE BY PROJECT ENGINEER.
- USE ANCHOR PLATE AS TEMPLATE FOR DRILLING.
- RECOMMENDED HOLE DEPTH INTO PCMB IS 127[5.00]. DRILL 4 HOLES IF NECESSARY TO INSTALL A MINIMUM OF 2 ANCHOR BOLTS PER BRACKET. FINAL TORQUE TO BE 163 KN[120 ft-lbs] (TYP).
- ADDITIONAL ANCHOR BOLTS REQUIRED TO BE INSTALLED AT TERMINAL END OF THE BARRIER. PERFORMANCE PCMB MUST BE ANCHORED TO A RIGID SURFACE (NOT DIRT) WITH A MINIMUM OF 12 THREADED RODS (ITEM 3) AS SHOWN. ANCHOR BOTH SIDES OF BARRIER USING ITEM 1 (6 REQUIRED). ATTACH PCMB USING ONE OF THE FOLLOWING:
 - 1/2" STUDS MAY BE USED TO ANCHOR PCMB TO 28 MPa [4000 PSI] MIN. P.C. CONCRETE PER THE FOLLOWING MINIMUM CONCRETE DEPTHS:
 - 150 [6.00] NON-REINFORCED ROADWAY.
 - 180 [7.00] DECK STRUCTURE.
 - 18" THREADED RODS MAY BE USED TO ANCHOR PCMB TO ASPHALT (6" MIN. THICKNESS)**.
 - MIN. 28 MPa [4,000 PSI] P.C. CONCRETE MEDIAN BARRIER.
- DIMENSIONS ARE IN MILLIMETERS [INCHES] UNLESS OTHERWISE NOTED.

**REFER TO THE QUADGUARD CZ MP-3 ANCHORING SYSTEM INSTALLATION INSTRUCTIONS FOR SPECIFICATIONS.

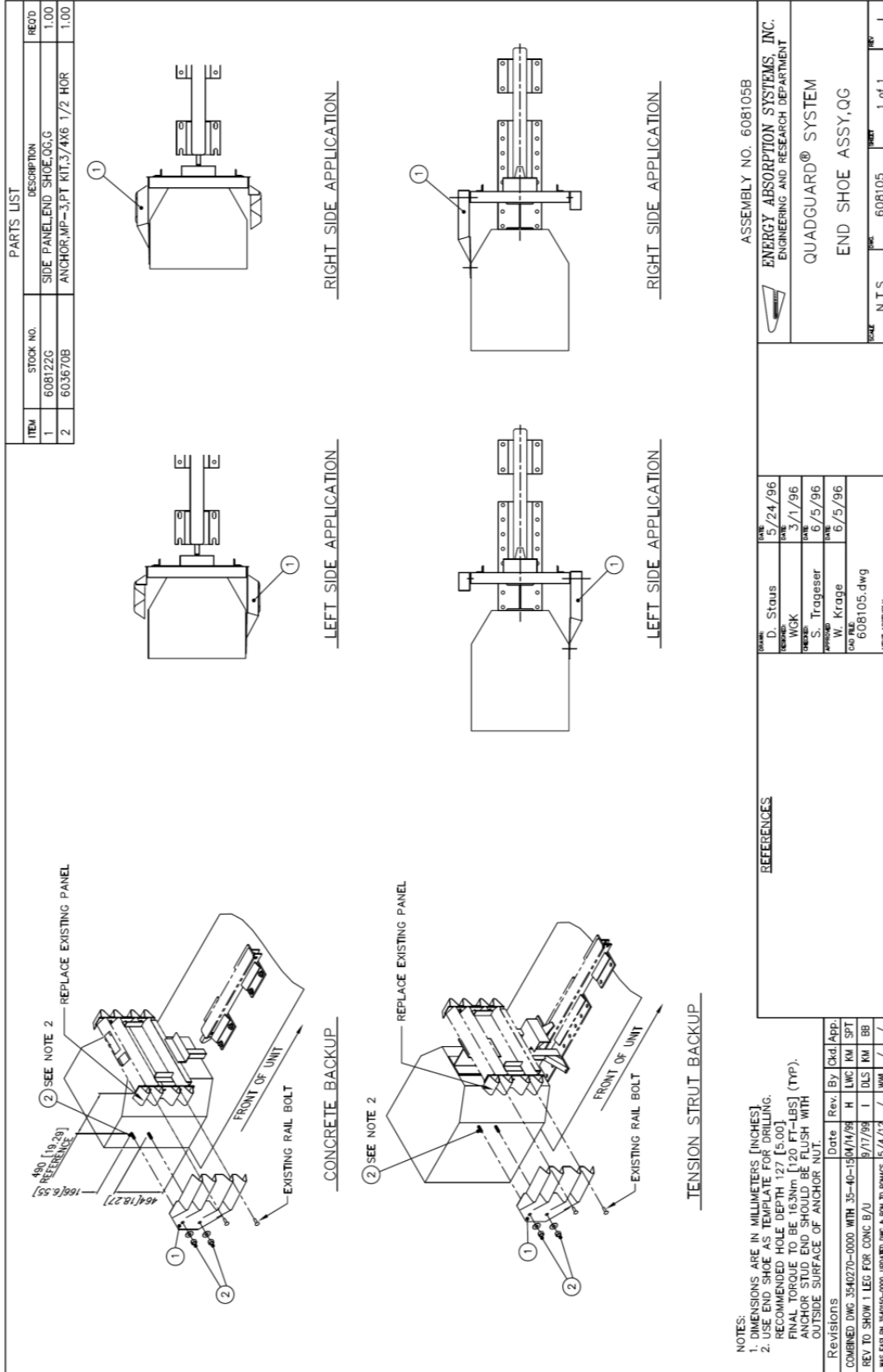

DWG 608105

QuadGuard® End Shoe Assembly

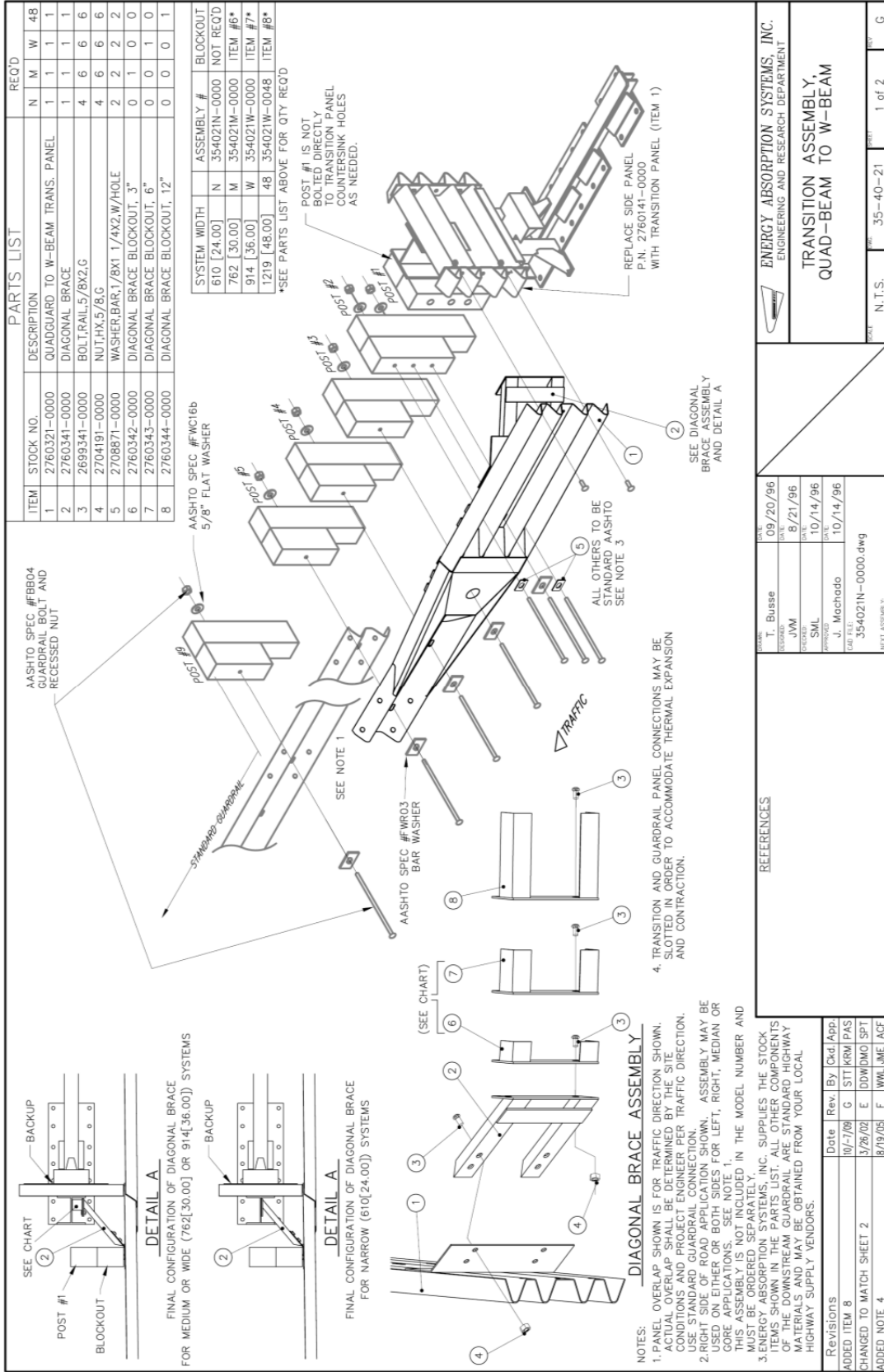

DWG 354021N-0000

QuadGuard® Quad-Beam to W-Beam Transition Assembly

Notes:

Notes:



2525 Stemmons Freeway

Dallas, Texas 75207

888-323-6374 (USA only)

214-589-8140 (Outside USA)

www.energyabsorption.com

www.highwayguardrail.com