

FLORIDA DEPARTMENT OF TRANSPORTATION

BRIDGE LOAD RATING MANUAL, 2016



Chapter 1: Introduction

PURPOSE

This **Manual** provides guidance on bridge load rating in Florida. Load rating analysis approximates safe carrying capacity for bridges, establishes posting restrictions, and estimates strength for permit routing. Such analysis directly supports the Department's Mission, to "... provide a safe transportation system that ensures the mobility of people and goods, enhances economic prosperity and preserves the quality of our environment and communities."

AUTHORITY

Florida Administrative Code 14-15.002, *Manual of Uniform Minimum Standards for Design, Construction, and Maintenance for Streets and Highways* (commonly known as the "Florida Greenbook") requires load rating for all bridges in Florida. This **Manual** establishes "...uniform minimum standards and criteria for the design, construction, maintenance, and operation of public roads..." for bridge load rating, as part of the Departmental powers and duties described by Florida Statutes 334.044.

SCOPE

The principal users of this **Manual** will be all persons involved in bridge load rating in Florida.

DISTRIBUTION

Submit suggestions, and requests for clarification, to the State Load Rating Engineer at CO-LoadRating@dot.state.fl.us. Responses, this **Manual**, and associated materials (archives, references, Excel Load Rating Summary Form, and examples), are available for download at: <http://www.fdot.gov/maintenance/LoadRating.shtm>

PROCEDURE FOR REVISIONS AND UPDATES

Permanent Technical Revisions to this **Manual** are made annually, or “as-needed.” Proposed Revisions are discussed at each Department Load Rating Meeting, held quarterly. Meetings are attended by the District Structures Maintenance Engineers (DSME’s), their designated staff specializing in load rating, and a representative of the State Structures Design Office, who constitute the Load Rating Manual Committee. The Committee builds consensus, and uses the Online Review System to comment on Draft Revisions.

Adoption of a Revision is accomplished by responding to all comments submitted by the Committee, and issuing a Memorandum of Adoption endorsed by the State Structures Maintenance Engineer. The Memorandum outlines revisions, provides rationale, and issues directives for implementation. All Load Rating Revisions to this **Manual** will be published by the Office of Maintenance. The Forms and Procedures Office will update the effective date of the revised **Manual**.

DEFINITIONS AND TERMINOLOGY

Design Load—standard live loading for which the structure was designed or appraised. Design Loads are collections of fictitious trucks and point-and-lane loads, which describe or “envelope” real trucks. A Design Load is assessed at two Rating Levels, Inventory and Operating, defined below.

Load Rating—live load carrying capacity of a bridge.

Load Rating Method, Allowable Stress Rating (ASR)—limits capacity to an allowable stress. Dead loads are unfactored, and live loads are factored with impact. In Florida, ASR load ratings use the HS20 Design Load. ASR follows AASHTO Standard Specifications for Highway Bridges, and MBE Part B.

Load Rating Method, Load Factor Rating (LFR)—uses ultimate strength capacity and factored loading. LFR also incorporates ASR, for some bridge types. In Florida, LFR load ratings use the HS20 Design Load. LFR follows AASHTO Standard Specifications for Highway Bridges, and MBE Part B.

Load Rating Method, Load and Resistance Factor Rating (LRFR)—load rating method similar to LFR, using more complex factors informed by reliability statistics and refined analysis. LRFR uses the HL93 Design Load. LRFR follows AASHTO LRFD Bridge Design Specifications, and MBE Part A.

Rating Level—safety level of the live load capacity for a highway bridge.

Rating Level, Inventory—unlimited application of live loads at this level will not damage the bridge. This is the lowest rating. Permissible stressing is minimized.

Rating Level, Operating—unlimited application of live loads at this level may shorten the life of the bridge. This is the highest rating. Permissible stressing is maximized.

Rating Level, Legal—in Florida, excepting LRFR Steel Service, the Legal Level is equivalent to the Operating Level. Florida has 7 Legal Loads, described in the Appendix to this *Manual*, which envelope the truck configurations permitted by Florida law.

Rating Level, Routine Permit—in Florida, excepting certain LRFR Service tests, the Routine Permit Level is equivalent to the Operating Level. Florida uses the FL120 Routine Permit Vehicle as a reference vehicle, to infer ratings for other permit trucks.

National Bridge Inventory (NBI)—data required to fulfill the National Bridge Inspection Standards. For a description of the NBI data fields, see the FDOT Bridge Management System Coding Guide, referenced below.

Pontis/BrM—bridge data management software.

Rating—rated capacity in tons, equivalent to (Gross vehicle weight)·(Rating Factor).

Rating Factor (RF)—(capacity – dead load) / (live load). Each component of the RF equation is factored.

REFERENCES

Links for the following references are at:

<http://www.fdot.gov/maintenance/LoadRating.shtm>

AASHTO LRFD Bridge Design Specifications (LRFD), 7th Ed. with 15' & 16' Interims.

AASHTO Manual for Bridge Evaluation (MBE), 2nd Ed. with 11' 13' 14' 15' & 16' Interims.

AASHTO Standard Spec. for Highway Bridges (Std.Spec.), 17th Ed. with 2005 Interims.

FDOT Bridge and Other Structures Inspection and Reporting Manual, 2014.

FDOT Bridge Management System Coding Guide (BMS).

FDOT Construction Project Administration Manual (CPAM).

FDOT Plans Preparation Manual (PPM), 2016.

FDOT Standard Specifications for Road and Bridge Construction, 2016.

FDOT Structures Manual Volume 1, Structures Design Guidelines (SDG), 2016.

Manual of Uniform Minimum Standards for Design, Construction and Maintenance for Streets and Highways (GREENBOOK), 2013.

Chapter 2: Load Rating Process and Procedure

CONCEPTS

Utilizing engineering judgment, identify components that may control the load rating, and analyze those components for all applicable limit states and vehicles until the governing member(s) are found. Before confining the analysis to the superstructure, consider the substructure. For example rotted timber piles, settlement, excessive scour, or distressed pile caps would all warrant additional consideration.

Accurate load ratings are essential to permit routing. Operating and FL120 results are used to route permit overloads on State highways in Florida. Overloads include blanket permits, like cranes, and special trip permits, such as bridge girder deliveries.

Use an appropriate level of analysis to establish a safe load carrying capacity that does not unduly restrict legal and permit traffic. Begin with a simplified level of analysis. Refine the analysis as necessary to provide a more accurate load rating. “As necessary” means:

1. Appropriately consider posting avoidance.
2. Apply additional scrutiny to results that markedly differ from the Design Load.
3. Apply refinements to results that obviously mischaracterize the safe carrying capacity of the bridge.

Adopt one method of analysis, and do not report a mixed-method summary. For example, if the HL93 Inventory rating uses refined distribution, then the HL93 Operating and FL120 Permit ratings also require refined distribution. Be consistent. The governing methodology and distribution shall apply to the entire structure. While the contents of an analysis may explore several methods, clearly and consistently state which method was ultimately adopted, and which results govern.

DEFINITION, COMPLETE LOAD RATING

A complete load rating is a high-quality PDF report, wherein any scans are 300dpi+ and 75%+ quality compression. Seal digital deliveries unlocked; this retains the original document ("view sealed version"), but permits subsequent comments. Contents include:

1. **SUMMARY.** Load rating summary form (Excel), sealed by a Florida P.E.
2. **NARRATIVE.** Brief description of inspection findings, methodology, and assumptions.
3. **PLANS.** Plan sheets required to perform the analysis (not the entire plan set).
4. **CALCULATIONS.** Inputs, intermediate calculations, and summarized outputs.
5. **QUICK CHECK.** At a minimum, confirmation of the governing Design Operating Rating; show the factored components of the rating factor equation. A more comprehensive check is recommended, especially when results significantly differ from the original Design Load increased to the Operating Level.

Additionally, submit all inputs in native ready-to-run format. Exceptions include hand calculations, and proprietary worksheets that are sufficiently transparent.

DEFINITION, AS-BUILT LOAD RATING

Typically, an As-Built Load Rating confirms that the Design Load Rating (As-Bid Load Rating) remains valid, and a sealed summary form indicating it is reflective of the As-Built conditions will suffice. However, if the Engineer of Record (EOR) finds that the As-Built condition substantively differs from Design, then an As-Built load rating constitutes a complete revision of the Design Load Rating.

DEFINITION, AS-BUILT DOCUMENTS PACKAGE

The As-Built Structure Documents Package contains select bridge records that the District Structures Maintenance Office (DSMO) is required to store for the life of the bridge (MBE Section 2). For FDOT projects, follow the CPAM. For other projects, the package is a ZIP archive containing one bridge; PDF contents are either direct-to-pdf, or scanned at 300dpi+ and 75%+ quality compression. The package contains:

1. Foundation records: pile driving records, shaft tip elevations, and boring logs.
2. Structure plans: shop drawings, and As-Built plans (alternatively sealed design plans, with a summary of construction changes).
3. For bridges traversing water, a sealed Hydraulic analysis plan sheet.
4. Sealed As-Built load rating.

TABLE 2-1—EXISTING BRIDGES

PHASE	ACTION
NBI Inspection	<p>In Pontis/BrM Inspection Notes, state whether the current load rating is complete and applicable. The note should indicate who made the determination, and when.</p> <p>“Complete” means that the rating complies with the rules¹ that were in effect when the rating was performed. Historic ratings shall, at a minimum, include a summary and calculations. “Applicable” means that the configuration and condition of the bridge has not substantially changed, since the calculations were performed.</p> <p>If the analysis is incomplete or inapplicable, notify the DSME and begin revisions.</p>
Load Rating Revision	<p>Within 90 days of the date that the NBI Inspection Report was sealed, or earlier as the DSME determines for emergencies, (1) Revisions are to be completed and input into Pontis/BrM, and (2) If the analysis recommends posting for weight, a notification shall be sent to the bridge Owner. For load rating revisions, follow FDOT Figure 2-1.</p>
Posting	<p>Posting deficiencies shall be addressed within 30 days of receipt of notification to the bridge Owner; see Chapter 7 of this <i>Manual</i>.</p>

1. From time-to-time, interim revisions are required. For example, all structures with transverse floorbeams are required to report transverse data.

TABLE 2-2—WIDENINGS, REHABILITATIONS, AND NEW BRIDGES

PHASE	ACTION	RESPONSE, LOAD RATING SPECIALIST
90% Superstructure Plans	EOR – Submit ¹ Draft Load Rating	Within 30 days, review and return comments to the designer or analyst.
Final Plans (Design-Bid-Build), or Released for Construction (Design-Build)	EOR – Submit ¹ sealed Design Load Rating	Within 14 days: <ul style="list-style-type: none"> • Confirm that review comments were addressed, and respond with a receipt to the EOR. If the rating is acceptable, archive it to EDMS. Otherwise request revisions. • Determine whether the new load rating applies. At a strengthening project, for example, the new rating will not apply until that strengthening has occurred. • Document the determination in Pontis/BrM Structures Notes, and accordingly update or retain the Pontis/BrM load rating data.
Superstructure Nearing Completion	CEI – Submit ¹ the As-Built Documents Package	Determine whether the As-Built Documents Package is complete. If so, confirm the schedule for the final inspection. Otherwise, specify insufficiencies within the As-Built Documents Package, schedule a safety inspection, and establish a timeline for completion.
Superstructure Complete	LEAD BRIDGE INSPECTOR – Submit ¹ draft inspection	When the initial NBI inspection occurs, or before, apply the As-Built load rating to Pontis/BrM, and archive the data to EDMS. If a load rating is not available, the Engineer responsible for the inspection will use engineering judgment, assign a sealed temporary load rating, and notify the State Load Rating Engineer; complete an analysis and input the results within 90 days of the date that the NBI report was sealed.

1. Submit deliverables to DX-LoadRating@dot.state.fl.us, where “X” is the District No. For example, District 1 is *D1-LoadRating@dot.state.fl*.

For widenings and rehabilitations, follow FDOT Figure 2-2, and FDOT Structures Design Guidelines, Chapter 7. For new bridges, provide Strength for the FL120 ($RF_{FL120} \geq 1.00$), and comply with FDOT Structures Design Guidelines. New (non-widening) precast culvert projects must provide a load rating, or contract language that requires the Contractor to provide a load rating in accordance with this **Manual**.

FDOT Figure 2-1— Existing Bridges

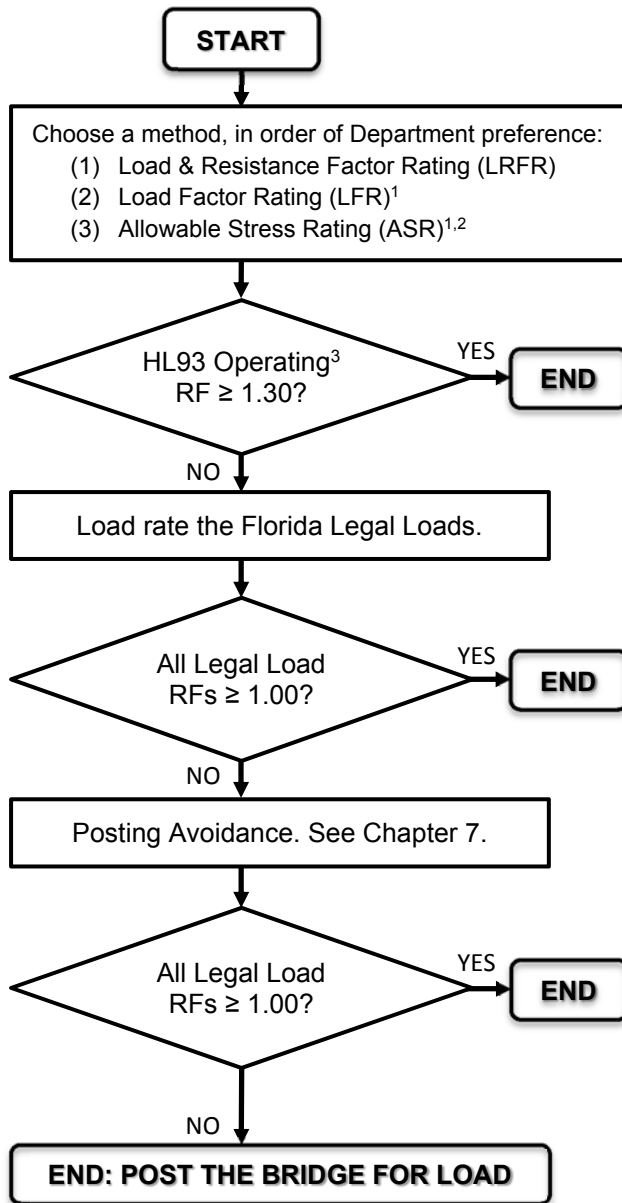

FDOT Fig.2-2—Widening & Rehab.

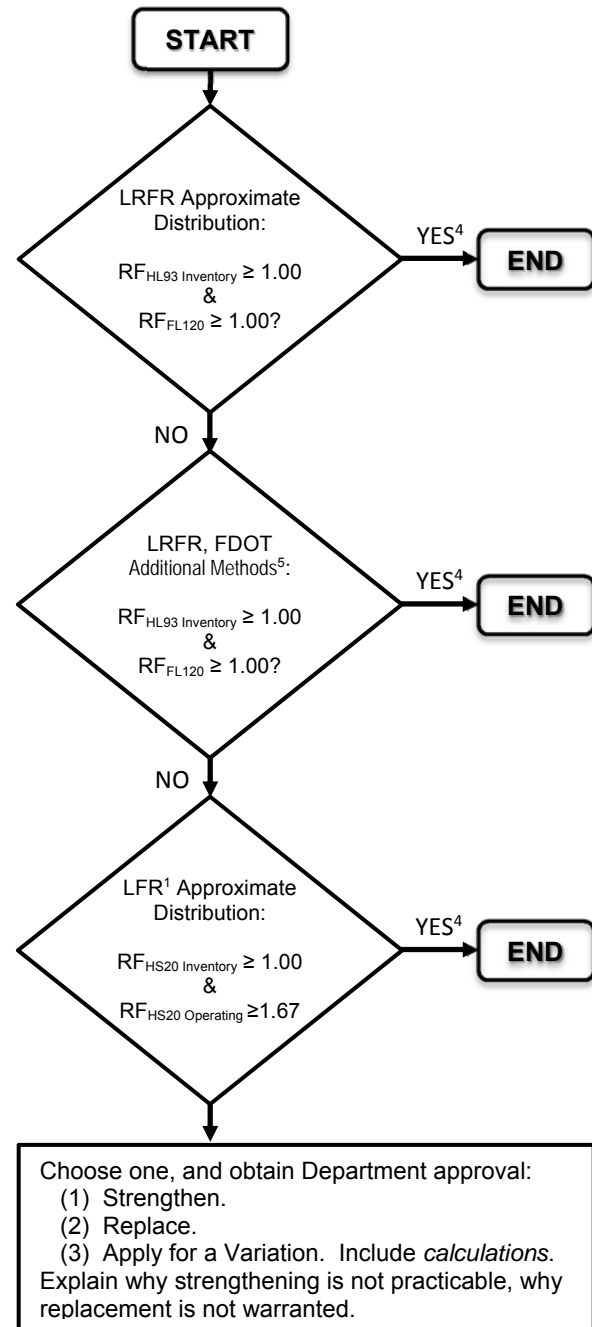

1. LFR and ASR are not permitted among spans exceeding 200 feet.
2. ASR is not permitted for bridges on the National Highway System.
3. At existing bridges, if $RF_{HL93 \text{ Operating}} < 1.30$, or if LFR/ASR, assess the Legal Loads.
4. Widening and rehabilitations need not assess the Florida Legal Loads; the HL93, FL120, and HS20 Rating Factor requirements are sufficient.
5. FDOT Additional Methods can be found at SDG 7.1.1 C.

COMMENTARY, DX-LOADRATING EMAIL

The delivery email DX-LoadRating@dot.state.fl.us, where “X” is the District Number, reliably specifies the address of the reviewer and end-user of the documents that this chapter requires. Submissions may also be accomplished by alternative means established by contract documents, provided that the delivery mechanism is effective and efficient. For example, the CPAM process of notifying the DSME is also acceptable.

CITATIONS, EXTERNAL MANUALS

Load rating involves Design, Construction, and Maintenance. Participants include State, Toll, and Local authorities. To accommodate a variety of participants, and to develop a coherent and practicable load rating policy and process, this **Manual** draws from other manuals.

SDG. Structures Design Guidelines (SDG), from 2016 FDOT Structures Manual Volume 1, governs all Department structures design, and informs all bridge structures design in Florida. At 90% plans, perform a load rating (1.7). For bridge-size culverts, see 3.15.14. For bascule bridges, see 8.1.1. Widen and rehabilitate bridges in accordance with Chapter 7. This **Manual** adopts the SDG, and the SDG refers to this **Manual** for load rating. However note these differences:

1. In addition to the standard Load Rating Summary Form (Excel), the Design of new bridges and widenings also requires a Load Rating Plan Sheet. See: <http://www.fdot.gov/structures/CADD/standards/CurrentStandards/LRFRsummaryTables.pdf>
2. The design of bascule bridges requires an unpinned span lock assumption, as a part of the load rating analysis. For the appraisal of existing bascule bridges, this **Manual** defers to the local District Structures Maintenance Engineer for specific instructions.

GREENBOOK. Locally-owned bridges conform to the May 2013 Edition of The Manual of Uniform Minimum Standard for Design, Construction and Maintenance for Streets and Highways (commonly referred to as the Florida “Greenbook”). Design per LRFD (Ch.17 C). Perform a hydraulic analysis (Ch.17 C.4a). Provide certain As-Built structure documents (Ch.17 D). For load rating, refer to this **Manual** (Ch.17 G). Note that the timelines for submission have been advanced (this **Manual**), that the timeline for load posting has been advanced to 30 days (this **Manual**, and Florida Statute 335.074(5)).

PPM. All State-owned bridges, and many others, abide by the FDOT Plans Preparation Manual (PPM). For Design Variations permitting deficient strength, seek a recommendation from the Office of Maintenance, and approval from the State Structures Design Engineer, by providing calculations and a “Detailed explanation of why the criteria or standard cannot be complied with or is not applicable” (Ch. 23). For load rating, refer to this **Manual** (23.17). At the 90% plans phase, submit a draft load rating; at final plans, submit a sealed load rating (26.17 and Exhibit 26-D).

CPAM. The FDOT Construction Project Administration Manual (CPAM) specifies procedures for the construction of State projects. Non-State projects may also utilize the CPAM, or concepts within the CPAM. For major changes, revise the load rating (5.12.6). Submit As-Built bridge documents (5.12.7, 6.2.9.9, and 6.2.9.10). Submit an As-Built load rating (10.11.4). Archive certain As-Built documents to Construction Documents Management System (CDMS), and attribute those documents with the Structure Number (10.11.5). Incidentally, the maximum retention time for CDMS documents is 15 years; Structures Maintenance reviews and archives As-Built documents more durably, for 99 years.

Chapter 3: Responsibilities

DISTRICT STRUCTURES MAINTENANCE OFFICE

1. Ensure that every bridge within the jurisdiction of the District is properly load rated, timely updated, and accurately reported to the Bridge Management Database, in accordance with this **Manual**.
2. Perform and review load ratings. Review all new load ratings cursorily, and at least 10% of new load ratings thoroughly, with separate and unique review calculations for the governing elements.
3. Review NBI inspections, and determine whether the present load rating remains complete and applicable.
4. Administer and verify bridge load posting with the District Local Bridge Coordinator.
5. Provide information to the Overweight/Over-Dimensional Permit Office to facilitate safe routing.
6. Assist the Office of Maintenance, other branches of the Department, and local authorities.
7. Write and maintain a Quality Control (QC) Plan that explains how these tasks are accomplished. The QC Plan need not reiterate the contents of this **Manual**; instead, the QC Plan should emphasize day-to-day tracking and documentation.

DISTRICT MAINTENANCE ENGINEER

Designate staff to inform the Overweight/Over-Dimensional Permit Office of temporary clearance restrictions due to construction activity. Additionally, advise upon the best time to move permitted cargo, with respect to special events and local traffic conditions.

OFFICE OF MAINTENANCE

1. Annually perform a Quality Assurance Review (QAR) of the load rating performance of each District. The current schedule, monitoring plans, critical requirements and compliance indicators are included in the Quality Assurance Plan available at the internal Office of Maintenance SharePoint site:
<http://cosharepoint.dot.state.fl.us/sites/maintenance/>
2. Assist Districts, other branches of the Department, and local authorities.
3. Maintain this **Manual**.
4. Resolve inconsistencies arising from FDOT guidance.
5. Provide training, share new procedures, and respond to questions.

6. Provide load rating examples.
7. Review load posting requests for State-maintained bridges.
8. Provide courtesy reviews, for Districts and local agencies.
9. Perform evaluations and load ratings for State-owned bridges to improve commercial truck mobility.

STATE STRUCTURES DESIGN OFFICE

1. Review this *Manual*.
2. Review new and proposed design methods.
3. Assist the Office of Maintenance with load testing and complex analysis.

CONSULTANTS

1. Assist the Department in accordance with contract documents.
2. Perform and review load ratings in accordance with this *Manual*.
3. Write and maintain a Quality Control (QC) Plan that explains how load rating reviews are performed and documented. Within the QC Plan, include a Quality Assurance Review (QAR) component, which investigates and reports upon the quality of the work product, annually or more frequently. The QC plan will state where the QAR records are kept.

CHAPTER SEQUENCE

This *Manual* retains a legacy numbering sequence; chapter numbers 4 and 5 are omitted.

Chapter 4

This Chapter is reserved for future use. MBE Section 4—Inspection is unmodified.

Chapter 5

This Chapter is reserved for future use. MBE Section 5—Materials is unmodified.

Chapter 6: Load Rating Analysis

Chapter 6 of this *Manual* modifies the current AASHTO Manual for Bridge Evaluation (MBE). The MBE governs on all relevant topics not directly addressed in this *Manual*.

6.1—SCOPE

Remove: “No preference is placed on any rating method. Any of these three methods identified above may be used to establish live load capacities and load limits for the purposes of load posting.”

Add: “The load rating of all bridges shall be in accordance with Chapter 2 of this *Manual*. The Department prefers LRFR.”

C6.1

Add: For segmental bridges, since ASR and LFR are inadequate, use LRFR. For spans exceeding 200 feet, since MBE Part B legal loading is excessive, use LRFR.

Regarding ASR, in 1993 the FHWA requested that all ASR ratings on the National Highway System (NHS) be rerated with LFR. FDOT and FHWA agreed that only structurally deficient or functionally obsolete NHS ratings required re-rating. These, and all subsequent revisions to NHS ratings, shall use either LFR or LRFR.

6.1.4—Bridges with Unknown Structural Components

Replace subsection with: For bridges that lack plans, perform field measurements. At a minimum, the field kit should include a tape, a caliper, and a pachometer. Use plans from a similar bridge or era-appropriate code to conservatively approximate the reinforcement, and analyze the bridge. If the reinforcement cannot be estimated, and the bridge shows no distress, an assigned load rating is acceptable. Otherwise perform additional non-destructive testing as necessary, and analyze or proof-test the bridge.

Chapter 6 Part A: Load and Resistance Factor Rating

6A.1.5—Load and Resistance Factor Rating

Remove: “A detailed rating flow chart is included in Appendix A6A.”

Add: The routine FDOT rating process is described in Chapter 2 of this **Manual**.

6A.1.5.2—Legal Load Rating

Remove: “Live load factors are selected based on the truck traffic conditions at the site.”

Add: Legal live load factors are consistently applied for all traffic conditions.

6A.1.5.3—Permit Load Rating

Remove: “Calibrated load factors by permit type and traffic conditions at the site are specified for checking the load effects induced by the passage of the overweight truck.”

Add: FL120 Routine Permit live load factors are consistently applied for all traffic conditions. Special Permits shall follow the MBE requirements, unless otherwise specified in writing by the Office of Maintenance.

6A.2—LOADS FOR EVALUATION

6A.2.3.1—Vehicular Live Loads (Gravity Loads): LL

Replace subsection with: Live load models include: (1) HL93 Design Load, (2) Florida Legal Loads, and (3) FL120 Routine Permit. For Design, Legal, and Routine Permits, apply consistent live load factors for all traffic conditions, as specified in FDOT Table 6A.4.2.2-1. For Special Permits, use the Actual Permit Truck, and live load factors as specified by the MBE.

6A.3.2—Approximate Methods of Structural Analysis

Add: Extend the range of applicability for approximate distribution as described at SDG 2.9. Also, if concrete parapets or barriers are continuous near midspan (without open joints), neglect the exterior beam rigid section assumption at LRFD C4.6.2.2.2d-1.

C6A.3.2

Add: Continuous parapets and barriers stiffen the exterior section. While parapets and barriers are susceptible to vehicular impacts, the same is true for beams (over-height vehicular impacts). Load testing has shown that, while the parapet-beam stiffness does attract load, the stresses are lower than the rigid section assumption surmises. The modification only applies to continuous parapets; the rigid section assumption may apply to bridges with parapets containing open joints near midspan.

6A.3.3—Refined Methods of Analysis

Add: Refined methods include two or three dimensional models using grid or finite-element analysis. Excepting parapet self-weight, and posting avoidance, refined analyses may not benefit from edge stiffening effects from barriers or other appurtenances. On the load rating summary form, state the name and the version of the software that was used. Within the load rating narrative, explain why refined analysis was used.

6A.4—LOAD RATING PROCEDURES

6A.4.1—Introduction

Replace subsection with: Use 6A.4.2—General Load-Rating Equation with FDOT Table 6A.4.2.2-1—LRFR Limit States and Load Factors. Evaluate FL120 Permit, HL93 Inventory, and HL93 Operating. For existing bridges, if the HL93 Operating Rating Factor is less than 1.30, then additionally evaluate the Florida Legal Loads.

6A.4.2—General Load Rating Equation

6A.4.2.1—General

Add:

$RATING = RF \cdot GVW = \text{Permissible weight in tons}$

RF = Rating factor

GVW = Gross vehicle weight (axle loading of the heaviest truck that the vehicle considers)

For example, the rating for the HL93 is (36 tons)·(HL93 Rating Factor), irrespective of whether the tandem or another combination governs. Likewise, for a long-span bridge, the rating for an SU4 is (35 tons)·(SU4 Rating Factor), even if the lane-and-truck combination governs.

C6A.4.2.1

Add: While permit routing uses rating factors, the Bridge Management System retains ratings in terms of tons. The $RATING = RF \cdot GVW$ standard forms a reliable way to reconstruct rating factors, from ratings in tons.

6A.4.2.2—Limit States

Replace Table 6A.4.2.2-1 with:

FDOT Table 6A.4.2.2-1—LRFR Limit States and Load Factors

Bridge Type	Limit	DC ⁷	LL Inventory	LL Operating	LL Legal	LL FL120
Steel ³	Strength ¹	1.25/0.90	1.75	1.35	1.35	1.35
	Service ² II	1.00	1.30	1.00	1.30	0.90
Reinforced Concrete ⁴	Strength ¹	1.25/0.90	1.75	1.35	1.35	1.35
	Service ² I	NA	NA	NA	NA	NA
Prestressed Concrete ⁵	Strength ¹	1.25/0.90	1.75	1.35	1.35	1.35
	Service ² III	1.00	0.80	NA, 0.80 ⁵	NA, 0.80 ⁵	NA, 0.70 ⁵
Post Tension I-Girder ⁶	Strength ¹	1.25/0.90	1.75	1.35	1.35	1.35
	Service ² III	1.00	0.80	0.80	0.80	0.70
Timber	Strength ¹	1.25/0.90	1.75	1.35	1.35	1.35
	Service ²	NA	NA	NA	NA	NA

1. "Strength" includes flexure, shear, and compression. Typically appraise both flexure and shear. Determine whether compression and axial effects need be assessed, also.
2. "Service" means the allowable tension limit for the beam material.
3. Steel Service II need only be checked for compact girders.
4. For segmental box girder decks, see FDOT 6A.5.11. For reinforced concrete box culverts, see 6A.5.12.
5. Prestressed girders in good condition shall only apply Service III to the Inventory Level; assess Operating Legal and Permit Levels with Strength. However, for prestressed girders exhibiting distress or corrosion:
 - include Service III for the Operating Legal and Permit Levels
 - limit stresses to FDOT Table 6A.5.4
 - use the Service III live load factors in the table above.
6. For segmental post-tension box girders, see 6A.5.11.
7. Field-measure wearing surfaces; $\gamma_{DC} = \gamma_{DW}$.

6A.4.2.4 System Factor, ϕ_s

Add: System factors, in FDOT Tables 6A.4.2.4-1 (General), 6A.4.2.4-2 (Steel), and 6A.5.11.6-1 (Post-Tension), shall apply for flexural and axial effects at the Strength Limit States. Higher values than those tabulated may be considered on a case-by-case basis with the approval of the Department. System factors shall not be less than 0.85, nor greater than 1.3.

Replace Table 6A.4.2.4-1 with:

FDOT Table 6A.4.2.4-1—General System Factors (ϕ_s)

Superstructure Type	ϕ_s
Rolled/Welded Members in Two-Girder/Truss/Arch Bridges ¹	0.85
Riveted Members in Two-Girder/Truss/Arch Bridges	0.90
Multiple Eyebar Members in Truss Bridges	0.90
Floor beam spacing > 12 feet, discontinuous deck	0.85
Floor beam spacing >12 feet, continuous deck	0.90
Redundant Stringer subsystems between Floor beams	1.00
All beams in non-spliced concrete girder bridges	1.00
Steel Straddle Bents	0.85

Add: **FDOT Table 6A.4.2.4-2—System Factors (ϕ_s) for Steel Girder Bridges**

No. Girder Webs	ϕ_s With Diaphragms ¹	ϕ_s Without Diaphragms
2	0.90	0.85
3	1.00	0.90
4 or more	1.00	1.00

1. “With Diaphragms” means that there are at least three evenly spaced intermediate diaphragms (excluding end diaphragms) in each span. The above tabulated values may be increased by 0.05 for riveted members.

6A.4.4—Legal Load Rating

Replace subsection with: When $RF_{HL93.Operating} < 1.30$, analyze the Florida Legal Loads with the applicable limit states and load factors provided in FDOT Table 6A.4.2.2-1. Legal loads are described in the Appendix to this **Manual**. Apply the same Florida Legal Loads to each loaded lane; do not mix trucks. Excepting box culverts and segmental bridges, use multiple presence factors per LRFD 3.6.1.1.2.

C6A.4.4—Legal Load Rating (*add this subsection*)

Districts may request that the legal loads be assessed irrespective of the HL93 Operating rating. Florida applies uniform live load factors, for all Average Daily Truck Traffic. Florida legal vehicles envelope all SHVs, excepting the SU7, which is not permitted by Florida law.

6A.4.5—Permit Load Rating

Add: For the FL120, only use the insertion 6A.4.5.A below, and its references. For special single-trip permits, perform the analysis in accordance with MBE requirements, unless otherwise specified in writing by the Office of Maintenance.

6A.4.5.A—FL120 Permit (*add this subsection*)

For all LRFR analyses, assess the FL120 with the applicable limit states and load factors provided in FDOT Table 6A.4.2.2-1. The FL120 is depicted in the Appendix to this **Manual**. The FL120 is present in all loaded lanes; do not mix the FL120 with other truck types. Excepting new box culverts, use a multiple presence factor of 1.00 for single-lane FL120 distribution, and multiple presence factors per LRFD 3.6.1.1.2 for multi-lane FL120 distribution.

C6A.4.5.4.1

Add: The FL120 permit load is conceived to be a benchmark to past HS20 Load Factor Design (LFD). LFD Strength live load factors were $\gamma_{Inventory} = 2.17$ and $\gamma_{Operating} = 1.30$. Since $\gamma_{Inventory}/\gamma_{Operating} = 1.67$, if $RF_{HS20.LDF.Inventory} > 1.00$, then $RF_{HS20.LDF.Operating} > 1.67$ and $RATING_{HS20.LDF.Operating} > 60$ tons. Hence, the FL120 truck is $1.67 \cdot HS20$ truck, or 60 tons.

6A.5—CONCRETE STRUCTURES

Add: When assessing prestress condition among corroded or cracked beams, recommended reading includes:

1. Naito, Clay et al. “Forensic Examination of a Noncomposite Adjacent Precast Prestressed Concrete Box Beam Bridge.” *Journal of Bridge Engineering* July/August 2010, Figure 13.
2. Hartle, Raymond. “I-70 Overpass Beam Failure at Lakeview Drive Bridge.” https://www.nhi.fhwa.dot.gov/downloads/other/real_solutions_presentations/real_solutions_presentation_2008_07.pdf, slide 22.

Replace Table 6A.5.2.1-1 with:

FDOT Table 6A.5.2.1-1—Minimum Strength of Concrete by Year of Construction

Year of Constructor	Compressive Strength, f_c (ksi)
Before 1959	3.0 - Reinforced Concrete
1959 to 1973	3.0 - Reinforced Concrete 5.0 - Prestressed Beam
After 1973	3.4 - Reinforced Concrete 5.0 - Prestressed Beam

Replace Table 6A.5.2.2-1 with:

FDOT Table 6A.5.2.2-1—Yield Strength of Reinforcing Steel

Reinforcing Type	Yield, f_y (ksi)
Unknown, constructed prior to 1954	33
Structural grade	36
Unknown, constructed between 1954 and 1972: billet or intermediate grade	40
Rail or hard grade	50
Unknown, constructed after 1972	60

6A.5.2.3—1 Prestressing Steel

Add: For prestressing losses, use LRFD 5.9.5.3—Approximate Estimate of Time-Dependent Losses.

6A.5.4—Limit States

Replace “Table 6A.4.2.2-1” with FDOT Table 6A.4.2.2-1.

Add: FDOT Table 6A.5.4—Stress Limits for Concrete Bridges

Condition	Design Inventory	Operating & Permit
Compressive Stress – All Bridges (Longitudinal or Transverse) Compressive stress under effective prestress, permanent loads, and transient loads. When web or flange slenderness exceeds 15, apply a reduction (LRFD 5.9.4.2.1 and 5.7.4.7.2).		
All environments	0.60f _c	0.60f _c
Longitudinal Tensile Stress, Non-Segmental		
Extremely aggressive corrosion environment	3√f _c psi	7.5√f _c psi
Slightly or moderately aggressive corrosion environments	6√f _c psi	7.5√f _c psi
Components with unbonded prestressing tendons	no tension	no tension

Add: For prestressed beams in good condition, do not apply Service III to the Operating and Permit Levels; see notes at FDOT Table 6A.4.2.2-1. For segmental post-tension bridges, see stress limits at FDOT Tables 6A.5.11-1 & 6A.5.11-2.

6A.5.4.2.2a—Legal Load Rating

Remove subsection (for Service III, see FDOT Table 6A.4.2.2-1).

6A.5.4.2.2b—Permit Load Rating

Replace subsection with: “For special single-trip permit loads having Flexure Strength load factors less than 1.30, consider a lower tendon limit at 90% yield. Otherwise neglect this check.”

C6A.5.4.2.2b

Add: When the 90% yield lower tendon limit is rigorously analyzed under typical load factors, it does not meaningfully govern. Since the check is not helpful, difficult to properly execute, and confused with other flavors of “Service I,” it is no longer specified for normal load rating.

6A.5.7—Evaluation for Flexural and Axial Force Effects

Add: Flat slab longitudinal edge beams (LRFD 4.6.2.1.4b) and exterior flat slab beams (types “f” and “g” in LRFD Tables 4.6.2.2.2d-1 and 4.6.2.2.3b-1) may be neglected, provided:

1. Curbs or barriers are present, concrete, and continuous (no open joints).
2. The exterior strength per foot meets or exceeds the interior strength per foot.

C6A.5.7

Add: See C6A.3.2.

6A.5.8—Evaluation for Shear

Replace subsection with: When using Modified Compression Field Theory (MCFT) at LRFD 5.8.3.4.2—General Procedure, (1) Follow MBE Figure 6A.5.8-1, and count the stirrup area intersected by the failure plane $0.5 \cdot d_v \cdot \cot(\theta)$ on each side of the section under consideration, (2) Apply the appropriate load factor. An HL93 Operating rating, for example, would use $\gamma_{LL, Strength, I, Operating} = 1.35$ in its capacity calculations. See “Prestressed concrete shear capacity is load-dependent,” at MBE Example A3, page A-115.

For prestressed members governed by shear, where $RF_{LRFR, FL120} < 1.00$ or $RF_{LRFR, HS20} < 1.67$, use LRFD 5.8.3.4.2—General Procedure with refined distribution, or LRFD 5.8.3.4.3—Simplified Procedure with approximate distribution. Alternatively, narrate why those procedures should not apply to the bridge or element under consideration (excessive debonding under the web at the governing location, relevant research or load testing, girder condition, etc.).

Reinforced and prestressed slab-type bridges may omit the shear check, provided good condition near the bearing areas. Other concrete bridge types will include a shear check for all vehicles and rating levels assessed.

C6A.5.8

Add: Shear cracking has occurred among beams that were heavily debonded under the web. Scrutinize original plans for this defect; where it is found, consider strengthening. Additionally, for shear, an independent check of the governing section is recommended.

6A.5.10—Temperature, Creep, and Shrinkage Effects

Add: For segmental post-tension elements, apply FDOT Tables 6A.5.11-1 & 6A.5.11-2.

6A.5.11—Rating of Segmental Concrete Bridges

Add: The evaluation of segmental post-tension structures is unusually complex. Before performing load rating analysis, as part of the scope development, peruse bridge inspection reports, gather As-Built data, and review this section. Identify any local details (i.e. diaphragms, anchorage zones, blisters, deviation saddles, etc.) exhibiting distress, and add their evaluation to the scope. For expanded guidance on segmental post-tension bridge evaluation, see:

<http://www.fdot.gov/structures/posttensioning/NewDirectionsPostTensioningVol10A.pdf>

6A.5.11.2—General Rating Requirements

Add: Apply FDOT Tables 6A.5.11-1, 6A.5.11-2, and 6A.5.11.6-1. Load rate HL93-Inventory, HL93-Operating, and FL120-Permit, for all six tests in FDOT Table 6A.5.11-1. For limit states where $RF_{HL93Operating} < 1.30$, also load rate the Florida Legal Loads; confine Legal Load assessments to marginal limit states where $RF_{HL93Operating} < 1.30$.

Use MBE Equation 6A.4.2.1-1 as expanded below, to determine the rating factor. The variance of sign, \pm , is implicit for all variables.

$$RF = \frac{C - [\gamma_{DC} \cdot DC + \gamma_{DW} \cdot DW + \gamma_{EL} \cdot EL + \gamma_{FR} \cdot FR + \gamma_{CR} \cdot (TU + CR + SH)]}{\gamma_{LL} \cdot (LL + IM)}$$

RF	Rating factor
C	Factored capacity.
γ	Load factor
DC	Component dead load
DW	Wearing dead load
EL	Permanent locked-in erection forces
FR	Bearing friction, or frame action
TU	Uniform temperature
CR	Creep
SH	Shrinkage
LL	Live load
IM	Dynamic impact

Add: FDOT Table 6A.5.11-1—LRFR Load Factors, Segmental Post-Tension Bridges

Direction & Limit		Factored Capacity C	LL Operating, Design Legal, and FL120 OPR¹ FL120¹
Longitudinal	Strength, Flexure	$\psi_c \cdot \psi_s \cdot \psi \cdot R_n$	1.35
	Strength, Shear	$\psi_c \cdot \psi \cdot R_n$	1.35
	Service III, flanges	FDOT Table 6A.5.11-2	0.90 SL ²
	Service III, web	$3 \cdot v_{fc} \cdot \text{psi}$	0.90 SL ²
Transverse ³	Strength, Flexure	$\psi_c \cdot \psi \cdot R_n$	1.35
	Service I	$f_{r,inv} = 3 \cdot v_{fc} \cdot \text{psi}$ $f_{r,opr} = 6 \cdot v_{fc} \cdot \text{psi}$	1.00

1. Apply the multiple presence factor (mpf) to all loaded lanes, per LRFD 3.6.1.1.2, except make the single-lane mpf 1.00, for Operating and FL120 Permit Levels.
2. “SL” means the number of striped lanes; consider $1 \leq \text{lanes loaded} \leq \text{SL}$.
3. For transverse limits, omit the lane load; neglect the 0.64klf HL93 lane load, and do not consider the 0.20klf legal and FL120 lane loads.

Add: FDOT Table 6A.5.11-2—Longitudinal Stress Limits, Segmental Post-Tension

Joint Type and Environment	Inventory	Operating & FL120 Permit
Sufficiently-reinforced ¹ , moderately aggressive corrosion environment	$6\sqrt{f_c}$ psi	$6\sqrt{f_c}$ psi
Sufficiently-reinforced ¹ , extremely aggressive corrosion environment	$3\sqrt{f_c}$ psi	$3\sqrt{f_c}$ psi
Insufficiently-reinforced, all environments	No Tension	No Tension ²
Dry Joints with no epoxy, all environments	100 psi min. compression	No Tension

1. Sufficiently-reinforced joints are cast-in-place closure pours, with bonded longitudinal auxiliary reinforcement sufficient to carry the calculated longitudinal tensile force at a stress of $0.50 \cdot f_{yield}$, under an uncracked assumption.
2. With Departmental approval, insufficiently-reinforced joints justified to be in good condition (i.e. no leaks and fully sealed) may escalate the allowable Operating & FL120 Permit stress to 200 psi tension.

6A.5.11.4—Design-Load Rating

Add: The capacity of a section is determined by using any of the relevant formulae or methods in the LRFD Specifications, including more rigorous analysis techniques involving strain compatibility. When capacity depends upon a combination of both internal (bonded) and external (unbonded) tendons, use a more rigorous technique.

Determine capacity with actual strengths, rather than specified or assumed material strengths and characteristics. Concrete strength is to be found from records, or verified by suitable tests. If no data is available, the specified design strength is to be assumed and appropriately increased for maturity. All new designs assume the plan-specified concrete properties. Post-construction records will include updated concrete properties.

6A.5.11.5—Service Limit State

Add: Allowable Service Limit stresses, given in FDOT Tables 6A.5.11-1 and 6A.5.11-2, are intended to ensure a minimum level of durability for FDOT bridges that avoids the development or propagation of cracks or the potential breach of corrosion protection afforded to post-tensioning tendons. These stress limits are recommended for the design of new bridges, as well.

C6A.5.11.5C *(add this subsection commentary)*

Type “A” Joints, with minimum bonded longitudinal reinforcement among cast-in-place joints, are limited to a tensile stress of $3\sqrt{f_c}$ or $6\sqrt{f_c}$ (psi) for the Inventory level. (Reference: AASHTO Guide Specification for Segmental Bridges).

Type “A” Epoxy Joints with discontinuous reinforcement are limited to a tensile stress of zero tension for Inventory (AASHTO Guide Specification for Segmental Bridges and LRFD Table 5.9.4.2.2-1). Operating stress is similarly limited to zero tension, or 200psi for joints in good condition (the tension strength of properly prepared epoxy joints exceeds concrete tension strength).

Type “B” Dry Joints with external tendons were designed to a longitudinal tensile stress limit of zero. In 1989, a requirement for 200 psi residual compression was introduced with the first edition of the AASHTO Guide Specification for Segmental Bridges. This was subsequently revised in 1998 to 100 psi compression. Service level design inventory ratings shall be based on a residual compression of 100 psi for dry joints. For design operating, legal, and permit ratings, the limit is zero tension. (Reference: AASHTO Guide Specification for Segmental Bridges and LRFD Table 5.9.4.2.2-1).

For all joint types, longitudinal Inventory stress limits are similar to Operating stress limits; reduced reliability is attained by using the number of striped lanes.

A check of the principal tensile stress has been introduced to verify the adequacy of webs for longitudinal shear at service. The Service limit state principal stress rating factor is the ratio between the live load shear stress required to induce the maximum principal tensile stress to that induced by the live load factor shown in FDOT Table 6A.5.11-1. The check is made at the neutral axis, or at the critical elevation, and it includes torsion effects. Sections should be considered only at locations greater than “H/2” from the edge of the bearing surface or face of diaphragm, where classical beam theory applies: i.e. away from discontinuity regions. In general, verification at the elevation of the neutral axis may be made without regard to any local transverse flexural stress in the web itself given that in most large, well-proportioned boxes the maximum web shear force and local web flexure are mutually exclusive load cases. This is a convenient simplification. However, should the neutral axis lie in a part of the web locally thickened by fillets, then the check should be made at the most critical elevation, taking into account any coexistent longitudinal flexural stress. Also, if the neutral axis (or critical elevation) lies within 1 duct diameter of the top or bottom of an internal, grouted duct, the web width for calculating stresses should be reduced by half the duct diameter.

6A.5.11.6—System Factors: ϕ_s

Replace subsection with: For longitudinal flexure, apply FDOT Table 6A.5.11.6-1.

Replace Table 6A.5.11.6-1 with:

FDOT Table 6A.5.11.6-1, System Factors (ϕ_s) for Post-Tensioned Concrete Girders

Girders	Span Type	Hinges Required for Mechanism	ϕ_s			
			Number of Tendons per Web			
			1	2	3	4
2	Interior	3	0.85	0.90	0.95	1.00
	End	2	0.85	0.85	0.90	0.95
	Simple	1	0.85	0.85	0.85	0.90
3 or 4	Interior	3	1.00	1.05	1.10	1.15
	End	2	0.95	1.00	1.05	1.10
	Simple	1	0.90	0.95	1.00	1.05
5 or more	Interior	3	1.05	1.10	1.15	1.20
	End	2	1.00	1.05	1.10	1.15
	Simple	1	0.95	1.00	1.05	1.10

6A.5.12—Rating of Reinforced Concrete Box Culverts

Replace Table 6A.5.12.5-1 with:

FDOT Table 6A.5.12.5-1—Limit States and Load Factors for Culvert Load Rating

Description	Minimum	Maximum	LL mpf ³
DC _{Component Dead Load}	0.90	1.25	NA
EV ^{1,2} _{Vertical Earth}	0.90	($\eta=1.05$)(1.30)	NA
EH ^{1,2} _{Horizontal Earth}	1.00	($\eta=1.05$)(1.35)	NA
LL ² _{HL93 Inventory}	0	1.75	1.20
LL ² _{HL93 Operating}	0	1.35	1.20
LL ² _{Legal Operating}	0	1.35	1.00
LL ² _{FL120 Permit, Existing}	0	1.35	1.00
LL ² _{FL120 Permit, New Section}	0	1.35	1.20

1. Simplify the assessment by assuming that the pavement and road base is 120pcf soil; avoid separate computations for DW and ES (wearing surface and earth surcharge).
2. Where “h” is the height of soil, use
 - $F_e \cdot (120 \text{ pcf}) \cdot (h)$ = max & min vertical earth load (F_e at LRFD 12.11.2.2.1-2)
 - $(60 \text{ pcf}) \cdot (h)$ = maximum horizontal earth load
 - $(60 \text{ pcf}) \cdot (h)$ = maximum horizontal live load, equivalent surcharge height
 - $(30 \text{ pcf}) \cdot (h)$ = minimum horizontal earth load
3. Only consider one lane loaded, and apply the appropriate single-lane live load multiple presence factor (mpf) to the distribution factor lateral to the effective span length.

CFDOT Table 6A.5.12.5-1 (add this table commentary)

While $\text{mpf}_{\text{FL120 Permit, Existing}} = 1.00$ for existing culverts and existing sections of culverts, $\text{mpf}_{\text{FL120 Permit}} = 1.20$ for new culverts and new portions of a culvert extension in design. The inconsistency is intended. Historically, Florida constructed culverts under Allowable Stress Design with more than adequate capacity. With the 2013 Interim Revisions and $\text{mpf}_{\text{FL120 Permit, Existing}} = 1.00$, the State can (1) continue with the capabilities of its existing structures, (2) avoid needless replacement, and (3) fully adopt LRFR. For new culverts, $\text{mpf}_{\text{FL120 Permit, Existing}} = 1.20$ will help to ensure that new culverts will accommodate future fill depths, live loads, and methodologies.

For additional guidance, see SDG 3.15, and the culvert example at:

<http://www.fdot.gov/maintenance/LoadRating.shtm>

6A.6—STEEL STRUCTURES

6A.6.4.1—Limit States, Design Load Rating

Replace the second paragraph with: Bridges shall not be rated for fatigue. If fatigue crack growth is anticipated, use Section 7 of the MBE to develop an estimate of the remaining fatigue life; thoroughly document and explain all assumptions and interpretations.

6A.6.13—Moveable Bridges *(add this subsection)*

For new bascule bridges, see SDG 8.4, and show that the Strength I Design Operating rating exceeds 1.0 when span locks are disengaged; however report the Strength I Operating Rating with the span locks engaged. For existing bridges, contact the District Structures Maintenance Engineer for specific instructions.

6A.8—POSTING OF BRIDGES

Add: Posting of weight restrictions on bridges shall follow the procedures given in Chapter 7 of this **Manual**.

6A.8.2—Posting Loads

*Strike any reference to AASHTO legal loads, and replace with the Florida Legal Loads as defined in the Appendix of this **Manual**.*

6A.8.3—Posting Analysis

Replace subsection with: The safe posting load shall be taken as the weight in tons for each Florida legal load truck multiplied by the corresponding rating factor. A Bridge Owner may close a structure at any posting threshold, but bridges with an operating rating less than 3 tons for any Florida legal load must be closed.

Appendix A6A—Load and Resistance Factor Rating Flow Chart

Remove entire subsection (use FDOT Figures 2-1 and 2-2)

Appendix B6A—Limit States and Load Factors for Load Rating

Remove entire subsection (use FDOT Table 6A.4.2.2-1)

Appendix D6A—AASHTO Legal Loads

*Remove entire subsection (use the Appendix to this **Manual**).*

Chapter 6 Part B: Allowable Stress Rating and Load Factor Rating

6B.1—GENERAL

Add: All Load Rating Analyses must comply with Chapter 2 of this **Manual**.

6B.1.1—Application of Standard Design Specifications

Replace subsection with: Except as specifically modified in this **Manual**, or upon direct approval from the Department, explicitly follow the most recent editions of:

- AASHTO Std. Spec. for Highway Bridges
- AASHTO Guide Spec. for Horizontally Curved Steel Girder Highway Bridges
- AASHTO Std. Spec. for Movable Highway Bridges

6B.5—NOMINAL CAPACITY: C

Add: **FDOT Table 6B.5.3—LFR Limit States and Load Factors**

Bridge Type	Limit	DL _{max}	LL	LL
			Inventory	Operating
Steel	Strength ¹	1.30	2.17	1.30
	Service ²	1.00	1.67	1.00
Reinforced Concrete	Strength ¹	1.30	2.17	1.30
	Service ²	NA	NA	NA
Prestressed Concrete	Strength ¹	1.30	2.17	1.30
	Service ²	1.00	1.00	NA
Post-Tension I-Girder ³	Strength ¹	1.30	2.17	1.30
	Service ²	1.00	1.00	NA
Timber ⁴	Strength ¹	NA	NA	NA
	Service ²	NA	NA	NA

Notes on following page.

Notes, FDOT Table 6B.5.3:

1. “Strength” includes flexure and shear; consider axial effects where warranted.
2. “Service” means the allowable tension limit for the beam material.
3. For segmental box girders, use LRFR with FDOT Tables 6A.5.11-1 and 6A.5.11-2.
4. LFR excludes timber; use LRFR or ASR.

6B.5.2.4—Concrete

Replace subsection with: Unknown concrete strengths may be estimated with FDOT Table 6A.5.2.1-1—Minimum Strength of Concrete by Year of Construction.

6B.5.3.2—Reinforced Concrete

Replace subsection with: Unknown concrete reinforcement strength may be estimated with FDOT 6A.5.2.2-1—Yield Strength of Reinforcing Steel.

6B.5.3.3—Prestressed Concrete

*Remove the Prestressing Steel Tension check (see C6A.5.4.2.2b, this **Manual**).*

Add: For prestressed girders exhibiting distress or corrosion, consider using LRFR.

6B.6—LOADINGS

Add: Live load tables are given in the Appendix of this **Manual**.

6B.6.2—Rating Live Load

Add: Omit the 24-kip military tandem at Std.Spec. 3.7.4.

C6B.6.2 *(add this subsection commentary)*

This coheres with past policy, and preserves a stable live loading model for permit routing. HS20 Design has considered the tandem for all Interstate bridges since 1976 Std.Spec. Interims. Meanwhile HS20 Evaluation has traditionally excluded the tandem (see MBE at Page A-72, MBE at Table C6B-1, 1982 FDOT Load Rating Manual at Plate I, 1995 Load Rating Manual at Table VII-2, FDOT BARS customization file "BigJohn.std," the Pontis load rating dataset, and the 2013 load rating calculations for Bridge No. 750004).

6B.6.2.3—Lane Loads

Replace subsection with: The HS20 vehicle considers point-and-lane loading.

6B.6.2.4—Sidewalk Loadings

Replace subsection with: Unless site-specifics suggest otherwise, do not apply pedestrian loading.

6B.6.4—Impact.

Replace subsection with: Typically apply full impact per Std. Spec. See Chapter 7 for impact reductions. Add to Std.Spec. 3.8.2.2: When utilizing Eq. 3-1 for shear impact due to truck loads, the length L may be interpreted as the distance from the point under consideration to the nearest reaction; alternatively, shear impact for axle loading may be taken as 30%.

6B.7—POSTING OF BRIDGES

6B.7.1—General

Replace the third paragraph with: If a concrete culvert with depths of fill 2.0 ft or greater with known details or with unknown components (such as culverts without plans) has been carrying normal traffic for an appreciable period and is in fair or better condition, as determined by a physical inspection of the culvert by a qualified inspector and documented in the inspection report, the culvert may be assigned an inventory load rating factor of 0.90 and an operating load rating factor of 1.50 for the HS-20 design load and need not be posted for restricted loading; these rating factor levels are less than those required by FDOT Fig.2-2, which precludes extension or widening without analytical proof of adequate capacity. The load rating shall be documented in accordance with this *Manual*.

6B.7.2—Posting Loads

Replace subsection with: For LFR ratings, evaluate the Florida Legal Loads as depicted within the Appendix. LFR is limited to bridges whose maximum span is less than 200 feet (FDOT Figure 2-1). Simply use one truck, for LFR/ASR; omit truck trains, and partial-weight combinations. Assume the same legal loads are in each loaded lane; do not mix trucks. Replace the AASHTO legal loads with the Florida Legal Loads shown in the Appendix of this *Manual*.

Chapter 7: Posting of Bridges and Posting Avoidance

7.1—GENERAL

For bona-fide emergencies, immediately do all things necessary to protect public safety. For non-emergency posting, follow the provisions within this Chapter.

If load rating calculations conclude that any of the Florida Legal Loads, as defined in the Appendix to this *Manual*, have an operating rating factor less than 1.0, then the bridge must be posted for weight within 30 days after receipt of official posting notification from the Department.

Post bridges in accordance with FDOT Standard Index No. 17357. Florida posts with three truck silhouettes:

- Single unit trucks: SU2, SU3, and SU4.
- Combination trucks with a single trailer: C3, C4, and C5.
- Combination truck with two trailers or a single unit truck with one trailer: ST5.

For each silhouette/class, post the lowest sub-legal rating, and truncate. For example:

$RF_{SU2} = 1.12$	$GVW_{SU2} = 17$ tons	$RATING_{SU2} = 19.0$ tons
$RF_{SU3} = 0.89$	$GVW_{SU3} = 33$ tons	$RATING_{SU3} = 29.5$ tons
$RF_{SU4} = 0.99$	$GVW_{SU4} = 35$ tons	$RATING_{SU4} = 34.6$ tons

Here, the SU posting is 29 tons. 29.5 is truncated, or rounded down. The SU2 is neglected, because the SU2 rating is greater than the SU2 gross vehicle weight (GVW).

7.2—WEIGHT POSTING PROCEDURES, STATE-MAINTAINED BRIDGES

When weight restrictions are required on a Department-maintained bridge, the District Structures Maintenance Engineer (DSME) will:

Analyze the structure, consider posting-avoidance techniques, and recommend posting levels. Consult with the State Load Rating Engineer.

Solicit recommendations from the District Traffic Operations Engineer for sign location and design, and order signs from the Lake City Sign Shop.

Write a posting narrative. Explain the cause of the low load rating. State the effects of posting, particularly for emergency vehicles, and include a detour map.

Finally, detail the proposed remedy (repair, strengthening, or replacement), an estimate of its cost and a timeline for accomplishing the proposed remedy.

Send the posting narrative, and the load rating summary, to the District Maintenance Engineer, and the State Structures Maintenance Engineer.

The State Structures Maintenance Engineer will, within 14 days of receipt of the posting narrative and load rating summary, issue a determination upon the request for weight restriction to the DSME. Approvals require signed concurrence from the State Structures Maintenance Engineer, Director Office of Maintenance, and the Secretary of the Department of Transportation.

Prior to the removal of a weight restriction on a Department-maintained bridge, provide a new load rating to the State Structures Maintenance Engineer.

7.3—WEIGHT POSTING PROCEDURE, BRIDGES NOT MAINTAINED BY THE DEPARTMENT

When weight restrictions are required on a bridge that is not maintained by the Department, users of this *Manual* will follow this procedure. The Department or its consultant will analyze the bridge, and the Department's District Local Bridge Coordinator will forward weight posting recommendations to the local agency bridge owner.

The local agency bridge owner shall post the bridge, and notify the Department's District Local Bridge Coordinator that the posting recommendation has been put into effect. If the required weight posting recommendation is not acted upon by the local agency bridge owner within 30 days of the initial notification by the District Local Bridge Coordinator, the Department shall post the bridge immediately, and all posting costs incurred by the Department shall be assessed to the local agency bridge owner.

The local agency bridge owner may subsequently perform its own analysis. However, such analysis does not exempt the local agency bridge owner from taking the mandatory steps to post the bridge within the 30 days, and any conclusions reached in the subsequent analysis finding that the posting restriction is not required must be accepted by the Department before load restrictions are removed.

7.4—POSTING AVOIDANCE

Posting avoidance modifies AASHTO design specifications to mitigate weight limit and permit mobility restrictions at existing bridges. Posting avoidance techniques are not applicable to new bridges, rehabilitation projects, or widening projects. However several techniques are available for existing bridges; select the ones that apply. Within the load rating narrative, explain and justify the selection.

ROUND-UP. Rating factor results from the approximate AASHTO distribution equations may be rounded-up by up to 5%. SDG 7.1.1.C.1 also permits rounding for widenings, but confines the provision to approximately-distributed LRFR results.

REFINED ANALYSIS. Analytical refinements may be used to improve load distribution. Permissible methods include finite element analysis, and moment redistribution (LRFD 4.6.4, and Std.Spec. 10.48.1.3).

DYNAMIC ALLOWANCE FOR IMPROVED SURFACE CONDITIONS. Where the transitions from the bridge approaches to the bridge deck across the expansion joints are smooth and where there are minor surface imperfections or depressions on the bridge deck, the dynamic load allowance may be reduced to 20%.

BARRIER STIFFNESS. An analysis may reasonably consider stiffening effects from parapets and barriers; additionally consider the adverse effects.

STRIPED LANES. Striped lanes may be used for Service limits.

STEEL SERVICE. An analysis may neglect Steel Service if these factors are considered: fatigue, Average Daily Truck Traffic (ADTT), and the replacement schedule. For example, bridges with exceptionally low traffic, like certain water management structures, may neglect Steel Service with no additional analytical consideration. However steel structures on more typical throughways must consider ADTT and fatigue before neglecting the Steel Service limit.

REDUCED DEAD LOAD FACTOR. A lower dead load factor of 1.15 may be considered when dimensions are thoroughly and accurately field verified. When reducing the dead load factor to 1.15, select unit weights with care. Consider the aggregate type and the amount of steel reinforcement.

Chapter 8: Load Rating of Bridges through Load Testing

GENERAL

To more accurately approximate load carrying capacity, the Department uses nondestructive load testing as described by MBE Section 8. Testing typically seeks an enhanced rating, and load testing can show that a bridge has additional capacity well beyond a traditional analysis. However testing can also discover stress spiking, or unforeseen deflections, which diminish the rating. In either case, whether the results are stronger or weaker than an approximate analysis would conclude, those load test results will better inform design and maintenance policy.

LOAD TEST CANDIDATES

Load test candidates either restrict the flow of trucks, or cannot be satisfactorily analyzed by traditional means. Annually, the State Load Rating Engineer will confer with District Structures Maintenance Engineers, the Permitting Office, and the Structures Research Center, to develop and refine a load test list. The State Load Rating Engineer will establish priorities, and the Structures Research Center will schedule the load tests in conjunction with the Districts.

It is anticipated that the Structures Research Center will perform a minimum of three (3) load tests each fiscal year. Within 60 days of completion of the load test, The Structures Research Center will send the load test report to the District Structures Maintenance Engineer and the State Load Rating Engineer. Within 14 days of receipt, the District Structures Maintenance Engineer will update the BrM/Pontis database with the results of the load test report.

LOAD TEST REPORTS

In addition to the “Complete Load Rating” requirements, specified in Chapter 2 of this *Manual*, load test reports also feature an expanded narrative that discusses test procedure and analytical interpretation.

APPENDIX

The Appendix defines live loads, and offers example Load Rating Summary Forms. For the Load Rating Summary Form Excel worksheet, and additional materials, see: <http://www.fdot.gov/maintenance/LoadRating.shtm>

LRFR HL93 & FL120 PERMIT

Axles in kip. Gage widths are 6 feet. Apply patch lane loads for maximum effects.

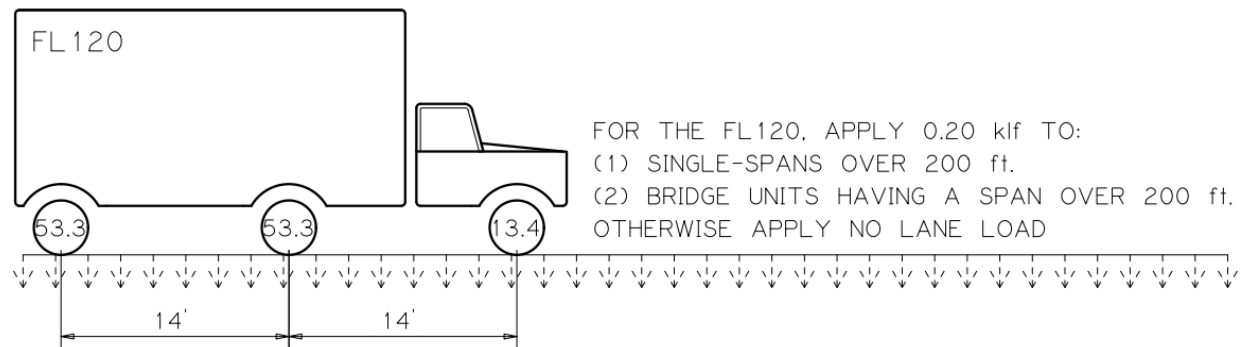
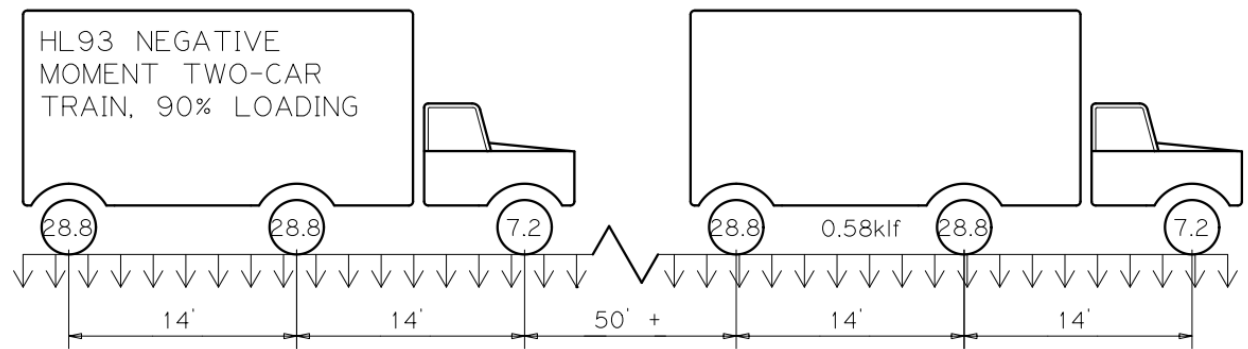
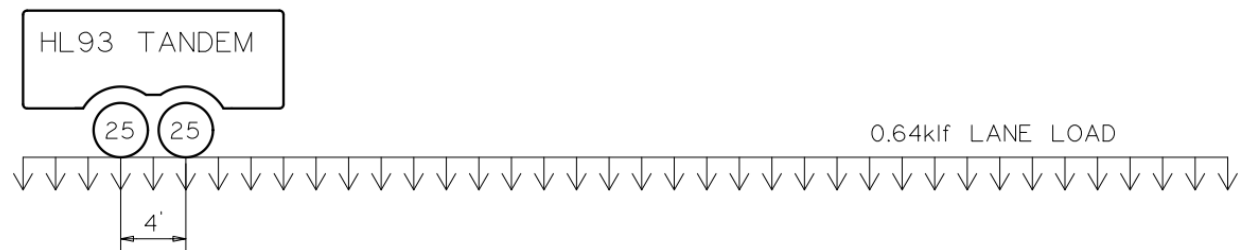
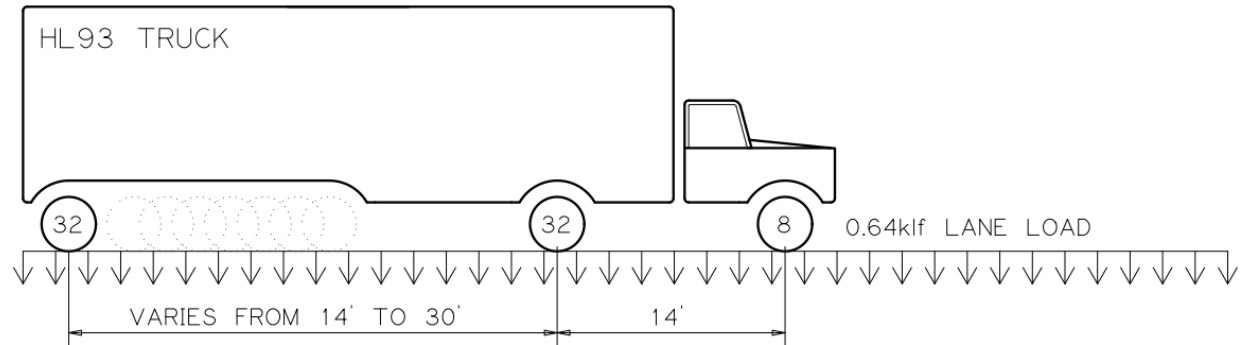

FLORIDA LEGAL LOADS

Axle Loading is in kip. Gage widths are 6 feet.

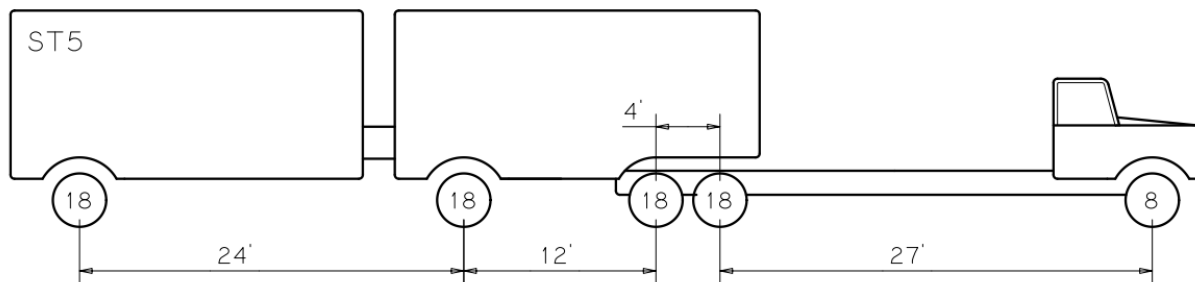
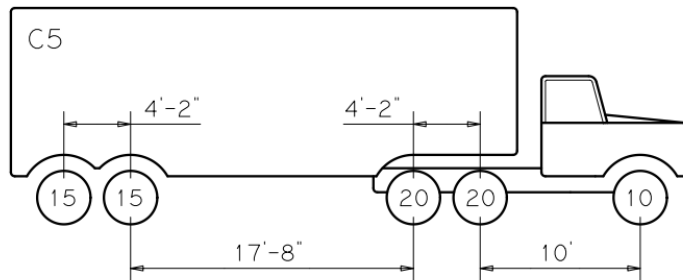
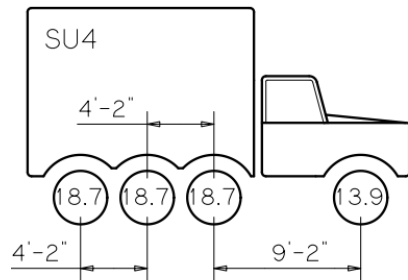
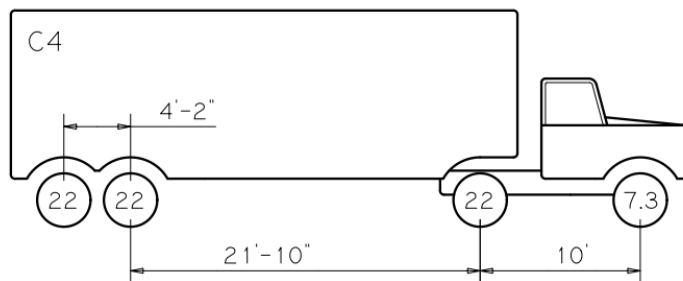
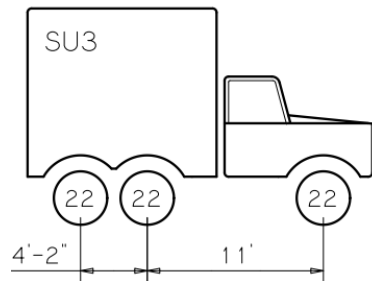
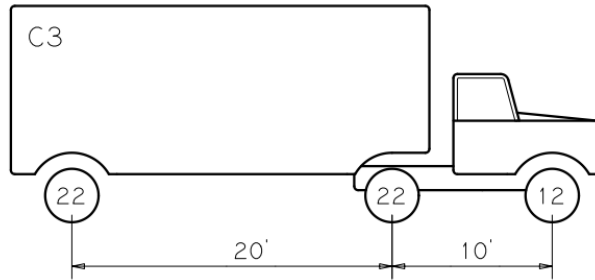
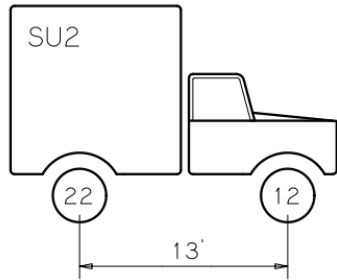

LRFR LEGAL LOAD COMBINATIONS

For all spans and effects, consider a single legal truck.

For spans exceeding 200 feet, or for bridge units with one span that exceeds 200 feet, consider one truck at 75% axle weights with full impact, combined with 100% 0.2klf lane loading at 0% impact. Use patch lane loading (continuous or discontinuous) to obtain the maximum effects. The figure below depicts maximum positive moment in Span 1.

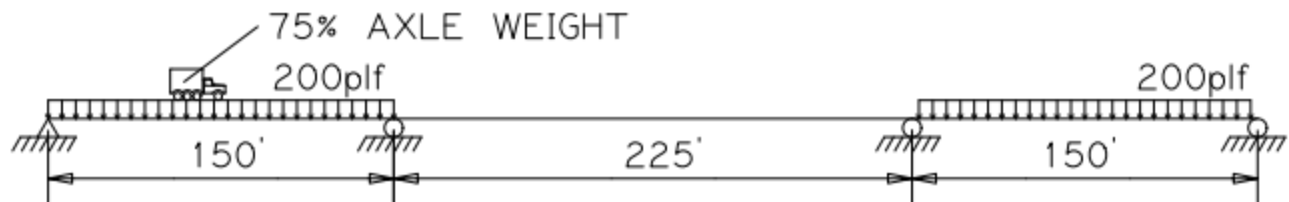

For continuous structures of any length, negative moments and reactions at interior supports shall consider two legal trucks at 75% axle weights with full impact, combined with 100% 0.2klf lane loading at 0% impact. Separate the two trucks with 30 feet clear spacing, and point the trucks in the same direction. The figure below depicts the SU4 negative moment combination for Pier 2.

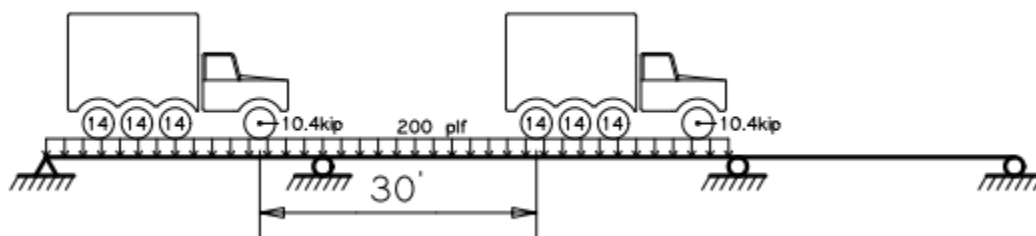

LFR LEGAL LOAD COMBINATIONS

For all spans and effects, consider a single legal truck. This **Manual** prohibits LFR for spans exceeding 200 feet, so analysts need not apply the MBE 6B.7.2 100% weight truck train.

LFR HS20, EVALUATION DESIGN LOADING

Axles in kip. Gage widths are 6 feet. Apply patch lane loads for maximum effects.

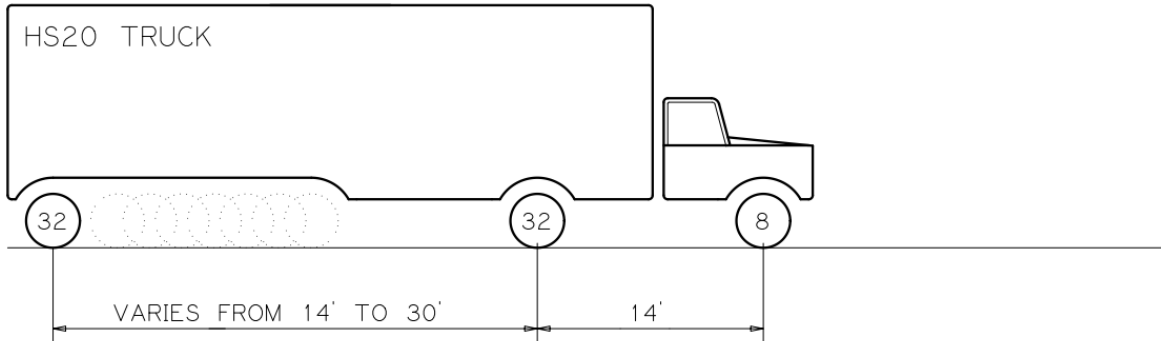

HS20 POINT-AND-LANE LOAD, SHEAR

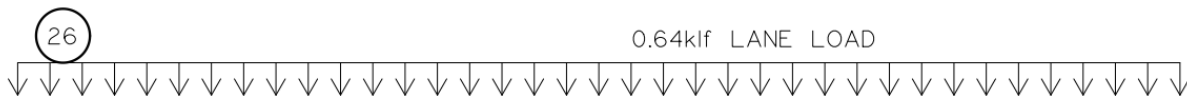

HS20 POINT-AND-LANE LOAD, MOMENT

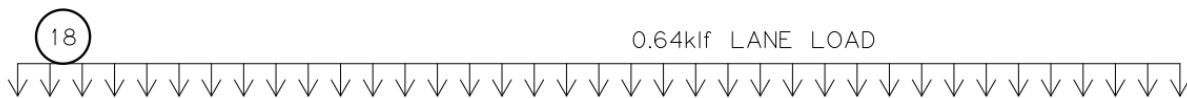

HS20 POINT-AND-LANE LOAD, NEGATIVE MOMENT

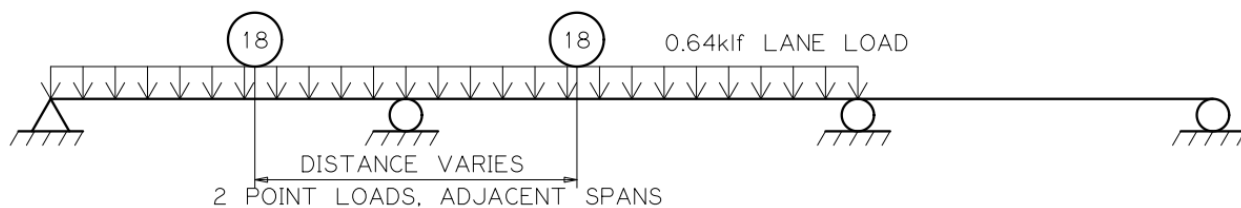

LRFR LIVE LOAD WITH IMPACT, PER LANE

Span	IM _{AXL}	IM _{LANE}	HL93	FL120	SU2	SU3	SU4	C3	C4	C5	ST5
(ft)	(%)	(%)	(k-ft)	(k-ft)	(k-ft)	(k-ft)	(k-ft)	(k-ft)	(k-ft)	(k-ft)	(k-ft)
5	33%	0%	55.2	88.7	36.6	36.6	31.1	36.6	36.6	33.3	29.9
10	33%	0%	114.4	177.3	73.2	91.7	82.9	73.2	91.7	83.4	76.6
15	33%	0%	205.0	266.0	109.7	162.7	176.2	109.7	162.7	147.9	134.9
20	33%	0%	301.0	354.7	146.3	234.8	269.4	153.3	234.8	213.5	193.9
30	33%	0%	506.2	625.4	243.3	440.3	476.8	264.0	380.1	376.9	351.4
40	33%	0%	727.9	997.0	354.4	658.8	708.2	387.6	525.8	543.1	529.9
60	33%	0%	1359.2	1787.8	578.5	1096.7	1172.3	754.9	956.6	1061.7	887.9
80	33%	0%	2059.9	2582.2	803.6	1535.1	1637.1	1124.8	1436.7	1591.4	1356.0
100	33%	0%	2825.5	3378.0	1029.1	1973.7	2102.2	1495.7	1919.8	2122.0	1884.9
150	33%	0%	5020.9	5370.1	1593.6	3070.6	3265.4	2424.7	3132.6	3450.1	3210.8
200	33%	0%	7617.2	7363.6	2158.4	4167.7	4428.9	3354.6	4348.3	4779.2	4538.8
200.1	33%	0%	7622.8	8368.1	2620.4	4169.9	4431.3	3517.8	4350.7	4781.8	4541.4
250	33%	0%	10614	10920	3605	5511	5757	4776	5735	6144	5962
300	33%	0%	14010	13602	4716	7021	7317	6161	7336	7828	7647

Span	IM _{AXL}	IM _{LANE}	HL93	FL120	SU2	SU3	SU4	C3	C4	C5	ST5
(ft)	(%)	(%)	(kip)	(kip)	(kip)	(kip)	(kip)	(kip)	(kip)	(kip)	(kip)
5	33%	0%	44.2	70.9	29.3	34.1	29.0	29.3	34.1	31.0	28.7
10	33%	0%	56.4	70.9	29.3	46.3	43.5	29.3	46.3	42.1	38.3
15	33%	0%	62.4	75.7	31.4	50.4	53.9	34.6	50.4	46.5	41.5
20	33%	0%	66.3	92.2	34.8	59.5	61.4	37.2	52.4	51.5	47.9
30	33%	0%	75.6	109.9	38.3	68.9	72.0	39.9	58.4	57.6	55.9
40	33%	0%	86.2	122.4	40.0	73.6	77.2	47.9	66.7	66.5	59.9
60	33%	0%	100.1	134.8	41.8	78.4	82.5	56.7	77.0	75.8	71.8
80	33%	0%	110.2	141.0	42.6	80.7	85.2	61.2	82.1	83.5	77.8
100	33%	0%	118.8	144.7	43.1	82.1	86.8	63.8	85.2	88.1	81.4
150	33%	0%	137.8	149.7	43.8	84.0	88.9	67.4	89.3	94.2	86.2
200	33%	0%	155.3	152.2	44.2	85.0	89.9	69.2	91.3	97.2	90.9
200.1	33%	0%	155.3	172.2	53.1	85.0	89.9	71.9	91.3	97.2	90.9
250	33%	0%	172.2	178.6	58.3	89.1	92.9	77.7	94.4	99.3	95.5
300	33%	0%	188.8	184.6	63.4	94.4	98.2	83.2	100.0	105.2	102.0

Replace MBE Tables E6A-1 and E6A-2 with the one above, noting corrections to the MBE for the HL93. The live load for some Legal vehicles may increase step-wise, at 200 feet, when the 75% axle and 100% 0.20klf dual-car train begins to apply; the combination may be conservatively considered for shorter span lengths, also. See the Load Rating Summary (Excel) at sheet "LL," for additional span lengths.

LFR LIVE LOAD WITH NO IMPACT, PER LANE

Span	IM _{AXL}	IM _{LANE}	HS20	SU2	SU3	SU4	C3	C4	C5	ST5
(ft)	(%)	(%)	(k-ft)	(k-ft)	(k-ft)	(k-ft)	(k-ft)	(k-ft)	(k-ft)	(k-ft)
5	0%	0%	40.0	27.5	27.5	23.4	27.5	27.5	25.0	22.5
10	0%	0%	80.0	55.0	68.9	62.3	55.0	68.9	62.7	57.6
15	0%	0%	120.0	82.5	122.3	132.5	82.5	122.3	111.2	101.4
20	0%	0%	160.0	110.0	176.6	202.6	115.3	176.6	160.5	145.8
30	0%	0%	282.1	183.0	331.0	358.5	198.5	285.8	283.4	264.2
40	0%	0%	449.8	266.5	495.3	532.5	291.4	395.4	408.4	398.4
60	0%	0%	806.5	435.0	824.6	881.5	567.6	719.2	798.3	667.6
80	0%	0%	1164.9	604.2	1154.2	1230.9	845.7	1080.3	1196.5	1019.6
100	0%	0%	1523.9	773.8	1484.0	1580.6	1124.6	1443.5	1595.5	1417.2
150	0%	0%	2475.0	1198.2	2308.7	2455.2	1823.0	2355.3	2594.1	2414.2
200	0%	0%	4100	1623	3134	3330	2522	3269	3593	3413
200.1	0%	0%	4104	3439	6349	6407	4210	5153	5641	4020
250	0%	0%	6125	5180	9638	9850	6306	7616	8304	6152
300	0%	0%	8550	7371	13645	13773	8966	10775	11741	8596

Span	IM _{AXL}	IM _{LANE}	HS20	SU2	SU3	SU4	C3	C4	C5	ST5
(ft)	(%)	(%)	(kip)	(kip)	(kip)	(kip)	(kip)	(kip)	(kip)	(kip)
5	0%	0%	32.0	22.0	25.7	21.8	22.0	25.7	23.3	21.6
10	0%	0%	32.0	22.0	34.8	32.7	22.0	34.8	31.7	28.8
15	0%	0%	34.1	23.6	37.9	40.5	26.0	37.9	35.0	31.2
20	0%	0%	41.6	26.2	44.7	46.1	28.0	39.4	38.7	36.0
30	0%	0%	49.6	28.8	51.8	54.1	30.0	43.9	43.3	42.0
40	0%	0%	55.2	30.1	55.4	58.1	36.0	50.1	50.0	45.0
60	0%	0%	60.8	31.4	58.9	62.0	42.7	57.9	57.0	54.0
80	0%	0%	63.6	32.1	60.7	64.0	46.0	61.7	62.8	58.5
100	0%	0%	65.3	32.4	61.7	65.2	48.0	64.0	66.2	61.2
150	0%	0%	74.0	33.0	63.2	66.8	50.7	67.1	70.8	64.8
200	0%	0%	90.0	33.2	63.9	67.6	52.0	68.7	73.1	68.3
200.1	0%	0%	90.0	76.3	140.6	145.0	92.2	117.3	123.4	94.3
250	0%	0%	106.0	91.3	168.3	169.3	111.1	139.1	147.0	112.7
300	0%	0%	122.0	104.9	193.7	197.5	126.5	155.9	166.5	125.9

Replace MBE Tables C6B-1 and C6B-2 with the one above. For LFR, the MBE reports live load in wheel-lines (half-axle, or half-lane); this table uses 1 lane. For spans over 200 feet, the LFR truck train applies to one lane; use LRFR methodology for spans over 200 feet. See the Load Rating Summary (Excel) at sheet “LL,” for additional span lengths.

RATING FACTORS (RFs) FOR PERMITS

Permits are typically routed by comparing the available capacity ($RF \cdot LL_{\text{Reference Vehicle}}$) to the permit live load, for the spans under consideration. The table below illustrates the minimum single-span simply-supported longitudinal Operating Rating Factors needed to pass all blanket permit trucks in Florida, considering both moment and shear.

SPAN	LRFR	LRFR	LFR
Length	HL93	FL120	HS20
(ft)	(RF_{needed})	(RF_{needed})	(RF_{needed})
5	1.09	0.68	1.13
10	1.21	0.96	1.60
15	1.20	0.99	1.64
20	1.24	0.97	1.62
30	1.29	0.99	1.65
40	1.32	0.96	1.61
60	1.22	0.93	1.55
80	1.23	0.98	1.63
100	1.24	1.04	1.73
150	1.32	1.22	1.85
200	1.30	1.33	1.72
200.1	1.30	1.18	1.72
250	1.24	1.20	1.55
300	1.18	1.20	1.40

For example, HL93 column two (2) is:

$$\max \left(\left(\frac{\max(LL_{\text{Permits.Moment}}(L_{\text{span}}))}{\max(LL_{\text{HL93.Moment}}(L_{\text{span}}))} \right), \left(\frac{\max(LL_{\text{Permits.Shear}}(L_{\text{span}}))}{\max(LL_{\text{HL93.Shear}}(L_{\text{span}}))} \right) \right)$$

For example, say the span length is 100ft. If $RF_{\text{FL120}} = 1.04$, $RF_{\text{CRANE 3}}$ is inferred as:

$$LL_{\text{FL120}} = 3378 \text{ kip}\cdot\text{ft}$$

$$LL_{\text{CRANE 3}} = 3500 \text{ kip}\cdot\text{ft}$$

$$RF_{\text{CRANE 3}} = 1.04 \cdot 3378 / 3500 = 1.00$$

$RF_{\text{FL120}} = 1.04$ corresponds to the FL120 value at left, for a span length of 100ft., because the Crane 3 governs the 100ft. span in flexure, over all other permit vehicles.

EXAMPLE LOAD RATING SUMMARY 1

Bridge No.	991957	Analysis Method:	ASR - Allowable Stress	FDOT Bridge Load Rating Summary Form (Page 1 of 1)	
Bridge Name	Tamarkan over Kwai				
Description	3 Simply-supported spans, 26-60-26 feet. 60ft. T-Beam Governs.				

Rating Type	Rating Type	Gross Axle Weight (tons)	Moment/Shear/Service		Dead Load Factor	Live Load Factor	Live Load Distrib. Factor (axes)	Rating Factor	Span No. - Girder No., Interior/Exterior, %Span-L	Pontis RF-Weight (tons)
Level	Vehicle	Weight	Member Type	Limit	DC	LL	LLDF	RF	Governing Location	RATING
Inventory	HS20	36	Reinf. Concrete	Service	1.00	1.00	0.351	0.551	Beam 2-5, Interior, 50%L	19.8
Operating	HS20	36	Reinf. Concrete	Service	1.00	1.00	0.351	0.751	Beam 2-5, Interior, 50%L	27.1
Permit	FL120	60	Reinf. Concrete	NA	NA	NA				-1.0
Operating Max Span	HS20	36	Reinf. Concrete	Service	1.00	1.00	0.351	0.751	Beam 2-5, Interior, 50%L	27.1
Legal	SU2	17	Reinf. Concrete	Service	1.00	1.00	0.351	1.391	Beam 2-5, Interior, 50%L	23.7
	SU3	33	Reinf. Concrete	Service	1.00	1.00	0.351	0.730	Beam 2-5, Interior, 50%L	24.1
	SU4	35	Reinf. Concrete	Service	1.00	1.00	0.351	0.684	Beam 2-5, Interior, 50%L	23.9
	C3	28	Reinf. Concrete	Service	1.00	1.00	0.351	1.073	Beam 2-5, Interior, 50%L	30.1
	C4	36.7	Reinf. Concrete	Service	1.00	1.00	0.351	0.854	Beam 2-5, Interior, 50%L	31.3
	C5	40	Reinf. Concrete	Service	1.00	1.00	0.351	0.760	Beam 2-5, Interior, 50%L	30.4
	ST5	40	Reinf. Concrete	Service	1.00	1.00	0.351	0.903	Beam 2-5, Interior, 50%L	36.1

<i>Original</i> Design Load	Unknown (original plans NA)	Performed by:	Andrew DeVault	Date:	12/11/14
Rating Type, <i>Analysis</i>	Allowable Stress (AS)	Checked by:	Roger Liu	Date:	12/11/14
Distribution Method	Others	Sealed By:	Andrew DeVault	Date:	12/15/14
Impact Factor	27.0% (axle loading)	FL P.E. No.:	#75796		
FL120 Gov. Span Length	60.0 (feet)	Cert. Auth. No.:	State Agency		
Recommended Posting	30.0 to 39.9% below (0.60+0.700) (Required)	Phone & email:	850-410-5531, andrew.devault@dot.state.fl.us		
Rec. SU Posting	23 (tons)	Company:	FDOT, Office of Maintenance		
Rec. C Posting	30 (tons)	Address:	2740 Centerview Dr. #1B, Tallahassee FL 32399		
Rec. ST5 Posting	36 (tons)	<i>P.E. Seal</i>			
Floor Beam Present?	No				
Segmental Bridge?	No				
Project No. & Reason	NA	Update			
Status	Built				
Software Name, Version	MathCAD				
COMMENTS BY THE ENGINEER					
Page 1/23. Contents: summary, narrative, plans, calcs, check.					
Unknown plans. Fair condition.					
Posting avoidance/mitigation applied.					
Unsealed example; the Bridge No. and name is fictitious.					

This 01-01-2016 table follows the 2016 FDOT Bridge Load Rating Manual, and the BMS Coding Guide. See www.fdot.gov/maintenance/LoadRating.shtm

EXAMPLE LOAD RATING SUMMARY 2

Bridge No. 180021	Analysis Method: LRFR-LRFD	FDOT Bridge Load Rating Summary Form (Page 1 of 1)
Bridge Name SR50 over Abandoned RR at Mabel		
Description Four simple spans, 35 - 35 - 56 - 56 feet. Composite steel girder.		

Rating Type	Rating Type	Gross Axle Weight (tons)	Moment/Shear/Service	Dead Load Factor	Live Load Factor	Live Load Distrib. Factor (axes)	Rating Factor	Span No. - Girder No., Interior/Exterior, %Span-L	Pontis RF-Weight (tons)
Level	Vehicle	Weight	Member Type Limit	DC	LL	LLDF	RF	Governing Location	RATING
Inventory	HL93	36	Steel Service	1.00	1.30	0.698	0.907	Beam 3-3, Interior, 50%L	32.6
Operating	HL93	36	Steel Service	1.00	1.00	0.698	1.179	Beam 3-3, Interior, 50%L	42.4
Permit	FL120	60	Steel Strength, Shear	1.25/0.90	1.35	0.814	0.937	Beam 2-3, Interior, 0%L	56.2
Permit Max Span	FL120	60	Steel Strength, Moment	1.25/0.90	1.35	0.698	0.965	Beam 3-3, Interior, 50%L	57.9
Legal	SU2	17	Steel Service	1.00	1.30	0.698	2.030	Beam 3-3, Interior, 50%L	34.5
	SU3	33	Steel Service	1.00	1.30	0.698	1.092	Beam 3-3, Interior, 50%L	36.0
	SU4	35	Steel Service	1.00	1.30	0.698	1.023	Beam 3-3, Interior, 50%L	35.8
	C3	28	Steel Service	1.00	1.30	0.698	1.634	Beam 3-3, Interior, 50%L	45.8
	C4	36.7	Steel Service	1.00	1.30	0.698	1.295	Beam 3-3, Interior, 50%L	47.5
	C5	40	Steel Service	1.00	1.30	0.698	1.164	Beam 3-3, Interior, 50%L	46.6
	ST5	40	Steel Service	1.00	1.30	0.698	1.362	Beam 3-3, Interior, 50%L	54.5

<i>Original</i> Design Load	HS15 or H-15-S12	Performed by:	Will Po	Date:	11/11/14
Rating Type, <i>Analysis</i>	Load Testing	Checked by:	Charlie Parker	Date:	12/11/14
Distribution Method	AASHTO Formula	Sealed By:	Mario Bauza	Date:	12/15/14
Impact Factor	33.0% (axle loading)	FL P.E. No.:	#2804119		
FL120 Gov. Span Length	35.0 (feet)	Cert. Auth. No.:	State Agency		
Recommended Posting	A1/Above legal loads. Posting Not Required.	Phone & email:	850-414-5200, will.p@dot.state.fl.us		
Rec. SU Posting	99 (tons)	Company:	FDOT, Office of Maintenance		
Rec. C Posting	99 (tons)	Address:	2007 E Paul Dirac Drive, Tallahassee FL 32310		
Rec. ST5 Posting	99 (tons)	<i>P.E. Seal</i>			
Floor Beam Present?	No				
Segmental Bridge?	No				
Project No. & Reason	NA Update				
Status	Built				
Software Name, Version	Hand Calcs - MathCAD				
COMMENTS BY THE ENGINEER					
Page 1/40. Contents: summary, narrative, plans, calcs, check.					
Fair condition.					
AASHTO-distributed results adjusted by diagnostic load test.					
Unsealed example summary; numbers & names are fictitious.					

This 01-01-2016 table follows the 2016 FDOT Bridge Load Rating Manual, and the BMS Coding Guide. See www.fdot.gov/maintenance/LoadRating.shtm

EXAMPLE LOAD RATING SUMMARY 3

Bridge No. 729999	Analysis Method: LRFR-LRFD	FDOT Bridge Load Rating Summary Form (Page 1 of 1)
Bridge Name I-295 over CSX RR		
Description Four simple spans: 47-89-89-48 feet. Composite prestress girder.		

Rating Type	Rating Type	Gross Axle Weight (tons)	Moment/Shear/Service		Dead Load Factor	Live Load Factor	Live Load Distrib. Factor (axes)	Rating Factor	Span No. - Girder No., Interior/Exterior, %Span-L	Pontis RF-Weight (tons)
Level	Vehicle	Weight	Member Type	Limit	DC	LL	LLDF	RF	Governing Location	RATING
Inventory	HL93	36	Prestressed	Service	1.00	0.80	0.570	1.100	Beam 2-10, Interior, 50%L	39.6
Operating	HL93	36	Prestressed	Strength, Shear	1.25/0.90	1.35	0.870	1.310	Beam 2-10, Interior, 30%L	47.2
Permit	FL120	60	Prestressed	Strength, Shear	1.25/0.90	1.35	0.870	1.020	Beam 2-10, Interior, 30%L	61.2
Permit Max Span	FL120	60	Prestressed	Strength, Shear	1.25/0.90	1.35	0.870	1.020	Beam 2-10, Interior, 30%L	61.2
Legal	SU2	17	Prestressed	NA	NA	NA				-1
	SU3	33	Prestressed	NA	NA	NA				-1
	SU4	35	Prestressed	NA	NA	NA				-1
	C3	28	Prestressed	NA	NA	NA				-1
	C4	36.7	Prestressed	NA	NA	NA				-1
	C5	40	Prestressed	NA	NA	NA				-1
	ST5	40	Prestressed	NA	NA	NA				-1

<i>Original</i> Design Load	HS20 or HS20-S16-44	Performed by:	Miles Davis	Date:	08/17/59
Rating Type, <i>Analysis</i>	LRFR-LRFD	Checked by:	Henri Mancini	Date:	01/01/64
Distribution Method	AASHTO Formula	Sealed By:	David Bowie	Date:	02/23/15
Impact Factor	33.0% (axle loading)	FL P.E. No.:	#999999		
FL120 Gov. Span Length	88.2 (feet)	Cert. Auth. No.:	#999999		
Recommended Posting	At/Above legal loads. Posting Not Required.	Phone & email:	850-414-5200, consultant@firm.com		
Rec. SU Posting	99 (tons)	Company:	Round Midnight Engineering		
Rec. C Posting	99 (tons)	Address:	207 East 30th Street, New York NY 10000		
Rec. ST5 Posting	99 (tons)	<i>P.E. Seal</i>			
Floor Beam Present?	No				
Segmental Bridge?	No				
Project No. & Reason	213387-7-52-01 Widening				
Status	In Design or Construction				
Software Name, Version	Conspan 13.0				
COMMENTS BY THE ENGINEER					
Page 1/90. Contents: summary, narrative, plans, calcs, check.					
Unsealed example summary; numbers & names are fictitious.					

This 01-01-2016 table follows the 2016 FDOT Bridge Load Rating Manual, and the BMS Coding Guide. See www.fdot.gov/maintenance/LoadRating.shtm

SYNOPSIS OF SIGNIFICANT REVISIONS, 2015

The 2015 FDOT Bridge Load Rating Manual rewrote the 2014 Manual. The organization and intent was largely retained. However the word count was reduced significantly, and the following changes were significant:

1. Add an updating procedure, for Technical Revisions.
2. Revise prestress Operating and Permit ratings to Strength, not Service. However retain Service for prestress exhibiting distress or corrosion.
3. Remove the prestress Service I Lower Tendon Limit for LFR and LRFR-FL120. See commentary at C6A.5.4.2.2b.
4. Clarify LRFD prestress shear capacity. Either use the General Method per LRFD, or the "Simplified" method (ACI as modified by LRFD).
5. Narrow LFR and ASR. Exclude LFR and ASR from spans exceeding 200ft.
6. Require Legal Load assessments for LFR and ASR, regardless of the Design Operating Rating.
7. Simplify system factors for steel bridges; do not apply different system factors to different spans on the same bridge unit.
8. Simplify culvert analysis by providing criteria for wall assessments.
9. Remove requirements that older culverts be appraised by LFR. The 2013 LRFD Interims broadened the effective strip width, and LRFR is now similar to LFR.
10. Describe load rating deliverables, and specify the mechanics of their submission and adoption (Chapter 2—Process).
11. Specify what a load rating is, its minimum contents.
12. Simplify segmental analysis. First, for all Design Operating, Legal Operating, and Routine Permit ratings, use $V_{LL,Service} = "0.90 SL,"$ and a single-lane multiple presence factor of 1.0 (consistent). Second, use Inventory Service I transverse $3\sqrt{f_c}$ psi, for all environments, which coheres with LRFD 5.9.4.1.2-1, and redacts slightly aggressive $6\sqrt{f_c}$ psi (conservative, and consistent). Third, redact step-by-step instructions (see Volume 10 A: Load Rating Post-Tensioned Concrete Segmental Bridges, now somewhat outdated). Finally, redact specific instructions for shear in segmentals (defer to the latest LRFD).

SYNOPSIS OF SIGNIFICANT REVISIONS, 2016

The 2016 FDOT Bridge Load Rating Manual largely retains the 2015 Manual. The following changes are notable:

1. Chapter 2—Process: Definition, Complete Load Rating. Add a provision for digital delivery. Specify “unlocked,” and say why.
2. Chapter 2—Process: Table 2-1—Existing Bridges. For load rating reviews coincident to bridge inspections, change the location of the note documenting the review from “Structure Notes” to “Inspection Notes.” Additionally, remove “the results are, by inspection, reasonable” as vague.
3. Chapter 6—Load Rating Analysis: 6A.5.12—Rating of Reinforced Concrete Box Culverts. Rewrite the subsection, provide guidance, and link to an example.

This *Manual* was published in January 2016. Subsequently, on 09-26-2016,

<http://www.dot.state.fl.us/statemaintenanceoffice/...>
was updated to:
<http://www.fdot.gov/maintenance/...>

<http://www.dot.state.fl.us/structures/...>
was updated to:
<http://www.fdot.gov/structures/>