

**FLORIDA DEPARTMENT OF TRANSPORTATION**



**BRIDGE LOAD RATING MANUAL**

**Office of Maintenance**

## **I.1 Purpose**

This Manual establishes procedures for load rating structures, establishes the safe load carrying capacity of structures for permitting overweight vehicles and posting structures that cannot safely carry legal loads.

## **I.2 Authority**

Sections 20.23(4)(a) and 334.048(3), Florida Statutes (F.S.)

## **I.3 Scope and Format**

The requirements related to this procedure affect all Department personnel involved in load rating and posting bridges. In addition, consultants performing load ratings for the Department may be required by contract to follow requirements of this procedure.

The format of this Manual is to provide the requirements in the left column and the commentary in the right column. Section 6 of this Manual addresses specific Department modifications to the AASHTO *Manual for Bridge Evaluation*. These modifications have been added to address Florida's unique bridges.

## **I.4 Abbreviations**

AASHTO – American Association of State and Highway Transportation Officials

ACI - American Concrete Institute

ADTT – Average Daily Truck Traffic

AISC - American Institute of Steel Construction

AREMA - American Railway Engineering and Maintenance-of-Way Association

ASD – Allowable Stress Design

ASR – Allowable Stress Rating

AWS - American Welding Society

DSDE - District Structures Design Engineer

DSDO - District Structures Design Office

DSME - District Structures Maintenance Engineer

DSMO - District Structures Maintenance Office

EOR – Engineer of Record

FCM – Fracture Critical Members

FGB – Florida Greenbook

FHWA - Federal Highway Administration

FDOT - Florida Department of Transportation

LFD – Load Factor Design

LFR – Load Factor Rating

LRFD - Load and Resistance Factor Design

LRFR - Load and Resistance Factor Rating

MBE – Manual for Bridge Evaluation

NBI – National Bridge Inventory

NCHRP – National Cooperative Highway Research Program

PPM - Plans Preparation Manual

SDG - Structures Design Guidelines

SDM - Structures Detailing Manual

SDO - Structures Design Office

SSDE - State Structures Design Engineer

SSPC - Steel Structures Painting Council

TAG - Technical Advisory Group

SDB - Structures Design Bulletin

## **I.5 References**

A. Except where modified in this Manual, conform to the requirements of the specifications, codes, manuals and design requirements referenced in this section.

B. AASHTO Publications

1. The Manual for Bridge Evaluation, 1<sup>st</sup> Edition (2008)
2. LRFD Bridge Design Specifications, 4th Edition (2007) with 2009 Interims
3. LRFD Movable Highway Bridge Design Specifications, 2nd Edition (2007) with 2008 Interims

C. FDOT Publications (latest editions)

1. Plans Preparation Manual, Volume 1 (Topic No.: 625-000-007)
2. Plans Preparation Manual, Volume 2 (Topic No.: 625-000-008)
3. Construction Project Administration Manual (CPAM) (Topic No. 700-000-000)
4. Design Standards with latest Design Standards Modifications (Topic No.: 625-010-003)
5. CADD Production Criteria Handbook

## 6. FDOT Standard Specifications for Road and Bridge Construction

### D. Other Publications

#### 1. AISC Steel Construction Manual - Thirteenth Edition

AREMA Manual for Railway Engineering

### E. Florida Statutes

#### 1. Sections 316.535, 334.044, 334.045, 334.046, and 335.074

## I.6 Coordination

Direct all questions concerning the applicability or requirements of any of the referenced documents to the State Bridge Evaluation Engineer or to the appropriate District Structures Maintenance Engineer or his/her designee.

## I.7 Distribution

One official copy of this Manual will be held by each District Maintenance Office, each District Structures and Facilities Office, each District Structures Design Office, each District Traffic Engineer, the Structures Design Office, the Engineer of Maintenance Operations, the State Bridge Evaluation Engineer, and the Forms and Procedures Office. Additional official holders may be specified by the Office of Maintenance. The Office of Maintenance will maintain a master list to ensure additions and revisions are distributed to all official holders of the manual.

Each office may obtain additional copies of this Manual, but it will be the individual office's responsibility to ensure that these additional manuals are updated.

Interested parties may obtain copies of this Manual from the Forms and Procedures website.

## I.8 Modifications

Modifications may be the result of changes in FDOT specifications, FDOT organization, Federal Highway Administration (FHWA) regulations, and AASHTO requirements.

All revisions and updates will be coordinated with the Forms and Procedures Office prior to distribution to ensure conformance with and incorporation into the Department's Standard Operating System, Procedure No. 025-020-002.

The Manual Review Committee will consist of all District Structures Maintenance Engineers or his/her designee and the State Bridge Evaluation Engineer. The State Bridge Evaluation Engineer shall periodically convene the Manual Review Committee to review the manual and to consider any proposed revisions. The committee shall meet at least quarterly.

Requests for revisions to this Manual shall be submitted in writing to the State Bridge Evaluation Engineer, Florida Department of Transportation, M.S. 52, 605 Suwannee Street, Tallahassee, Florida 32399-0450.

Load Rating Bulletins may be issued by the Office of Maintenance to implement an immediate modification to this Manual.

## **I.9 Training**

None Required

## **I.10 Forms**

Form No. 850-010-06 Load Capacity Information may be accessed from the Department's Forms Library.

### **CI.10**

This form will sunset in the next update of the Manual. In the interim, consultants and Department personnel should use the rating summary tables shown in Appendix A.

**BRIDGE LOAD RATING MANUAL  
TABLE OF CONTENTS**

Table of Contents ..... i

1 Introduction ..... Error! Bookmark not defined.

1.1 Load Rating and Inspection..... 1-1

1.2 Objectives ..... 1-2

1.3 Definitions ..... 1-2

1.4 Quality Assurance Review of Load Ratings ..... 1-3

1.4.1 General Requirements ..... 1-3

1.4.2 Specific Check and Review Required ..... 1-4

1.4.2.1 Computer Programs..... 1-4

1.4.2.2 Checking..... 1-4

1.4.2.3 Review ..... 1-4

1.4.2.4 Quality Assurance Review ..... 1-4

1.4.2.5 Reanalysis ..... 1-5

1.4.2.6 Load Rating File..... 1-5

1.4.2.7 Bridge Management System Data ..... 1-5

1.4.2.8 Quality Control Plan

2 Load Rating Process ..... 2-1

2.1 General ..... 2-1

2.2 Concepts ..... 2-1

2.2.1 New Bridges..... 2-3

    FDOT Figure 2.2.1-1 Flowchart For Load Rating..... 2-5

2.2.2 Existing Bridges ..... 2-6

2.2.3 Widened and Rehabilitated Bridges ..... 2-6

    FDOT Figure 2.2.3-1 Widening / Rehabilitation Load Rating Flow Chart..... 2-10

2.2.4 Temporary bridging

3 Working Responsibilities ..... 3-1

3.1 District Structures Maintenance Office ..... 3-1

3.2 Office of Maintenance ..... 3-3

3.3 State Structures Design Office ..... 3-3

4 Utilization of Consulting Engineer ..... 4-1

4.1 General ..... 4-1

4.2 Controls..... 4-1

4.3 Consultant Qualifications ..... 4-1

5 Data Collection ..... 5-1

5.1	General .....	5-1
5.2	Existing Plans.....	5-1
5.3	Inspection Reports .....	5-1
5.4	Other Records.....	5-2
6	Load Rating Analysis .....	6-1
6.0	Overview of Load Rating Methods and Procedures .....	6-1
	FDOT Table 6.0-1 Acceptable Load Rating Methodologies.....	6-1
	Part A – Load and Resistance Factor Rating .....	6-2
6A.1	Introduction.....	6-2
6A.1.6	Evaluation Methods .....	6-2
6A.1.7	Load and Resistance Factor Rating .....	6-2
6A.1.7.1	Design Load Rating .....	6-2
6A.1.7.2	Legal Load Rating .....	6-3
6A.1.8	Component-Specific Evaluation.....	6-3
6A.1.8.3	Diaphragms .....	6-3
6A.1.8.4	Support for Expansion Joint Devices.....	6-4
6A.1.8.5	Anchorage for Post-Tensioning Tendons .....	6-4
6A.1.8.6	Post Tensioned Concrete Beam Splices within a Span.....	6-5
6A.1.8.7	Post Tensioned Concrete Beam Dapped Hinges within a Span.....	6-5
6A.1.8.8	Bascule Bridges.....	6-6
6A.1.8.9	Gusset Plates on Truss Bridges .....	6-6
6A.2	Loads for Evaluation .....	6-6
6A.2.3	Transient Loads .....	6-6
6A.2.3.1	Vehicular Live Loads (Gravity Loads): LL.....	6-6
6A.3	Structural Analysis .....	6-7
6A.3.1	General.....	6-7
6A.3.2	Approximate Methods of Structural Analysis .....	6-8
6A.3.3	Refined Methods of Analysis .....	6-8
6A.4	Load Rating Procedures .....	6-9
6A.4.2	General Load Rating Equation .....	6-9
6A.4.2.2	Limit States.....	6-9
	FDOT Table 6A.4.2.2-1 Limit States and Load Factors for Load Rating.....	6-10
6A.4.2.3	Condition Factor .....	6-11
6A.4.2.4	System Factor .....	6-11
	FDOT Table 6A.4.2.4-1 General System Factors ( $\phi_s$ ).....	6-11
	FDOT Table 6A.4.2.4-2 System Factors ( $\phi_s$ ) for Post-Tensioned Concrete Beams .....	6-12
	FDOT Table 6A.4.2.4-3 System Factors ( $\phi_s$ ) for Steel Girder Bridges .....	6-12
6A.4.4	Legal Load Ratings.....	6-13
6A.4.4.1	Purpose .....	6-13
	FDOT Figure 6A.4.4.2.1-1 Florida Legal Trucks .....	6-14
	FDOT Figure 6A.4.4.2.1-2 Additional Florida Legal Trucks .....	6-15
6A.4.4.2.3	Generalized Live Load Factors: $\gamma_L$ .....	6-15
6A.4.5	Permit Load Ratings .....	6-16
6A.4.5.1	Background .....	6-16
6A.4.5.2	Purpose .....	6-16

6A.4.5.4.2 Load Factors .....	6-16
6A.4.5.4.2a Routine (Annual) Permits .....	6-16
6A.4.5.5 Dynamic Load Allowance .....	6-17
6A.4.5.8 Adjoining Lane Loading .....	6-17
6A.5 Concrete Structures .....	6-18
6A.5.2 Material .....	6-18
6A.5.4 Limit States .....	6-18
6A.5.4.1 Design-Load Rating .....	6-18
FDOT Table 6A.5.4.1-1 Stress Limits for Prestressed Concrete Bridges .....	6-19
6A.5.4.2 Legal Load Rating and Permit Load Rating .....	6-20
6A.5.4.2.2a Legal Load Rating .....	6-20
6A.5.4.2.2b Permit Load Rating .....	6-20
6A.5.7 Minimum Reinforcement .....	6-20
6A.5.9 Evaluation for Shear .....	6-20
6A.5.12 Temperature, Creep and Shrinkage Effects .....	6-21
6A.5.13 Rating of Segmental Concrete Bridges .....	6-21
6A.5.13.2 General Rating Requirements .....	6-21
6A.6 Steel Structures .....	6-22
6A.6.4 Limit States .....	6-22
6A.6.4.1 Design-Load Rating .....	6-22
FDOT Table 6A.6.4.1-1 Stress Limits for Prestressed Concrete Decks on Steel Bridges .....	6-24
6A.6.13 Fracture-Critical Members (FCMs) .....	6-24
6A.6.14 Double-Leaf Bascule with Span Locks .....	6-24
Appendix A6A Load and Resistance Factors Rating Flow Chart .....	6-25
Appendix B6A Limit States and Load Factors for Load Rating .....	6-25
Appendix D6A AASHTO Legal Loads .....	6-25
Appendix J6A Rating of Segmental Concrete Box Girder Bridges Step-By-Step Supplement .....	6-25
J6A.1 Load Factors and Load Combinations .....	6-25
J6A.2 Design Load Rating – Inventory .....	6-25
J6A.3 Design Load Rating – Operating .....	6-27
J6A.4 Legal Load Rating .....	6-28
J6A.5 Permit Load Rating .....	6-28
J6A.6 Capacity – Strength Limit State .....	6-29
J6A.7 Allowable Stress Limits – Service Limit State .....	6-29
J6A7.1 Longitudinal Tension in Joints .....	6-30
J6A.7.2 Transverse Tensile Stress .....	6-30
J6A.7.3 Principal Tensile Stress – Service Limit State .....	6-30
J6A.8 Local Details .....	6-31
Part B – Allowable Stress Rating and Load Factor Rating .....	6-32
6B.1 General .....	6-32
6B.1.4 Application of Standard Design Specifications .....	6-32
6B.6 Nominal Capacity .....	6-32
6B.6.3 Load Factor Method .....	6-32
6B.6.3.3 Prestressed Concrete .....	6-32
6B.7 Loadings .....	6-32

---

6B.7.2.2 Truck Loads.....	6-32
7 Posting of Bridges and Post Avoidance .....	7-1
7.1 General .....	7-1
7.2 Posting Avoidance .....	7-1
7.2.1 –Dynamic Load Allowance (IM) for Improved Surface Conditions (Variance) ..	7-2
7.2.2 Approximate and Refined Methods of Analysis (Variance) .....	7-2
7.2.3 Shear Capacity by AASHTO LRFD for Segmental Box Girder Bridges (Variance).....	7-3
7.2.4 Existing Bridge Inventory Before January 2005 (Variance).....	7-3
7.2.5 Principal Tension – Segmental Concrete Bridges (Box Girders) (Variance) ..	7-3
7.2.6 Stiffness of Traffic Barrier (Exception).....	7-4
7.2.7 Segmental Concrete Box Girder – Longitudinal Tension in Epoxy Joints (Exception) .....	7-4
7.2.8 Transverse Tensile Stress Limit in Top Slab (Exception).....	7-5
7.2.9 Concrete Box Girder – Principal Tensile Stress (Exception) .....	7-5
7.2.10 Reduced Structural (DC) Dead Load (Exception) .....	7-6
7.3 Procedures for Posting of Weight Restrictions on Department Maintained Structures .....	7-7
7.4 Procedures for Posting Weight Restrictions on Local Government Structures .	7-10
8 Load Testing of Bridges .....	8-1
8.1 General .....	8-1
C8.1 .....	8-1
8.2 Load Test Candidate .....	8-2
8.3 Load Test Reports.....	8-3
9 Permitting Operations .....	9-1
10 Summary of Ratings .....	10-1
Appendix A - LOAD RATING SUMMARY TABLES .....	A-1

# 1 INTRODUCTION

## 1.1 Load Rating and Inspection

While the *Bridge Load Rating Manual* is a separate Manual, the load rating process is a component of the inspection process and consists of determining the safe load carrying capacity of structures, determining if specific legal or overweight vehicles can safely cross the structure and determining if a structure needs to be restricted and the level of posting required. During and as a result of each inspection, the Districts will determine if the load rating on file reflects the current capacity of the bridge and will update the rating and Pontis if necessary. The bridge management system consists of the following volumes:

- A. Volume 1 - **Bridge and Other Structures Inspection and Reporting Procedures Manual**; (Topic No. 850-010-030). Specifically defines standards for inspection and reporting practices.
- B. Volume 2 - **Bridge Maintenance Repair Methods Handbook**; defines standard maintenance and repair details including repair equipment, material and manpower.
- C. Volume 3 - **Bridge Underwater Operations Manual**; (Topic No. 850-010-011) defines the procedures and safety requirements for diving operations to perform underwater bridge inspections. (Note: This manual is currently referred to as the Dive Manual.)
- D. Volume 4 - **Moveable Bridge Operations**; (Topic No. 850-010-032) defines the organization, responsibilities and functions involved in bridge inspection, maintenance and operations.

## 1.2 Objectives

The objectives of this Manual are to codify the procedures and to detail the concepts for the load rating, posting and permitting process. Specific examples of load rating are not included.

## 1.3 Definitions

All Engineering decisions shall be documented.

- A. Decision based on Engineering Judgment - Decisions made by a registered Professional Engineer based on knowledge and experience of applied engineering principles, recognized formulae, computer programs, or load tests. Such judgment should be used to evaluate the validity of the initial input and the final output.
- B. Governing Component - That component of a structure with the least live load carrying capacity.
- C. Inventory Rating or "Design" Load Rating - The rating which represents the load level which can safely utilize an existing structure for an indefinite period of time.
- D. Live Load Distribution Factor - The fraction of a rating truck wheel line or lane load assumed to be carried by a structural component.
- E. Load Rating - The process of determining the live load capacity of a structure based on its current condition through analysis and Engineering Judgment. Load tests may be used as load rating provided that all the trucks required to be evaluated for a standard load rating are also evaluated based upon the test results.
- F. Operating Rating - The rating which represents the absolute maximum

permissible load level to which the structure may be subjected.

- G. Rating Factor - The ratio of the available Live Load Moment or Shear Capacity to the Moment or Shear produced by the load being investigated.
- H. Redundant - A structure for which multiple load paths exist, where if one element fails, alternate load paths will allow the load to be redistributed. Redundancy can also be Structural or Internal.
- I. Marginal Rating - For bridges Designed for HS 20 or HS 25 loading, an HS 20 Operating Rating less than 60 Tons. For Bridges Designed for HL 93, FL 120 Rating Factor less than 1.0.
- J. Posting Avoidance Techniques – Applying engineering judgment to a load rating by modifying the specification defined procedures through use of Variances and Exceptions (as defined in the *PPM*). See Section 7 for Posting Avoidance details and requirements.

## **1.4 Quality Assurance Review of Load Ratings**

### **1.4.1 General Requirements**

The mission of the department is to provide a safe transportation system that ensures the mobility of people and goods. The load rating process recognizes a balance between safety and economics. Both in-house and consultants' load rating results should be checked for accuracy as part of the quality control process. Specifically when the rating for a new bridge is marginal, the rating should be reviewed to determine the reason(s). If the consultant performs the rating, he or she should provide in writing the reason(s) why the rating is marginal. The following

reasons are the most commonly recognized reasons for marginal ratings:

- A. The bridge has not been designed to its intended level
- B. Modifications were made during the construction that changed the bridge design level
- C. The load rating is inaccurate

#### **1.4.2 Specific Check and Review Required**

##### **1.4.2.1 Computer Programs**

Whenever possible, the load rater should perform long hand checks of a portion of the computer analysis to satisfy the load rater that the computer program is accurate. It is of utmost importance that the load rater understands when computer results are reasonable. Blind faith in any computer program should be avoided.

##### **1.4.2.2 Checking**

An independent check of the analysis shall be performed. When computer programs are used, the checker should verify all input data, verify that the summary of load capacity information accurately reflects the analysis, and be satisfied with the accuracy and suitability of the computer program.

##### **1.4.2.3 Review**

The analysis must be performed under the supervision of a Professional Engineer. If the load rater is not a Professional Engineer, then the Professional Engineer in charge must review the work for accuracy and completeness

##### **1.4.2.4 Quality Assurance Review**

Each year, the Office of Maintenance will perform quality assurance review of the load rating performance for each District. The current schedule, monitoring plan and critical requirements and compliance

indicators are included in the Quality Assurance Plan available on the Office of Maintenance website.

#### **1.4.2.5 Reanalysis**

When the condition of a structure changes a reanalysis of the structure may be required. Conditions that may require reanalysis are; structural deterioration, damage due to vessel or vehicular hits or specification changes. Every bridge inspection report and accident report should be reviewed by a person knowledgeable in load rating concepts to determine if reanalysis is required. All bridge inspection reports are to be reviewed by the load rating section. The District Quality Control Plan shall include a method to document that this review is performed for every routine bridge inspection event.

#### **1.4.2.6 Load Rating File**

Computer input and output files, hand calculations, field measurements, catalogs and other pertinent information, used in performing load rating, shall be stored in the load rating file. This will provide easy access for reviewing or revising the load rating.

#### **1.4.2.7 Bridge Management System Data**

The accuracy of this data is vital to the operation of the Road Use Permits Office. Therefore, the load rating section will obtain an output of the Comprehensive Inventory Data Report (CIDR) after the inspection report has been reviewed. If no reanalysis is required, the load rating section will verify the load rating data for Items 67 and 48. After reanalysis, the load rating section will either update the database or provide the person responsible for updating the database with the proper values and back check the data

after the database has been updated.

#### **1.4.2.8 Quality Control Plan**

The District shall have a quality control plan in place including quality assurance review of consultants if consultants perform the Quality Control of load ratings. The plan shall include clear recommendation for determining if a bridge load rating needs to be updated during each inspection cycle. The maximum time allowed to update the rating past the date the inspection report is signed is 60 days for simple bridges and 90 days for more complex bridges . Exception to this requirement should be made in writing to the State Bridge Evaluation Engineer no later than 30 Days after the inspection report is signed. The request for exception shall clearly state why the bridge load rating cannot be timely updated. The Pontis Database should be updated within 14 days of the time the load rating is accepted by the Department. The Department will notify the agencies within 1 week after a need for posting is identified.

## 2 LOAD RATING PROCESS

### 2.1 General

Florida Administrative Code 14-15.002, ***Manual of Uniform Standards for Design, Construction, and Maintenance for Streets and Highways*** (Commonly known as the "***Florida Greenbook***") requires load rating for all bridges in Florida.

The specifications governing this work is the current version of the ***MBE***, published by AASHTO and as modified by this ***Manual***. The District Maintenance Engineer and appropriate staff are responsible to ensure that every bridge structure within their jurisdiction is properly load rated.

### 2.2 Concepts

The following concepts are to be applied to the load rating process:

- A. Substructures generally do not control the load rating. However, after the superstructure has been load rated, the load rater shall determine if the substructure can carry an equivalent or greater load than the superstructure. If not, the substructure will be load rated and the load rating adjusted. A complete or partial analysis of the substructure is not required if, in the engineering judgment of the load rater, the substructure has equivalent or greater capacity than the superstructure. The load rater must be aware that short span bridges capacity based upon superstructure evaluation may allow vehicles with weights exceeding 500,000 lbs to cross generating significant impact on the substructure.
- B. Reinforced concrete bridge decks on redundant, multi-girder bridges will not normally be rated unless damage,

### C2.2

Historical commentary. In 1993 the FHWA requested that all bridges on the National Highway System be load rated using the load factor method. After discussion with the FHWA the department agreed to load rate all functionally obsolete and structurally deficient bridges on the National Highway System with the load factor method. This agreement does not prevent new bridges on the National Highway System and reanalysis of existing bridges on the National Highway System from being performed with the load resistance factor method.

deterioration, or other reasons merit this analysis. All other bridge deck systems shall be rated.

- C. Utilizing engineering judgment, all superstructure spans and components of the span shall be load rated for both moment and shear until the governing component is established. For example, a two girder superstructure system with floor beams and stringers would require the rating of stringers, floor beams and girders to establish the governing component. If the engineer, using engineering judgment determines that certain components will not control the rating, then a full analysis of the non-controlling elements is not required. Typically, certain components such as barriers or joints are not load rated.
- D. For most bridges, the governing rating shall be the lesser of the shear capacity or moment capacity of the critical component. For more complex structures, other stresses such as principal web tension in concrete post-tensioned segmental bridges at service limit states will be investigated.
- E. Some composite prestressed concrete girder bridges were designed with the deck continuous over the supports in order to eliminate transverse deck joints. The girders of these bridges were not made continuous over the support. Bridges meeting this description shall be load rated as simple spans.
- F. The AASHTO supported software VIRTIS is the preferred load rating program to load rate all bridges that meet the bridge configurations and capabilities of the program. For additional comments, see Section 6A.1.6.

- G. When consultants perform load ratings, they will follow the requirements of this **Manual** and the current version of the **MBE**. The district load rating staff will review the consultant's load ratings and perform spot checks to confirm accuracy of the consultant's work. Consultant load ratings shall be signed and sealed by a professional engineer. The consultant shall have quality control procedures in place to assure the accuracy and completeness of the load ratings.

### 2.2.1 New Bridges

- A. When load rating structures, perform a **LRFR** load rating analysis as defined in the **MBE** and as modified by this **Manual**.
- B. For new bridges the Engineer of Record shall load rate the bridge(s) and submit the calculations and Load Rating Summary Tables for the entire structure with the 90% plan submittal for the project.
- C. The bridge owner shall perform a load rating for the as-built changes (if any) and provide the Department with the completed Bridge Load Rating Summary Table within 90 or 180 days of opening for on-system or off-system bridges, respectively. The bridge owner should consider requiring the engineer of record to perform the load rating.
- D. Load rate bridge-size culvert (see definition in **PPM** Volume 1, Chapter 33,) in accordance with this **Manual** and **SDG** 3.15. Calculations must be signed and sealed by a professional engineer currently approved to perform Minor Bridge Design under Rule 14-75 of the Florida Administrative Code.

### C2.2.1

Load Rating may control the design in some cases.

- E. Cast-in-place culvert load ratings must be performed by the licensed professional engineer designer. Show the load rating summary in the Contract Plans. Precast culverts must be load rated by the Contractor's Engineer of Record (see definition in the Construction Specifications Section 102) and the load rating shown on the approved shop drawings, unless otherwise provided on the Design Standards, Index No. 292.
- F. See Figure 2.2.1-1 for load rating flowchart.

FDOT Figure 2.2.1-1 Flowchart For Load Rating

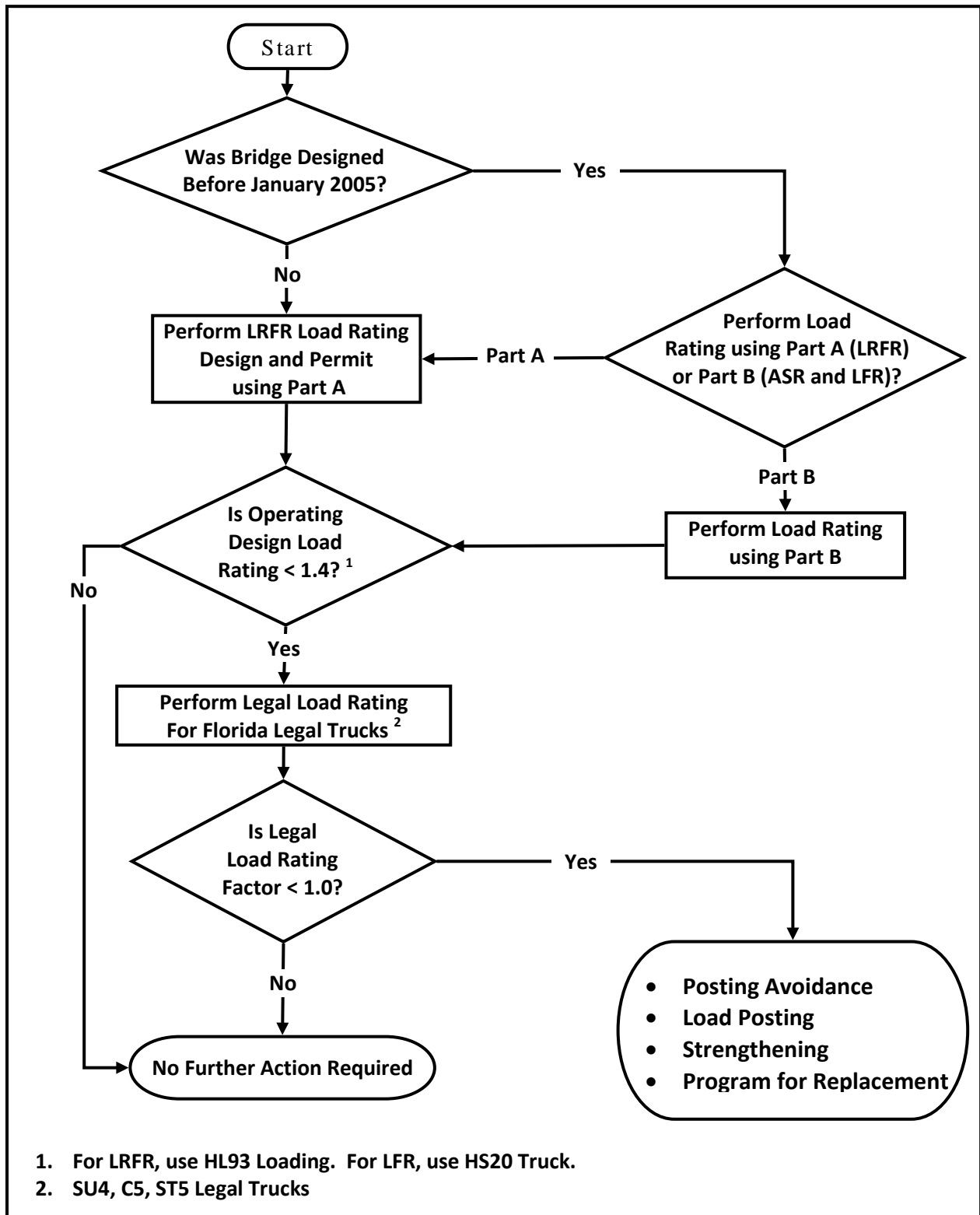

### 2.2.2 Existing Bridges

- A. The **LRFR** method is the preferred method of analysis. Load Factor Rating (**LFR**) may be used for existing structures not designed using the **LRFD** method.
- B. Deck panel systems which are in poor condition (exhibiting either transverse or longitudinal spalling), shall have the live load distribution factors established as if the deck slabs act as simple spans between girders.
- C. Load ratings for existing bridges must be performed using the load factor, load test or the load and resistance factor rating methods. An existing load rating performed with load factor does not have to be reanalyzed with newer methods.
- D. When an existing bridge with a working stress load rating requires reanalysis that structure should be reanalyzed with load factor or load resistance factor rating methods.
- E. See Figure 2.2.1-1 for load rating flowchart.
- F. Posting avoidance strategies through the use of variances and exceptions are given in Section 7.

### 2.2.3 Widened and Rehabilitated Bridges

- A. Prior to developing the scope-of-work for bridge widening and/or rehabilitation projects, the Department or their consultant will review the inspection report and the existing load rating to determine the suitability of the bridge project.
- B. If the existing load rating is inaccurate or was performed using an older method (e.g. Allowable Stress or Load Factor), perform a new load rating of

### C2.2.2

Unless there is a change in condition of the bridge, an existing load rating using allowable stress method or load factor design is not required to be load rated with **LRFR**.

the existing bridge in accordance with this **Manual**. Design all bridge widening or rehabilitation projects in accordance with **SDG 7.3**. If the bridge to be widened/rehabilitated does not have a design load rating (inventory, **LFR** and **LRFR**) and a FL 120 permit load rating (**LRFR** only), greater than or equal to 1.0, regardless of the specification used, replacement or strengthening is required unless a Design Variation is approved.

- C. If the widening or rehabilitation of a bridge does not produce a **LRFR (Part A)** design inventory rating factor and a FL 120 permit rating factor greater than or equal to 1.0, calculate and report the appropriate rating factor using **LRFR (Part B)** and send a copy of the Load Rating Summary Table to the State Structures Design Office. If the load rating at inventory level using **LRFR (Part B)** yield an inventory rating factor of less than 1.0, a revised load rating using one of the additional procedures in C.1, C.2, C.3, or C.4 may be performed to obtain a satisfactory inventory rating. Submit a Design Variation for use of the additional methods of analysis or for an inventory load rating factor of less than 1.00 to the State Structures Design Engineer.

1. **Approximate Method of Analysis:** When using an approximate method of structural analysis defined in the specifications along with the specification defined live load distribution factors, a rating factor of 0.95 may be rounded up to 1.0.
2. **Refined Method of Analysis:** Refined methods of structural analyses, as discussed in Section 6A.3.3, may be performed in order

to establish an enhanced live load distribution and improved load rating. For continuous post-tensioned concrete bridges, a more sophisticated, time-dependent construction analysis is required to determine overall longitudinal effects from permanent loads (e.g. BD 2 analysis).

3. **Shear Capacity - Segmental Concrete Box Girder - Crack Angle *LRFD* (*LRFD* 5.8.6):** To calculate a crack angle more accurately than the assumed 45 degree angle used in the specifications, use the procedure found in Appendix B of "Volume 10A Load Rating Post-Tensioned Concrete Segmental Bridges" (dated Oct. 8, 2004) found on the Structures Design Office website.
  4. **Service Limit State:** If the load carrying capacity as determined by Service III Limit State yields a rating factor less than 1.0 and the current bridge inspection is showing no signs of either shear or flexural cracking, the capacity may be established using Strength Limit State. Submit a Design Variation for an inventory load rating factor of less than 1.00 to the State Structures Design Engineer.
- D. See Figure 2.2.3-1 for a flow chart of the widening/rehabilitation decision making process.
- E. The final load rating for a bridge widening must use a consistent load rating method for both the existing and widened bridge.
- F. The Engineer of Record shall load rate the bridge(s) and submit the calculations and Load Rating Summary Tables for the entire

structure with the 90% plan submittal for the project.

- G. The bridge owner shall perform a load rating for the as-built changes (if any) and provide the Department with the completed Bridge Load Rating Summary Table within 90 or 180 days of opening for on-system or off-system bridges, respectively. The bridge owner should consider requiring the engineer of record to perform the load rating.
- H. Lengthening of bridge culverts shall be load rated as specified in Section 2.2.1.D and 2.2.1.E.

#### **2.2.4 Temporary bridging:**

When temporary bridging (Acrow, Mabey, etc) is opened to traffic at a site, the District Structures Maintenance Engineer or his/her designee shall ensure that posted signs are installed to restrict permitted overweight vehicle. The signs should state "Legal Weight Only)

FDOT Figure 2.2.3-1 Widening / Rehabilitation Load Rating Flow Chart

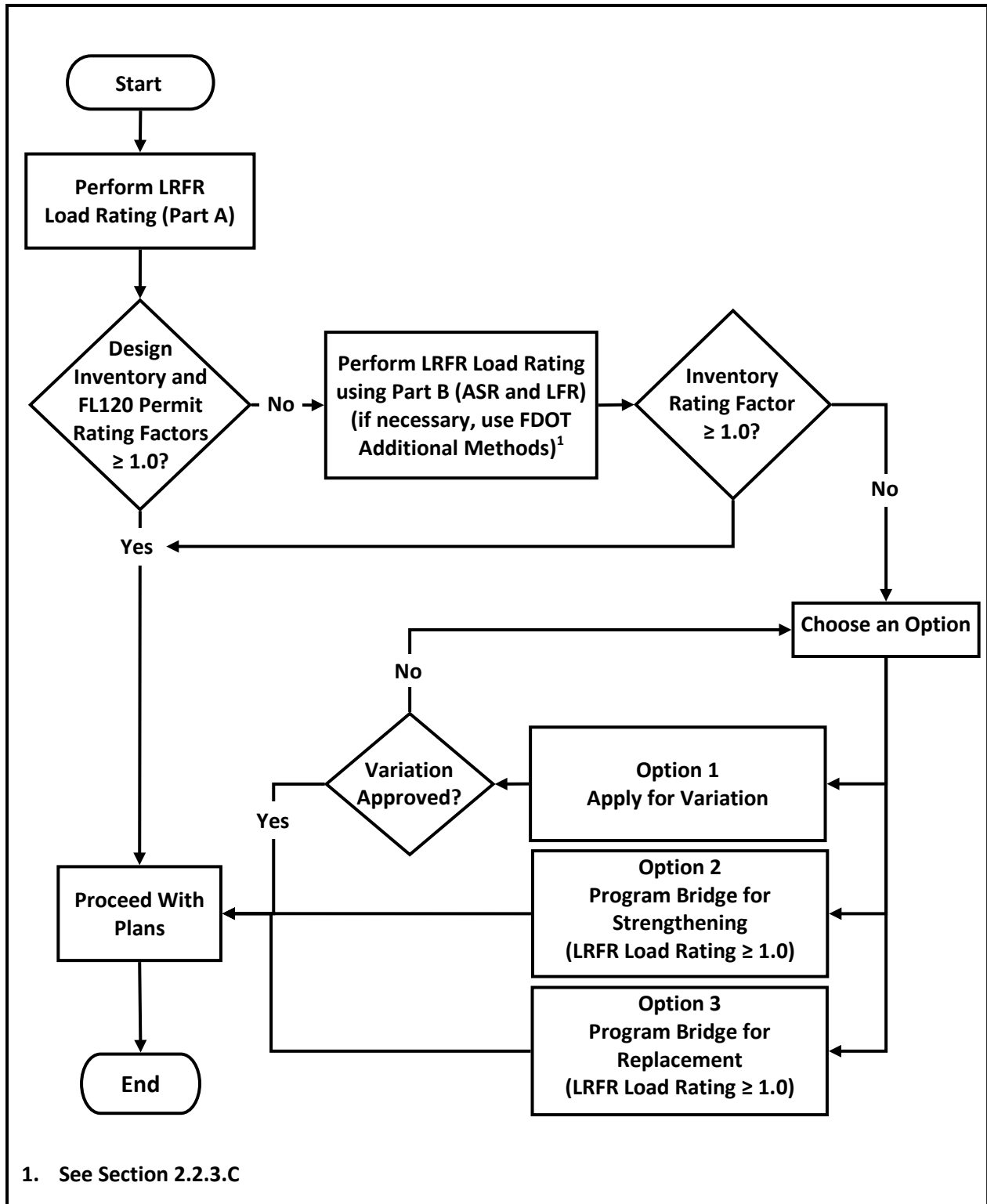

### **3 WORKING RESPONSIBILITIES**

#### **3.1 District Structures Maintenance Office**

The responsibilities of the District Structures Maintenance office are:

- A. Perform load ratings.
- B. Administer consultant contracts performing load ratings. Review load ratings prepared by consultants for new and existing bridges.
- C. Enter results of load ratings into the database and Section D (Load Rating) of the Bridge Record. Final load ratings should be entered into the database within 90 days of final Acceptance by Construction for State bridges and 180 days for Local Government bridges. All Districts shall obtain the initial design load rating performed at 90% of the Design phase from the Engineer of Record and enter the data in Pontis within 14 days from acceptance by construction. If no initial Design Load rating is available, or if the District deems the load rating not to be applicable to the current condition, the bridge will be restricted to legal load traffic and no permitted vehicles will be permitted to cross. In case the District recommends that overweight vehicles cross a bridge for which no load rating is provided yet, the District shall contact the EOR and provide to the Office of Maintenance and the State Bridge Evaluation Engineer a written notification of the temporary load rating recommendations. In this case for bridges load rated using the **LRFR** method, FL120 rating will be provided. For bridges rated with any other method, a temporary HS20 rating will be provided at the operating level.

When changing conditions require a new load rating, the new load rating data should be entered into the database within 90 days for state bridges and 180 days for local government bridges. District should make every attempt to incorporate the load rating performed at the end of the design phase into the Bridge Database (Pontis) as soon as the bridge is opened to traffic to enhance mobility.

- D. Recommend bridges to be load tested to the Office of Maintenance for coordination and prioritization.
- E. For State bridges, immediately inform in writing the Office of Maintenance and the State Bridge Evaluation Engineer of any decrease in load rating capacity (HS20 operating rating level for all rating methods excluding **LRFR**, and FL120 for **LRFR**) exceeding 5% of the original value, reductions or increases of the safe load carrying capacity of structures immediately. Update the capacity information in the bridge database (Pontis) immediately.
- F. Initiate requests for load postings and removal of load postings.
- G. Maintain bridge design plans, as-built plans and shop drawing inventory.
- H. Review bridge inspection reports to determine when reanalysis is required.
- I. Once a year, in a format acceptable to the Office of Maintenance, update and maintain the district county bridge maps and provide copies to the Office of Maintenance.
- J. Provides information to the Road Use Permit Office to determine potential conflicts of a temporary nature to moving oversized/overweight vehicles (see Section 9).

### 3.2 Office of Maintenance

The responsibilities of the Office of Maintenance are:

- A. Quality assurance review.
- B. Establish procedures.
- C. Training.
- D. Assist Districts and Road Use Permits Office when requested.
- E. Act on software computer program malfunctions for Virtis.
- F. Inform districts of new procedures and concerns.
- G. Review load posting and load posting removal requests.

### 3.3 State Structures Design Office

The responsibilities of the State Structures Design Office are:

- A. Assist the Office of Maintenance in resolving inconsistencies between the **Structures Manual** and this Manual.
- B. Propose analysis programs.
- C. Address software malfunctions in software approved by the State Structures Design Office.
- D. Quality Assurance review based on new proposed software or methods.

## **4 UTILIZATION OF CONSULTING ENGINEER**

### **4.1 General**

Consultants may be used for load rating state owned bridges when in-house resources are lacking. Consultants are used to load rate local agency bridges as part of the local government bridge inspection contracts. If conditions are found during the consultant's inspection that would change the load rating of the structure, the Department's project manager may direct the consultant to determine a new load rating for the structure based on the results of the inspection.

### **4.2 Controls**

Consultants shall load rate structures in accordance with this Manual, the current version of the **MBE**, and other documents included and referred to in the contract. Those documents should be reviewed by the consultant to determine if any questions arise from using those manuals and procedures. Questions should be directed in writing to both the Office of Maintenance, State Bridge Evaluation Engineer and the Structures Design Office.

### **4.3 Consultant Qualifications**

For the load rating of routine structures the consultant must have experience in the design or load rating of bridges. For the load rating of complex structures, the consultant's engineer performing the load rating must have experience in designing that type of structure. Examples of complex structures are segmental concrete bridges, post-tensioned bridges, curved steel box girder bridges, curved steel girder bridges and trusses. If the consultant changes the individual or individuals performing the load rating of a

complex structure, the new individual must be approved by the Department's project manager.

## **5 DATA COLLECTION**

### **5.1 General**

The first step is the collection of relevant existing data required to perform the load rating.

The following hierarchy of data will be used for load rating:

1. As-built plans to be supplemented with field measurements and bridge inspection reports
2. In the absence of as-built plans, design plans supplemented with field measurements and bridge inspection reports
3. In the absence of plans, field measurements and bridge inspection reports will be used.

### **5.2 Existing Plans**

Existing plans are used to determine loads, bridge geometry, section and material properties. Design plans (as-bid plans) are created by the designer and used as a contract document for bidding the job. Certain structures (generally flat slab bridges and culverts) are built from standard drawings. These standard drawings have been changed and revised over time. The specific standard drawings used for construction are generally identified in the roadway plans for the project under which the bridge was built. Construction record plans (as-built plans) are contract design plans which have been modified to reflect changes made during construction. Shop drawings are also useful sources of information about the bridge. Plans may not exist for some bridges. In these cases field measurements will be required.

### **5.3 Inspection Reports**

Inspection reports must be reviewed prior to load rating to determine if there is

deterioration or other damage present that may change the carrying capacity of the structure and whether or not the load rating in the file is valid.

#### **5.4 Other Records**

Other appropriate bridge history records, such as repair or rehabilitation plans, should be reviewed to determine their impact on the load carrying capacity of the structure.

## 6 LOAD RATING ANALYSIS

The chapter numbers in this section are organized using the same chapter numbers of the **MBE** to quickly coordinate and associate this **Manual's** criteria with that of the **MBE**.

### 6.0 Overview of Load Rating Methods and Procedures

The load rating of existing structures shall be in accordance with Table 6.0-1. The order of preference in rating methodologies is:

1. load and resistance factor rating (**LRFR**)
2. load factor rating (**LFR**)
3. allowable stress rating (**ASR**)

### C6.0

*Add the following:*

In 1993 an agreement was reached between the FHWA and the FDOT concerning the use of allowable stress method for load rating bridges. In summary, the agreement states allowable stress rating is not permitted for bridges on the National Highway System if the bridge is either structurally deficient or functionally obsolete.

**FDOT Table 6.0-1 Acceptable Load Rating Methodologies**

DESIGN METHODOLOGY	LOAD-RATING METHODOLOGY <sup>1</sup>		
	Allowable Stress Rating-ASR (Part B)	Load Factor Rating LFR (Part B)	Load & Resistance Factor Rating-LRFR (Part A)
Allowable Stress Design ( <b>ASD</b> )	√ <sup>2</sup>	√	√
Load Factor Design ( <b>LFD</b> )		√	√
Load & Resistance Factor Design ( <b>LRFD</b> )			√ <sup>3</sup>

1. The analysis shall include reference to the dated Structures Manual.
2. Allowable stress rating is not permitted for bridges on the National Highway System if the bridge is either structurally deficient or functionally obsolete.
3. Bridges designed using the **LRFD** methodology before January 7, 2005 may be load rated using either the **LFR** or **LRFR** methodologies. For **LRFD** designs (January 7, 2005 and after), the Department will not allow the use of an alternative load rating methodology (Part B) or posting avoidance techniques, with the exception of curved steel bridges designed using the **LFD** method.

## Part A – Load and Resistance Factor Rating

### 6A.1 Introduction

#### 6A.1.6 Evaluation Methods

*Add the following:*

The FDOT preferred load rating program is VIRTIS. VIRTIS should be used if the program is capable of performing the load rating analysis of the bridge. For **LRFR** load ratings Conspan and Smart Bridge are also available.

#### 6A.1.7 Load and Resistance Factor Rating

*Delete the last sentence and add the following:*

The routine FDOT rating process is shown in Section 2.2. Rate bridges designed January 2005 and after using **LRFR (Part A)**. For bridges other than prestressed concrete segmental box girders, designed before January 2005, use **LRFR (Part B)** for rating. For bridges designed using the **LFD** methodology before January 2005, **LRFR (Part A)** may be used as an alternative.

*Replace Figure 6-1, Flowchart for Load Rating, with FDOT Figure 2.2.3-1.*

##### 6A.1.7.1 Design Load Rating

*Replace the 3rd sentence of the 1<sup>st</sup> paragraph with the following:*

Under this check, bridges are screened for both the strength and service limit states.

#### C6A.1.7

*Add the following:*

The rating process of AASHTO **LRFR** suggests that each permit vehicle be evaluated individually. Such is not the case with FDOT or with most other States. Traditionally, annual blanket permits were issued based upon a comparison of force effects of the permit vehicle in question to that of the HS20 operating rating. To continue the practice of having information available to easily judge permit applications, FDOT's rating process includes an FL120 permit load rating as part of the routine rating of bridges. Single-trip permit vehicles will be evaluated outside of the routine FDOT rating process.

Since **LRFR (Part B)** does not specifically address prestressed concrete segmental box girders, perform all rating analysis for this bridge type, using **LRFR (Part A)** procedures. For this bridge type, a minimum acceptable rating factor of 1.0 is required for all legal loads and the FL120 Permit load.

*Delete the 4th and 5th sentences of the 1st paragraph.*

*Replace the 2nd sentence of the second paragraph with the following:*

Bridges that have a design load rating factor equal to or greater than 1.4 at the operating level will have satisfactory load rating for all three Florida legal loads.

#### **6A.1.7.2 Legal Load Rating**

*Replace the 3rd sentence of the 1st paragraph with the following:*

Using this check, bridges are screened for both the strength and service limit states as noted in Table 6.0-1.

*Delete the 4th sentence of the 1st paragraph.*

#### **6A.1.8 Component-Specific Evaluation**

*Add the following:*

Bridges may contain local details that must be appropriately designed to carry local loads or distribute forces to the main bridge components (beams). Although forces in these details can vary as a function of the applied live loads (with the exception of in-span beam splices), it is recommended that they not be included in the load rating. Rather, the capacities of such details should be checked only for critical loads or ratings and then only if there is evidence of distress (e.g. cracks).

##### **6A.1.8.3 Diaphragms**

The main purpose of transverse diaphragms is to provide lateral stability to girders during construction and wind loading.

Transverse diaphragms themselves need not be analyzed as part of a routine load rating. Only if there is evidence of distress (e.g. efflorescence, rust stains or buckling), or at the discretion of the engineer, should it be necessary to more

#### **C6A.1.8**

*Add the following:*

Important local details in concrete bridges include diaphragms and details, such as corbels, that support expansion joint devices and anchorages for post-tensioning tendons. The behavior of these details and the forces to which they are subjected may be determined by appropriate models or hand calculations. Analysis methods and design procedures are available in **LRFD** (e.g. strut and tie analysis).

closely consider the forces and stresses in a diaphragm.

The stiffness of any transverse diaphragms should be included, if significant and appropriate, in any finite element analysis program used to establish Live Load Distribution Factors.

#### **6A.1.8.4 Support for Expansion Joint Devices**

Expansion joint devices are usually contained in a recess formed in the top of the end of the top slab and transverse diaphragm. Occasionally, depending upon the need to accommodate other details, such as drainage systems, this may involve a corbel - usually as a contiguous part of the expansion joint diaphragm. It is not necessary to analyze such a detail for routine load rating. Only if there is evidence of distress (e.g. cracks, efflorescence or rust stains), or at the discretion of the engineer, should it be necessary to more closely consider the forces and stresses in such a detail.

#### **6A.1.8.5 Anchorages for Post-Tensioning Tendons**

Anchorages are normally contained in a widened portion of the web at the ends of a beam. It is not necessary to analyze anchorage details for routine load rating. Only if there is evidence of distress (e.g. cracks, efflorescence or rust stains) should it be necessary to more closely consider the forces and stresses in such a detail itself.

Changes in the gross section properties at anchor block zones should be properly accounted for in any finite element analysis program used to establish principal tension/bursting.

#### **6A.1.8.6 Post Tensioned Concrete Beam Splices within a Span**

Beam splices within a span are frequently used to connect portions of continuous girders. Such splices usually require reinforcing bars projecting from the ends of the precast beams and into a reinforced, cast-in-place transverse diaphragm. Longitudinal post-tensioning ducts are connected and tendons pass through the splice.

Beam splices are typically near inflection points; consequently, live load effects may induce longitudinal tensile stress in the top or bottom. Therefore, the longitudinal tendons are approximately concentric, i.e. at mid-depth of the composite section. It is necessary to check longitudinal flexure and shear effects at in-span beam splices.

#### **6A.1.8.7 Post Tensioned Concrete Beam Dapped Hinges within a Span**

Dapped hinges are rarely used in beam bridges in Florida. Forces acting through dapped hinges within a span should be calculated for statically determinate structures or be determined as a part of the time-dependent construction analysis for indeterminate structures. Maximum live load reactions should also be calculated. Once all reaction forces are known, local analyses should be performed to develop the hinge forces into the main beam components using suitable strut-and-tie techniques. An alternate approach would be to develop three-dimensional finite element models to analyze the flow of forces.

**6A.1.8.8 Bascule Bridges**

Use the appropriate FDOT and *LRFR* system factors. Load rate the bridge for Design Inventory, Design Operating, and the FL120 Permit vehicle assuming the span locks are engaged (driven) to transmit live load to the opposite leaf. In addition, for the Strength I Design Operating Rating, load rate the bridge assuming the span locks are not engaged to transmit live load to the opposite leaf. For both cases, assume the live load to be on the tip side (in front) of the trunnion.

Report the load ratings along with the span lock assumptions. Contact the District Structures Maintenance Engineer for directions on reporting the controlling load case and assumptions. Also load rate the span locks using the impact factors given in SDG 8.5.

**6A.1.8.9 Gusset Plates on Truss Bridges**

When evaluating new and existing truss bridges with gusset plates, follow FHWA Technical Advisory T 5140.29 "Load-carrying Capacity Considerations of Gusset Plates in Non-load-path-redundant Steel Truss Bridges."

**6A.2 Loads for Evaluation****6A.2.3 Transient Loads****6A.2.3.1 Vehicular Live Loads (Gravity Loads): LL**

*Replace the vehicles given after Legal Loads: with the following:*

Florida Legal Loads (SU4, C5, and ST5, see 6A.4.4.2.1 for vehicle configurations).

Florida Legal Loads (SU2, SU3, C3, and C4, see 6A.4.4.2.1 for vehicle configurations).

*Replace the vehicle given after Permit Loads: with the following:*

**C6A.1.8.8**

Requiring a Strength I Design Operating load rating with the span locks removed provides a value that can be used to assess a worst case span lock condition with regard to the operation of the bridge.

**C6A.2.3.1**

*Add the following:*

For simple span bridges, see figure C6-4 for a comparison of legal loads and HL-93.

Florida Permit Load (FL120, see 6A.4.5.4.2.1 for vehicle configurations). For new bridges the minimum rating factor for the FL120 is 1.0.

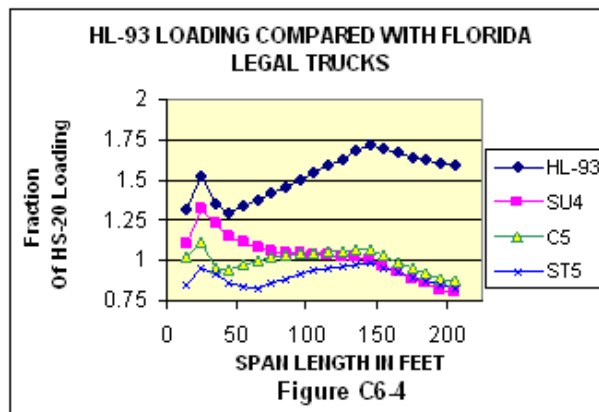

### 6A.3 Structural Analysis

*Add the following:*

Transverse and longitudinal ratings shall be reported for post-tensioned concrete segmental bridges. All bridge decks designed with transverse prestressing require transverse ratings. For all other bridges, only longitudinal ratings are typically required.

#### 6A.3.1 General

*Add the following:*

The level of analysis chosen is a trade off between sophistication of analysis and required work effort. The simpler methods are chosen as a first choice due to the need to analyze many structures with limited resources. When this analysis yields satisfactory results, there is no need to perform a more sophisticated analysis. Satisfactory results would be the establishment of a safe load carrying capacity that does not require posting the structures and does not unduly restrict the flow of permitted overweight trucks. A more sophisticated analysis is justified to avoid posting the bridge or to ease restrictions on the flow of permitted overweight trucks.

### 6A.3.2 Approximate Methods of Structural Analysis

*Add the following:*

Approximate methods include one-dimensional line-girder analysis using **LRFD** distribution factors.

For bridge superstructures meeting the requirements of **LRFD** 4.6.2.2, use the approximate live load distribution factors in the initial load rating.

Inverted-T beam bridges meeting the requirements of **SDG** 2.9C may use the live load distribution factors specified in that article.

For bridges constructed with composite prestressed deck panels, the live load distribution factors will be increased by a factor of 1.1 thus increasing the load and reducing the capacity.

### 6A.3.3 Refined Methods of Analysis

*Add the following:*

Refined methods of analysis include two or three dimensional models using grid or finite-element analysis.

All analyses will be performed assuming no benefit from the stiffening effects of any traffic railing barrier or other appurtenances.

Refined methods of analysis may utilize actual material properties as determined from field sampling and tests of the materials.

When a refined method of analysis is used, indicate the name, version, and date of the software used on the FDOT Load Rating Summary Tables.

Refined methods may be performed before attempting load tests (for load testing, see Section 8).

### C6A.3.2

*Add the following:*

This model assumes the structure acts as separate lines, in a girder-slab structure, each girder is basically assumed to act independently with limited distribution between the girders. The advantages of this model are that it is relatively easy to apply and that the computer generated output is easy to check long hand. Load distribution is achieved by use of the **LLDF** (live Load distribution factor). The VIRTIS program is a line model program.

Deck superstructures, utilizing composite prestressed deck panels have performed poorly. The deck cracked around the perimeter of the panel and the deck stiffness is softened therefore, a reduction in stiffness occurs. If conditions are severe, the live load distribution can be calculated as if the deck panels are simple supported on the girders.

### C6A.3.3

*Delete the second paragraph of the commentary in its entirety*

*Add the following:*

A two or three dimensional model looks at the structure globally and treats a girder-slab structure as a system using finite element methods. The SALOD program approximates this by comparing the structure to stored finite element solutions. The BRUFEM program is a sophisticated program that creates a finite element model of the structure to analyze and rate the structure.

When analysis is performed, certain minimum material properties are assumed based on design criteria or assumed material properties based on year of construction. Actual material properties may be significantly better due to suppliers exceeding minimum standards, concrete

increasing in strength with age, or structures material properties being higher grade than assumed. Therefore, testing material may result in higher material property values thus increasing the rating of the structure. Conversely, the opposite of the above statement is true for deteriorated conditions

## **6A.4 Load Rating Procedures**

### **6A.4.2 General Load Rating Equation**

*Add the following:*

When calculating the Service Limit State capacity for prestressed concrete flat slabs and girders with bonded tendons/strands, use transformed section properties when calculating stresses before losses (at transfer) and after losses (including loss of prestress.)

#### **6A.4.2.2 Limit States**

*Replace Table 6A.4.2.2-1 with FDOT Table 6A.4.2.2-1.*

### **C6A.4.2**

*Add the following:*

For a detailed explanation of stress calculations in prestressed concrete girders, see NCHRP 496. The correct use of transformed section properties for calculation of prestress losses is essential for the precise calculation of stresses at service limit state.

**FDOT Table 6A.4.2.2-1 Limit States and Load Factors for Load Rating**

Bridge Type	Direction	Limit State	Load Factors									
			Permanent Load			Transient Load			Design Load		Legal Load	Permit Load
			DC	DW	EL	FR	TU <sup>1</sup> CR SH	TG <sup>1</sup>	Inventory LL	Operating LL		
Steel	Longitudinal	Strength I	1.25	1.50	n/a	n/a	n/a	n/a	1.75	1.35	1.35	n/a
		Strength II	1.25	1.50	n/a	n/a	n/a	n/a	n/a	n/a	n/a	1.35
		Service II <sup>2</sup>	1.00	1.00	n/a	n/a	n/a	n/a	1.30	1.00	1.30	0.90
Reinforced Concrete	Longitudinal	Strength I	1.25	1.50	n/a	n/a	n/a	n/a	1.75	1.35	1.35	n/a
		Strength II	1.25	1.50	n/a	n/a	n/a	n/a	n/a	n/a	n/a	1.35
Prestressed Concrete (Flat Slab and Deck/Girder)	Longitudinal	Strength I	1.25	1.50	n/a	n/a	n/a	n/a	1.75	1.35	1.35	n/a
		Strength II	1.25	1.50	n/a	n/a	n/a	n/a	n/a	n/a	n/a	1.35
		Service III <sup>3</sup>	1.00	1.00	n/a	n/a	n/a	n/a	0.80	0.80	0.80	0.70
Wood	Longitudinal	Strength I	1.25	1.50	n/a	n/a	n/a	n/a	1.75	1.35	1.35	n/a
		Strength II	1.25	1.50	n/a	n/a	n/a	n/a	n/a	n/a	n/a	1.35
Post-tensioned Concrete	Longitudinal	Strength I	1.25	1.50	1.00	1.00	0.50	n/a	1.75	1.35	1.35	n/a
		Strength II	1.25	1.50	1.00	1.00	0.50	n/a	n/a	n/a	n/a	1.35 or 1.35 SL <sup>5</sup>
		Service III <sup>3</sup>	1.00	1.00	1.00	1.00	1.00	0.50	0.80	0.80 or 1.0 SL <sup>4</sup>	0.80 or 1.0 SL <sup>4</sup>	0.70 or 0.90 SL <sup>4</sup>
	Transverse	Strength I	1.25	1.50	1.00	n/a	n/a	n/a	1.75	1.35	n/a	n/a
		Strength II	1.25	1.50	1.00	n/a	n/a	n/a	n/a	n/a	n/a	n/a
		Service I	1.00	1.00	1.00	n/a	n/a	n/a	1.00	1.00	n/a	n/a

Notes:

1. TU and TG are considered for Service I and Service III Design Inventory only.
2. The Service II limit state need only be checked for compact steel girders. For all other steel girders, the Strength limit states will govern.
3. For Service III tensile stress limits, see FDOT Table 6A.5.4.1-1.
4. For I-girders use a load factor of 0.8 (inventory, operating, legal) or 0.7 (permit); for segmental box girders use 0.8 (inventory) or 1.0 and striped lanes (SL) (operating and legal) or 0.9 and striped lanes (SL) (permit).
5. For I-girders use a load factor of 1.35; for segmental box girders use 1.35 and striped lanes (SL).

**6A.4.2.3 Condition Factor**

*Delete the first sentence.*

*Add the following after Table 6A.4.2.3-1:*

The FDOT prefers load ratings be performed taking account of field measured deterioration. However, in the absence of measurements, global condition factors shall be used.

**6A.4.2.4 System Factor**

*Replace Table 6A.4.2.4-1 with FDOT Tables 6A.4.2.4-1, 2 and 3.*

*Replace the second paragraph with the following:*

The system factors of FDOT Tables 6A.4.2.4-1, 2 and 3 shall apply for flexural and axial effects at the Strength limit states. Higher values than those tabulated may be considered on a case-by-case basis with the approval of the Department. System factors need not be less than 0.85. In no case shall the system factor exceed 1.3.

*Delete the third paragraph.*

**FDOT Table 6A.4.2.4-1 General System Factors ( $\phi_s$ )**

<b>Superstructure Type</b>	<b>System Factors (<math>\phi_s</math>)</b>
Rolled/Welded Members in Two-Girder/Truss/Arch Bridges <sup>1</sup>	0.85
Riveted Members In Two-Girder/Truss/Arch Bridges <sup>1</sup>	0.90
Multiple Eye Bar Members in Truss Bridges	0.90
Floor beams with Spacing > 12 feet and Non-Continuous Stringers and Deck	0.85
Floor beams with Spacing >12 feet and Non-Continuous Stringers but with continuous Decks	0.90
Redundant Stinger subsystems between Floor beams	1.00
All beams in non-spliced concrete girder bridges	1.00
Steel Straddle Bents	0.85

Note:

1. Pertains to type of build-up or rolled members not type of connection

**FDOT Table 6A.4.2.4-2 System Factors ( $\phi_s$ ) for Post-Tensioned Concrete Beams**

Number of Girders in Cross Section	Span Type	Number of Hinges Required for Mechanism	System Factors ( $\phi_s$ )			
			Number of Tendons per Web			
			1	2	3	4
2	Interior	3	0.85	0.90	0.95	1.00
	End	2	0.85	0.85	0.90	0.95
	Simple	1	0.85	0.85	0.85	0.90
3 or 4	Interior	3	1.00	1.05	1.10	1.15
	End	2	0.95	1.00	1.05	1.10
	Simple	1	0.90	0.95	1.00	1.05
5 or more	Interior	3	1.05	1.10	1.15	1.20
	End	2	1.00	1.05	1.10	1.15
	Simple	1	0.95	1.00	1.05	1.10

Note: The tabulated values above may be increased by 0.05 for spans containing more than three intermediate, evenly spaced, diaphragms in addition to the diaphragms at the end of each span.

**FDOT Table 6A.4.2.4-3 System Factors ( $\phi_s$ ) for Steel Girder Bridges**

Number of Girders in Cross Section	Span Type	# of Hinges Required for Mechanism	With Diaphragms <sup>1</sup>	Without Diaphragms
2	Interior	3	1.00	0.85
	End	2	1.00	0.85
	Simple	1	1.00	0.85
3 or 4	Interior	3	1.00	1.00
	End	2	1.00	0.95
	Simple	1	1.00	0.90
5 or more	Interior	3	1.00	1.00
	End	2	1.00	1.00
	Simple	1	1.00	0.95

Notes:

1. With at least three evenly spaced intermediate diaphragms (excluding end diaphragms) in each span.
2. The above tabulated values may be increased by 0.05 for riveted members.

## 6A.4.4 Legal Load Ratings

### 6A.4.4.1 Purpose

*Replace the 1st sentence of the 1st paragraph with the following:*

Bridges that do not have sufficient capacity under the design-load rating operating level (i.e. RF 1.4 or less) shall be load rated for the SU4, C5, and ST5 legal loads to establish the potential need for load posting or strengthening.

If the SU4 or C5 or ST5 Legal Load ratings are less than one, ratings at operating level may be required for SU2, SU3, C3 and C4.

*Replace this article with the following:*

For all span lengths, the critical load effects shall be created by:

For all load effects, Florida legal loads defined in Figures 6A.4.4.2.1-1 and 6A.4.4.2.1-2 Assume the same legal trucks are in each loaded lane; do not mix trucks.

For negative moments and reactions at interior supports, a lane load of 0.2 klf combined with two of the same legal trucks, applied separately, multiplied by 0.75 heading in the same direction separated by 30 ft.

In addition, for span lengths greater than 200 ft., critical load effects shall be created by:

The same Florida legal loads, applied separately, multiplied by 0.75 and combined with a lane load of 0.2 klf.

Dynamic load allowance shall be applied to the legal vehicles and not the lane loads.

FDOT Figure 6A.4.2.1-1 Florida Legal Trucks

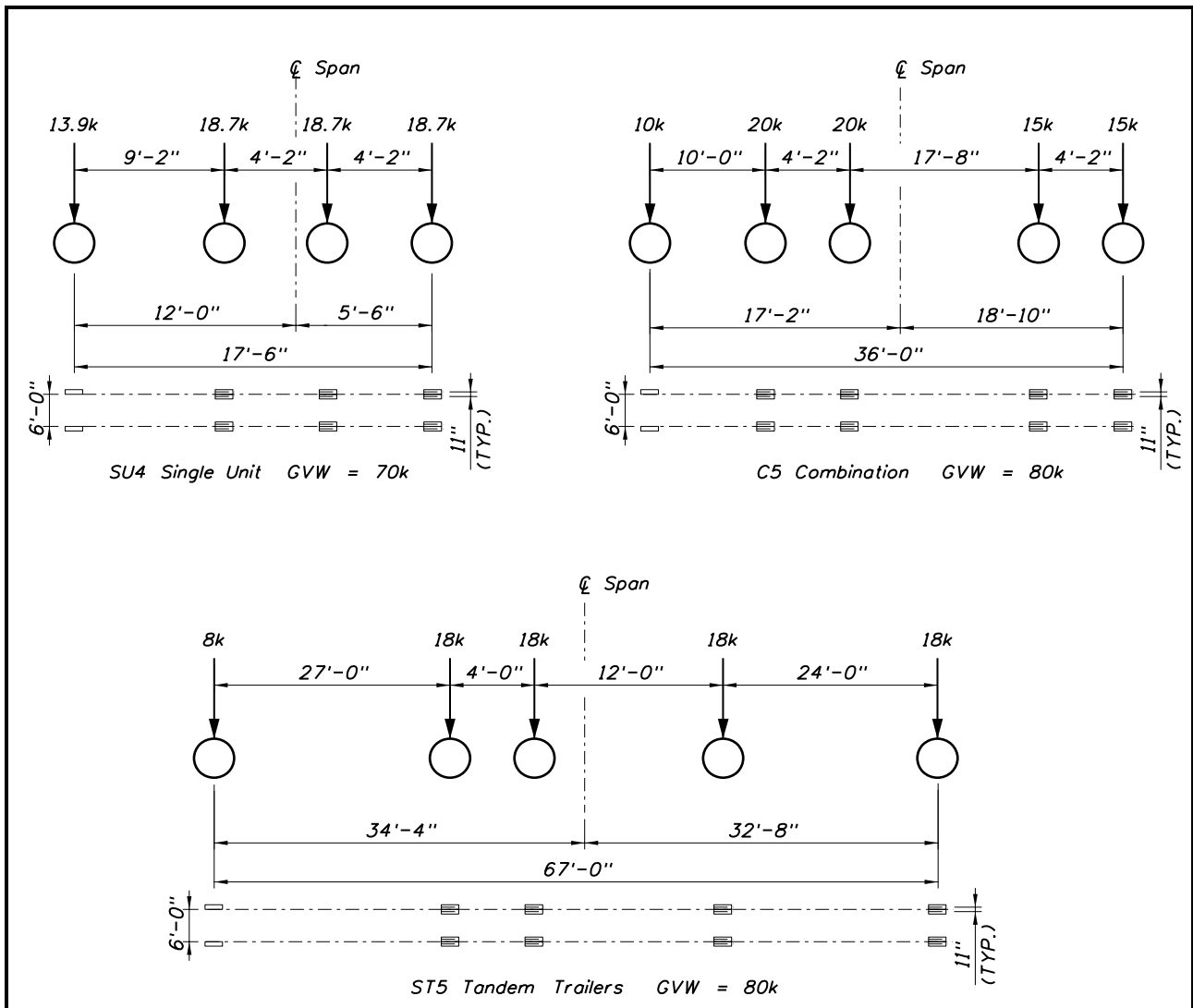

FDOT Figure 6A.4.4.2.1-2 Additional Florida Legal Trucks

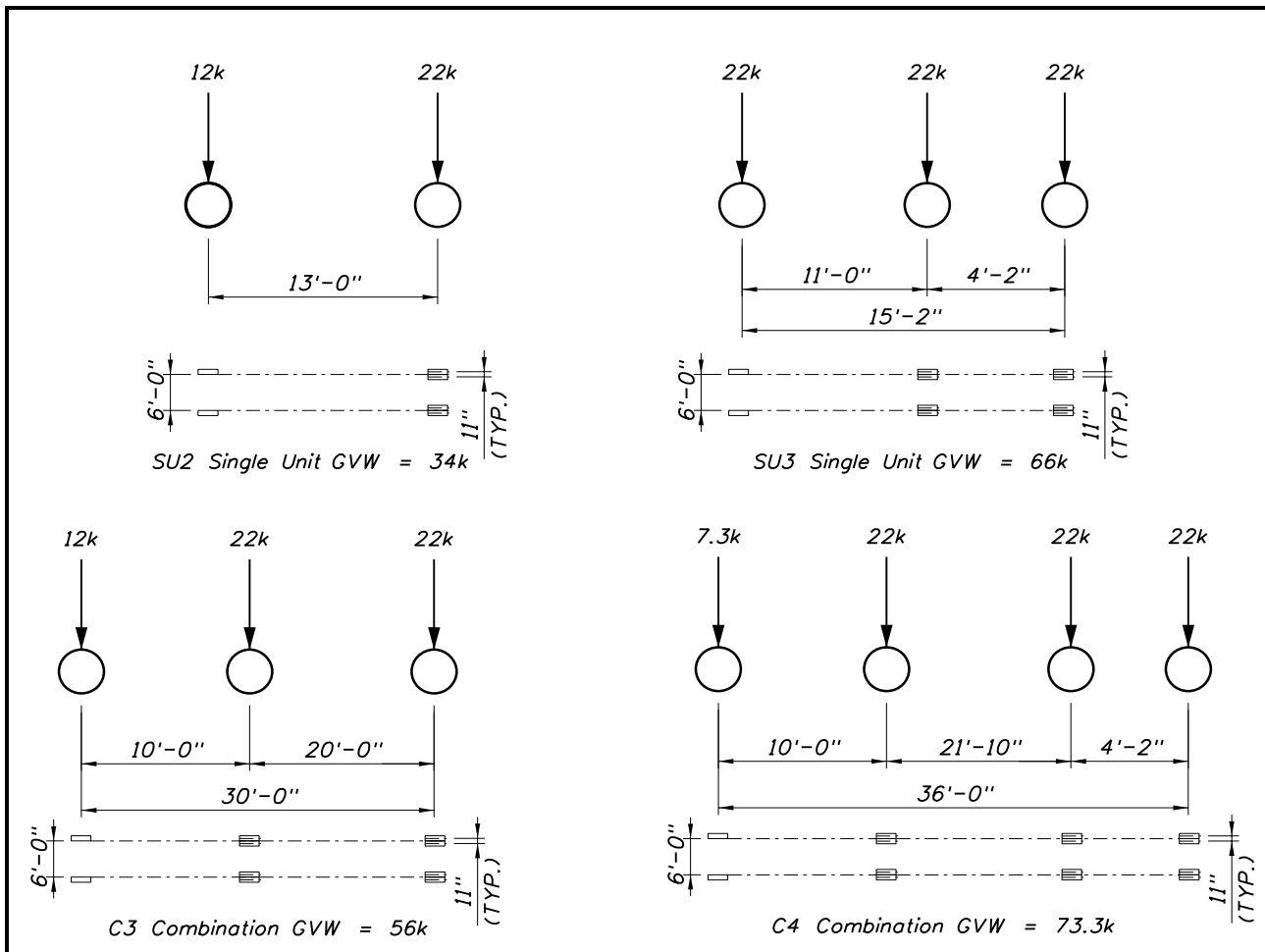

**6A.4.4.2.3 Generalized Live Load Factors:  $\gamma_L$**

Revise Table 6A.4.4.2.3a-1 as follows:

For all Traffic Volumes, revise all Load Factors to 1.35.

**C6A.4.4.2.3**

Add the following:

The **LRFD** HL-93 live-load model envelopes FDOT legal loads. As such, if the live load factor of 1.35 for the design-load operating rating yields a reliability index consistent with traditional operating ratings, this live load factor can be used for legal-load rating of the FDOT legal loads.

Live load factors for FDOT legal loads are not specified as a function of ADTT.

## 6A.4.5 Permit Load Ratings

### 6A.4.5.1 Background

*Add the following:*

Calculate the capacity for permit trucks using one lane distribution factor for single trip permits and two or more lanes distribution factor for routine or annual permits as shown in Table 6A.4.5.4.2a-1. The two or more lanes distribution factor assumes the permit vehicle is present in all loaded lanes and **LRFD** live load distribution equations are used. Do not use **LRFD** formula 4.6.2.2.4-1 since mixed traffic calculations are not performed.

### 6A.4.5.2 Purpose

*Add the following:*

Bridges designed after January 1, 2005 are required to have rating factors for the FL120 permit truck. Rate the FL120 for both Strength and Service Limit State.

#### 6A.4.5.4.2 Load Factors

##### 6A.4.5.4.2a Routine (Annual) Permits

*Revise Table 6A.4.5.4.2a-1 as follows:*

For all Permit Types, revise all the Load Factors by Permit Type to 1.35 except the escorted single trip load factor will remain 1.15.

*Add the following:*

The FL120 permit truck shall be considered as routine annual permit vehicle to be used to verify overload

### C6A.4.5.1

*Add the following:*

Florida has chosen to apply a service limit state rating for permitting overload vehicles using load factors that include a reduced reliability factor. The live load factor is applied to a capacity calculated with the rating vehicle placed in all lanes. The load factor was developed to simulate a rating vehicle in the rating lane with adjoining lanes filled with legal vehicles (tractor trailers). The combined effect of these loads is multiplied by the multiple presence factor of 0.9 (Ontario Bridge Code).

#### C6A.4.5.4.2

*Add the following:*

Since routine permits are evaluated using the FL120 permit truck and values of ADTT are not well known, a single load factor is specified for routine permit load rating. Similarly, a single load factor is specified for single-trip permits.

##### C6A.4.5.4.2a

*Add the following:*

The FL120 permit truck is conceived to be a benchmark to past load factor design (**LFD**) practice in which the HS-20 truck was rated at the operating level with a load factor of 1.3. A **LRFR** Permit Load rating for the FL120 permit truck equal to 1.0 is equivalent to an **LFD** operating rating for the HS-20 truck equal to 1.67. The axle spacing of the FL120 is not changed to

capacity of Florida bridges. The FL120 shall be checked at Strength Limit State and Service Limit State as noted in FDOT Table 6A.4.2.2-1 and the minimum rating factor for new bridges is 1.0.

For spans over 200 feet assume the FL120 permit truck with coincident 0.20 kips per foot lane load. Assume the permit trucks are in each lane; do not mix trucks.

The FL120 permit truck configuration is shown in the figure below:



FL120 Permit Vehicle GVW = 120k

emulate a truck crane.

It is reasonable to use the multiple-lane distribution factor for the permit load rating since the force effects of the permit trucks are similar to the HL-93 notional load have been shown to be very similar. Thus, this application is close to the intent of the AASHTO **LRFR** methodology where the HL-93 is placed in remote lanes. The FL120 is intended to replicate the traditional HS20 operating rating where all lanes were occupied by the same truck. Thus, the use of multiple-lane distribution factors is equally appropriate for the FL120 permit load rating.

### 6A.4.5.5 Dynamic Load Allowance

*End the first sentence after legal loads.*

*Add the following:*

For exclusive-use vehicles with escort and speeds less than or equal to 5 mph, IM may be decreased to 0%.

### 6A.4.5.8 Adjoining Lane Loading

When performing refined analysis for permit vehicles, combine the permit vehicle with the same permit vehicle in the adjoining lanes. For spans over 200 feet, add a 0.20 kip per foot lane load to all vehicle loadings.

## 6A.5 Concrete Structures

### 6A.5.2 Material

*Add the following:*

For concrete made with Florida aggregate calculate the modulus of elasticity by applying a 0.9 factor times the value found in the specifications.

See **SDG** 1.4.1 for the appropriate value for the modulus of rupture.

### 6A.5.4 Limit States

#### 6A.5.4.1 Design-Load Rating

*Add the following:*

For prestressed concrete bridges, perform load ratings for:

1. Service I transverse compressive and tensile stress checks in the deck of transversely prestressed bridges.
2. Service III tensile stress checks in the longitudinal direction of all prestressed concrete bridges.

The stress limits given in FDOT Table 6A.5.4.1-1 shall be satisfied by all prestressed concrete bridges.

Prestressed deck/girder bridges with a continuous deck but without continuous girders shall be load rated as simple spans.

#### C6A.5.4.1

*Delete the first sentence of the commentary.*

**FDOT Table 6A.5.4.1-1 Stress Limits for Prestressed Concrete Bridges**

Condition	Design Inventory	Design Operating, Legal and Permit
<b>Compressive Stress - All Bridges (Longitudinal or Transverse)</b>		
Compressive stress under effective prestress, permanent loads, and transient loads (Allowable compressive stress shall be reduced according to <i>LRFD</i> 5.9.4.2.1 when slenderness of flange or web is greater than 15)	0.60f'c	0.60f'c
<b>Longitudinal Tensile Stress in Precompressed Tensile Zone - Nonsegmental Bridges (including Post-Tensioned I-Girders)</b>		
For components with bonded prestressing tendons or reinforcement that are subject to not worse than:		
(a) an extremely aggressive corrosion environment.	3√f'c psi	7.5√f'c psi
(b) slightly or moderately aggressive corrosion environments.	6√f'c psi	7.5√f'c psi
<b>Longitudinal Tensile Stress in Precompressed Tensile Zone - Segmental Box Girder Bridges</b>		
For components with bonded prestressing tendons or reinforcement that are subject to not worse than:		
(a) an extremely aggressive corrosion environment.	3√f'c psi	3√f'c psi
(b) slightly or moderately aggressive corrosion environments.	6√f'c psi	6√f'c psi
For components with unbonded prestressing tendons	No Tension	No Tension
For components with Type B joints (dry joints, no epoxy)	100 psi comp	No Tension
<b>Tensile Stress in Other Areas - Segmental Box Girder Bridges</b>		
Areas without bonded reinforcement	No tension	No tension
Areas with bonded reinforcement sufficient to carry the tensile force in the concrete calculated on the assumption of an uncracked section is provided at a stress of 0.5fy (<30 ksi)	6√f'c psi tension	6√f'c psi tension
<b>Transverse Tension, Bonded Post-tensioned Deck Slabs</b>		
Tension in the transverse direction in the precompressed tensile zone calculated on the basis of an uncracked section (i.e. top prestressed slab) for:		
(a) an extremely aggressive corrosion environment	3√f'c psi	6√f'c psi
(b) slightly or moderately aggressive corrosion environments	6√f'c psi	6√f'c psi
<b>Principal Tensile Stress at Neutral Axis in Webs - Segmental Box Girder Bridges</b>		
All types of segmental construction with internal and/or external tendons.	3.5√f'c psi tension	3.5√f'c psi tension

### 6A.5.4.2 Legal Load Rating and Permit Load Rating

#### 6A.5.4.2.2a Legal Load Rating

*Delete both sentences and replace with the following:*

Legal load rating of prestressed concrete bridges is based on satisfying strength and service limit states (see FDOT Table 6A.4.2.2-1)

#### 6A.5.4.2.2b Permit Load Rating

*Delete the first sentence and replace with the following:*

Permit load rating of prestressed concrete bridges is based on satisfying Strength and Service limit states (see FDOT Table 6A.4.2.2-1).

*Delete the second paragraph.*

### 6A.5.7 Minimum Reinforcement

*Add the following:*

See **SDG** 4.1.5 for clarification of the appropriate application of minimum reinforcing at the ends of simply supported bridge girders.

### 6A.5.9 Evaluation for Shear

*Delete the second sentence and replace with the following:*

Design and legal loads shall be checked for shear.

*Add the following:*

For shear load rating, use any of the methods allowed in **LRFD**. If the maximum rating factor is still less than 1, use the General Procedure of **LRFD** 5.8.3.4.2 with area of stirrup reinforcement intersecting the plane created by the theta ( $\theta$ ) angle starting at the design section under review and projecting toward the support. This plane will not project past the intersection of

#### C6A.5.4.2.2a

*Delete the entire commentary*

#### C6A.5.4.2.2b

*Delete the first and second paragraphs.*

Florida has elected to use a service limit state for permit analysis and has removed the check for stress in the reinforcing at the strength limit state.

#### C6A.5.9

The concept of using the area of steel starting at the design section under review and projecting toward the support is shown below:

center-line of the bearing and the centroid of the prestressing steel on the tension side of the member.

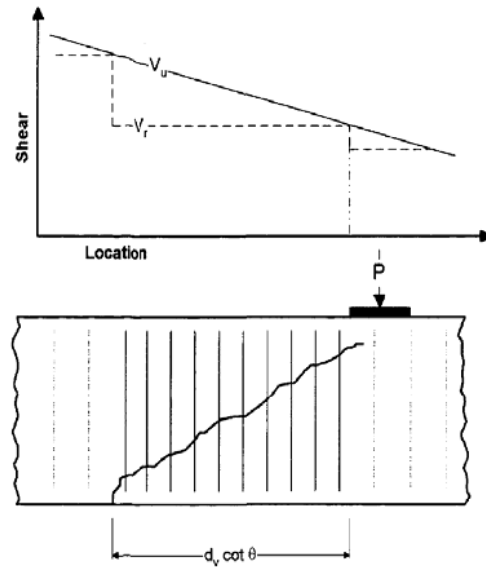

**6A.5.12 Temperature, Creep and Shrinkage Effects**

*Delete the first paragraph and replace with the following:*

At the service limit state, all prestressed concrete bridges shall include the effect of uniform temperature (TU), when appropriate, creep (CR), and shrinkage (SH). In addition, temperature gradient (TG) shall be included for post-tensioned beam and box girder structures. See FDOT Table 6A.4.2.2-1 for clarification.

**6A.5.13 Rating of Segmental Concrete Bridges**

**6A.5.13.2 General Rating Requirements**

*Add the following:*

Six features of concrete segmental bridges are to be load rated at the Design Load (Inventory and Operating) Levels. Three of these criteria are at the Service Limit State and three at the Strength Limit State, as follows:

**C6A.5.13.2**

*Add the following:*

For general references, see ***New Directions for Florida Post-Tensioning Bridges, Vol. 10 A*** "Load Rating Post-Tensioned Concrete Segmental Bridges". **Volume 10A** can be found on the Structures Design web site at the following address:  
[www.dot.state.fl.us/structures/posttensioning.htm](http://www.dot.state.fl.us/structures/posttensioning.htm)

At the Service Limit State:

- Longitudinal Box Girder Flexure
- Transverse Top Slab Flexure
- Principle Web Tension

At the Strength Limit State:

- Longitudinal Box Girder Flexure
- Transverse Top Slab Flexure
- Web Shear

For detailed load rating requirements, see Appendix J6A.

In accordance with AASHTO **LRFR** Equation 6A.4.2.1.-1, the general Load Rating Factor, RF, shall be determined according to the formula:

Where:

For Strength Limit States:

$C = \text{Capacity} = (\phi_c \times \phi_s \times \phi) R_n$ .

$\phi_c$  = Condition Factor per Article 6A.4.2.3.

$\phi_s$  = System Factor per Article 6A.4.2.4

$\phi$  = Strength Reduction Factor per **LRFD**.

$R_n$  = Nominal member resistance as inspected, measured and calculated according to formulae in **LRFD**.

For Service Limit States:

$C = f_R$  = Allowable stress at the Service Limit State (FDOT Table 6A.5.4.1-1).

## 6A.6 Steel Structures

### 6A.6.4 Limit States

#### 6A.6.4.1 Design-Load Rating

*Delete both paragraphs and replace with the following:*

Bridges shall not be rated for fatigue. If the fatigue crack growth is anticipated,

#### C6A.6.4.1

*Add the Following:*

The estimate of the remaining fatigue life of Section 7 of the **MBE** requires a historical record of past truck traffic in

Section 7 of the **MBE** can be used to estimate the remaining fatigue life.

The stress limits given in FDOT Table 6A.6.4.1-1 shall be satisfied by all prestressed decks on steel bridges.

terms of average daily truck traffic (ADTT) and projected future traffic. Many times, conservative recreation and projection of traffic volumes produces a worst case scenario which results in low remaining fatigue lives or totally exhausted fatigue lives. As fatigue life estimates are based upon statistical evaluation of laboratory tests, different levels of confidence are presented in Section 7. The minimum expected fatigue life, the evaluation fatigue life and the mean fatigue life are based upon approximately 98%, 85% and 50% probabilities of cracking, respectively. Judgment must be used in evaluating the results of the fatigue-life estimates.

**FDOT Table 6A.6.4.1-1 Stress Limits for Prestressed Concrete Decks on Steel Bridges**

Condition	Design Inventory	Design Operating, Legal and Permit
<b>Transverse Tension, Bonded Post-tensioned Deck Slabs:</b>		
Tension in the transverse direction in the precompressed tensile zone calculated on the basis of an uncracked section (i.e. top prestressed slab) for:		
(a) an extremely aggressive corrosion environment	3√f'c psi	6√f'c psi
(b) slightly or moderately aggressive corrosion environments	6√f'c psi	6√f'c psi

**6A.6.13 Fracture-Critical Members (FCMs)**

As with all other steel members, the appropriate system factors of FDOT Tables 6A.4.2.4-1 or 6A.4.2.4-3 shall be applied in the ratings of FCMs.

Steel members which are traditionally classified as FCMs may be declassified through analysis if the material satisfies the FCM fracture-toughness of **LRFD** Table 6.6.2-2. After the approval of an exception based upon an approved refined analysis demonstrating that the bridge with the fractured member can continue to carry a significant portion of the design load, the member may be declassified and treated as a redundant member. See LRFD Article C6A.6.2. After declassification, the member may be rated using a system factor of 1.0.

**6A.6.14 Double-Leaf Bascule with Span Locks**

Evaluate all appropriate load combinations at Strength II Limit State. See Section 6A.1.8.8 for additional criteria.

**C6A.6.13**

Only FCMs which are fabricated from material meeting the FCM fracture-toughness requirements are candidates for declassification. Newer bridges designed, fabricated and constructed since the concept of FCMs was introduced should meet this material requirement. The demonstration of non-fracture criticality must include an analysis of the damaged bridge with the member in question fractured and a corresponding dynamic load representing the energy release of the fracture. Acceptable remaining load carrying capacity may be considered equal to the full factored load of the Strength I load combination associated with the number of striped lanes.

**Appendix A6A Load and Resistance Factors Rating Flow Chart**

*Replace the flowchart with FDOT flowcharts in Section 2.2.*

**Appendix B6A Limit States and Load Factors for Load Rating**

*Delete all four tables and use FDOT Table 6A.4.2.2-1 .*

**Appendix D6A AASHTO Legal Loads**

*Delete section a) and use the Florida legal trucks defined in article 6A.4.4.2.1.*

**Appendix J6A Rating of Segmental Concrete Box Girder Bridges Step-By-Step Supplement****J6A.1 Load Factors and Load Combinations**

Load factors and load combinations for the Strength and Service Limit States shall be made in accordance with FDOT Table 6A.4.2.2-1. Load factors for permanent (e.g. dead) loads and transient (e.g. temperature) loads are provided. Note: one-half thermal gradient (0.5TG) is used only for longitudinal Service Inventory conditions.

STRENGTH I and II and SERVICE I and III limit states are used in the context of their definitions as given in FDOT Table 6A.4.2.2-1 summarizing:

STRENGTH I - applies to Design Load Rating (Inventory and Operating) and Legal Load Rating.

STRENGTH II - applies only to Permit Loads.

SERVICE I - applies primarily for concrete in compression but is also to prevent yield of tension face reinforcement or prestress under overloads (permits). This limit state is extended to concrete tension in transversely prestressed deck slabs, typical of most segmental bridges.

SERVICE III - applies to concrete in longitudinal tension and principal tension. Load factors for SERVICE III for Design Operating, Legal, and Permit ratings have been selected in conjunction with either higher allowable tensile stress or use of the number of striped lanes.

The following is a detailed checklist of the load applications, combinations and circumstances necessary to satisfy FDOT and AASHTO **LRFR** ratings.

**J6A.2 Design Load Rating – Inventory****Transverse:**

- Apply HL93 Truck or Tandem (FDOT Table 6A.4.2.2-1).
- Do not apply uniform lane load.
- Apply same axle loads in each lane if multiple lane loading applies.
- Apply Dynamic Load Allowance, IM = 1.33 on Truck or Tandem.
- For both Strength and Service Limit States, use number of load lanes per **LRFD**.

- Apply multi-presence factor: one lane,  $m = 1.20$ ; two lanes,  $m = 1.00$ ; three,  $m = 0.85$ ; four or more,  $m = 0.65$ . (Maximum value of  $m = 1.20$  is the appropriate AASHTO **LRFD** / **LRFR** current criteria to allow for rogue vehicles).
- Place loads in full available width as necessary to create maximum effects.
- Apply pedestrian live load as necessary (counts as one lane for “m”).
- Apply no Thermal Gradient transversely.
- Use SERVICE I Limit State with live load factor,  $\gamma_L = 1.00$  and limit concrete transverse flexural stresses to values in FDOT Table 6A.5.4.1-1 . (Note: = 1.00 as AASHTO **LRFR**).
- For STRENGTH I Limit State use live load factor,  $\gamma_L = 1.75$ .

**Longitudinal:**

- Apply HL93 Truck or Tandem, including 0.64 kip/ft uniform lane load (FDOT Table 6A.4.2.2-1).
- Apply same load in each lane.
- Apply Dynamic Load Allowance,  $IM = 1.33$  on Truck or Tandem only.
- For both Strength and Service Limit States, use number of load lanes per LRFD.
- Apply multi-presence factor: one lane,  $m = 1.2$ ; two lanes,  $m = 1.00$ ; three,  $m = 0.85$ ; four or more,  $m = 0.65$ . (Maximum value of  $m = 1.20$  is the appropriate AASHTO **LRFD** / **LRFR** current criteria for notional loads and rogue vehicles).
- For negative moment regions: apply 90% of the effect of two Design Trucks of 72 kip GVW placed in adjacent spans and spaced a minimum of 50 feet apart between the leading axle of one and the trailing axle of the other, plus 90% of uniform lane load.
- Place loads in full available width as necessary to create maximum effects.
- Apply pedestrian live load as necessary (counts as one lane for “m”).
- For Thermal Gradient, apply 0.50TG with live load for Service but zero TG for Strength.
- Use SERVICE III Limit State, use live load factor  $\gamma_L = 0.8$ , and limit longitudinal tensile stress to values in FDOT Table 6A.5.4.1-1.
- For STRENGTH I Limit State use live load factor,  $\gamma_L = 1.75$ .

### J6A.3 Design Load Rating – Operating

#### Transverse:

- Apply one HL93 Truck or Tandem per lane (FDOT Table 6A.4.2.2-1).
- Do not apply uniform lane load.
- Apply same axle loads in each lane if multiple lane loading applies.
- Apply Dynamic Load Allowance,  $IM = 1.33$  on Truck or Tandem.
- For both Strength and Service Limit States, use number of load lanes per **LRFD**.
- Apply multi-presence factor: one and two lanes,  $m = 1.0$ ; three,  $m = 0.85$ ; four or more,  $m = 0.65$ . (Maximum limit of 1.0 applies because this is a rating for specific (defined) axle loads, not notional loads or rogue vehicles).
- Place loads in full available width as necessary to create maximum effects.
- Apply pedestrian live load as necessary (counts as one lane for “m”).
- Apply no Thermal Gradient transversely.
- Use SERVICE I Limit State with live load factor,  $\gamma_L = 1.00$  and limit concrete transverse flexural stresses to values in FDOT Table 6A.5.4.1-1.
- For STRENGTH I Limit State use live load factor,  $\gamma_L = 1.35$ .

#### Longitudinal:

- Apply HL93 Truck or Tandem, including 0.64 kip/ft uniform lane load (FDOT Table 6A.4.2.2-1).
- Apply same load in each lane.
- Apply Dynamic Load Allowance,  $IM = 1.33$  on Truck or Tandem only.
- For the Strength Limit State, use number of load lanes per **LRFD**.
- For the Service Limit State use the number of striped lanes.
- Place loads in full available width as necessary to create maximum effects (for example, in shoulders).
- Multi-presence factor: HL93 Design Load (including uniform lane load) one lane,  $m = 1.20$ ; two lanes,  $m = 1.00$ ; three,  $m = 0.85$ ; four or more,  $m = 0.65$ . (The maximum value of 1.20 for one lane is necessary because the load is a notional load with a uniform lane load component).
- For negative moment regions, apply 90% of the effect of two Design Trucks of 72 kip GVW placed in adjacent spans and each spaced a minimum of 50 feet apart between the leading axle of one and the trailing axle of the other, plus 90% of 0.64 kip/LF uniform lane load.
- Apply pedestrian live load as necessary (counts as one lane for “m”).
- Apply no Thermal Gradient.

- Use SERVICE III Limit State, use live load factor  $\gamma_L = 1.0$ , striped lanes, and limit concrete longitudinal flexural tensile and principal tensile stresses to values in FDOT Table 6A.5.4.1-1.
- For STRENGTH I Limit State use live load factor,  $\gamma_L = 1.35$ .

#### J6A.4 Legal Load Rating

##### Longitudinal:

- Apply FDOT Legal Load Trucks SU4, C5 and ST5 (FDOT Table 6A.4.2.2-1).
- Apply same truck load in each lane using only one truck per lane (i.e. do not mix Trucks).
- Apply no uniform lane load.
- Apply Dynamic Load Allowance,  $IM = 1.33$  on Legal.
- For the Strength Limit State, use number of load lanes per **LRFD**.
- For Service Limit States, use number of striped lanes.
- Place loads in full available width as necessary to create maximum effects (i.e., in shoulders).
- Use multi-presence factor: one and two lanes,  $m = 1.00$ ; three,  $m = 0.85$ ; four or more,  $m = 0.65$ .
- Apply no pedestrian live load (unless very specifically necessary for the site - in which case it counts as one lane for establishing “m”).
- Apply no Thermal Gradient.
- Use SERVICE III Limit State, use live load factor,  $\gamma_L = 1.0$ , striped lanes, and limit concrete longitudinal flexural tensile and principal tensile stresses to values in FDOT Table 6A.5.4.1-1.
- For STRENGTH I Limit State, use live load factor,  $\gamma_L = 1.35$ .
- Negative moments load ratings may be limited by AASHTO **LRFR** 6A.4.4.2.1. If the value of the Rating Factor for the AASHTO Limiting Critical Load is less than 1.00, then the basic rating factor for all FDOT Legal Loads shall be reduced by multiplying by this value. See Appendix D6A(c) for load model.

#### J6A.5 Permit Load Rating

##### Longitudinal, annual “blanket” permits:

- Apply ONE Permit Vehicle (FL120) in all lanes (FDOT Table 6A.4.2.2-1).
- For spans over 200 feet, apply a uniform lane load of 0.20 kip / LF in the lane with the permit vehicle. This uniform lane load should be applied beyond the footprint of the vehicle to create the maximum effects. However, for convenience, it may be applied coincident with the vehicle.
- For the Strength Limit State, use number of load lanes per **LRFD**.

- For Service Limit States, use a reduced load factor or see FDOT Table 6A.4.2.2-1.
- Place loads in full available width as necessary to create maximum effects (for example, in shoulders).
- Use multi-presence factor: one and two lanes,  $m = 1.00$ ; three,  $m = 0.85$ ; four or more,  $m = 0.65$ .
- Dynamic Load Allowance,  $IM = 1.33$  on Permit Trucks.
- Apply no pedestrian live load (unless very specifically necessary for the site - in which case it counts as one lane for establishing “m”).
- Apply no Thermal Gradient.
- Use SERVICE III Limit State, use live load factor  $\gamma_L = 0.9$ , striped lanes, and limit concrete longitudinal flexural tensile and principal tensile stresses to values in FDOT Table 6A.5.4.1-1 as appropriate.
- For STRENGTH II Limit State, use live load factor,  $\gamma_L = 1.35$ .
- Reduced Dynamic Load Allowance (IM) or live load factor ( $\gamma_L$ ) may be considered only to avoid restrictions.

#### **J6A.6 Capacity – Strength Limit State**

The capacity of a section in transverse and longitudinal flexure may be determined using any of the relevant formulae or methods in the *LRFD Specifications*, or *AASHTO Guide Specification for Segmental Bridges* dated 1999, including more rigorous analysis techniques involving strain compatibility. The latter should be used in particular where the capacity depends upon a combination of both internal (bonded) and external (unbonded) tendons.

For load rating, the capacity should be determined based upon actual rather than specified or assumed material strengths and characteristics. Concrete strength should be found from records or verified by suitable tests. If no data is available, the specified design strength may be assumed, appropriately increased for maturity. All new designs will assume the plan specified concrete properties. Post construction will include updated concrete properties.

In particular, for shear or combined shear with torsion, the capacity at the Strength Limit State for segmental bridges should be calculated according to the *AASHTO Guide Specification for Segmental Bridges*. The “Modified Compression Field Theory” of *LRFD* may be used as an alternative, but only for structures with continuously bonded reinforcement (e.g. large boxes cast-in-place in cantilever or on falsework).

#### **J6A.7 Allowable Stress Limits – Service Limit State**

Allowable stresses for the Service Limit State are given in FDOT Table 6A.5.4.1-1. The intent is to ensure a minimum level of durability for FDOT bridges that avoids the development or propagation of cracks or the potential breach of corrosion protection afforded to post-tensioning tendons. Also, these are recommended for the purpose of designing new bridges.

### **J6A7.1 Longitudinal Tension in Joints**

#### **Type “A” Joints with Minimum Bonded Reinforcement**

The Service level tensile stress is limited to  $3\sqrt{f'_c}$  or  $6\sqrt{f'_c}$  (psi) for cast-in-place joints with continuous longitudinal mild steel reinforcing for Design Inventory Rating. (Reference: **AASHTO Guide Specification for Segmental Bridges** and **LRFD** Table 5.9.4.2.2-1). Reduced reliability at Design Operating, Legal and Permit conditions is attained by using the number of striped lanes and by allowing an increase in tensile stress to  $7.5\sqrt{f'_c}$  (psi) (FDOT Table 6A.5.4.1-1 ).

#### **Type “A” Epoxy Joints with Discontinuous Reinforcement**

The Service level tensile stress is limited to zero tension for epoxy joints for Design Inventory, Design Operating, Legal, and Permit ratings. (Reference: **AASHTO Guide Specification for Segmental Bridges** and **LRFD** Table 5.9.4.2.2-1). Reduced reliability is attained by using the number of striped lanes.

#### **Type “B” Dry Joints**

Early precast segmental bridges with external tendons and non-epoxy filled, Type-B (dry) joints were designed to zero longitudinal tensile stress. In 1989, a requirement for 200 psi residual compression was introduced with the first edition of the **AASHTO Guide Specification for Segmental Bridges**. This was subsequently revised in 1998 to 100 psi compression. Service Level Design Inventory Ratings shall be based on a residual compression of 100 psi for dry joints. For Design Operating, Legal, and Permit Ratings, the limit is zero tension. (Reference: **AASHTO Guide Specification for Segmental Bridges** and **LRFD** Table 5.9.4.2.2-1). Reduced reliability is attained by using the number of striped lanes.

### **J6A.7.2 Transverse Tensile Stress**

For a transversely prestressed deck slab, the allowable flexural stresses for concrete tension are provided in FDOT Table 6A.5.4.1-1 : namely, for Inventory  $3\sqrt{f'_c}$  or  $6\sqrt{f'_c}$  (psi) and for Operating  $6\sqrt{f'_c}$  (psi).

### **J6A.7.3 Principal Tensile Stress – Service Limit State**

A check of the principal tensile stress has been introduced to verify the adequacy of webs for longitudinal shear at service. This is to be applied to both for the design of new bridges and Load Rating. The verification, made at the neutral axis, is the recommended minimum prescribed procedure, as follows:

Sections should be considered only at locations greater than “H/2” from the edge of the bearing surface or face of diaphragm, where classical beam theory applies: i.e. away from discontinuity regions. In general, verification at the elevation of the neutral axis may be made without regard to any local transverse flexural stress in the web itself given that in most large, well proportioned boxes the maximum web shear force and local web flexure are mutually exclusive load cases. This is a convenient simplification. However, should the neutral axis lie in a part of the web locally thickened by fillets, then the check should be made at the most critical elevation, taking into account any coexistent longitudinal flexural stress. Also, if the neutral axis (or critical elevation) lies

within 1 duct diameter of the top or bottom of an internal, grouted duct, the web width for calculating stresses should be reduced by half the duct diameter.

Calculate principle tension without the effect of thermal gradient.

Classical beam theory and Mohr's circle for stress should be used to determine shear and principal tensile stresses. At the Service Limit State, the shear stress and Principal Tensile Stress should be determined at the neutral axis (or critical elevation) under the long-term residual axial force, maximum shear and/or maximum shear force combined with shear from torsion in the highest loaded web, using the live load factor shown in FDOT Table 6A.4.2.2-1. The live load should then be increased in magnitude so the shear stress in the highest loaded web increases until the Principal Tensile Stress reaches its allowable maximum value (FDOT Table 6A.5.4.1-1).

The Service Limit State Rating Factor is the ratio between the live load shear stress required to induce the maximum Principal Tensile Stress to that induced by the live load factor shown in FDOT Table 6A.4.2.2-1.

### **J6A.8 Local Details**

Local Details (i.e. diaphragms, anchorage zones, blisters, deviation saddles, etc.) in concrete segmental bridges are discussed in Chapter 4 of Volume 10A ***Load Rating Post-tensioned Concrete Segmental Bridges***. If a detail shows signs of distress (cracks), a structural evaluation should be performed for the Strength Limit State. The influence of anchorage zones shall be checked for principal tension in accordance with ***Structure Design Guidelines*** Section 4.5.11, Principal Tensile Stresses.

## Part B – Allowable Stress Rating and Load Factor Rating

### 6B.1 General

*Add the following paragraph:*

Use the 17th Edition of the AASHTO **Standard Specification for Highway Bridges** with the allowable stresses shown in FDOT Table 6A.5.4.1-1.

#### 6B.1.4 Application of Standard Design Specifications

*Add the following before the existing text:*

When using the AASHTO **Standard Specifications for Highway Bridges**, follow explicitly the guidance in the Specifications. All deviations from the Specifications require approval by the FDOT.

### 6B.6 Nominal Capacity

#### 6B.6.3 Load Factor Method

##### 6B.6.3.3 Prestressed Concrete

*After the last paragraph, add the following:*

See **SDG** 4.1.5 for clarification of the appropriate application of minimum reinforcing at the ends for simply supported bridge girders.

### 6B.7 Loadings

#### 6B.7.2.2 Truck Loads

*Add the following:*

Each load factor rating will include the following:

- A. HS20 (lane or truck which governs the rating) at the operating and inventory level
- B. SU4, C5 and ST5 Legal trucks at the operating level (Florida legal vehicles) as defined in Figure 6A.4.4.2.1-1.

- C. If the SU4 or C5 or ST5 Legal Load ratings are less than one; ratings at operating level may be required for SU2, SU3, C3 and C4 as defined in Figure 6A.4.4.2.1-2.

## 7 POSTING OF BRIDGES AND POST AVOIDANCE

### 7.1 General

The bridge owner shall post all bridges in the National Bridge Inventory (NBI) within 90 or 180 days of opening or a change in load rating for on-system or off-system bridges, respectively.

Before weight limit posting is recommended, posting avoidance strategies should be discussed and approved by the FDOT and may require additional analysis.

### 7.2 Posting Avoidance

Posting avoidance is the application of engineering judgment to a load rating by modifying the specification defined procedures through use of variances and exceptions.

The following methods of posting avoidance are presented in an approximate hierarchy judged to return the greatest benefit for the least cost or effort for Florida bridges. This hierarchy is not absolute and may change depending on the particular bridge being load rated.

Load rating must be performed in accordance with this *Manual*. A specification based load rating for the entire bridge using a common specification either *LRFR (Part A)* or *LRFR (Part B)* is required. Posting avoidance techniques may be used as follows:

1. Posting avoidance techniques are to be used to avoid weight limit posting, when appropriate, to extend the useful life of a bridge until strengthening or replacement of the bridge is planned and executed.
2. Posting avoidance techniques are not to be used when load rating a new

bridge or when performing widening or rehabilitation. Posting avoidance techniques require either a Variation or an Exception as defined in the **PPM**. For bridges where the owner is a local government, concurrence from the bridge owner is required before variations or exceptions are processed by FDOT.

### **7.2.1 –Dynamic Load Allowance (IM) for Improved Surface Conditions (Variance)**

Using field observations and engineering judgment for spans greater than 40 feet, the Dynamic Load Allowance may be reduced if the following conditions exist:

1. Where the bridge approach and the bridge have a smooth transition and where there are minor surface imperfections or depressions, the Dynamic Load Allowance (IM) may be reduced to 20%.
2. Where there is a smooth riding surface on the bridge and where the transitions from the bridge approaches to the bridge deck across the expansion joints are smooth, the Dynamic Load Allowance (IM) may be reduced to 10%. (An example of this would be a deck slab finished by grinding and grooving to remove irregularities with no bumps or steps at expansion joints).

### **7.2.2 Approximate and Refined Methods of Analysis (Variance)**

When using an approximate method of structural analysis (code defined live load distribution **LRFD** 4.6.2), a rating factor as low as 0.95 can be rounded up to 1.0.

Refined methods of structural analyses, as discussed in Section 6A.3.3, may be performed in order to establish an enhanced live load distribution and

improved load rating. For continuous post-tensioned concrete bridges, a more sophisticated analysis of this type does not eliminate the need for a time-dependent construction analysis to determine overall longitudinal effects from permanent loads (e.g. BD 2 analysis).

### **7.2.3 Shear Capacity by AASHTO LRFD for Segmental Box Girder Bridges (Variance)**

When calculated in accordance with the **AASHTO LRFD** 5.8.6, the shear capacity, at the strength limit state, is based upon an assumed crack angle of 45 degrees, and may lead to an unsatisfactory load rating. The assumed angle of crack may be reconsidered and the capacity recalculated according to the procedure in Appendix B of "**Volume 10A Load Rating Post-Tensioned Concrete Segmental Bridges**" (Dated Oct. 8, 2004).

### **7.2.4 Existing Bridge Inventory Before January 2005 (Variance)**

If the bridge load carrying capacity as determined by Service III Limit State is causing unusual hardship and the current bridge inspection is showing no signs of either shear or flexural cracking, the capacity established for load posting and overweight vehicle permitting can be established using Strength Limit State.

### **7.2.5 Principal Tension – Segmental Concrete Bridges (Box Girders) (Variance)**

To calculate a crack angle more exactly than the assumed 45 degree angle use the specifications, use the procedure found in Appendix B of "**Volume 10 A Load Rating Post-Tensioned Concrete Segmental Bridges**" (dated Oct. 8, 2004) found on the Structures Design Office internet web site.

### **7.2.6 Stiffness of Traffic Barrier (Exception)**

Barrier stiffness should be considered and appropriately included if necessary. Inclusion of the barriers acting compositely with the deck slab and beams should improve longitudinal load ratings. When barriers are considered in this manner, the difference in the modulus of elasticity of the lower strength barrier concrete relative to that of the deck slab and to that of the beams should be taken into account. The presence of joints in a barrier reduces the overall effective section at the joint to that of the deck slab plus beam. This may result in a local concentration of longitudinal stress that should be appropriately considered. Nevertheless, load ratings should benefit from reasonable consideration of barrier stiffness.

### **7.2.7 Segmental Concrete Box Girder – Longitudinal Tension in Epoxy Joints (Exception)**

The **AASHTO Guide Specification for Segmental Bridges** and **LRFD** limit longitudinal tensile stresses to zero at epoxy match-cast joints under Service level conditions. The ability of the epoxy joint to accept tension is not considered. However, in properly prepared epoxy joints the bond usually exceeds the tensile strength of the concrete. Consequently, for posting avoidance, tensile stresses may be accepted as a function of the location and quality of the epoxy joint:

- For top fiber stresses on the roadway surface – no tension is permitted for all load rating calculations.
- For bottom fiber stresses –
  - a. Allow 200 psi tension at good quality epoxy joints (i.e. no leaks and fully sealed).

- b. No tension allowed for poor quality epoxy joints (i.e. leaky or not filled, gaps).

### **7.2.8 Transverse Tensile Stress Limit in Top Slab (Exception)**

The permissible tensile stress in a transversely post-tensioned slab is set at  $6.0\sqrt{f'_c}$ , regardless of the environment (FDOT Tables 6A.5.4.1-1 and 6A.6.4.1-1). For posting avoidance, up to  $7.5\sqrt{f'_c}$  may be allowed providing that:

- a. There is sufficient bonded reinforcement to carry the calculated tensile force in the concrete computed on the assumption of an uncracked section at a stress of  $0.5f_y$ , and,
- b. It is verified by field inspection that there are no cracks in the bridge deck as a consequence of routine or historically heavy vehicular traffic.

### **7.2.9 Concrete Box Girder – Principal Tensile Stress (Exception)**

If the load rating based upon the limiting principal tensile stress at the neutral axis of the basic beam or composite section is not satisfactory, the rating factor with regard to principal tension may be taken as 1.00 providing that:

- a. There is no visible evidence of any representative cracking in the webs.
- b. The capacity is satisfactory under the required Strength Limit State.

However, if during field inspection, cracks are discovered at or near a critical section where, by calculation, the principal tensile stress is found to be less than the allowable, then further study is recommended to determine the origin of the cracks and their significance to normal

use of the structure. If possible, a check should be made of construction records to determine if there was any change of construction, temporary loads or support reactions that may have induced a significant but temporary local affect.

### **7.2.10 Reduced Structural (DC) Dead Load (Exception)**

A lower dead load factor may be considered in accordance with the following criteria. Under no circumstance should this load factor be less than 1.10. For the self weight determined by:

- a. Design Plan or Shop Drawing dimensions and assumed average density for concrete, reinforcement and embedded items:  $\gamma_{DC} = 1.25$ .
- b. As-built dimensions, deck slab thickness and build-up using concrete density determined from construction records, adjusted for weight of embedded reinforcing:  $\gamma_{DC} = 1.15$ .
- c. Actual beam weights measured during construction:  $\gamma_{DC} = 1.10$ .

Cases (b) and (c) may only be used providing that neither additional structural component (DC) nor superimposed dead loads (DW) has been added whose weight cannot be accurately ascertained.

In using either (a) or (b) above, and when it is known that the original design was based on an assumed density for normal concrete and that a check or investigation can verify that a bridge has been constructed with Florida Limerock, then the unit weight may be reduced to 138 lbs per cubic foot for the concrete plus an allowance for the weight of steel.

### **7.3 Procedures for Posting of Weight Restrictions on Department Maintained Structures**

If load rating calculations indicate that any of the Florida legal loads have an Operating Rating level less than 1.0, then the bridge must be posted for weight. A load test may be performed to determine if the actual stress levels induced by Florida legal loads are in excess of the operating rating stresses.

When weight restrictions on Department maintained structures are required, the following procedure shall be followed:

- A. To initiate weight limit restrictions, the recommendations shall be developed by the District Structures Maintenance Engineer and endorsed by the District Maintenance Engineer.
- B. The request for weight limit restrictions, load rating calculations, the load rating summary sheet, computer output or load test results and sign configuration are to be submitted to the Engineer of Maintenance Operations for processing through the Director of the Office of Maintenance to the Secretary of the Department of Transportation for approval. The recommendations should be accompanied by the following:
  1. an explanation of the cause of the low rating
  2. what repairs are planned
  3. when the repairs will be performed
  4. will the repairs be performed by state forces or by contract
  5. the cost of repairs
  6. if and when the bridge is scheduled for rehabilitation or replacement

7. what effect posting the bridge will have on local traffic and emergency vehicles, including detour routes for affected vehicles
- C. Upon approval of the weight limit restrictions, the District Traffic Operations Engineer and the State Bridge Evaluation Engineer shall be sent a copy of these restrictions. The District Traffic Operations Office shall notify the appropriate local governments that a weight limit regulation has been approved.
  - D. A request for removal of weight limit restrictions shall be initiated by the District Structures Maintenance Engineer with the District Maintenance Engineer's approval. This request should indicate that the structure has been restored to legal load capacity. This request must be sent to the Engineer of Maintenance Operations for review. Before processing the request, the Office of Maintenance may perform a review of the load rating. Removal of weight limit restrictions must have the approval of the Secretary of the Department of Transportation, prior to removal of posting signs.
  - E. If the bridge is permanently taken out of service, then the District Structures Maintenance Engineer must notify the Engineer of Maintenance Operations in writing of this occurrence so that the Office of Maintenance removes the bridge from the list of posted bridges. The Road Use Permits Office shall be notified that the bridge has been permanently removed from service.
  - F. Weight limits to be shown on the posting signs at a bridge site, shall represent the gross vehicular weight (GVW) in tons for a maximum of three

truck types. However, no more than one or two truck symbols may be needed. Bridge capacity is calculated for the SU4, C5 & ST5 trucks. A graphic depiction of the general weight limit is shown on the Standard Index No. 17357. The three truck types are as follows:

1. Single unit trucks.(SU2, SU3 or SU4)
2. Combination trucks with a single trailer. (C3, C4 or C5)
3. Combination trucks with two trailers or a single unit truck with one trailer. (ST5)

G. The following are the requirements for weight limit signs:

1. The location and construction of weight limit posting signs shall be in accordance with the Design Standard Index No. 17357. This standard index has been prepared to meet or exceed the requirement established in Section 2B-41 of the Manual on Uniform Traffic Control Devices.
2. After approval of the weight limit restrictions by the Secretary of the Department of Transportation, the District Maintenance Engineer shall solicit the recommendations of the District Traffic Operations Engineer for sign location and design.
3. After receiving the District Traffic Operations Engineer's recommendations, the District Maintenance Engineer shall order the signs from the sign shop and direct the sign crew to immediately install them upon receipt.

H. Bona Fide Emergencies: In case of bona fide emergencies, the District

Maintenance Engineer shall take the necessary steps to protect the public safety. Corrective action may be initiated while seeking approval of weight limit posting. Such action may consist of restricting the traffic to certain lanes or posting the structure for no trucks or only trucks below a specified gross weight, while analysis and or repairs are performed and the official request is prepared and sent to the Engineer of Maintenance Operations. The Office of Maintenance and the Overweight/Oversized Permit Office should be notified in writing of these temporary restrictions as well as the time the restrictions are lifted or modified.

- I. The bridge file should contain all pertinent information concerning posting and removal of posting actions.

#### **7.4 Procedures for Posting Weight Restrictions on Local Government Structures**

Local government agencies are responsible for load posting of their structures. The Department, or its consultant, may load rate local government structures. When local government structures require weight restrictions the following procedure shall be followed:

- A. The Department, or its consultant, will develop recommendations for weight restrictions and notify the Department's local government bridge inspection project manager.
- B. The project manager will send the recommendations for weight restrictions to the local government agency. The agency will be required to perform the necessary actions to

post the structure. The agency may elect to use their own forces or hire a consultant engineer to perform additional testing and analysis as described in Section 6 of this **Manual**.

- C. The local government agency should respond to the weight restrictions recommendations by posting the structure as recommended, or commencing further testing and analysis. The Department should be notified of the agency's action within 30 days of receipt of the weight restriction recommendations. If further testing or analysis is to be performed this should be accomplished and the results should be reported to the Department within 90 days of first notifications.
- D. The Department should be kept informed of all posting actions accomplished by the local government agency. This should include copies of all calculations and testing results.
- E. Weight limit signs shall conform to the requirements stated in this **Manual**. Exceptions to these requirements may be approved by the project manager on a case by case basis.

## 8 LOAD TESTING OF BRIDGES

### 8.1 General

FDOT generally uses proof load testing as described in article 8.8.3 of the *MBE*. If this methodology is not used, then Table 8.8.2.3.1-1 shall establish the magnitude of the benefit.

When a load test has been performed on a structure the load ratings determined by the load test should be entered in the database.

Analysis methods by their very nature represent engineering approximations of the stresses in a structure. Assumptions are made at every step of the analysis process. For example, a steel girder without shear connectors is assumed to act non-compositely with the concrete deck. Experiments have shown that a girder without shear connectors will have a portion of the composite action of a girder with shear connectors. Stiffness provided to the deck by concrete barriers aids in distributing live load. The cumulative effects of these assumptions may result in actual safe load carrying capacity to be significantly larger than that calculated by analysis. These conservative assumptions are generally good in that they provide a safe conservative approach and simplify the analysis. For some critical structures, it may be desirable to establish a higher safe load carrying capacity. The following types of structures are candidates for load testing:

- A. Bridges that restrict the flow of overweight vehicles.
- B. Bridges that are posted for weight restrictions.
- C. Bridges that are difficult to analyze.

### C8.1

The load test procedure is a process where a structure is instrumented and then subjected to a known test load which is progressively increased. This determines the safe carrying capacity by measuring the actual load the structure can carry without distress. Since even the most sophisticated analysis contains assumptions, this method is the most accurate. However, the process is expensive and time consuming and therefore should be selected judiciously. For a structure to be load tested it must be on the load test candidate list.

- D. Bridges for which plans are not available.

## **8.2 Load Test Candidate**

Periodically, the State Bridge Evaluation Engineer in coordination with the District Structures Maintenance Engineers will develop a list of candidate bridges for load testing. Following is the process for the development of the load test candidate list.

- A. The District Structures Maintenance Engineers will develop a list of bridges for load testing.
- B. The District Structures Maintenance Engineer should assign a priority order to this list and submit the list to the Bridge Evaluation Engineer who will compile a statewide list of bridges to be load tested, possibly adding bridges to the list considering routing and permitting requirements.
- C. The Bridge Evaluation Engineer will send the statewide list to the Structures Research Center.
- D. The Structures Research Center will schedule the load tests with the Districts using the established priority ranking modified to reduce travel time from site-to-site.
- E. The Structures Research Center will send the load test report within 60 days of completion of the field load test to the District Structures Maintenance Engineer with copies to the State Bridge Evaluation Engineer. If it is anticipated that the evaluation requires more time due to the complexity of the analyses performed, the Structures Research Center will provide a written notification to the Office of Maintenance including the anticipated date until completion.

- F. The District Structures Maintenance Engineer will within 14 days enter the ratings from the load test reports into the database and Section D (Load Rating) of the Bridge Record.

### 8.3 Load Test Reports

Load Tests shall be performed in conformance with the direction provided in the current version of the "*Structures Manual*". The Structures Research Center will verify that the load tested span(s) control the load rating for the structure. Results should be obtained for a single lane loaded and then 2 lanes loaded simultaneously. The results obtained for single versus double lane loadings are important for permitting decisions. If a load test is performed on a bridge having a twin structure, the Research Center will state if the results apply to both structures. The load test report should at a minimum contain the following information, determined during the load test or assumed during the analysis of data gathered during the load test:

- A. Date load test performed.
- B. Brief description of bridge and condition.
- C. Controlling span and length.
- D. Rating controlled by shear, positive moment, or negative moment or other.
- E. Controlling element.
- F. Impact factor or Dynamic Load Allowance.
- G. Live load distribution factor.
- H. Truck(s) used for load test.
- I. General assumptions made.
- J. Load test static or dynamic.

- K. Available live load moment and shear.
- L. Applied moment and shear.
- M. Ratings for HS20 vehicle(s) as well as HL93 vehicle(s) and all Florida legal trucks.
- N. Longitudinal location of controlling axle. For GFS (Girder – Floor Beam - Stringer) systems as well as for transversely post-tensioned bridge decks, transverse location of controlling axles.
- O. Signature and Seal of the professional engineer performing the load test.

## 9 PERMITTING OPERATIONS

One of the most important internal recipients of the load rating information is the Road Use Permit Office which issues permits for overweight-over dimensional vehicles. The traveling public, as well as the commercial trucking industry, are directly impacted by the load rating values in the Pontis database. Based upon this Pontis information, the Office of Maintenance is responsible to make decisions about safe level of permit truck weight allowed to cross the current bridge inventory.

However, to facilitate the mobility of certain types of vehicles and moves, the Office of Maintenance consults with the Districts to determine potential conflicts of a temporary nature. Examples of such conflict are:

- A. Temporary clearance restriction(s) due to widening.
- B. Time of movement occurring during higher levels of daily traffic.
- C. Local event generating an unusual level of traffic The District Maintenance Engineers have designated a single contact person (and a back-up person) to coordinate comments provided on specific moves.

To allow the Permit Office to route vehicles over the inventoried routes, each District office shall provide to the permit office detailed “bridge” maps indicating the location and the number for each bridge included within the District. Each District shall provide to the permit office a set of 2 hard copies of those bridge maps until an electronic format is feasible. Updates to these maps should be provided at least every year.

## 10 SUMMARY OF RATINGS

After the structure has been load rated, the “Load Rating Summary Tables” shall be completed, placed in Section D of the Bridge Record File and included in the contract plans (if applicable). The tables are shown in the Appendix of this *Manual* and are available in the Department’s Forms Library.

Instructions for completing the Load Rating Summary Tables:

- A. Determine the appropriate summary table to use.
- B. Fill in the date in General Note number 1.
- C. Answer questions in the table notes section where applicable. For prestressed members, modify notes to state the applicable tensile stress limit.
- D. Enter all data in the summary tables corresponding to the vehicle type or axle weight for both the longitudinal and transverse capacities. Transverse capacities are generally not required except for transversely post-tensioned deck slabs. Capacities for vehicles SU4, C5 and ST5 do not have to be calculated if the operating rating for HL-93 is equal to or greater than 1.4.
- E. Enter the span length of the member measured center-line to center-line bearing.
- F. In the comments section, state whether the rating is for bending strength, bending stress, shear strength or principal tension stress.
- G. Enter all additional comments as required to clarify the load capacity calculations.

- H. Modify the rating location sketch by dimensioning the span lengths to resemble the bridge being rated and labeling the locations of the ratings.
- I. Fill out the data for the Controlling Load Rating in the table adjacent to the rating location sketch.
- J. The responsible engineer will sign and seal the "Load Rating Summary Table".
- K. During the transition, software, procedures and manual have to be updated. Temporarily, if the **LRFR** rating result for HL93 (Design Inventory and operating levels) is expressed as a factor, the value entered in the bridge database (Pontis) should be the rating factor multiplied by 36 tons. If the results are already expressed as tonnage, enter directly the value obtained into the bridge database. The value for the FL120 should be entered as soon as the field is available in the bridge database. It is paramount that the proper rating method be accurately included in the bridge database. Error in the input may generate bridge overloading.

## **Appendix A - LOAD RATING SUMMARY TABLES**

### **Table of Contents**

<u>Page No.</u>	<u>Title – LRFR Load Rating Summary Table</u>
A-2	Post-Tensioned Concrete Box Girder Bridges
A-3	Reinforced Concrete Bridges
A-4	Prestressed Concrete Bridges
A-5	Continuous Post-Tensioned I-Girder Bridges
A-6	Steel Girder Bridges
A-7	Reinforced Concrete Bridge Culverts

Load Rating Summary Details for Post-Tensioned Concrete Box Girder Bridges

Table Date 08-01-10

Table 1 - LRFR using Part A

Level	Direction	Limit State	Vehicle	Weight (tons)	Load Factors						Moment (Strength) or Stress (Service)					Shear (Strength)					Comments: Interior/exterior beam DF method if other than LRFD. Other appropriate comments			
					DC	DW	EL	FR	TU CR SH	TG	LL	Distribution Factor (DF)	Rating Factor	Tons	Location	Dimension	Distribution Factor (DF)	Rating Factor	Tons	Location		Dimension		
Design Load Rating	Longitudinal	Strength I (Inv)	HL-93	N/A	1.25	1.50	1.00	1.00	0.50	N/A	1.75			N/A					N/A					
		Strength I (Op)	HL-93	N/A	1.25	1.50	1.00	1.00	0.50	N/A	1.35			N/A					N/A					
		Service III (Inv)	HL-93	N/A	1.00	1.00	1.00	1.00	1.00	0.50	0.80					N/A	N/A	N/A	N/A	N/A	N/A	N/A	N/A	
		Service III (Op)	HL-93	N/A	1.00	1.00	1.00	1.00	1.00	1.00	N/A	1.0 SL					N/A	N/A	N/A	N/A	N/A	N/A	N/A	
	Transverse	Strength I (Inv)	single axle	16.0	1.25	1.50	1.00	N/A	N/A	N/A	1.75					N/A	N/A	N/A	N/A	N/A	N/A	N/A		
		Strength I (Inv)	tandem axle	25.0	1.25	1.50	1.00	N/A	N/A	N/A	1.75					N/A	N/A	N/A	N/A	N/A	N/A	N/A		
		Strength I (Op)	single axle	16.0	1.25	1.50	1.00	N/A	N/A	N/A	1.35					N/A	N/A	N/A	N/A	N/A	N/A	N/A		
		Strength I (Op)	tandem axle	25.0	1.25	1.50	1.00	N/A	N/A	N/A	1.35					N/A	N/A	N/A	N/A	N/A	N/A	N/A		
		Service I (Inv)	single axle	16.0	1.00	1.00	1.00	N/A	N/A	N/A	1.00					N/A	N/A	N/A	N/A	N/A	N/A	N/A		
		Service I (Inv)	tandem axle	25.0	1.00	1.00	1.00	N/A	N/A	N/A	1.00					N/A	N/A	N/A	N/A	N/A	N/A	N/A		
		Service I (Op)	single axle	16.0	1.00	1.00	1.00	N/A	N/A	N/A	1.00					N/A	N/A	N/A	N/A	N/A	N/A	N/A		
		Service I (Op)	tandem axle	25.0	1.00	1.00	1.00	N/A	N/A	N/A	1.00					N/A	N/A	N/A	N/A	N/A	N/A	N/A		
Legal Load Rating	Longitudinal	Strength I	SU4	35.0	1.25	1.50	1.00	1.00	0.50	N/A	1.35													
		Strength I	C5	40.0	1.25	1.50	1.00	1.00	0.50	N/A	1.35													
		Strength I	ST5	40.0	1.25	1.50	1.00	1.00	0.50	N/A	1.35													
		Service III	SU4	35.0	1.00	1.00	1.00	1.00	1.00	N/A	1.0 SL					N/A	N/A	N/A	N/A	N/A	N/A	N/A		
		Service III	C5	40.0	1.00	1.00	1.00	1.00	1.00	N/A	1.0 SL					N/A	N/A	N/A	N/A	N/A	N/A	N/A		
		Service III	ST5	40.0	1.00	1.00	1.00	1.00	1.00	N/A	1.0 SL					N/A	N/A	N/A	N/A	N/A	N/A	N/A		
Permit Load Rating	Longitudinal	Strength II	FL120	60.0	1.25	1.50	1.00	1.00	0.50	N/A	1.35													
		Service III	FL120	60.0	1.00	1.00	1.00	1.00	1.00	N/A	0.9 SL					N/A	N/A	N/A	N/A	N/A	N/A			

Abbreviations:  
 Inv - Inventory  
 Op - Operating  
 SL - Striped Lanes

NOTES

General Notes:

1. This table is based on the requirements established in the January 2xxx "Structures Manual".
2. Permit capacity is determined by using the permit vehicle in all lanes.
3. If the Design Operating Load Rating is greater than 1.4, Load Rating using Legal Vehicles SU4, C5, and ST5 is not required.
4. Service III tensile stress limit =  $3\sqrt{f'_c}$  or  $6\sqrt{f'_c}$ ; Service III principal tension stress limit =  $3.5\sqrt{f'_c}$ .
5. Service I Transverse Design Inventory tensile stress limit =  $3\sqrt{f'_c}$  or  $6\sqrt{f'_c}$ ; Service I Transverse Design Operating tensile stress limit =  $6\sqrt{f'_c}$ .

Notes to Designer:

1. Modify or place the Rating Location sketch Showing Span Length(s) to resemble the bridge being rated.
2. Fill in the date in General Note number 1 above.
3. In the comments section for Service Limit III, state whether the rating is for principal tension stress or bending stress.

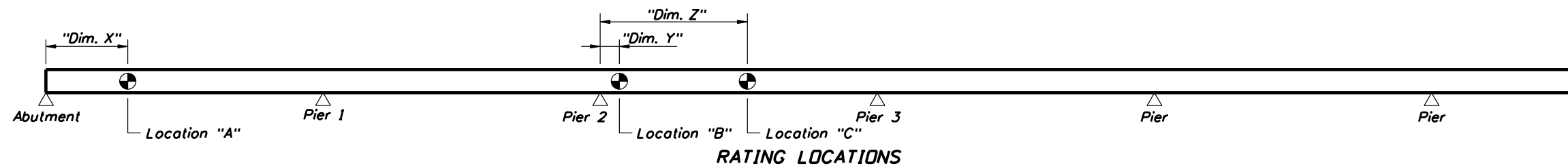
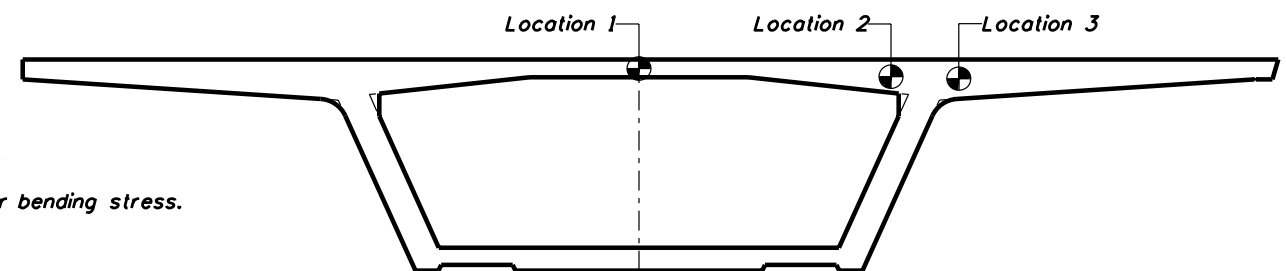

Controlling Load Rating			
Limit State	Vehicle	Weight (Tons)	Rating Factor

Load Rating Summary Details for Reinforced Concrete Bridges															Table Date 08-01-10	
Table 1 - LRFR using Part B <sup>3</sup>																
Level	Vehicle	Weight (tons)	Load Factors		Moment (Strength)					Shear (Strength)					Comments:	
			LL	DL	Distribution Factor (DF)	Rating Factor	Tons	Location	Dimension	Distribution Factor (DF)	Rating Factor	Tons	Location	Dimension		
Inventory	HS-20	36.0	2.17	1.30												
Operating	HS-20	36.0	1.30	1.30												
	SU4	35.0	1.30	1.30												
	C5	40.0	1.30	1.30												
	ST5	40.0	1.30	1.30												

General Notes:  
 1. This table is based on the requirements established in the January 2xxx "Structures Manual".

Table 2 Notes:  
 1. Permit capacity is determined by using the permit vehicle in all lanes.  
 2. If the Design Operating Load Rating is greater than 1.4, Load Rating using Legal Vehicles SU4, C5, and ST5 is not required.  
 3. Has the AASHTO LRFD Specifications Article 5.8.3.5 longitudinal reinforcement been satisfied?  Yes  No

Notes to Designer:  
 1. Modify or replace the Rating Location sketch Showing Span Length(s) to resemble the bridge being rated.  
 2. Fill in the date in General Note number 1 above.  
 3. See the "Bridge Load Rating Manual" for appropriate rating methods.

Load Rating Summary Details for Reinforced Concrete Bridges															Table Date 08-01-10		
Table 2 - LRFR using Part A <sup>3</sup>																	
Level	Limit State	Vehicle	Weight (tons)	Load Factors			Moment (Strength)					Shear (Strength)					Comments:
				LL	DC	DW	Distribution Factor (DF)	Rating Factor	Tons	Location	Dimension	Distribution Factor (DF)	Rating Factor	Tons	Location	Dimension	
Design Load Rating	Strength I (Inv)	HL-93	N/A	1.75	1.25	1.50											
	Strength I (Op)	HL-93	N/A	1.35	1.25	1.50											
Legal Load Rating	Strength I	SU4	35.0	1.35	1.25	1.50											
	Strength I	C5	40.0	1.35	1.25	1.50											
	Strength I	ST5	40.0	1.35	1.25	1.50											
Permit Load Rating	Strength II	FL120	60.0	1.35	1.25	1.50											

Abbreviations:  
 Inv - Inventory  
 Op - Operating

Controlling Load Rating			
Limit State	Vehicle	Weight (Tons)	Rating Factor

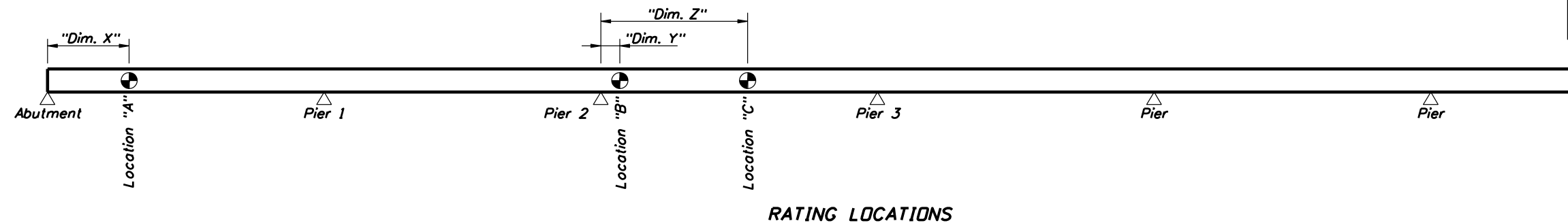

**Load Rating Summary Details for Prestressed Concrete Bridges (Flat Slab and Deck/Girder)** Table Date 08-01-10

**Table 1 - LRFR using Part B<sup>3</sup>**

Level	Vehicle	Weight (tons)	Load Factors		Moment (Strength) or Stress (Service)					Shear (Strength)					Comments:	
			LL	DL	Distribution Factor (DF)	Rating Factor	Tons	Location	Dimension	Distribution Factor (DF)	Rating Factor	Tons	Location	Dimension		
Inventory (Strength)	HS-20	36.0	2.17	1.30												
Inventory (Service)	HS-20	36.0	1.0	1.0						N/A	N/A	N/A	N/A	N/A		
Operating (Strength)	HS-20	36.0	1.30	1.30												
	SU4	35.0	1.30	1.30												
	C5	40.0	1.30	1.30												
	ST5	40.0	1.30	1.30												
Operating (Service)	HS-20	36.0	1.0	1.0						N/A	N/A	N/A	N/A	N/A		

**General Notes:**

1. This table is based on the requirements established in the January 2xxx "Structures Manual".

**Table 2 Notes:**

1. Permit capacity is determined by using the permit vehicle in all lanes.
2. If the Design Operating Load Rating is greater than 1.4, Load Rating using Legal Vehicles SU4, C5, and ST5 is not required.
3. Service III Design Inventory tensile stress limits =  $3\sqrt{f'c}$  or  $6\sqrt{f'c}$ . Service III Design Operating, Legal, and Permit tensile stress limits =  $7.5\sqrt{f'c}$ .
4. Has the AASHTO LRFD Specifications Article 5.8.3.5 longitudinal reinforcement been satisfied?  Yes  No

**Notes to Designer:**

1. Modify or replace the Rating Location sketch Showing Span Length(s) to resemble the bridge being rated.
2. Fill in the date in General Note number 1 above.
3. See the "Bridge Load Rating Manual" for appropriate rating methods.

**Load Rating Summary Details for Prestressed Concrete Bridges (Flat Slab and Deck/Girder)** Table Date 08-01-10

**Table 2 - LRFR using Part A<sup>3</sup>**

Level	Limit State	Vehicle	Weight (tons)	Load Factors			Moment (Strength) or Stress (Service)					Shear (Strength)					Comments:
				LL	DC	DW	Distribution Factor (DF)	Rating Factor	Tons	Location	Dimension	Distribution Factor (DF)	Rating Factor	Tons	Location	Dimension	
Design Load Rating	Strength I (Inv)	HL-93	N/A	1.75	1.25	1.50			N/A						N/A		
	Strength I (Op)	HL-93	N/A	1.35	1.25	1.50			N/A						N/A		
	Service III (Inv)	HL-93	N/A	0.80	1.00	1.00			N/A						N/A	N/A	N/A
	Service III (Op)	HL-93	N/A	0.80	1.00	1.00			N/A						N/A	N/A	N/A
Legal Load Rating	Strength I	SU4	35.0	1.35	1.25	1.50											
	Strength I	C5	40.0	1.35	1.25	1.50											
	Strength I	ST5	40.0	1.35	1.25	1.50											
	Service III	SU4	35.0	0.80	1.00	1.00									N/A	N/A	N/A
	Service III	C5	40.0	0.80	1.00	1.00									N/A	N/A	N/A
	Service III	ST5	40.0	0.80	1.00	1.00									N/A	N/A	N/A
Permit Load Rating	Strength II	FL120	60.0	1.35	1.25	1.50											
	Service III	FL120	60.0	0.70	1.00	1.00									N/A	N/A	N/A

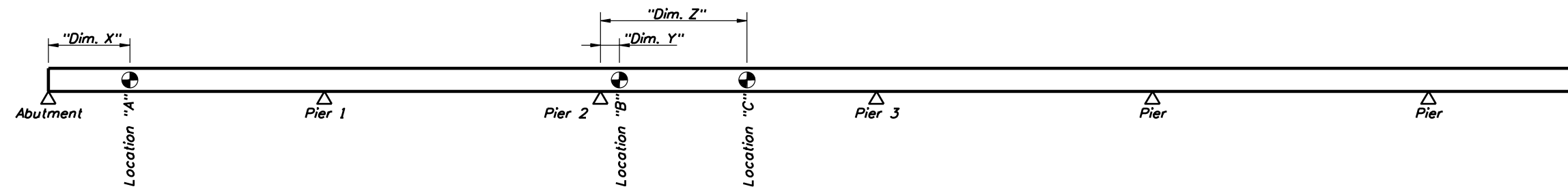

**RATING LOCATIONS**

**Abbreviations:**

- Inv - Inventory
- Op - Operating

Controlling Load Rating			
Limit State	Vehicle	Weight (Tons)	Rating Factor

Load Rating Summary Details for Continuous Post-Tensioned I-Girder Bridges

Table Date 08-01-10

Table 1 - LRFR using Part A

Level	Limit State	Vehicle	Weight (tons)	Load Factors							Moment (Strength) or Stress (Service)					Shear (Strength)				Comments: Interior/exterior beam DF method if other than LRFD. Other appropriate comments	
				DC	DW	EL	FR	TU CR SH	TG	LL	Distribution Factor (DF)	Rating Factor	Tons	Location	Dimension	Distribution Factor (DF)	Rating Factor	Tons	Location		Dimension
Design Load Rating	Strength I (Inv)	HL-93	N/A	1.25	1.50	1.00	1.00	0.50	N/A	1.75			N/A					N/A			
	Strength I (Op)	HL-93	N/A	1.25	1.50	1.00	1.00	0.50	N/A	1.35			N/A					N/A			
	Service III (Inv)	HL-93	N/A	1.00	1.00	1.00	1.00	1.00	0.50	0.8					N/A	N/A	N/A	N/A	N/A	N/A	N/A
	Service III (Op)	HL-93	N/A	1.00	1.00	1.00	1.00	1.00	1.00	N/A	0.8				N/A	N/A	N/A	N/A	N/A	N/A	N/A
Legal Load Rating	Strength I	SU4	35.0	1.25	1.50	1.00	1.00	0.50	N/A	1.35											
	Strength I	C5	40.0	1.25	1.50	1.00	1.00	0.50	N/A	1.35											
	Strength I	ST5	40.0	1.25	1.50	1.00	1.00	0.50	N/A	1.35											
	Service III	SU4	35.0	1.00	1.00	1.00	1.00	1.00	N/A	0.8					N/A	N/A	N/A	N/A	N/A	N/A	N/A
	Service III	C5	40.0	1.00	1.00	1.00	1.00	1.00	N/A	0.8					N/A	N/A	N/A	N/A	N/A	N/A	N/A
	Service III	ST5	40.0	1.00	1.00	1.00	1.00	1.00	N/A	0.8					N/A	N/A	N/A	N/A	N/A	N/A	N/A
Permit Load Rating	Strength II	FL120	60.0	1.25	1.50	1.00	1.00	0.50	N/A	1.35											
	Service III	FL120	60.0	1.00	1.00	1.00	1.00	1.00	N/A	0.7					N/A	N/A	N/A	N/A	N/A	N/A	N/A

Abbreviations:

- Inv - Inventory
- Op - Operating

NOTES

General Notes:

1. This table is based on the requirements established in the January 2xxx "Structures Manual".
2. Permit capacity is determined by using the permit vehicle in all lanes.
3. If the Design Operating Load Rating is greater than 1.4, Load Rating using Legal Vehicles SU4, C5, and ST5 is not required.
4. Service III Design Inventory tensile stress limit =  $3\sqrt{f'_c}$  or  $6\sqrt{f'_c}$ ; Service III Design Operating, Legal, and Permit tensile stress limit =  $7.5\sqrt{f'_c}$ .
5. Has the AASHTO LRFD Specifications Article 5.8.3.5 longitudinal reinforcement been satisfied?  Yes  No

Notes to Designer:

1. Modify or replace the Rating Location sketch Showing Span Length(s) to resemble the bridge being rated.
2. Fill in the date in General Note number 1 above.

Controlling Load Rating			
Limit State	Vehicle	Weight (Tons)	Rating Factor

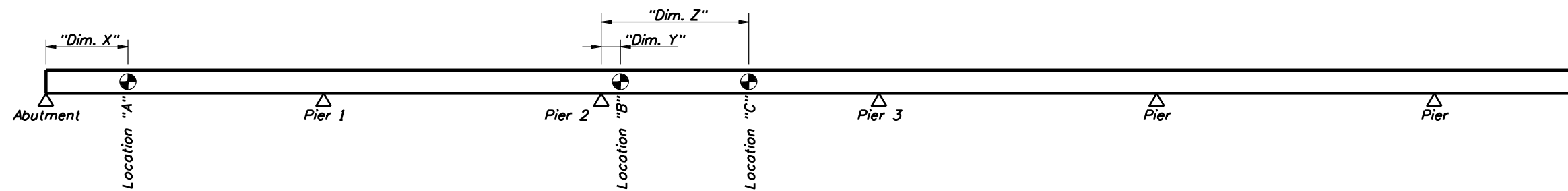

RATING LOCATIONS

**Load Rating Summary Details for Steel Girder Bridges** Table Date 08-01-10

**Table 1 - LRFR using Part B<sup>5</sup>**

Level	Vehicle	Weight (tons)	Load Factors		Moment (Strength)					Shear (Strength)					Comments:	
			LL	DL	Distribution Factor (DF)	Rating Factor	Tons	Location	Dimension	Distribution Factor (DF)	Rating Factor	Tons	Location	Dimension		
Inventory (Strength)	HS-20	36.0	2.17	1.30												Interior/exterior beam DF method if other than Standard Spec. Other appropriate comments
Operating (Strength)	HS-20	36.0	1.30	1.30												
	SU4	35.0	1.30	1.30												
	C5	40.0	1.30	1.30												
	ST5	40.0	1.30	1.30												

**General Notes:**

1. This table is based on the requirements established in the January 2xxx "Structures Manual".

**Table 2 Notes:**

1. Permit capacity is determined by using the permit vehicle in all lanes.  
2. If the Design Operating Load Rating is greater than 1.4, Load Rating using Legal Vehicles SU4, C5, and ST5 is not required.

**Notes to Designer:**

1. Modify or replace the Rating Location sketch Showing Span Lengths to resemble the bridge being rated.  
2. Fill in the date in General Note number 1 above.  
3. For Girder, Floorbeam, Stringer Bridges, use one Summary sheet for each member type."  
4. Design Service Limit State ratings are only required for compact members.  
5. See the "Bridge Load Rating Manual" for appropriate rating methods.  
6. Modify the tables to include transverse ratings in accordance with the "Bridge Load Rating Manual" if necessary.

**Load Rating Summary Details for Steel Girder Bridges** Table Date 08-01-10

**Table 2 - LRFR using Part A<sup>5</sup>**

Level	Limit State	Vehicle	Weight (tons)	Load Factors			Moment (Strength) or Stress (Service)					Shear (Strength)					Comments:
				LL	DC	DW	Distribution Factor (DF)	Rating Factor	Tons	Location	Dimension	Distribution Factor (DF)	Rating Factor	Tons	Location	Dimension	
Design Load Rating	Strength I (Inv)	HL-93	N/A	1.75	1.25	1.50			N/A						N/A		
	Strength I (Op)	HL-93	N/A	1.35	1.25	1.50			N/A						N/A		
	Service II (Inv) <sup>4</sup>	HL-93	N/A	1.30	1.00	1.00			N/A				N/A	N/A	N/A	N/A	N/A
	Service II (Op) <sup>4</sup>	HL-93	N/A	1.00	1.00	1.00			N/A				N/A	N/A	N/A	N/A	N/A
Legal Load Rating	Strength I	SU4	35.0	1.35	1.25	1.50											
	Strength I	C5	40.0	1.35	1.25	1.50											
	Strength I	ST5	40.0	1.35	1.25	1.50											
	Service II <sup>4</sup>	SU4	35.0	1.30	1.00	1.00							N/A	N/A	N/A	N/A	N/A
	Service II <sup>4</sup>	C5	40.0	1.30	1.00	1.00							N/A	N/A	N/A	N/A	N/A
	Service II <sup>4</sup>	ST5	40.0	1.30	1.00	1.00							N/A	N/A	N/A	N/A	N/A
Permit Load Rating	Strength II	FL120	60.0	1.35	1.25	1.50											
	Service II <sup>4</sup>	FL120	60.0	0.90	1.00	1.00									N/A	N/A	N/A

**Abbreviations:**

Inv - Inventory

Op - Operating

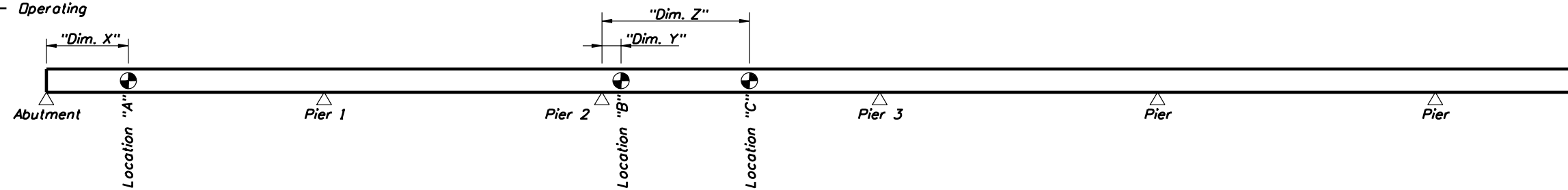

**RATING LOCATIONS**

Controlling Load Rating			
Limit State	Vehicle	Weight (Tons)	Rating Factor

**Load Rating Summary Details for Reinforced Concrete Bridge Culverts (Box and Three-Sided Culvert)** Table Date 08-01-10

**Table 1 - LRFR using Part B<sup>3</sup>**

Level	Vehicle	Weight (tons)	Load Factors		Moment (Strength)					Shear (Strength)					Comments:	
			LL	DL	Unfactored Ratio LL / DL	Rating Factor	Tons	Location	Dimension	Unfactored Ratio LL / DL	Rating Factor	Tons	Location	Dimension		
Inventory	HS-20	36.0	2.17	1.30												
Operating	HS-20	36.0	1.30	1.30												
	SU4	35.0	1.30	1.30												
	C5	40.0	1.30	1.30												
	ST5	40.0	1.30	1.30												

**General Notes:**  
 1. This table is based on the requirements established in the January 2xxx "Structures Manual".

**Table 2 Notes:**  
 1. Permit capacity is determined by using the permit vehicle in all lanes.  
 2. If the Design Operating Load Rating is greater than 1.4, Load Rating using Legal Vehicles SU4, C5, and ST5 is not required.  
 3. Does the depth of fill above the top slab exceed the span length between the inside faces of the end walls (Bridge Culvert Total Span Length)?  Yes  No

If Yes then the live load may be neglected per LRFD 3.6.1.2.6.

**Load Rating Summary Details for Reinforced Concrete Bridges** Table Date 08-01-10

**Table 2 - LRFR using Part A<sup>3</sup>**

Level	Limit State	Vehicle	Weight (tons)	Load Factors			Moment (Strength)					Shear (Strength)					Comments:
				LL	DC	DW	Unfactored Ratio LL / (DC+DW)	Rating Factor	Tons	Location	Dimension	Unfactored Ratio LL / (DC+DW)	Rating Factor	Tons	Location	Dimension	
Design Load Rating	Strength I (Inv)	HL-93	N/A	1.75	1.25	1.50											
	Strength I (Op)	HL-93	N/A	1.35	1.25	1.50											
Legal Load Rating	Strength I	SU4	35.0	1.35	1.25	1.50											
	Strength I	C5	40.0	1.35	1.25	1.50											
	Strength I	ST5	40.0	1.35	1.25	1.50											
Permit Load Rating	Strength II	FL120	60.0	1.35	1.25	1.50											

**Notes to Designer:**  
 1. Modify or replace the Rating Location sketch Showing Span Length(s) to resemble the bridge culvert being rated.  
 2. Fill in the date in General Note number 1 above.  
 3. See the "Bridge Load Rating Manual" for appropriate rating methods.

- Abbreviations:**
- DL - Dead Load (LFD or ASD)
  - DC - Component Dead Load (LRFR)
  - DW - Wearing Surface & Utility Dead Load (LRFR)
  - LL - Live Load
  - Inv - Inventory
  - Op - Operating

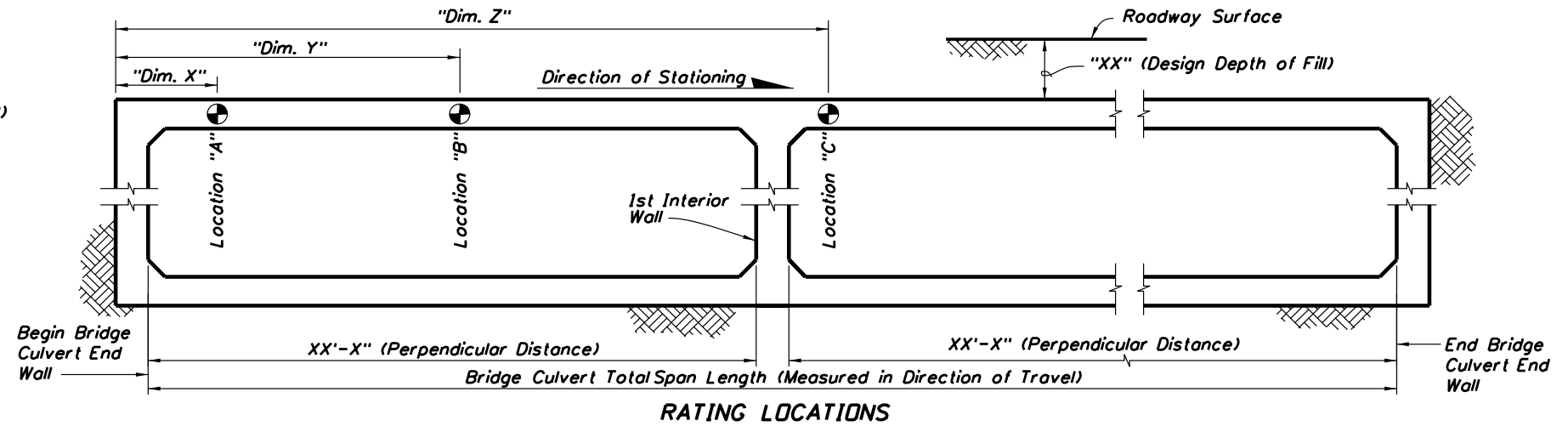

Limit State	Vehicle	Weight (Tons)	Rating Factor