

Orlando, FL

November 7-8, 2024



2024 TRANSPORTATION SYMPOSIUM

New Criteria for Straight Steel I-Girder (SSI-G) Bridges (aka SDB 24-01)



Dennis Golabek, PE

State Structures Design Office - GEC WSP

Objective: *NEW Criteria* - Analysis and Design

- Review Past and Current SDGs Criteria
- Background
- Five Cases
- Phase Construction and Widening Rules
- *Criteria Revisions* - Curved Steel I-G and Steel Boxes
- Procedure to Calculate the $ADTT_{SL}$

Straight Steel I-Girder (SSI-G)



SDB 24-01
June 11

Review Past and Current SDGs Criteria

- ❑ SDG allows both Approximate and Refined Methods of Analyses (as required).
- ❑ Historically, the Approximate Method (Line Girder Analysis) has produced efficient and robust designs.
- ❑ LRFD 4.6.2 Approximate Method of Analysis – allows for high skew angles.

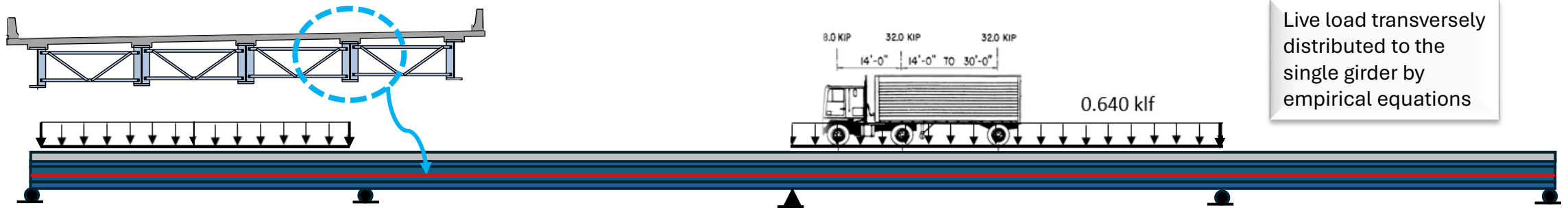

- ❑ LRFD 4.6.3 Refined Method of Analysis (RMA) - more expensive software and greater Design/LR effort.



- ❑ Some “design gaps” when using LGA

Review Past and Current SDGs Criteria

Method of Analysis determined by:

❖ Skew Angle (θ)

Up till 2017

❖ Skew Index (I_s)

2018 to Current

❖ θ , I_s , & CF-Configuration

SDB 24-01

Structures Design Guidelines
5 - Superstructure - Steel

Topic No. 625-020-018
January 2017

5 SUPERSTRUCTURE - STEEL

5.1 GENERAL (Rev. 01/17)

A. Level of analysis:

1. For straight bridges with one or more supports skewed greater than 20° , a grid, 3-D or finite element analysis is required considering the structure acting as a unit.

Structures Design Guidelines
5 - Superstructure - Steel

Topic No. 625-020-01b
January 2018

5 SUPERSTRUCTURE - STEEL

5.1 GENERAL (Rev. 01/18)

A. In addition to *LRFD* Section 4, use the following level of analysis for skewed steel I-girder units:

1. Use a Refined Method of Analysis [*LRFD* 4.6.3] if $0.2 < \text{LRFD bridge skew index} \leq 0.6$ (except as noted in No. 2 below).

Table 5.13.1-1 Design Criteria for Straight Steel I-Girder Units

Case	SDG Section	Skew Angle (θ)	Skew Index (I_s)	Cross-Frame Configuration	Required Method(s) of Analysis ³
------	-------------	-------------------------	----------------------	---------------------------	---

Background: Survey 2000-2014

$$I_s = \frac{w_g \tan \theta}{L_s}$$

Skew Index

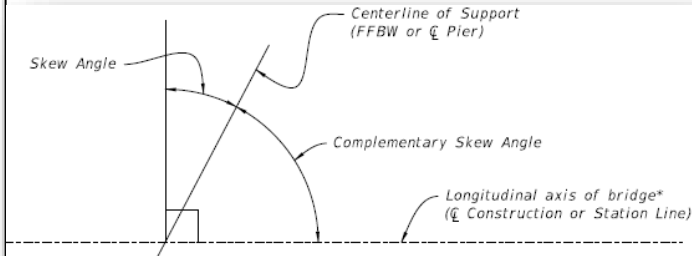
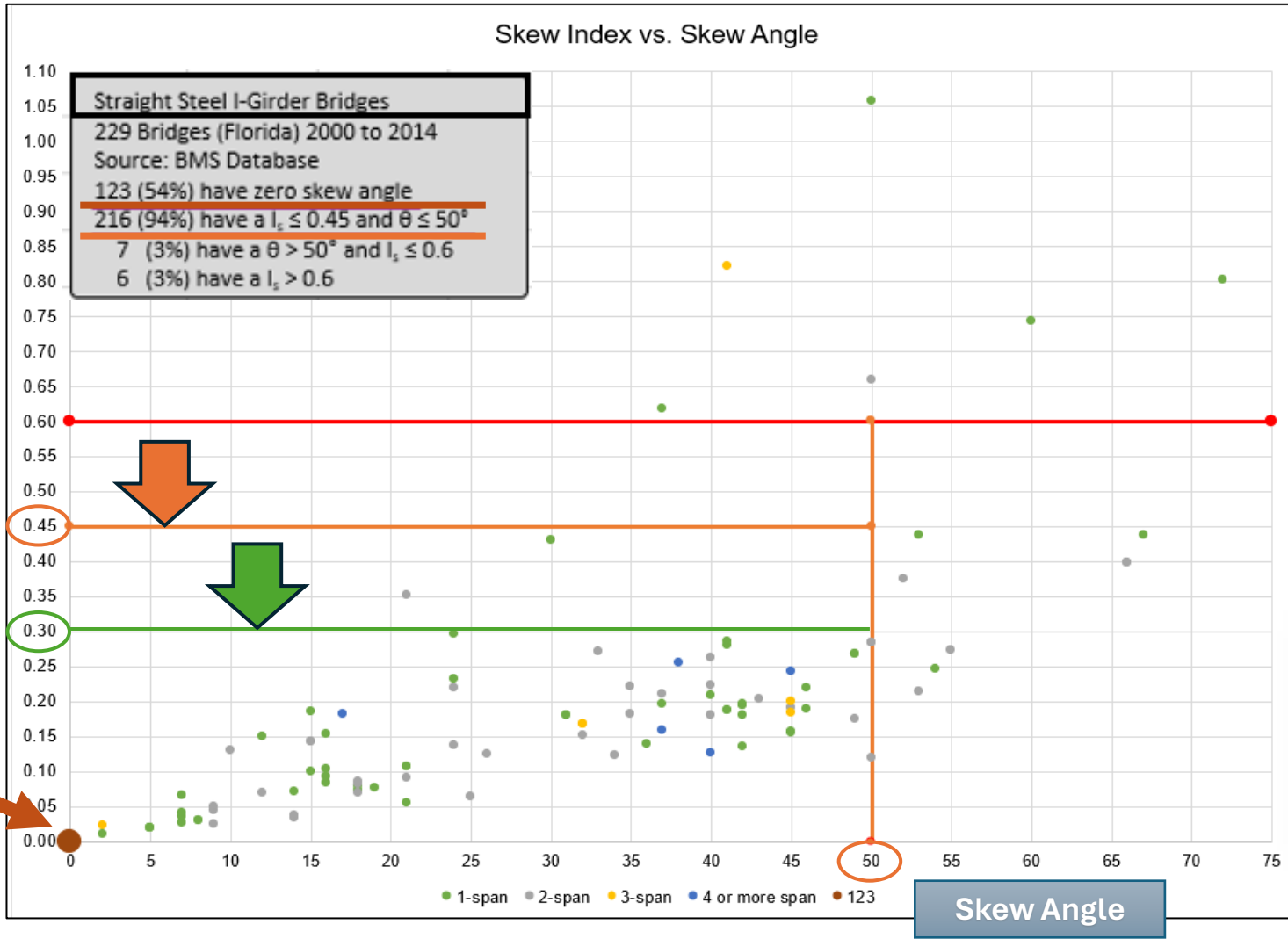

Background: FDOT Research Reports

- FDOT Research Report BE535 (~25 bridges) Established Cases based on skew angles, skew indexes and CF conf.
 - ❖ Case 1 and 2 can use a LGA and could estimate FLB stresses and cross-frame forces.
- FDOT Research Report BEB13 (~25 bridges) Focused on Cases 1 and 2.
- FDOT TWO (40 bridges) Focused on Case 2.

Girder Behavior (LGA vs. 3D-FEA)	Cases 1 & 2 Adjustment to LGA
STR I and SER II Bending Moments (Positive and Negative)	No
STR I and SER II Vertical Shear Forces	No
STR I Bearing Reactions for the Exterior Girder (obtuse corner & pier)	Yes, multiplicative factor for Case 2
Fatigue Vertical Shear Force Ranges	Yes, multiplicative factor for Case 2
Fatigue Flexural Stresses for Exterior Girder	Yes, new LLDF equation (FDOT)
Total Dead Load Vertical Displacements	No
Live Load Deflections	Yes, use LLDF for moments
Girder Layovers under the total dead load	Simplified EQN

Background: Agenda Item 37

2021 AASHTO BRIDGE COMMITTEE AGENDA ITEM: 37
TECHNICAL COMMITTEE: T-14 / T-5

Commentary EXCERPTS 6.7.4 Diaphragms and Cross-Frames

- Refined analysis model for simple bridge geometries is not typically warranted.
- NCHRP (2021) bridges with a skew index > 0.3 produced significant live load forces in cross-frames.
- $ADTT_{SL} > 1,500$, engineering judgment should be used.

In Summary -LRFD COMMENTARY states
Do not need to do an RMA if:
 $Is \leq 0.3$, and $ADTT_{SL} < 1500$ otherwise ...use Engineering Judgment
SDG 5.13 provides specific requirements for using LGA or RFM

Five Cases for SSI-G Units Overview

Table 5.13.1-1 Design Criteria for Straight Steel I-Girder Units

Case	SDG Section	Skew Angle (θ)	Skew Index (I_s)	Cross-Frame Configuration	Required Method(s) of Analysis ³	Cross-Frame Connection Type	Calculate Cross-Frame Rating Factor
1 ¹	5.13.2 & 5.13.3	$\theta \leq 20^\circ$	$I_s \leq 0.45$	contiguous ² and parallel to skew angle	LGA [LRFD 4.6.2.2]	Bearing	No
2 ¹	5.13.2 & 5.13.4	$20^\circ < \theta \leq 50^\circ$	$I_s \leq 0.3$	contiguous ² and normal to girders	LGA [LRFD 4.6.2.2]	Bearing	No
3	5.13.5	$\theta \leq 50^\circ$	$I_s \leq 0.45$	Any ⁵	LGA and RMA [LRFD 4.6.2.2 & 4.6.3]	Bearing	No
4	5.13.6	$\theta \leq 50^\circ$	$I_s \leq 0.6$	Any ⁵	RMA [LRFD 4.6.3]	Slip-critical	No ⁶
5	5.13.7	$\theta \leq 60^\circ$ ⁴	Any	Any ⁵	RMA 3D-FEA [LRFD 4.6.3]	Slip-critical	Yes

1. Staggered (similar to the term "discontinuous" as defined in LRFD 6.2) cross-frame arrangements are not permitted.

2. As defined in LRFD 6.2. This configuration may consist of removed nuisance cross-frames from a contiguous line in the vicinity of a support as discussed in LRFD C6.7.4.2. There must be an end cross-frame line located along each skewed support.

3. LGA refers to a line girder analysis defined as analyzing an individual straight girder from the rest of the superstructure system using classical force and displacement methods or finite element model in which the live load forces are determined using the LLDF defined in LRFD 4.6.2.2. RMA refers to a refined method of analysis defined in LRFD 4.6.3.

4. See SDG 1.10 for skew angle limitation.

5. See SDG 5.7.B.

6. Cross-frame(s) (or any structural element) can be load rated at the discretion of the EOR.

Cases 1 & 2: General Criteria

Table 5.13.1-1 Design Criteria for Straight Steel I-Girder Units

Case	SDG Section	Skew Angle (θ)	Skew Index (I_s)	Cross-Frame Configuration	Required Method(s) of Analysis ³	Cross-Frame Connection Type	Calculate Cross-Frame Rating Factor
1 ¹	5.13.2 & 5.13.3	$\theta \leq 20^\circ$	$I_s \leq 0.45$	contiguous ² and parallel to skew angle	LGA [LRFD 4.6.2.2]	Bearing	No
2 ¹	5.13.2 & 5.13.4	$20^\circ < \theta \leq 50^\circ$	$I_s \leq 0.3$	contiguous ² and normal to girders	LGA [LRFD 4.6.2.2]	Bearing	No

Case 1

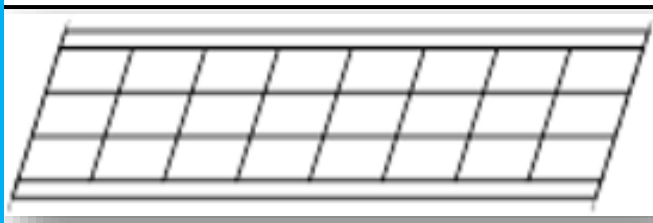

$L_s = 174$ ft; $\theta = 20^\circ$; $I_s = 0.07$
Cross-frames are parallel to skew angle

Rigid Differential Deflection Parameter

Case 2

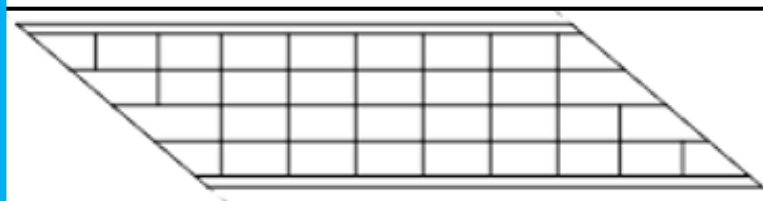

$L_s = 190$ ft; $\theta = 50^\circ$; $I_s = 0.30$
Cross-frames are normal to girders

Table 5.13.2-1 Supplemental Conditions to LRFD 4.6.2.2

Supplemental Conditions ¹	LRFD 4.6.2.2 Conditions
1. Width of deck can vary up to 5 degrees ²	Width of deck is constant
2. Girder spacing can be non-parallel up to 5 degrees ^{2,3}	Girders are parallel
3. The beam spacing must meet the range of applicability	For beam spacing exceeding the range of applicability as specified in tables in Articles 4.6.2.2.2 and 4.6.2.2.3, the live load on each beam is based on the lever rule.
4. $10,000 \leq K_g \leq 10,000,000$	$10,000 \leq K_g \leq 7,000,000$
5. Difference between skew angles of two adjacent supports does not exceed 10 degrees	Not explicitly addressed
6. $d_e / S \leq 0.35$	Not explicitly addressed
7. $0.95 \leq S/D_w \leq 2.00$	Not addressed
8. $RDDP < 175$ (see SDG 5.13.2.K)	Not addressed
1. Consider software limitations and methodologies when using Table 5.13.2-1 Supplemental Conditions to comply with these design criteria.	
2. The angle is measured between the centerline of bridge (or a line parallel to) and the edge of deck or girder line. If each side of the bridge width varies, the two angles are to be summed and then compared to the limit.	
3. Calculate LLDF using the girder spacing at the 2/3 point along the span toward the wider end.	

If the steel unit does not meet all these criteria
➤ go to Case 3

Cases 1 & 2: LGA

Rules (clarifications) for Performing an LGA

1. Distribute all non-composite dead loads equally to all girders.
2. Rules for calculating the **single weighted average** value for K_g .
3. Skew Correction Factor: apply to the lever rule and the rigid cross-section method.
4. Do not use the reduction factor for moment LLDF.
5. Optional live load deflection criteria, calculate using the moment LLDF.
6. All girders in the unit must be the same.

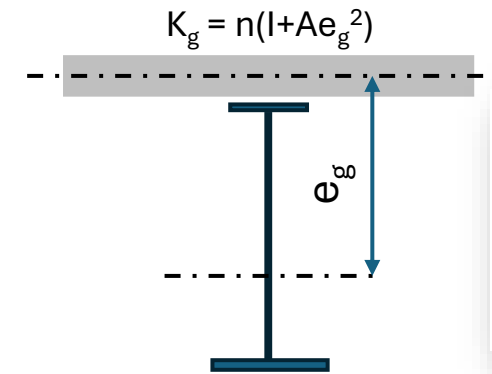
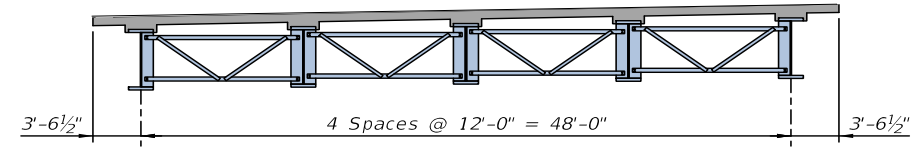

One Design Lane Loaded:

$$0.06 + \left(\frac{S}{14}\right)^{0.4} \left(\frac{S}{L}\right)^{0.3} \left(\frac{K_g}{12.0 L t_s^3}\right)^{0.1}$$

Two or More Design Lanes Loaded:

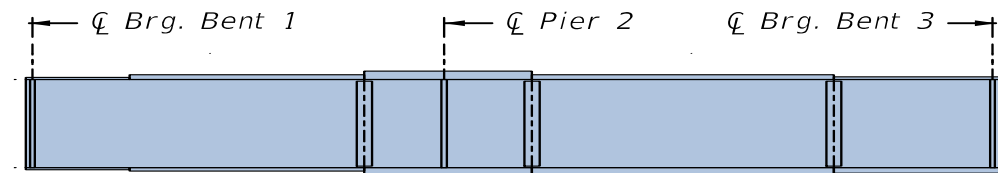
$$0.075 + \left(\frac{S}{9.5}\right)^{0.6} \left(\frac{S}{L}\right)^{0.2} \left(\frac{K_g}{12.0 L t_s^3}\right)^{0.1}$$

Cases 1 & 2: Flange Lateral Bending

Table 5.13.4-2 Girder Flange Lateral Bending Stresses Due to Skew Effects

Girder	Location ¹	Unfactored f_L^2 (ksi)	Fatigue Range f_L^3 (ksi)	Constructability f_L^5 (ksi)
Exterior	Near Support at the obtuse corner for <u>Simple Spans</u>	7.5	3.5	1
	Near End Supports at the obtuse corner for <u>Continuous Units</u>	$7.5 \leq 2.5 + (RDDP/135) * 10 \leq 12$	5.5	3
	Near Interior Supports of <u>Continuous Units</u>	4.5	N/A ⁴	3
	Within Span	0	0	0
Interior	Near Supports for <u>Simple Spans</u>	7.5	2.5	1
	Near End Supports for <u>Continuous Units</u>	10	4.5	2
	Near Interior Supports of <u>Continuous Units</u>	7.5	N/A ⁴	2
	Within Span	0	0	0

Girder Design Checks (Case 2) for:

Case 1 FLB = 0

- Strength I (1.6x) and Service II (1.2x)
- Fatigue I (or II) (need to factor and apply 0.65x)
- Constructability

Near is defined as the first two cross-frame lines adjacent to the support. Transition the flange lateral bending stress from the value in the table at the first cross-frame location to a value of zero at the second cross-frame location.

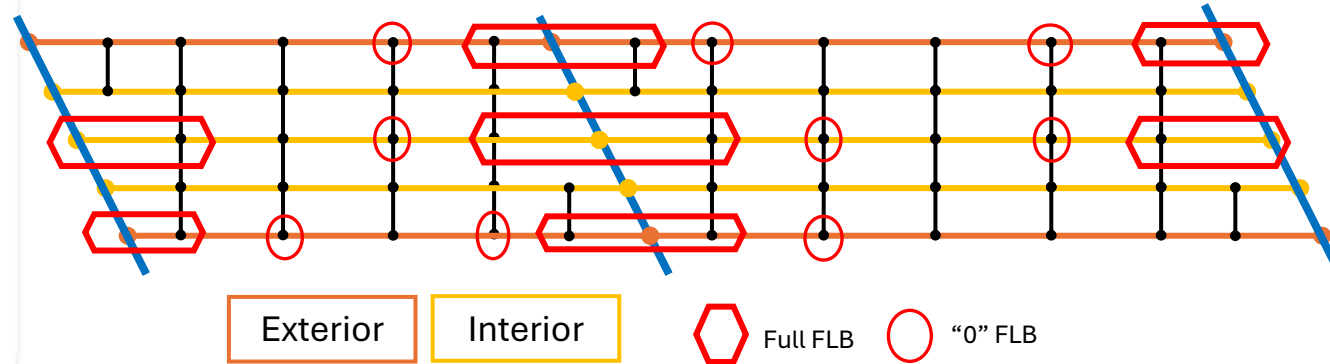

Cases 1 & 2: Cross-frame Forces

For intermediate cross-frames, use only load combinations for:

- Strength I
- Fatigue I or II (*NEW* SDG 2.12.3 for $ADTT_{SL}$)
- Constructability

Use “K” frames for intermediate cross-frames as shown in SDM Figure 16.7-1.

Evenly space cross-frames, with a spacing not to exceed 30-feet.



Table 5.13.3-1 Case 1

Table 5.13.4-3 Cross-Frame Component Forces

Load Case	Top Chord	Diagonals	Bottom Chord
Intermediate Cross-Frames Simple Spans			
Strength I ¹ (kips)	40	70	$1.3 \cdot RDDP + 85 \cdot (S/D_w) - 115 \geq 100$
Fatigue Range ² (kips)	10	12	$0.10 \cdot RDDP + 3 \cdot (S/D_w) + 5 \geq 15$
Constructability ³ (kips)	15	10	20
Intermediate Cross-Frames Continuous Spans			
Strength I ¹ (kips)	50	$0.35 \cdot RDDP + 20 \cdot (S/D_w) + 20 \geq 70$	$1.3 \cdot RDDP + 85 \cdot (S/D_w) - 90 \geq 100$
Fatigue Range ² (kips)	10	$0.05 \cdot RDDP + 11$	$0.20 \cdot RDDP + 8 \cdot (S/D_w) - 2 \geq 15$
Constructability ³ (kips)	40	20	40
End Cross-Frames			
Strength I ^{1,4} (kips)	100	100	75
Fatigue Range ² (kips)	10	10	10
Constructability ^{3,4} (kips)	10	10	10

1. The forces shown for Strength I are already factored.
2. Apply load factors for Fatigue I or II loading combinations as applicable. In addition, apply a factor of 0.65.
3. The values are for the unfactored force induced into the cross-frames due to the weight of the concrete deck and SIP forms. Apply other forces effects as applicable.
4. For end cross-frames directly supporting a free edge of the concrete deck, these forces do not include effects of the concrete edge beam weight and a local wheel load.

Cases 1 & 2: RDDP

Rigid Differential Deflection Parameter

Load Case	Top Chord (kips)	Diagonals (kips)	Bottom Chord (kips)
SDL, NLF	20	10	20
CDL	45	20	40
DC2	15	15	30
DW	3	3	5
HL-93 Live Load, Simple Span Bridges	20	40	70
HL-93 Live Load, Continuous-Span Bridges	60	80	140
STR I, Simple Span Bridges	40	70	120
STR I, Continuous-Span Bridges	100	180	$200 + 340 I_s \leq 300$ for $I_s \geq 0.15$
Fatigue Range, AASHTO 9 th Edition	30	40	70
Fatigue Range, AASHTO 10 th Edition	20	25	50

BEB13 Table 47. Recommended force estimates for intermediate cross frames in Category 2C bridges

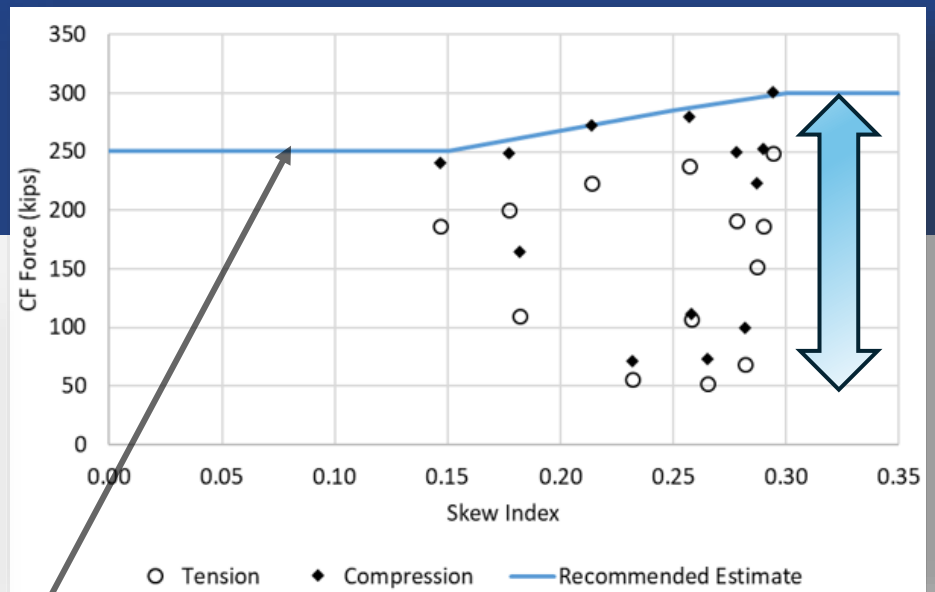

BEB13 Figure 121. Maximum STR I forces in bottom chords of intermediate cross frames in continuous-span Category 2C bridges

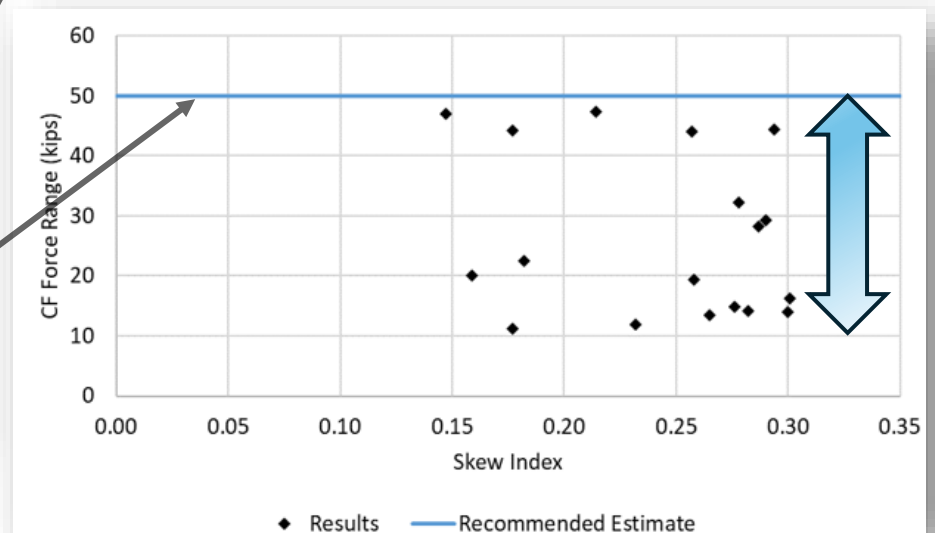

BEB13 Figure 133. Maximum fatigue force ranges, AASHTO 10th edition, in bottom chords of intermediate cross frames in Category 2C bridges

Cases 1 & 2: RDDP

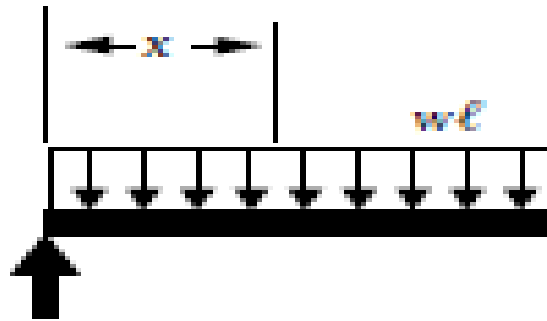
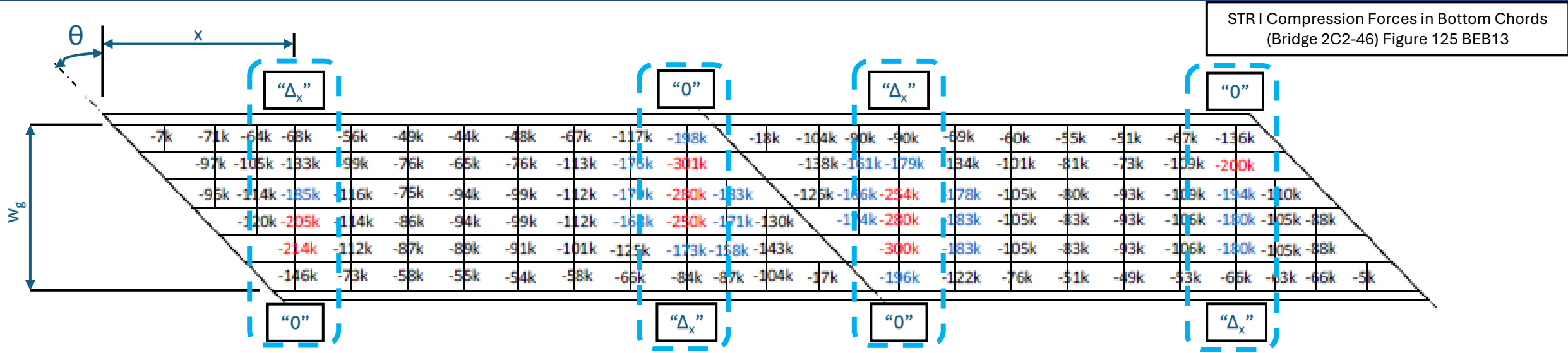

Simple Beam Formula

$$\Delta_x = \frac{wx}{24EI} (\ell^3 - 2\ell x^2 + x^3)$$

$$\Delta_x = w * [x(L^3 - 2Lx^2 + x^3) / 24EI]$$

$$x = w_g * \tan \theta$$

L = maximum span length in the unit

$K_g = 24EI$ (LRFD longitudinal stiffness parameter)

Define: **Differential Deflection Parameter**

$$DDP = x(L^3 - 2Lx^2 + x^3) / K_g$$

Cases 1 & 2: RDDP

STR I Bottom Chord Forces (k)

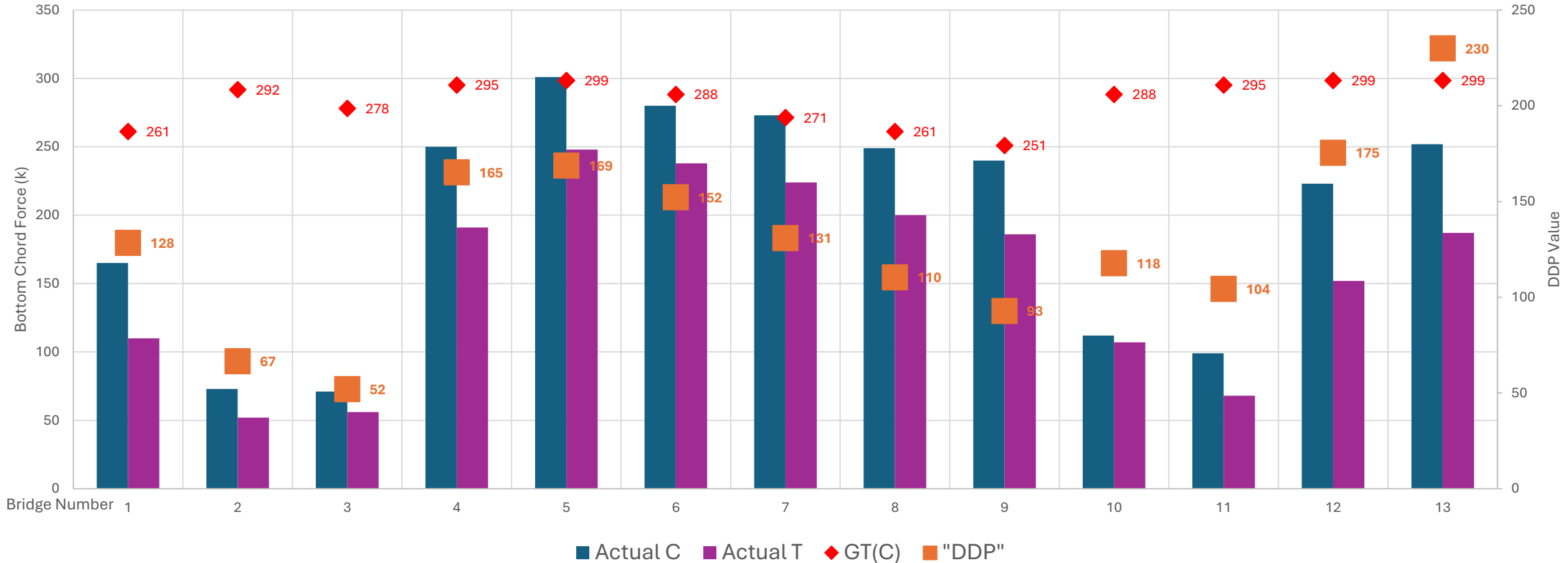

Cases 1 & 2: RDDDP

By trial and error, added two other variables

$$(L_{\text{eff}}/100) * \cos \theta * \text{DDP} = \text{RDDDP}$$

Rigid Differential Deflection Parameter

L_{eff} = Effective Span Length

For Simple spans, L_{eff} = span length

For continuous spans

(non-composite dead load contraflexure - NCDLC):

- distance between a simple support and a NCDLC, or
- between points of NCDLC.

For Two-span continuous, use maximum.

For three or more continuous spans, use the largest of:

- 1) effective span length of the maximum interior span,
- 2) 50% of the maximum interior span length, or
- 3) 65% of the effective length of the maximum end span.

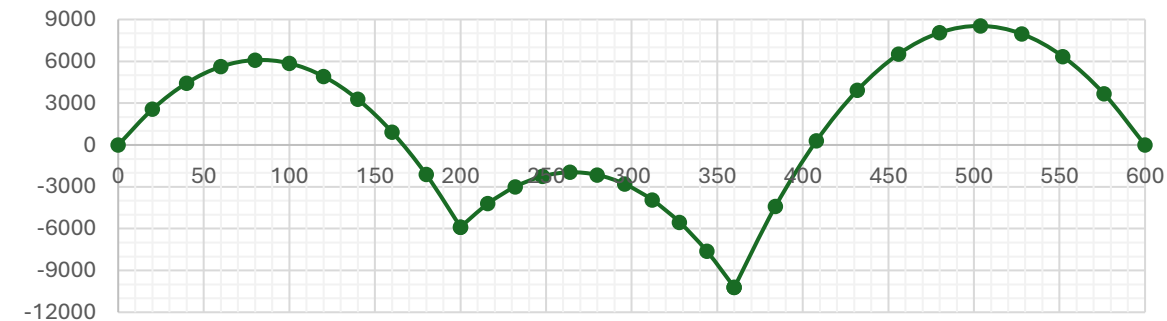
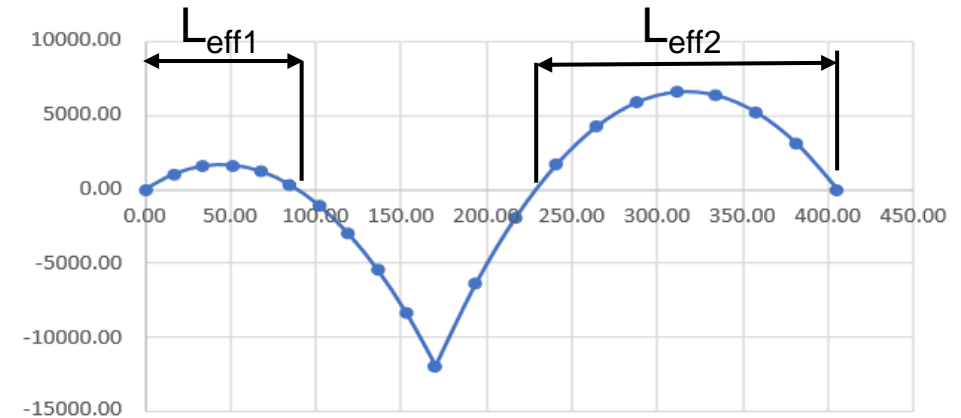

Cases 1 & 2: Fatigue Moment Range LLDF

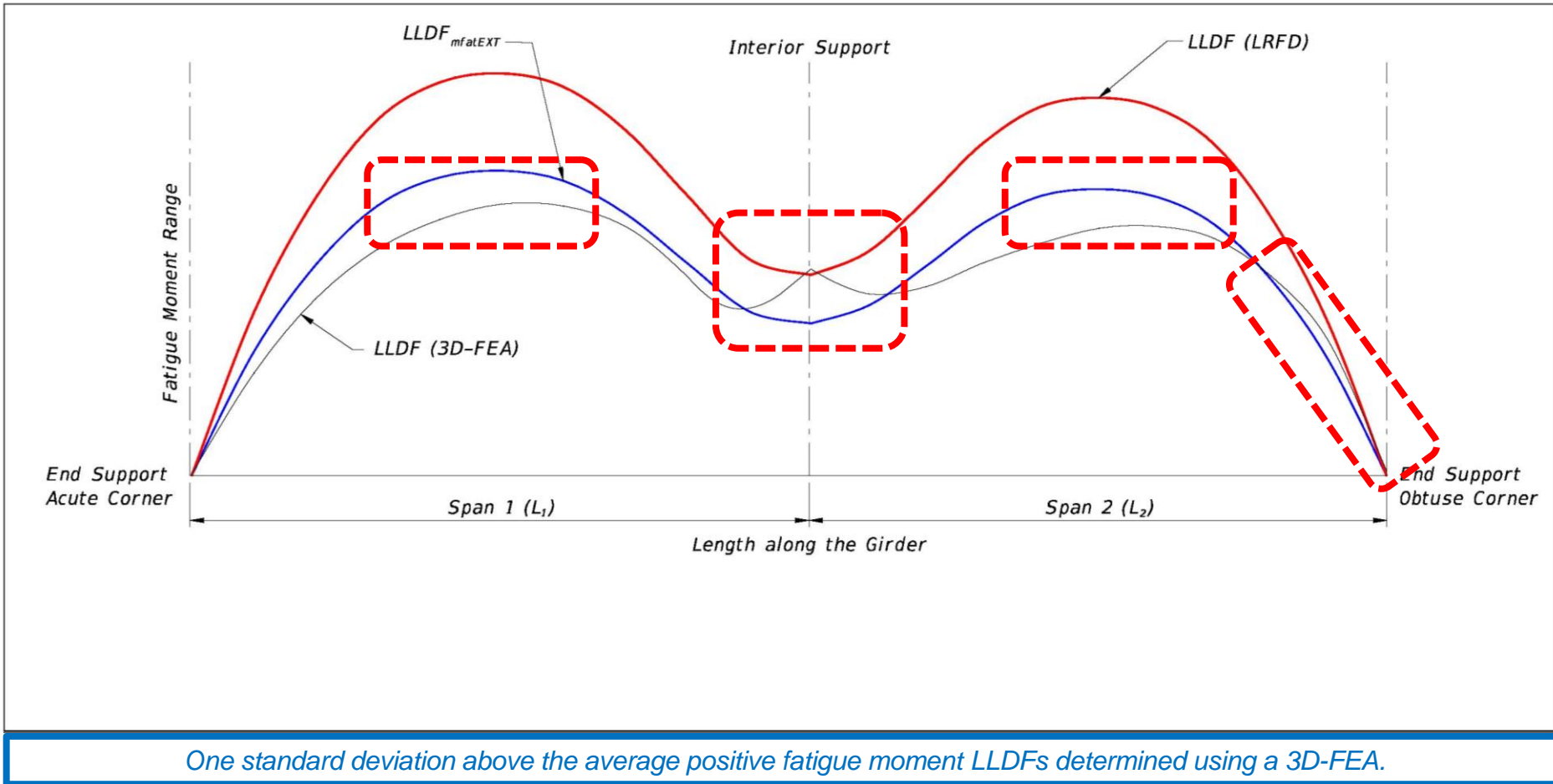

Cases 1 & 2: Fatigue Moment Range LLDF

$$LLDF_{mfatEXT} = 1.2 \cdot e_M \cdot g_{interior}$$

One Design Lane Loaded:

$$0.06 + \left(\frac{S}{14}\right)^{0.4} \left(\frac{S}{L}\right)^{0.3} \left(\frac{K_g}{12.0Lt_s^3}\right)^{0.1}$$

- $g_{interior}$ is the “One Design Lane Loaded” equation from LRFD Table 4.6.2.2.2b-1.
 - Do not divide by 1.2 per LRFD 3.6.1.1.2.
- e_M is the same as “e” per LRFD Table 4.6.2.2.2d-1 with the value not to exceed 1.0.

Applies to:

- Case 1 continuous spans and Case 2.
- 4 or more girders.
- All spans in Unit have lengths $\geq 150'$.
- Girder spacing $\geq 9'$.
- $d_e/S \leq 0.26$

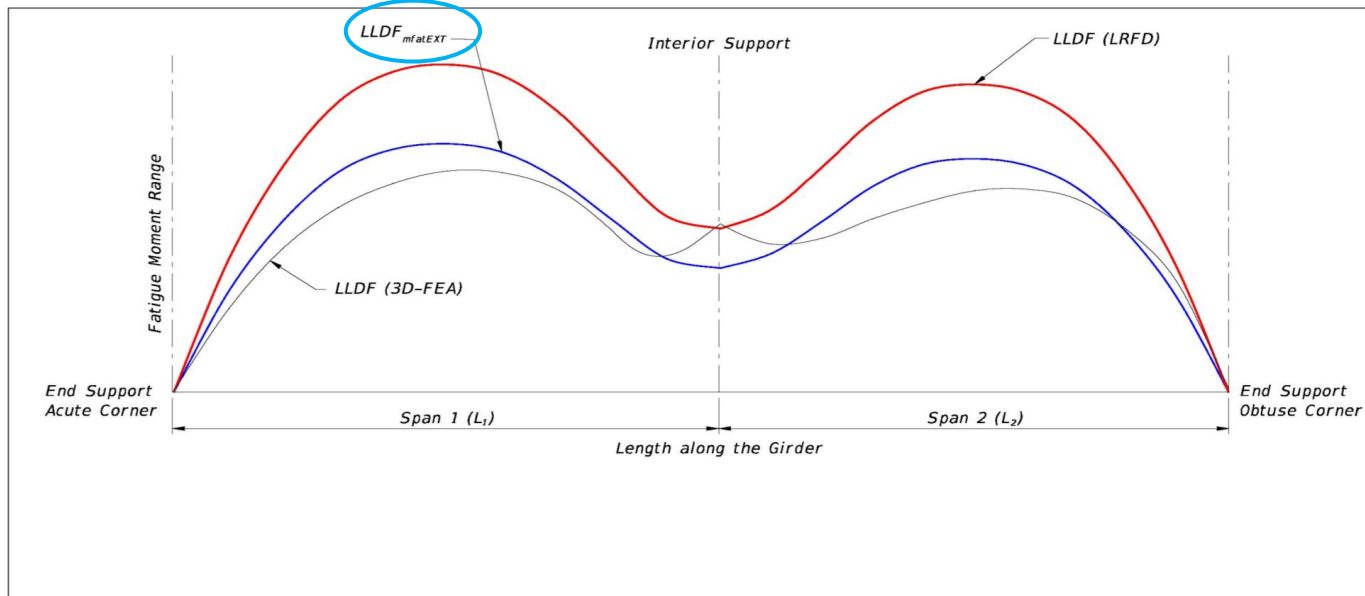

Cases 1 & 2: Fatigue Moment Range Modifications

Zone 1: In the vicinity of the Support

- Use the LRFD LLDF at the support
- Use $LLDF_{mfatExt}$ at the adjacent 10th point on each side of the support
- Transition linear interpolate between points

Figure 5.13.2-1 Fatigue Moment Range Modifications

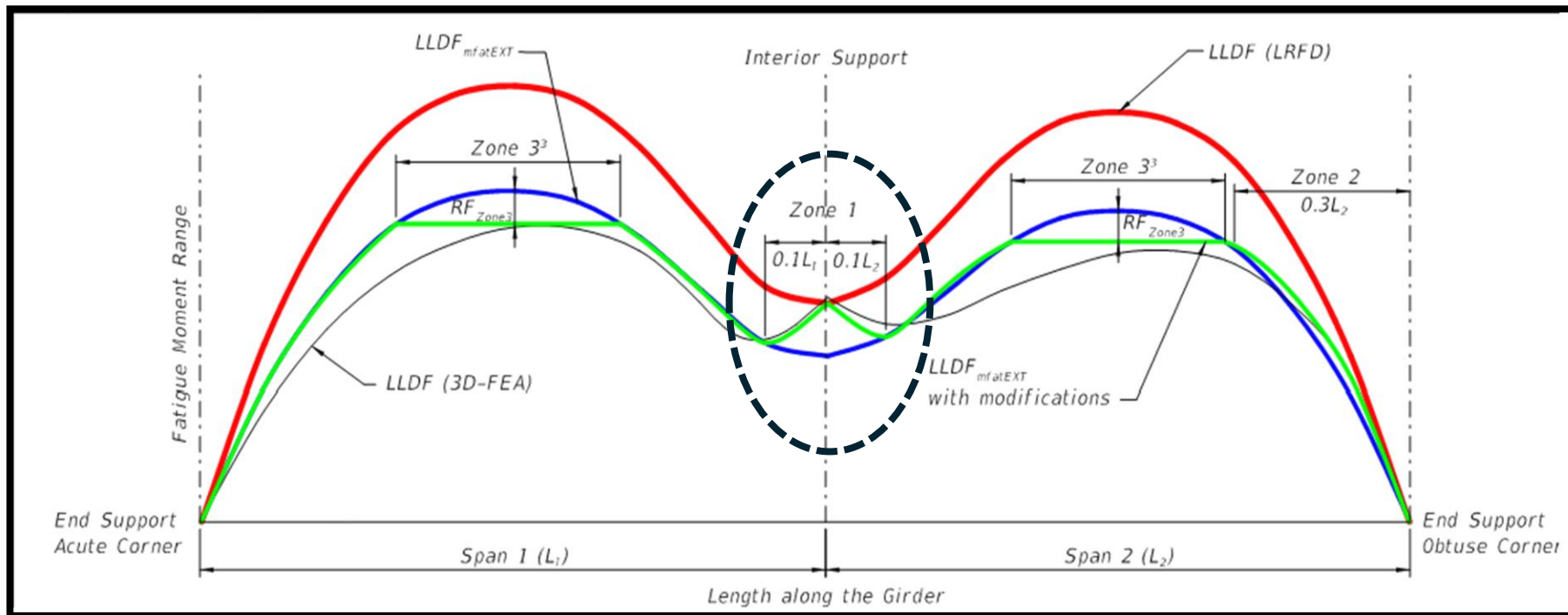

Cases 1 & 2: Fatigue Moment Range Modifications

Zone 2: In the vicinity of the End Support at the obtuse corner

- Applies to the last 30% of the span length
- Calculate SCR at the tenth points

Table 5.13.2-2 Fatigue Moment Range Skew Correction Factor, SCF_{mfat}

Length of Applicability	Simple Spans ^{1,2}	Continuous Spans ^{1,2}
Case 1	Not Applicable	1.1
Case 2	$1.33(1 + 0.06 * RDDP^{0.3}) - 0.33$ ≤ 1.35	$1.5(1 + 0.03 * RDDP^{0.4}) - 0.5$ ≤ 1.35

1. Only applicable at end supports at the obtuse corner of the span(s).
2. Decrease the SCF_{mfat} value linearly to a value of 1 at the end of the length of applicability.

Figure 5.13.2-1 Fatigue Moment Range Modifications

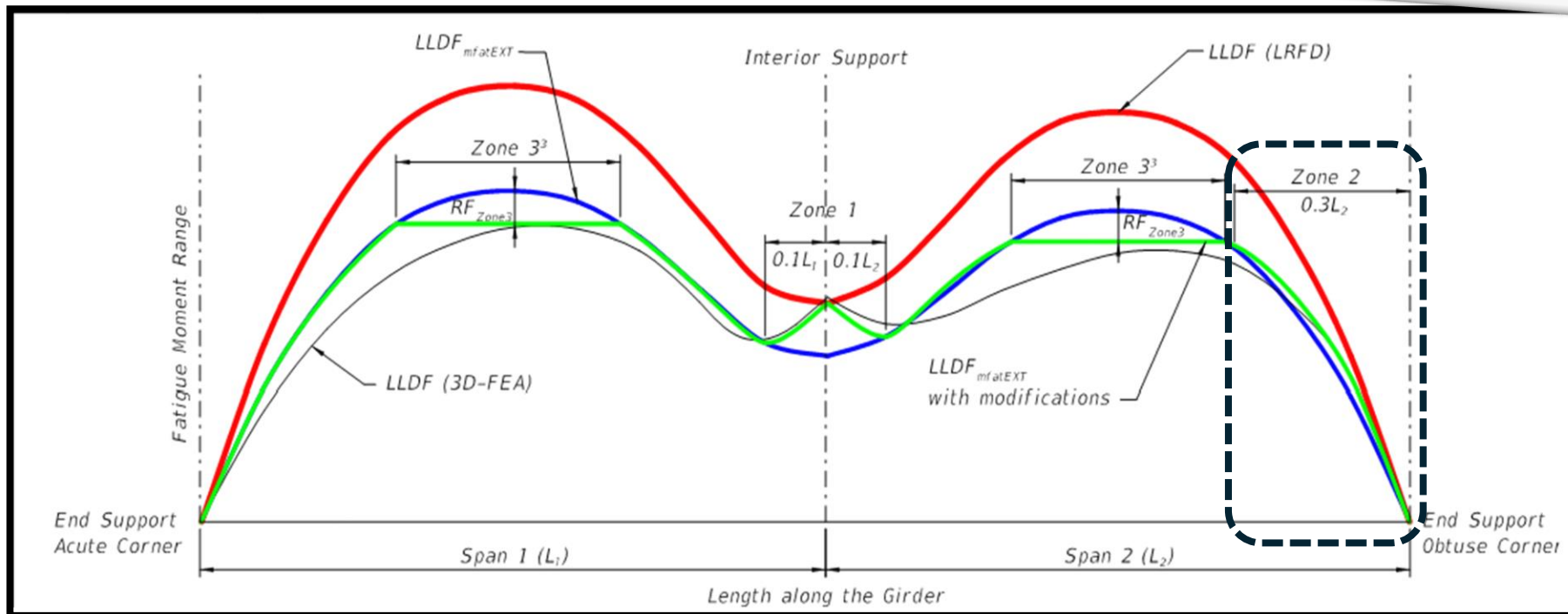

Cases 1 & 2: Fatigue Moment Range Modifications

Zone 3: In the vicinity of positive moment areas

- Calculate the reduction factor, RF_{Zone3}
- Apply it to the maximum stress range
- Extend this Reduced maximum value as a horizontal line

$$RF_{Zone3} = 0.09 * RDDP$$

Figure 5.13.2-1 Fatigue Moment Range Modifications

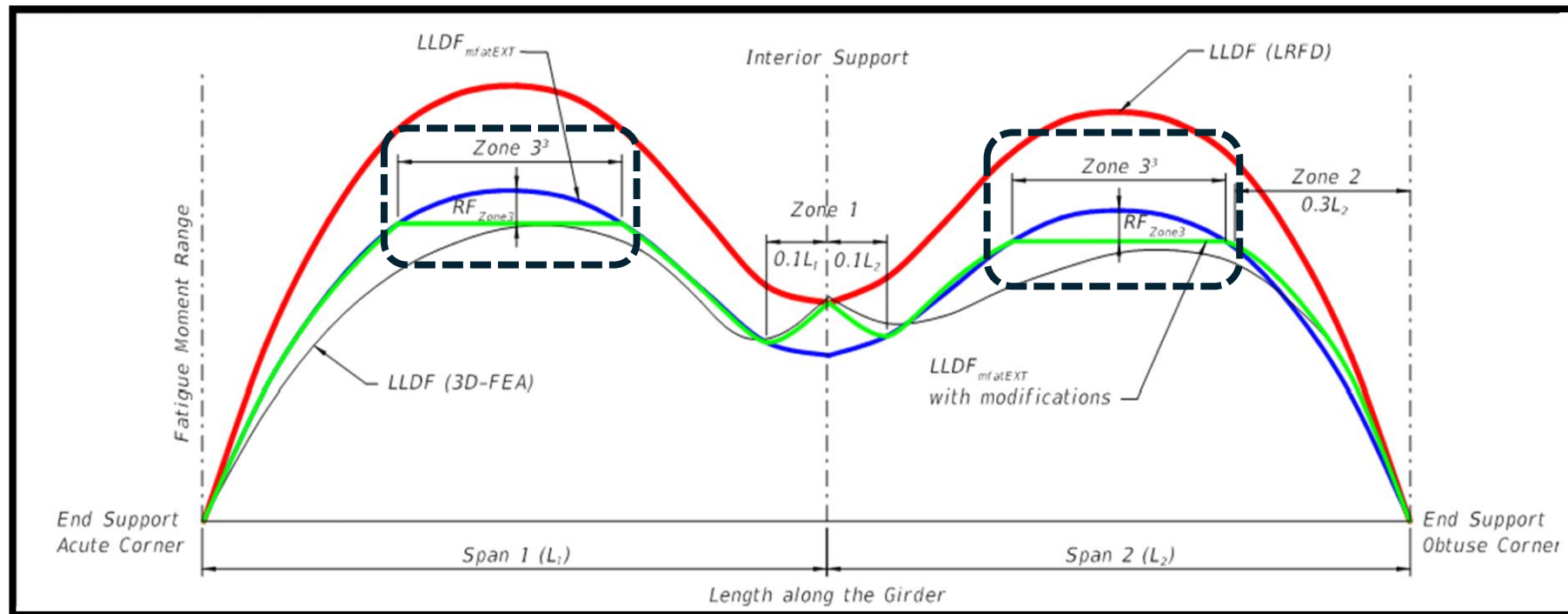

Cases 1 & 2: Summary

LGA - Required

Girder Behavior Modifications - Case 2

Flange Lateral Bending stresses

Cross-frame loads

NEW Fatigue Moment LLDF for the Exterior Girder

Case 3: LGA & RMA

Table 5.13.1-1 Design Criteria for Straight Steel I-Girder Units

Case	SDG Section	Skew Angle (θ)	Skew Index (I_s)	Cross-Frame Configuration	Required Method(s) of Analysis ³	Cross-Frame Connection Type	Calculate Cross-Frame Rating Factor
3	5.13.5	$\theta \leq 50^\circ$	$I_s \leq 0.45$	Any ⁵	LGA and RMA [LRFD 4.6.2.2 & 4.6.3]	Bearing	No

Supplemental Conditions 5, 6, 7 and 8 are not applicable.

Use LGA - ensures girder capacity is sufficient without relying on the cross-frames to transfer gravity loads.

Cross-frames are secondary members with bearing connections.

Use RMA for other force effects.

Criteria

Table 5.13.2-1 Supplemental Conditions to LRFD 4.6.2.2

Supplemental Conditions ¹	LRFD 4.6.2.2 Conditions
1. Width of deck can vary up to 5 degrees ²	Width of deck is constant
2. Girder spacing can be non-parallel up to 5 degrees ^{2,3}	Girders are parallel
3. The beam spacing must meet the range of applicability	For beam spacing exceeding the range of applicability as specified in tables in Articles 4.6.2.2.2 and 4.6.2.2.3, the live load on each beam is based on the lever rule.
4. $10,000 \leq K_g \leq 10,000,000$	$10,000 \leq K_a \leq 7,000,000$
5. Difference between skew angles of two adjacent supports does not exceed 10 degrees	Not explicitly addressed
6. $d_e / S \leq 0.35$	Not explicitly addressed
7. $0.95 \leq S/D_w \leq 2.00$	Not addressed
8. RDDP < 175 (see SDG 5.13.2.K)	Not addressed

Cases 4 & 5: RMA (Case 5 3D-FEA)

Table 5.13.1-1 Design Criteria for Straight Steel I-Girder Units

Case	SDG Section	Skew Angle (θ)	Skew Index (I_s)	Cross-Frame Configuration	Required Method(s) of Analysis ³	Cross-Frame Connection Type	Calculate Cross-Frame Rating Factor
4	5.13.6	$\theta \leq 50^\circ$	$I_s \leq 0.6$	Any ⁵	RMA [LRFD 4.6.3]	Slip-critical	No ⁶
5	5.13.7	$\theta \leq 60^\circ$ ⁴	Any	Any ⁵	RMA 3D-FEA [LRFD 4.6.3]	Slip-critical	Yes

5.13.6 Design Criteria for Case 4

Use a Refined Method of Analysis (LRFD 4.6.3) for Case 4 as defined in Table 5.13.1-1.

5.13.7 Design Criteria for Case 5

Use a 3D-FEA Refined Method of Analysis (LRFD 4.6.3) for Case 5 as defined in Table 5.13.1-1. The 3D-FEA analysis requirements include, but are not limited, to the following:

- Model the superstructure fully in three dimensions.
- Model the girder flanges using beam, plate, shell, or solid elements.
- Model the girder webs using plate, shell, or solid elements.
- Model the intermediate and end cross-frames components using beam, truss, or plate elements.
- Model the deck using plate, shell, or solid elements.

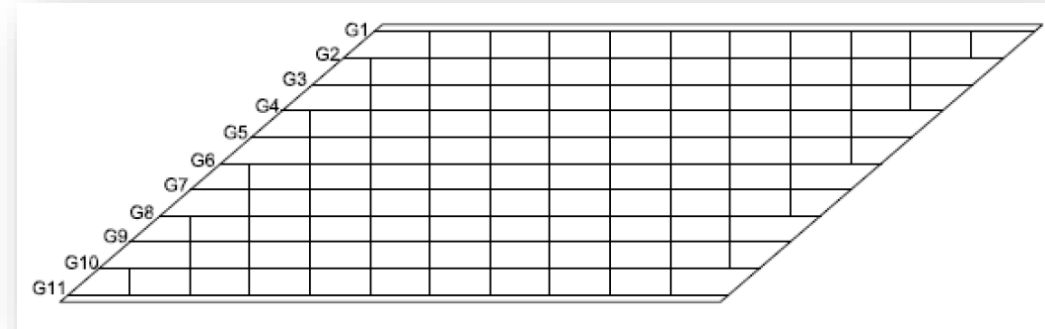

Bridge 1 ($L_s = 208$ ft; $w_g = 82.5$ ft; $\theta = 49.4^\circ, 49.4^\circ$; $I_s = 0.46$) BE535

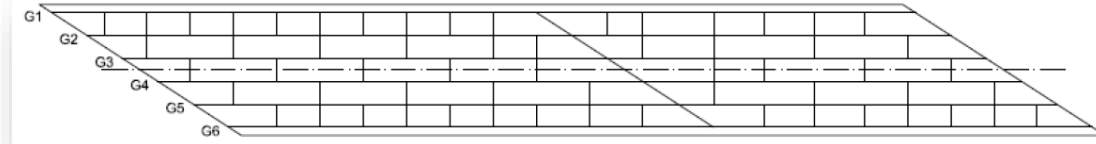

Bridge 10 ($L_s = 202$ ft, 158 ft; $w_g = 57.5$ ft; $\theta = 57.2^\circ, 57.2^\circ, 57.2^\circ$; $I_s = 0.47$) BE535

Phase Construction and Widening Rules:

5.13 STRAIGHT STEEL I-GIRDER UNITS

5.13.1 Design Cases

B. For phase construction, analyze and design each phase separately as Case 1 or Case 2 as applicable when the following criteria is met:

1. All phases meet either Case 1 or 2 criteria per Table 5.13.1-1.
2. The skew index for the entire unit at final condition (entire cross-section) is less than or equal to 0.45.
3. The construction sequence follows the requirements of **SDG 4.2.11** and **SDG 5.1.B**.

Otherwise, use the skew index for the final condition (entire cross-section) of the unit to select Case 3, 4, or 5 per Table 5.13.1-1.

7.6 WIDENING RULES

7.6.3 Steel I-Girders

I. For existing straight steel I-girder units, see Table 7.6.3-1 for criteria regarding the requirements for level of analysis, load rating, and strengthening of the existing cross-frames. Analyze the existing steel I-girder unit and analyze and design the widening separately as Case 1 or Case 2 as applicable when all the following conditions are met:

1. Both the existing and widening meet Case 1 or Case 2 criteria per Table 7.6.3-1.
2. The skew index for the entire unit (existing and proposed widening in the final condition) unit is less than 0.45.
3. The cross-frames are designed and detailed in accordance with **SDG 5.1.B**.

Otherwise, use the skew index for the entire unit (i.e., final widened configuration) to select Case 3, 4, or 5 per Table 5.13-1. See **SDG 5.13** for additional information.

Closure pour required

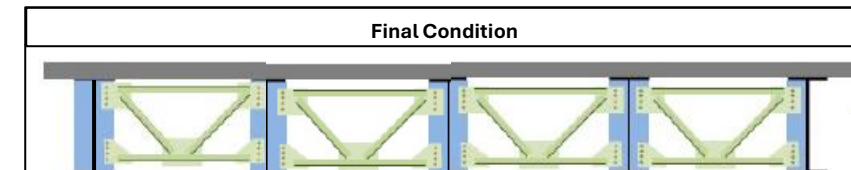
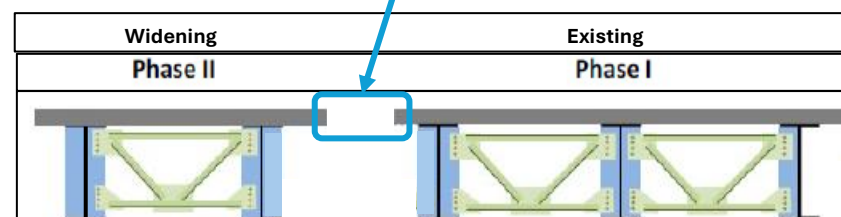
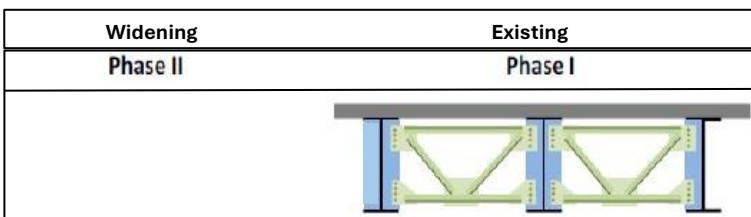

Criteria Revisions – Also for Curved I-G and Box

AASHTO Approved Ballots Upcoming
10th Ed.

- Primary and Secondary Members
- Bolted Connections
 - Bearing Type Connections (SM Only)
 - HS Bolts – Threads Excluded for CF
- Load Rating requirements for Cross-frames

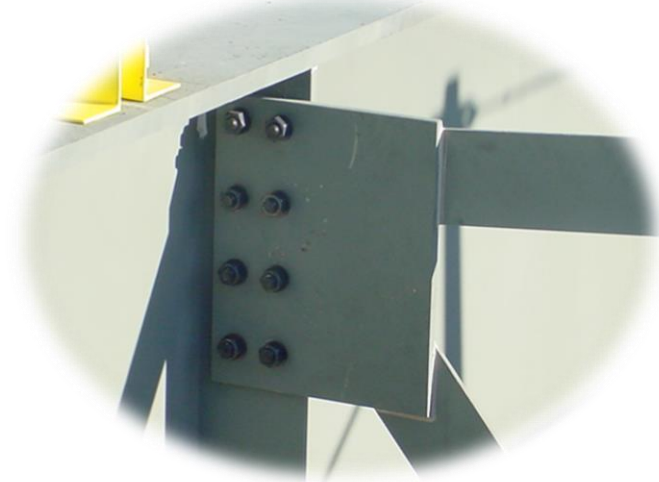

Criteria Revisions – Also for Curved I-G and Box

Primary and Secondary Members

F. Designate on the plans, all:

1. Primary (main) members. Also, identify areas of primary members that are subject to tension and stress reversal, and designate that CVN testing is required.

*Commentary: Primary members have additional fabrication and inspection criteria per Section 460 of the **Specifications** and AASHTO/AWS D1.5 Bridge Welding Code which includes but not limited to material traceability, material testing, bolt hole fabrication, welding procedures, and inspection*



5.3.2 Fracture (LRFD 6.6.2)

- A. Replace rows 10 and 11 in **LRFD** Table 6.6.2.1-1 as shown below. Members in row 11 are exempt from Charpy V-notch (CVN) testing. See **SDM** 2.14 for the definition of skew angle.

<p>Diaphragm and cross-frame members and mechanically fastened or welded cross-frame gusset plates in non-skewed straight I-girder units that are designated as Case 1, 2, or 3 (see SDG 5.13.1), bridges, skewed straight I girder bridges having a skew angle $\leq 50^\circ$ and a bridge skew index ≤ 0.45, and in horizontally curved I-girder bridges satisfying all the conditions specified in Article 4.6.1.2.4b (for neglecting the effects of curvature)</p>	Secondary
<p>Diaphragm and cross-frame members and mechanically fastened or welded cross-frame gusset plates in straight-skewed I-girder units that are designated as Case 4 or 5 (see SDG 5.13.1), bridges having a skew angle of $> 50^\circ$ or a bridge skew index of > 0.45 and in horizontally curved I-girder bridges not satisfying one or more of the conditions specified in Article 4.6.1.2.4b (for neglecting the effects of curvature)</p>	Primary

Row 10

Row 11

Criteria Revisions – Also for Curved I-G and Box

Primary and Secondary Members

Steel Box - added information from the 10th Ed.

FDOT specific: added reference to SDG 5.6.3.D

B. Add the following rows to *LRFD* Table 6.6.2.1-1 immediately after row 11:

<p>For composite box-girder bridges:</p> <ul style="list-style-type: none">• Intermediate internal cross-frame members and their mechanically fastened or welded gusset plates.• Intermediate internal diaphragms that are not provided for continuity.• Except as specified herein, intermediate external diaphragms or cross-frame members and mechanically fastened or welded intermediate external cross-frame gusset plates.• Internal support diaphragms in straight bridges without skewed supports or in horizontally-curved bridges satisfying all the conditions specified in Article 4.6.1.2.4c for neglecting the effects of curvature.	Secondary
<p>For composite box-girder bridges:</p> <ul style="list-style-type: none">• Intermediate internal diaphragms that are provided for continuity and their associated intermediate external diaphragms.• External support diaphragms or cross-frame members and mechanically fastened or welded external support cross-frame gusset plates.• Internal support diaphragms in straight bridges with skewed supports or in horizontally-curved bridges not satisfying one or more of the conditions specified in Article 4.6.1.2.4c for neglecting the effects of curvature.• Intermediate external diaphragms provided in bridges with concrete decks designed using the empirical design method to satisfy the design conditions specified in Article 9.7.2.4.• Intermediate external diaphragms provided in accordance with SDG 5.6.3.D.	Primary

Criteria Revisions – Also for Curved I-G and Box

Bearing Type Connections (Secondary Members)

7. Replace *Structures Design Guidelines* Section 5.4 with the following:

5.4 Bolts (LRFD 6.4.3.1 and 6.13.2)

- A. Design structural bolted connections as either bearing or slip-critical connections in accordance with *LRFD* 6.13.2 and as modified by the following:
1. *SDG* 5.13.1, and *SDG* 5.14.1.
 2. For composite box girder bridges, all connections must be slip-critical. An exception is for bridges containing secondary members, which may have bearing type connections for these members.
 3. Steel integral and/or straddle (regardless of their classification of superstructure or substructure) caps must use slip-critical connections.
- B. All bearing-type connections must use standard size holes.

SDM 5.3.E (Typical Steel GN)

- Re-formatted several notes regarding bolted connections
- Added plan notes regarding bearing connections
 - Bolts need to be tightened per Section 460-5
 - Faying surface to be prepared to SSPC SP-10

SDM 16 Revised Several Figures

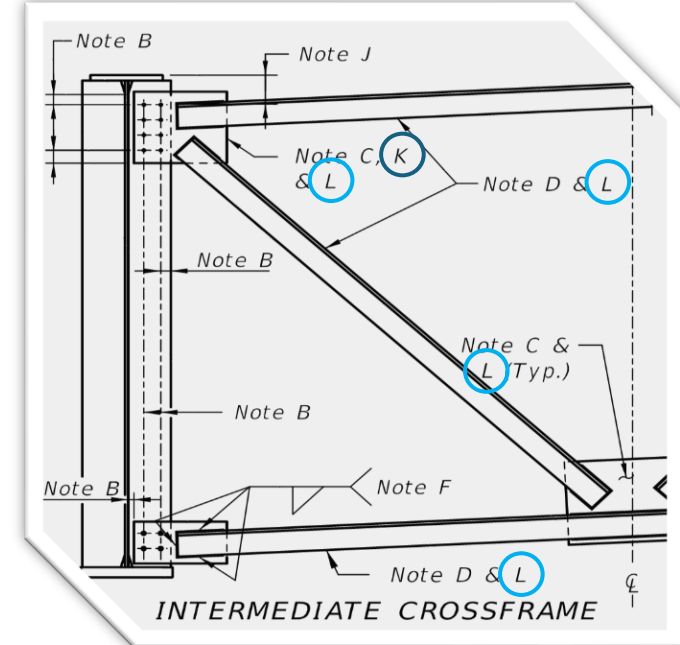

Note K:

- ❖ Specify the connection type (i.e., slip-critical or bearing).
- ❖ Specify if threads are excluded from the shear plane (see *SDG* 5.11.C).

Note L:

- ❖ Specify as primary or secondary member.

Criteria Revisions – Also for Curved I-G and Box

Load Rating of Cross-frames

Structures Design Bulletin 24-01
Analysis and Design Criteria for Steel I-Girders
Attachment 'F'
Page 2 of 2

5.14 HORIZONTALLY CURVED STEEL I-GIRDER UNITS

Design horizontally curved steel I-girder units in accordance with *LRFD* and the following requirements:

- A. For horizontally-curved I-girder units satisfying all the conditions specified in *LRFD* 4.6.1.2.4b, design the cross-frame connections as bearing connections. Do not calculate a load rating factor for the intermediate or end cross-frames.
- B. For horizontally-curved I-girder units not satisfying all the conditions specified in *LRFD* 4.6.1.2.4b, design the cross-frame connections as slip-critical connections. Do not calculate a load rating factor for the intermediate or end cross-frames except as noted in Number 3a below.
- C. Use a 3D FEA (see *SDG* 5.13.5 for requirements) refined method of analysis (*LRFD* 4.6.3) when:
 1. The *LRFD* bridge skew index is greater than 0.6 (see also *SDG* 1.10). Calculate a rating factor for the intermediate cross-frames.
 2. The central angle (any span in the unit) is greater than 0.06 radians and the *LRFD* bridge skew index is greater than 0.4 but less than or equal to 0.6. Do not calculate a load rating factor for the intermediate or end cross-frames.

Excerpt from
Table 5.13.1-1

Case	Calculate Cross-Frame Rating Factor
1 ¹	No
2 ¹	No
3	No
4	No ⁶
5	Yes



ADTT_{SL}

ADTT_{SL} is used to determine if a fatigue detail category is Fatigue I or II

What we have: AADT-opening year, and the design year AADT data which is typically 20 years from the opening date (roadway Typical Section package) (uses traffic forecasting procedures as referenced in FDM 120)

IF bridge life is 75 years, what AADT-year should the ADTT_{SL} be based on?

AADT₃₈

GR

$$GR = (AADT_{20}/AADT_0)^{1/20}$$

Where : AADT₀ = opening year
AADT₂₀ = design year (+20)

AADT₃₈

$$AADT_{38} = AADT_0 \cdot GR^{38} \cdot D$$

AADT₃₈ is assumed to be an average AADT over the 75-year life of the bridge

ADTT_{SL}

$$ADTT_{SL} = AADT_{38} \cdot T \cdot p$$

Check for Fatigue I or II

Fatigue I – 

Fatigue II – 

Number of Cycles

$$N = (365)(75)n(ADTT)_{SL}$$

If another design year and/or bridge life is used, adjust the GR and mid-life AADT accordingly.

Wrap-Up

- ✓ θ , I_s & CF arrangement defines Cases for SSI-G bridges
- ✓ 5 Cases: Required Method of Analysis, CF connection type, and CF LR
 - ✓ Cases 1 & 2 LGA with tabulated FLB stresses and CF loads
 - ✓ Case 3 LGA supplemented with RMA
 - ✓ Case 4 & 5 RMA
- ✓ Phase Construction and Widening Rules
- ✓ Criteria Revisions – Also for Curved Steel I-G and Steel Boxes
 - ✓ Primary and Secondary Members
 - ✓ Bearing Connections for Secondary Members
 - ✓ Load Rating of Cross-frames
- ✓ $ADTT_{SL}$ (Growth factor, $AADT_{38}$)

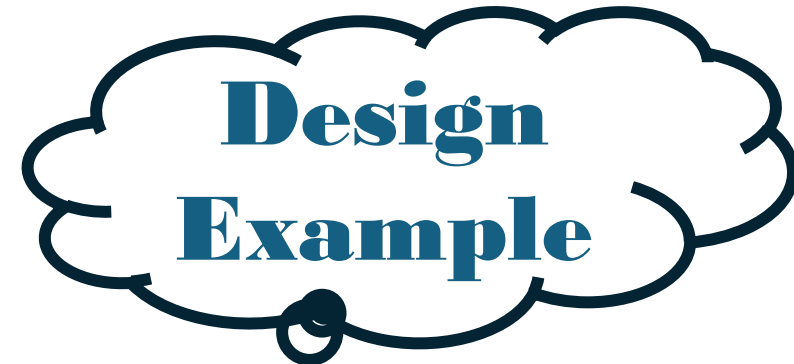

Quiz:

1. True or **False**. You can always use a 3D-FEM for the method of analysis of an SSI-G unit.
2. True or **False**. HS Bolted connection in a primary member may be designed for only bearing if you meet the criteria in SDB 24-01.
3. **True** or False. For a SSSI-G unit with a skew index > 0.6 , you must use a full 3D-FEA.
4. **True** or False. Cross-frames are not required to be load rated for SSSI-G units meeting any Case 1 to 4.

5. For calculating the ADTT(SL) use which of the following:
 - a) +20-year AADT
 - b) +38-year AADT**
 - c) +75-year AADT



6. RDDP stands for:
 - a) Remote Direct Data Placement
 - b) Rigid Differential Deflection Parameter**
 - c) Required Driven Development Process

Safety Message

**TAKE A
BREAK**
Don't drive drowsy.



FLHSMV



Contact Us



Vickie Young, P.E.
Assistant State Structures Design
Engineer
(850) 414-4301
Vickie.Young@dot.state.fl.us



Questions:

