

Origination Form
 Proposed Revisions to a Standard Plans Index

Originator:	Rick Jenkins	Index Number:	520-020
Date:	2/24/2026	Sheet Number(s):	1
E-mail:	rick.jenkins@dot.state.fl.us	Index Title:	Traffic Separators

Summary of the changes:

Sheet 1: In the "CONCRETE TRAFFIC SEPARATOR" details, added "Backfill (See Note 4)" callouts for all of the blank voids. Added Note 4 to explain the void fill requirements.

Commentary/Background:

Districts commented that the voids were undefined on the Standard Plans sheet. This revision helps to clarify what goes in the voids and provides a reference to the corresponding Standard Plan.

Other Affected Documents/Offices	Person Contacted	Affected (Yes/No)
Other Standard Plans		No
FDOT Design Manual		No
Standard Specifications		No
Basis of Estimates Manual		No
Approved Product List		No
Construction Office		No
Maintenance Office		No

Implementation

FY 2027-28

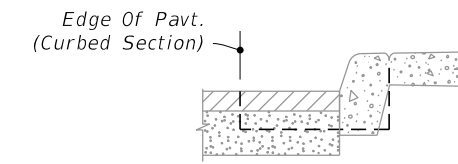
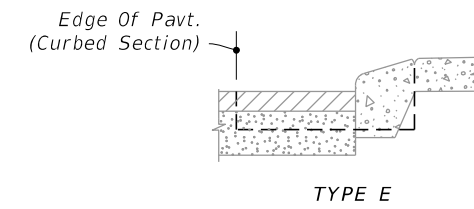
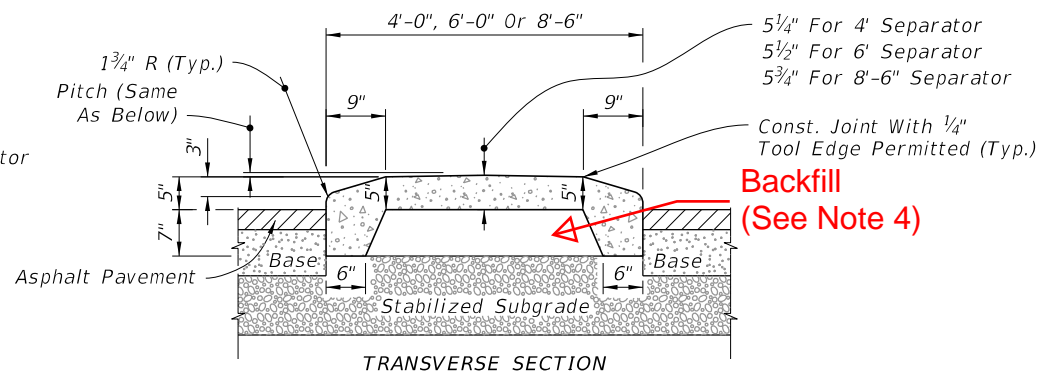
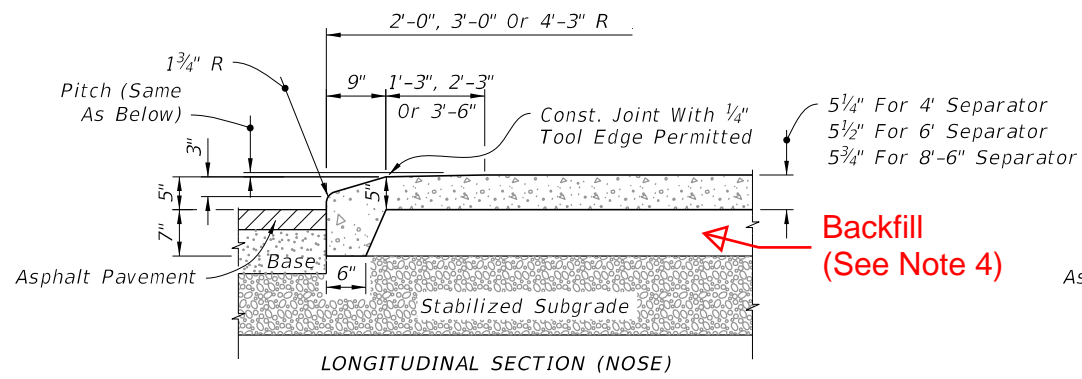

CURB AND GUTTER

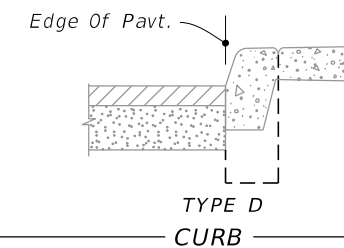
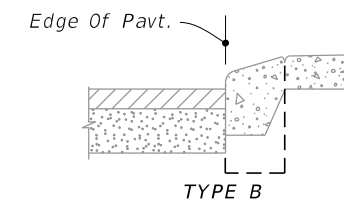
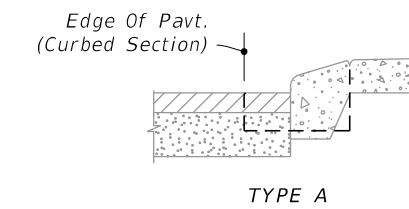

CURB

MEDIAN CURB AND TRAFFIC SEPARATOR JUNCTURE DETAILS

(Option I Separator Shown, For Curb Details see Index 520-001)

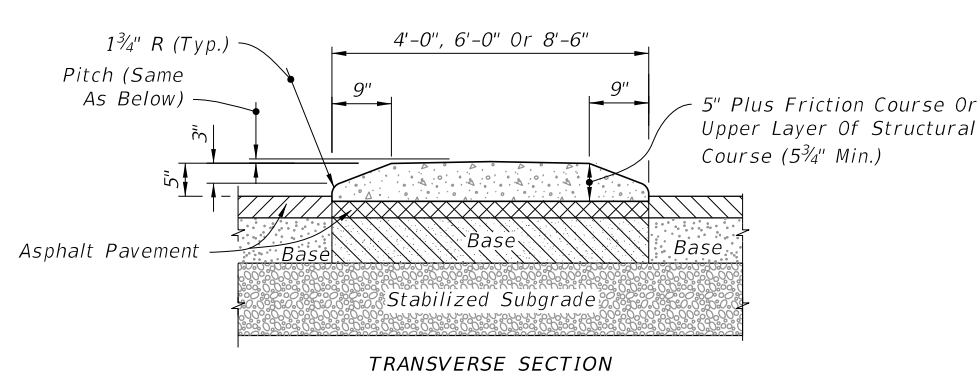
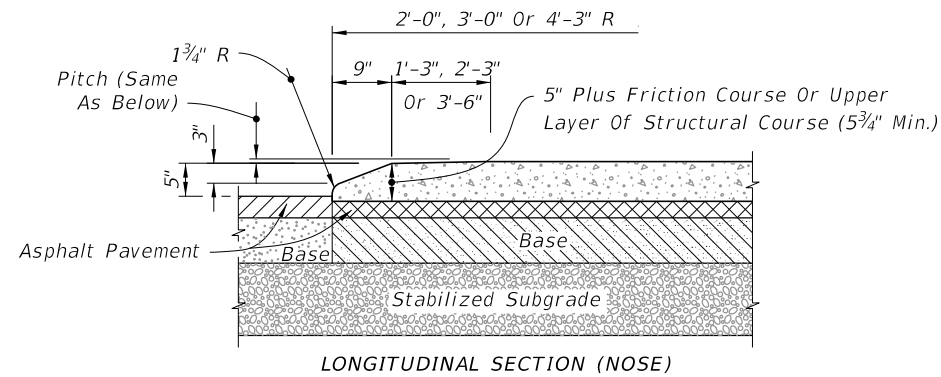

TYPE I - CONCRETE TRAFFIC SEPARATOR

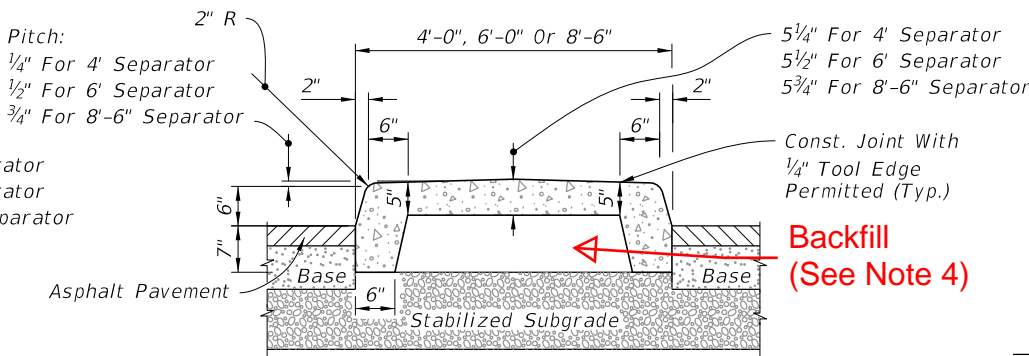
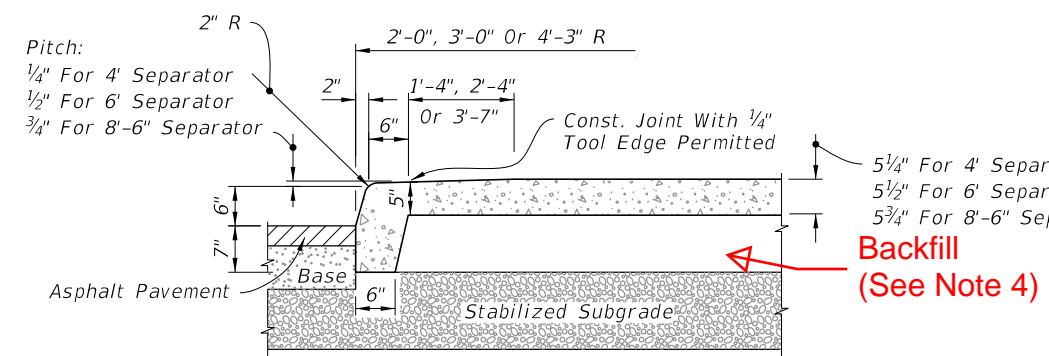

OPTION I

NOTES:

1. Separators Type I and IV are to be used with flexible pavement. Separators Types II and V are to be used with rigid pavement.
2. Either Option I or Option II may be used for Types I and IV separators except when a specific option is called for in the Plans.
3. For all separators provide 1/8" - 1/4" contraction joints at 10' centers (max.). Contraction joints adjacent to concrete pavement on tangents and flat curves to match the pavement joints, with intermediate joints not to exceed 10' center.

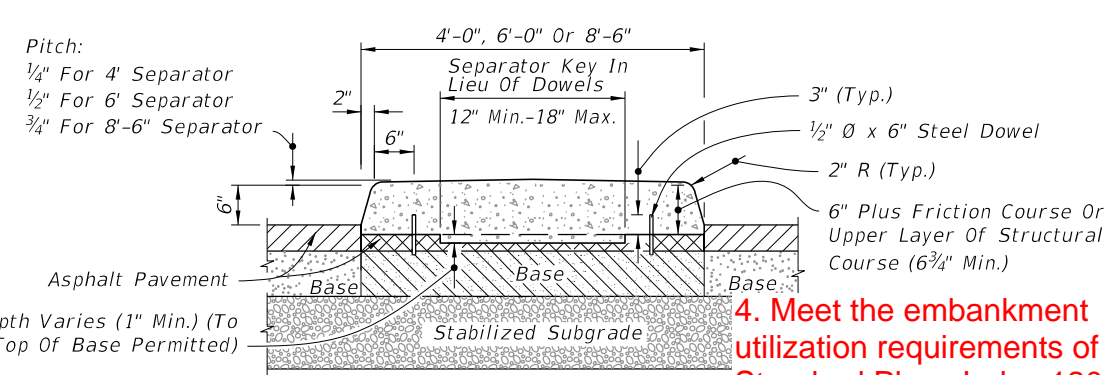
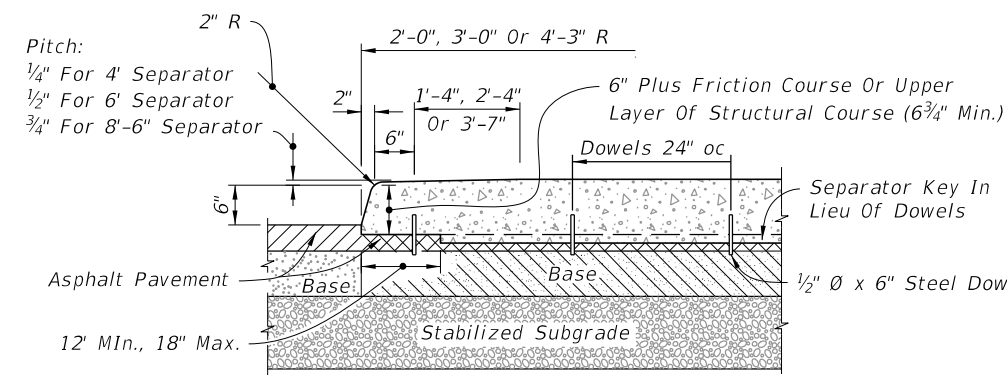

OPTION II

TYPE IV - CONCRETE TRAFFIC SEPARATOR

4. Meet the embankment utilization requirements of Standard Plans Index 120-001.

2/13/2026 8:33:40 AM

2027-28

ROADWAY INSTALLATIONS - FLEXIBLE PAVEMENT

LAST REVISION 11/01/17	DESCRIPTION: 11/01/26	FDOT	FY 2026-27 STANDARD PLANS	TRAFFIC SEPARATORS	INDEX 520-020	SHEET 1 of 5
--------------------------------------	--------------------------	------	---	--------------------	------------------	-----------------

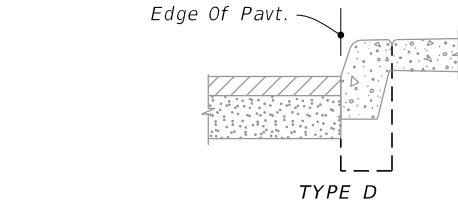
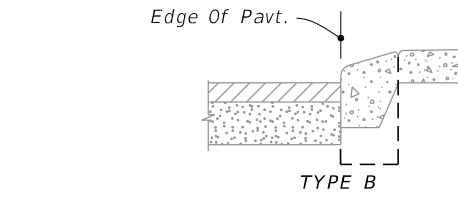
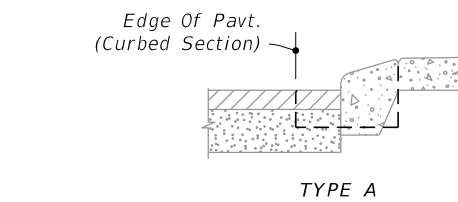
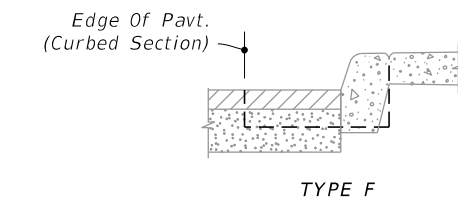
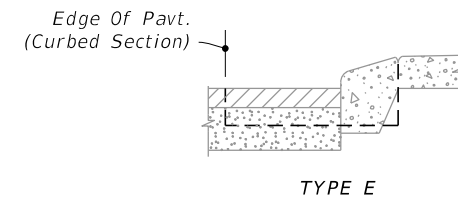
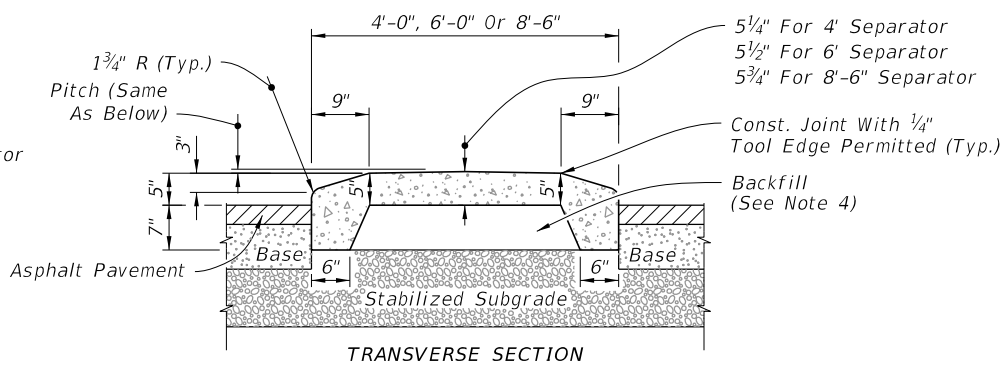
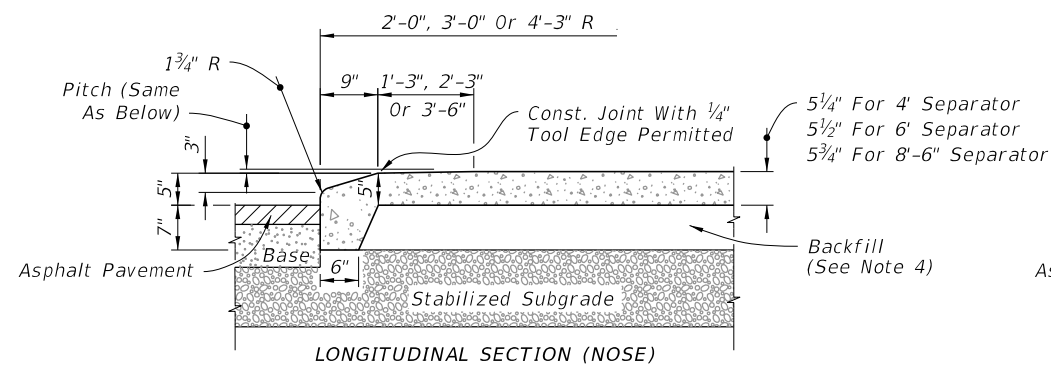

MEDIAN CURB AND TRAFFIC SEPARATOR JUNCTURE DETAILS

(Option I Separator Shown, For Curb Details see Index 520-001)

NOTES:

- Separators Type I and IV are to be used with flexible pavement. Separators Types II and V are to be used with rigid pavement.
- Either Option I or Option II may be used for Types I and IV separators except when a specific option is called for in the Plans.
- For all separators provide 1/8" - 1/4" contraction joints at 10' centers (max.). Contraction joints adjacent to concrete pavement on tangents and flat curves to match the pavement joints, with intermediate joints not to exceed 10' center.
- Meet the embankment utilization requirements of Standard Plans Index 120-001.

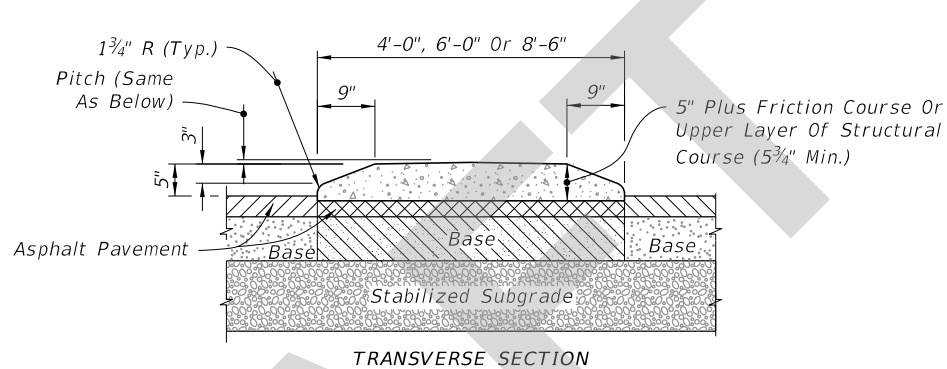
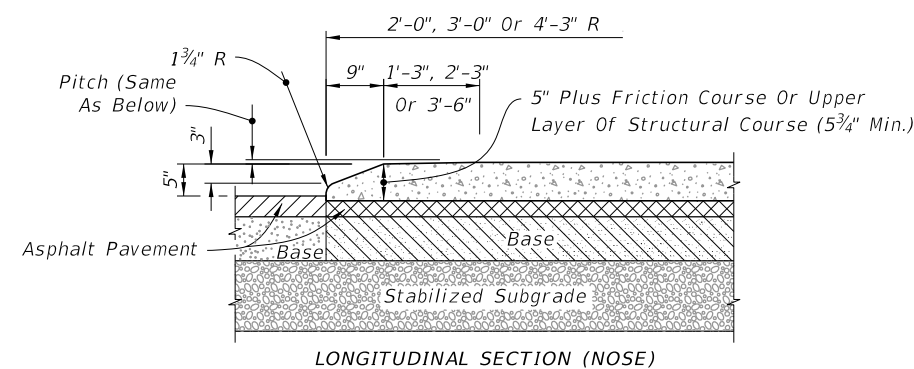

TYPE I - CONCRETE TRAFFIC SEPARATOR

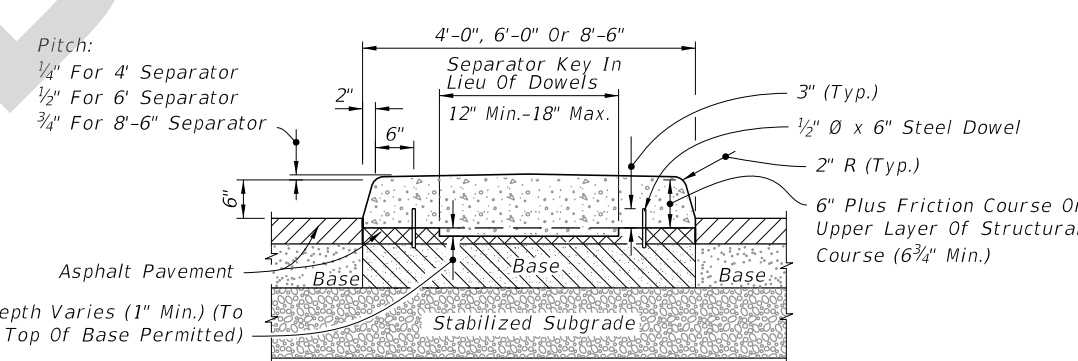
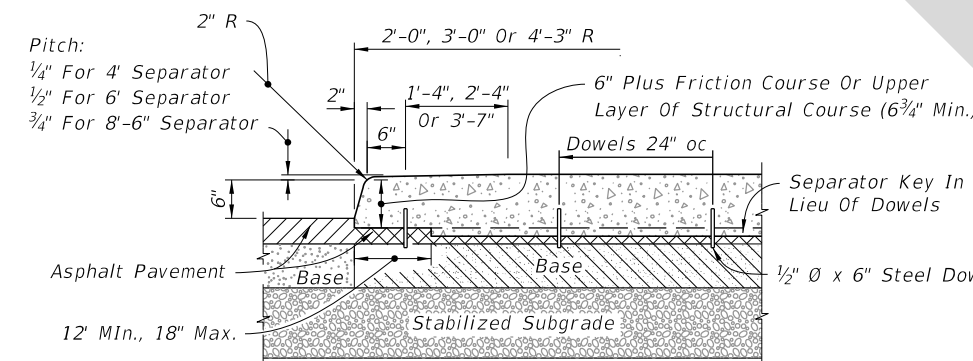
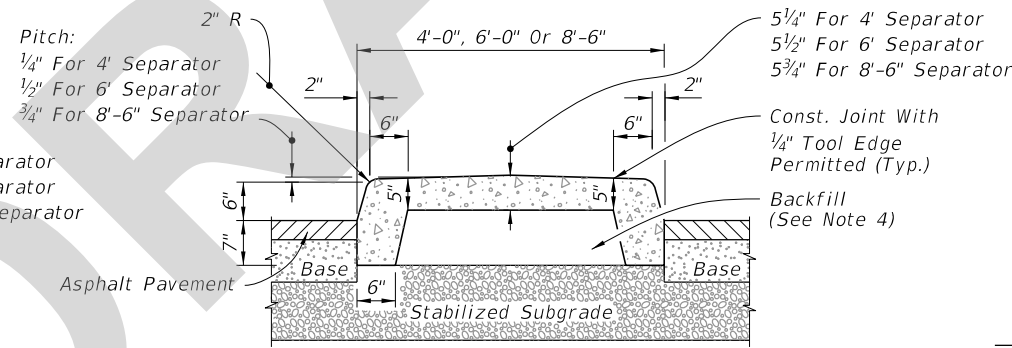
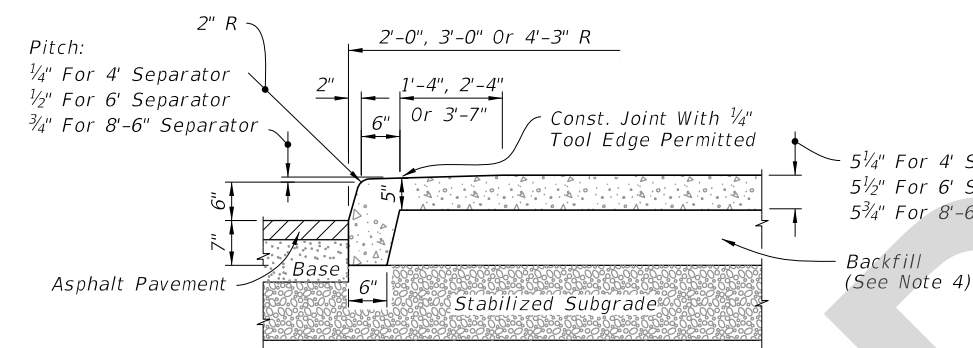

TYPE IV - CONCRETE TRAFFIC SEPARATOR

ROADWAY INSTALLATIONS - FLEXIBLE PAVEMENT

4/23/2026 8:04:44 AM

LAST REVISION 11/01/26	REVISION	DESCRIPTION:	 FY 2027-28 STANDARD PLANS	TRAFFIC SEPARATORS	INDEX 520-020	SHEET 1 of 5
---------------------------	----------	--------------	---	---------------------------	-------------------------	------------------------