

Origination Form
Proposed Revisions to a Standard Plans Index

Originator:	Gibbs, Shae	Index Number:	550-002
Date:	6/9/2025	Sheet Number(s):	All
E-mail:	shae.gibbs@dot.state.fl.us	Index Title:	Fence Type B

Summary of the changes:

ALL: General Redevelopment

Sheet 1: Deleted Materials notes and moved to division 3 Specification; Added FENCE POSITION AT LOCATIONS WITHOUT FRONTAGE ROADS details; Moved the CORNER OR END POST and PULL POST Details to Sheet 2; Added Note "Install Electrical Grounds for Fence that are installed within Electrical Transmission Right(s) of Way in accordance with Specification 550".

Sheet 2: Moved GENERAL NOTES to Sheet 1: Moved the Design Note and Table to the Standard Plans Instructions; Added the CORNER OR END POST and PULL POST Details.

Sheet 3: Moved the FENCE POSITION AT LOCATIONS WITHOUT FRONTAGE ROADS details to Sheet 1; Updated the BASE PLATE AND ANCHOR NOTES - Clarified "Expansion Bolts Not Permitted." as Note 4.

Commentary/Background:

General redevelopment done in-line with the updates to 550-001. Materials notes were moved to their respective Div III specs.

Other Affected Documents/Offices	Person Contacted	Affected (Yes/No)
Other Standard Plans		No
FDOT Design Manual		No
Standard Specifications	Daniel Strickland	Yes
Basis of Estimates Manual		No
Approved Product List		No
Construction Office		No
Maintenance Office		No

Implementation

FY 2026-27 (Next Cycle)

GENERAL NOTES:

1. This fence to be used generally in urban areas.

2. For supplemental information refer to Specification 550.

3. Chain link fabric, post, truss rods, tension wires, tie wires, stretcher bars, gates and all miscellaneous fittings and hardware shall meet the requirements of AASHTO and ASTM signify current reference.

4. Fence Component Options:

A. Line post options:

- (1) Galvanized steel pipe, Schedule 40- 1 1/2" nominal dia. zinc galvanized at the rate of 1.8 oz./ft².: ASTM A53 Table 2 (Grade A or B), ASTM F1083, and AASHTO M111.
- (2) Aluminum coated steel pipe: ASTM A53, Table 2 (Grade A or B): Schedule 40- 1 1/2" nominal dia., 1.90" OD; coated at the rate 0.40 oz./ft.: AASHTO M111.
- (3) Aluminum alloy pipe- 2" nominal dia.: ASTM B241 or B221, Alloy 6063, T6.
- (4) Steel H-Beam- 1 7/8" x 1 5/8": Zinc Galv. 1.8 oz./ft.: AASHTO M111 and Detail.
- (5) Aluminum alloy H-Beam- 1 7/8" x 1 5/8" Detail.
- (6) Steel C- 1 7/8" x 1 5/8": Galv.: 1.8 oz./ft. zinc: AASHTO M111; OR, 0.9 oz./ft². zinc-5% aluminum-mischmetal: ASTM F1043 and Detail.
- (7) Resistance welded steel pipe; 50,000 psi min. yield strength ASTM A569/A569M, A653/A653M or undepleted stock of discontinued A446/A446M base materials; ASTM F669 Group IV (Alternative Design); fence industry 2" OD, 1 1/2" NPS, 1,900" dec. equiv., 0.120" min. wall thick. and min. wt. 2.28 lb./ft.; with ASTM F1043 metric equivalent internal coating Types A, B, C or D and external coating Types A, B, or C; the chromate conversion coating of external Type B shall have a thickness of 15µg/in². min. and the polymer film topcoat shall have a thickness of 0.0003" min.; internal and external coatings are not restricted to the combinations of Table 2, ASTM F1043.

B. Corner, end, and pull post options:

- (1) Galvanized steel pipe, Schedule 40- 2" nominal dia. zinc galvanized at the rate of 1.8 oz./ft².: ASTM A53 Table X 2, ASTM F1083, and AASHTO M111.
- (2) Aluminum coated steel pipe: ASTM A53 steel, X 2 Tables: Schedule 40; 2" nominal dia., 2.375" OD; coated at the rate 0.40 oz./ft.: AASHTO M111.
- (3) Aluminum alloy pipe- 2 1/2" nominal dia.: ASTM B241 or B221, Alloy 6063, T6.
- (4) Resistance welded steel pipe; 50,000 psi min. yield strength ASTM A569/A569M, A653/A653M or undepleted stock of discontinued A446/A446M base materials; ASTM F669 Group IV (Alternative Design); fence industry 2 1/2" OD, 2" NPS, 2.375" dec. equiv., 0.130" min. wall thick. and min. wt. 3.117 lb./ft.; with ASTM F1043 metric equivalent internal coating Types A, B, C or D and external coating Types A, B, or C; the chromate conversion coating of external Type B shall have a thickness of 15µg/in². min. and the polymer film topcoat shall have a thickness of 0.0003" min.; internal and external coatings are not restricted to the combinations of Table 2, ASTM F1043.

C. Rail options:

- (1) Galvanized steel pipe, Schedule 40- 1 1/4" nominal dia. zinc galvanized at the rate of 1.8 oz./ft².: ASTM A53 Table X 2, ASTM F1083, and AASHTO M111.
- (2) Aluminum coated steel pipe; ASTM A53 steel, X 2 Tables: Schedule 40; 1 1/4" nominal dia., 1.660" OD; coated at the rate 0.40 oz./ft.: AASHTO M111.
- (3) Aluminum alloy pipe- 1 1/4" nominal dia.: ASTM B241 or B221, Alloy 6063, T6.
- (4) Resistance welded steel pipe; 50,000 psi min. yield strength ASTM A569/A569M, A653/A653M or undepleted stock of discontinued A446/A446M base materials; ASTM F669 Group IV (Alternative Design); fence industry 1 5/8" OD, 1 1/4" NPS, 1.660" dec. equiv., 0.111" min. wall thick. and min. wt. 1.836 lb./ft.; with ASTM F1043 metric equivalent internal coating Types A, B, C or D and external coating Types A, B, or C; the chromate conversion coating of external Type B shall have a thickness of 15µg/in². min. and the polymer film topcoat shall have a thickness of 0.0003" min.; internal and external coatings are not restricted to the combinations of Table 2, ASTM F1043.

D. Chain link fabric options (2" mesh with twisted and barbed selvage top and bottom for all options except as described in Note 10):

- (1) AASHTO M181 Type I - Zinc Coated Steel, No. 9 gage (coated wire diameter), coated at the rate of 1.8 oz./ft². (M181 Class D 2.0 oz./ft². modified to 1.8 oz./ft²).
- (2) AASHTO M181 Type II - Aluminum Coated Steel, No. 9 gage (coated wire diameter), coated at the rate of 0.40 oz./ft².
- (3) AASHTO M181 Type IV - Polyvinyl Chloride (PVC) Coated Steel, No. 9 gage (coated core wire diameter), core wire-zinc coated steel. PVC coating: M181 Class A (either extruded or extruded and bonded) or Class B (bonded). See table right. Unless the plans call for M181 standard colors medium green, dark green or black the coating color shall be soft gray matching that of No. 36622 of Federal Standard 595a.

E. Tension wire options:

- (1) Steel wire No. 7 gage zinc galvanized at the rate of 1.2 oz./ft².: AASHTO M181.
- (2) Aluminum alloy wire with a diameter of 0.1875" or larger conforming to the requirements of ASTM B211, Alloy 5056 Temper H38, or, Alclad Alloy 5056 Temper H192.
- (3) Aluminum coated steel wire No.7 gage coated at the rate of 0.040 oz./ft².: AASHTO M181.

F. Tie wire and hog ring options:

- (1) Steel wire No.9 gage zinc galvanized at the rate of 1.2 oz./ft².
- (2) Aluminum alloy wire with a diameter of 0.1443" or larger conforming to the requirements of ASTM B211, Alloy 5056 Temper H38, or, Alclad Alloy 5056 Temper H192.
- (3) Aluminum coated steel wire No. 7 gage coated at the rate of 0.040 oz./ft².

MOVED to the SPI

REWROTE: Meet the Requirements of Specification 550.

Meet the requirements of the current editions of AASHTO and ASTM references for

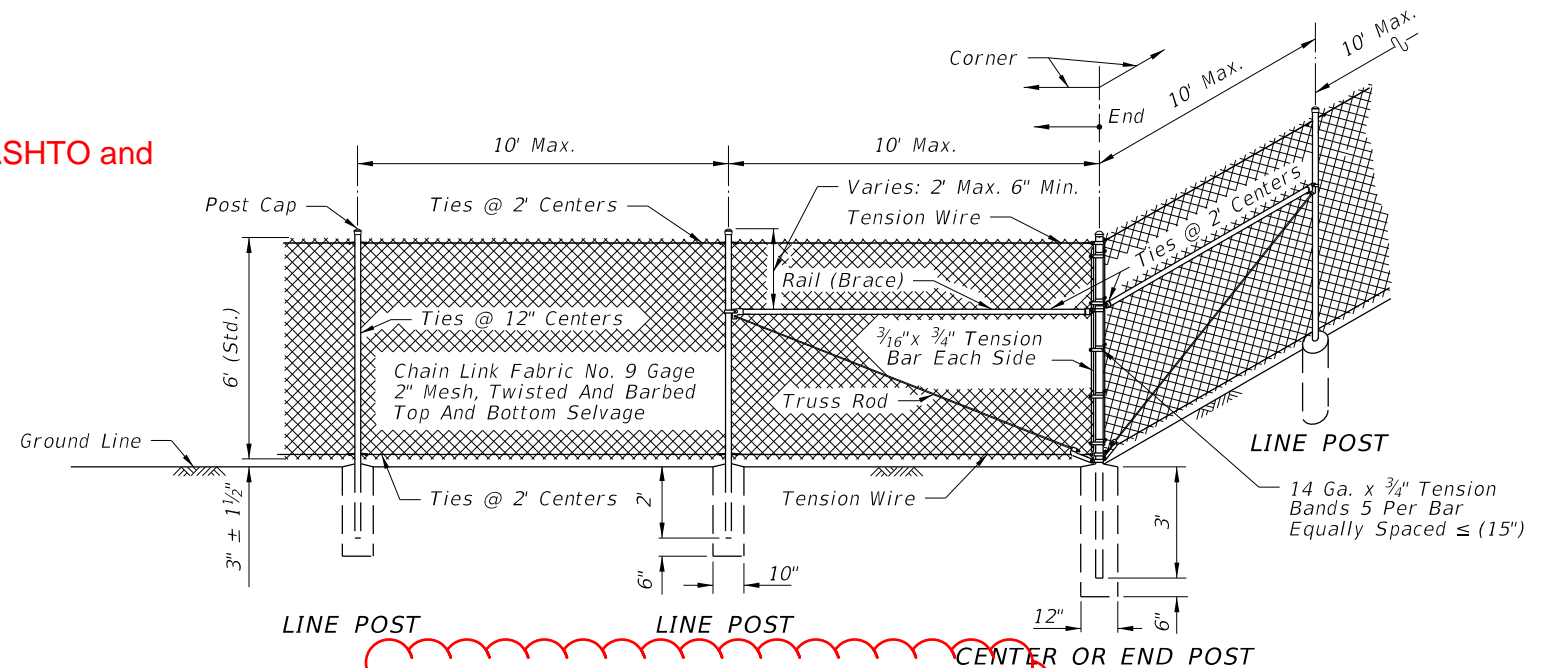

MOVED Materials Notes to the Specs

MOVED DETAILS : to Sheet 2

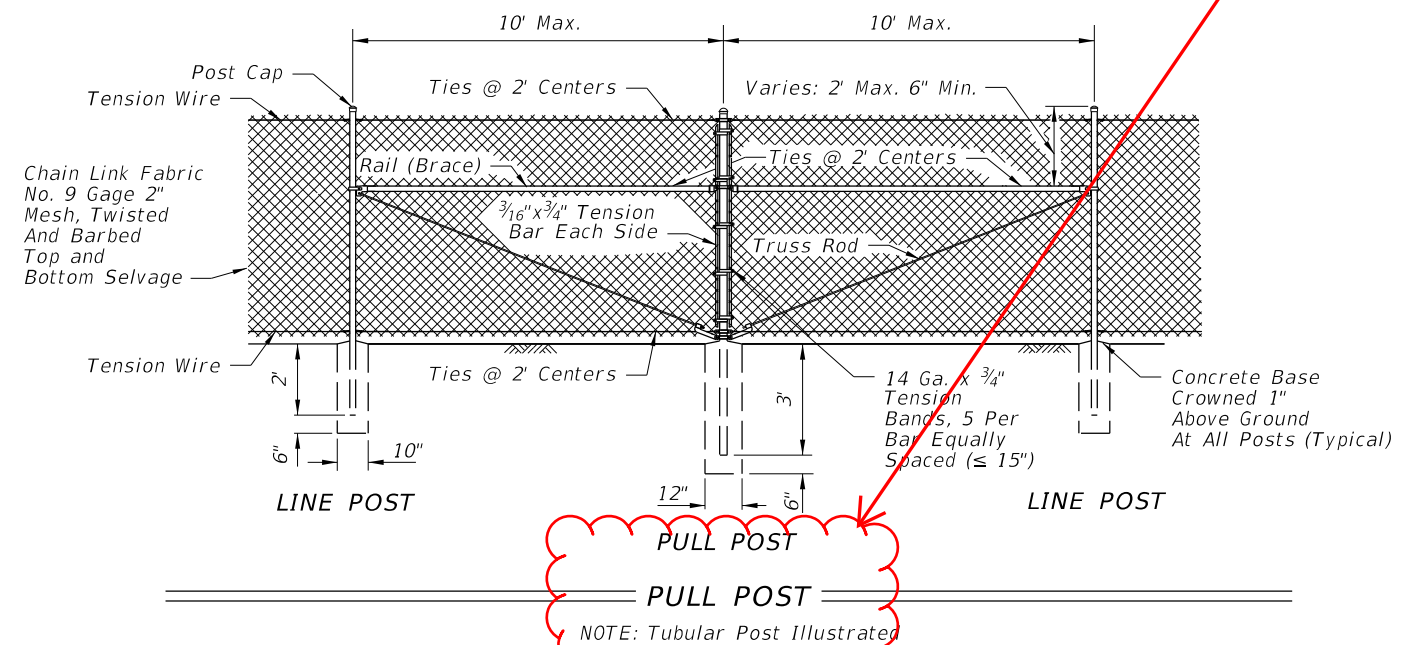

REDEVELOPED WHOLE INDEX

9/10/2024 2:05:40 PM

LAST REVISION 11/01/17 11/01/25	REVISION	DESCRIPTION:		FY 2025-26 2026-27 STANDARD PLANS	FENCE TYPE B	INDEX 550-002	SHEET 1 of 3
---------------------------------------	----------	--------------	--	---	--------------	------------------	-----------------

MOVED:
To Sheet 1

GENERAL NOTES CONTINUED

3. ~~Unless a specific material is called for in the plans the Contractor may elect to use either a single type of material or a combination of material types from the component options listed in note 4. Combinations of optional materials are restricted as follows:~~
 - (a) Only one fabric optional material will be permitted between corner and/or end post assemblies.
 - (b) Only one line post optional material will be permitted between corner and/or end post assemblies.
 - (c) Pull post assemblies shall be optional materials identical to either the line post optional material or the corner and end post assembly optional material; but, pull post assemblies shall be the same optional material between any set of corner and/or end post assemblies.
4. **Use Class NS concrete for bases**
~~Concrete for bases shall be Class NS concrete as specified in Specification 347 or a packaged, dry material meeting the requirements of a concrete under ASTM C-387. Materials for Class NS concrete may be proportioned by volume and/or by weight.~~
5. **Install 8'-6" long (Standard) line posts. Set line posts**
~~Line post shall be 8'-6" long (Standard). Line post are to be set in concrete as described above or by the following methods:~~
 - (a) In accordance with special details and/or as specifically described in the ~~Contract~~ Plans and Specifications.
 - (b) In accordance with ASTM F567 Subsections 5.4 through 5.10 as approved by the Engineer. Line post installed in accordance with Section 5.8 shall be 9'-6" long.
 - (c) Post mounted on concrete structure or solid rock shall be mounted in accordance with the base plate detail "Fence Mounting On Concrete Endwalls And Retaining Wall", Sheet 3; or, by embedment in accordance with ASTM F567 Subsection 5.5.
6. **Install End, pull and corner post assemblies shall be in concrete as detailed above for all soil conditions other than solid rock. Post within assemblies that are located on concrete structures or solid rock shall be set by base plate or by embedment as prescribed under (b) above for line post.**
Set line post assemblies
~~Line and assembly posts for 6' fence which must be lengthened due to a variation in the normal ground clearance, shall be set an additional 3" in depth for each 1' of additional ground clearance.~~
7. **Use pull posts**
~~Pull post shall be used at breaks in vertical grades of 15° or more, or at approximately 350' centers except that this maximum interval may be reduced by the Engineer on curves where the curve is greater than 3°.~~
8. **Install corner posts**
~~Corner post are to be installed at all horizontal breaks in fence at 15° or more and as required at vertical breaks over 15° as determined by the Engineer.~~
9. ~~When fence has an installed top of fabric height less than 6' knuckled top and bottom selvages shall be used unless the plans specifically identify locations for twisted selvage fabrics.~~
10. ~~Unless sliding gates or special gates are called for in the plans, all gates shall be chain link swing gates meeting the material requirements described and as approved by the Engineer. Payment shall include the gates, single or double, all necessary hardware for installation and any additional length and/or size for posts at the opening. Gates shall be paid for under the contract unit price for Fence Gates, EA.~~
11. ~~For construction purposes corner post assemblies shall consist of one corner post, two braces, two truss rods, and all necessary fittings and hardware as detailed. End post assemblies shall consist of one end post, one brace, one truss rod and all necessary fittings and hardware as detailed.~~
12. ~~In areas where there are physical constraints outside the right-of-way which restricts the fence construction, the fabric may be installed on the inside of the posts..~~

the Specifications

MOVED into the
Specifications

MOVED To Standard Plans Instructions

TYPE IV VINYL COATED FABRIC								
AASHTO M181 Table 4 Redefined As Follows								
Specified Diameter Of Metallic Coated Core Wire		Minimum Weight Of Zinc Coating		PVC Thickness Range				
				M181 Class A (Extruded Or Extruded And Bonded Coating)		M181 Class B (Bonded Coating)		
in.	mm	gage	oz./ft ² .	g/m ²	in.	mm	in.	mm
0.148	3.77	9	0.30	92	0.015 to 0.025	0.38 to 0.64	0.006 to 0.010	0.15 to 0.25

DESIGN NOTE

This index details fencing that is constructed with chain link fabric 6' (nominal) in height and with specific ground clearance. For fencing of different height or installation details, the fence shall be fully detailed in the Contract plans.

REDEVELOPED SHEET

9/10/2024 2:05:46 PM

LAST REVISION 11/01/17 11/01/25	DESCRIPTION:		FY 2025-26 STANDARD PLANS	FENCE TYPE B	INDEX 550-002	SHEET 2 of 3
---------------------------------------	--------------	---	------------------------------	--------------	------------------	-----------------

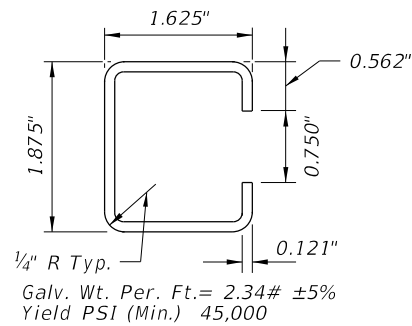

STANDARD WALL

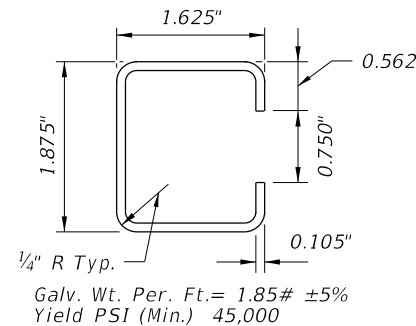

THINWALL

OPTIONAL "C" LINE POST

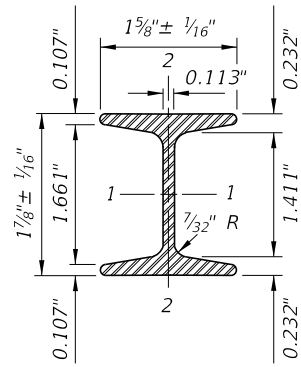

	STEEL	ALUMINUM
Area (Sq. In.)	724	724
Weight (Lb./Ft.)	2.72 ± 5% (Galv.)	0.91 ± 5%
Surface Area (SF/Ft.)	0.776	0.776
Tensile Strength (psi Min.)	80,000	30,000
Yielding Point (psi Min.)	48,000	25,000

	Axes		Axes	
	1-1	2-2	1-1	2-2
Moment Of Inertia	0.428	0.101	0.428	0.101
Section Modulus	0.456	0.124	0.456	0.124
Rad. Of Gyration	0.779	0.373	0.779	0.373

OPTIONAL 1 7/8" x 1 5/8" H-BEAM LINE POST

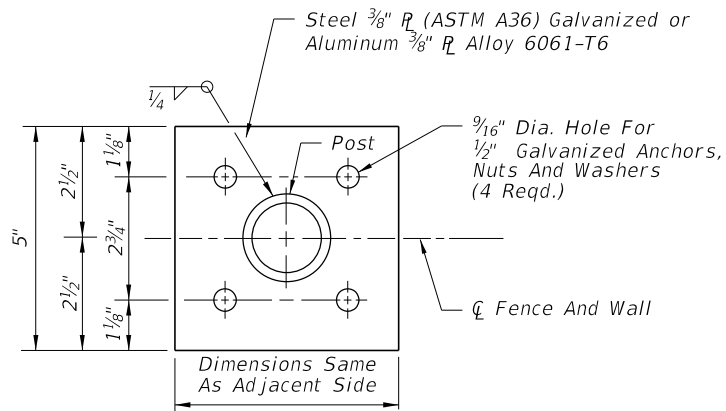

TOP VIEW
FOUR ANCHOR PLATE OPTION

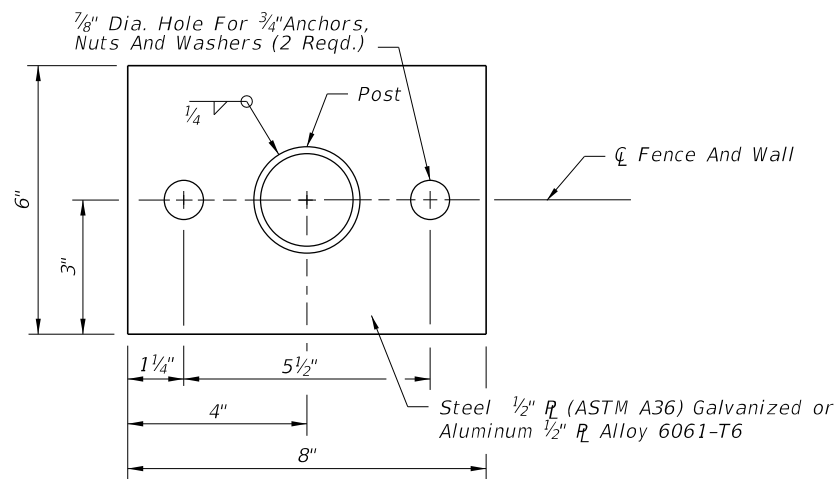

TOP VIEW
TWO ANCHOR PLATE OPTION

FENCE MOUNTING ON CONCRETE ENDWALL AND RETAINING WALLS

REDEVELOPED SHEET

FENCE POSITION AT LOCATIONS WITHOUT FRONTAGE ROADS

(REFER TO DETAIL PLANS FOR FENCE POSITION AT LOCATIONS WITH FRONTAGE ROADS)

MOVED: To Sheet 1

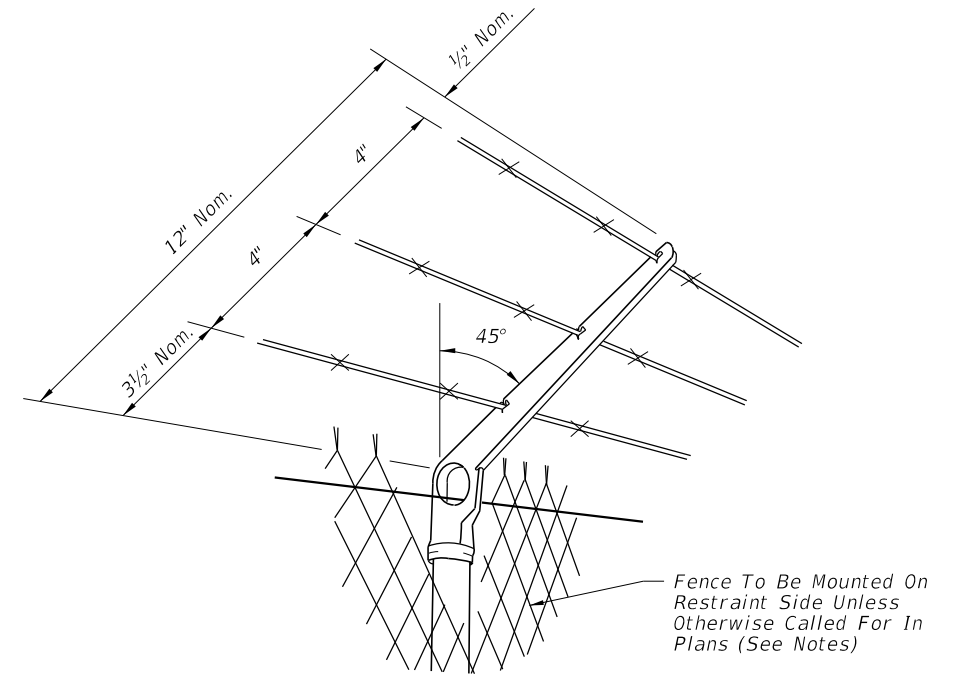

NOTES

1. Attachments to be used only when called for in the plans.
2. Attachments to extend in direction of restraint. Unless otherwise called for in plans, direction of restraint will be as follows:
 - (a.) Outward on limited access right of way line.
 - (b.) Outward on controlled access right of way line.
 - (c.) Outward from utilities and hazardous facilities located within highway right of way.
 - (d.) Outward from lateral ditches, outfalls, retention basins, canals, borrow areas and similar support facilities.
 - (e.) Inward on pedestrian ways.
3. The cap-arm shall be designed to provide a drive fit over the top of posts and to exclude moisture in posts with tubular sections.

BARB WIRE ATTACHMENT

BASE PLATE AND ANCHOR NOTES:

1. Base plate identical for line, pull, end and corner posts and shall be considered an integral part of the respective posts for basis of payment.
2. Post to be plumbed by grout shim under base plate.
3. Anchors (Galvanized Steel):
 - 12" Cast In Place, 10 1/2" Embedment: Headed Bolts, U-Bolts or Cluster Plates.
 - 8" Adhesive Anchors, 6" Min. Embedment.*
 - *Adhesive anchors shall be headless anchor bolts set in drilled holes with an Adhesive Material System in accordance with Specifications 416 and 937; drilled holes shall be 1/8" larger in diameter than the anchor bolt.
4. Expansion Bolts Not Permitted.

9/10/2024 2:05:53 PM

LAST REVISION 11/01/17 11/01/25	DESCRIPTION:	FDOT	FY 2025-26 STANDARD PLANS	FENCE TYPE B	INDEX 550-002	SHEET 3 of 3
---------------------------------------	--------------	------	------------------------------	--------------	------------------	-----------------

GENERAL NOTES:

1. For supplemental information, see Specifications 550.
2. Meet the requirements of the current editions of AASHTO and ASTM references for chain link fabric, posts, truss rods, tension wires, tie wires, stretcher bars, gates and all miscellaneous fittings and hardware.
3. Unless a specific material is called for in the plans the Contractor may elect to use either a single type of material or a combination of material types from the component options listed in the Specifications. Combinations of optional materials are restricted as follows:
 - (a) Only one fabric optional material will be permitted between corner and/or end post assemblies.
 - (b) Only one line post optional material will be permitted between corner and/or end post assemblies.
 - (c) Pull post assemblies must be optional materials identical to either the line post optional material or the corner and end post assembly optional material; but, pull post assemblies must be the same optional material between any set of corner and/or end post assemblies.
4. Use Class NS concrete for bases as specified in Specification 347 or a packaged, dry material meeting the requirements of a concrete under ASTM C-387. Materials for Class NS concrete can be proportioned by volume and/or by weight.
5. Install 8'-6" Long (Standard) line post. Set line posts in concrete as described above or by the following methods:
 - (a) In accordance with special details and/or as specifically described in the Plans and Specifications.
 - (b) In accordance with ASTM F567 Subsections 5.4 through 5.10 as approved by the Engineer. For line posts installed in accordance with Subsection 5.8 using 9'-6" long posts.
 - (c) For posts mounted on concrete structure or solid rock do so in accordance with the base plate detail "Fence Mounting On Concrete Endwall And Retaining Walls", Sheet 3; or, by embedment in accordance with ASTM F567 Subsection 5.5.

Install end, pull, and corner post assemblies in concrete as detailed above for all soil conditions other than solid rock. Post within assemblies that are located on concrete structures or solid rock must be set by base plate or by embedment as prescribed under (b) above for line post.

For 6' fence that must be lengthened due to a variation in the normal ground clearance, set line post assemblies an additional 3" in depth for each 1' of additional ground clearance.

6. Use pull post at breaks in vertical grades of 15° or more, or at approximately 350' centers except that this maximum interval may be reduced by the Engineer on curves where the curve is greater than 3°.
7. Install corner post at all horizontal breaks in fence at 15° or more and as required at vertical breaks over 15° as determined by the Engineer.
8. When fence has an installed top of fabric height less than 6' knuckled top and bottom selvages must be used unless the plans specifically identify locations for twisted selvage fabrics.
9. Unless sliding gates or special gates are called for in the plans, all gates must be chain link swing gates meeting the material requirements described and as approved by the Engineer.
10. For construction purposes corner post assemblies must consist of one corner post, two braces, two truss rods, and all necessary fittings and hardware as detailed. End post assemblies must consist of one end post, one brace, one truss rod and all necessary fittings and hardware as detailed.
11. In areas where there are physical constraints outside the right-of-way which restricts the fence construction, the fabric may be installed on the inside of the posts.
12. Install Electrical Grounds for Fence(s) that are installed within Electrical Transmission Right(s) of Way in accordance with Specification 550.

TABLE OF CONTENTS:

Sheet	Description
1	General Notes and Contents
2	Corner or End Post Details and Pull Post Details
3	C Line Post, H-Beam Line Post, Fence Mounting on Concrete Wall and Retaining Walls, and Barb Wire Attachment

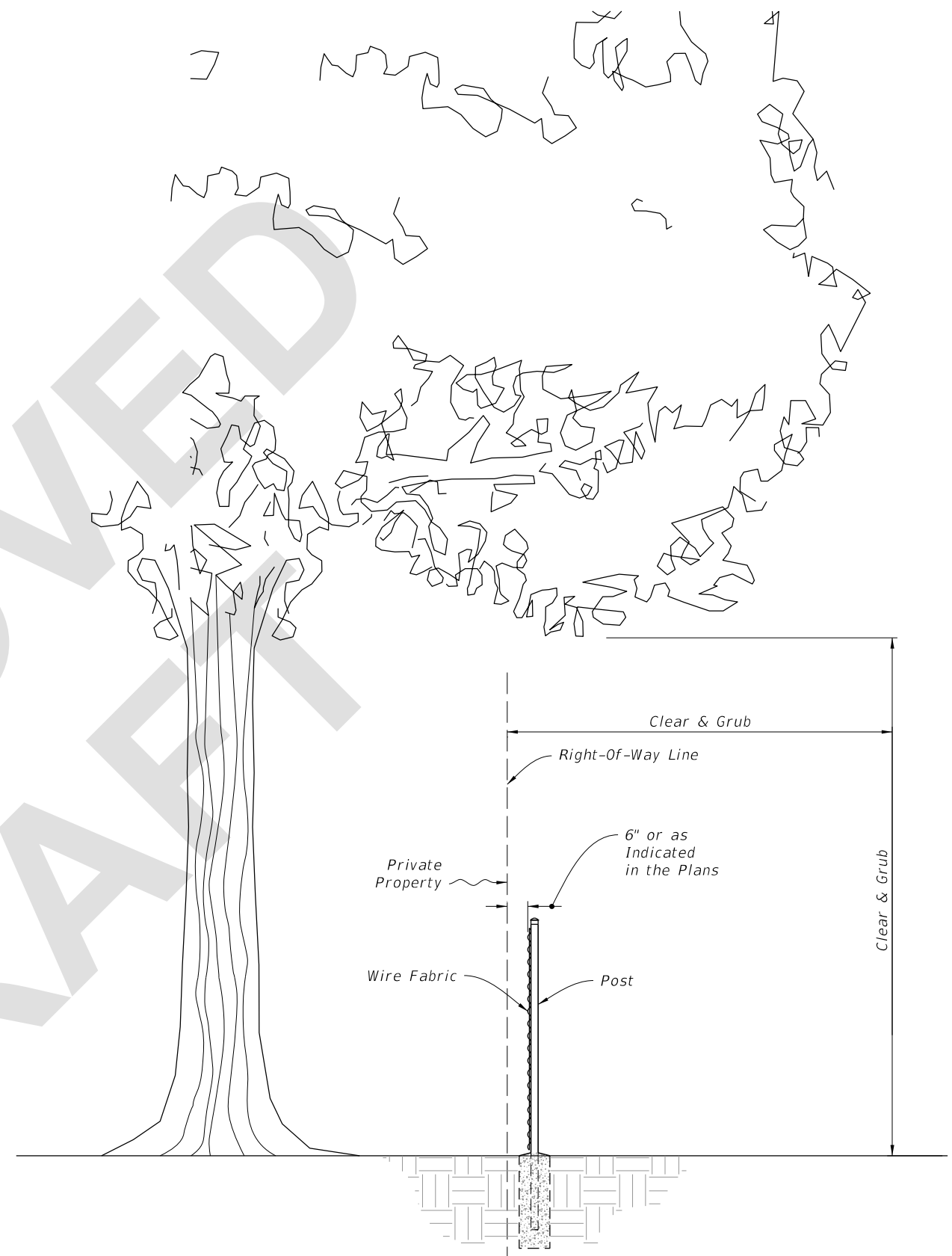

FENCE POSITION AT LOCATIONS WITHOUT FRONTAGE ROADS
 (REFER TO DETAIL PLANS FOR FENCE POSITION AT LOCATIONS WITH FRONTAGE ROADS)

8/25/2025 3:37:26 PM

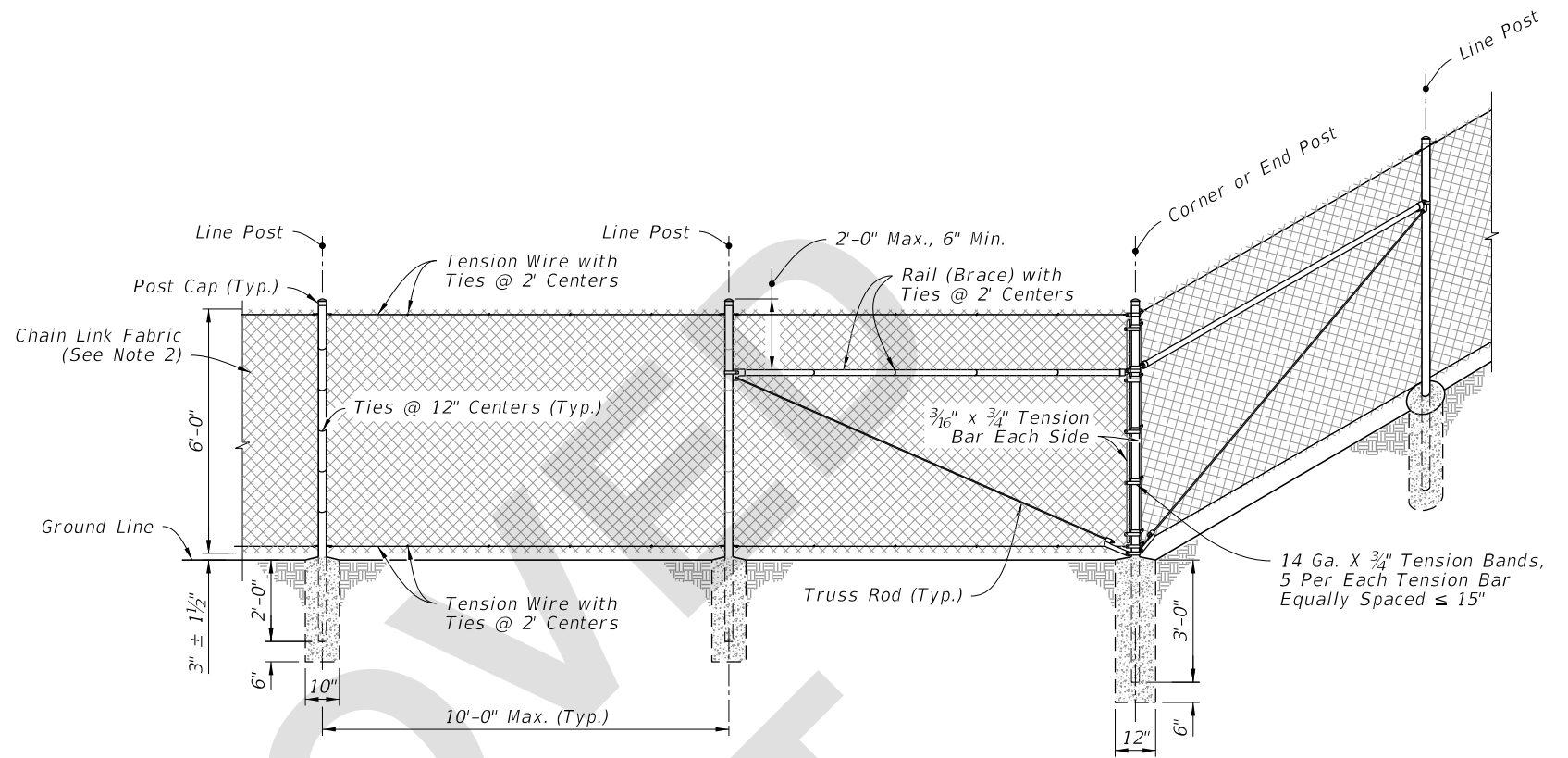

CORNER OR END POST DETAILS

NOTES:

1. Tubular post shown, others similar.
2. Install No. 9 chain link fabric mesh, twisted and barbed top and bottom selvage. See Specification 550.

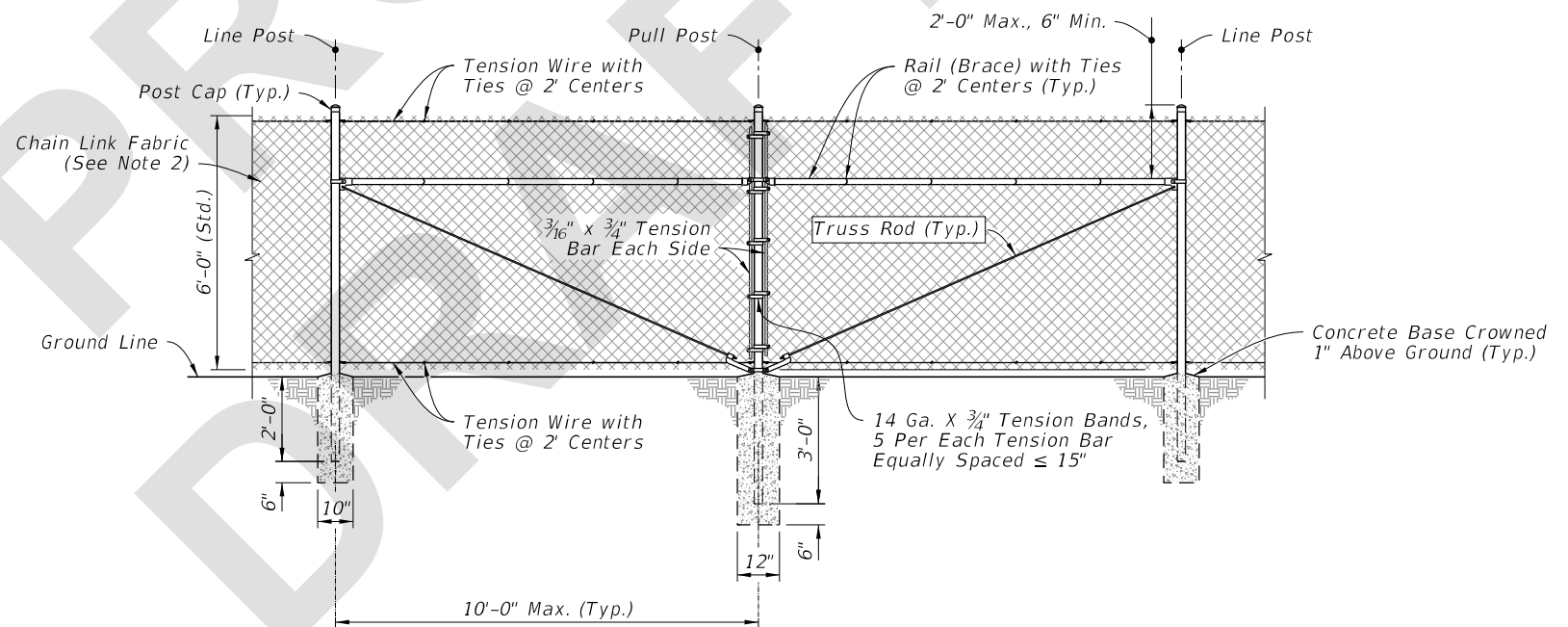

PULL POST DETAILS

CORNER OF END POST DETAILS AND PULL POST DETAILS

7/21/2025 9:40:20 AM

LAST REVISION 11/01/25	REVISION	DESCRIPTION:	 FY 2026-27 STANDARD PLANS	FENCE TYPE B	INDEX 550-002	SHEET 2 of 3
---------------------------	----------	--------------	---	--------------	------------------	-----------------

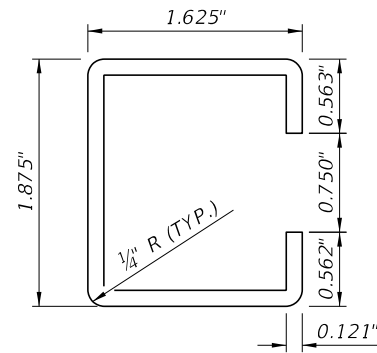

Galv. Wt. Per. Ft. = 2.34# ± 5%
Yield PSI (Min.) 45,000
STANDARD WALL

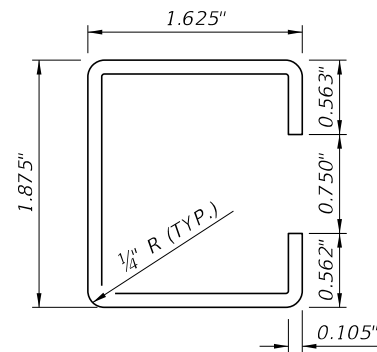

Galv. Wt. Per. Ft. = 1.85# ± 5%
Yield PSI (Min.) 45,000
THIN WALL

OPTIONAL "C" LINE POST

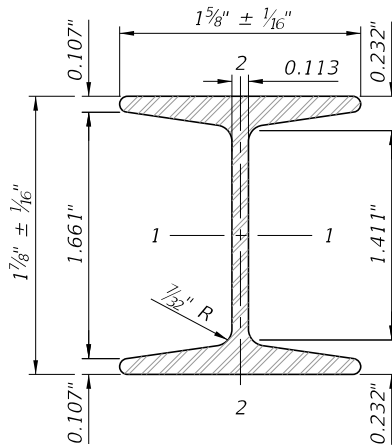

	<u>STEEL</u>	<u>ALUMINUM</u>
Area (Sq. In.)	724	724
Weight (Lb./Ft.)	2.72 ± 5% (Galv.)	0.91 ± 5%
Surface Area (SF/Ft.)	0.776	0.776
Tensile Strength (psi Min.)	80,000	30,000
Yielding Point (psi Min.)	48,000	25,000

	<u>Axes</u>		<u>Axes</u>	
	1-1	2-2	1-1	2-2
Moment of Inertia	0.428	0.101	0.428	0.101
Section Modulus	0.456	0.124	0.456	0.124
Rad. of Gyration	0.779	0.373	0.779	0.373

OPTIONAL 1 7/8" x 1 5/8" H-BEAM LINE POST

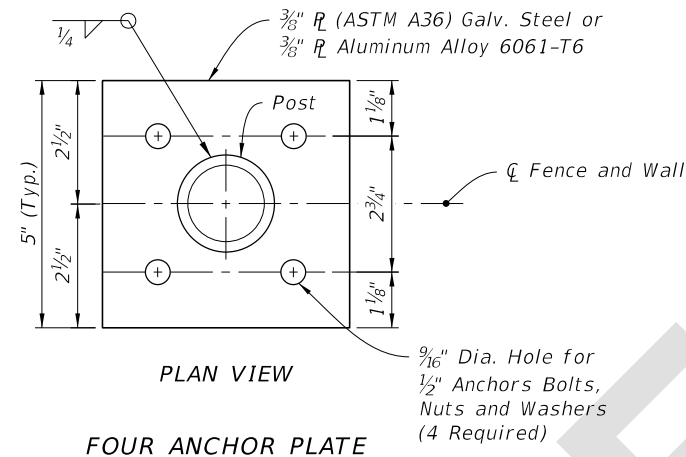

**PLAN VIEW
FOUR ANCHOR PLATE**

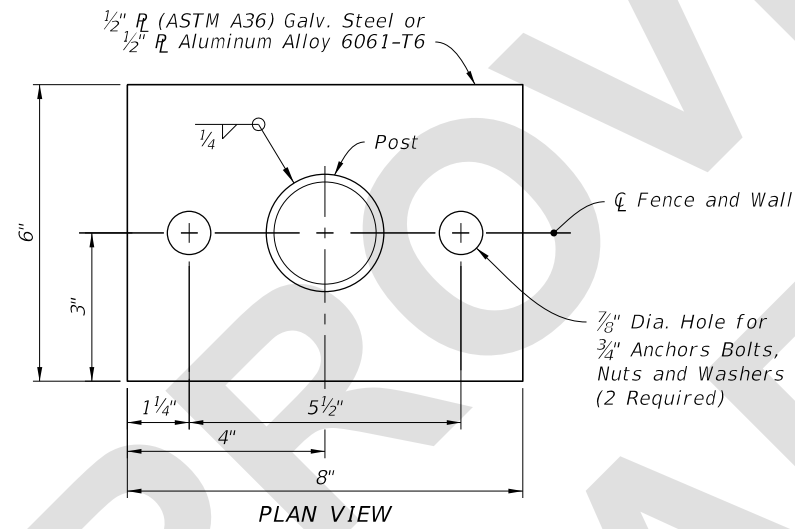

**PLAN VIEW
TWO ANCHOR PLATE**

- NOTES:**
1. Base plate identical for line, pull, end and corner posts and considered an integral part of the respective posts for basis of payment.
 2. Post to be plumbed by grout shim under base plate.
 3. Anchors (Galvanized Steel):
 - 12" Cast In Place, 10 1/2" Embedment: Headed Bolts, U-Bolts or Cluster Plates.
 - 8" Adhesive Anchors, 6" Min. Embedment. Adhesive anchors must be headless anchor bolts set in drilled holes with an Adhesive Material System in accordance with Specifications 416 and 937; drilled holes must be 1/8" larger in diameter than the anchor bolt.
 4. Expansion Bolts Not Permitted.

**FENCE MOUNTING ON CONCRETE
ENDWALL AND RETAINING WALLS**

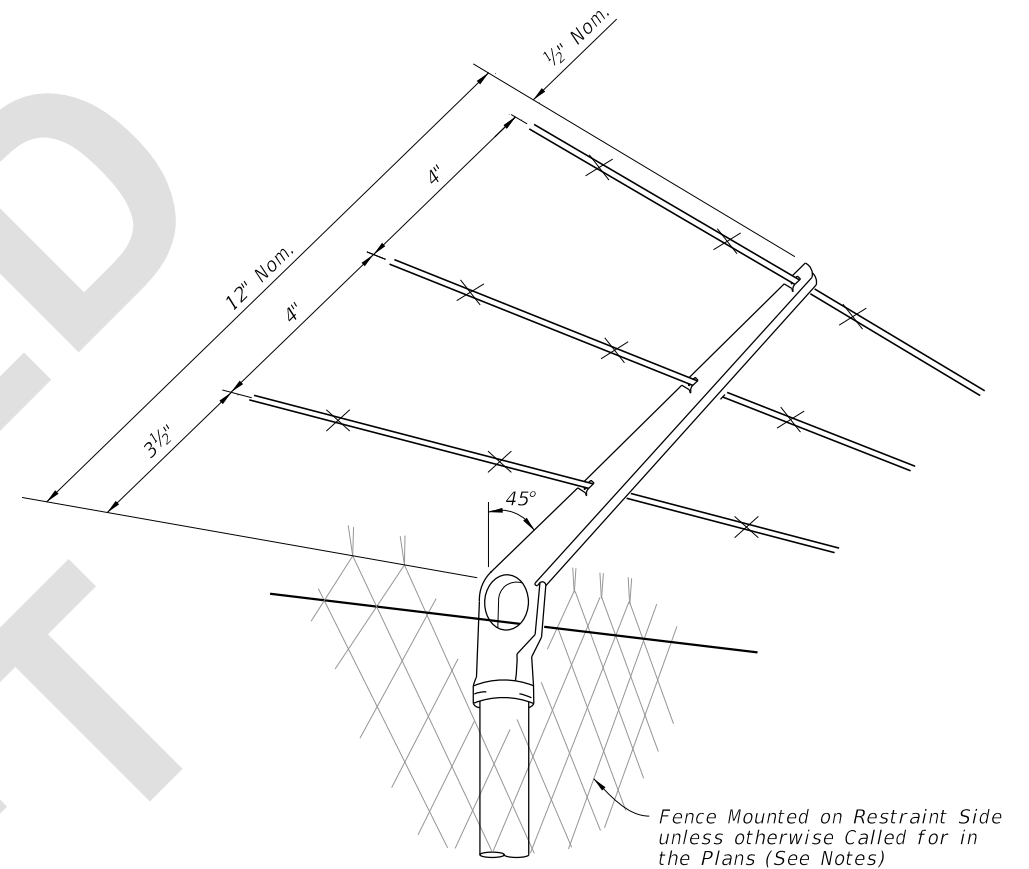

NOTES:

1. Attachments to be used only when called for in the plans.
2. Attachments to extend in direction of restraint. Unless otherwise called for in plans, direction of restraint will be as follows:
 - a. Outward on limited access right of way line.
 - b. Outward on controlled access right of way line.
 - c. Outward from utilities and hazardous facilities located within highway right of way.
 - d. Outward from lateral ditches, outfalls, retention basins, canals, borrow areas and similar support facilities.
 - e. Inward on pedestrian ways.
3. Cap-arm must be designed to provide a drive fit over the top of posts and exclude moisture in posts with tubular sections.

BARB WIRE ATTACHMENT

C LINE POST, H-BEAM LINE POST, FENCE MOUNTING ON CONCRETE WALL AND RETAINING WALLS, AND BARB WIRE ATTACHMENT

7/21/2025 9:40:28 AM

LAST REVISION 11/01/25	DESCRIPTION:		FY 2026-27 STANDARD PLANS	FENCE TYPE B	INDEX 550-002	SHEET 3 of 3
REVISION						