

Origination Form
Proposed Revisions to a Standard Plans Index

Originator:	Shishlova, Kelly	Index Number:	524-001
Date:	6/3/2025	Sheet Number(s):	1 and 2
E-mail:	kelly.shishlova@dot.state.fl.us	Index Title:	Ditch Pavement and Sodding

Summary of the changes:

Sheet 1: Update note 5 in sheet 1 to “Select and install appropriate geotextile type in accordance with Specification 514 under all ditch pavement except for miscellaneous asphalt.”
Sheet 2: Update the geotextile type for Riprap (Ditch Lining) in Table 1 in sheet 2 to “D-1 or D-2”.

Commentary/Background:

The language in section 985 of the Standard Specifications for geotextile selection was moved to section 514, therefore, requiring Note 5 in sheet 1 to be updated to remove the reference to 985. Additionally, Table 1 in sheet 2 is missing geotextile type D-1 used for Ditch Pavement (Rubble Riprap) without bedding stone.

Other Affected Documents/Offices	Person Contacted	Affected (Yes/No)
Other Standard Plans		No
FDOT Design Manual		No
Standard Specifications	Tim Holley	Yes
Basis of Estimates Manual		No
Approved Product List		No
Construction Office		No
Maintenance Office		No

Implementation

["FY-Standard Plans (Next Release)"]

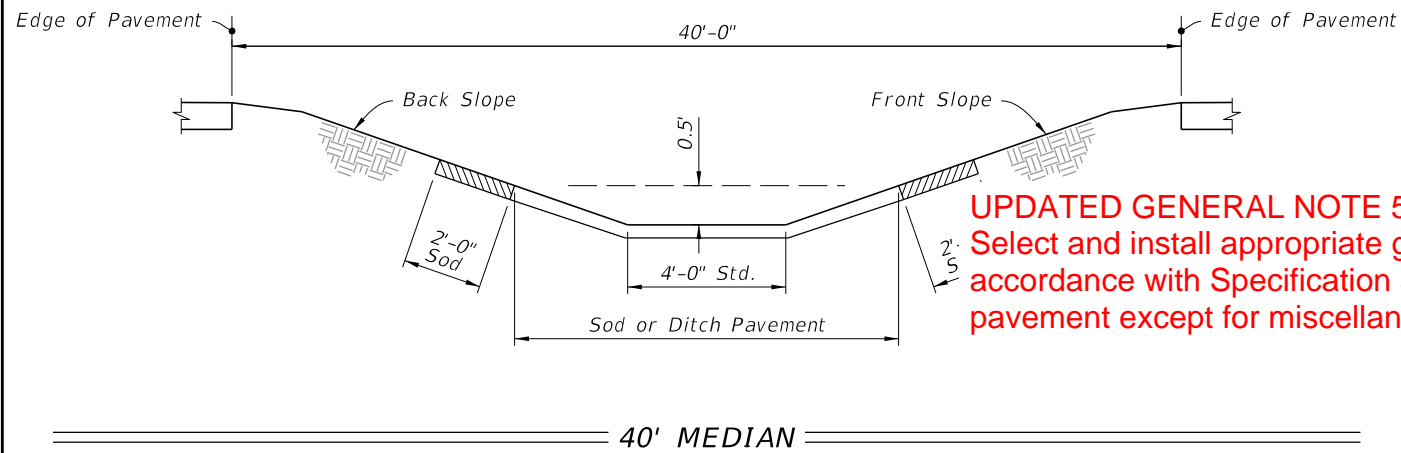
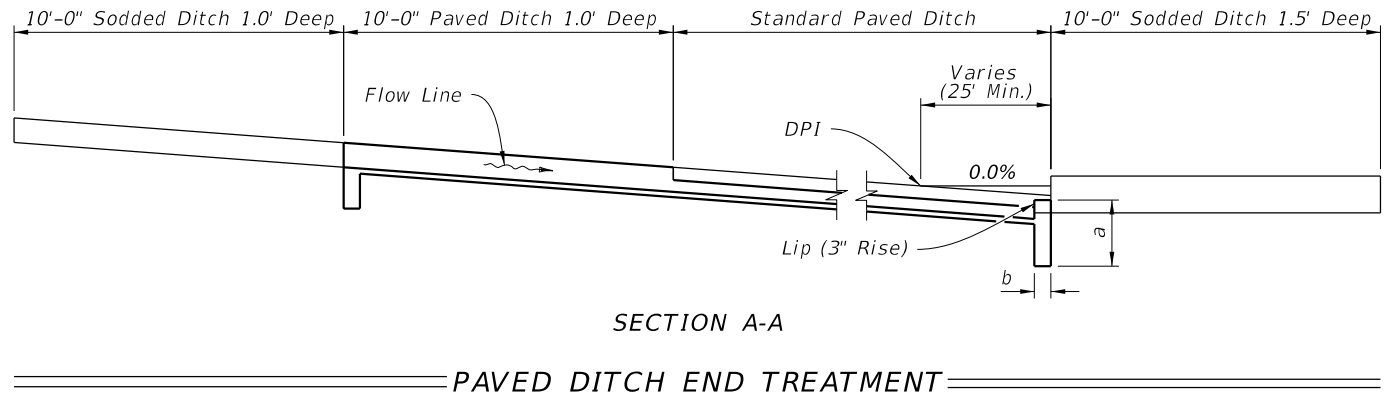
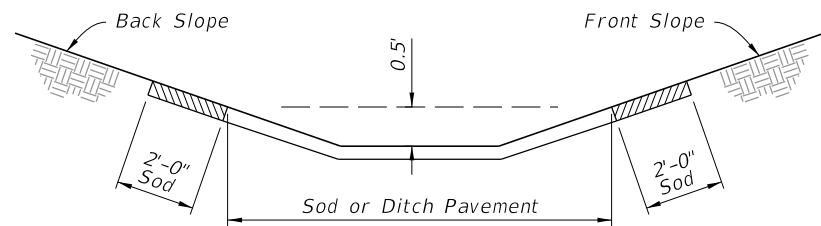
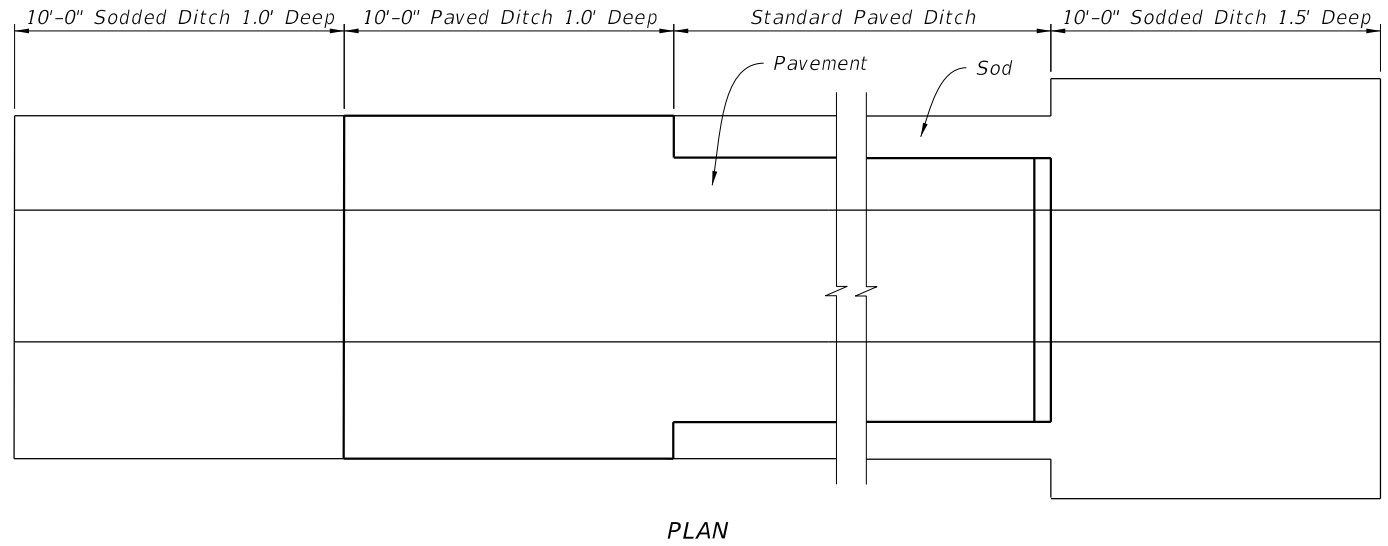
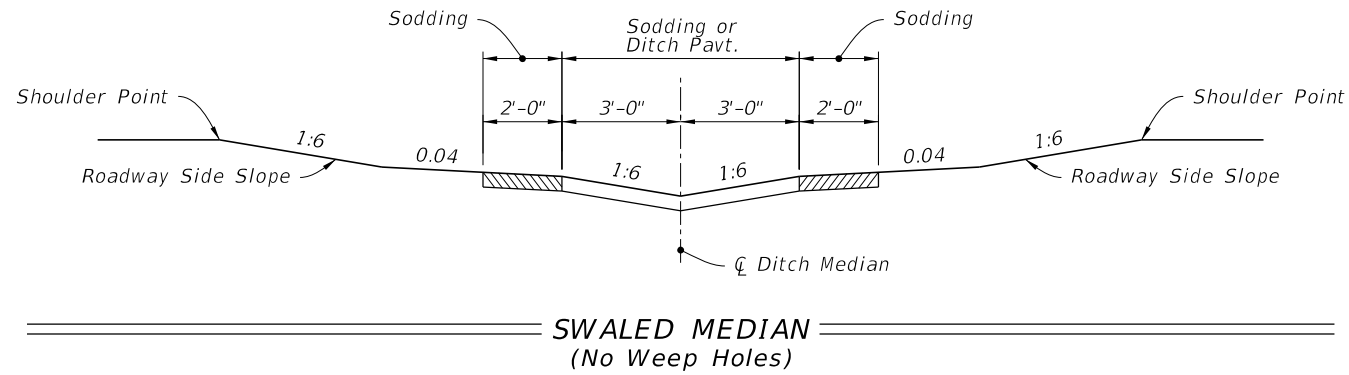

UPDATED GENERAL NOTE 5:
Select and install appropriate geotextile type in accordance with Specification 514 under all ditch pavement except for miscellaneous asphalt.

GENERAL NOTES:

1. Install type of ditch pavement shown on Plans.
2. Construct lip at the end of ditch pavement downstream of DPI or on flatter grades where there is a decrease in ditch velocity.
3. Use toewalls with all ditch paving, except adjacent to drainage structures.
4. Construct sides of paving with 1' minimum height for junction of R/W ditch spillway and lateral ditch.
5. ~~Select appropriate geotextile based on the application type referenced in Specification 985 and install in accordance with Specification 514 under all ditch pavement except for miscellaneous asphalt.~~
6. Install ditch pavement requiring reinforcement as detailed in Plans.

9/10/2024 1:42:09 PM

2026-27

LAST REVISION 11/01/23	DESCRIPTION: 11/01/25		FY 2025-26 STANDARD PLANS	DITCH PAVEMENT AND SODDING	INDEX 524-001	SHEET 1 of 3
----------------------------------	---------------------------------	--	---	----------------------------	------------------	-----------------

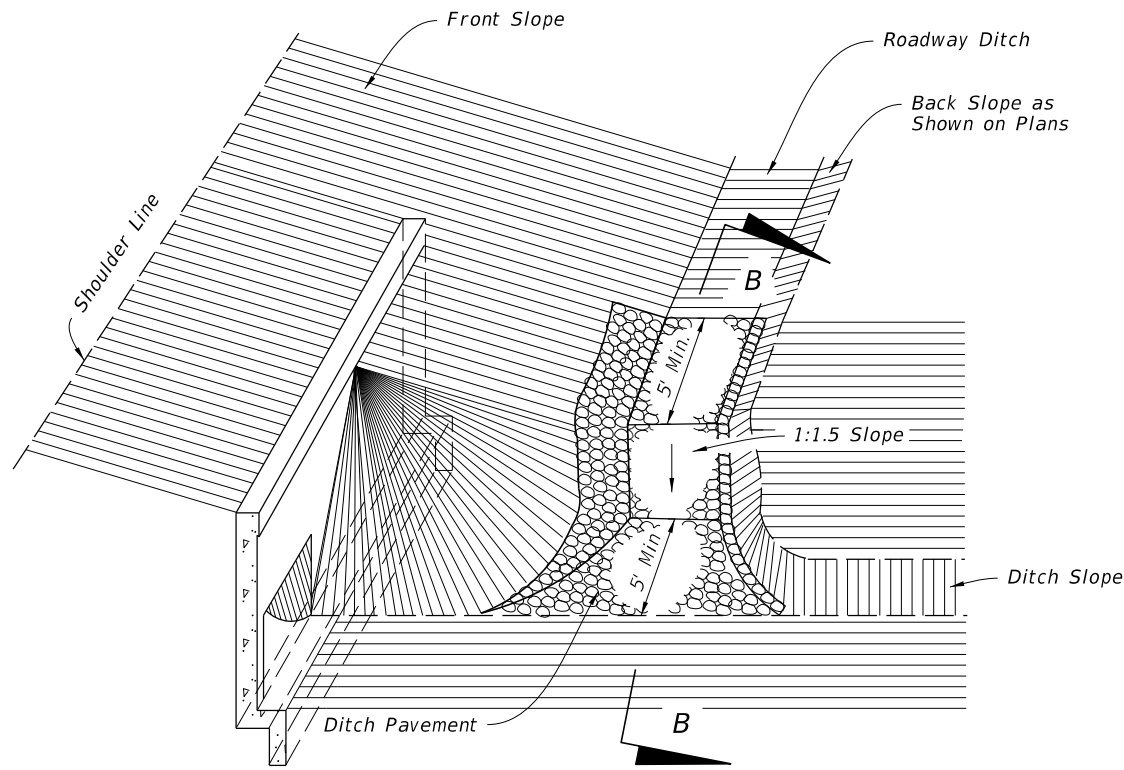

NOTE:
Miscellaneous asphalt will not be permitted for this type of construction.

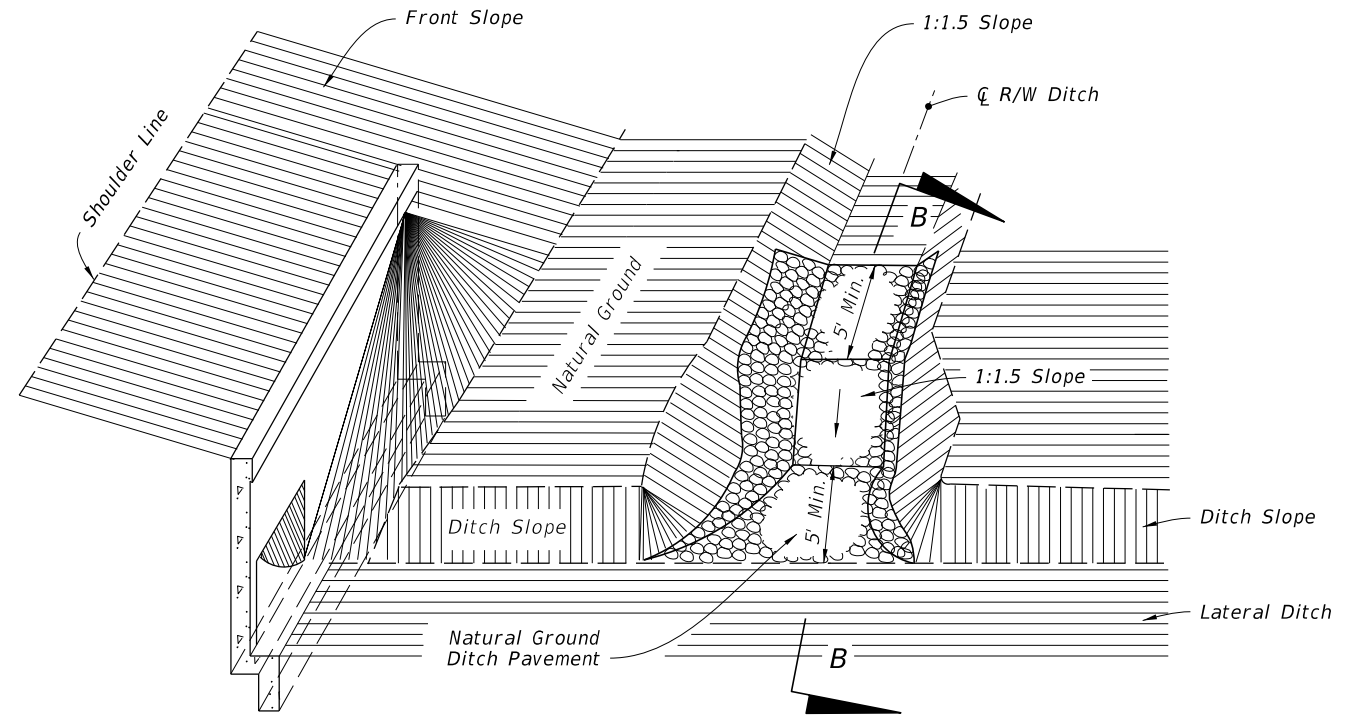

NOTE:
Miscellaneous asphalt will not be permitted for this type of construction.

JUNCTION OF ROADWAY DITCH AND LATERAL DITCH

JUNCTION OF R/W DITCH AND LATERAL DITCH

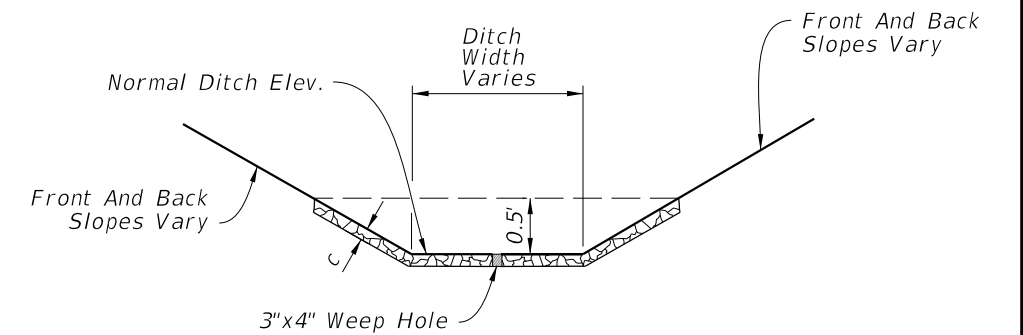
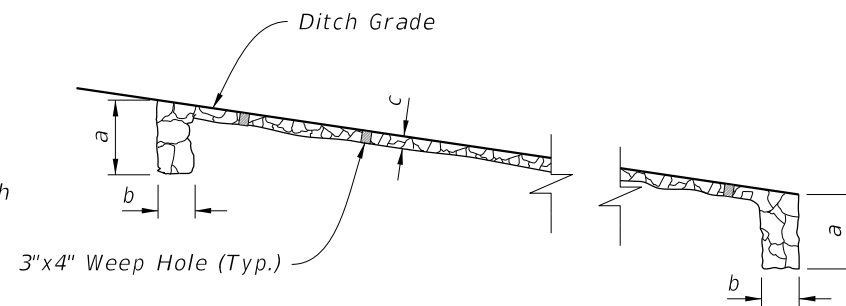
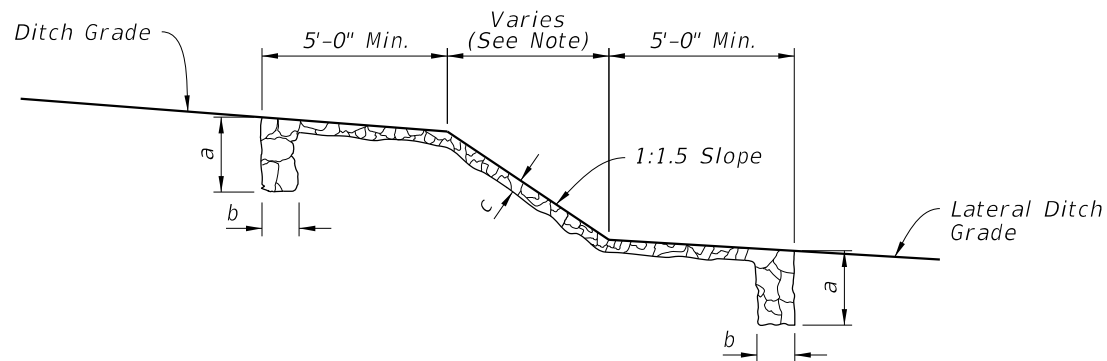

NOTE:
Do not construct weep holes in this area or 5' upstream

SECTION B-B
(As Shown)

SECTION B-B
(Locations Other Than Junction with Lateral Ditch)

TYPICAL SECTION

TABLE 1: DITCH PAVEMENT

Pavement Type	Dimensions			Geotextile Type	References & Remarks
	a	b	c		
Concrete	24"	6"	Varies	D-4	Specification 524
Miscellaneous Asphalt	24"	12"	4"	None	Specification 330
Riprap (Sand-Cement)	24"	12"	4"	D-4	Specification 530, Grouting of joints required
Riprap (Ditch Lining)	--	--	--	D-2	Specification 530

UPDATED TO: "D-1 or D-2"

2026-27

9/10/2024 1:42:16 PM

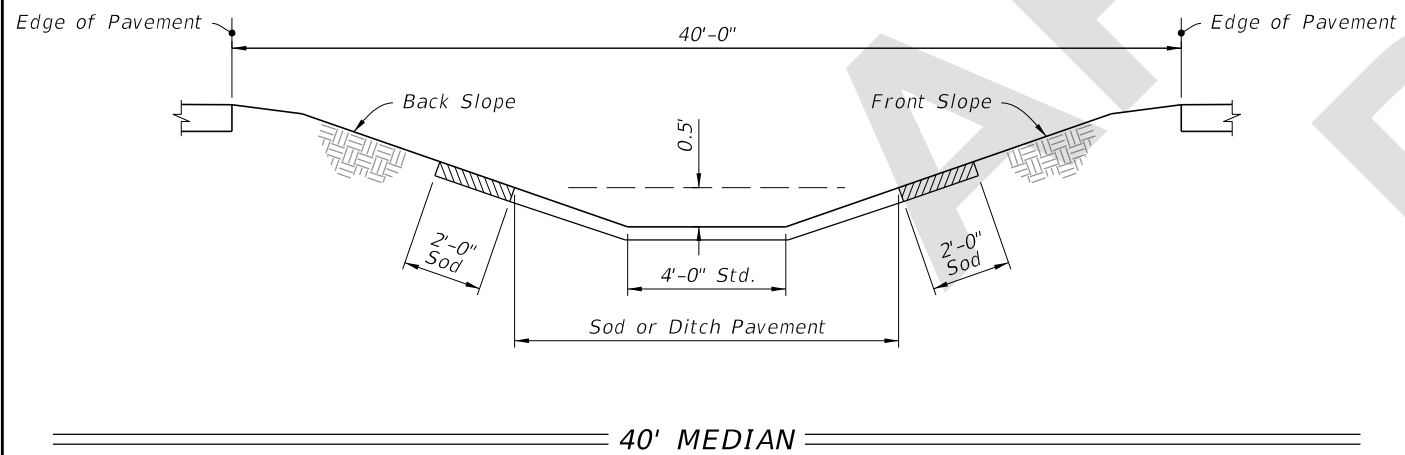
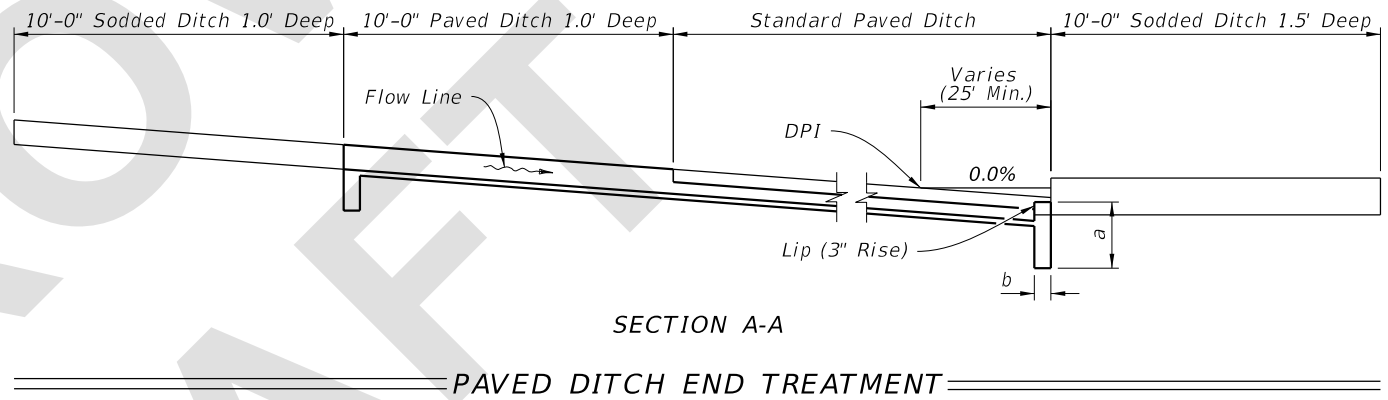
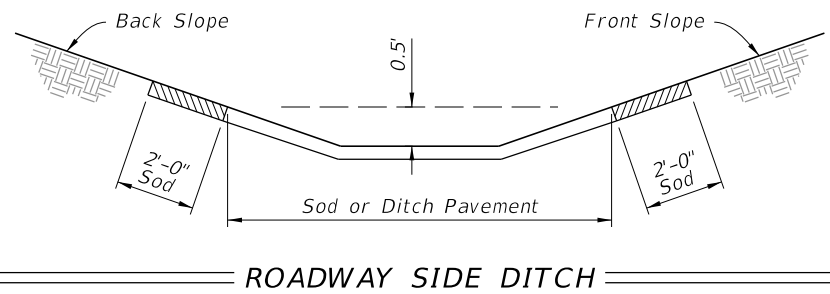
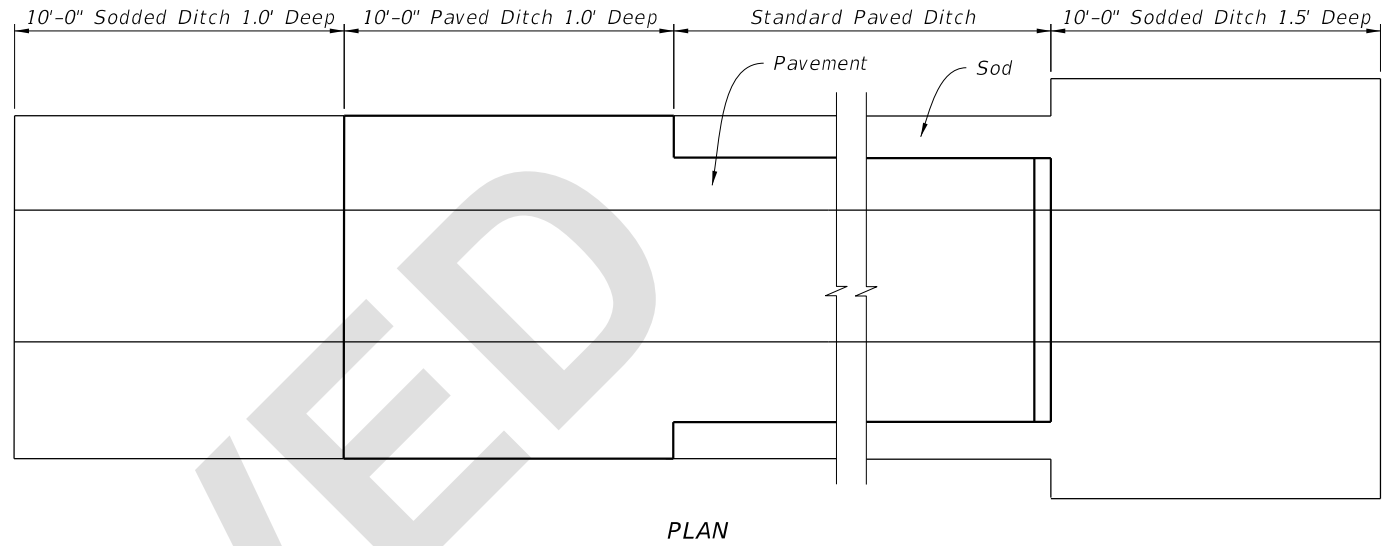
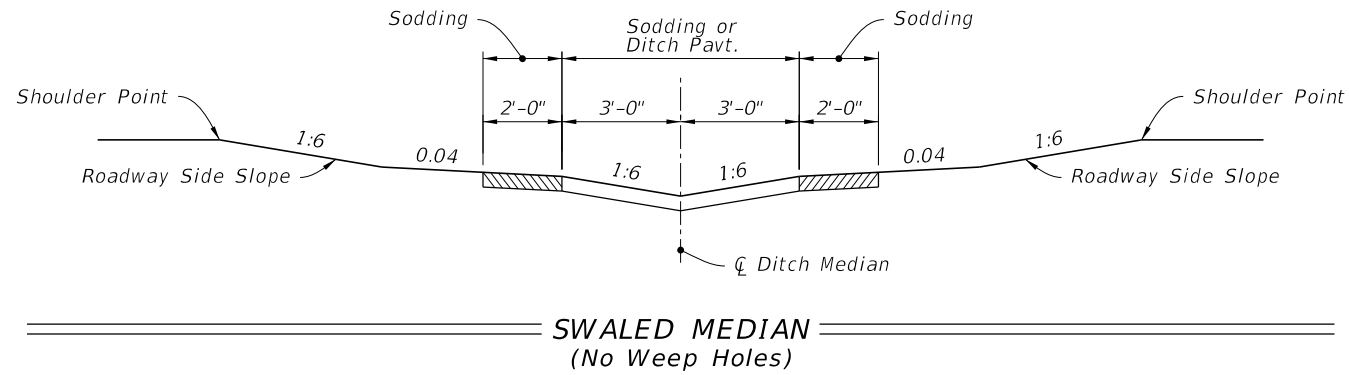

GENERAL NOTES:

1. Install type of ditch pavement shown on Plans.
2. Construct lip at the end of ditch pavement downstream of DPI or on flatter grades where there is a decrease in ditch velocity.
3. Use toewalls with all ditch paving, except adjacent to drainage structures.
4. Construct sides of paving with 1' minimum height for junction of R/W ditch spillway and lateral ditch.
5. Select and install appropriate geotextile type in accordance with Specification 514 under all ditch pavement except for miscellaneous asphalt.
6. Install ditch pavement requiring reinforcement as detailed in Plans.

6/4/2025 1:05:29 PM

LAST REVISION 11/01/25	REVISION	DESCRIPTION:	FY 2026-27 STANDARD PLANS	DITCH PAVEMENT AND SODDING	INDEX 524-001	SHEET 1 of 3
---------------------------	----------	--------------	--------------------------------------	-----------------------------------	------------------	-----------------

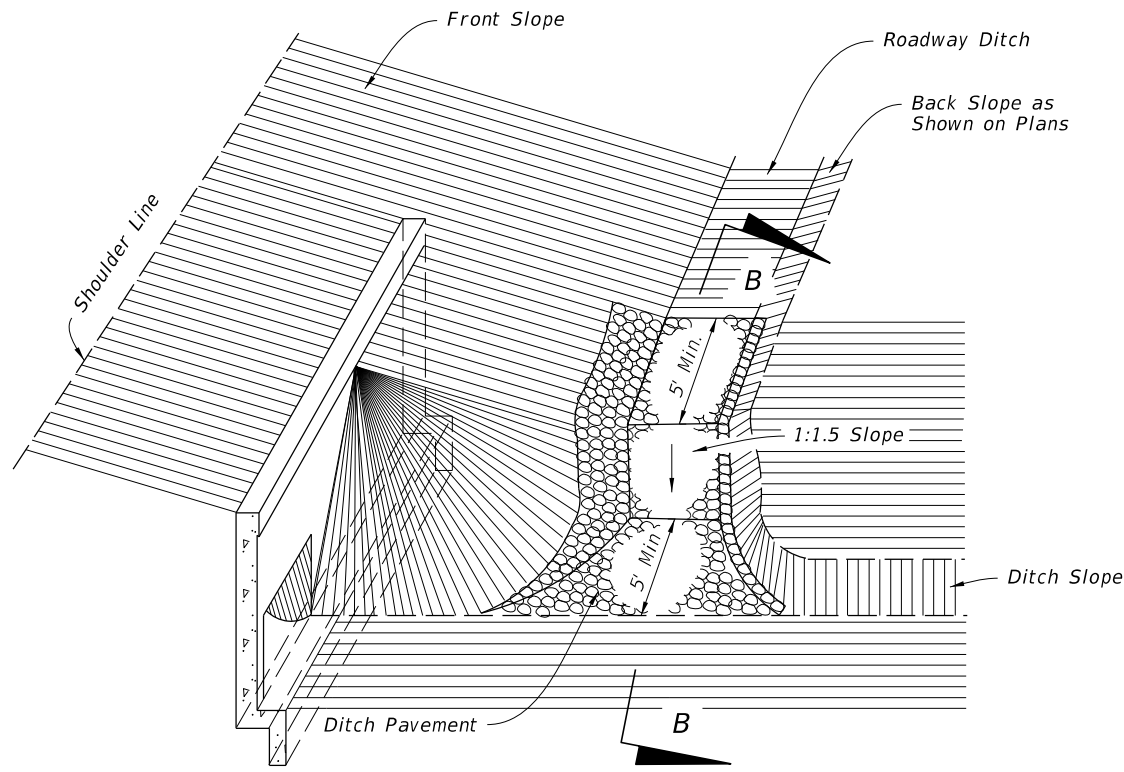

NOTE:
Miscellaneous asphalt will not be permitted for this type of construction.

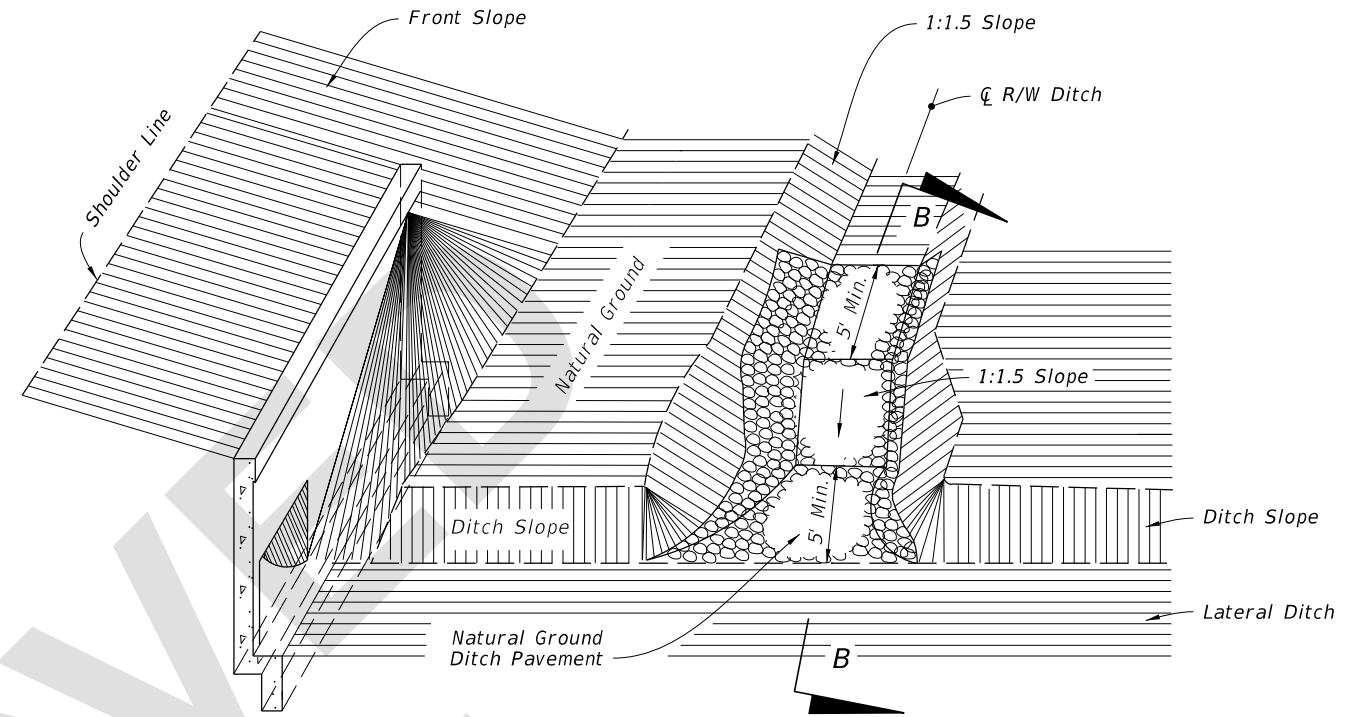

NOTE:
Miscellaneous asphalt will not be permitted for this type of construction.

JUNCTION OF ROADWAY DITCH AND LATERAL DITCH

JUNCTION OF R/W DITCH AND LATERAL DITCH

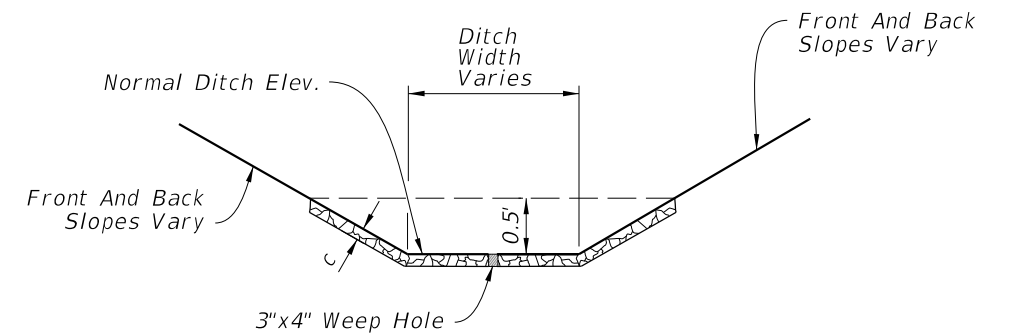
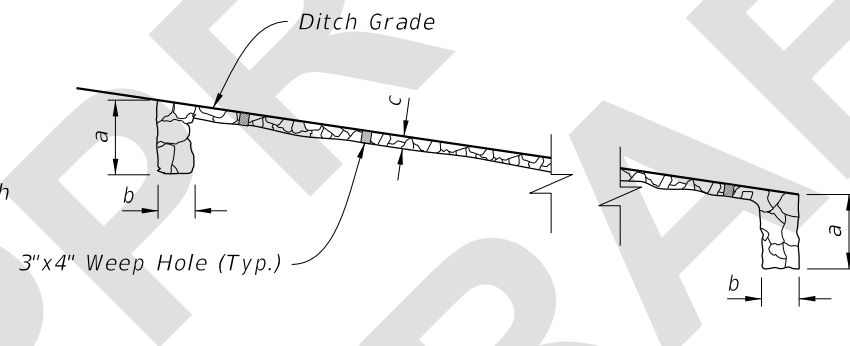
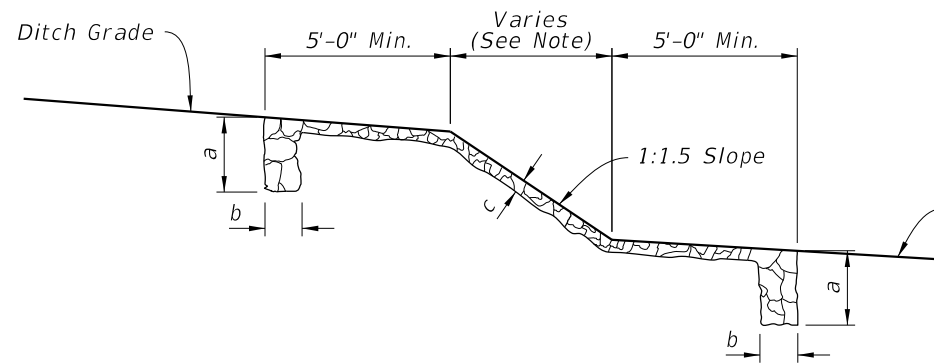

NOTE:
Do not construct weep holes in this area or 5' upstream

SECTION B-B
(As Shown)

SECTION B-B
(Locations Other Than Junction with Lateral Ditch)

TYPICAL SECTION

TABLE 1: DITCH PAVEMENT

Pavement Type	Dimensions			Geotextile Type	References & Remarks
	a	b	c		
Concrete	24"	6"	Varies	D-4	Specification 524
Miscellaneous Asphalt	24"	12"	4"	None	Specification 339
Riprap (Sand-Cement)	24"	12"	4"	D-4	Specification 530, Grouting of joints required
Riprap (Ditch Lining)	--	--	--	D-1 or D-2	Specification 530

6/4/2025 1:05:37 PM

LAST REVISION 11/01/25	REVISION	DESCRIPTION:
----------------------------------	-----------------	---------------------



**FY 2026-27
STANDARD PLANS**

DITCH PAVEMENT AND SODDING

INDEX
524-001

SHEET
2 of 3