

Origination Form
Proposed Revisions to a Standard Plans Index

Originator:	Turley, Joshua	Index Number:	521-422
Date:	1/15/2025	Sheet Number(s):	2, 3
E-mail:	Joshua.Turley@dot.state.fl.us	Index Title:	Traffic Railing - (42" Vertical Shape)

Summary of the changes:

Sheet 2: Added "Max." to the slope
Sheet 3: Added a grout plug option as an alternate detail.

Commentary/Background:

Sheet 2: Some Districts and EORs have been using a sidewalk slope of 0.015 ft/ft to help make sure the finished slope stays within the ADA limit of 0.02 ft/ft. By adding "max" to the slope detail, the EOR has the flexibility to choose the slope. The intent is to hold the barrier height constant and thus the curb height along the roadway may be slightly taller (if the slope is less).
Sheet 3: Contractors requested a more constructible and economical option that would still perform the intended function of preventing water to flow out between the open joints.

Other Affected Documents/Offices	Person Contacted	Affected (Yes/No)
Other Standard Plans		No
FDOT Design Manual		No
Standard Specifications		No
Basis of Estimates Manual		No
Approved Product List		No
Construction Office		No
Maintenance Office		No

Implementation

["FY-Standard Plans (Next Release)"]

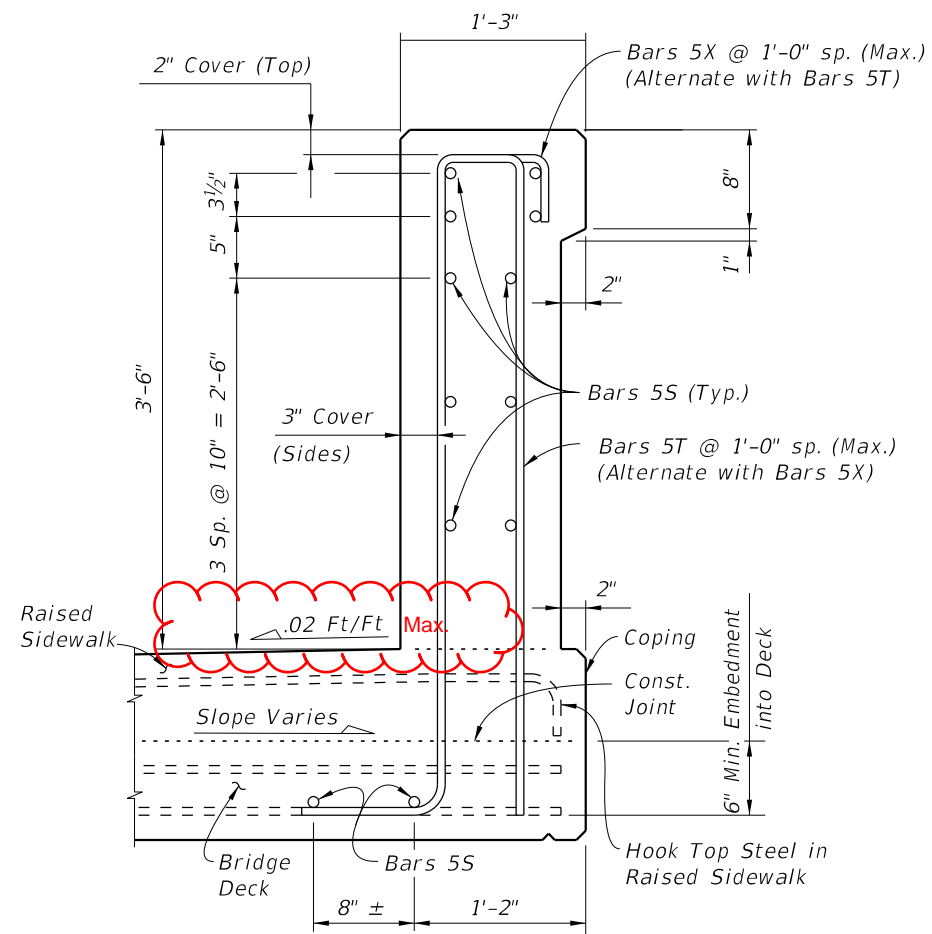

SECTION A-A
TYPICAL SECTION THRU TRAFFIC RAILING
SECTION THRU BRIDGE DECK SHOWN

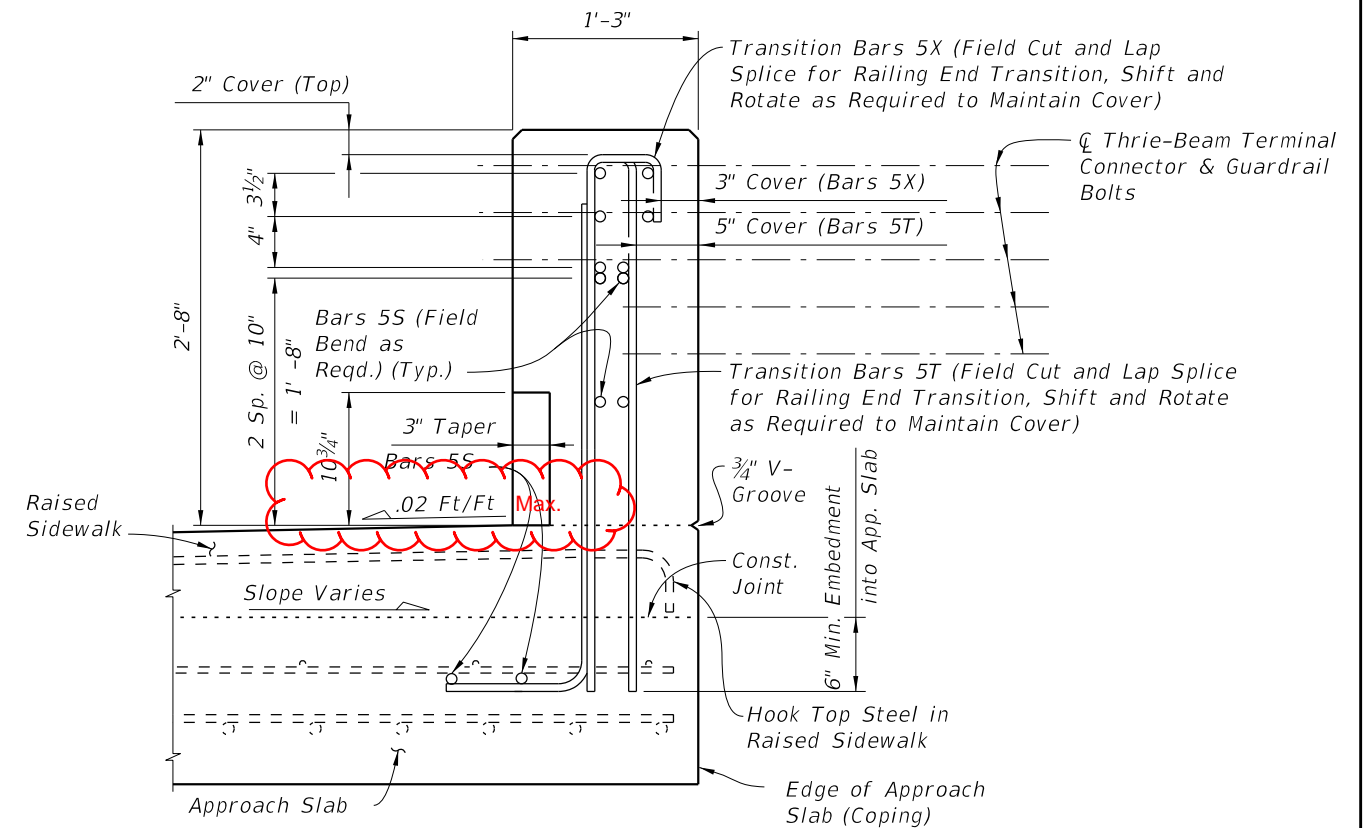

VIEW B-B
(END VIEW OF TRAFFIC RAILING END TRANSITION)
(Approach Slab shown, Retaining Wall Junction Slab similar)

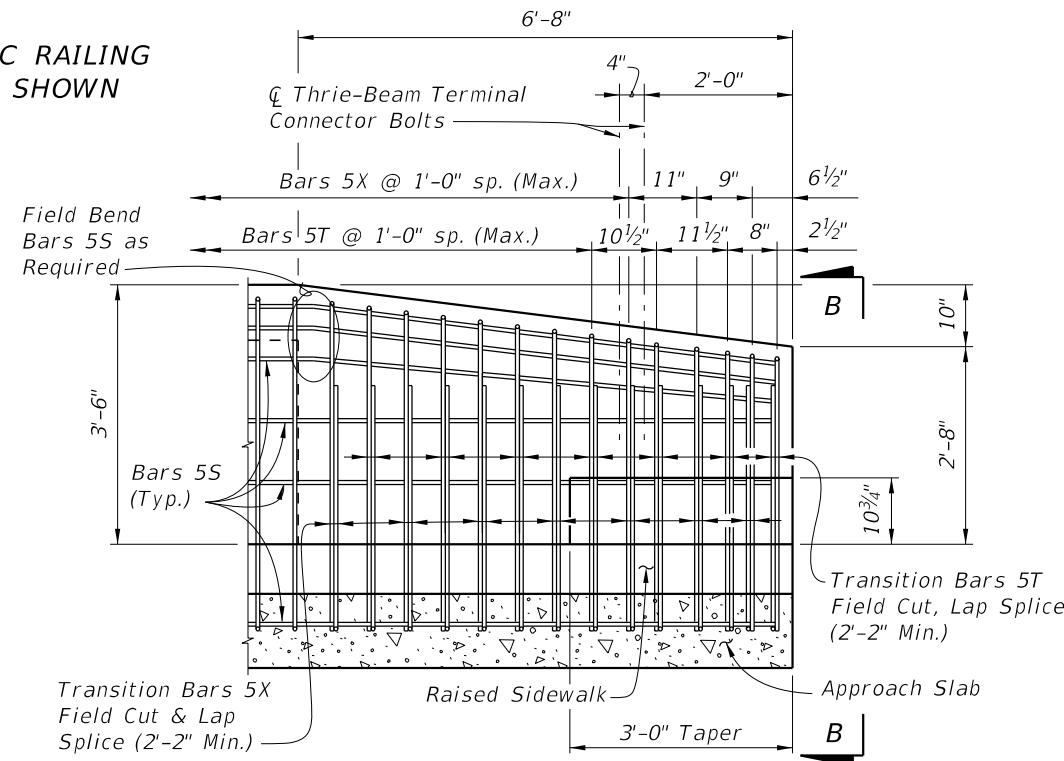

VIEW C-C
RAILING END TRANSITION
(Guardrail Not Shown For Clarity)
2026-27

CROSS REFERENCE:
For location of Section A-A, View B-B
and View C-C, see Sheet 1.

NOTES:

1. Begin placing Railing Bars 5T and 5X on Approach Slab at the railing end and proceed toward Begin or End Bridge to avoid conflict with guardrail bolt holes. If required, adjustments to the bar spacing for Bars 5T and 5X shall be made immediately adjacent to Begin or End Bridge. Cut, shift and rotate Bars 5T and 5X as required to maintain cover in Railing End Transition.
2. Omit Railing End Transition and Guardrail if Concrete Traffic Railing is used beyond the Approach Slab or Retaining Wall. See Structures Plans, Plan and Elevation Sheet and Roadway Plans. If Taper and Railing End Transition is omitted, extend Typical Section to end of the Approach Slab or limiting station on Retaining Wall, and space Bars 5T and 5X at 1'-0" (Typ.)

10/17/2024 10:28:36 AM

LAST REVISION 11/01/17 11/01/25	REVISION	DESCRIPTION:		FY 2025-26 STANDARD PLANS	TRAFFIC RAILING - (42" VERTICAL SHAPE)	INDEX 521-422	SHEET 2 of 3
---------------------------------------	----------	--------------	--	---	--	------------------	-----------------

CONVENTIONAL REINFORCING STEEL BENDING DIAGRAMS

BILL OF REINFORCING STEEL		
MARK	SIZE	LENGTH
S	5	As Req'd.
T	5	10'-8"
X	5	6'-9"

ROADWAY CROSS-SLOPE	ØA	
	LOW GUTTER	HIGH GUTTER
0% to 2%		
2% to 6%		
6% to 10%		

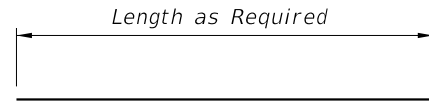

BAR 5S

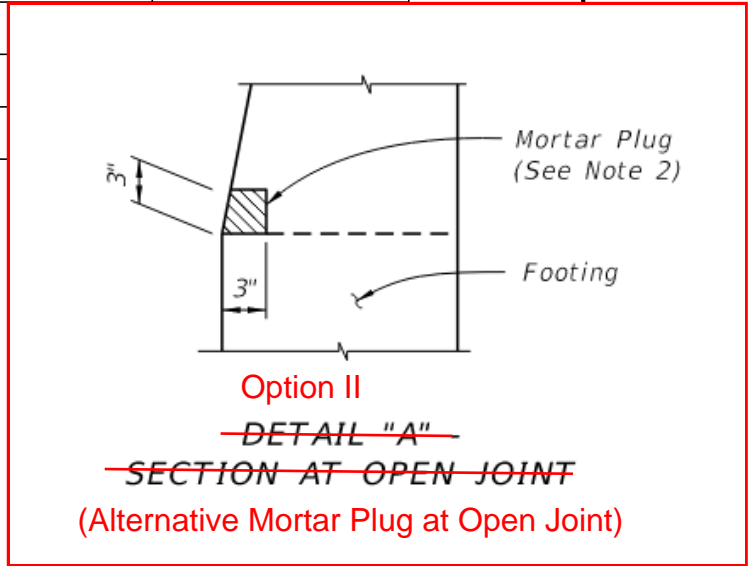

Option II
~~DETAIL "A" SECTION AT OPEN JOINT~~
(Alternative Mortar Plug at Open Joint)

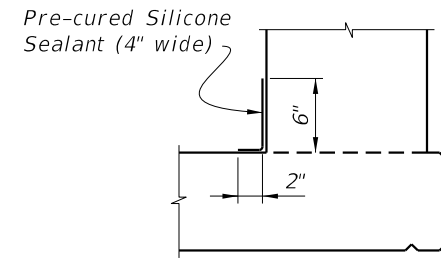

Option I
~~DETAIL "A" SECTION AT INTERMEDIATE OPEN JOINT~~

INTERMEDIATE JOINT SEAL NOTES:

- At Intermediate Open Joints, seal the lower 6" portion of the open joint with Pre-cured Silicone Sealant in accordance with Specification Section 932.
- Apply sealant prior to any Class V finish coating and remove all curing compound and loose material from the surface prior to application of bonding agent.
- The cost of the Pre-cured Silicone Sealant shall be included in the Contract Unit Price for the Traffic Railing.
- As an alternative option, a mortar plug may be used to seal the joint as shown in the mortar plug detail and in accordance with Specification Section 400.

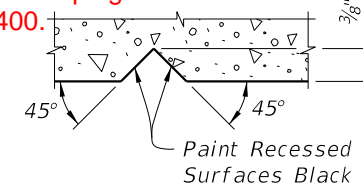

SECTION THRU RECESSED "V" GROOVE TO FORM INSCRIBED LETTERS AND FIGURES

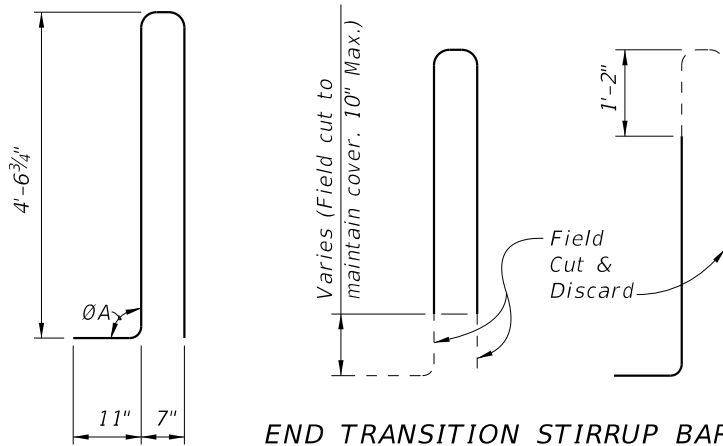

END TRANSITION STIRRUP BARS 5T
To Be Field Cut (7 of each required per Railing End Transition)

STIRRUP BAR 5T

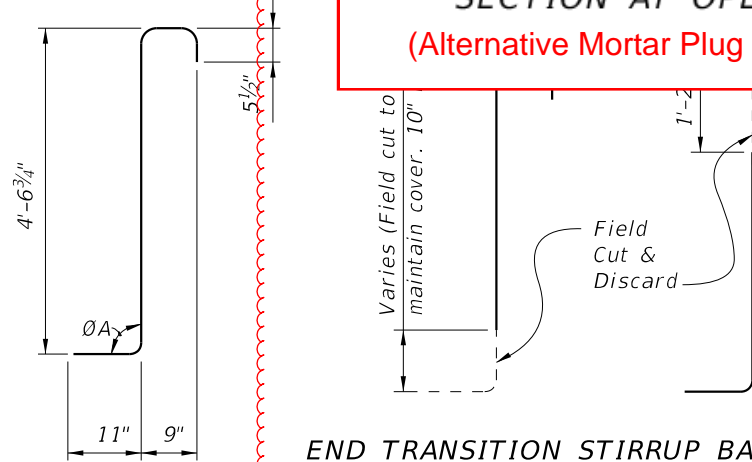

END TRANSITION STIRRUP BARS 5X
To Be Field Cut (7 of each required per Railing End Transition)

STIRRUP BAR 5X

REINFORCING STEEL NOTES:

- All bar dimensions in the bending diagrams are out to out.
- The 4'-6 3/4" vertical dimension shown for Bars 5T and 5X is based on a bridge deck with a 6" thick x 6' wide raised sidewalk at low side of deck, 2% deck cross slope and a counter 2% raised sidewalk cross slope. If the raised sidewalk thickness, width or cross slope vary from the above amounts, adjust this dimension accordingly to achieve a 6" minimum embedment into the bridge deck. See Structures Plans, Superstructure and Approach Slab Sheets.
- The reinforcement for the railing on a retaining wall shall be the same as detailed above with ØA = 90°.
- All reinforcing steel at the open joints shall have a 2" minimum cover.
- Bars 5S may be continuous or spliced at the construction joints. Bar splices for Bars 5S shall be a minimum of 2'-2".
- The Contractor may utilize Welded Wire Reinforcement (WWR) when approved by the Engineer. WWR must consist of Deformed wire meeting the requirements of Specification Section 931.

ESTIMATED TRAFFIC RAILING QUANTITIES		
ITEM	UNIT	QUANTITY
Concrete	CY/LF	0.145
Reinforcing Steel	LB/LF	30.68

(The above quantities are based on a 6" thick x 6' wide raised sidewalk at low side of deck, 2% deck cross slope and counter 2% sidewalk cross slope)

2026-27

FY ~~2025-26~~
STANDARD PLANS

TRAFFIC RAILING - (42" VERTICAL SHAPE)

INDEX
521-422

SHEET
3 of 3

10/17/2024 10:28:43 AM

LAST REVISION
11/01/17
11/01/25

DESCRIPTION:



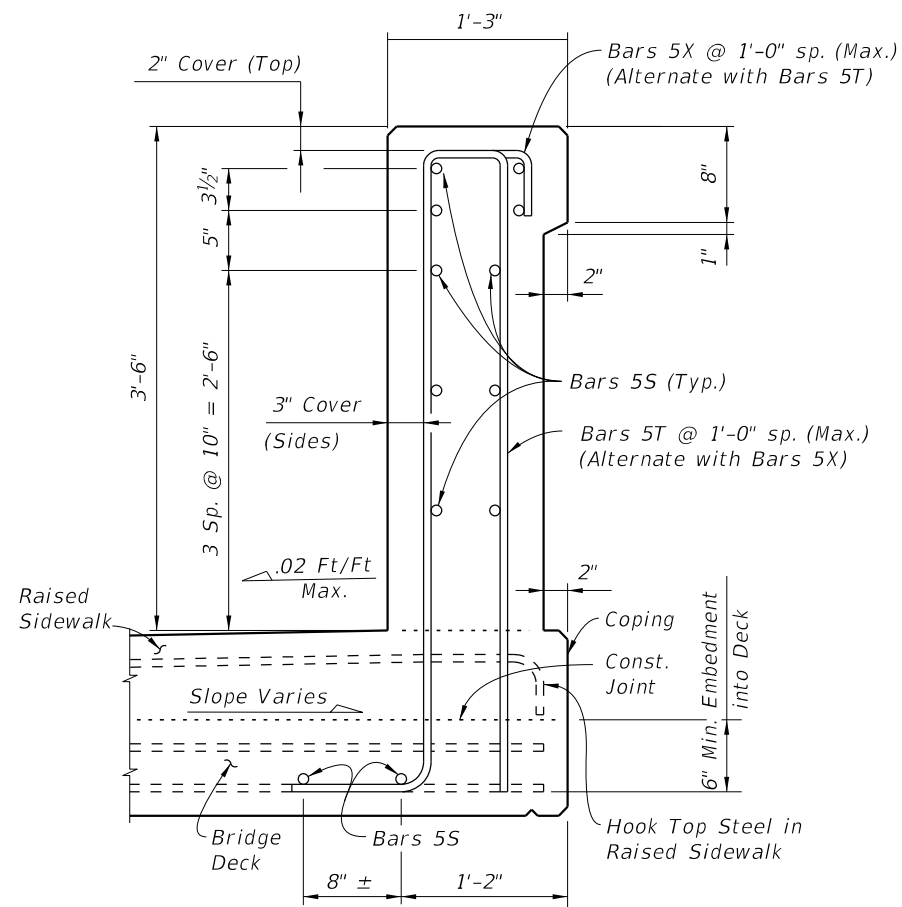

SECTION A-A
TYPICAL SECTION THRU TRAFFIC RAILING
SECTION THRU BRIDGE DECK SHOWN

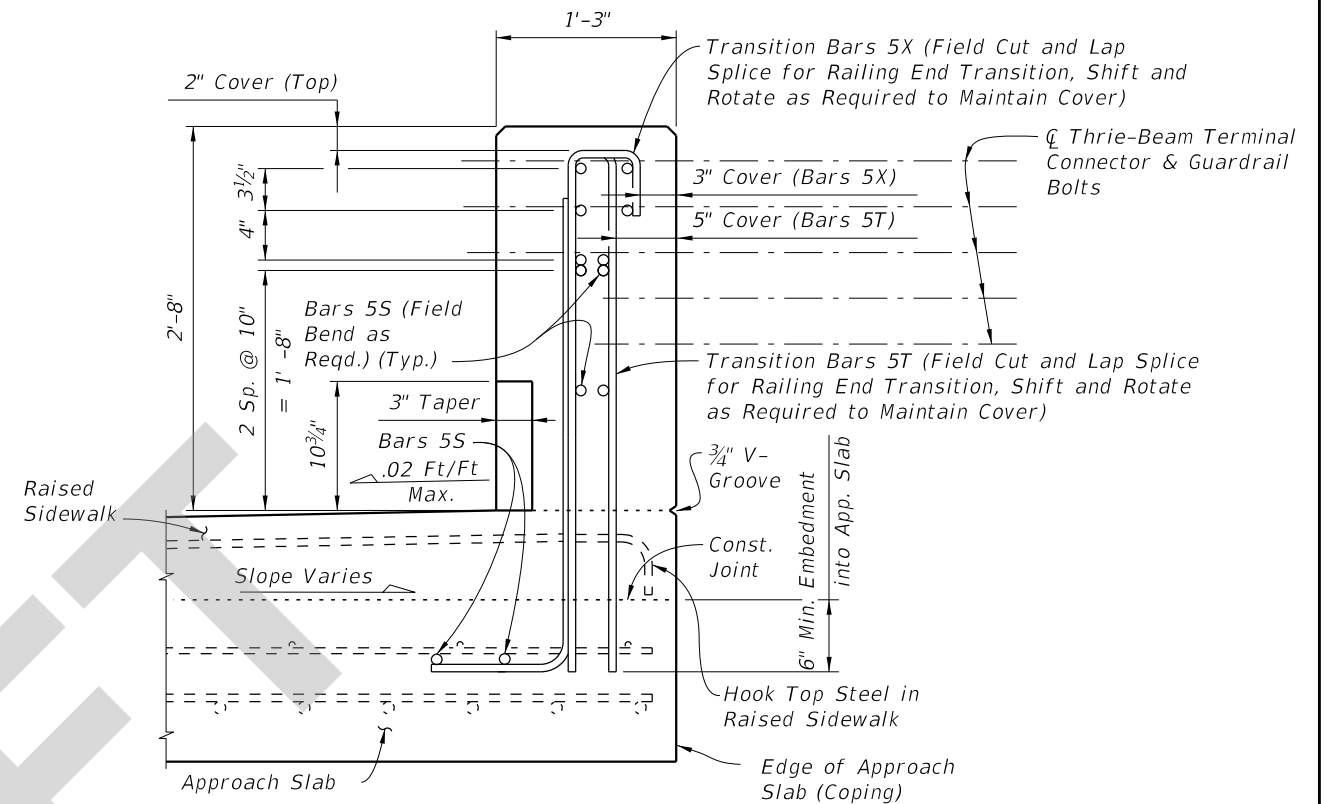

VIEW B-B
(END VIEW OF TRAFFIC RAILING END TRANSITION)
(Approach Slab shown, Retaining Wall Junction Slab similar)

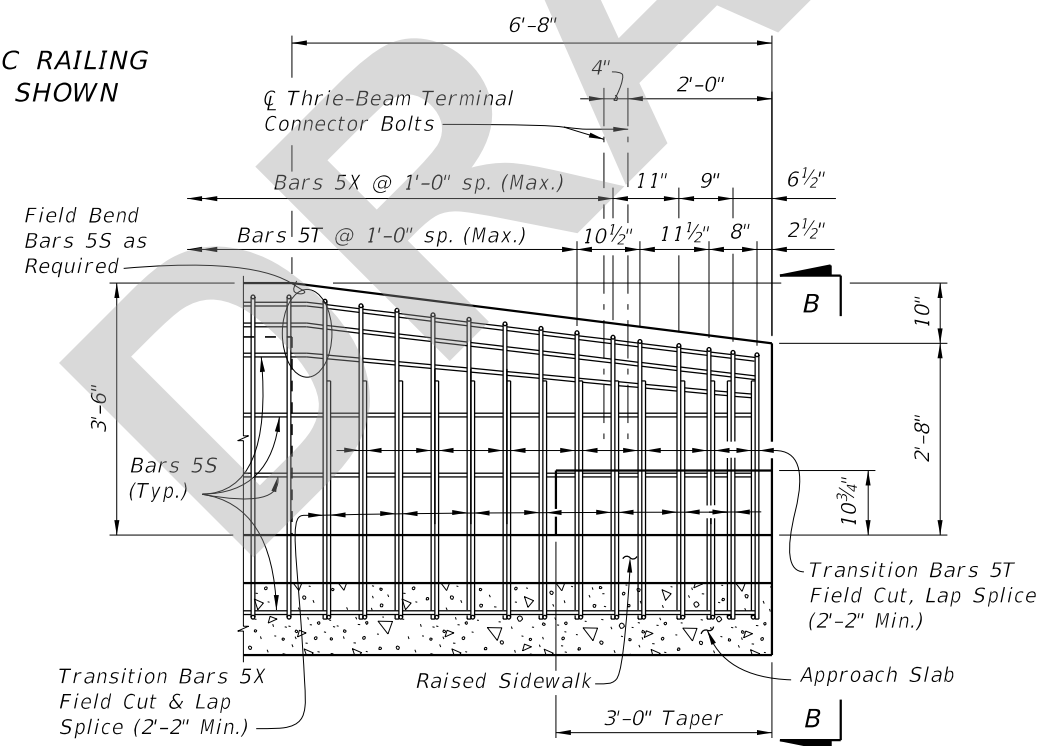

VIEW C-C
RAILING END TRANSITION
(Guardrail Not Shown For Clarity)

CROSS REFERENCE:
For location of Section A-A, View B-B
and View C-C, see Sheet 1.

NOTES:

1. Begin placing Railing Bars 5T and 5X on Approach Slab at the railing end and proceed toward Begin or End Bridge to avoid conflict with guardrail bolt holes. If required, adjustments to the bar spacing for Bars 5T and 5X shall be made immediately adjacent to Begin or End Bridge. Cut, shift and rotate Bars 5T and 5X as required to maintain cover in Railing End Transition.
2. Omit Railing End Transition and Guardrail if Concrete Traffic Railing is used beyond the Approach Slab or Retaining Wall. See Structures Plans, Plan and Elevation Sheet and Roadway Plans. If Taper and Railing End Transition is omitted, extend Typical Section to end of the Approach Slab or limiting station on Retaining Wall, and space Bars 5T and 5X at 1'-0" (Typ.)

1/10/2025 1:06:04 PM

LAST REVISION 11/01/25	REVISION	DESCRIPTION:	 FY 2026-27 STANDARD PLANS	TRAFFIC RAILING - (42" VERTICAL SHAPE)	INDEX 521-422	SHEET 2 of 3
---------------------------	----------	--------------	---	--	------------------	-----------------

CONVENTIONAL REINFORCING STEEL BENDING DIAGRAMS

BILL OF REINFORCING STEEL		
MARK	SIZE	LENGTH
S	5	As Req'd.
T	5	10'-8"
X	5	6'-9"

ROADWAY CROSS-SLOPE	ØA	
	LOW GUTTER	HIGH GUTTER
0% to 2%	90°	90°
2% to 6%	87°	83°
6% to 10%	84°	96°

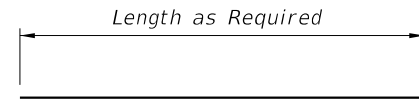

BAR 5S

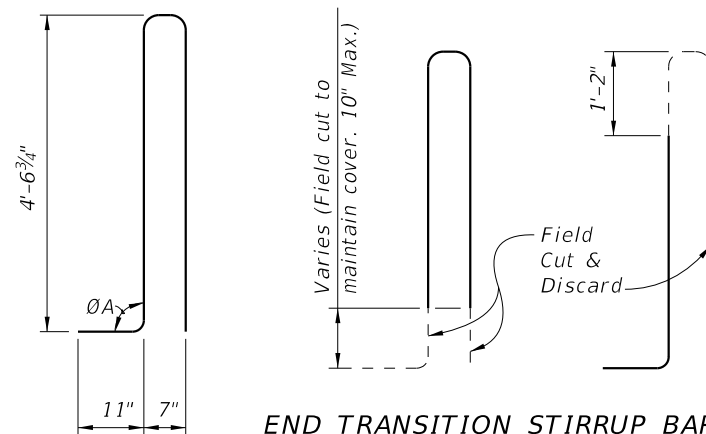

STIRRUP BAR 5T

END TRANSITION STIRRUP BARS 5T
To Be Field Cut (7 of each required per Railing End Transition)

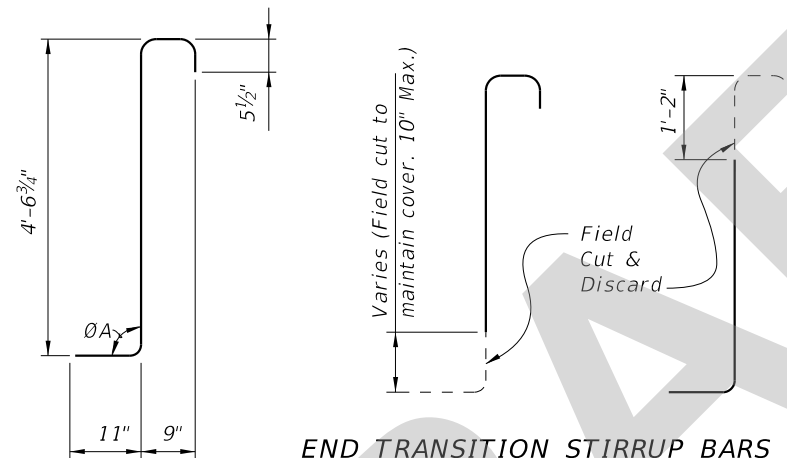

STIRRUP BAR 5X

END TRANSITION STIRRUP BARS 5X
To Be Field Cut (7 of each required per Railing End Transition)

REINFORCING STEEL NOTES:

- All bar dimensions in the bending diagrams are out to out.
- The 4'-6 3/4" vertical dimension shown for Bars 5T and 5X is based on a bridge deck with a 6" thick x 6' wide raised sidewalk at low side of deck, 2% deck cross slope and a counter 2% raised sidewalk cross slope. If the raised sidewalk thickness, width or cross slope vary from the above amounts, adjust this dimension accordingly to achieve a 6" minimum embedment into the bridge deck. See Structures Plans, Superstructure and Approach Slab Sheets.
- The reinforcement for the railing on a retaining wall shall be the same as detailed above with ØA = 90°.
- All reinforcing steel at the open joints shall have a 2" minimum cover.
- Bars 5S may be continuous or spliced at the construction joints. Bar splices for Bars 5S shall be a minimum of 2'-2".
- The Contractor may utilize Welded Wire Reinforcement (WWR) when approved by the Engineer. WWR must consist of Deformed wire meeting the requirements of Specification Section 931.

INTERMEDIATE JOINT SEAL NOTES:

- At Intermediate Open Joints, seal the lower 6" portion of the open joint with Pre-cured Silicone Sealant in accordance with Specification Section 932.
- Apply sealant prior to any Class V finish coating and remove all curing compound and loose material from the surface prior to application of bonding agent.
- The cost of the Pre-cured Silicone Sealant shall be included in the Contract Unit Price for the Traffic Railing.
- As an alternative option, a mortar plug may be used to seal the joint as shown in the mortar plug detail and in accordance with Specification Section 400.

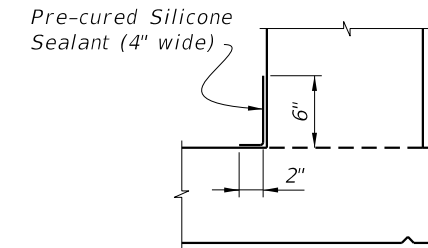

OPTION I

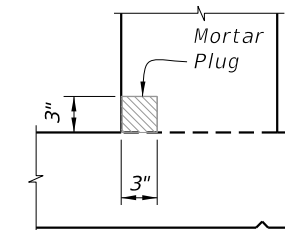

OPTION II
(Alternative Mortar Plug at Open Joint)

DETAIL "A"

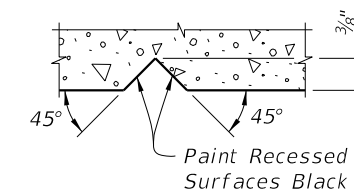

SECTION THRU RECESSED "V" GROOVE TO FORM INSCRIBED LETTERS AND FIGURES

ESTIMATED TRAFFIC RAILING QUANTITIES		
ITEM	UNIT	QUANTITY
Concrete	CY/LF	0.145
Reinforcing Steel	LB/LF	30.68

(The above quantities are based on a 6" thick x 6' wide raised sidewalk at low side of deck, 2% deck cross slope and counter 2% sidewalk cross slope)

5/23/2025 12:23:20 PM