

Origination Form
Proposed Revisions to a Standard Plans Index

Originator:	Turley, Joshua	Index Number:	400-091
Date:	5/15/2025	Sheet Number(s):	Sheet 2
E-mail:	Joshua.Turley@dot.state.fl.us	Index Title:	APPROACH SLABS (30 FT.) (RIGID PAVEMENT APPROACHES)

Summary of the changes:

Sheet 2: Converted starred notes to numerical notes. Adjusted the coping embed requirements for the top of the retaining wall in SECTION THRU APPROACH SLAB AND RETAINING WALL.

Commentary/Background:

Contractors had trouble meeting top-of-wall elevations for MSE walls due to settlement issues. When predicted settlement didn't occur, walls were too high and required sawcutting. To address this, minimum thickness and embedment requirements for Expanded Polystyrene were relaxed, allowing better control over final wall elevations.

Other Affected Documents/Offices	Person Contacted	Affected (Yes/No)
Other Standard Plans		No
FDOT Design Manual		No
Standard Specifications		No
Basis of Estimates Manual		No
Approved Product List		No
Construction Office		No
Maintenance Office		No

Implementation

["FY-Standard Plans (Next Release)"]

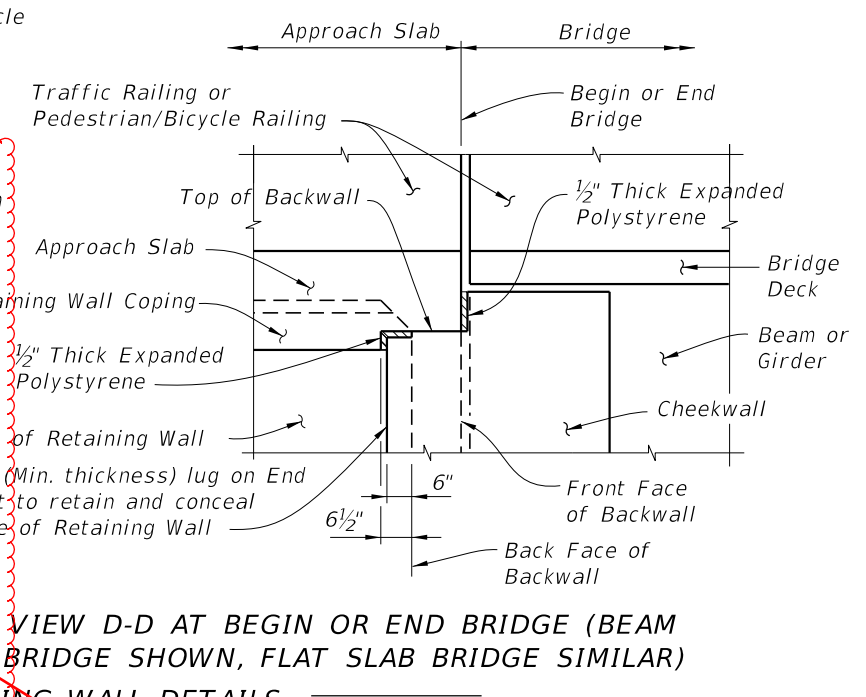
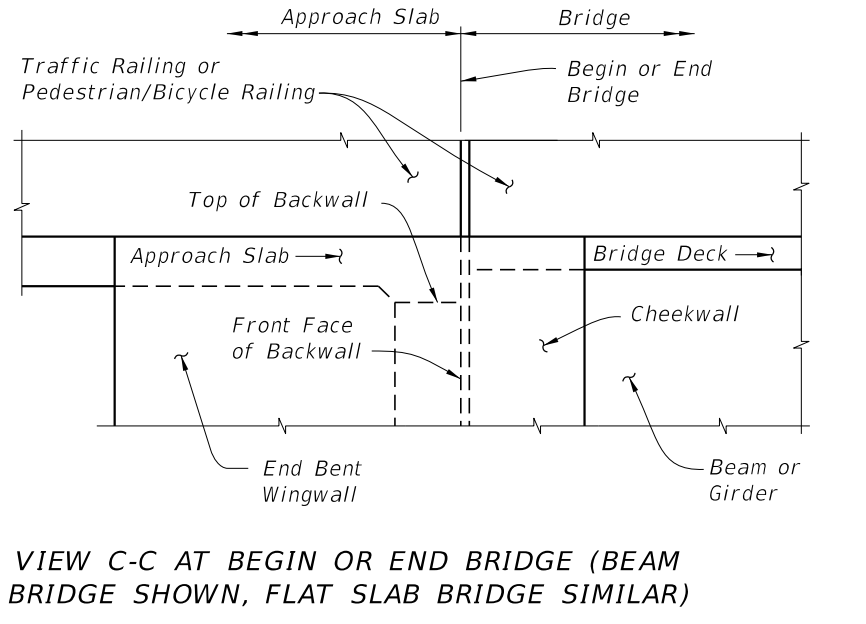
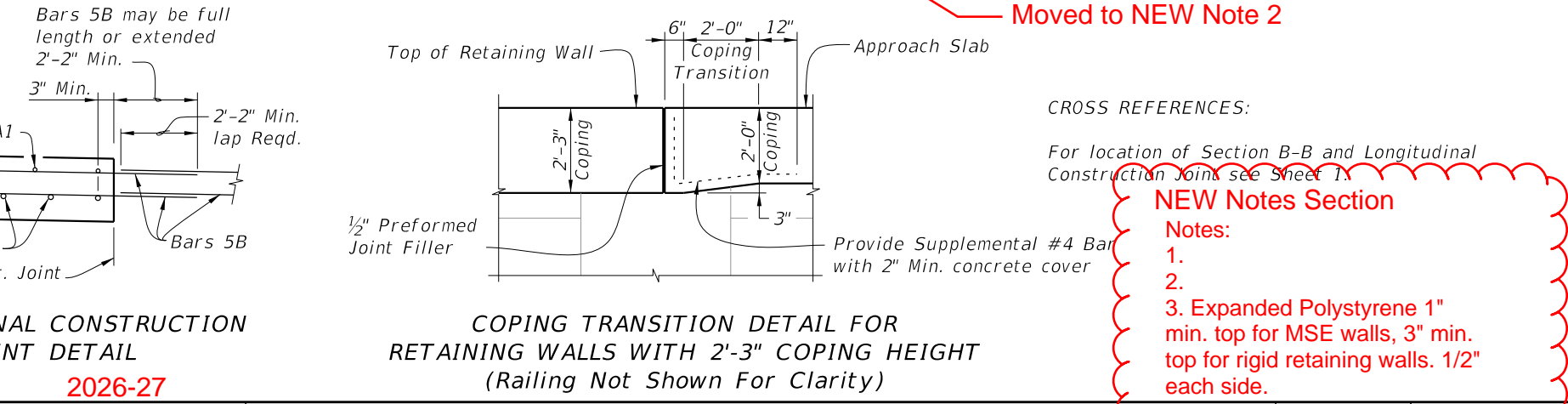
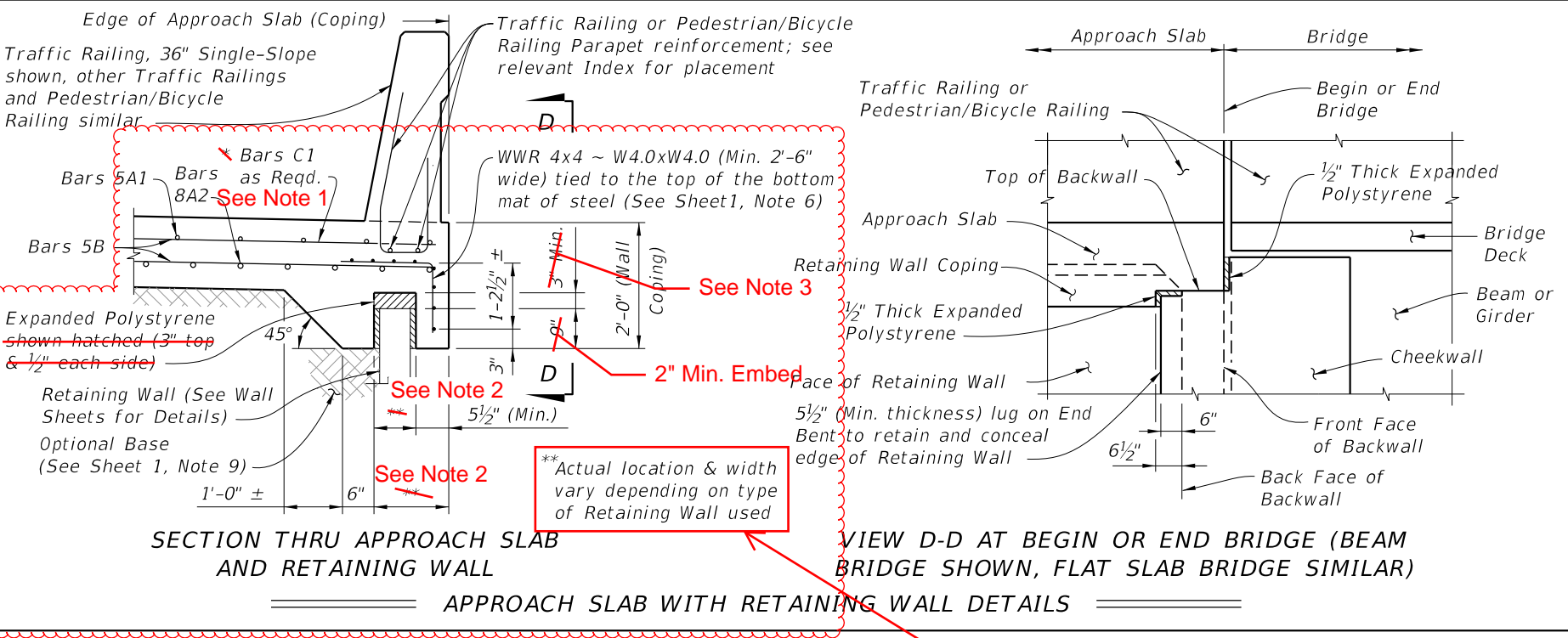
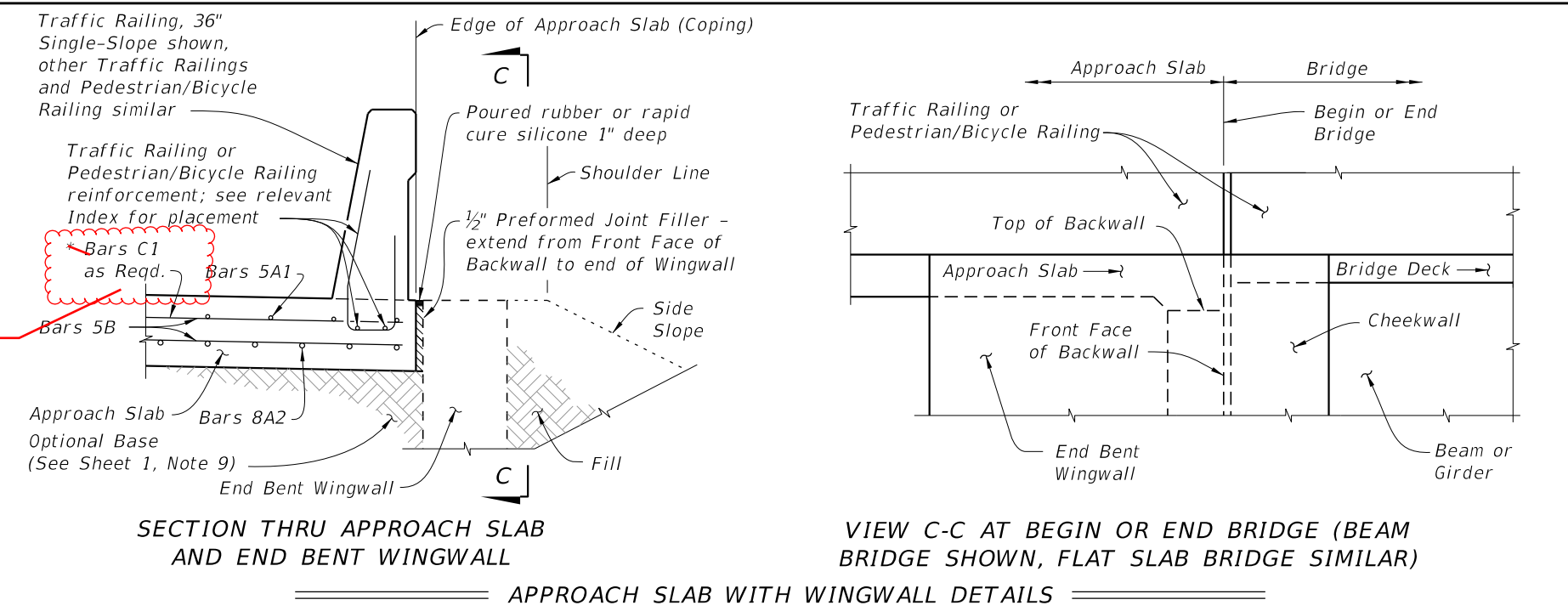
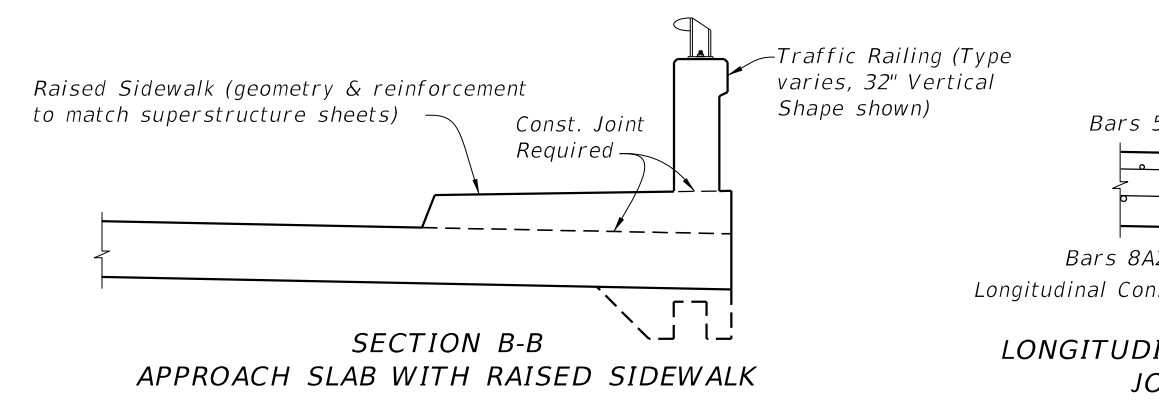
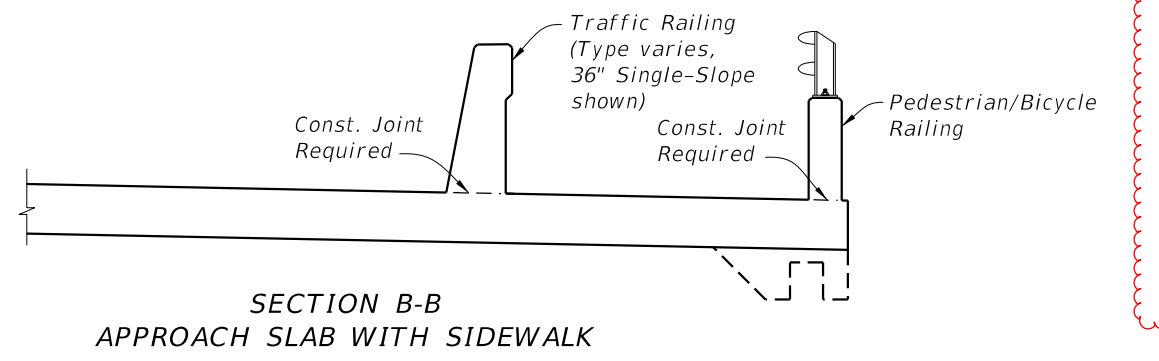
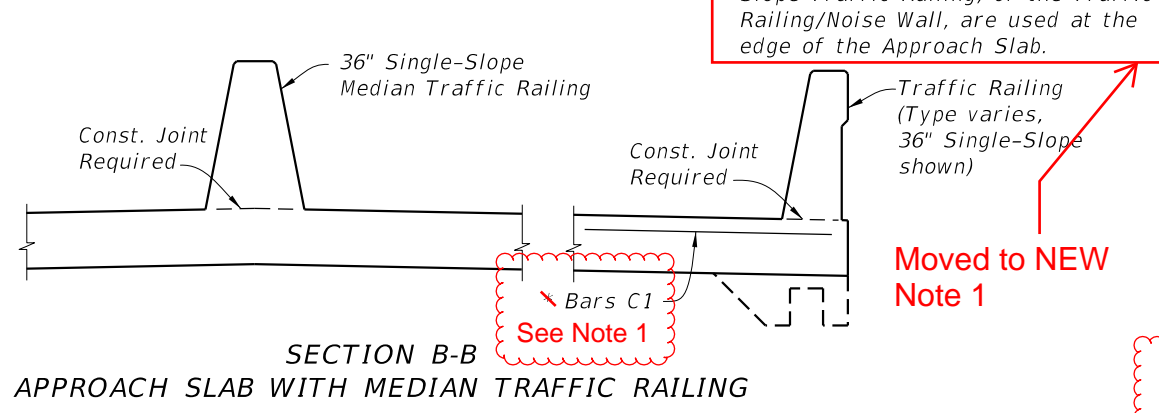
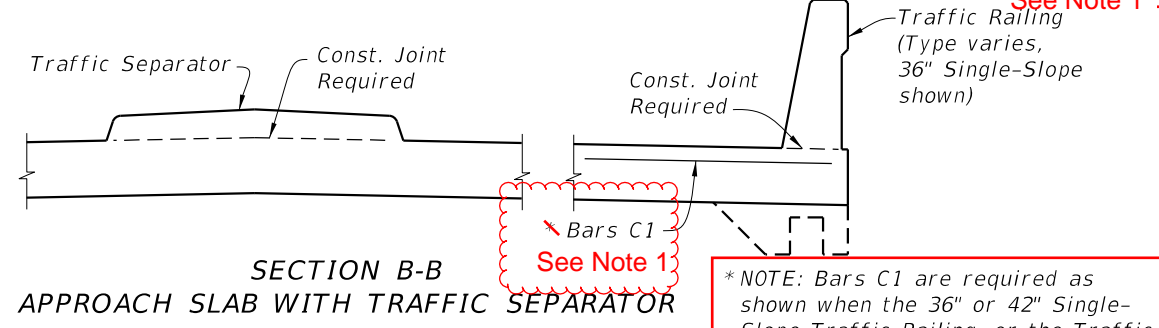
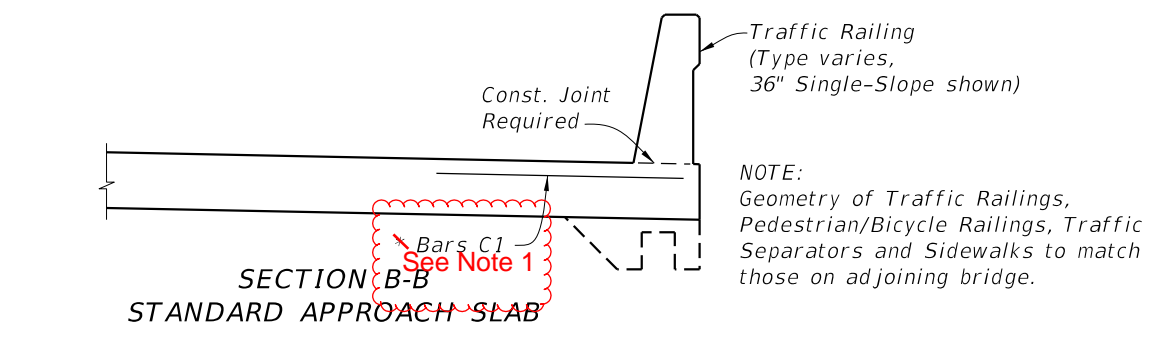

NOTE:
Geometry of Traffic Railings,
Pedestrian/Bicycle Railings, Traffic
Separators and Sidewalks to match
those on adjoining bridge.

*NOTE: Bars C1 are required as
shown when the 36" or 42" Single-
Slope Traffic Railing, or the Traffic
Railing/Noise Wall, are used at the
edge of the Approach Slab.

**Actual location & width
vary depending on type
of Retaining Wall used

Moved to NEW Note 2

CROSS REFERENCES:

For location of Section B-B and Longitudinal
Construction Joint see Sheet 1.

NEW Notes Section

- Notes:
- 1.
 - 2.
 3. Expanded Polystyrene 1" min. top for MSE walls, 3" min. top for rigid retaining walls. 1/2" each side.

10/17/2024 8:06:14 AM

LAST REVISION 11/01/17 11/01/25	DESCRIPTION:	FDOT	FY 2025-26 STANDARD PLANS	2026-27	APPROACH SLABS (30 FT.) (RIGID PAVEMENT APPROACHES)	INDEX 400-091	SHEET 2 of 2
---------------------------------------	--------------	------	------------------------------	---------	--	------------------	-----------------

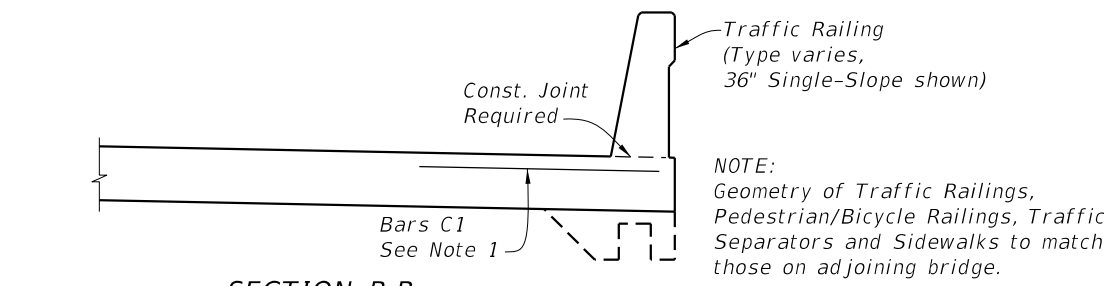

**SECTION B-B
STANDARD APPROACH SLAB**

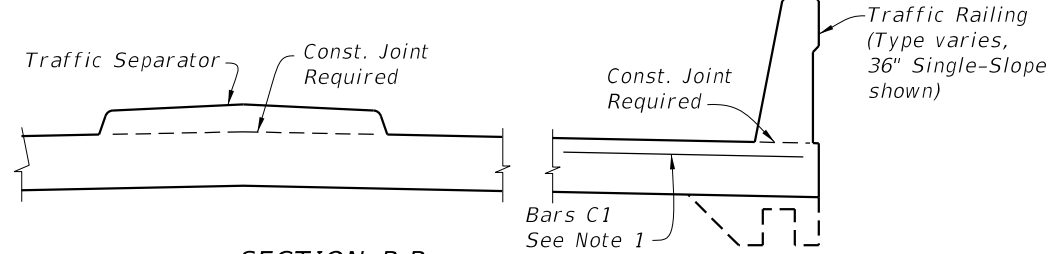

**SECTION B-B
APPROACH SLAB WITH TRAFFIC SEPARATOR**

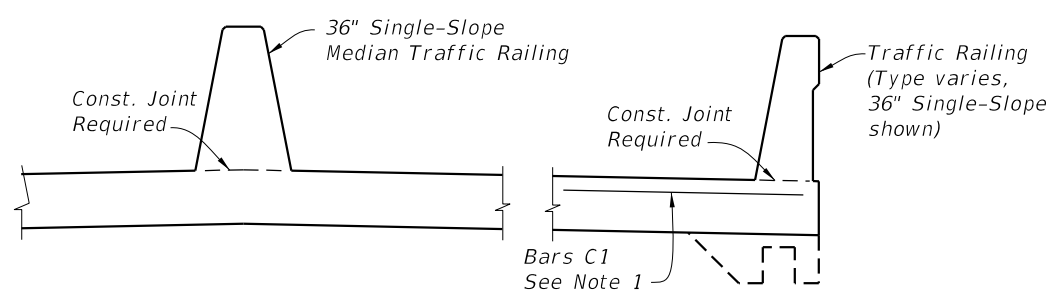

**SECTION B-B
APPROACH SLAB WITH MEDIAN TRAFFIC RAILING**

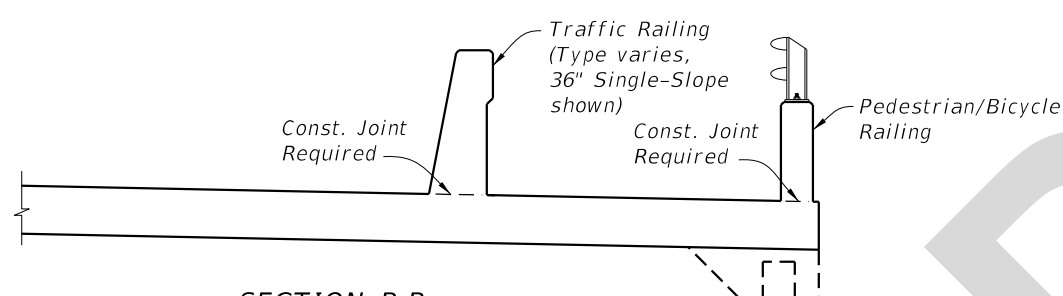

**SECTION B-B
APPROACH SLAB WITH SIDEWALK**

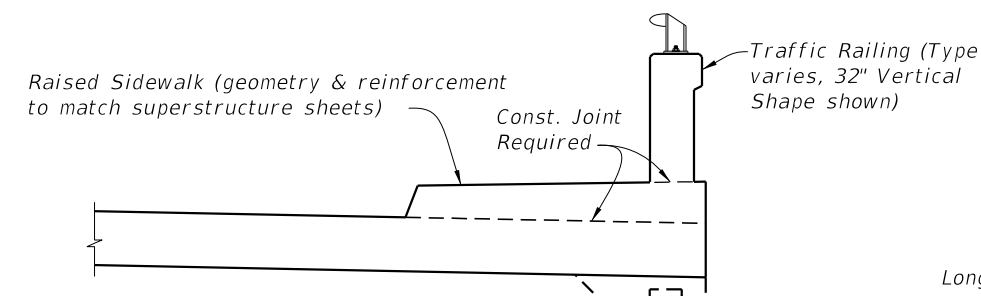

**SECTION B-B
APPROACH SLAB WITH RAISED SIDEWALK**

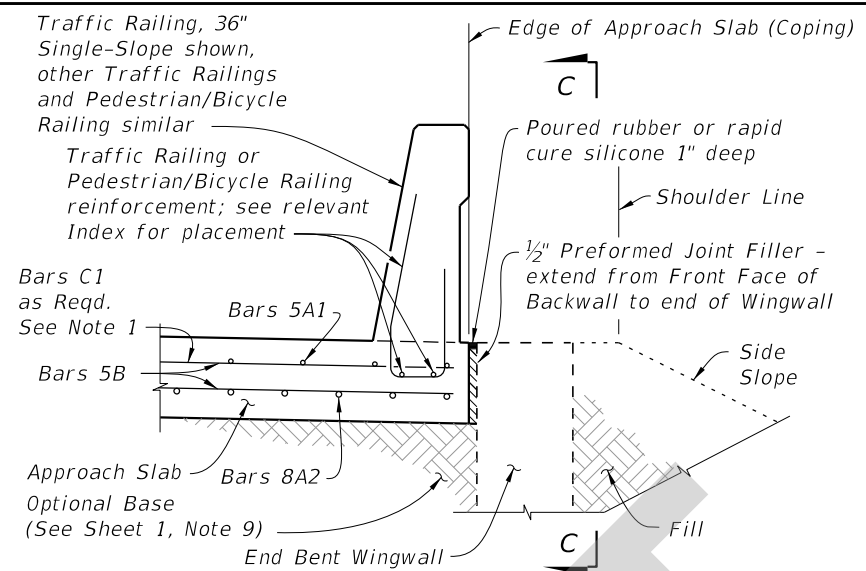

**SECTION THRU APPROACH SLAB
AND END BENT WINGWALL**

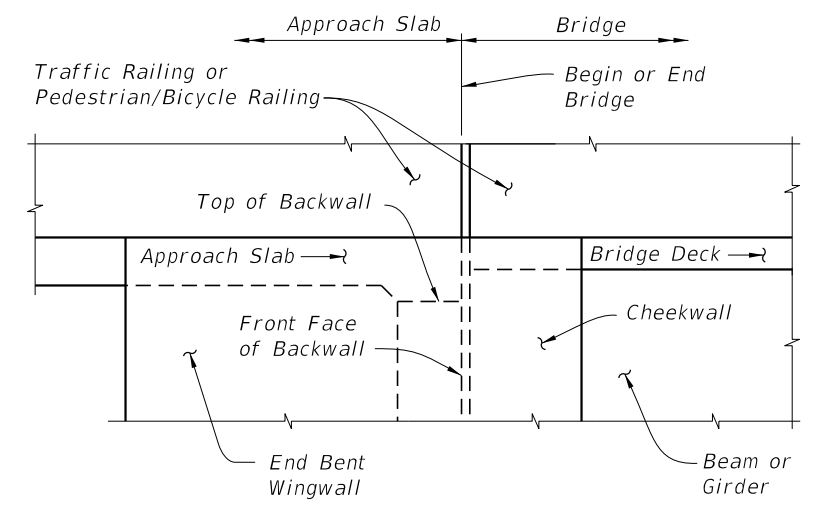

VIEW C-C AT BEGIN OR END BRIDGE (BEAM BRIDGE SHOWN, FLAT SLAB BRIDGE SIMILAR)

APPROACH SLAB WITH WINGWALL DETAILS

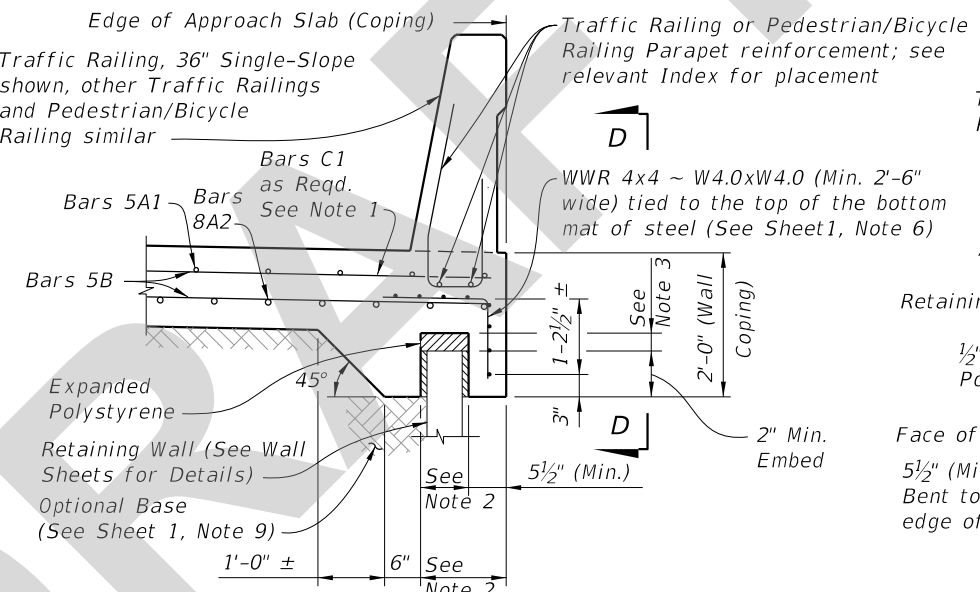

**SECTION THRU APPROACH SLAB
AND RETAINING WALL**

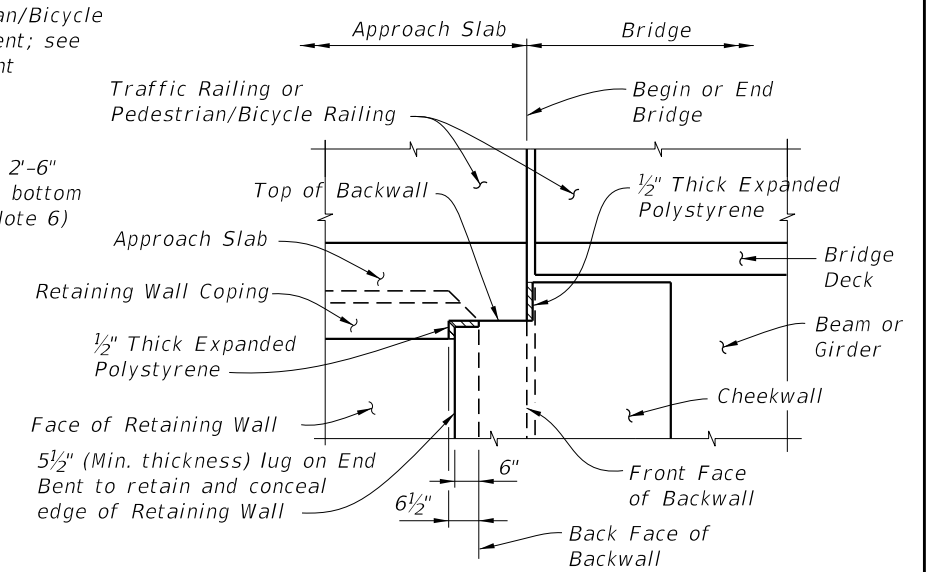

VIEW D-D AT BEGIN OR END BRIDGE (BEAM BRIDGE SHOWN, FLAT SLAB BRIDGE SIMILAR)

APPROACH SLAB WITH RETAINING WALL DETAILS

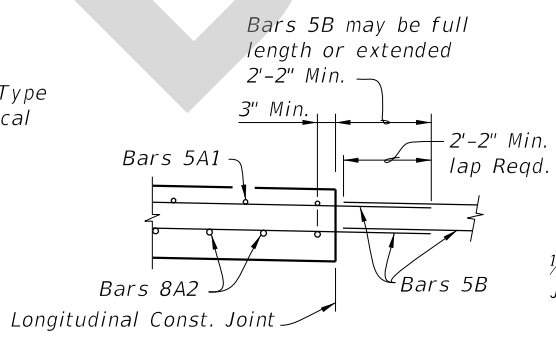

**LONGITUDINAL CONSTRUCTION
JOINT DETAIL**

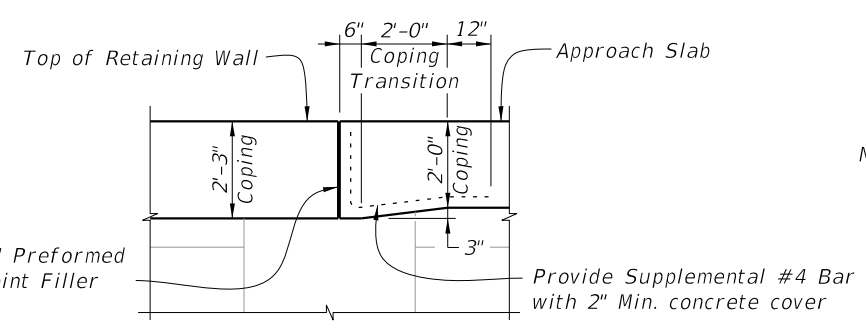

**COPING TRANSITION DETAIL FOR
RETAINING WALLS WITH 2'-3\"/>**

CROSS REFERENCES:

For location of Section B-B and Longitudinal Construction Joint see Sheet 1.

NOTES:

1. Bars C1 are required as shown when the 36" or 42" Single-Slope Traffic Railing, or the Traffic Railing/Noise Wall, are used at the edge of the Approach Slab.
2. Actual location & width vary depending on type of Retaining Wall used.
3. Expanded Polystyrene 1" min. top for MSE walls, 3" min. top for rigid retaining walls. 1/2" each side.

12/19/19 PM 5/23/2025

LAST REVISION 11/01/25	REVISION	DESCRIPTION:		FY 2026-27 STANDARD PLANS	APPROACH SLABS (30 FT.) (RIGID PAVEMENT APPROACHES)	INDEX 400-091	SHEET 2 of 2
---------------------------	----------	--------------	---	------------------------------	--	------------------	-----------------