

# Origination Form

## Proposed Revisions to a Standard Plans Index

<b>Originator:</b>	Turley, Joshua	<b>Index Number:</b>	700-041
<b>Date:</b>	4/11/2024	<b>Sheet Number(s):</b>	2
<b>E-mail:</b>	Joshua.Turley@dot.state.fl.us	<b>Index Title:</b>	SPAN SIGN STRUCTURE

### Summary of the changes:

Sheet 2: Added labeling to the Anchor bolt nuts in BASE PLATE CONNECTION - ELEVATION

### Commentary/Background:

Labels were added to correspond correctly with upcoming spec change to Spec 649.

Other Affected Documents/Offices	Person Contacted	Affected (Yes/No)
Other Standard Plans		No
FDOT Design Manual		No
Standard Specifications		No
Basis of Estimates Manual		No
Approved Product List		No
Construction Office		No
Maintenance Office		No

### Implementation

["FY-Standard Plans (Next Release)"]

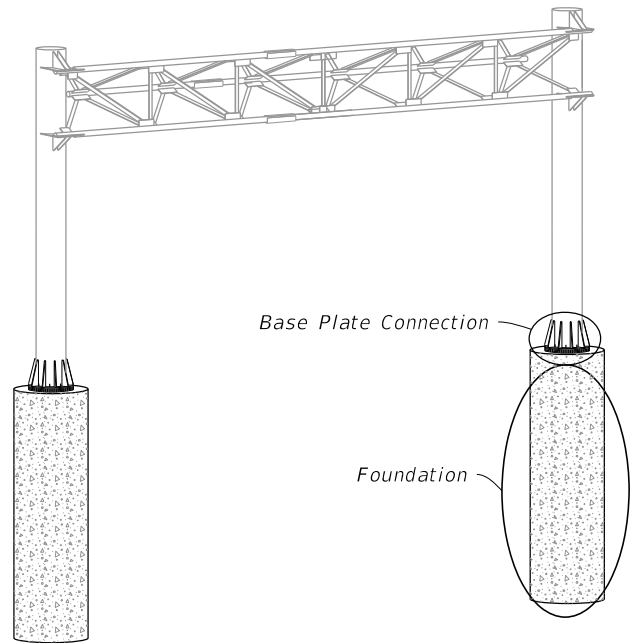

SPAN SIGN ASSEMBLY

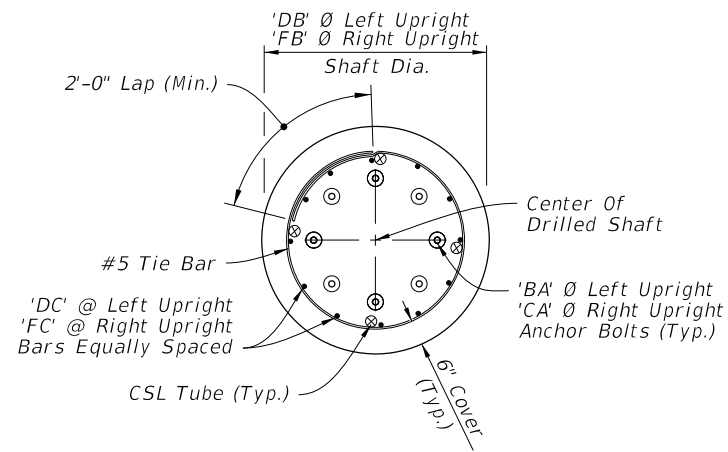

PLAN

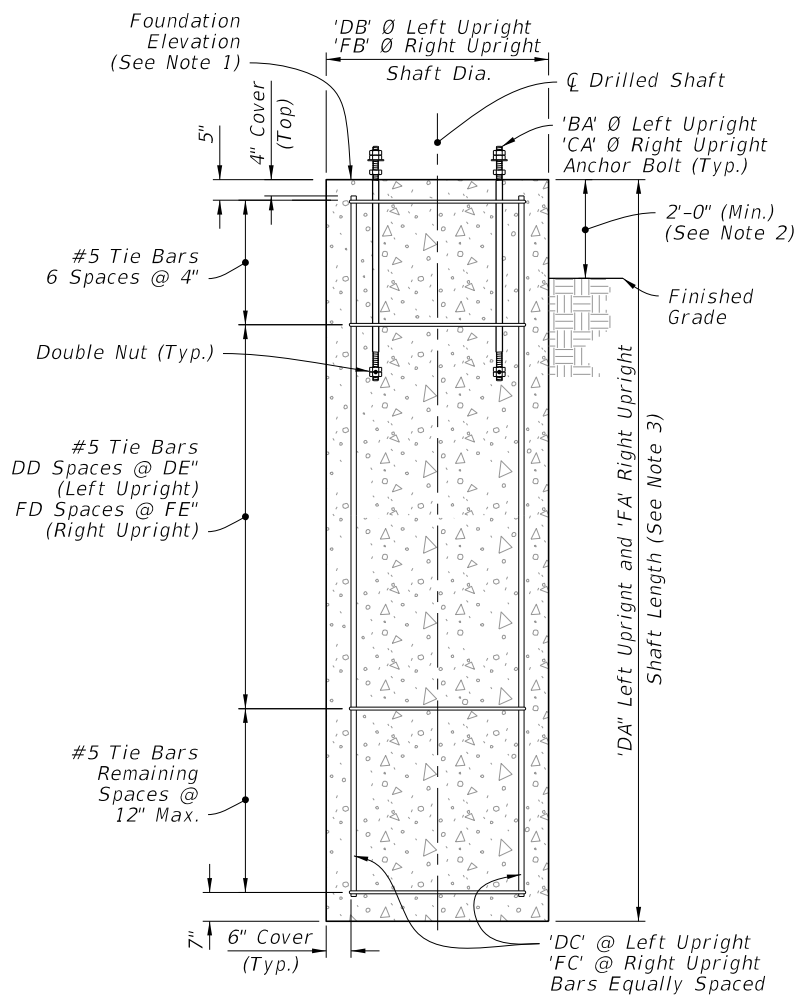

ELEVATION

DRILLED SHAFT

FOUNDATION



DETAIL "A"

DETAIL "B"

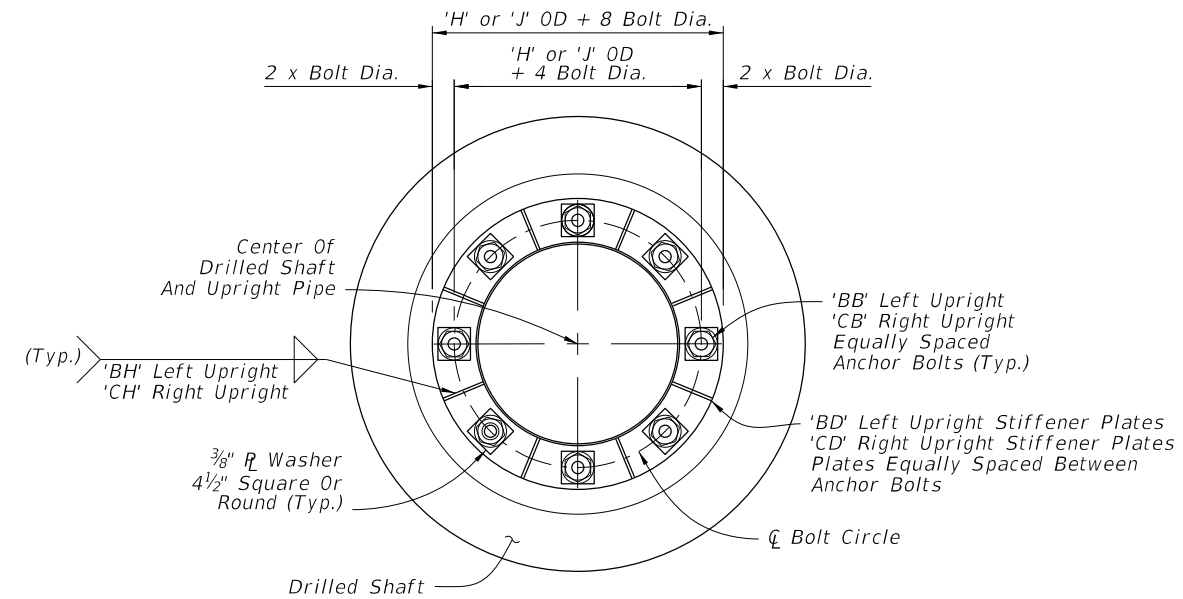

PLAN

ADDED: Retainer Nut  
ADDED: Anchor Nut

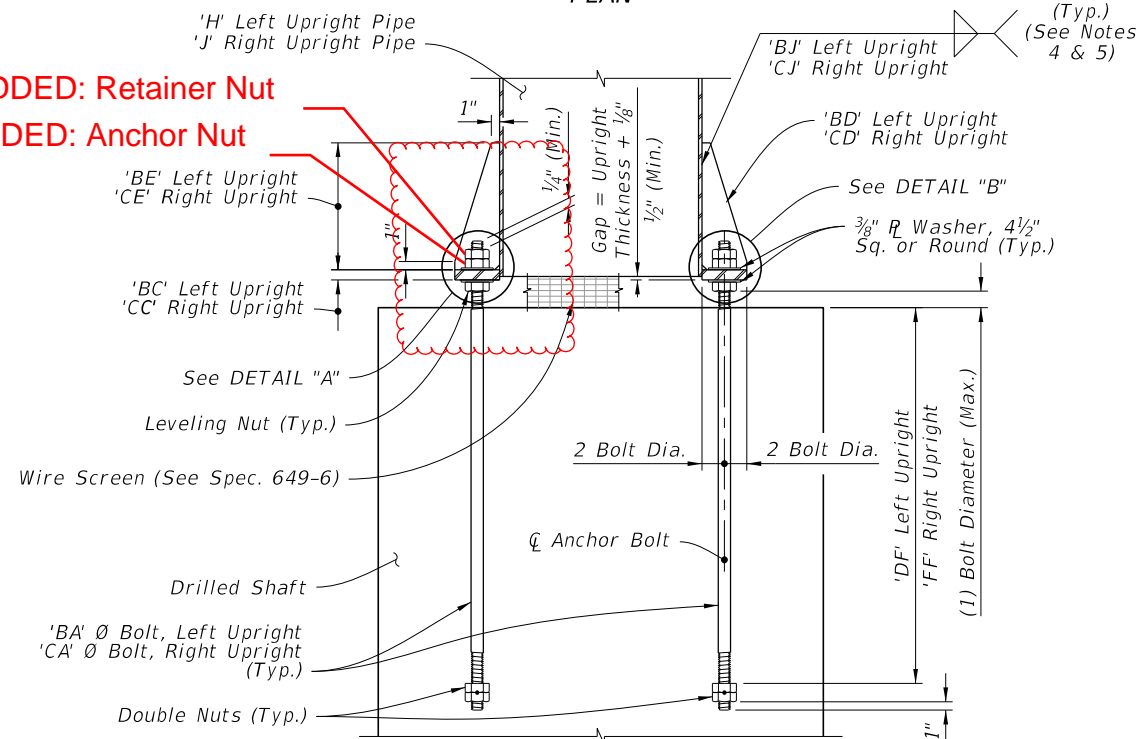

ELEVATION

BASE PLATE CONNECTION

- NOTES:**
1. See Traffic Plans for elevation at top of Foundation.
  2. Install Drilled Shaft with a 2'-0" minimum from top elevation of the drill shaft to the finished grade, unless specified otherwise in the plans.
  3. The shaft length is based on 2'-0" height above finished grade.
  4. Wrap fillet weld around the stiffener termination on the tube wall (Typ).
  5. After galvanizing, provide magnetic particle testing on 100% of upright fillet welds.
  6. Weld plates 'BD' and 'CD' in a star pattern. A star pattern is one in which the plates on opposite and near opposite sides of the pole circle are successively welded in a pattern resembling a star. For an 8 plate circle with plates sequentially numbered 1 to 8, weld the plates in the following order: (1, 5, 7, 3, 8, 4, 6, 2).

10/17/2023 7:23:29 AM

LAST 24 REVISION 11/01/22	DESCRIPTION:	 FY 2024-25 STANDARD PLANS	SPAN SIGN STRUCTURE	INDEX 700-041	SHEET 2 of 5
------------------------------	--------------	----------------------------------	---------------------	------------------	-----------------

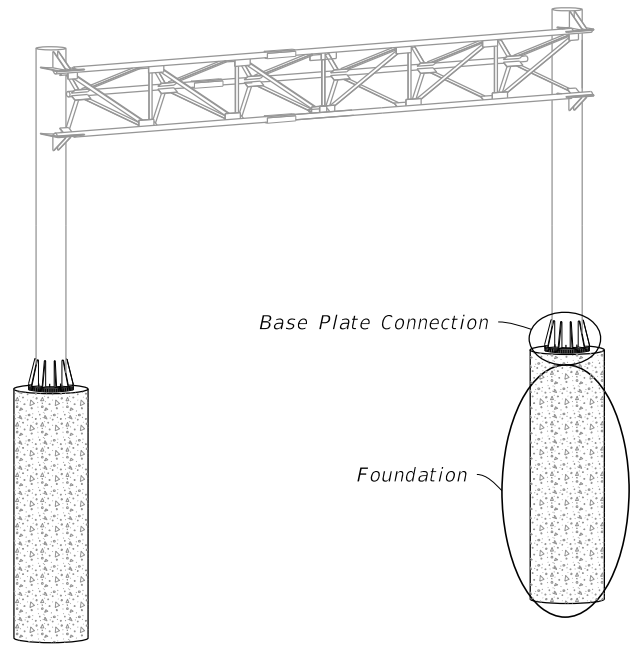

SPAN SIGN ASSEMBLY

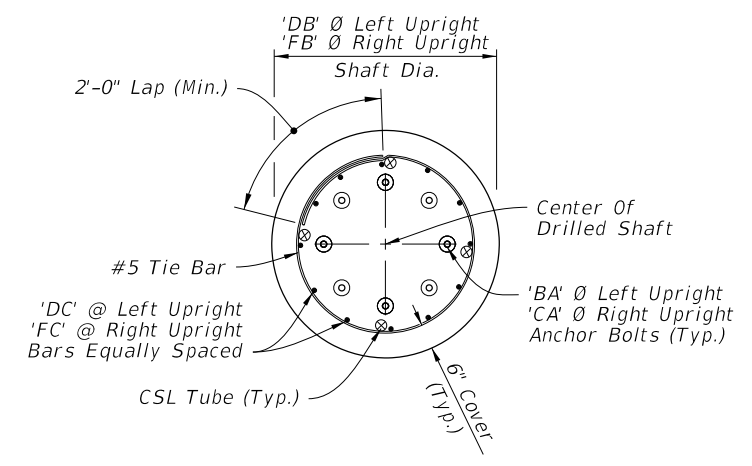

PLAN

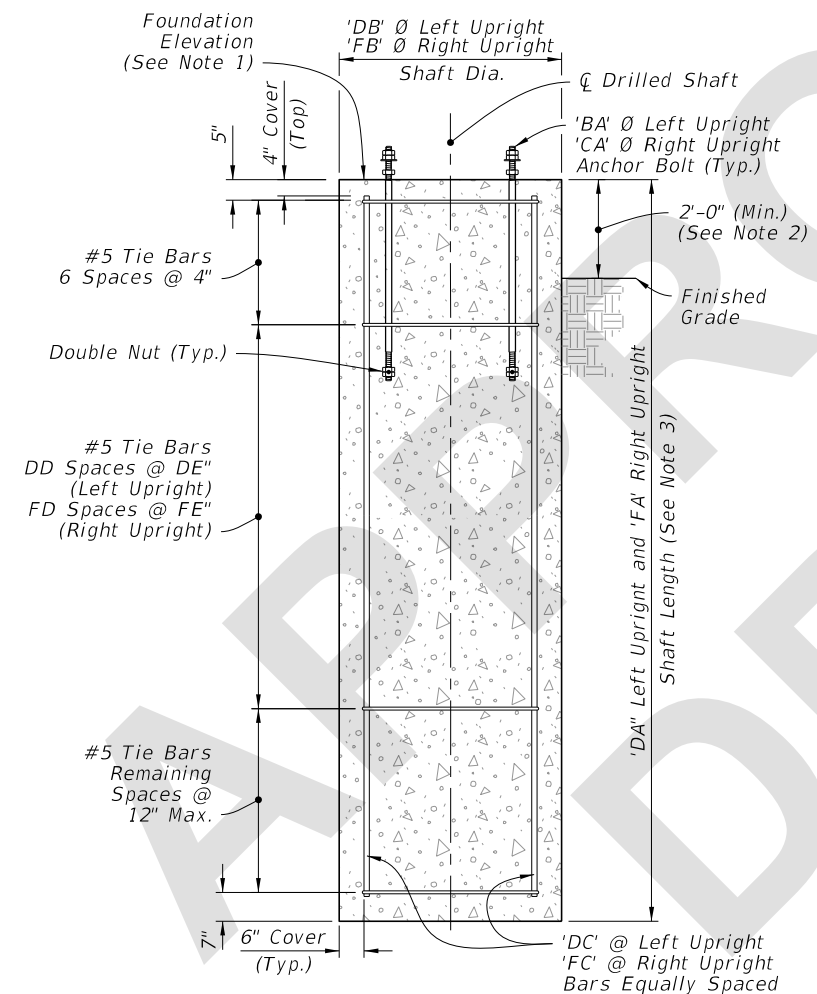

ELEVATION

DRILLED SHAFT

FOUNDATION

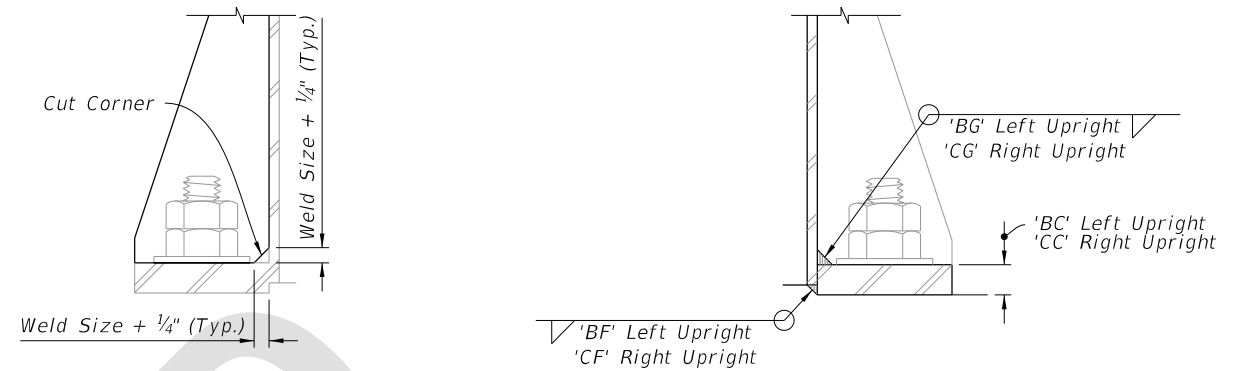

DETAIL "A"

DETAIL "B"

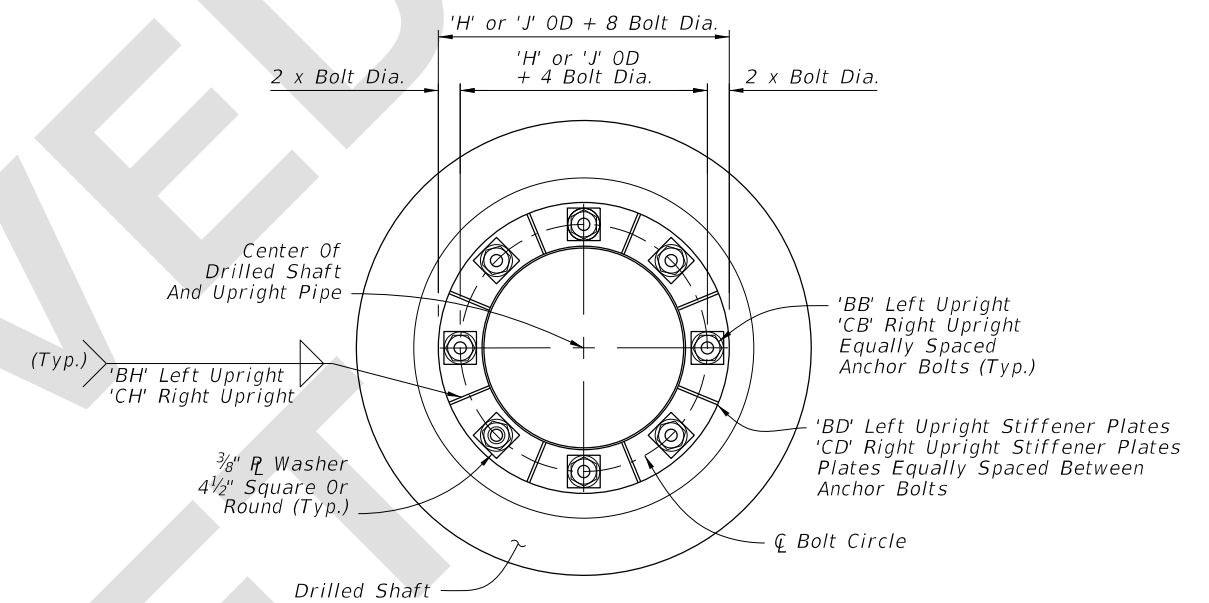

PLAN

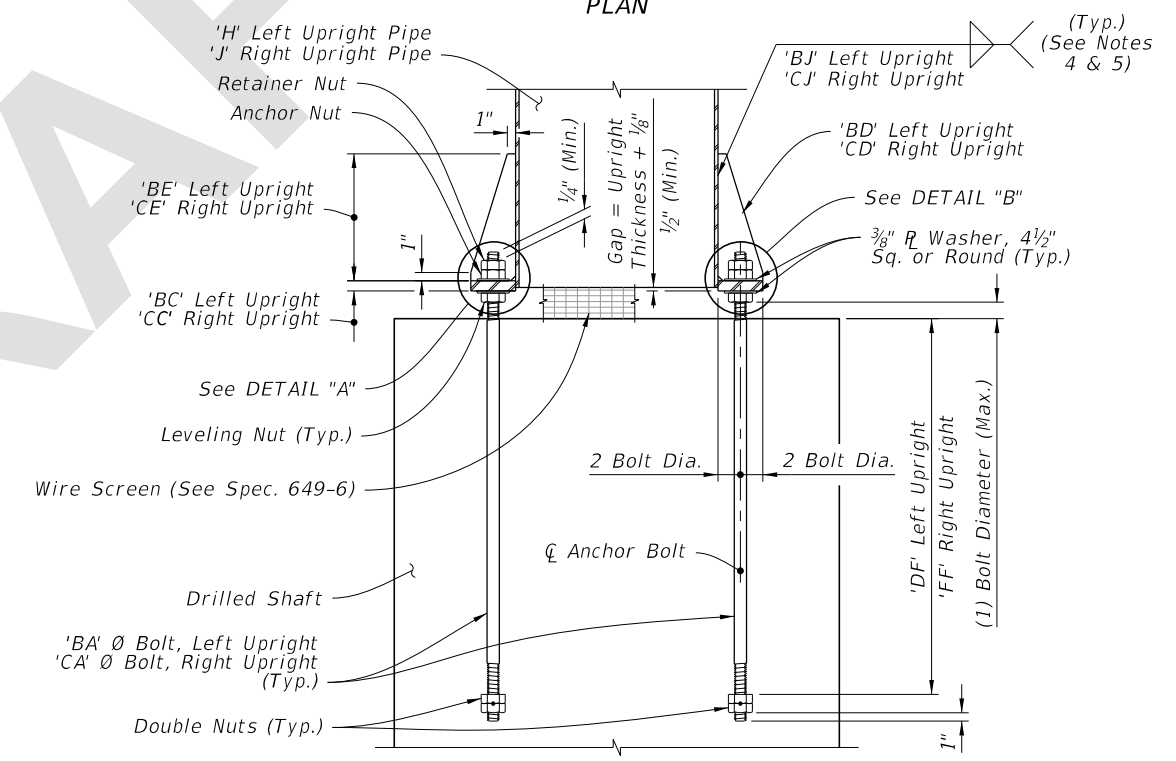

ELEVATION

BASE PLATE CONNECTION

- NOTES:**
1. See Traffic Plans for elevation at top of Foundation.
  2. Install Drilled Shaft with a 2'-0" minimum from top elevation of the drill shaft to the finished grade, unless specified otherwise in the plans.
  3. The shaft length is based on 2'-0" height above finished grade.
  4. Wrap fillet weld around the stiffener termination on the tube wall (Typ).
  5. After galvanizing, provide magnetic particle testing on 100% of upright fillet welds.
  6. Weld plates 'BD' and 'CD' in a star pattern. A star pattern is one in which the plates on opposite and near opposite sides of the pole circle are successively welded in a pattern resembling a star. For an 8 plate circle with plates sequentially numbered 1 to 8, weld the plates in the following order: (1, 5, 7, 3, 8, 4, 6, 2).

5/29/2024 8:58:42 AM

LAST REVISION 11/01/24	DESCRIPTION:		FY 2025-26 STANDARD PLANS	SPAN SIGN STRUCTURE	INDEX	SHEET
					700-041	2 of 5