

Origination Form
Proposed Revisions to a Standard Plans Index

Originator:	Turley, Joshua	Index Number:	700-040
Date:	4/17/2024	Sheet Number(s):	2
E-mail:	Joshua.Turley@dot.state.fl.us	Index Title:	CANTILEVER SIGN STRUCTURE

Summary of the changes:

Sheet 2: Added anchor bolt nut labels in BASE PLATE CONNECTION

Commentary/Background:

There is an associated Spec change being drafted for Section 649 that pertains to process for tightening the anchor bolts. These changes make it so that the language aligns between the Spec and the Standard.

Other Affected Documents/Offices	Person Contacted	Affected (Yes/No)
Other Standard Plans		No
Florida Design Manual		No
Standard Specifications		No
Basis of Estimates Manual		No
Approved Product List		No
Construction Office		No
Maintenance Office		No

Implementation

["FY-Standard Plans (Next Release)"]

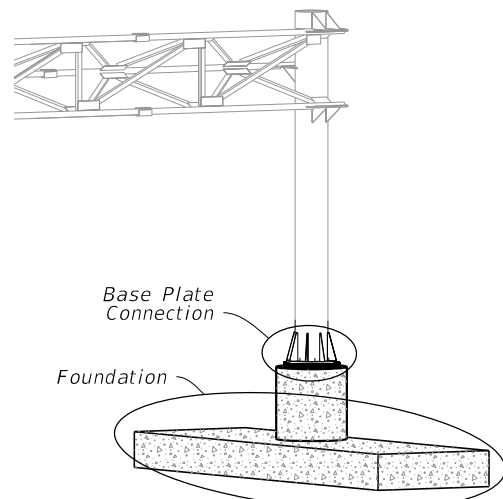

CANTILEVER ASSEMBLY

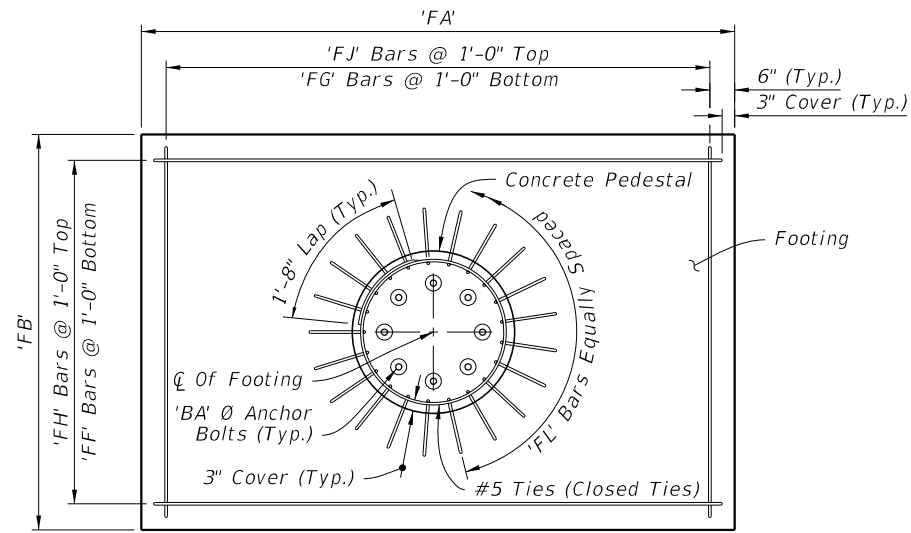

PLAN

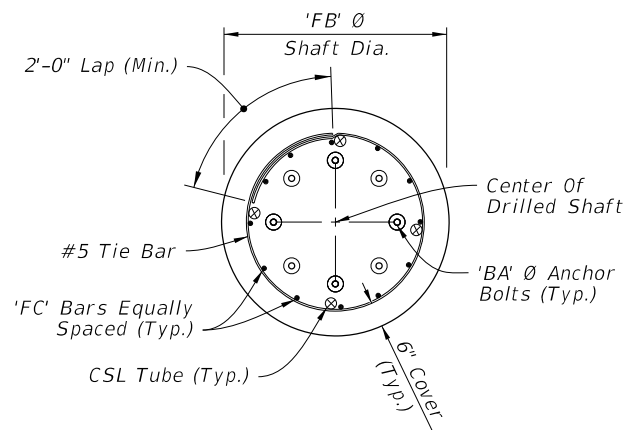

PLAN

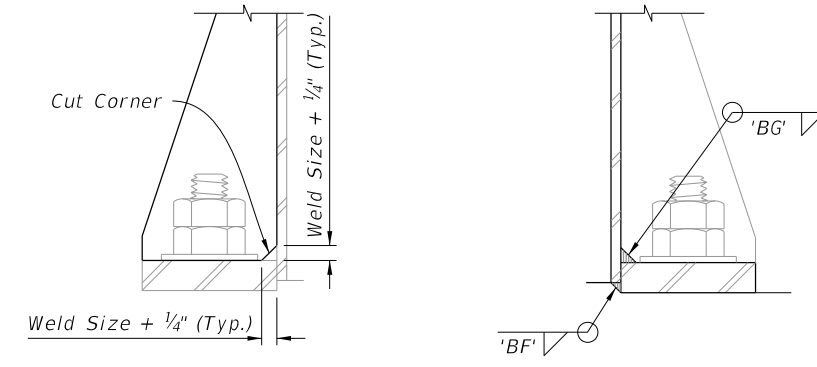

DETAIL 'A'

DETAIL 'B'

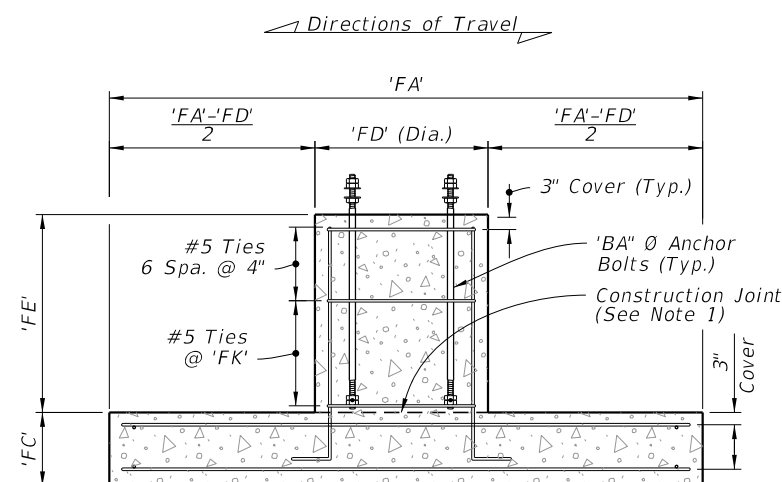

SIDE ELEVATION

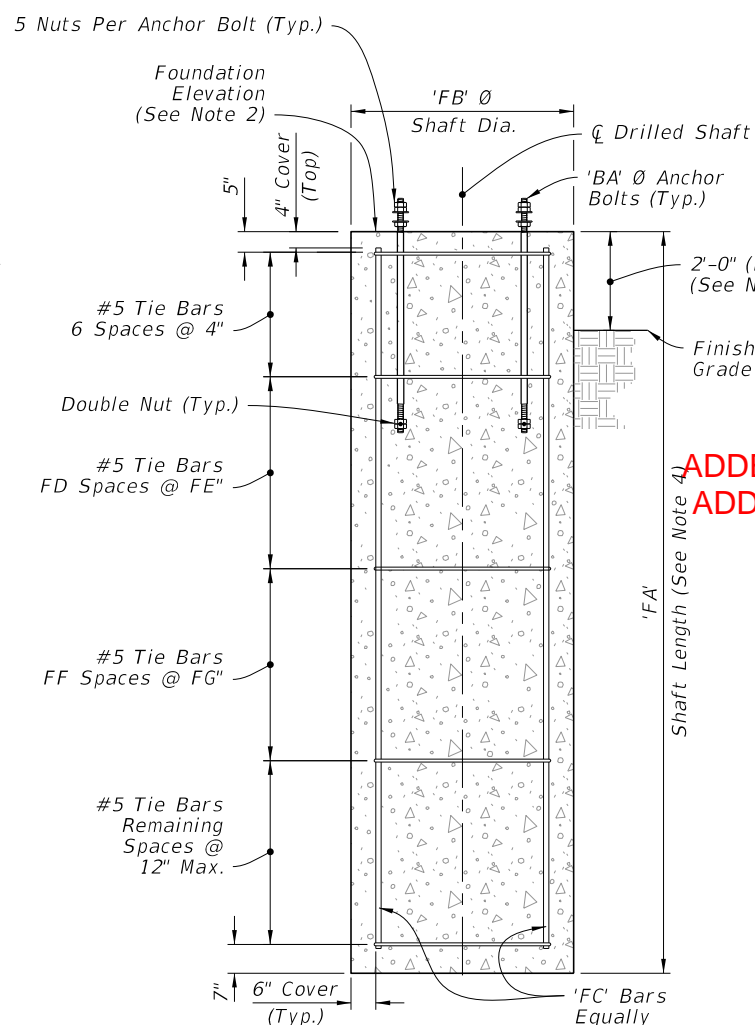

ELEVATION

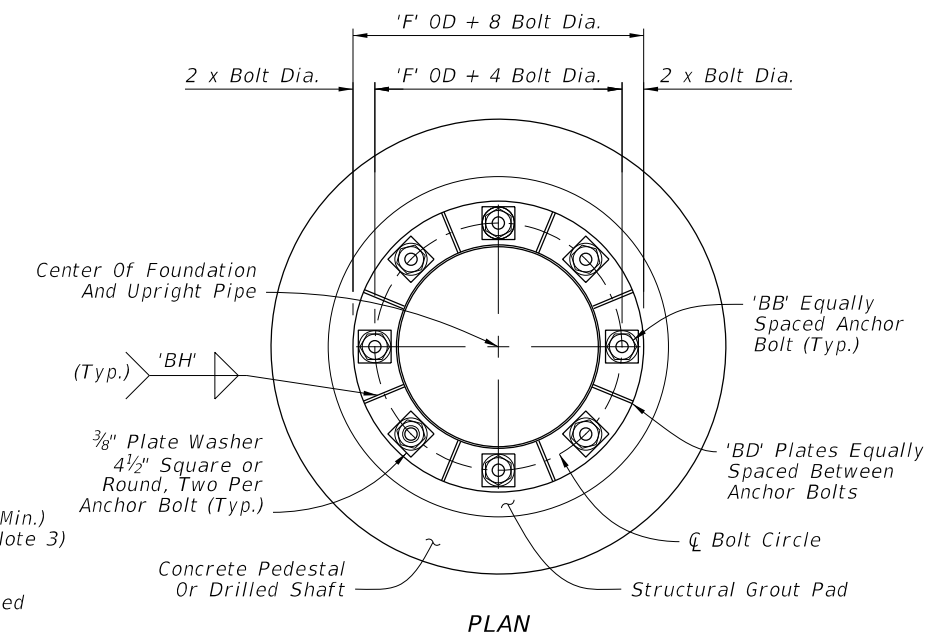

PLAN

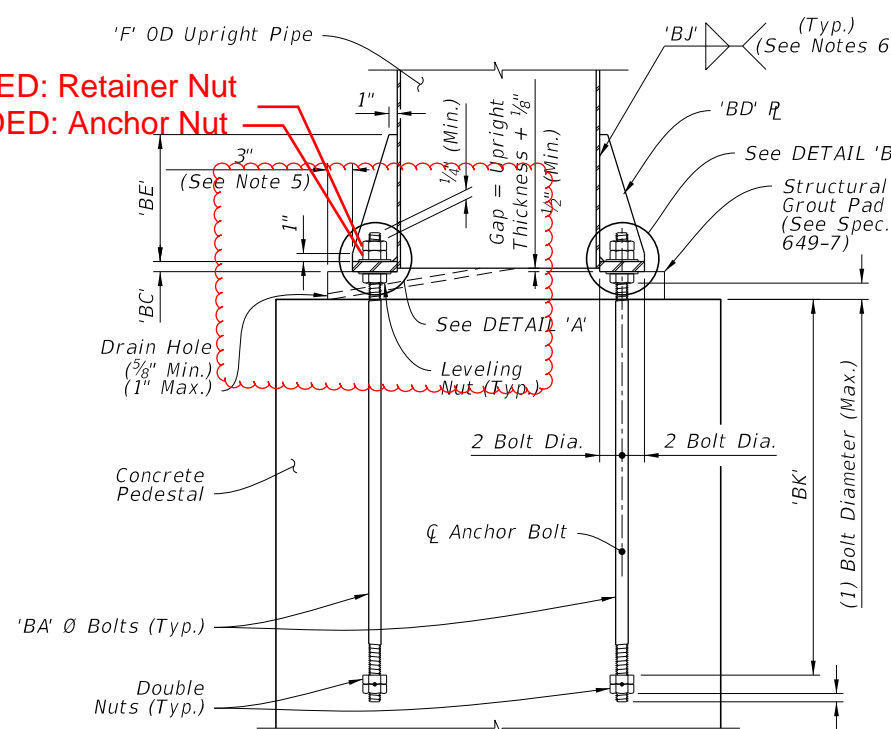

ELEVATION

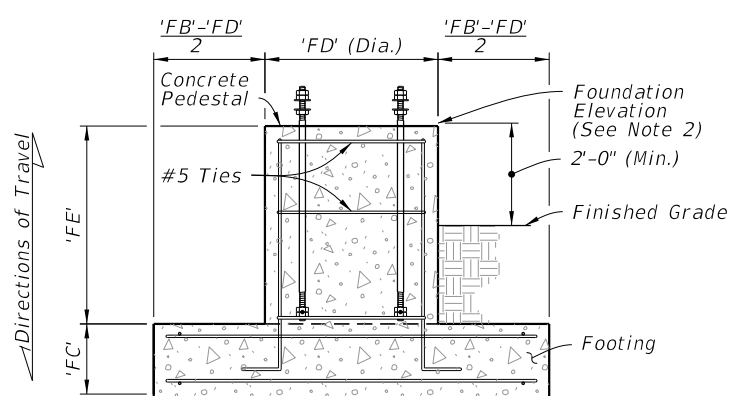

FRONT ELEVATION

FOOTING AND PEDESTAL

DRILLED SHAFT
(Alternate Foundation)

FOUNDATION

BASE PLATE CONNECTION

NOTES:

- Construction joint allowed, roughen surface to 1/4" minimum amplitude prior to pour.
- See Traffic Plans for elevation at top of Foundation.
- Install Drilled Shaft with a 2'-0" minimum from top elevation of the drilled shaft to the finished grade, unless specified otherwise in the plans.
- The shaft length is based on 2'-0" height above finished grade.
- Structural Grout Pad dimension may be modified to be less than 3" where the footprint of the Structural Grout Pad does not provide adequate clearance for accessibility considerations.
- Wrap fillet weld around the stiffener termination on the tube wall.
- Weld plates 'BD' in a star pattern. A star pattern is one in which the plates on opposite and near opposite sides of the pole circle are successively welded in a pattern resembling a star. For an 8 plate circle with plates sequentially numbered 1 to 8, weld the plates in the following order: (1, 5, 7, 3, 8, 4, 6, 2).

10/17/2023 7:22:10 AM

LAST REVISION	DESCRIPTION:
11/01/22	



FY 2024-25
STANDARD PLANS

CANTILEVER SIGN STRUCTURE

INDEX	SHEET
700-040	2 of 5

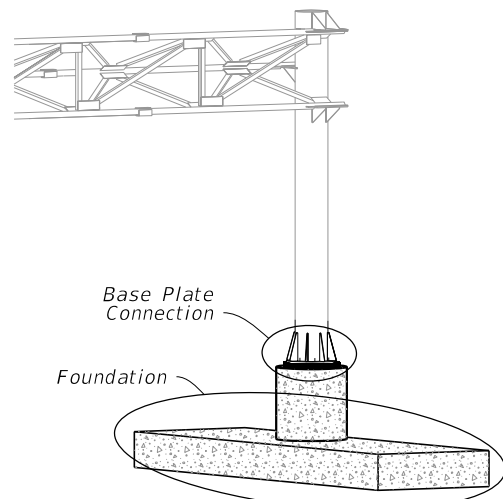

CANTILEVER ASSEMBLY

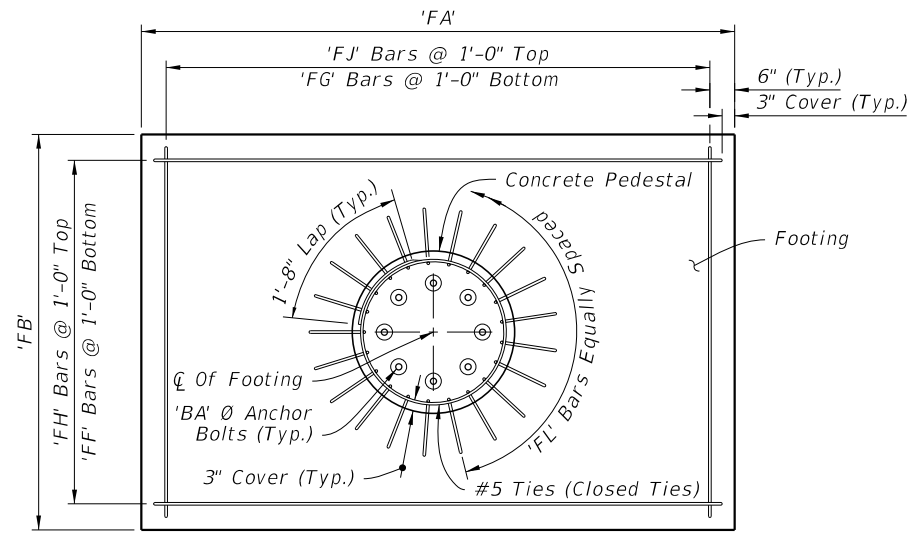

PLAN

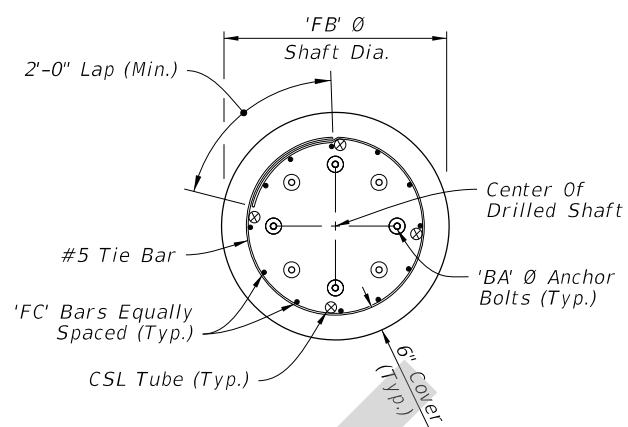

PLAN

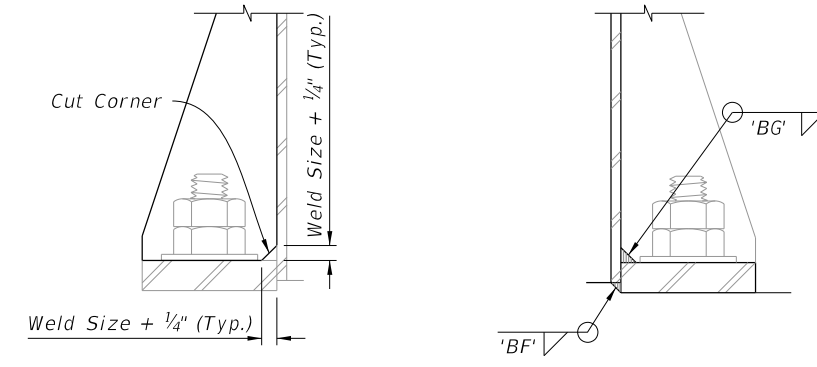

DETAIL 'A'

DETAIL 'B'

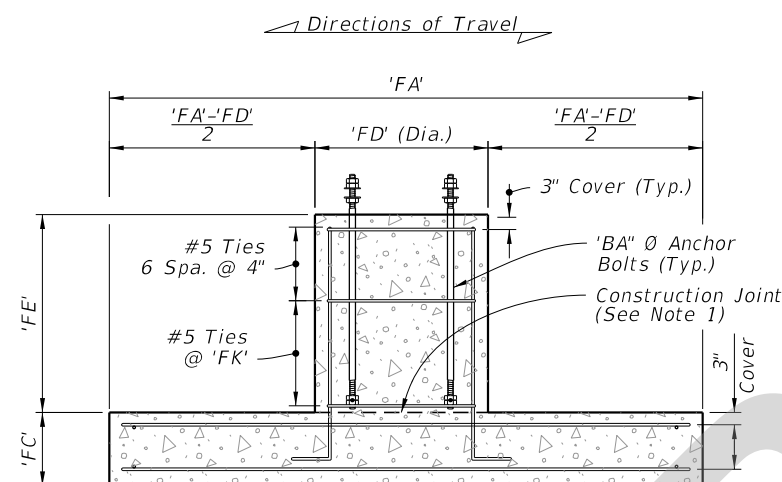

SIDE ELEVATION

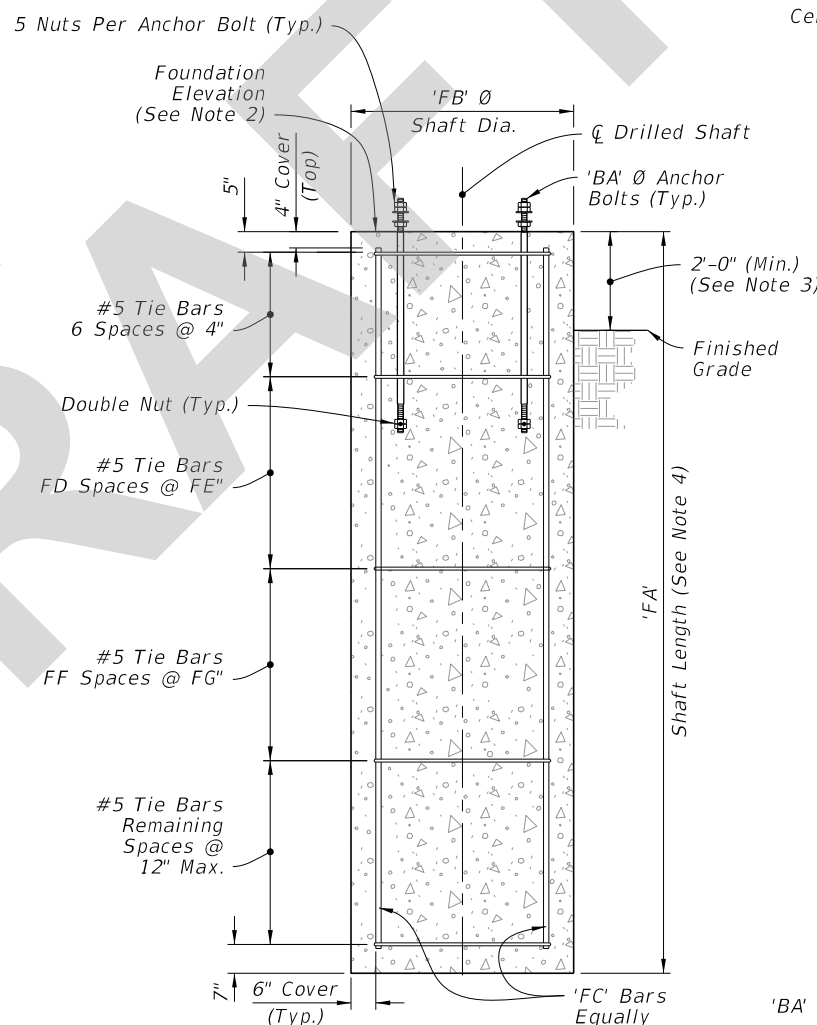

ELEVATION

DRILLED SHAFT
(Alternate Foundation)

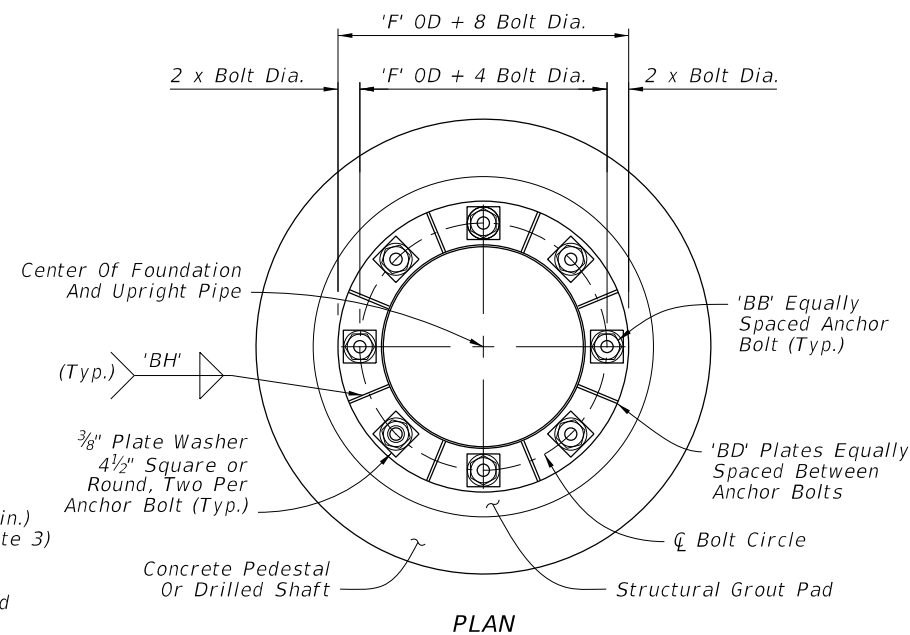

PLAN

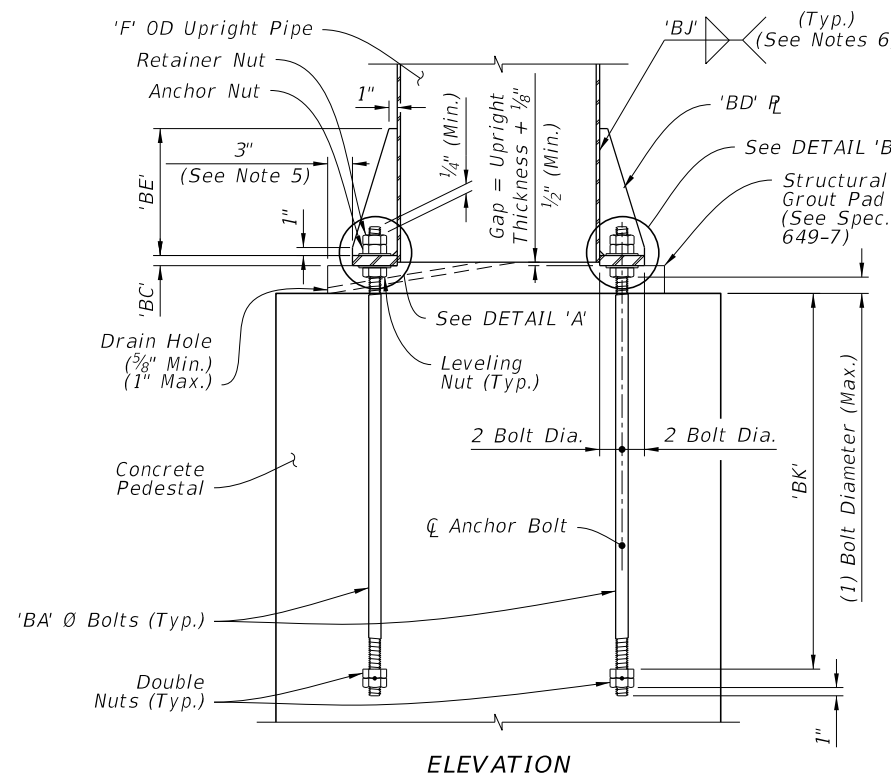

ELEVATION

BASE PLATE CONNECTION

NOTES:

- Construction joint allowed, roughen surface to 1/4" minimum amplitude prior to pour.
- See Traffic Plans for elevation at top of Foundation.
- Install Drilled Shaft with a 2'-0" minimum from top elevation of the drilled shaft to the finished grade, unless specified otherwise in the plans.
- The shaft length is based on 2'-0" height above finished grade.
- Structural Grout Pad dimension may be modified to be less than 3" where the footprint of the Structural Grout Pad does not provide adequate clearance for accessibility considerations.
- Wrap fillet weld around the stiffener termination on the tube wall.
- Weld plates 'BD' in a star pattern. A star pattern is one in which the plates on opposite and near opposite sides of the pole circle are successively welded in a pattern resembling a star. For an 8 plate circle with plates sequentially numbered 1 to 8, weld the plates in the following order: (1, 5, 7, 3, 8, 4, 6, 2).

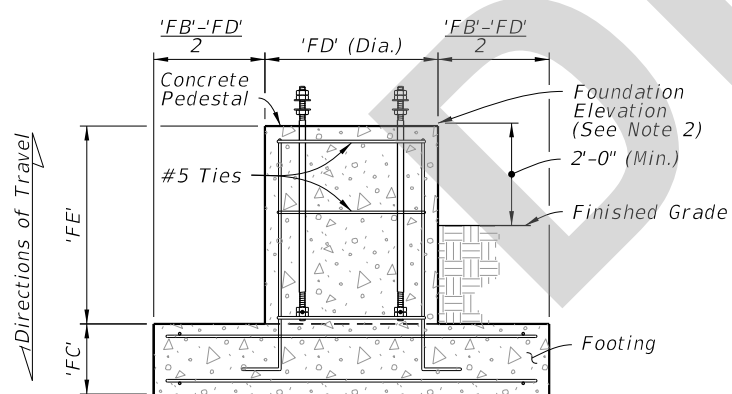

FRONT ELEVATION

FOOTING AND PEDESTAL

FOUNDATION

5/29/2024 8:57:46 AM

LAST REVISION 11/01/24	DESCRIPTION:		FY 2025-26 STANDARD PLANS	CANTILEVER SIGN STRUCTURE	INDEX 700-040	SHEET 2 of 5