

Origination Form

Proposed Revisions to a Standard Plans Index

Originator:	Turley, Joshua	Index Number:	700-020
Date:	4/3/2024	Sheet Number(s):	2
E-mail:	Joshua.Turley@dot.state.fl.us	Index Title:	MULTI-COLUMN GROUND SIGN

Summary of the changes:

Sheet 2: Adding casting hole option in the stub column to allow for horizontal precast casting. Modifying foundation detail to show the holes.

Commentary/Background:

Precaster requested the casting holes so that they could cast horizontally and not get voids around the embed caused by trapped pockets of air. The holes allow the air bubbles to escape during vibration.

Other Affected Documents/Offices	Person Contacted	Affected (Yes/No)
Other Standard Plans		No
FDOT Design Manual		No
Standard Specifications		No
Basis of Estimates Manual		No
Approved Product List		No
Construction Office		No
Maintenance Office		No

Implementation

["FY-Standard Plans (Next Release)"]

STATE OF FLORIDA
WELCOME CENTER

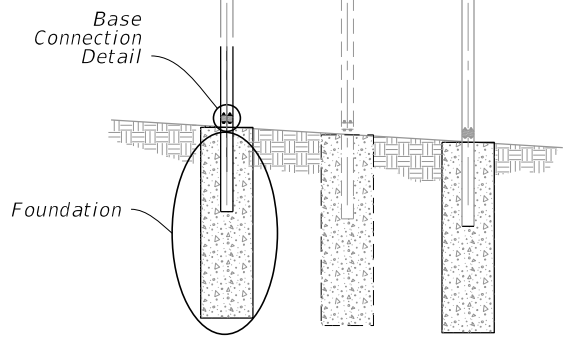

FOUNDATION DATA				
Steel Post & Stub Section*	Dia.	Depth	Stub Column Length	Reinf. Bars V
S 3x5.7	2'-0"	4'-0"	3'-0"	10-#6
W 6x12	2'-0"	6'-0"	3'-0"	10-#6
W 8x18	2'-4"	7'-6"	4'-0"	8-#8
W 8x24	2'-4"	8'-6"	4'-0"	8-#8
W 10x33	2'-4"	10'-3"	4'-0"	8-#8
W 12x45	2'-8"	11'-3"	5'-0"	10-#8

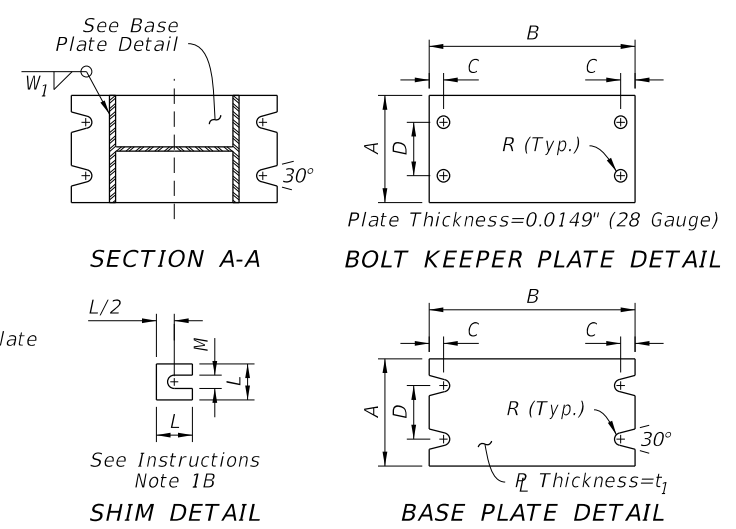
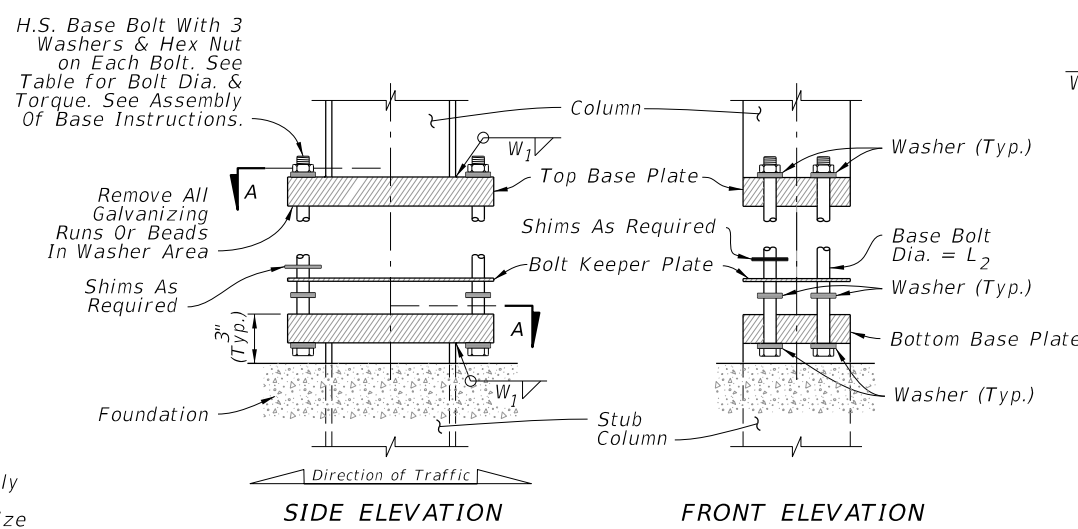
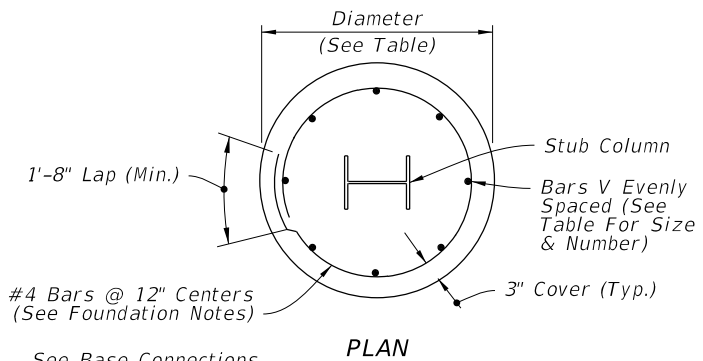

Steel Post & Stub Section*	BASE CONNECTION DATA								SHIM		
	A	B	C	D	R	t ₁	L ₂	W ₁	Torque (lbf*in)	L	M
S 3x5.7	4"	7"	3/4"	2"	5/16"	1"	1/2"	1/4"	90 ± 20	1-1/4"	9/16"
W 6x12	4"	10"	3/4"	2"	3/8"	1-5/8"	5/8"	1/4"	270 ± 45	1-3/8"	11/16"
W 8x18	5-1/4"	12-1/2"	7/8"	2-3/4"	7/16"	1-3/4"	3/4"	3/8"	445 ± 75	1-3/4"	13/16"
W 8x24	6-1/2"	12-1/2"	7/8"	3-1/4"	7/16"	1-3/4"	3/4"	3/8"	445 ± 75	2-1/8"	13/16"
W 10x33	8"	16"	1-1/4"	4-3/4"	9/16"	2"	1"	1/2"	580 ± 90	2-3/8"	1-1/16"
W 12x45	10"	18"	1-1/4"	6"	9/16"	2"	1"	1/2"	580 ± 90	2-3/4"	1-1/16"

* Designations: (Nominal Depth in inches) x (weight in pounds per linear foot).

MULTI-COLUMN SIGN ASSEMBLY

FOUNDATION NOTES:

The foundation may be either precast or cast-in-place. Use Reinforcing bars or equivalent Welded Wire Reinforcement.

At the Contractor's option, the #4 tie bars at 12" o.c. may be replaced by D10 Spiral Wire @ 6" pitch, with three flat turns at the top and one flat turn at the bottom in accordance with Specification 415.

For precast foundations, the circular cross section shown may be substituted with an octagon shape. The out-to-out distance between parallel edges must be greater than or equal to the diameter in the Foundation Data table. Use the same reinforcing diameter with centered placement and a minimum 3" cover.

BASE CONNECTION NOTES:

- Assembly of Base Instructions:
 - Place one washer on each Base Bolt between the Bottom Base Plate and the head of high strength Base Bolt; place the next washer between the Bottom Base Plate and the Bolt Keeper Plate; add the Top Base Plate section and place the third washer between the Top Base Plate and the Nut.
 - Shim as required to plumb column. Provide 2-0.0149" thick (28 gauge) and 2-0.0329" thick (21 gauge) shims per column.
- H.S. Base Bolt L Tightening Instructions:
 - Tighten Base Bolts to the maximum possible with a 12" to 15" wrench (this will bed the washers and shims and clear the bolt threads).
 - Loosen each Base Bolt one turn.
 - Under the supervision of the Engineer, use a calibrated wrench to tighten bolts to the torque prescribed in the Table. Over tightened Base Bolts will not be permitted.
 - Burr threads at junction with nut to prevent nut loosening. Treat damaged galvanizing.
- Assemble Post to Stub with Base Bolts and three flat washers per bolt (See Base Connection Details). Tighten Base Bolts in accordance with Instructions with Note 2.
- Weld Base Plate to Post & Stub or if using the Alternate Connection Detail weld Base Plate and Stiffeners to Post and Stub.
- Orient Stub Post according to direction of traffic.

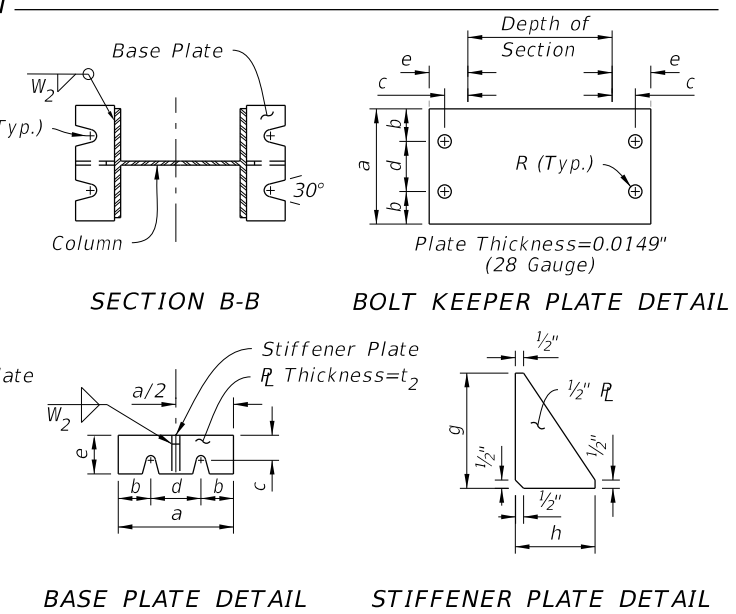
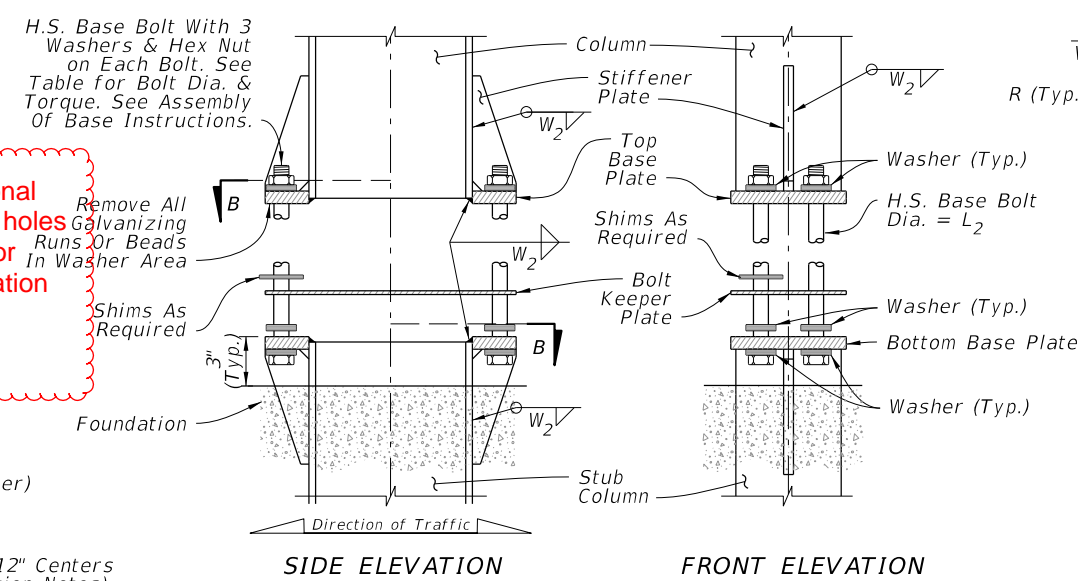
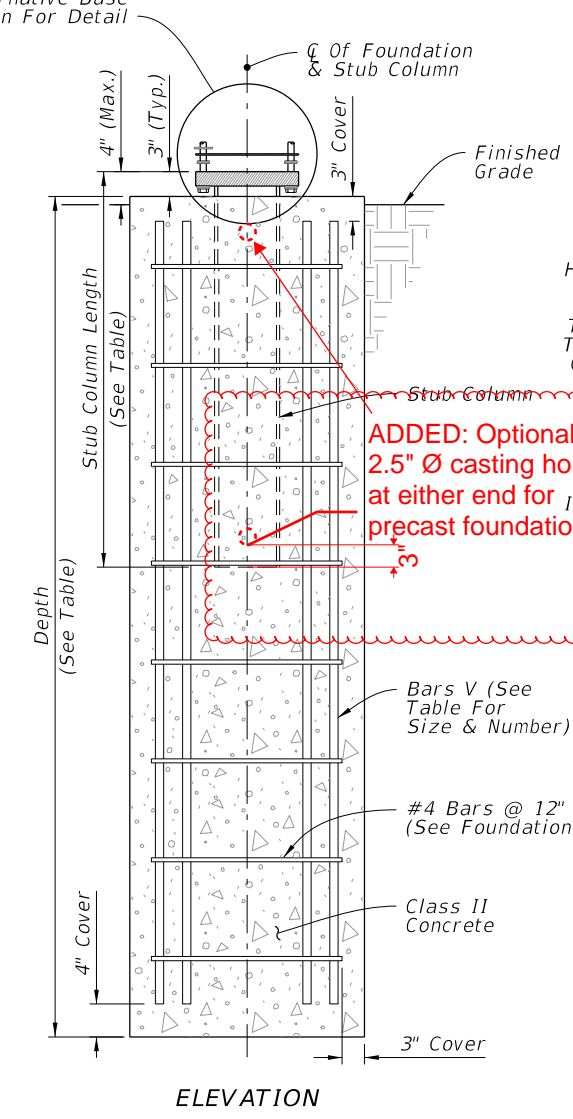

Steel Section*	ALTERNATIVE BASE CONNECTION DATA											
	a	b	c	d	e	t ₂	L ₂	R	Torque (lbf*in)	g	h	W ₂
W 6x12	4-3/4"	1-1/8"	1-3/16"	2-1/2"	2"	1/2"	5/8"	3/8"	270 ± 45	5-1/8"	2"	1/4"
W 8x18	5-3/4"	1-1/2"	1-3/8"	2-3/4"	2-3/16"	5/8"	3/4"	7/16"	445 ± 75	6-1/4"	2-3/16"	1/4"
W 8x24	7"	1-3/4"	1-3/8"	3-1/2"	2-3/8"	3/4"	3/4"	7/16"	445 ± 75	8"	2-3/8"	5/16"
W 10x33	8"	2"	1-9/16"	4"	2-3/4"	3/4"	1"	9/16"	580 ± 90	8"	2-3/4"	5/16"
W 12x45	8"	2"	1-9/16"	4"	3"	3/4"	1"	9/16"	580 ± 90	8"	3"	5/16"

* Designations: (Nominal Depth in inches) x (weight in pounds per linear foot).

ALTERNATIVE BASE CONNECTION

FOUNDATION AND BASE CONNECTION DETAILS

10/3/2023 3:01:56 PM

STATE OF FLORIDA
WELCOME CENTER

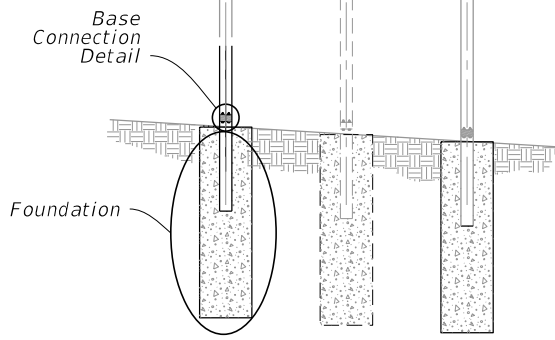

FOUNDATION DATA				
Steel Post & Stub Section*	Dia.	Depth	Stub Column Length	Reinf. Bars V
S 3x5.7	2'-0"	4'-0"	3'-0"	10-#6
W 6x12	2'-0"	6'-0"	3'-0"	10-#6
W 8x18	2'-4"	7'-6"	4'-0"	8-#8
W 8x24	2'-4"	8'-6"	4'-0"	8-#8
W 10x33	2'-4"	10'-3"	4'-0"	8-#8
W 12x45	2'-8"	11'-3"	5'-0"	10-#8

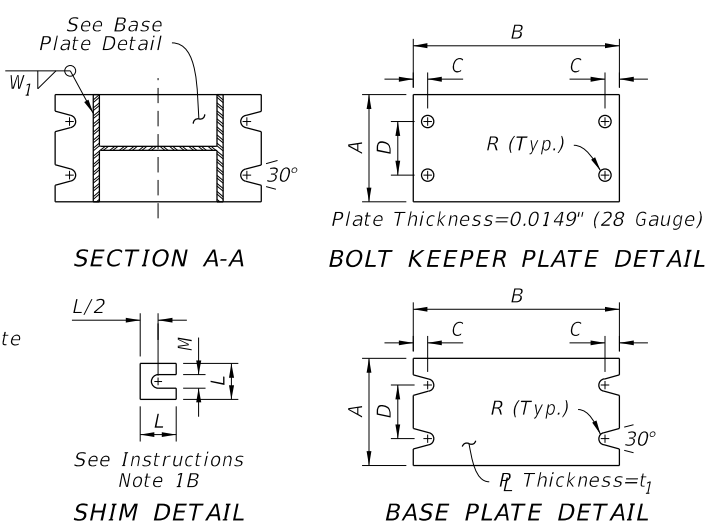
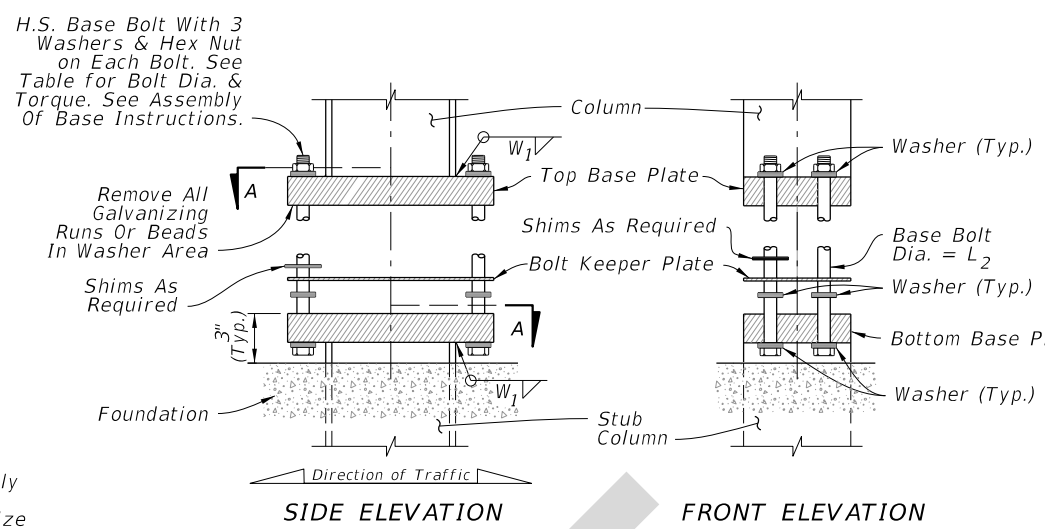
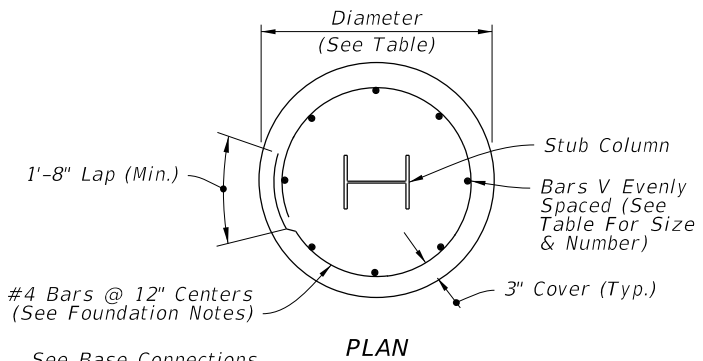

Steel Post & Stub Section*	BASE CONNECTION DATA								SHIM		
	A	B	C	D	R	t ₁	L ₂	W ₁	Torque (lbf*in)	L	M
S 3x5.7	4"	7"	3/4"	2"	5/16"	1"	1/2"	1/4"	90 ± 20	1-1/4"	9/16"
W 6x12	4"	10"	3/4"	2"	3/8"	1-5/8"	5/8"	1/4"	270 ± 45	1-3/8"	11/16"
W 8x18	5-1/4"	12-1/2"	7/8"	2-3/4"	7/16"	1-3/4"	3/4"	3/8"	445 ± 75	1-3/4"	13/16"
W 8x24	6-1/2"	12-1/2"	7/8"	3-1/4"	7/16"	1-3/4"	3/4"	3/8"	445 ± 75	2-1/8"	13/16"
W 10x33	8"	16"	1-1/4"	4-3/4"	9/16"	2"	1"	1/2"	580 ± 90	2-3/8"	1-1/16"
W 12x45	10"	18"	1-1/4"	6"	9/16"	2"	1"	1/2"	580 ± 90	2-3/4"	1-1/16"

* Designations: (Nominal Depth in inches) x (weight in pounds per linear foot).

MULTI-COLUMN SIGN ASSEMBLY

FOUNDATION NOTES:

The foundation may be either precast or cast-in-place. Use Reinforcing bars or equivalent Welded Wire Reinforcement.

At the Contractor's option, the #4 tie bars at 12" o.c. may be replaced by D10 Spiral Wire @ 6" pitch, with three flat turns at the top and one flat turn at the bottom in accordance with Specification 415.

For precast foundations, the circular cross section shown may be substituted with an octagon shape. The out-to-out distance between parallel edges must be greater than or equal to the diameter in the Foundation Data table. Use the same reinforcing diameter with centered placement and a minimum 3" cover.

BASE CONNECTION NOTES:

- Assembly of Base Instructions:
 - Place one washer on each Base Bolt between the Bottom Base Plate and the head of high strength Base Bolt; place the next washer between the Bottom Base Plate and the Bolt Keeper Plate; add the Top Base Plate section and place the third washer between the Top Base Plate and the Nut.
 - Shim as required to plumb column. Provide 2-0.0149" thick (28 gauge) and 2-0.0329" thick (21 gauge) shims per column.
- H.S. Base Bolt L Tightening Instructions:
 - Tighten Base Bolts to the maximum possible with a 12" to 15" wrench (this will bed the washers and shims and clear the bolt threads).
 - Loosen each Base Bolt one turn.
 - Under the supervision of the Engineer, use a calibrated wrench to tighten bolts to the torque prescribed in the Table. Over tightened Base Bolts will not be permitted.
 - Burr threads at junction with nut to prevent nut loosening. Treat damaged galvanizing.
- Assemble Post to Stub with Base Bolts and three flat washers per bolt (See Base Connection Details). Tighten Base Bolts in accordance with Instructions with Note 2.
- Weld Base Plate to Post & Stub or if using the Alternate Connection Detail weld Base Plate and Stiffeners to Post and Stub.
- Orient Stub Post according to direction of traffic.

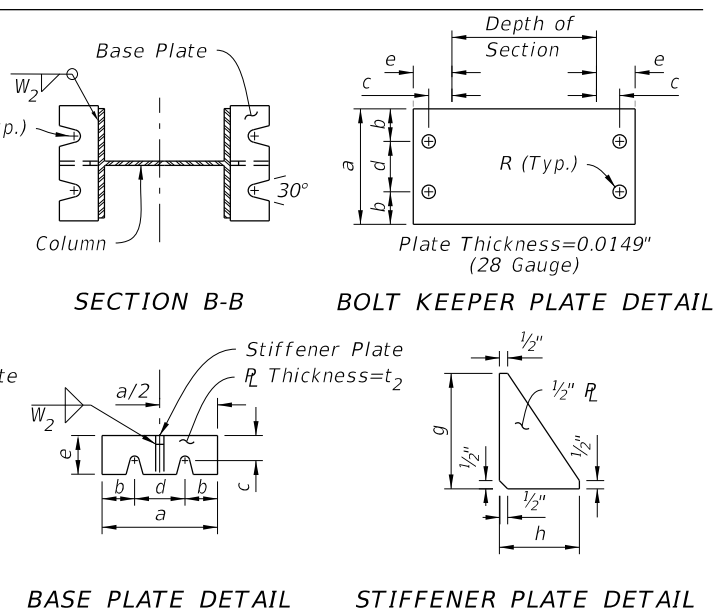
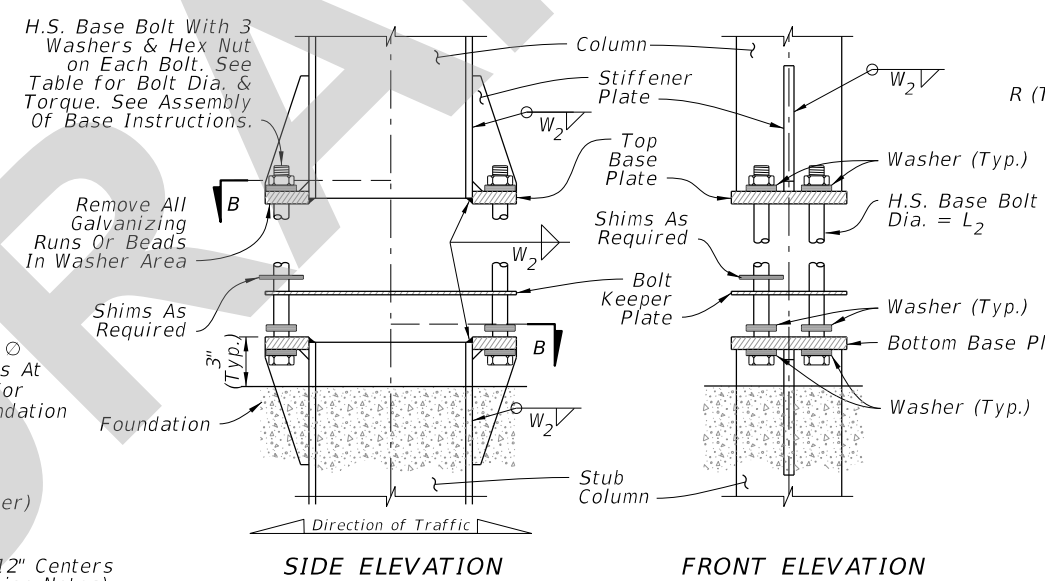
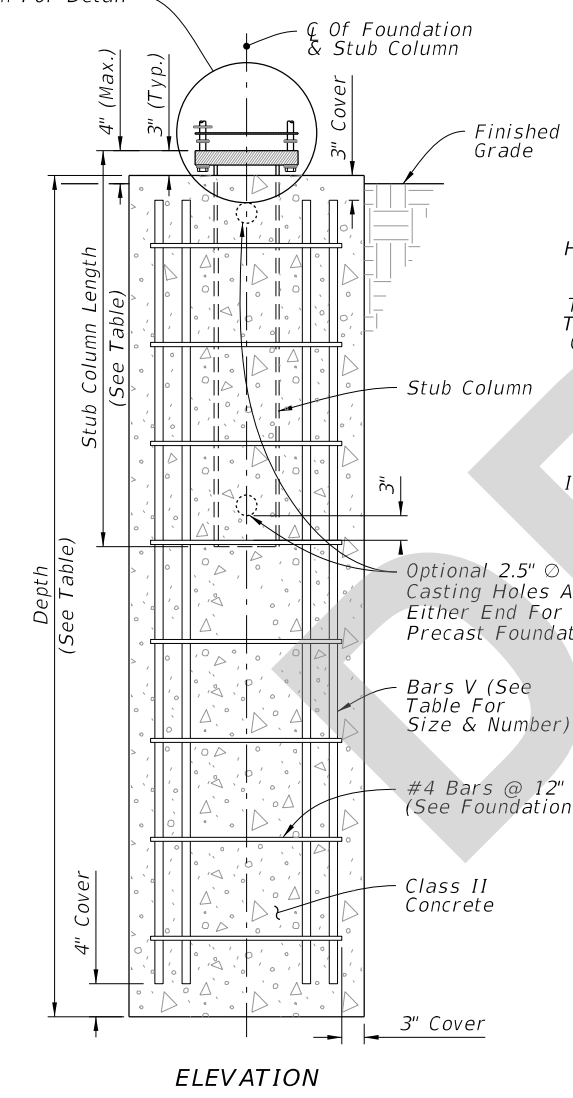

ALTERNATIVE BASE CONNECTION DATA												
Steel Section*	a	b	c	d	e	t ₂	L ₂	R	Torque (lbf*in)	g	h	W ₂
W 6x12	4-3/4"	1-1/8"	1-3/16"	2-1/2"	2"	1/2"	5/8"	3/8"	270 ± 45	5-1/8"	2"	1/4"
W 8x18	5-3/4"	1-1/2"	1-3/8"	2-3/4"	2-3/16"	5/8"	3/4"	7/16"	445 ± 75	6-1/4"	2-3/16"	1/4"
W 8x24	7"	1-3/4"	1-3/8"	3-1/2"	2-3/8"	3/4"	3/4"	7/16"	445 ± 75	8"	2-3/8"	5/16"
W 10x33	8"	2"	1-9/16"	4"	2-3/4"	3/4"	1"	9/16"	580 ± 90	8"	2-3/4"	5/16"
W 12x45	8"	2"	1-9/16"	4"	3"	3/4"	1"	9/16"	580 ± 90	8"	3"	5/16"

* Designations: (Nominal Depth in inches) x (weight in pounds per linear foot).

ALTERNATIVE BASE CONNECTION

FOUNDATION AND BASE CONNECTION DETAILS

6/18/2024 9:23:04 AM

LAST REVISION 11/01/24	DESCRIPTION:	FDOT	FY 2025-26 STANDARD PLANS	MULTI-COLUMN GROUND SIGN	INDEX 700-020	SHEET 2 of 3
---------------------------	--------------	------	------------------------------	--------------------------	------------------	-----------------