

Origination Form

Proposed Revisions to a Standard Plans Index

Originator:	Stutts, Dylan	Index Number:	700-010
Date:	6/27/2024	Sheet Number(s):	1, 7
E-mail:	Dylan.Stutts@dot.state.fl.us	Index Title:	SINGLE COLUMN GROUND SIGNS

Summary of the changes:

Sheet 1: Updated Table of Contents

Sheet 7: Updated the flip sign to allow for multiple sign panels; Removed the diamond sign panel; Updated Note 1 to "Install sign with the ESU sign panel in the undeployed (up) position."; Added Note 5 "Multi sign panel assembly only use one of the following approved signs, actual sign may need to be scaled: FTP 43-06, FTP 47-06, and FTP 66-21."; Added ESU to sheet title

Commentary/Background:

The changes are coming from head of CO Traffic ops based on request from DTOEs to allow for multiple sign panels on the ESU flip sign. Updated the Standard Plan to allow for two sign panels which were approved by CO Traffic Ops. During ESU meeting districts request the use of static sign while ESU sign was not deployed. Removed the diamond sign panel as this is not used for permanent ESU signs.

Other Affected Documents/Offices	Person Contacted	Affected (Yes/No)
Other Standard Plans		No
FDOT Design Manual		No
Standard Specifications		No
Basis of Estimates Manual		No
Approved Product List		No
Construction Office		No
Maintenance Office		No

Implementation

["FY-Standard Plans (Next Release)"]

GENERAL NOTES:

1. Meet the requirements of Specification 700.
2. Shop Drawings:
This Index is considered fully detailed. Submit Shop Drawings only for minor modifications not detailed in the Plans.
3. BREAKAWAY SUPPORTS REQUIREMENTS: Install non-frangible aluminum column (post) (larger than 3 1/2") with breakaway supports as shown on Sheet 4. Signs shielded by barrier wall or guardrail do not require breakaway support.

STEP 1: Calculate the area and the centroid for an individual sign or a sign cluster. Note that the centroid and areas have been calculated for frequently used sign clusters. These are shown on Sheets 7, 8, and 9.

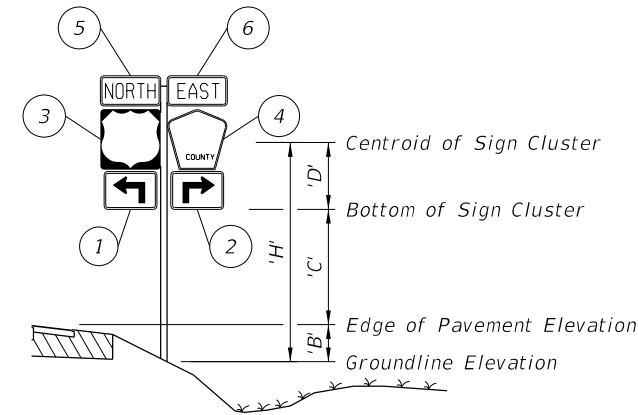

Size a x h	Centroid			'A _n	'X _n x 'A _n	'Y _n x 'A _n
	Local 'Y _n	Global 'X _n	Global 'Y _n			
(in. x in.)	(in.)	(in.)		(in. ²)	(in. ³)	(in. ³)
1	21 x 15	7.5	-10.5-1.5-1.5 = -13.5	7.5	315	-4,252.5
2	21 x 15	7.5	10.5+1.5+1.5 = 13.5	7.5	315	+4,252.5
3	24 x 24	12	-12-1.5 = -13.5	15+1+12 = 28	576	-7,776
4	24 x 24	12	12+1.5 = 13.5	15+1+12 = 28	436	5,886
5	24 x 12	6	-12-1.5 = -13.5	15+1+24+1+6 = 47	288	-3,888
6	24 x 12	6	12+1.5 = 13.5	15+1+24+1+6 = 47	288	3,888
TOTALS				2,218	-1,890	60,133

$$\Sigma ('A_n') = 2,218 \text{ in.}^2 = 15.4 \text{ ft.}^2 \quad \Sigma ('X_n' \times 'A_n') = -1,890 \text{ in.}^3 = -1.09 \text{ ft.}^3 \quad \Sigma ('Y_n' \times 'A_n') = 60,133 \text{ in.}^3 = 34.8 \text{ ft.}^3$$

$$'X_c' = \frac{\Sigma ('X_n' \times 'A_n')}{\Sigma 'A_n'} = -0.1 \text{ ft.} \quad 'Y_c' = \frac{\Sigma ('Y_n' \times 'A_n')}{\Sigma 'A_n'} = 2.26 \text{ ft.}$$

STEP 2: Determine the height 'H' from groundline to the centroid of the individual sign or sign cluster.

Assume: 'B' = 1 ft., 'C' = 7 ft.
Calculated: 'X_c' = -0.1 ft., 'Y_c' = 'D' 2.26 ft.

'H' = 'B' + 'C' + 'D' = 10.26 ft. ==> **USE 11 ft.** $\Sigma ('A_n') = 15.4 \text{ ft.}^2$ ==> **USE 16 ft.²**

STEP 3: Refer to the Aluminum Column (Post) Selection Tables and find the intersection point. See Sheet 3.

SHEET	CONTENTS
1	General Notes and Design Example
2	Design Example - Centroid
3	Column and Foundation Tables
4	Slip Base and Foundation Details
5	Driven Post, Concrete Stub, and Soil Plate Details
6	Wind Beam Connection
7	Wind Beam Connection for Flip Down Sign
8	Slap-Latch Detail
9, 10, & 11	Frequently Used Sign Clusters

UPDATED to Wind Beam Connection for ESU Flip Signs

TOTAL PANEL AREA (SF)	'H' (FT)												
	8 ft	9 ft	10 ft	11 ft	12 ft	13 ft	14 ft	15 ft	16 ft	17 ft	18 ft	19 ft	20 ft
3 sf	2	2.5	2.5	2.5	3	3	3	3	3.5	3.5	3.5	3.5	3.5
4 sf	2.5	2.5	3	3	3	3	3.5	3.5	3.5	3.5	3.5	3.5	3.5
5 sf	2.5	3	3	3	3.5	3.5	3.5	3.5	3.5	3.5	3.5	4	4
6 sf	3	3	3.5	3.5	3.5	3.5	3.5	3.5	3.5	3.5	4	4	4
7 sf	3	3.5	3.5	3.5	3.5	3.5	3.5	3.5	4	4	4	4	4
8 sf	3.5	3.5	3.5	3.5	3.5	3.5	3.5	4	4	4	4	4	4
9 sf	3.5	3.5	3.5	3.5	3.5	3.5	4	4	4	4	4	4	4
10 sf	3.5	3.5	3.5	3.5	3.5	4	4	4	4	4	4	4.5	4.5
11 sf	3.5	3.5	3.5	3.5	4	4	4	4	4	4	4	4.5	4.5
12 sf	3.5	3.5	3.5	4	4	4	4	4	4	4	4	4.5	4.5
13 sf	3.5	3.5	4	4	4	4	4	4	4	4	4.5	4.5	5
14 sf	3.5	3.5	4	4	4	4	4	4	4	4.5	4.5	4.5	5
15 sf	3.5	4	4	4	4	4	4	4	4.5	4.5	4.5	5	5
16 sf	3.5	4	4	4	4	4	4	4	4.5	4.5	5	5	6
17 sf	4	4	4	4	4	4	4	4	4.5	4.5	4.5	5	6
18 sf	4	4	4	4	4	4	4.5	4.5	4.5	5	5	5	6
19 sf	4	4	4	4	4	4	4.5	4.5	4.5	5	5	6	6
20 sf	4	4	4	4	4	4	4.5	4.5	4.5	5	5	6	6
21 sf	4	4	4	4	4	4.5	4.5	5	5	5	6	6	6
22 sf	4	4	4	4	4.5	4.5	4.5	5	5	6	6	6	6
23 sf	4	4	4	4	4.5	4.5	5	5	5	6	6	6	6
24 sf	4	4	4	4.5	4.5	4.5	5	5	6	6	6	6	6
25 sf	4	4	4	4.5	4.5	5	5	5	6	6	6	6	8
26 sf	4	4.5	4.5	4.5	5	5	5	5	6	6	6	6	8
27 sf	4	4.5	4.5	4.5	5	5	6	6	6	6	6	6	8
28 sf	4	4.5	4.5	5	5	5	6	6	6	6	6	6	8
29 sf	4.5	4.5	4.5	5	5	6	6	6	6	6	6	8	8
30 sf	4.5	4.5	5	5	5	6	6	6	6	6	8	8	8

For 'H' = 11 ft., Area = 16 ft.²

- Refer to the Aluminum Column (Post) Selection Table, from Sheet 3 and shown here for reference.

- To determine the required post size, find the intersection of the row labeled "16 SF" and the column labeled "11 FT". For the example the intersection value is "4" (4" OD).

- In the Column (Post) and Foundation Table, the value "4" shows the design requires a 4.0" diameter and 1/4" thick Aluminum Column (Post) and a 2.0' diameter and 3.5' deep Concrete Foundation and 3.0' Stub.

STEP 4: For sign assemblies with signs oriented in two directions, only the sign with the largest area should be analyzed to determine the Column (Post) requirements.

GUIDE TO USE THIS INDEX

GENERAL NOTES AND DESIGN EXAMPLE

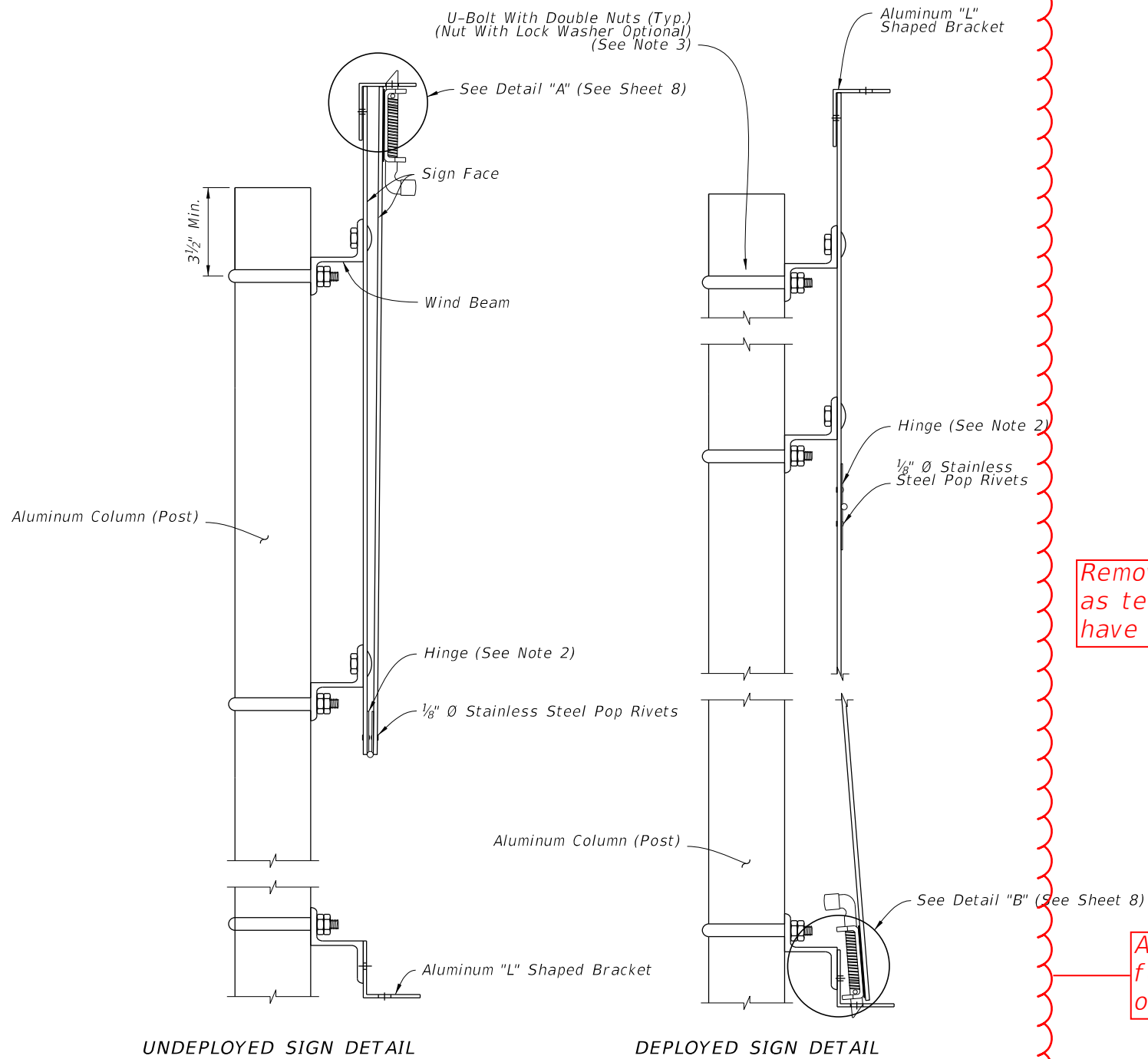

UNDEPLOYED SIGN DETAIL

DEPLOYED SIGN DETAIL

SIGN PANEL SIDE VIEW

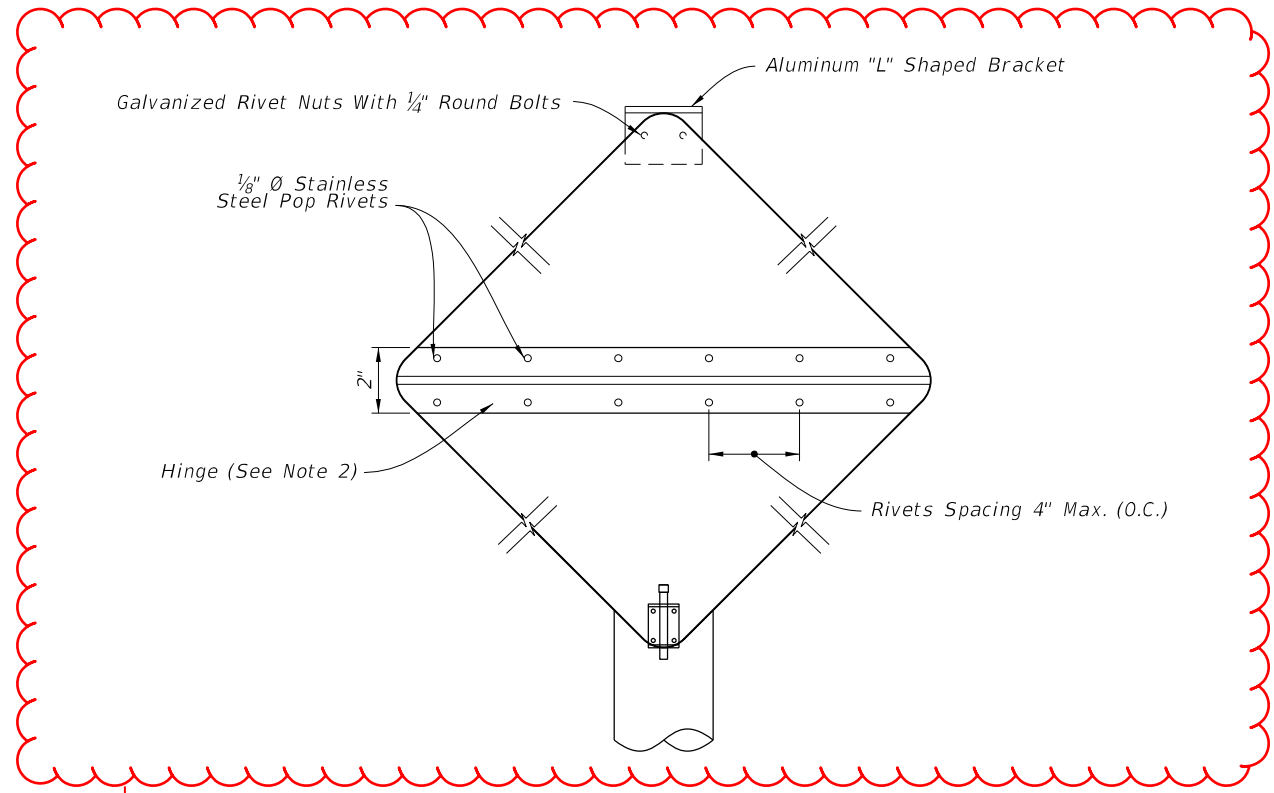

Removed the diamond sign panel as temporary ESU signs will not have the flip down option.

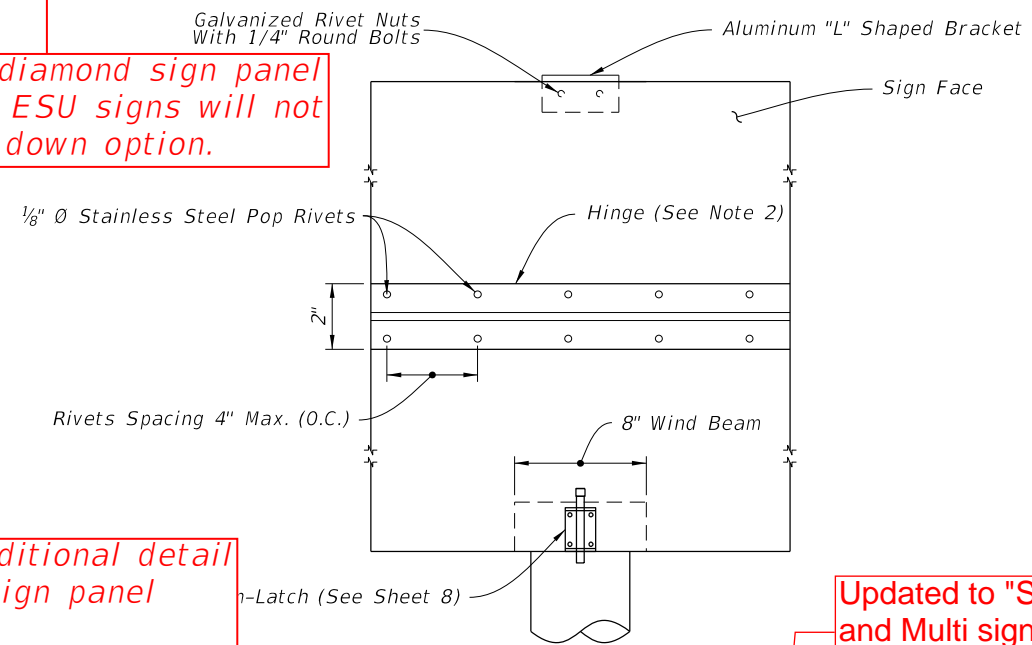

SIGN PANEL FRONT VIEW

Updated to "Single and Multi sign panel front view"

Added additional detail for two sign panel option

NOTES:

1. Install sign in the undeployed (up) position.
2. Provide a continuous stainless steel hinge with minimum 0.060" leaf thickness, 2" open width and 0.120" pin diameter.
3. Install Stainless Steel Spring Loaded Slam-Latch with cover to bottom face of flip sign per manufacturer's instructions.
4. Punch or drill a 3/4" diameter hole in the "L" shaped bracket on site to match location of 1/2" wide slam-latch.

Added Note 5: Multi sign panel assembly only use one of the following approved signs messages, actual sign may need to be scaled: FTP 43-06, FTP 47-06, and FTP 66-21.

Added ESU between "For" and "Flip"

WIND BEAM CONNECTION FOR FLIP DOWN SIGN

10/3/2023

2025-26

LAST REVISION	DESCRIPTION:
11/01/22	
11/01/24	



FY 2024-25
STANDARD PLANS

SINGLE COLUMN GROUND SIGNS

INDEX
700-010

SHEET
7 of 11

GENERAL NOTES:

1. Meet the requirements of Specification 700.
2. Shop Drawings:
This Index is considered fully detailed. Submit Shop Drawings only for minor modifications not detailed in the Plans.
3. BREAKAWAY SUPPORTS REQUIREMENTS: Install non-frangible aluminum column (post) (larger than 3½") with breakaway supports as shown on Sheet 4. Signs shielded by barrier wall or guardrail do not require breakaway support.
4. Aluminum Sign, Wind Beams and Column (Post) Materials:
 - A. Aluminum Plates: ASTM B209, Alloy 6061-T6
 - B. Aluminum Bars and Extruded Shapes: ASTM B221, Alloy 6061-T6
 - C. Aluminum Structural Shapes: ASTM B221 Alloy 6061-T6
 - D. Cast Aluminum: ASTM B26 Alloy A356-T6
5. Galvanized Steel Slip Base Stub Materials:
 - A. Steel Plate and Structural Shapes: ASTM A36 or ASTM A709, Grade 36
6. Sign Mounting Bolts, Nuts and Washers:
 - A. Aluminum Button Head and Flat Head Bolts: ASTM F468 Alloy 2024-T4
 - B. Aluminum Hex Nuts: ASTM F467 Alloy 6061-T6 or 6262-T9
 - C. Aluminum Washers: ASTM B221, Alloy 7075-T6
7. Stainless Steel Bolts, Nuts and Washers may be used in lieu of the Aluminum button head and flat head bolts as follows:
 - A. Stainless Steel Bolts: ASTM F593 Alloy Group 2, Condition A, CW1 or SH1
 - B. Stainless Steel Nuts: ASTM F594
8. Sign Column (Post) Bolts, Nuts and Washers:
 - A. Galvanized U-Bolt (Column): ASTM A449 or ASTM A193 B7 according to ASTM F2329 with double nuts (nut and lock washer optional).
 - B. Aluminum Bolts (Sleeve): ASTM F468, Alloy 6061-T6 or 2024-T4 with Hex Nuts F467 6061-T6 or 6262-T9 and Washers B221, Al clad 2024-T4
 - C. Galvanized High Strength Hex Head Bolts (BaseBolts): ASTM F3125, Grade A325, Type 1
 - D. Galvanized Hex Nuts: ASTM A563 Grade D
 - E. Galvanized Washers: ASTM F436
 - F. Galvanized Bolts (Sleeve): ASTM A307 with Galvanized Hex Nuts and Washers

SHEET	CONTENTS
1	General Notes and Design Example
2	Design Example - Centroid
3	Column and Foundation Tables
4	Slip Base and Foundation Details
5	Driven Post, Concrete Stub, and Soil Plate Details
6	Wind Beam Connection
7	Wind Beam Connection for ESU Flip Signs
8	Slam-Latch Detail
9, 10, & 11	Frequently Used Sign Clusters

STEP 1: Calculate the area and the centroid for an individual sign or a sign cluster. Note that the centroid and areas have been calculated for frequently used sign clusters. These are shown on Sheets 7, 8, and 9.

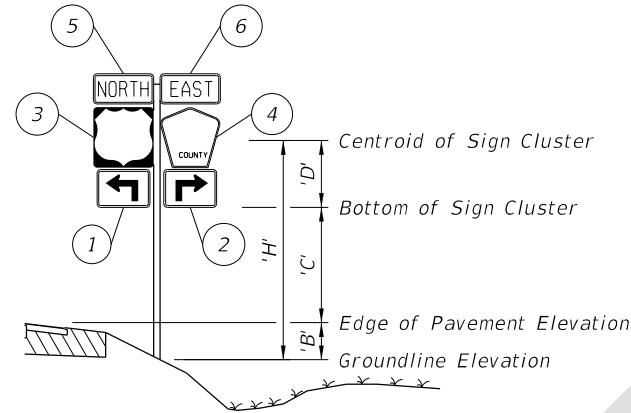

Size a x h	Centroid			'A _n	'X _n x 'A _n	'Y _n x 'A _n
	Local 'Y _n	Global 'X _n	Global 'Y _n			
(in. x in.)	(in.)	(in.)		(in. ²)	(in. ³)	(in. ³)
1 21 x 15	7.5	-10.5-1.5-1.5 = -13.5	7.5	315	-4,252.5	2,362.5
2 21 x 15	7.5	10.5+1.5+1.5 = 13.5	7.5	315	+4,252.5	2,362.5
3 24 x 24	12	-12-1.5 = -13.5	15+1+12 = 28	576	-7,776	16,128
4 24 x 24	12	12+1.5 = 13.5	15+1+12 = 28	436	5,886	12,208
5 24 x 12	6	-12-1.5 = -13.5	15+1+24+1+6 = 47	288	-3,888	13,536
6 24 x 12	6	12+1.5 = 13.5	15+1+24+1+6 = 47	288	3,888	13,536
TOTALS				2,218	-1,890	60,133

$$\Sigma (A_n) = 2,218 \text{ in.}^2 = 15.4 \text{ ft.}^2 \quad \Sigma (X_n \times A_n) = -1,890 \text{ in.}^3 = -1.09 \text{ ft.}^3 \quad \Sigma (Y_n \times A_n) = 60,133 \text{ in.}^3 = 34.8 \text{ ft.}^3$$

$$X_c = \frac{\Sigma (X_n \times A_n)}{\Sigma A_n} = -0.1 \text{ ft.} \quad Y_c = \frac{\Sigma (Y_n \times A_n)}{\Sigma A_n} = 2.26 \text{ ft.}$$

STEP 2: Determine the height 'H' from groundline to the centroid of the individual sign or sign cluster.

Assume: 'B' = 1 ft., 'C' = 7 ft.
Calculated: X_c = -0.1 ft., Y_c = 'D' 2.26 ft.

'H' = 'B' + 'C' + 'D' = 10.26 ft. ==> **USE 11 ft.** Σ (A_n) = 15.4 ft.² ==> **USE 16 ft.²**

STEP 3: Refer to the Aluminum Column (Post) Selection Tables and find the intersection point. See Sheet 3.

TOTAL PANEL AREA (SF)	'H' (FT)												
	8 ft	9 ft	10 ft	11 ft	12 ft	13 ft	14 ft	15 ft	16 ft	17 ft	18 ft	19 ft	20 ft
3 sf	2	2.5	2.5	2.5	3	3	3	3	3.5	3.5	3.5	3.5	3.5
4 sf	2.5	2.5	3	3	3	3	3.5	3.5	3.5	3.5	3.5	3.5	3.5
5 sf	2.5	3	3	3	3.5	3.5	3.5	3.5	3.5	3.5	3.5	4	4
6 sf	3	3	3.5	3.5	3.5	3.5	3.5	3.5	3.5	3.5	4	4	4
7 sf	3	3.5	3.5	3.5	3.5	3.5	3.5	3.5	4	4	4	4	4
8 sf	3.5	3.5	3.5	3.5	3.5	3.5	3.5	4	4	4	4	4	4
9 sf	3.5	3.5	3.5	3.5	3.5	3.5	4	4	4	4	4	4	4
10 sf	3.5	3.5	3.5	3.5	3.5	4	4	4	4	4	4	4.5	4.5
11 sf	3.5	3.5	3.5	3.5	4	4	4	4	4	4	4	4.5	4.5
12 sf	3.5	3.5	3.5	4	4	4	4	4	4	4	4	4.5	4.5
13 sf	3.5	3.5	4	4	4	4	4	4	4	4	4.5	4.5	4.5
14 sf	3.5	3.5	4	4	4	4	4	4	4	4.5	4.5	4.5	5
15 sf	3.5	4	4	4	4	4	4	4.5	4.5	4.5	5	5	5
16 sf	3.5	4	4	4	4	4	4	4.5	4.5	5	5	5	6
17 sf	4	4	4	4	4	4	4	4.5	4.5	4.5	5	5	6
18 sf	4	4	4	4	4	4	4.5	4.5	4.5	5	5	5	6
19 sf	4	4	4	4	4	4	4.5	4.5	4.5	5	5	6	6
20 sf	4	4	4	4	4	4	4.5	4.5	4.5	5	5	6	6
21 sf	4	4	4	4	4	4	4.5	4.5	5	5	5	6	6
22 sf	4	4	4	4	4	4	4.5	4.5	5	5	6	6	6
23 sf	4	4	4	4	4	4	4.5	4.5	5	5	6	6	6
24 sf	4	4	4	4	4	4	4.5	4.5	5	5	6	6	6
25 sf	4	4	4	4	4	4	4.5	4.5	5	5	6	6	6
26 sf	4	4	4	4	4	4	4.5	4.5	5	5	6	6	6
27 sf	4	4	4	4	4	4	4.5	4.5	5	5	6	6	6
28 sf	4	4	4	4	4	4	4.5	4.5	5	5	6	6	6
29 sf	4	4	4	4	4	4	4.5	4.5	5	5	6	6	6
30 sf	4	4	4	4	4	4	4.5	4.5	5	5	6	6	6

For 'H' = 11 ft., Area = 16 ft.²

- Refer to the Aluminum Column (Post) Selection Table, from Sheet 3 and shown here for reference.

- To determine the required post size, find the intersection of the row labeled "16 SF" and the column labeled "11 FT". For the example the intersection value is "4" (4" OD).

- In the Column (Post) and Foundation Table, the value "4" shows the design requires a 4.0" diameter and ¼" thick Aluminum Column (Post) and a 2.0' diameter and 3.5' deep Concrete Foundation and 3.0' Stub.

STEP 4: For sign assemblies with signs oriented in two directions, only the sign with the largest area should be analyzed to determine the Column (Post) requirements.

GUIDE TO USE THIS INDEX

GENERAL NOTES AND DESIGN EXAMPLE

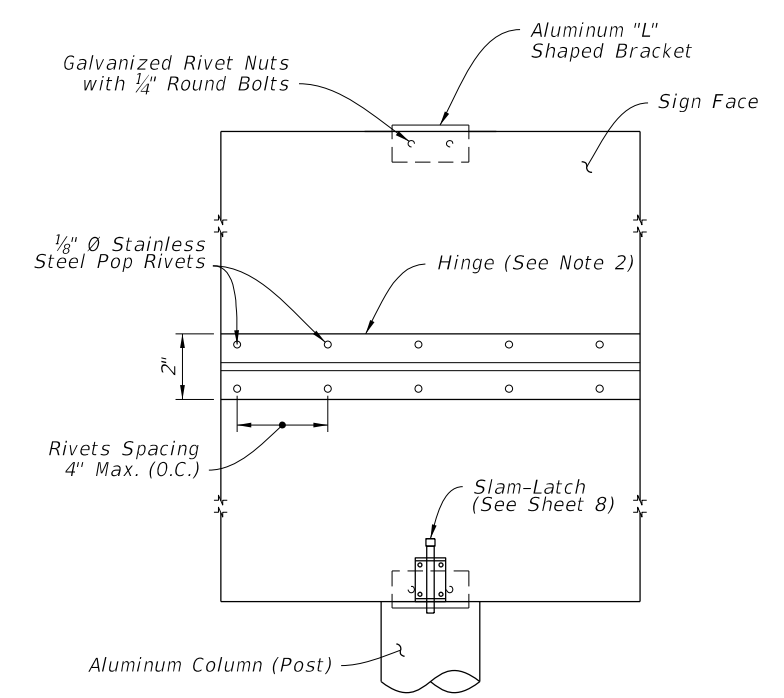
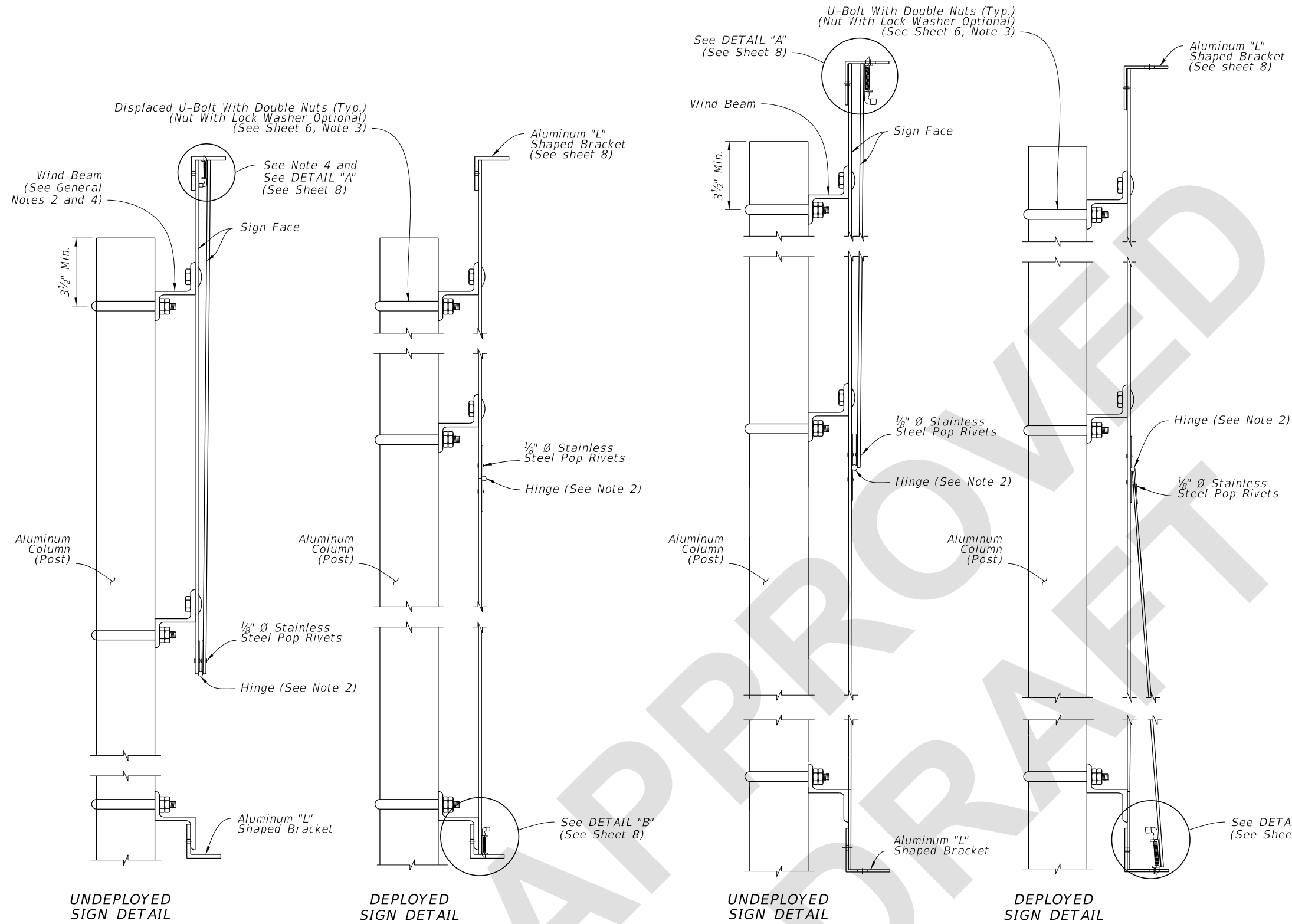

SINGLE & MULTI SIGN PANEL FRONT VIEW

UNDEPLOYED SIGN DETAIL

DEPLOYED SIGN DETAIL

UNDEPLOYED SIGN DETAIL

DEPLOYED SIGN DETAIL

SINGLE SIGN PANEL SIDE VIEW

MULTI SIGN PANEL SIDE VIEW

NOTES:

1. Install sign with ESU sign panel in the undeployed (up) position.
2. Provide a continuous stainless steel hinge with minimum 0.060" leaf thickness, 2" open width and 0.120" pin diameter. Stake the hinge at both ends to prevent pin movement.
3. Install Stainless Steel Spring Loaded Slam-Latch with cover to bottom face of flip sign per manufacturer's recommendations.
4. Punch or drill a 3/4" diameter hole in the "L" shaped bracket on site to match location of 1/2" wide slam-latch pin. Remove any burrs or sharp edges.
5. Multi sign panel assembly only use one of the following approved sign messages, actual sign may need to be scaled: FTP 43-06, FTP 47-06, and FTP 66-21.

WIND BEAM CONNECTION FOR ESU FLIP SIGNS

8/15/2024 8:04:08 AM

LAST REVISION 11/01/24	REVISION	DESCRIPTION:		FY 2025-26 STANDARD PLANS	SINGLE COLUMN GROUND SIGNS	INDEX 700-010	SHEET 7 of 11
---------------------------	----------	--------------	--	------------------------------	----------------------------	------------------	------------------