

# Origination Form

## Proposed Revisions to a Standard Plans Index

<b>Originator:</b>	Turley, Joshua	<b>Index Number:</b>	649-031
<b>Date:</b>	2/6/2024	<b>Sheet Number(s):</b>	2 and 6
<b>E-mail:</b>	Joshua.Turley@dot.state.fl.us	<b>Index Title:</b>	Mast Arm Assemblies

### Summary of the changes:

Sheet 2: Section A-A -- Corrected the label order of the anchor nut bolts. DETAIL "A" -- Removed welding hatches, Modified wall thickness from text to symbol.  
 Sheet 6: Removed weld hatches, Clarified Handhole labels

### Commentary/Background:

Sheet 2: Section A-A\_\_ There is an associated Spec change being drafted for Section 649 that pertains to process for tightening the anchor bolts. These changes make it so that the language aligns between the Spec and the Standard.  
 Sheet 2 and 6: Removing weld hatches to make consistent ith the rest of the Standards and also industry convention.

Other Affected Documents/Offices	Person Contacted	Affected (Yes/No)
Other Standard Plans		No
FDOT Design Manual		No
Standard Specifications	Daniel Strickland	Yes
Basis of Estimates Manual		No
Approved Product List		No
Construction Office		No
Maintenance Office		No

### Implementation

["FY-Standard Plans (Next Release)"]

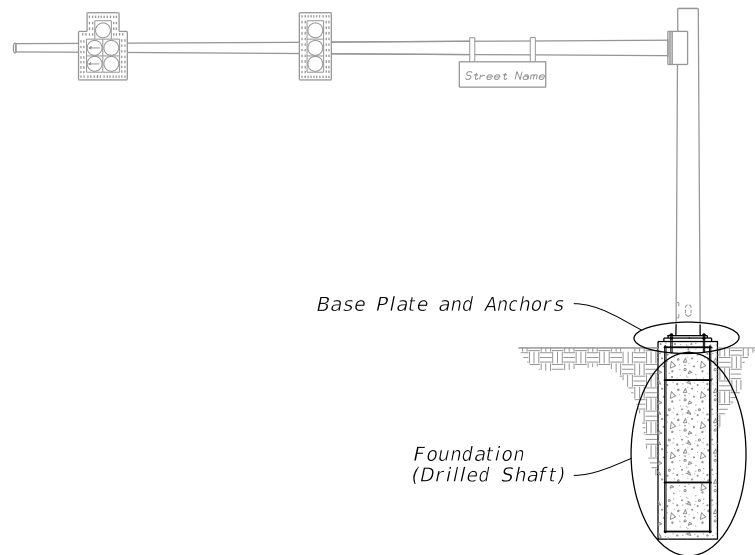

MAST ARM ASSEMBLY

NOTES:

1. The Structural Grout Pad diameter may be reduced where the footprint of the Grout Pad does not provide adequate clearance for the sidewalk and/or accessibility considerations.
2. See Index 649-030 and the plans for actual quantity of bolts in the Base Plate Connection.
3. The retainer nut shown in Section A-A may be half-height. Provide individual nut covers (not shown) for each bolt.
4. Detail 'A' Silicone Caulk may be applied after installation. Consult with Manufacturer to determine the suitability of the caulk to be applied.

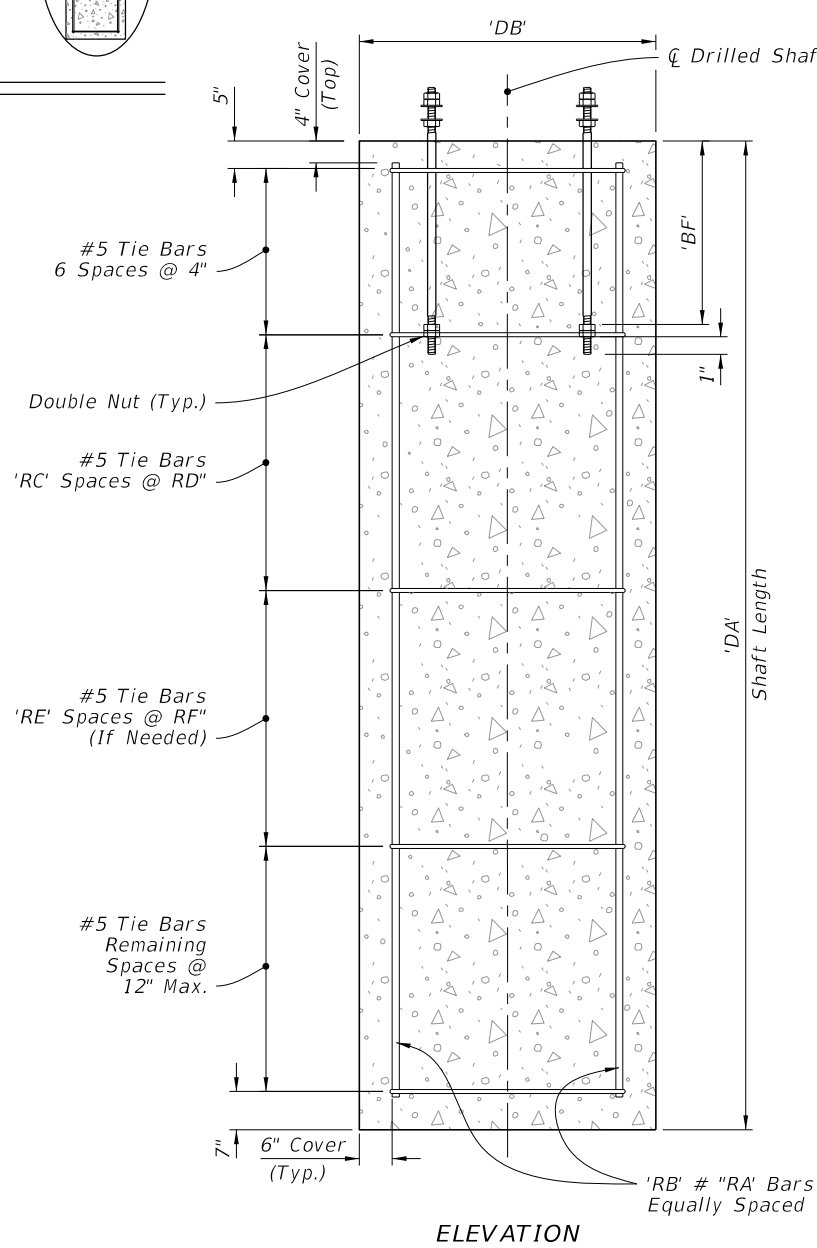

FOUNDATION

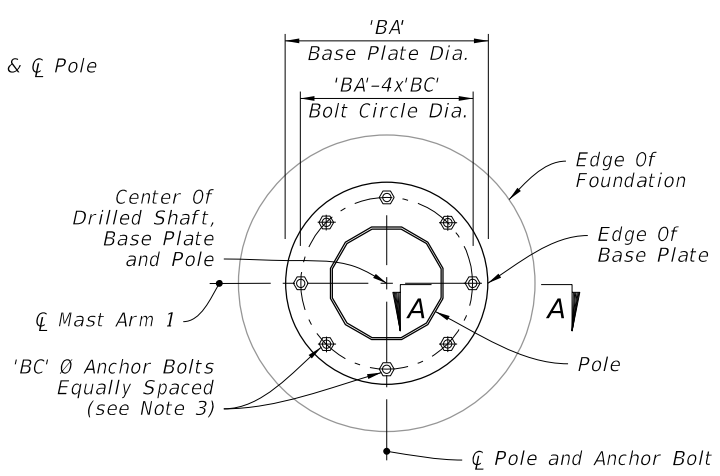
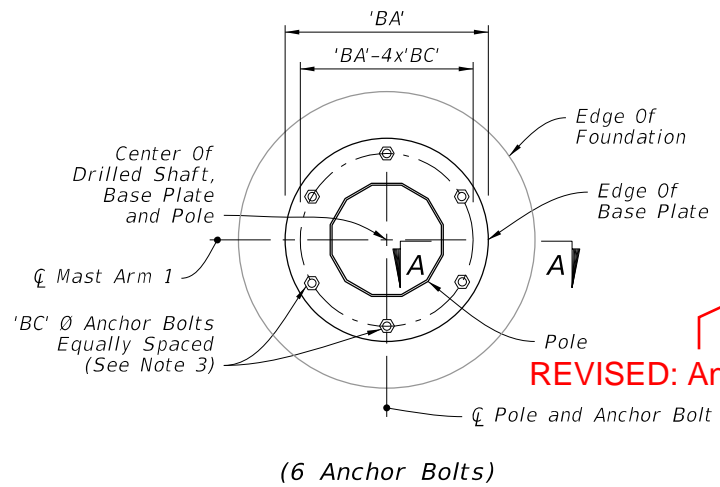

PLAN

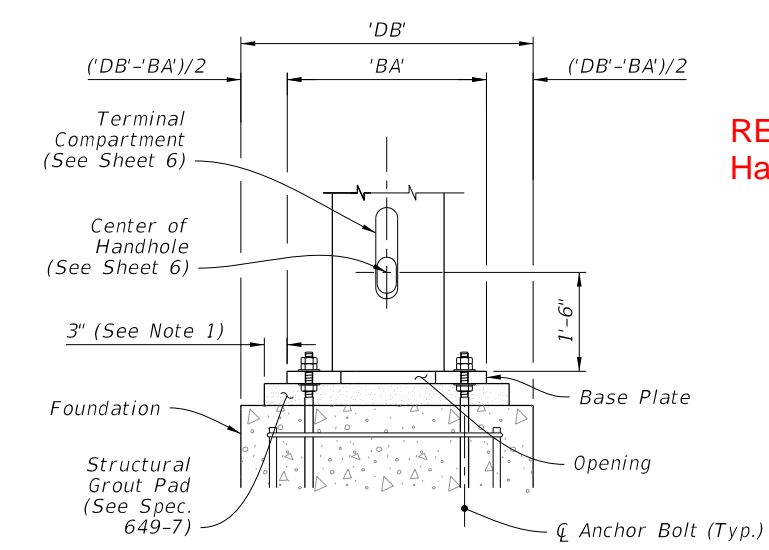

BASE PLATE CONNECTION

REVISED: Retainer Nut (See Note 3)

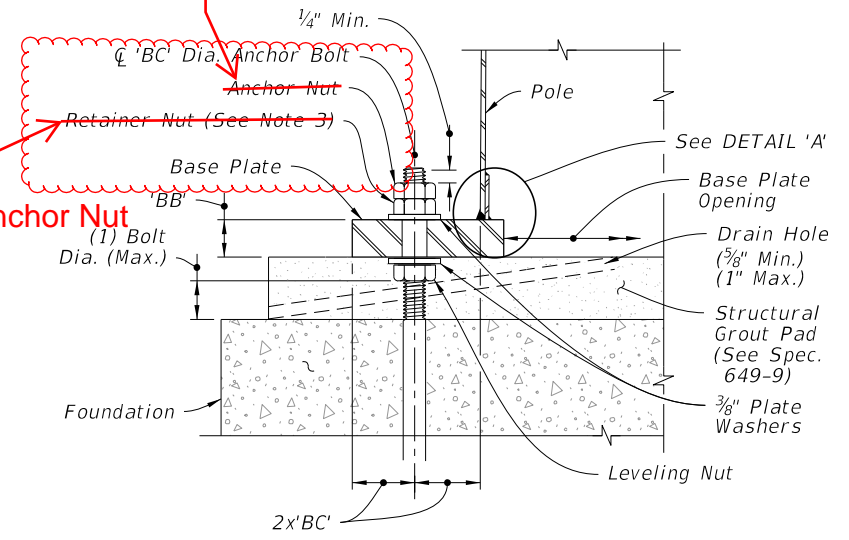

SECTION A-A

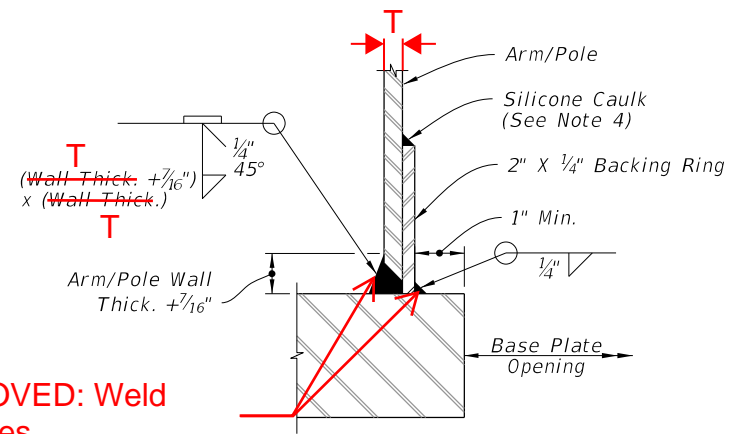

REMOVED: Weld Hatches

JOINT WELD DETAIL

DETAIL 'A'

FOUNDATION AND BASE PLATE DETAILS

10/3/2023 2:25:51 PM

LAST REVISION	DESCRIPTION:
11/01/23	11/01/24



FY 2024-25  
STANDARD PLANS

MAST ARM ASSEMBLIES

INDEX	SHEET
649-031	2 of 6

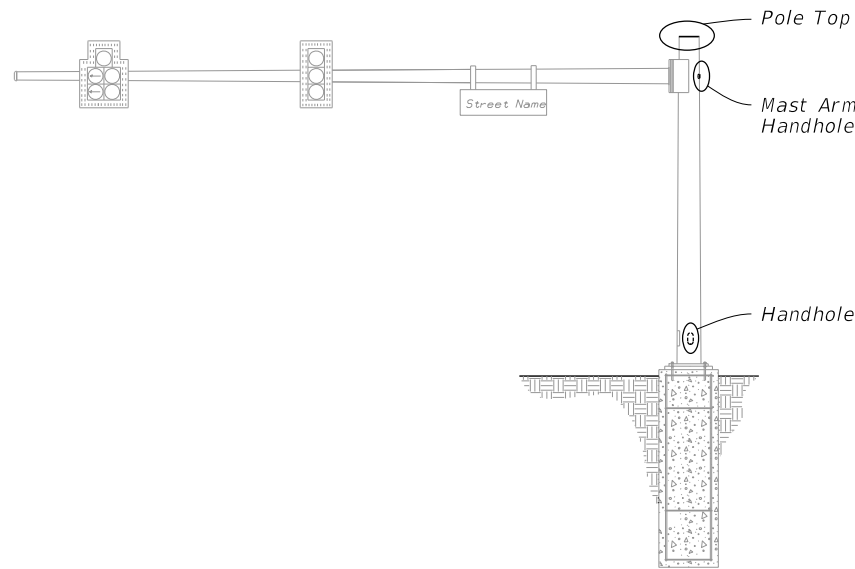

**NOTES:**

1. Handhole covers may be omitted when Terminal Compartment is provided.
2. See Mast Arm Tabulation sheet to see if Terminal Compartment is required and for locations.
3. Terminal Compartment Frame Height 2'-0" minimum to 2'-6" maximum. Align bottom of Terminal Compartment a minimum of 1" below the bottom of the Handhole Frame.
4. Any combination of Option 'a' or 'b' may be used, provided both lifting and wiring is accommodated. Cap may be flat plate or domed cap with set screws.
5. An alternate terminal compartment frame detail is allowed where the compartment frame is of constant depth and cuts into the pole at the frame top and bottom but lays flush with the pole on the frame sides. The frame is then welded to the pole using fillet welds all around the outside.

**MAST ARM ASSEMBLY**

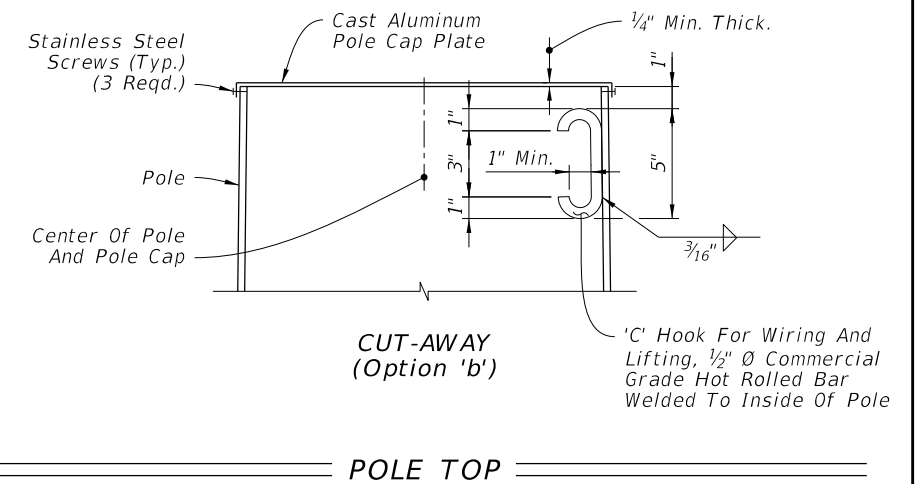
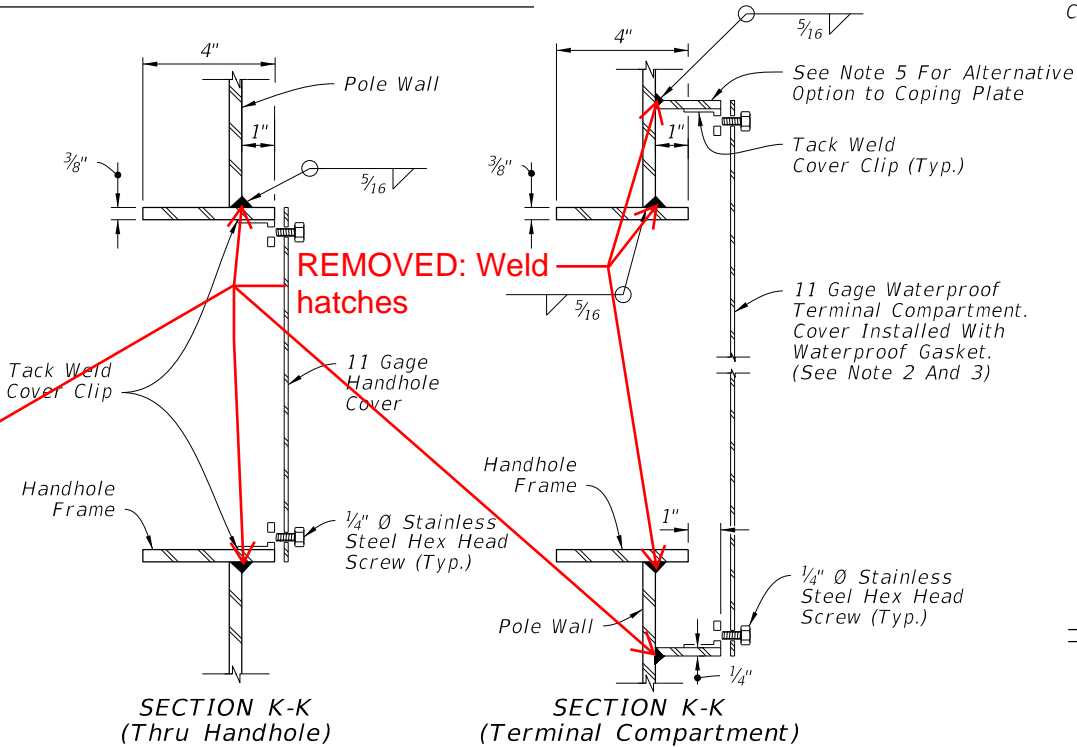
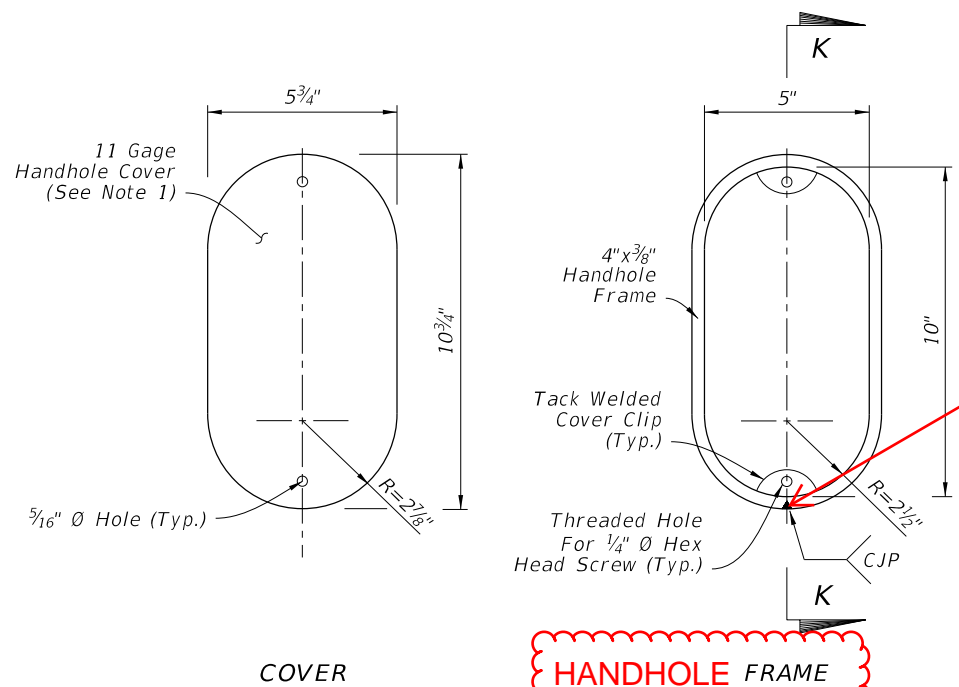
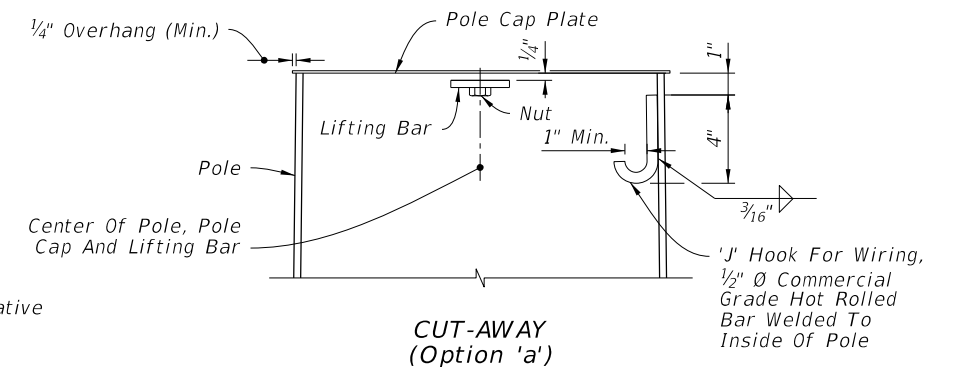
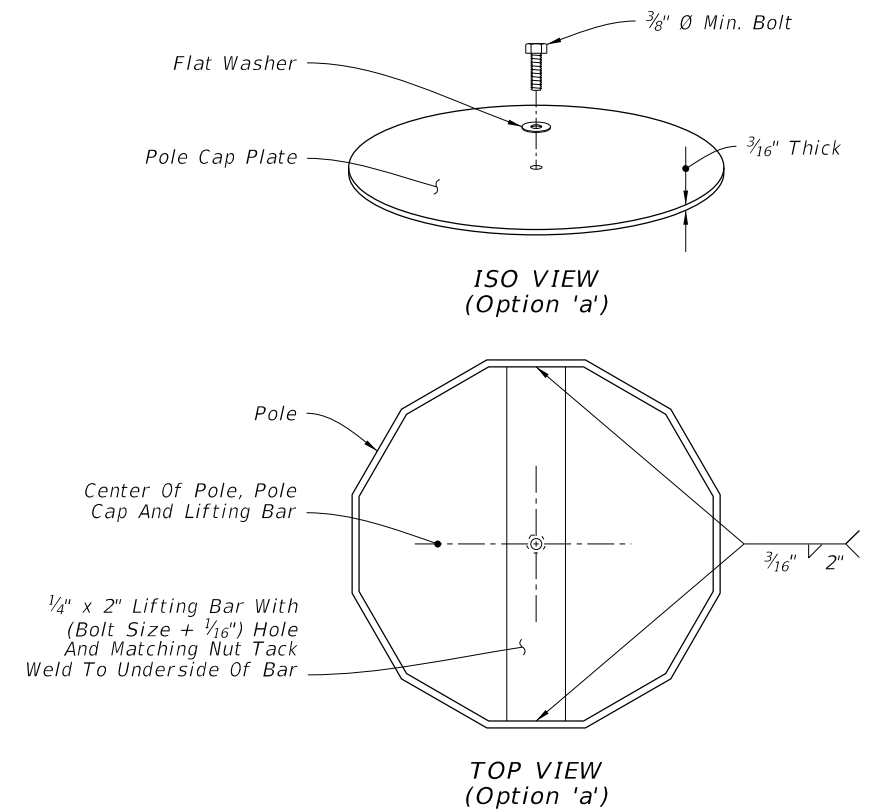
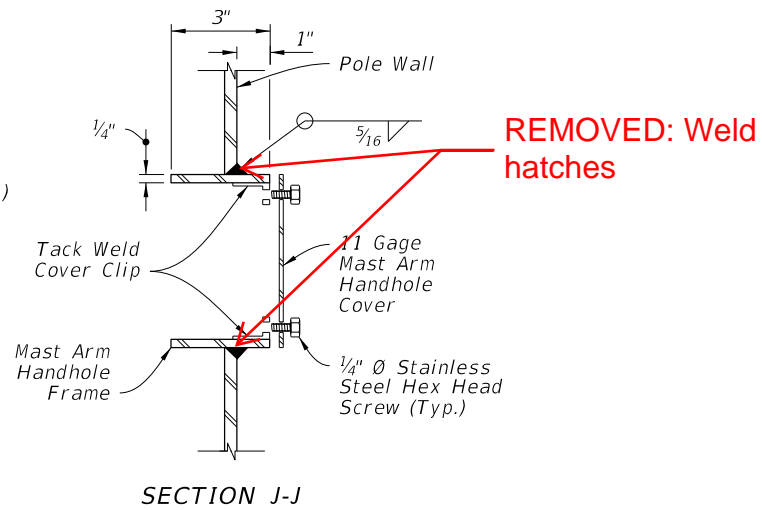
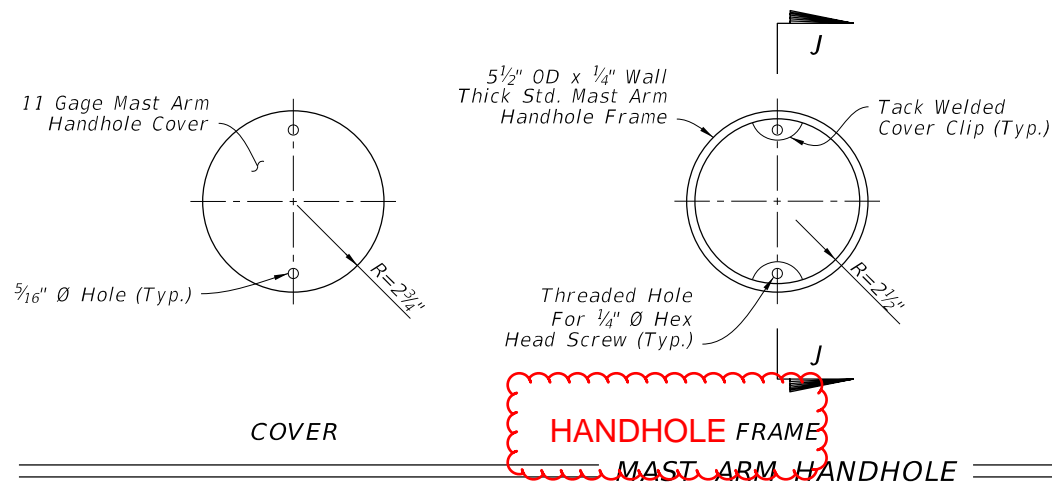

**HANDHOLE AND POLE TOP DETAILS**

10/3/2023 2:26:17 PM

LAST REVISION 11/01/23	DESCRIPTION:
---------------------------	--------------



FY 2024-25  
STANDARD PLANS

MAST ARM ASSEMBLIES

INDEX  
649-031

SHEET  
6 of 6

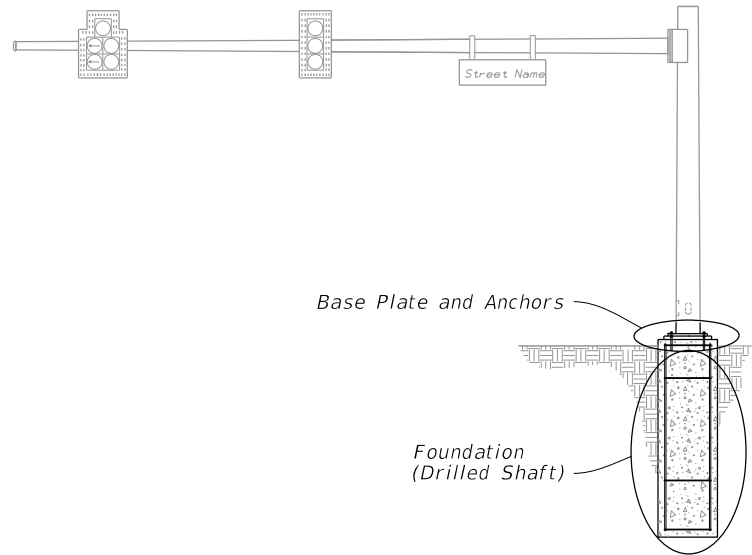

MAST ARM ASSEMBLY

NOTES:

1. The Structural Grout Pad diameter may be reduced where the footprint of the Grout Pad does not provide adequate clearance for the sidewalk and/or accessibility considerations.
2. See Index 649-030 and the plans for actual quantity of bolts in the Base Plate Connection.
3. The retainer nut shown in Section A-A may be half-height. Provide individual nut covers (not shown) for each bolt.
4. Detail 'A' Silicone Caulk may be applied after installation. Consult with Manufacturer to determine the suitability of the caulk to be applied.

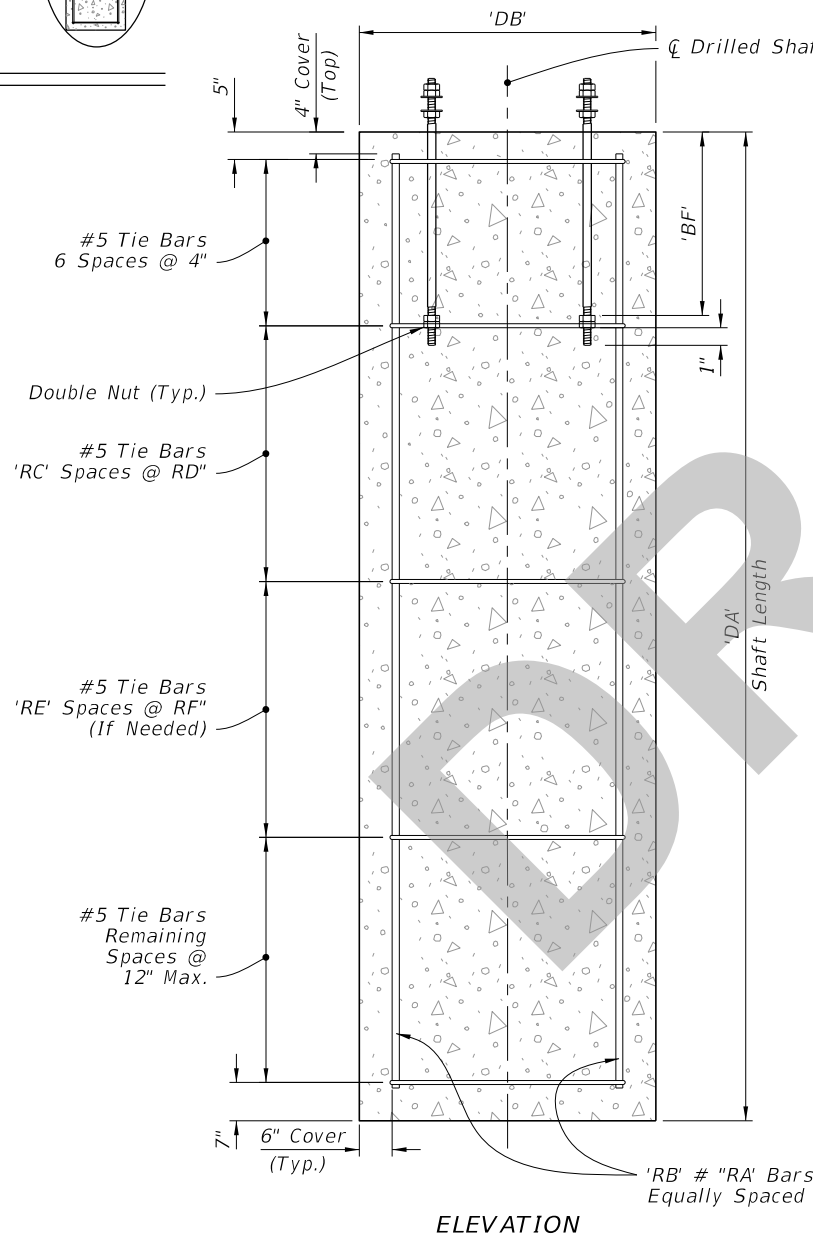

FOUNDATION

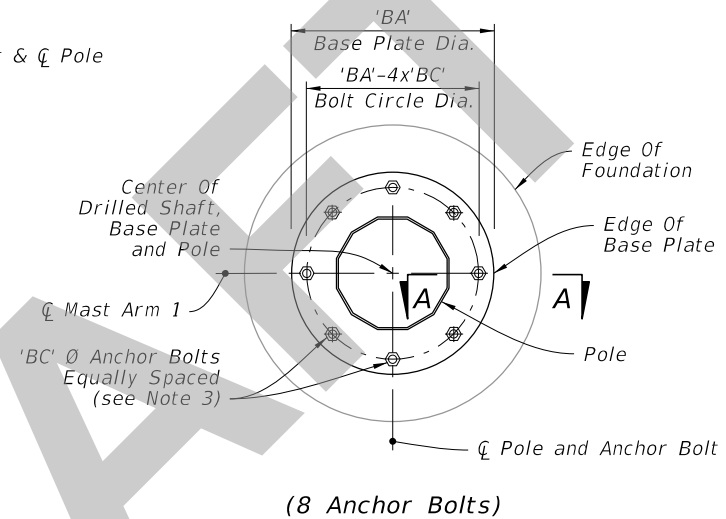
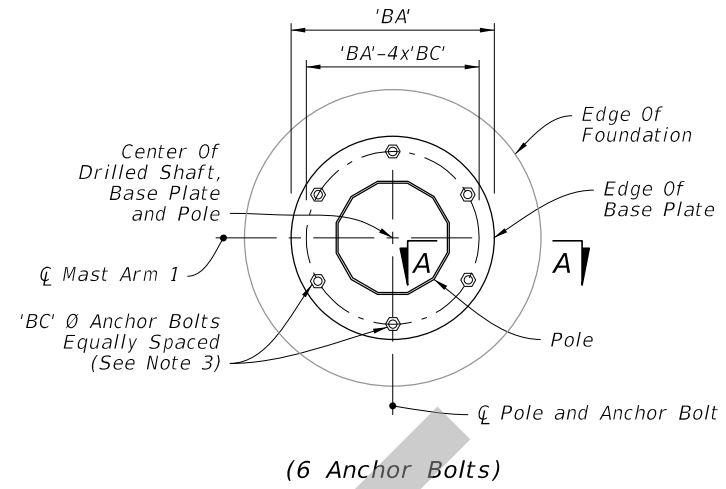

PLAN

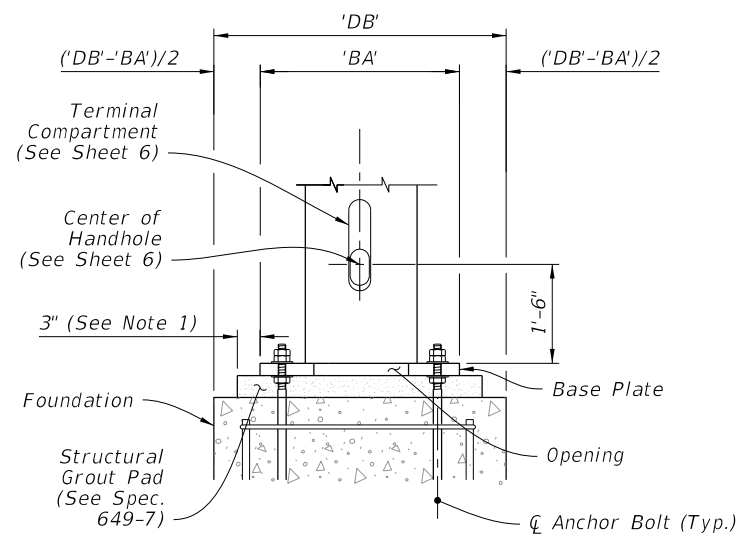

ELEVATION (Back Face Shown)

BASE PLATE CONNECTION

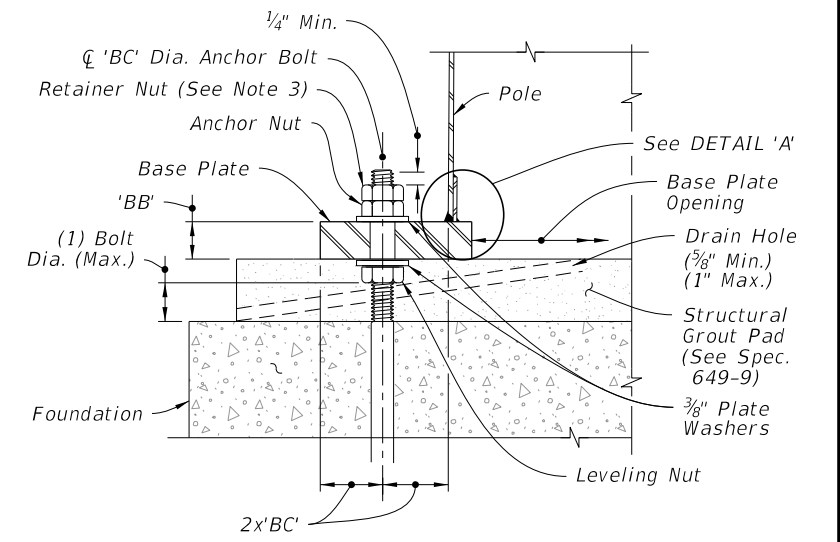

SECTION A-A

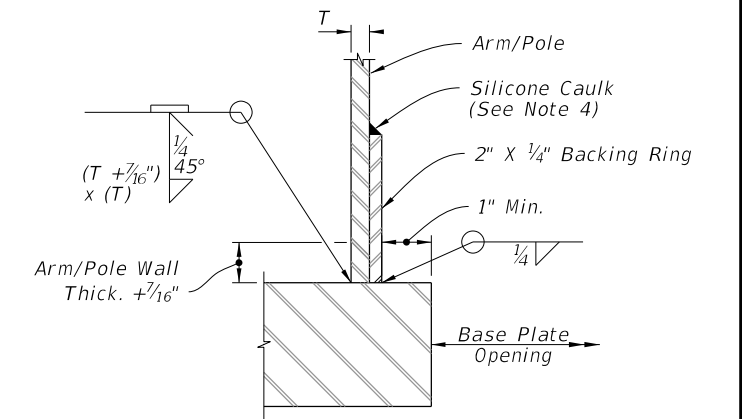

JOINT WELD DETAIL

DETAIL 'A'

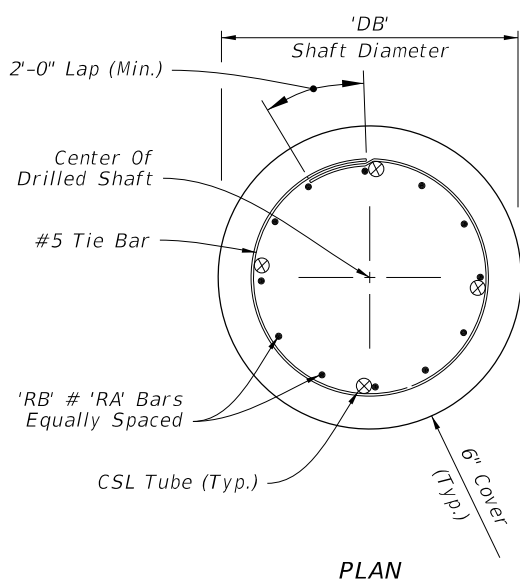

PLAN

FOUNDATION AND BASE PLATE DETAILS

6/10/2024 10:21:51 AM

LAST REVISION 11/01/24	DESCRIPTION:		FY 2025-26 STANDARD PLANS	MAST ARM ASSEMBLIES	INDEX	SHEET
			649-031		2 of 6	

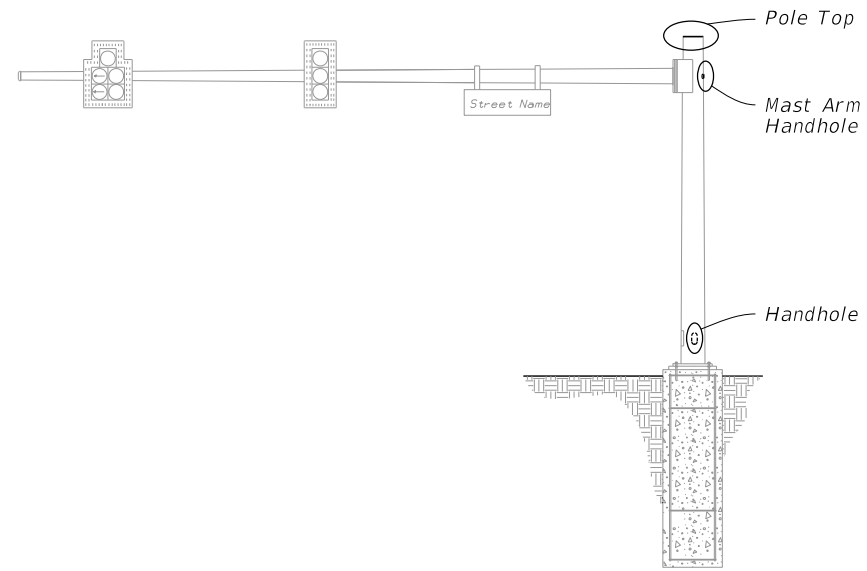

MAST ARM ASSEMBLY

**NOTES:**

1. Handhole covers may be omitted when Terminal Compartment is provided.
2. See Mast Arm Tabulation sheet to see if Terminal Compartment is required and for locations.
3. Terminal Compartment Frame Height 2'-0" minimum to 2'-6" maximum. Align bottom of Terminal Compartment a minimum of 1" below the bottom of the Handhole Frame.
4. Any combination of Option 'a' or 'b' may be used, provided both lifting and wiring is accommodated. Cap may be flat plate or domed cap with set screws.
5. An alternate terminal compartment frame detail is allowed where the compartment frame is of constant depth and cuts into the pole at the frame top and bottom but lays flush with the pole on the frame sides. The frame is then welded to the pole using fillet welds all around the outside.

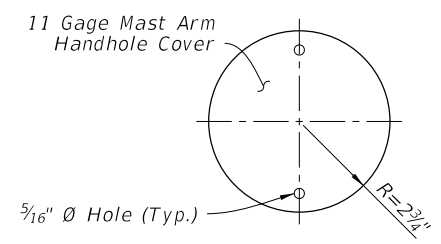

COVER

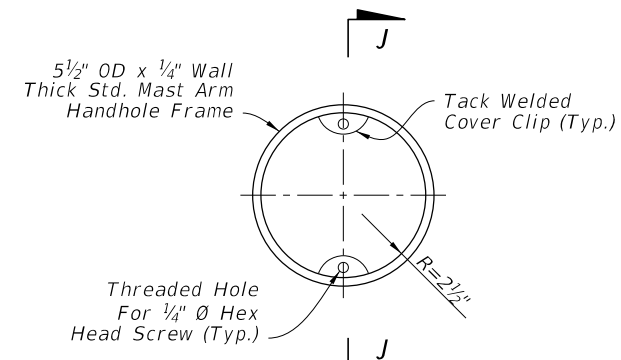

HANDHOLE FRAME

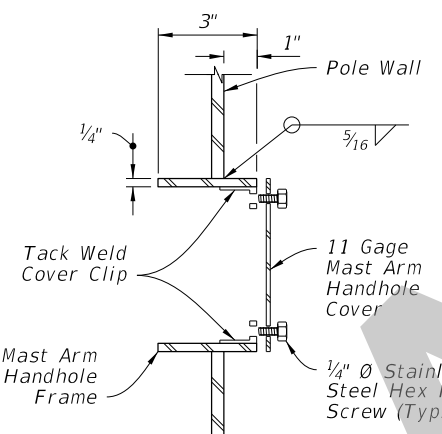

SECTION J-J

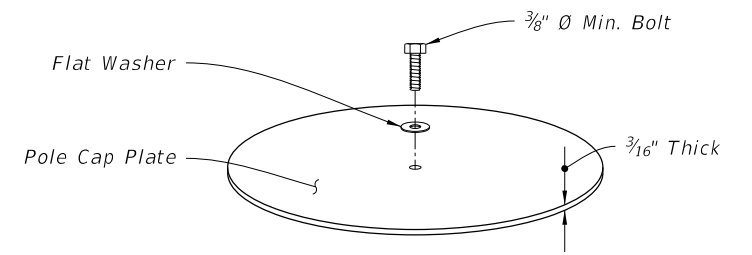

ISO VIEW (Option 'a')

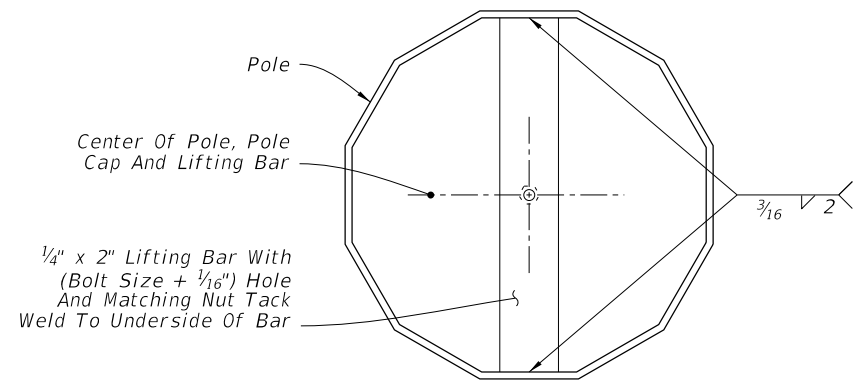

TOP VIEW (Option 'a')

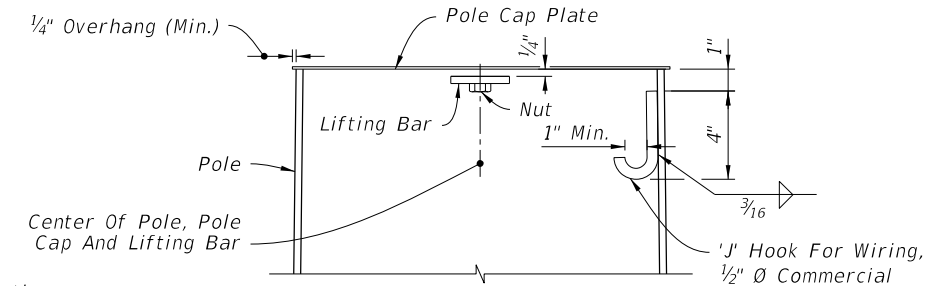

CUT-AWAY (Option 'a')

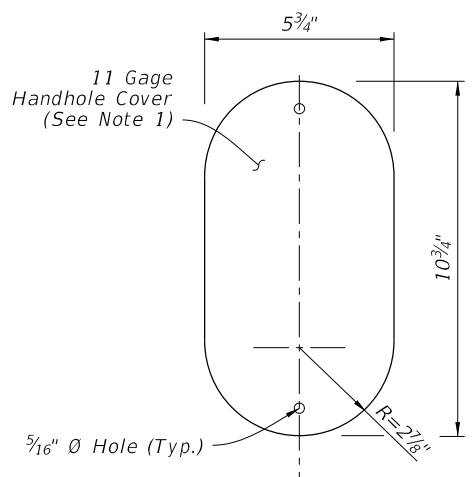

COVER

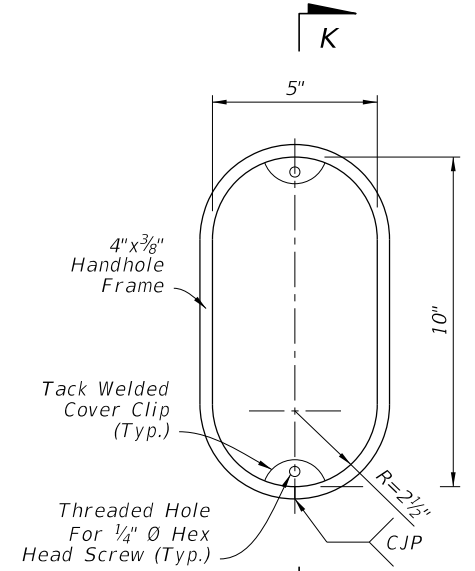

HANDHOLE FRAME

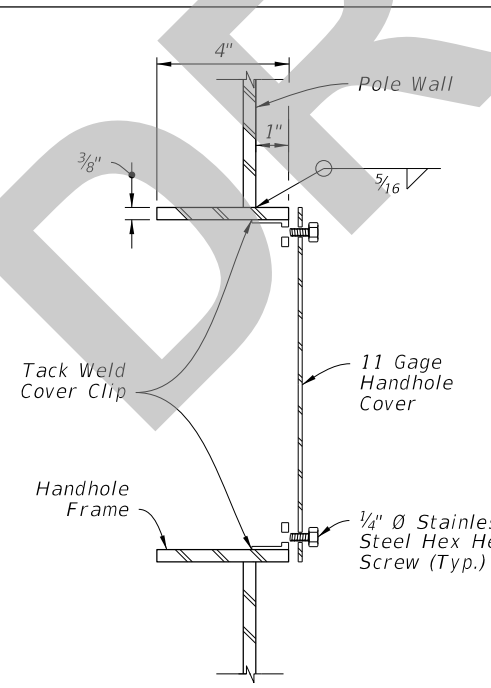

SECTION K-K (Thru Handhole)

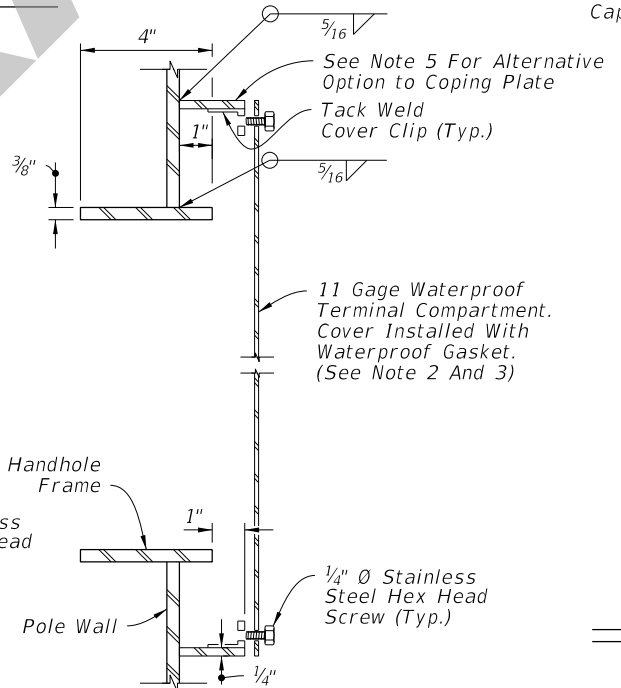

SECTION K-K (Terminal Compartment)

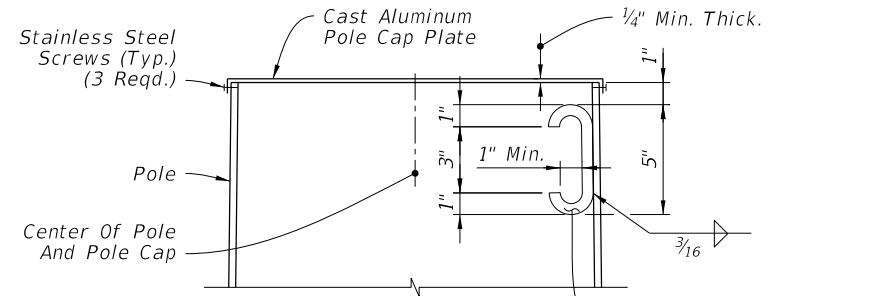

CUT-AWAY (Option 'b')

POLE TOP

HANDHOLE AND POLE TOP DETAILS

6/10/2024 10:21:57 AM

LAST REVISION 11/01/23	DESCRIPTION:		FY 2025-26 STANDARD PLANS	MAST ARM ASSEMBLIES	INDEX	SHEET
					649-031	6 of 6