

# Origination Form

## Proposed Revisions to a Standard Plans Index

<b>Originator:</b>	Turley, Joshua	<b>Index Number:</b>	649-020
<b>Date:</b>	4/17/2024	<b>Sheet Number(s):</b>	3 and 4
<b>E-mail:</b>	Joshua.Turley@dot.state.fl.us	<b>Index Title:</b>	STEEL CCTV POLE

### Summary of the changes:

Sheet 3: Section A-A -- Corrected the label order of the anchor bolt nuts; SECTION B-B -- Modified wall thickness from text to symbol. DETAIL A -- Removed weld hatches and modified weld symbol.  
 Sheet 4: FRAME DETAIL -- Modified weld detailing and modified title; SECTION C-C -- Modified weld detailing; Updated callouts and added dimensions to Rod and Eye Bolt Options.

### Commentary/Background:

Sheet 3: Anchor nut labels were adjusted to correspond correctly with upcoming associated Spec change being drafted for Section 649; We corrected weld detailing for clarity and brevity.  
 Sheet 4: We corrected weld detailing to conform with accepted convention.

Other Affected Documents/Offices	Person Contacted	Affected (Yes/No)
Other Standard Plans		No
FDOT Design Manual		No
Standard Specifications		No
Basis of Estimates Manual		No
Approved Product List		No
Construction Office		No
Maintenance Office		No

### Implementation

["FY-Standard Plans (Next Release)"]

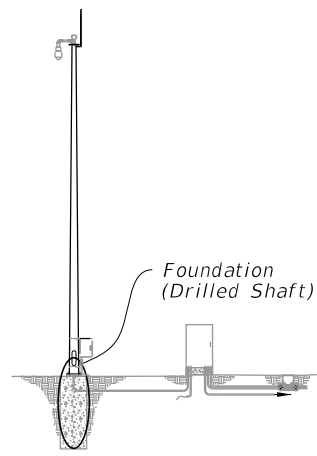

ASSEMBLY

REVISED: Retainer Nut (See Note 2)

REVISED: Anchor Nut

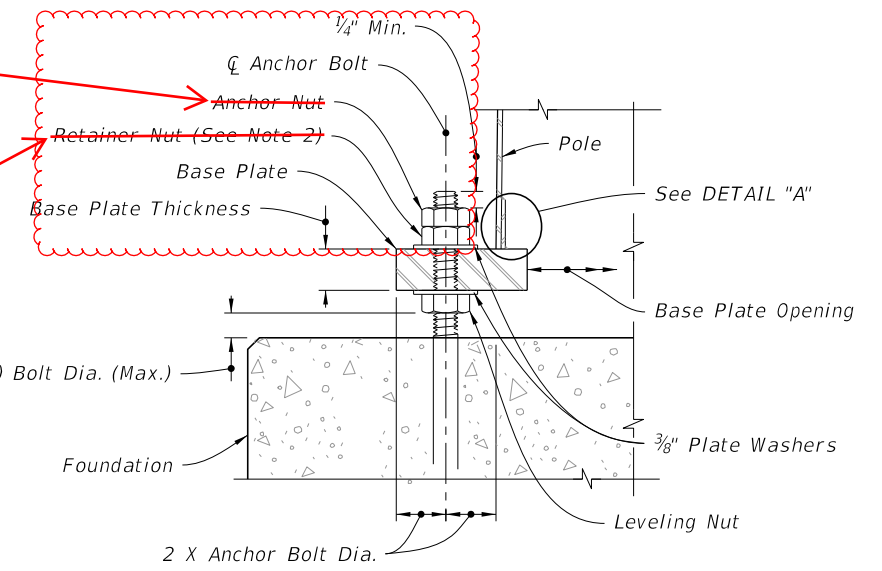

SECTION A-A

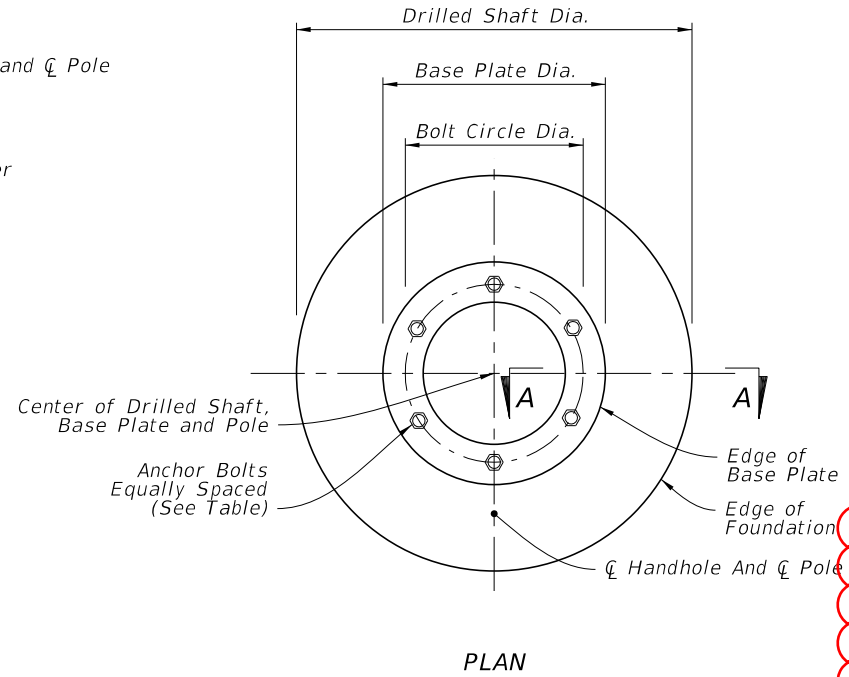

PLAN

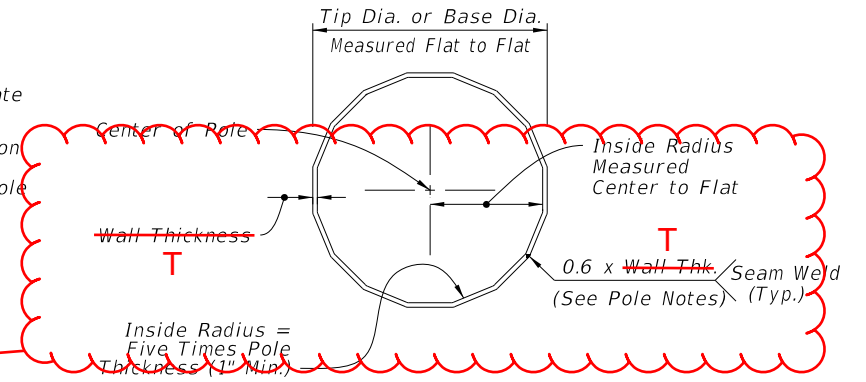

SECTION B-B

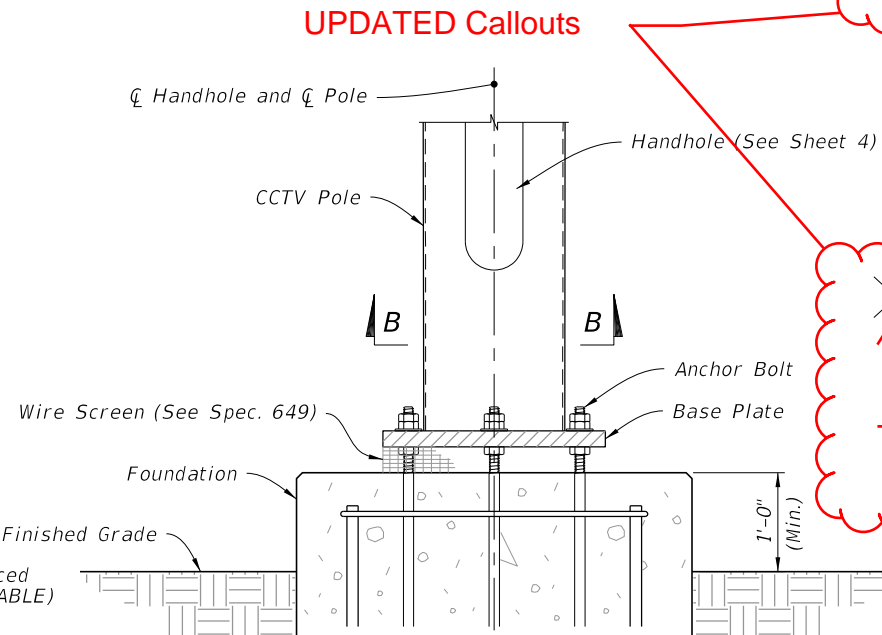

ELEVATION

JOINT WELD DETAIL

- NOTES:
1. Shaft Length is based on 1'-0" height above the finished grade.
  2. Retainer nut may be half-height. Provide individual nut covers (not shown) for each bolt.
  3. Conduit and CSL Tubes not shown for clarity.
  4. Work these details with Data Table on Sheet 2.

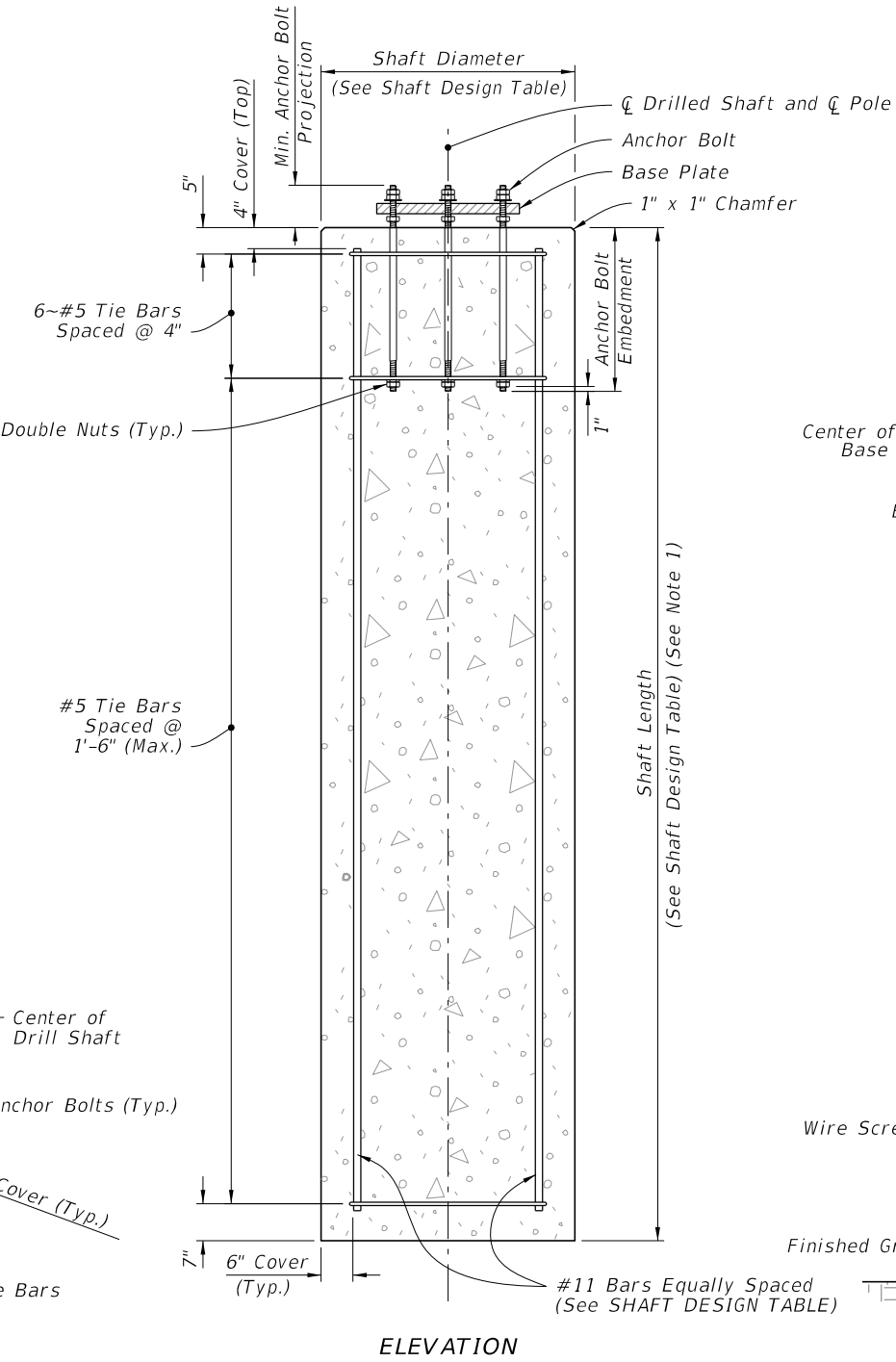

ELEVATION

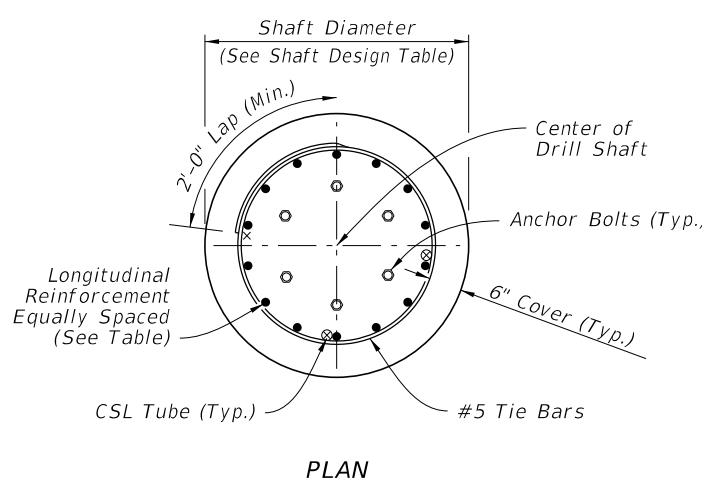

PLAN

FOUNDATION

BASE PLATE

DETAIL "A"

10/3/2023 2:19:54 PM

LAST REVISION <del>11/01/23</del> 11/01/24	REVISION	DESCRIPTION:		FY 2024-25 STANDARD PLANS	STEEL CCTV POLE	INDEX	SHEET
				649-020		3 of 6	

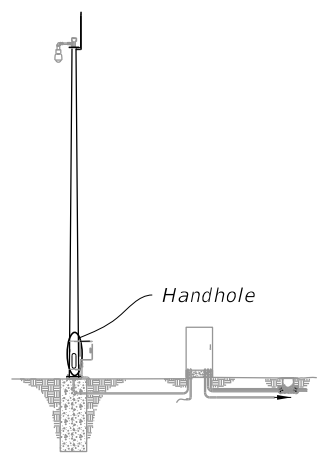

**ASSEMBLY**

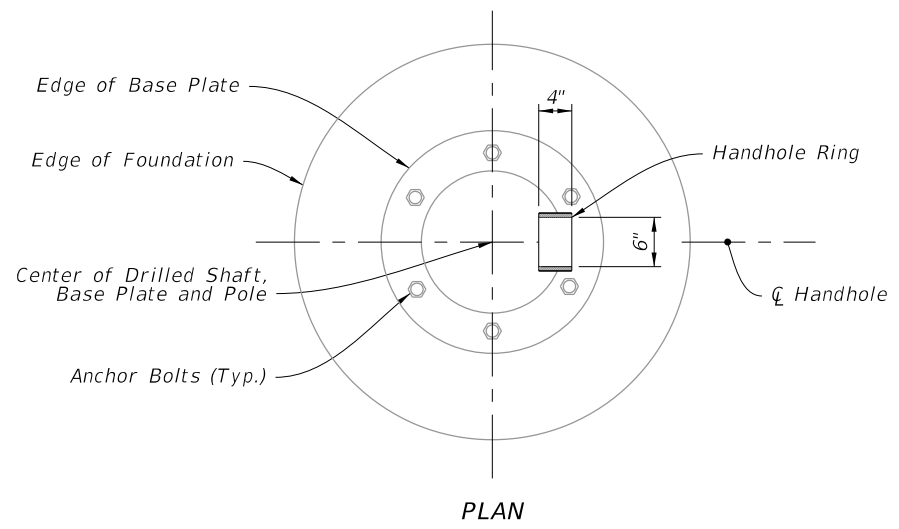

PLAN

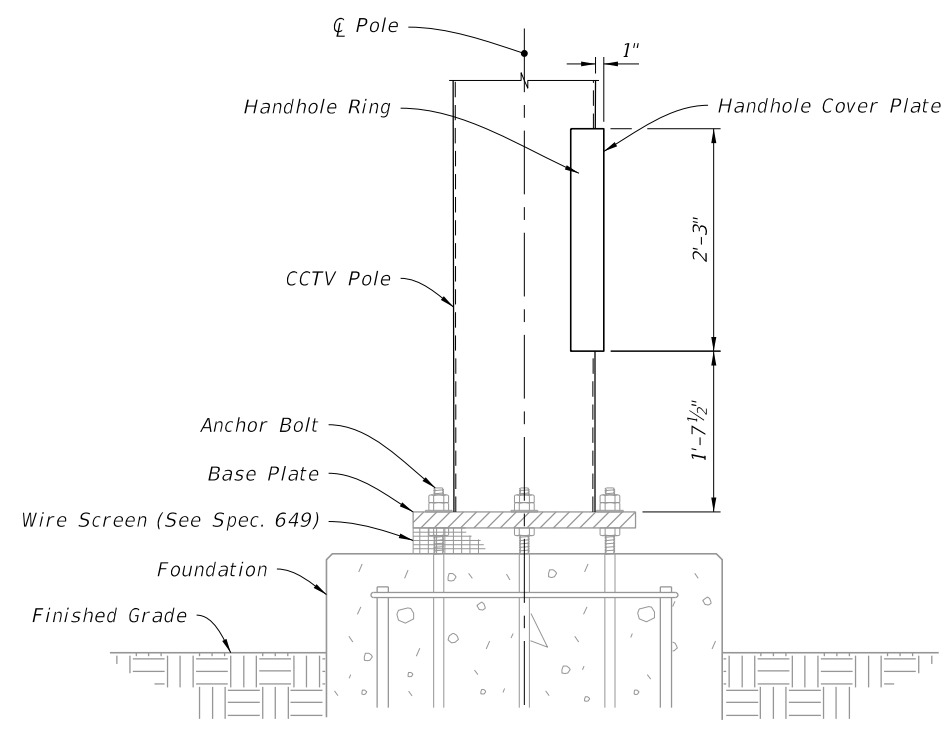

ELEVATION

**HANDHOLE LOCATION**

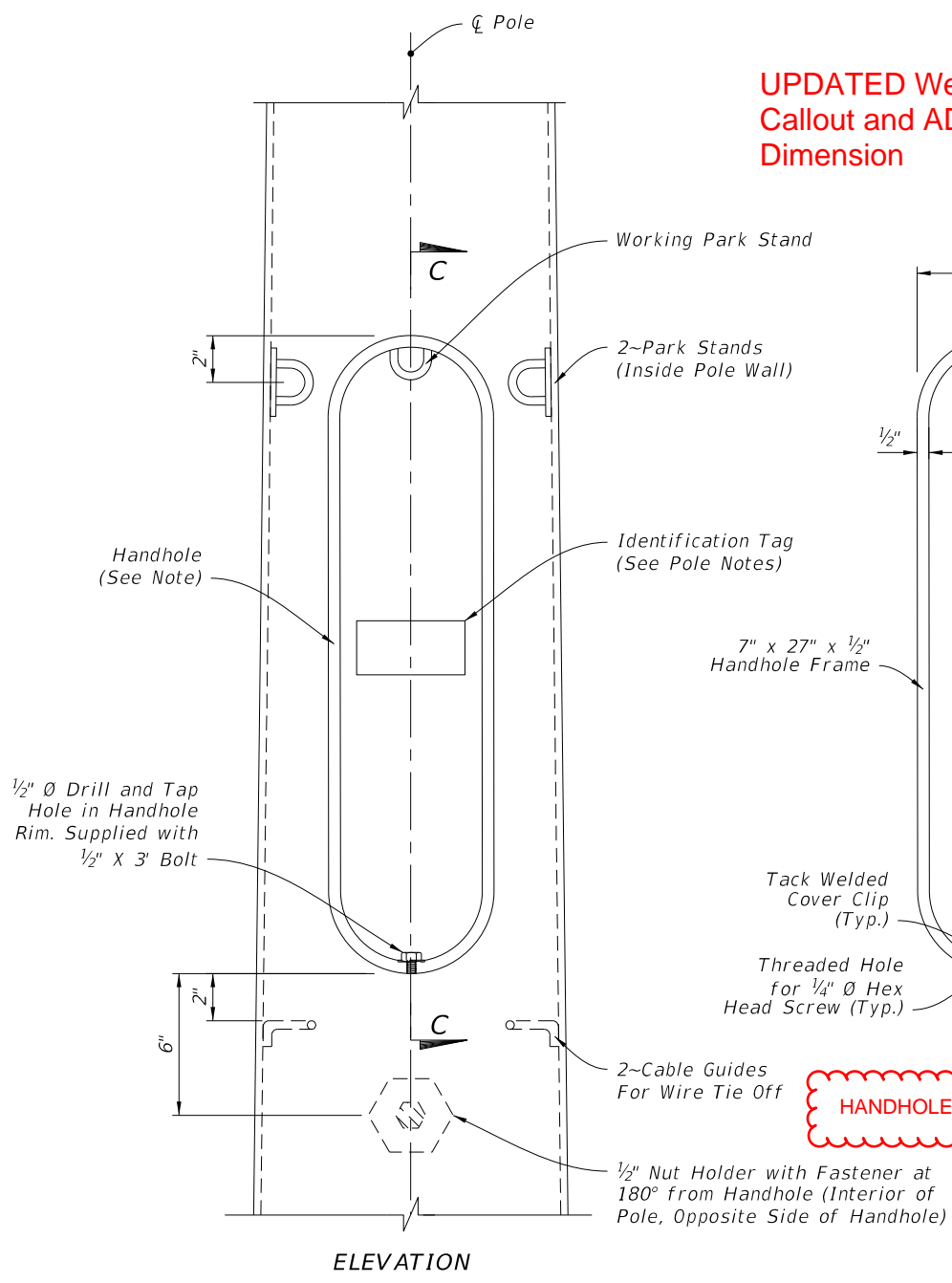

ELEVATION

**HANDHOLE FRAME**

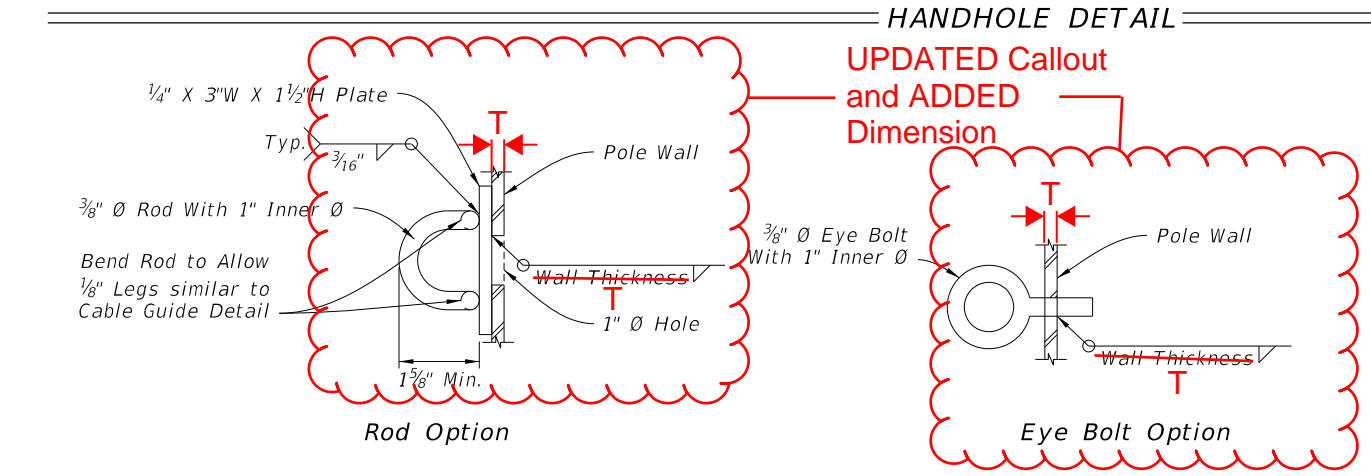

Rod Option

Eye Bolt Option

**PARK STAND DETAILS**

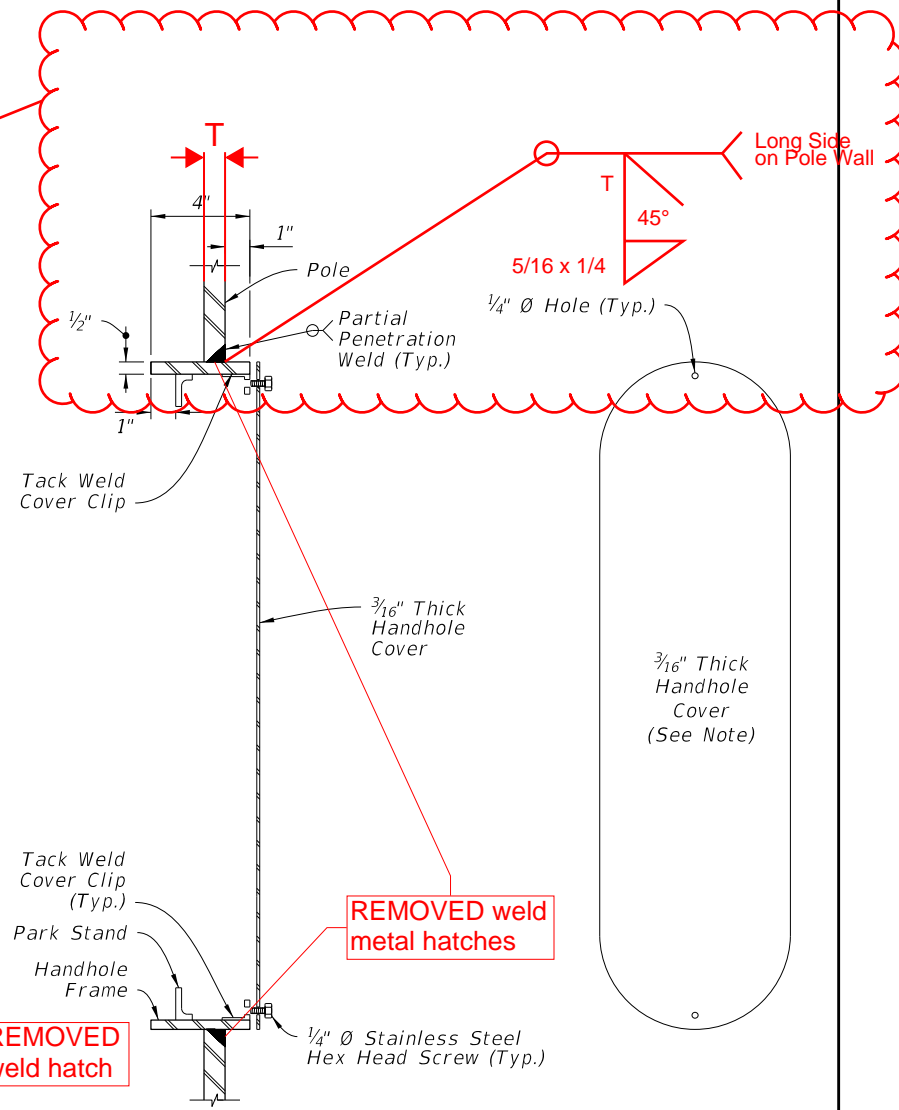

SECTION C-C

COVER PLATE

**NOTE:**

To secure the cover plate, install a steel chain from the cover to the pole or by mounting the cover with hinges and install a pad lock tab.

**CABLE GUIDE DETAIL**

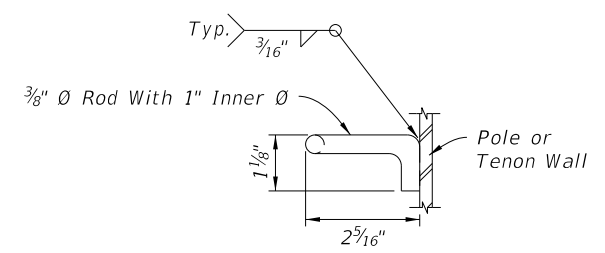

10/3/2023 2:20:01 PM

LAST REVISION	DESCRIPTION:
11/01/23	
11/01/24	



FY 2024-25  
STANDARD PLANS

STEEL CCTV POLE

INDEX  
649-020

SHEET  
4 of 6

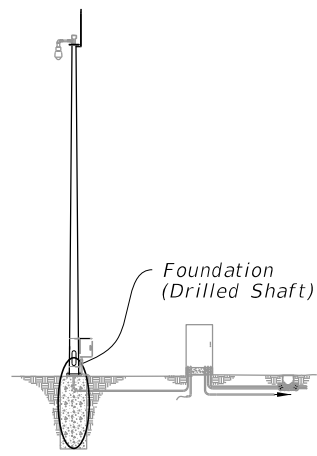

ASSEMBLY

NOTES:

1. Shaft Length is based on 1'-0" height above the finished grade.
2. Retainer nut may be half-height. Provide individual nut covers (not shown) for each bolt.
3. Conduit and CSL Tubes not shown for clarity.
4. Work these details with Data Table on Sheet 2.

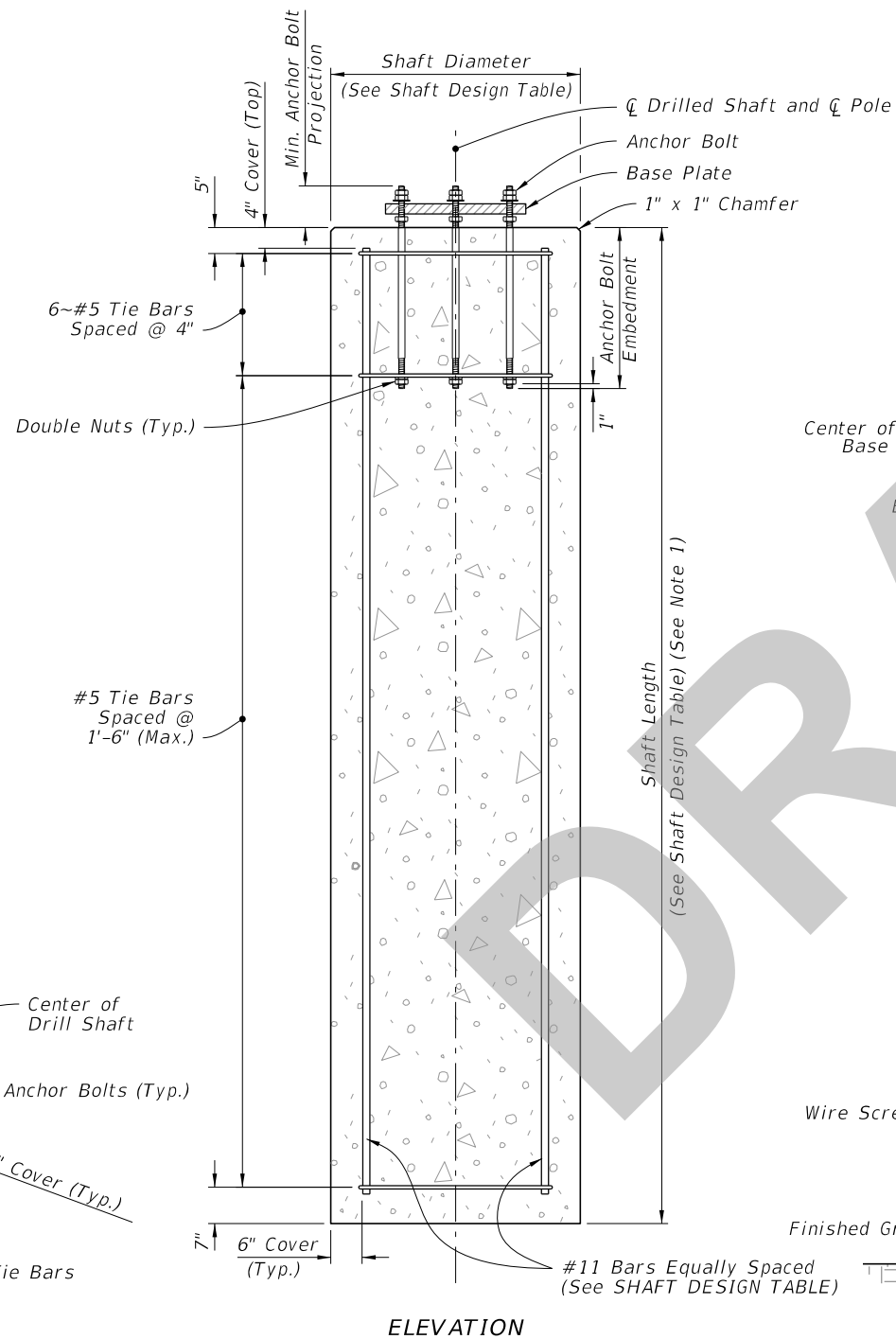

ELEVATION

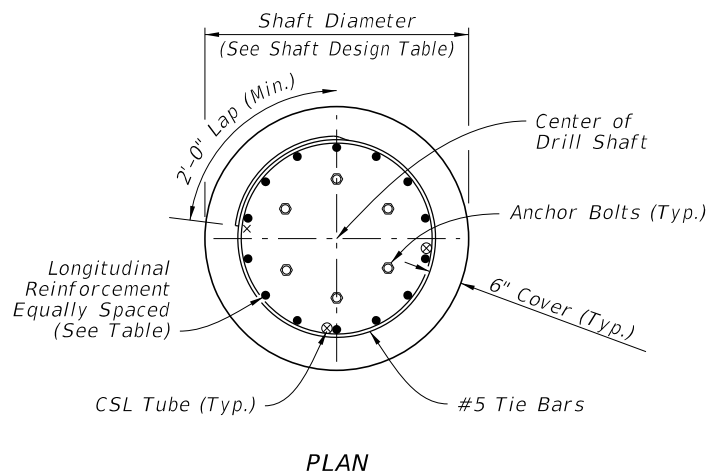

PLAN

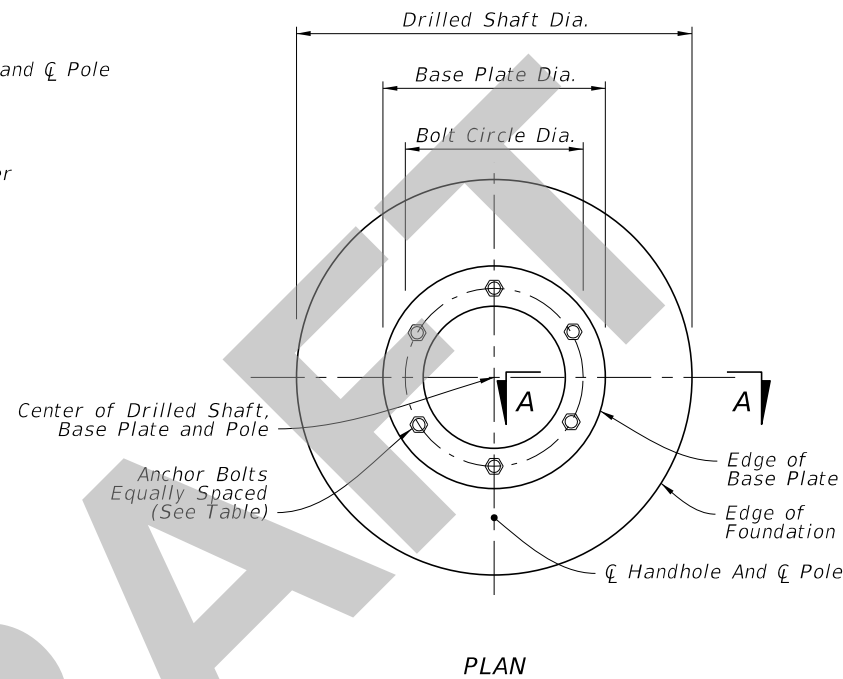

PLAN

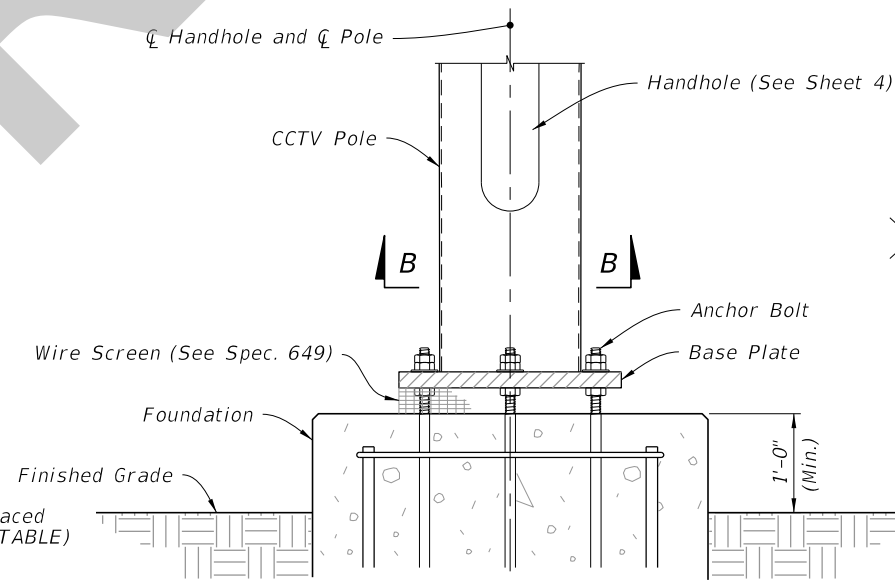

ELEVATION

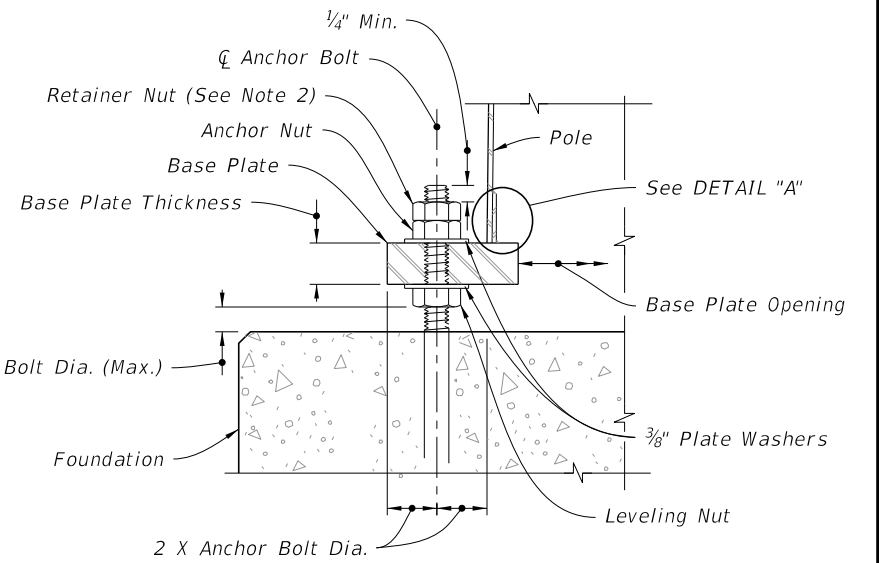

SECTION A-A

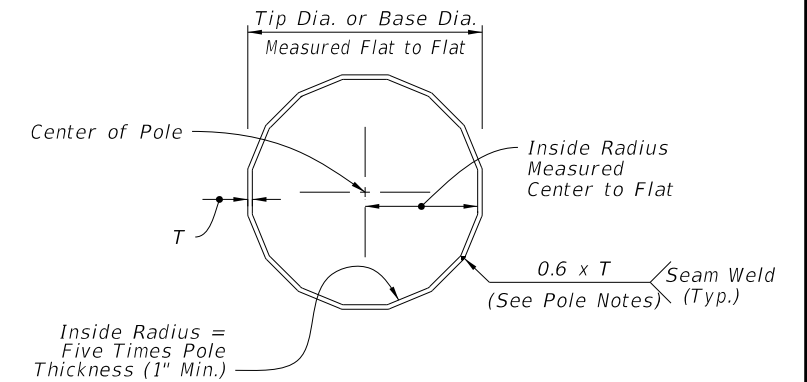

SECTION B-B

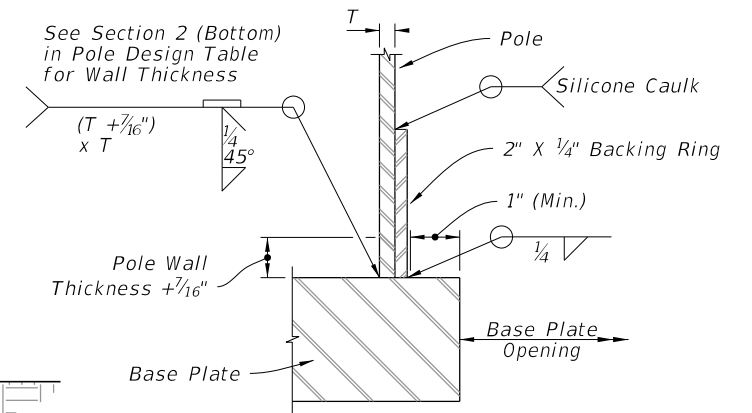

JOINT WELD DETAIL

FOUNDATION

BASE PLATE

DETAIL "A"

6/10/2024 10:17:44 AM

LAST REVISION 11/01/24	DESCRIPTION:
---------------------------	--------------



FY 2025-26  
STANDARD PLANS

STEEL CCTV POLE

INDEX  
649-020

SHEET  
3 of 6

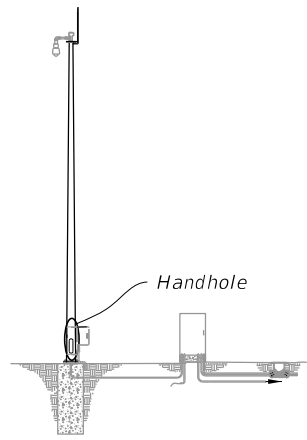

**ASSEMBLY**

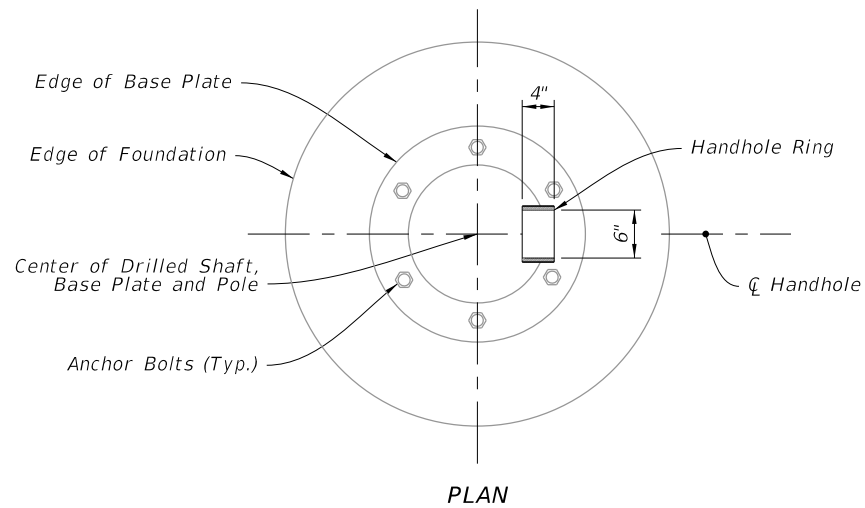

PLAN

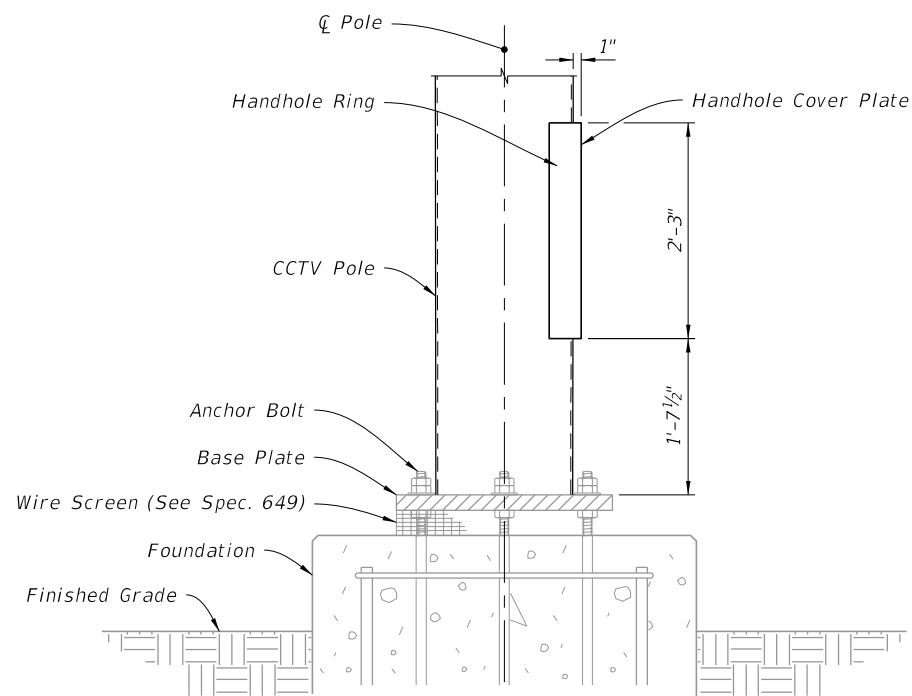

ELEVATION

**HANDHOLE LOCATION**

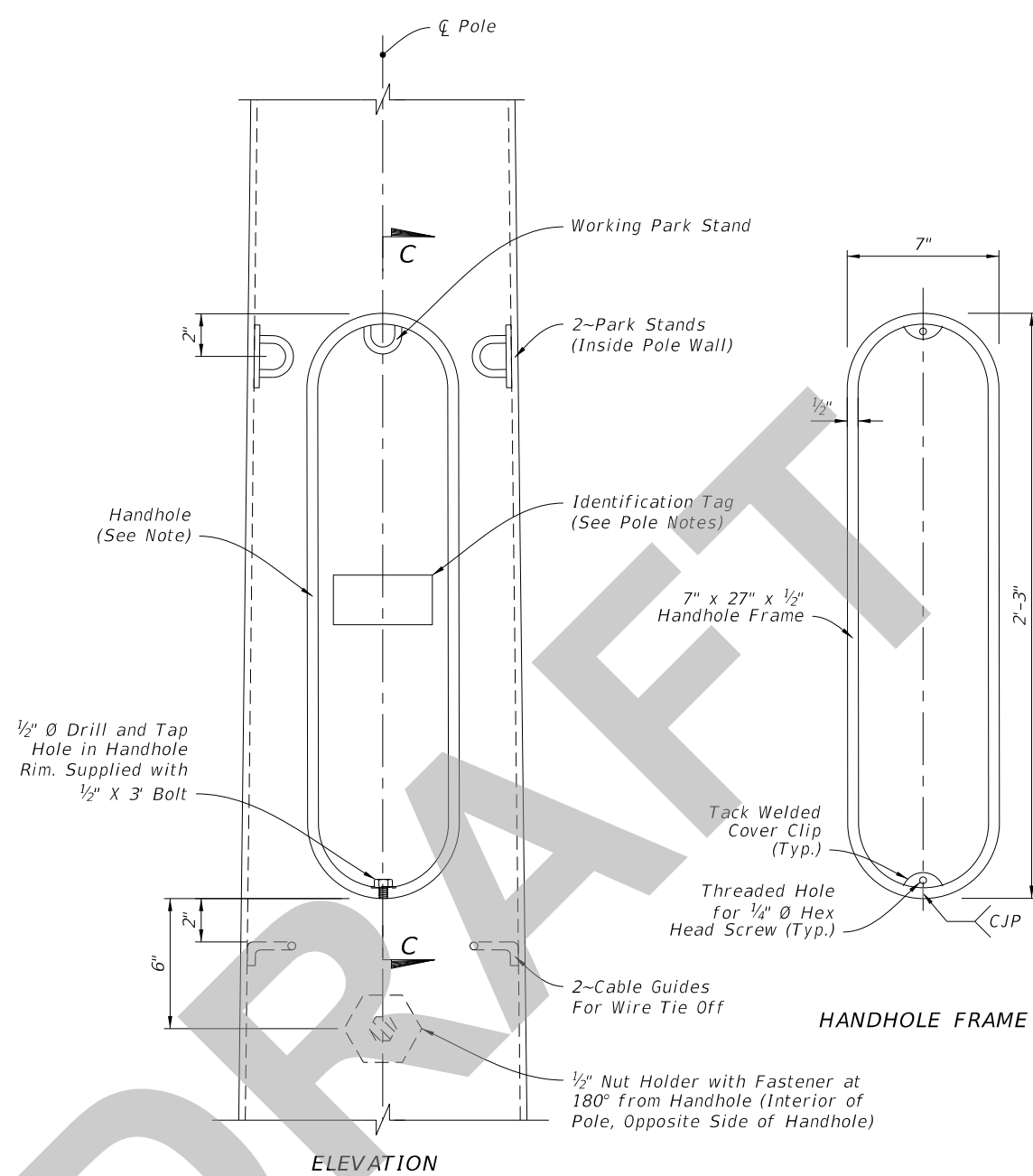

ELEVATION

HANDHOLE FRAME

**HANDHOLE DETAIL**

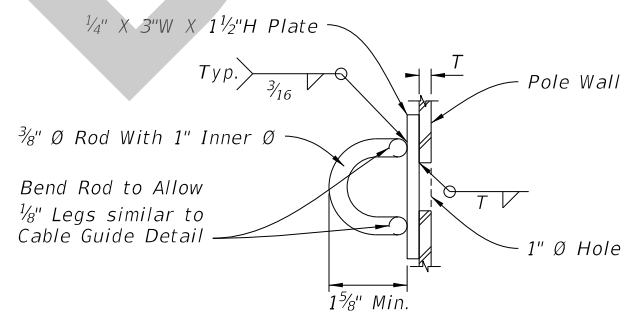

Rod Option

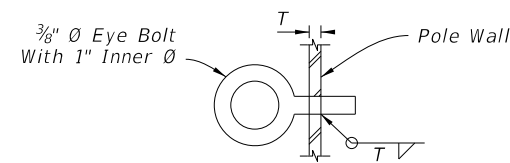

Eye Bolt Option

**PARK STAND DETAILS**

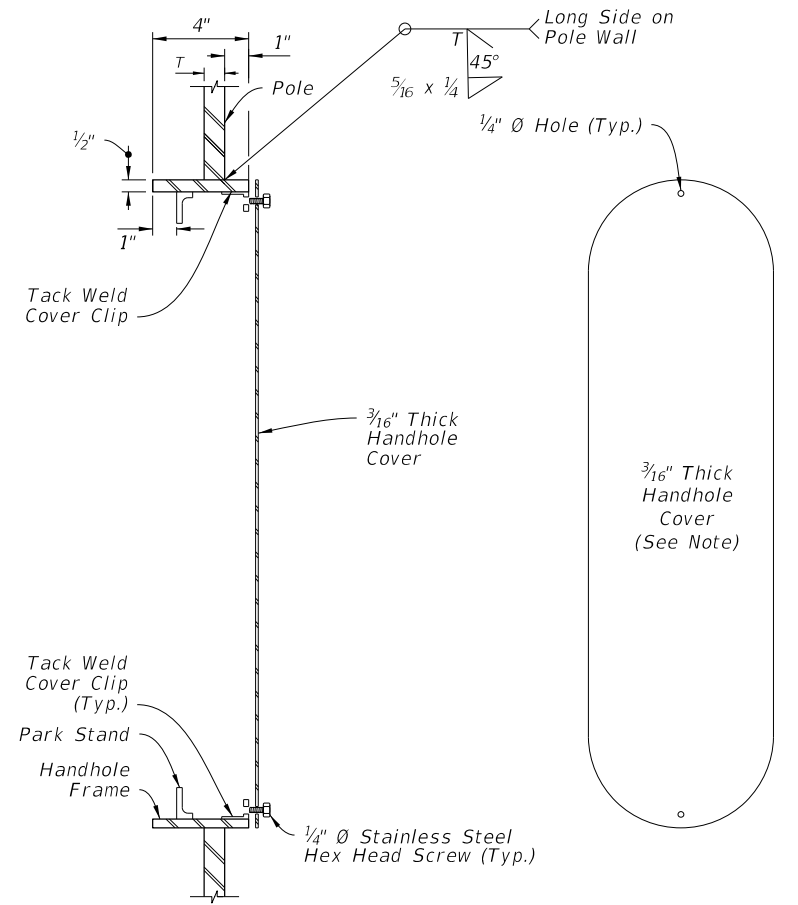

SECTION C-C

COVER PLATE

**NOTE:**

To secure the cover plate, install a steel chain from the cover to the pole or by mounting the cover with hinges and install a pad lock tab.

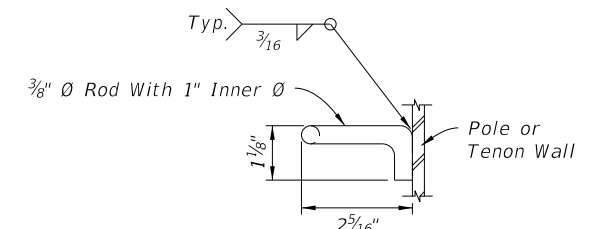

**CABLE GUIDE DETAIL**

10/22/24 5 AM  
6/27/2024

LAST REVISION	DESCRIPTION:
11/01/24	