

Origination Form

Proposed Revisions to a Standard Plans Index

Originator:	Turley, Joshua	Index Number:	550-012
Date:	5/7/2024	Sheet Number(s):	2
E-mail:	Joshua.Turley@dot.state.fl.us	Index Title:	BRIDGE FENCING (ENCLOSED)

Summary of the changes:

Sheet 2: Added shim info to the TABLE OF POST ATTACHMENT COMPONENTS

Commentary/Background:

We needed to add some limiting parameters to edges shims so that they get installed correctly.

Other Affected Documents/Offices	Person Contacted	Affected (Yes/No)
Other Standard Plans		No
Florida Design Manual		No
Standard Specifications		No
Basis of Estimates Manual		No
Approved Product List		No
Construction Office		No
Maintenance Office		No

Implementation

["FY-Standard Plans (Next Release)"]

TABLE OF CHAIN LINK FENCE COMPONENTS		
COMPONENT	ASTM DESIGNATION	COMPONENT INFORMATION
Posts	F1083	Galvanized Steel Pipe - 3" NPS, Schedule 40 Regular Grade
Horizontal Rails and Internal Sleeves	F1083	Galvanized Steel Pipe - 2½" NPS, Schedule 40 Regular Grade
Expansion Rails	F1083	Galvanized Steel Pipe - 2" NPS, Schedule 40 Regular Grade
Chain Link Fabric (2" mesh with knuckled bottom selvages)	A392	Zinc Coated Steel - 9 gage (coated wire diameter), Class 2 Coating
	A491	Aluminum Coated Steel - 9 gage (coated wire diameter)
	F668	Polyvinyl Chloride (PVC) Coated Steel - 9 gage Class 2b Zinc Coated Wire
Tension Wire	A824 & A817	Type II (Zinc Coated Steel Wire) - 7 gage, Class 4 Coating Type I (Aluminum Coated Steel Wire) - 7 gage
Tie Wires	F626	Zinc Coated Steel Wire - 9 gage
Hog Rings	F626	Zinc Coated Steel Wire - 12 gage
Brace Bands	F626	12 gage (Min. thickness) x ¾" (Min. width) Steel Bands (Beveled or Heavy)
Tension Bars	F626	¾" (Min. thickness) x ¾" (Min. width) x Variable Height Steel Bars ~ Height = Tangent or Hoop Length - Barrier or Parapet Height - 2" max.
Tension Bands	F626	14 gage (Min. thickness) x ¾" (Min. width) Steel Bands
Miscellaneous Fence Components	F626	Zinc Coated Steel ~ (includes horizontal rail ends, combination rail ends, boulevard clamps and all other miscellaneous fittings and hardware)
Bolts	A307	¾" Ø x 4¼" Hex Head Bolts for Internal Sleeve connections ¼" Ø x 4¼" Hex Head Bolts for Expansion Rail connections
Nuts	A563	Hex Nuts for Internal Sleeve and Expansion Rail connections
Washers	F436	Flat Washers for Internal Sleeve and Expansion Rail connections

TABLE OF POST ATTACHMENT COMPONENTS		
COMPONENT	ASTM DESIGNATION	COMPONENT INFORMATION
Pipe Clamps	A36 or A709 Grade 36	¼" Steel R
Base Plates	A36 or A709 Grade 36	¾" Steel R
Shim Plates	A36 or A709 Grade 36 or B209 Alloy 6061-T6 or B221 Alloy 6063-T5	Plate thicknesses as required; Holes in shim plates will be ¾" Ø
Spacers	-	Plate thickness varies based on Traffic Railing type. (See Detail "A")
Pipe Clamp Connection	Adhesive Anchor Rods	F1554 Grade 36 Fully threaded Headless Anchor Rods ~ ⅝" Ø x 6" (no spacer) or ⅝" Ø x (6" + spacer thickness)
	C-I-P Anchor Rods	F1554 Grade 36 Hex Head Anchor Rods ~ ⅝" Ø x 6" (no spacer) or ⅝" Ø x (6" + spacer thickness)
Base Plate Connection	Adhesive Anchor Rods	F1554 Grade 36 Fully threaded Headless Anchor Rods ~ ⅞" Ø x 14½"
	C-I-P Anchor Rods	F1554 Grade 36 Hex Head Anchor Rods ~ ⅞" Ø x 14½"
Bolts	A307	¾" Ø x 4¾" Hex Head Bolts for Pipe Clamp Connections to Posts
Nuts	A563	Hex Nuts for Pipe Clamp and Base Plate Connections
Washers	F436	Flat Washers for Pipe Clamp and Base Plate Connections
Bearing Pads (Plain)	-	In accordance with Specification Section 932 for Ancillary Structures

ADDED: For edge shims match the edge length of the base plate with a min. width of 3/4". Apply adhesive bonding material bed of 1-1/2" (Min.) wide

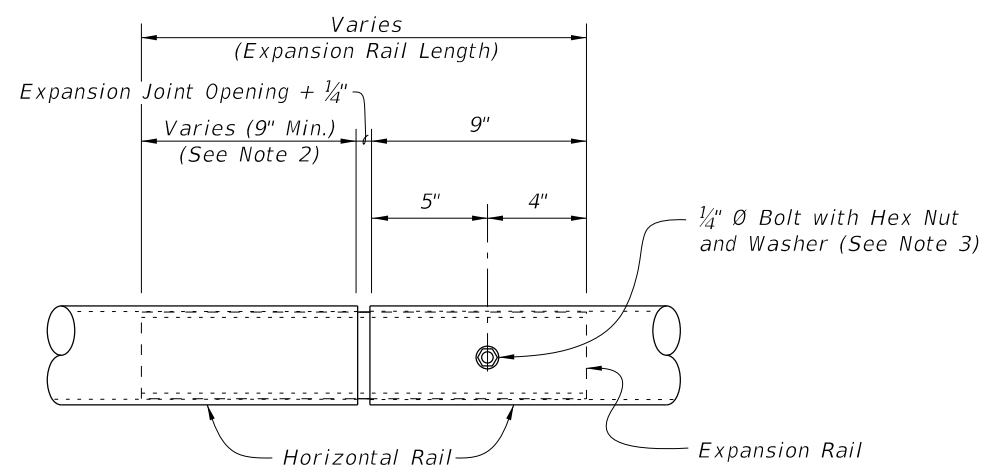

EXPANSION RAIL DETAIL

NOTES:

- Expansion Rails are required at expansion joint locations where the total movement exceeds 1". Install expansion rails midway between the fence posts spanning the expansion joint.
- An Expansion Assembly is required where the total joint movement exceeds 6". Expansion Assembly includes Expansion Rails and two pull posts (see Sheet 3). When the Expansion Joint Opening is greater than 9" add an additional length to the free end of the Expansion Rail equal to the difference between the Expansion Joint Opening and 9".
- Install nut for the expansion rail finger-tight. The nut will fully engage bolts with a minimum of one bolt thread extending beyond the nuts. Distort the first thread on the outside of the nut to prevent loosening.

POST ATTACHMENT NOTES

ANCHOR RODS, NUTS AND WASHERS:

After the nuts have been tightened, distort the Anchor Rod threads to prevent removal of the nuts. Coat distorted threads and exposed trimmed ends of anchors with a galvanizing compound in accordance with Specification Section 562.

COATINGS:

Hot-dip galvanize all Nuts, Washers, Bolts, C-I-P Anchor Rods, Adhesive Anchors and Fence Framework (Posts, Internal Sleeves, Shim Plates, Base Plates, Pipe Clamps and Spacers) in accordance with Specification Section 962. Hot-dip galvanize Fence Framework after fabrication.

ADHESIVE-BONDED ANCHORS AND DOWELS:

Adhesive Bonding Material Systems for Anchors and Dowels will comply with Specification Section 937 and be installed in accordance with Specification Section 416. Cutting of reinforcing steel is permitted for drilled hole installation.

WELDING:

All welding will be in accordance with the American Welding Society Structural Welding Code (Steel) ANSI/AWS D1.1 (current edition). Weld metal will be E60XX or E70XX. Nondestructive testing of welds is not required.

10/16/2023 7:48:59 AM

TABLE OF CHAIN LINK FENCE COMPONENTS		
COMPONENT	ASTM DESIGNATION	COMPONENT INFORMATION
Posts	F1083	Galvanized Steel Pipe - 3" NPS, Schedule 40 Regular Grade
Horizontal Rails and Internal Sleeves	F1083	Galvanized Steel Pipe - 2 1/2" NPS, Schedule 40 Regular Grade
Expansion Rails	F1083	Galvanized Steel Pipe - 2" NPS, Schedule 40 Regular Grade
Chain Link Fabric (2" mesh with knuckled bottom selvages)	A392	Zinc Coated Steel - 9 gage (coated wire diameter), Class 2 Coating
	A491	Aluminum Coated Steel - 9 gage (coated wire diameter)
	F668	Polyvinyl Chloride (PVC) Coated Steel - 9 gage Class 2b Zinc Coated Wire
Tension Wire	A824 & A817	Type II (Zinc Coated Steel Wire) - 7 gage, Class 4 Coating
		Type I (Aluminum Coated Steel Wire) - 7 gage
Tie Wires	F626	Zinc Coated Steel Wire - 9 gage
Hog Rings	F626	Zinc Coated Steel Wire - 12 gage
Brace Bands	F626	12 gage (Min. thickness) x 3/4" (Min. width) Steel Bands (Beveled or Heavy)
Tension Bars	F626	3/16" (Min. thickness) x 3/4" (Min. width) x Variable Height Steel Bars ~ Height = Tangent or Hoop Length - Barrier or Parapet Height - 2" max.
Tension Bands	F626	14 gage (Min. thickness) x 3/4" (Min. width) Steel Bands
Miscellaneous Fence Components	F626	Zinc Coated Steel ~ (includes horizontal rail ends, combination rail ends, boulevard clamps and all other miscellaneous fittings and hardware)
Bolts	A307	3/8" Ø x 4 1/4" Hex Head Bolts for Internal Sleeve connections 1/4" Ø x 4 1/4" Hex Head Bolts for Expansion Rail connections
Nuts	A563	Hex Nuts for Internal Sleeve and Expansion Rail connections
Washers	F436	Flat Washers for Internal Sleeve and Expansion Rail connections

TABLE OF POST ATTACHMENT COMPONENTS		
COMPONENT	ASTM DESIGNATION	COMPONENT INFORMATION
Pipe Clamps	A36 or A709 Grade 36	1/4" Steel R
Base Plates	A36 or A709 Grade 36	3/4" Steel R
Shim Plates	A36 or A709 Grade 36 or B209 Alloy 6061-T6 or B221 Alloy 6063-T5	Plate thicknesses as required. Holes in shim plates will be 3/4" Ø. For edge shims match the edge length of the base plate with a min. width of 3/4". Apply adhesive bonding material bed of 1-1/2" (Min.) wide
Spacers	-	Plate thickness varies based on Traffic Railing type. (See Detail "A")
Pipe Clamp Connection	Adhesive Anchor Rods	F1554 Grade 36 Fully threaded Headless Anchor Rods ~ 5/8" Ø x 6" (no spacer) or 5/8" Ø x (6" + spacer thickness)
	C-I-P Anchor Rods	F1554 Grade 36 Hex Head Anchor Rods ~ 5/8" Ø x 6" (no spacer) or 5/8" Ø x (6" + spacer thickness)
Base Plate Connection	Adhesive Anchor Rods	F1554 Grade 36 Fully threaded Headless Anchor Rods ~ 7/8" Ø x 14 1/2"
	C-I-P Anchor Rods	F1554 Grade 36 Hex Head Anchor Rods ~ 7/8" Ø x 14 1/2"
Bolts	A307	3/8" Ø x 4 3/4" Hex Head Bolts for Pipe Clamp Connections to Posts
Nuts	A563	Hex Nuts for Pipe Clamp and Base Plate Connections
Washers	F436	Flat Washers for Pipe Clamp and Base Plate Connections
Bearing Pads (Plain)	-	In accordance with Specification Section 932 for Ancillary Structures

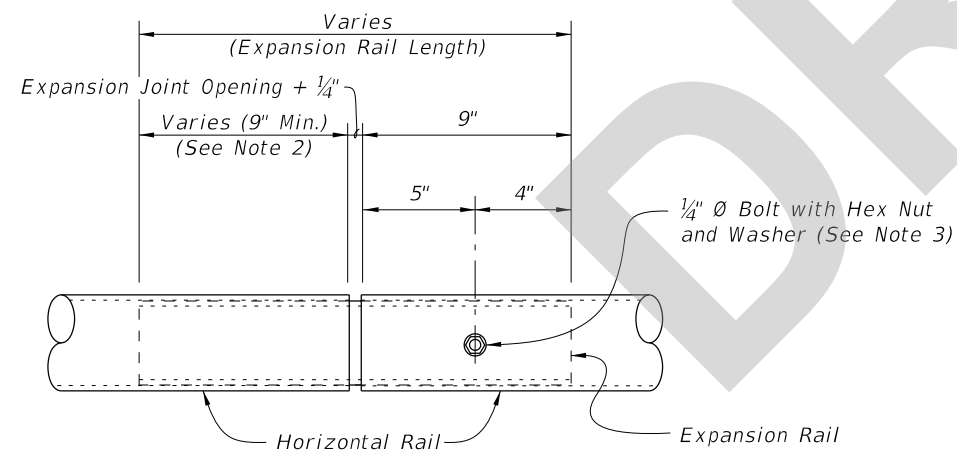

NOTES:

- Expansion Rails are required at expansion joint locations where the total movement exceeds 1". Install expansion rails midway between the fence posts spanning the expansion joint.
- An Expansion Assembly is required where the total joint movement exceeds 6". Expansion Assembly includes Expansion Rails and two pull posts (see Sheet 3). When the Expansion Joint Opening is greater than 9" add an additional length to the free end of the Expansion Rail equal to the difference between the Expansion Joint Opening and 9".
- Install nut for the expansion rail finger-tight. The nut will fully engage bolts with a minimum of one bolt thread extending beyond the nuts. Distort the first thread on the outside of the nut to prevent loosening.

POST ATTACHMENT NOTES

ANCHOR RODS, NUTS AND WASHERS:

After the nuts have been tightened, distort the Anchor Rod threads to prevent removal of the nuts. Coat distorted threads and exposed trimmed ends of anchors with a galvanizing compound in accordance with Specification Section 562.

COATINGS:

Hot-dip galvanize all Nuts, Washers, Bolts, C-I-P Anchor Rods, Adhesive Anchors and Fence Framework (Posts, Internal Sleeves, Shim Plates, Base Plates, Pipe Clamps and Spacers) in accordance with Specification Section 962. Hot-dip galvanize Fence Framework after fabrication.

ADHESIVE-BONDED ANCHORS AND DOWELS:

Adhesive Bonding Material Systems for Anchors and Dowels will comply with Specification Section 937 and be installed in accordance with Specification Section 416. Cutting of reinforcing steel is permitted for drilled hole installation.

WELDING:

All welding will be in accordance with the American Welding Society Structural Welding Code (Steel) ANSI/AWS D1.1 (current edition). Weld metal will be E60XX or E70XX. Nondestructive testing of welds is not required.

4/23/2024 7:52:03 AM