

Origination Form

Proposed Revisions to a Standard Plans Index

Originator:	Turley, Joshua	Index Number:	550-011
Date:	5/7/2024	Sheet Number(s):	3
E-mail:	Joshua.Turley@dot.state.fl.us	Index Title:	BRIDGE FENCING ON PARAPET (CURVED TOP)

Summary of the changes:

Sheet 3: Added shim info to the TABLE OF POST ATTACHMENT COMPONENTS

Commentary/Background:

We needed to add some limiting parameters to edges shims so that they get installed correctly.

Other Affected Documents/Offices	Person Contacted	Affected (Yes/No)
Other Standard Plans		No
FDOT Design Manual		No
Standard Specifications		No
Basis of Estimates Manual		No
Approved Product List		No
Construction Office		No
Maintenance Office		No

Implementation

["FY-Standard Plans (Next Release)"]

TABLE OF POST ATTACHMENT COMPONENTS		
COMPONENT	ASTM DESIGNATION	COMPONENT INFORMATION
Base Plates	A36 or A709 Grade 36	$\frac{3}{4}$ " Steel R
Shim Plates	A36 or A709 Grade 36 or B209 Alloy 6061-T6 or B221 Alloy 6063-T5	Plate thicknesses as required, Holes in shim plates will be $\frac{3}{4}$ " \emptyset
Adhesive Anchor Rods	F1554 Grade 36	Fully threaded Headless Anchor Rods $\sim \frac{7}{8}$ " \emptyset x $14\frac{1}{2}$ "
C-I-P Anchor Rods	F1554 Grade 36	Hex Head Anchor Rods $\sim \frac{7}{8}$ " \emptyset x $14\frac{1}{2}$ "
Nuts	A563	Hex Nuts for Base Plate Connections
Washers	F436	Flat Washers for Base Plate Connections
Bearing Pads (Plain)	-	In accordance with Specification Section 932 for ancillary structures

POST ATTACHMENT NOTES

ANCHOR RODS, NUTS AND WASHERS:

After the nuts have been tightened, distort the Anchor Rod threads to prevent removal of the nuts. Coat distorted threads and exposed trimmed ends of anchors with a galvanizing compound in accordance with Specification Section 562.

COATINGS:

Hot-dip galvanize all Nuts, Washers, Bolts, C-I-P Anchor Rods, Adhesive Anchors and Fence Framework (Posts, Internal Sleeves, Shim Plates and Base Plates) in accordance with Specification Section 962. Hot-dip galvanize Fence Framework after fabrication.

ADHESIVE-BONDED ANCHORS AND DOWELS:

Adhesive Bonding Material Systems for Anchors and Dowels will comply with Specification Section 937 and be installed in accordance with Specification Section 416. Cutting of reinforcing steel is permitted for drilled hole installation.

WELDING:

All welding will be in accordance with the American Welding Society Structural Welding Code (Steel) ANSI/AWS D1.1 (current edition). Weld metal will be E60XX or E70XX. Nondestructive testing of welds is not required.

ADDED NEW NOTE: For edge shims match the edge length of the base plate with a min. width of 3/4". Apply adhesive bonding material bed of 1-1/2" (Min.) wide

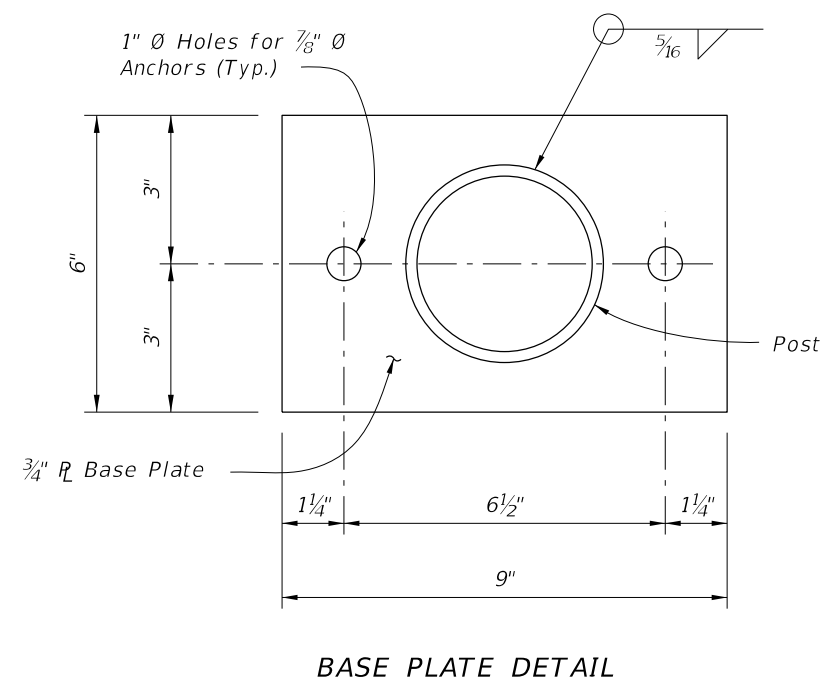
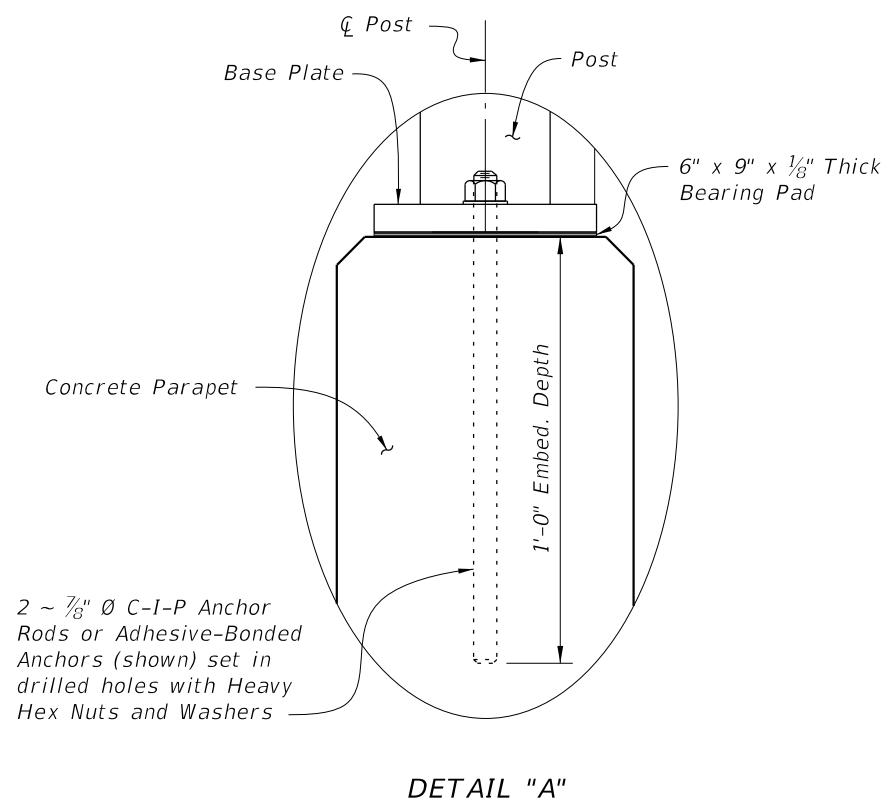

CROSS REFERENCE:
For location of Detail "A" see Sheet 1.

10/16/2023 7:48:15 AM

LAST REVISION 11/01/23	REVISION 11/01/24	DESCRIPTION: 11/01/24		FY 2024-25 STANDARD PLANS	BRIDGE FENCING ON PARAPET (CURVED TOP)	INDEX 550-011	SHEET 3 of 3
--------------------------------------	----------------------	--------------------------	--	------------------------------	--	------------------	-----------------

TABLE OF POST ATTACHMENT COMPONENTS		
COMPONENT	ASTM DESIGNATION	COMPONENT INFORMATION
Base Plates	A36 or A709 Grade 36	$\frac{3}{4}$ " Steel R
Shim Plates	A36 or A709 Grade 36 or B209 Alloy 6061-T6 or B221 Alloy 6063-T5	Plate thicknesses as required. Holes in shim plates will be $\frac{3}{4}$ " \emptyset . For edge shims match the edge length of the base plate with a min. width of $\frac{3}{4}$ ". Apply adhesive bonding material bed of 1-1/2" (Min.) wide
Adhesive Anchor Rods	F1554 Grade 36	Fully threaded Headless Anchor Rods $\sim \frac{7}{8}$ " \emptyset x 14 1/2"
C-I-P Anchor Rods	F1554 Grade 36	Hex Head Anchor Rods $\sim \frac{7}{8}$ " \emptyset x 14 1/2"
Nuts	A563	Hex Nuts for Base Plate Connections
Washers	F436	Flat Washers for Base Plate Connections
Bearing Pads (Plain)	-	In accordance with Specification Section 932 for ancillary structures

POST ATTACHMENT NOTES

ANCHOR RODS, NUTS AND WASHERS:

After the nuts have been tightened, distort the Anchor Rod threads to prevent removal of the nuts. Coat distorted threads and exposed trimmed ends of anchors with a galvanizing compound in accordance with Specification Section 562.

COATINGS:

Hot-dip galvanize all Nuts, Washers, Bolts, C-I-P Anchor Rods, Adhesive Anchors and Fence Framework (Posts, Internal Sleeves, Shim Plates and Base Plates) in accordance with Specification Section 962. Hot-dip galvanize Fence Framework after fabrication.

ADHESIVE-BONDED ANCHORS AND DOWELS:

Adhesive Bonding Material Systems for Anchors and Dowels will comply with Specification Section 937 and be installed in accordance with Specification Section 416. Cutting of reinforcing steel is permitted for drilled hole installation.

WELDING:

All welding will be in accordance with the American Welding Society Structural Welding Code (Steel) ANSI/AWS D1.1 (current edition). Weld metal will be E60XX or E70XX. Nondestructive testing of welds is not required.

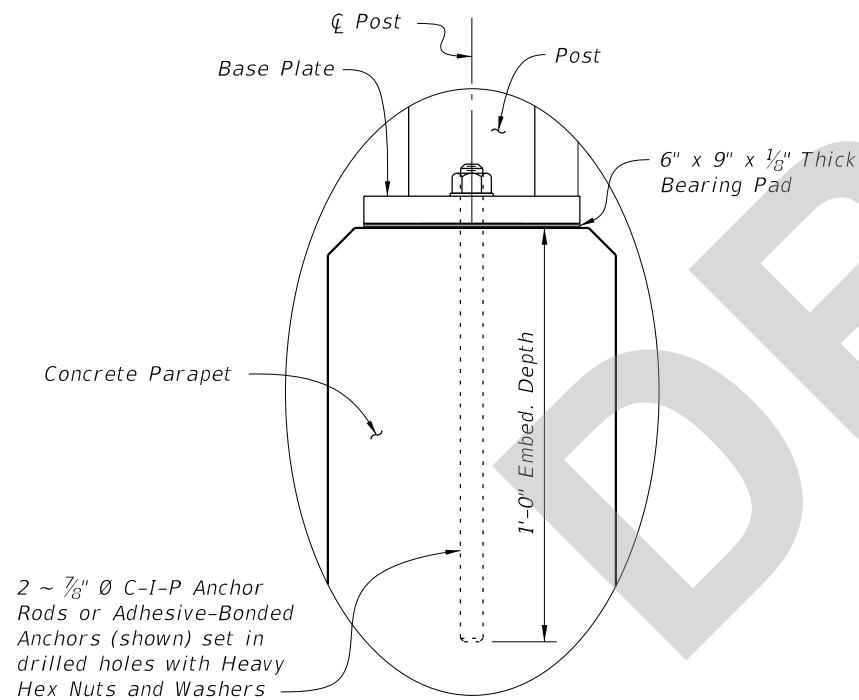

DETAIL "A"

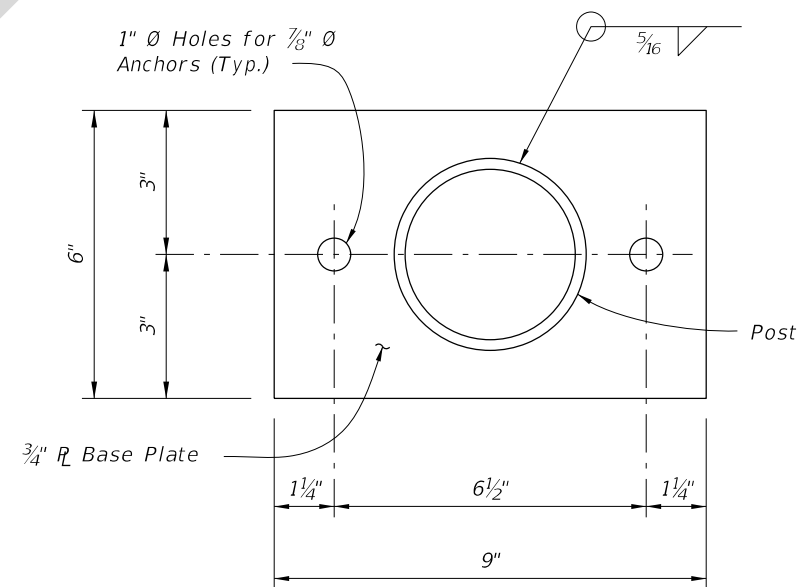

BASE PLATE DETAIL

CROSS REFERENCE:

For location of Detail "A" see Sheet 1.

5/31/2024 11:02:24 AM

LAST REVISION 11/01/24	REVISION	DESCRIPTION:	 FY 2025-26 STANDARD PLANS	BRIDGE FENCING ON PARAPET (CURVED TOP)	INDEX 550-011	SHEET 3 of 3
---------------------------	----------	--------------	---	---	-------------------------	------------------------