

Origination Form

Proposed Revisions to a Standard Plans Index

Originator:	Turley, Joshua	Index Number:	460-473
Date:	5/15/2024	Sheet Number(s):	2, 4
E-mail:	Joshua.Turley@dot.state.fl.us	Index Title:	TRAFFIC RAILING - (THRIE-BEAM RETROFIT) WIDE STRONG CURB TYPE 2

Summary of the changes:

Sheet 2: Added a note to SECTION B-B caption that what is shown is the Adhesive anchor option and screw anchor are also an option.

Sheet 4: Added a note to Plan title in Scheme 5 and 6 caption that what is shown is the Adhesive anchor option and screw anchor are also an option. Adjusted the column location to correct for missing blocks.

Commentary/Background:

Sheet 2, 4: We have recently finished research into screw anchors and are now allowing them as an option on this Standard and we needed to add a note clarifying that that is the case. Otherwise the user might think that what is shown is the only option.

Other Affected Documents/Offices	Person Contacted	Affected (Yes/No)
Other Standard Plans		No
FDOT Design Manual		No
Standard Specifications		No
Basis of Estimates Manual		No
Approved Product List		No
Construction Office		No
Maintenance Office		No

Implementation

["FY-Standard Plans (Next Release)"]

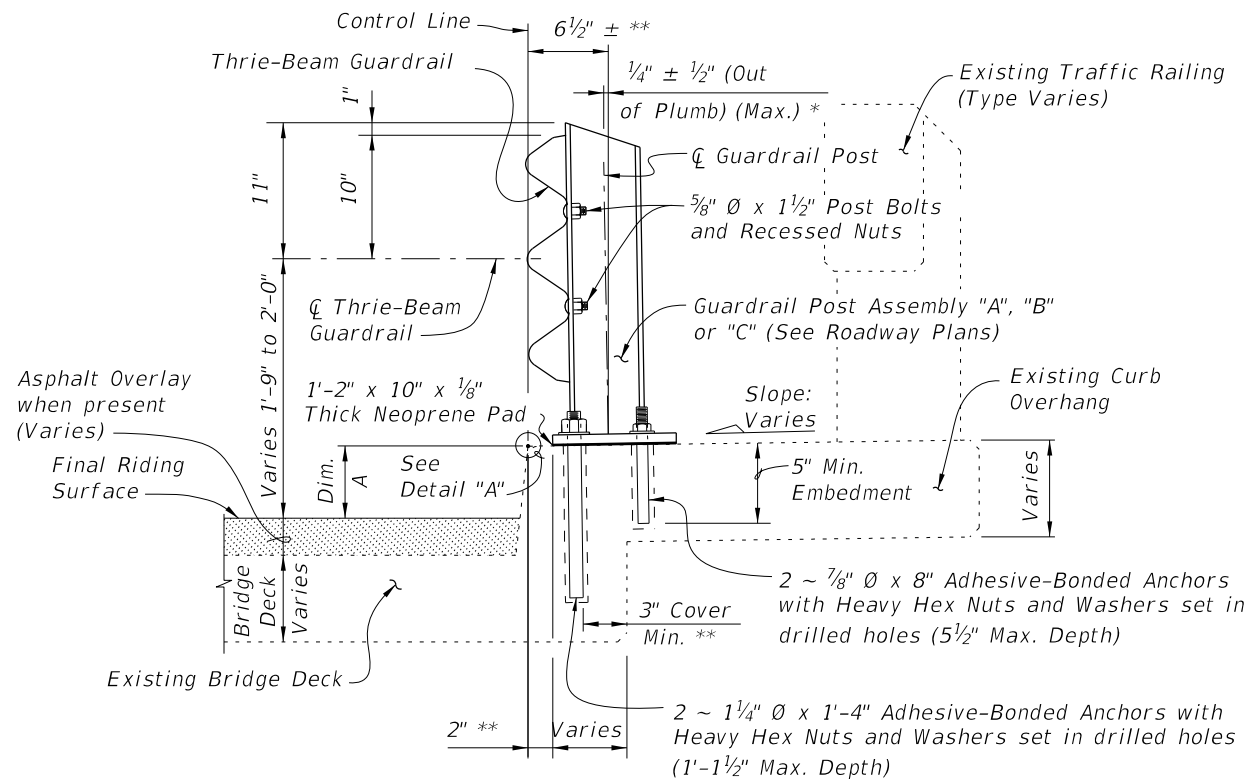

SECTION A-A
TYPICAL SECTION THRU RAILING ON BRIDGE DECK

ADDED: Screw Anchor Detail

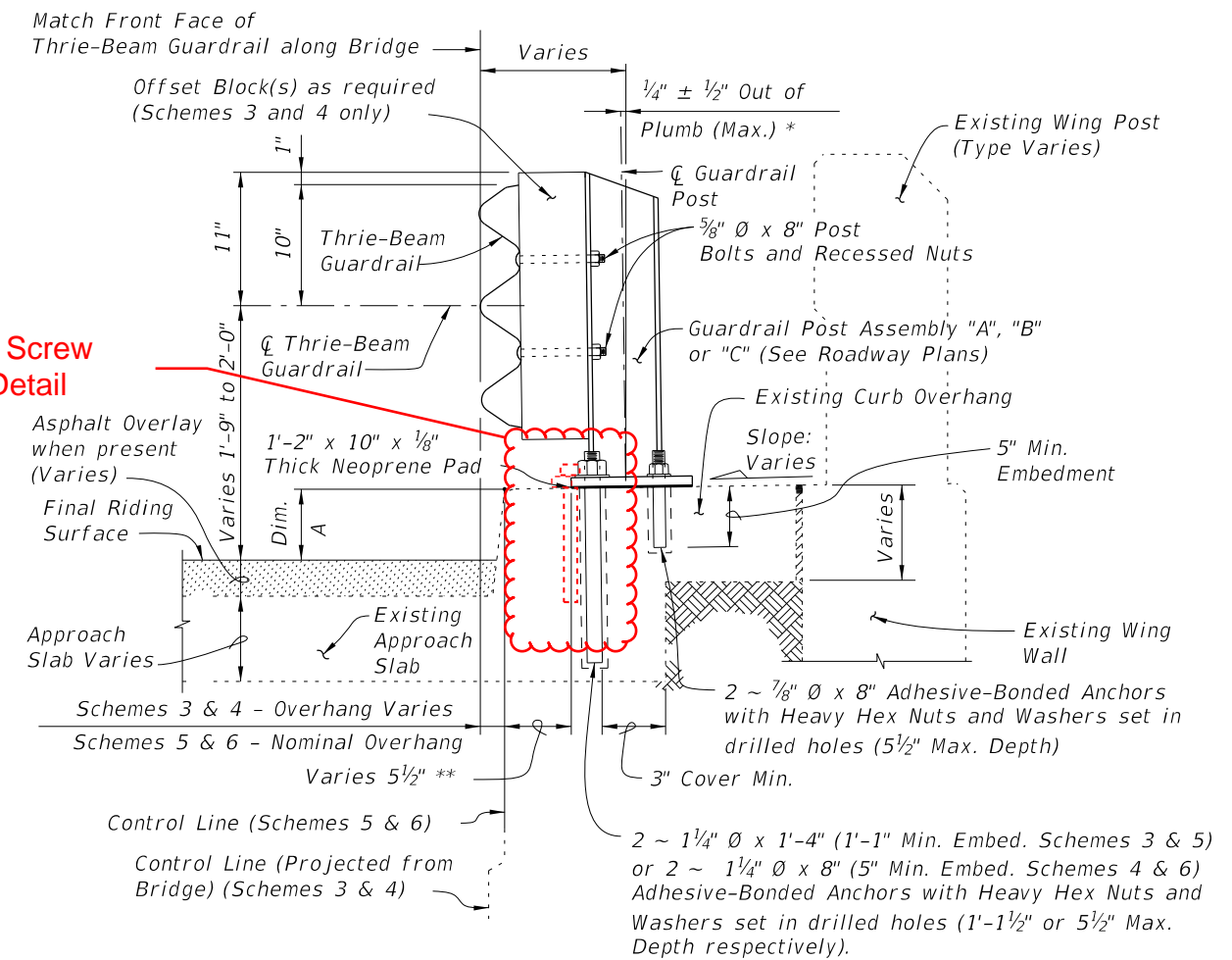

SECTION B-B
TYPICAL SECTION THRU RAILING ALONG APPROACH SLAB
(SCHEMES 5 AND 6 SHOWN, SCHEMES 3 AND 4 SIMILAR)

(Adhesive Anchor Option shown, Screw Anchor Option shown dashed)

- * Shim with washers around Anchor Bolts and Anchors as required to maintain tolerance.
- ** Offset may vary ± 1 " for Adhesive-Bonded Anchors and Anchor Bolts to clear existing curb reinforcing and provide minimum edge clearance. Offset shall be consistent along length of bridge.

BILL OF REINFORCING STEEL			BAR BENDING DIAGRAMS	
MARK	SIZE	LENGTH		
D	4	3'-7"		
L	4	4'-1"		
M	4	2'-8"		

NOTE: All bar dimensions are out to out.

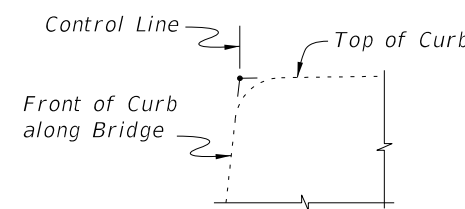

DETAIL "A"

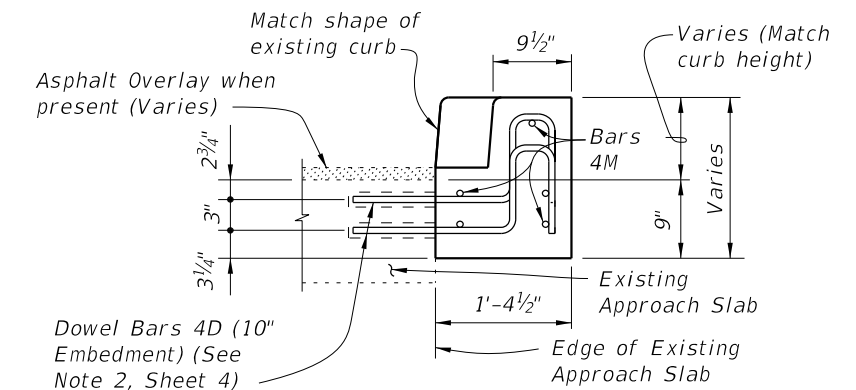

VIEW C-C

CROSS REFERENCES:

- For location of Section A-A see Sheet 1, 3 and 4.
- For location of Section B-B see Sheet 4.
- For location of View C-C see Sheet 3.
- For Traffic Railing Notes and Details see Index 460-470.
- For application of Dim. A see Post Dimension Table on Index 460-470, Sheet 3.

10/14/2022 8:06:09 AM

LAST REVISION	DESCRIPTION:
07/01/08 11/01/24	



FY 2023-24
STANDARD PLANS

TRAFFIC RAILING - (THRIE-BEAM RETROFIT)
WIDE STRONG CURB TYPE 2

INDEX
460-473

SHEET
2 of 4

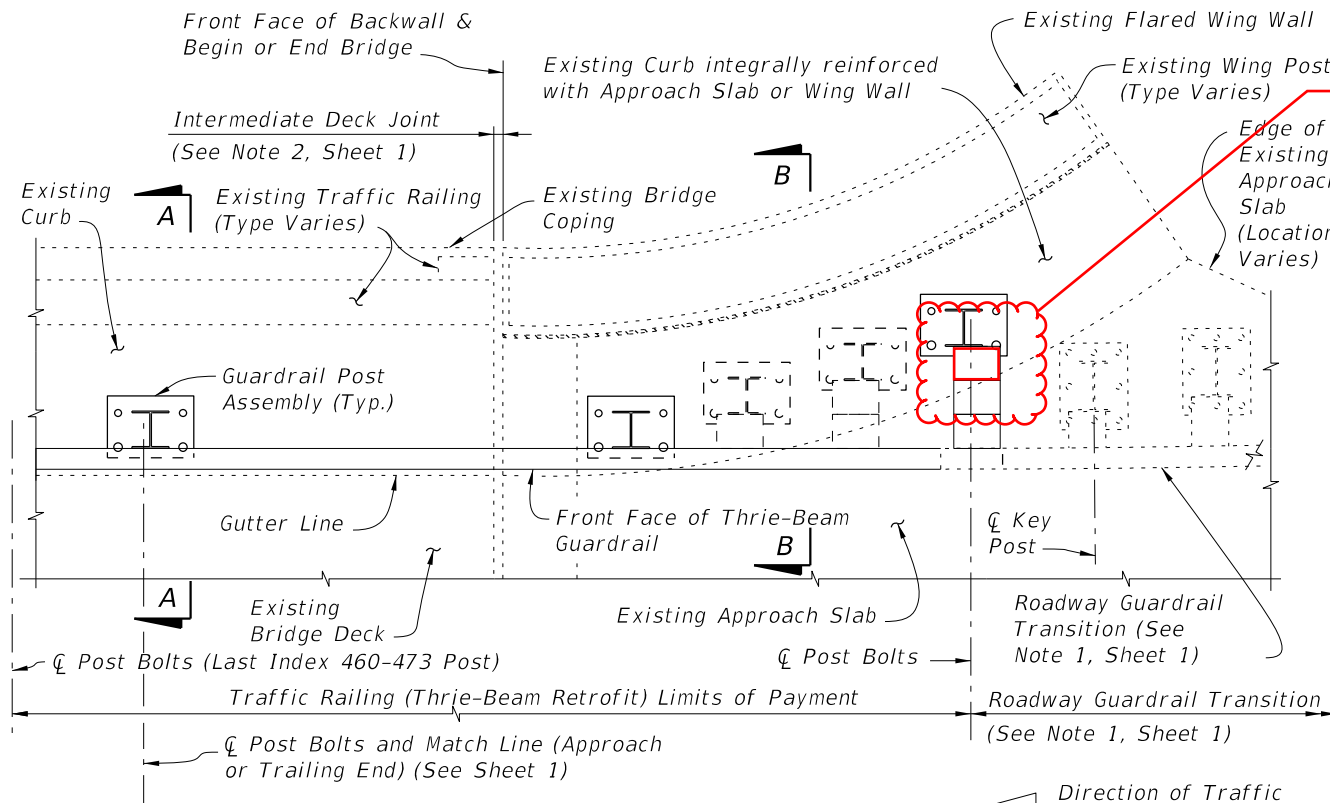

PARTIAL PLAN OF RAILING

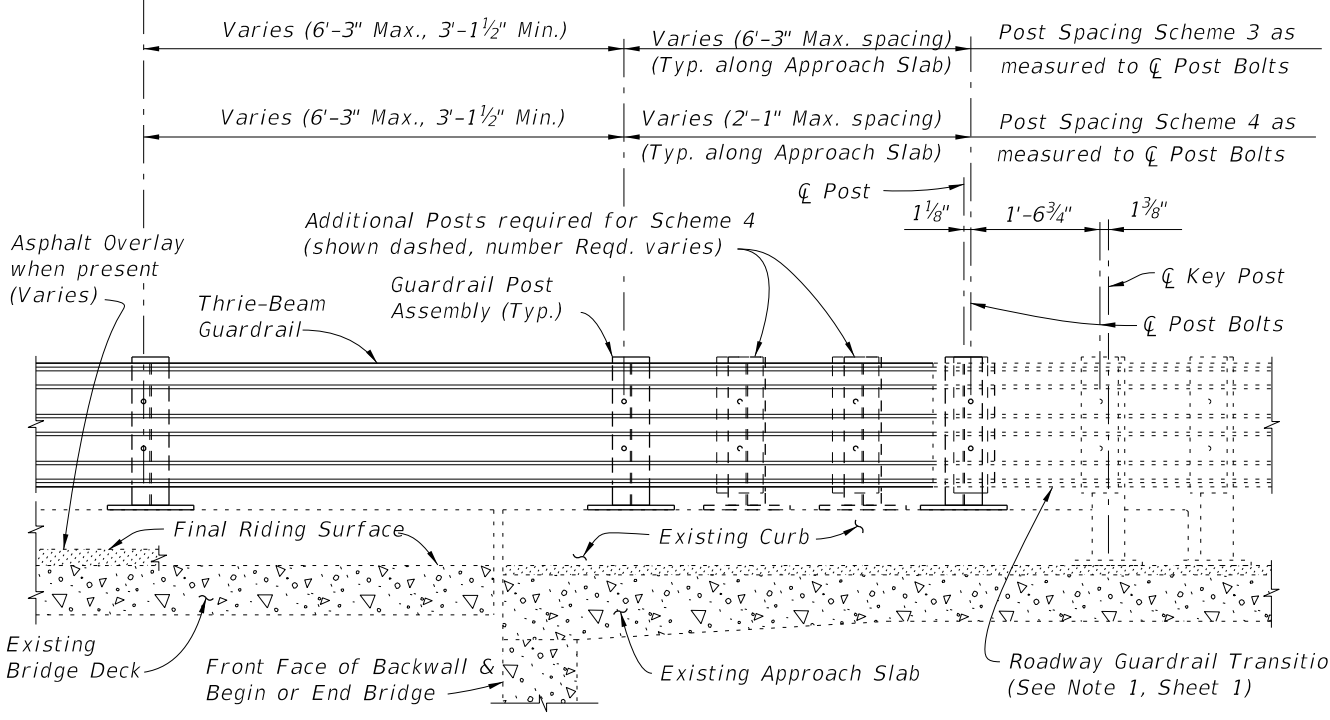

PARTIAL ELEVATION OF INSIDE FACE OF RAILING
(Existing Wing Post and Traffic Railing not shown for clarity)
SCHEMES 3 AND 4
RAILING END TREATMENT FOR FLARED INTEGRAL CURBS

Adjusted Column Locations

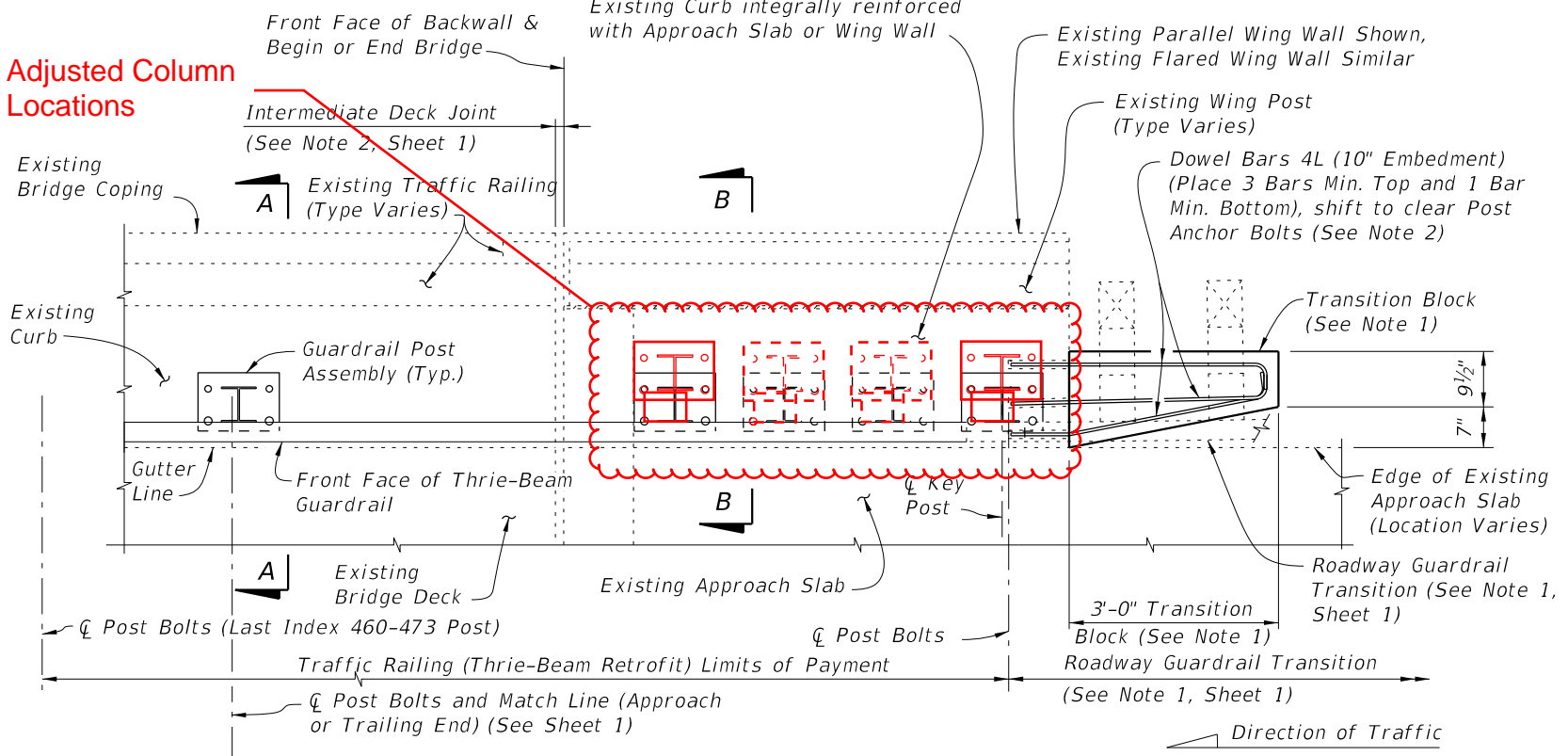

PARTIAL PLAN OF RAILING

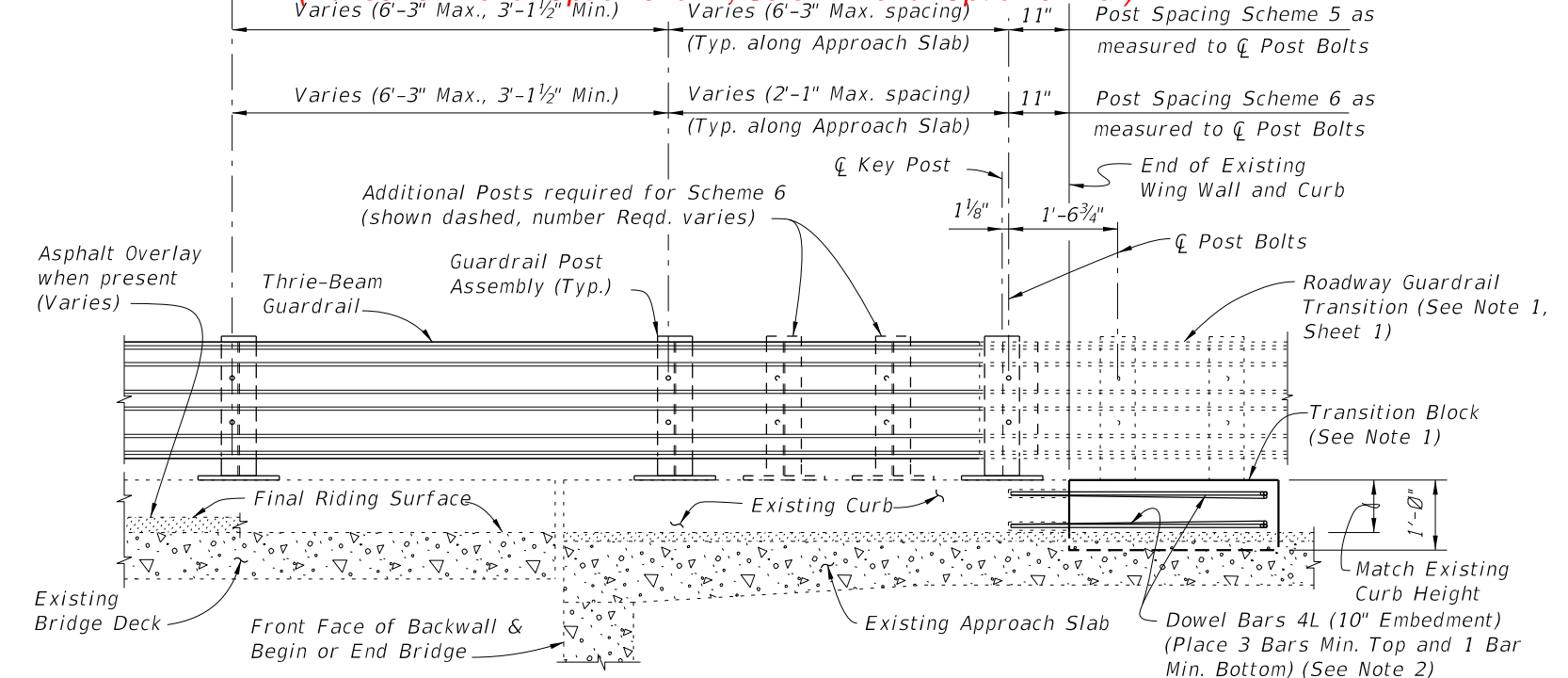

PARTIAL ELEVATION OF INSIDE FACE OF RAILING
(Existing Wing Post and Traffic Railing not shown for clarity)
SCHEMES 5 AND 6
RAILING END TREATMENT FOR PARALLEL INTEGRAL CURBS

- SCHEMES 5 AND 6 NOTES:
1. Provide Transition Block (as shown) or Curb if existing Approach Slab Curb does not extend to end of Approach Slab. Shape and height of Transition Block or Curb shall match existing bridge curb. Transition Block may be omitted on trailing ends with no opposing traffic.
 2. Field bend Dowel Bars 4L within Transition Block as required to maintain 2" top and side clearance and 3" bottom clearance.

10/14/2022 8:06:13 AM

LAST REVISION 01/01/08 11/01/24	REVISION	DESCRIPTION:		FY 2023-24 STANDARD PLANS	TRAFFIC RAILING - (THRIE-BEAM RETROFIT) WIDE STRONG CURB TYPE 2	INDEX 460-473	SHEET 4 of 4
---------------------------------------	----------	--------------	--	------------------------------	--	------------------	-----------------

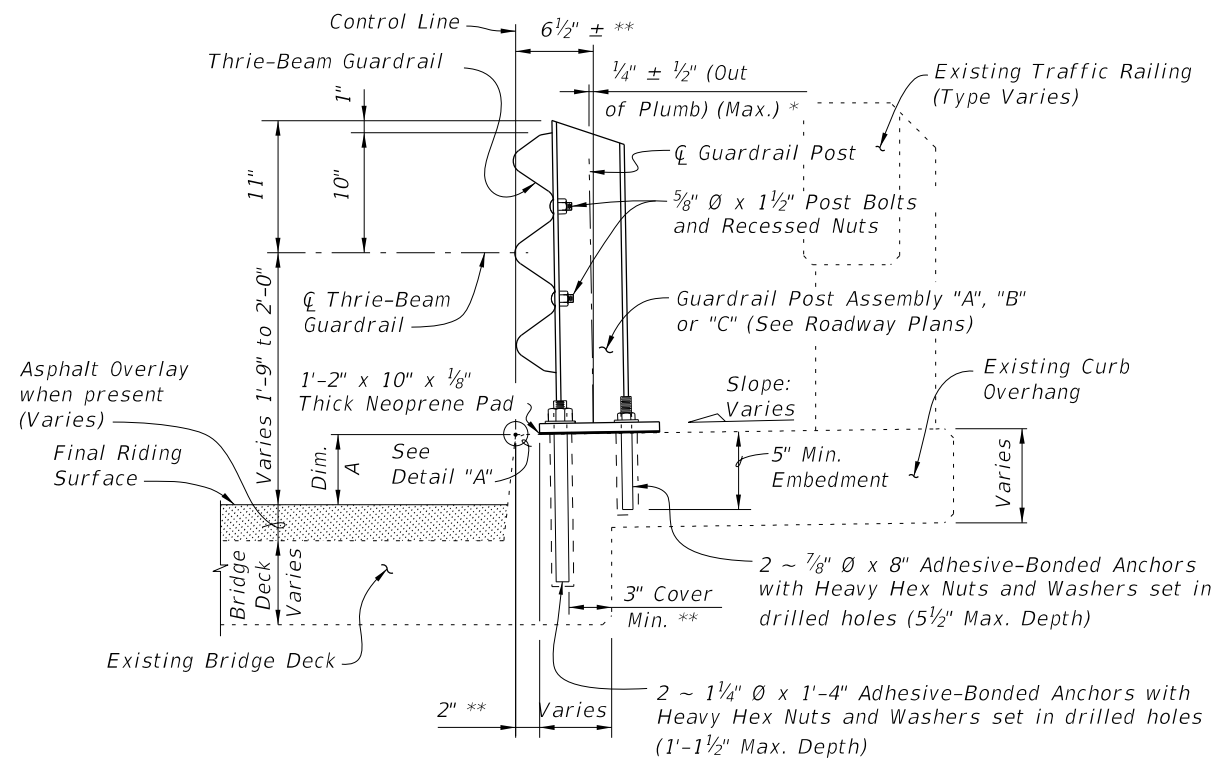

SECTION A-A
TYPICAL SECTION THRU RAILING ON BRIDGE DECK

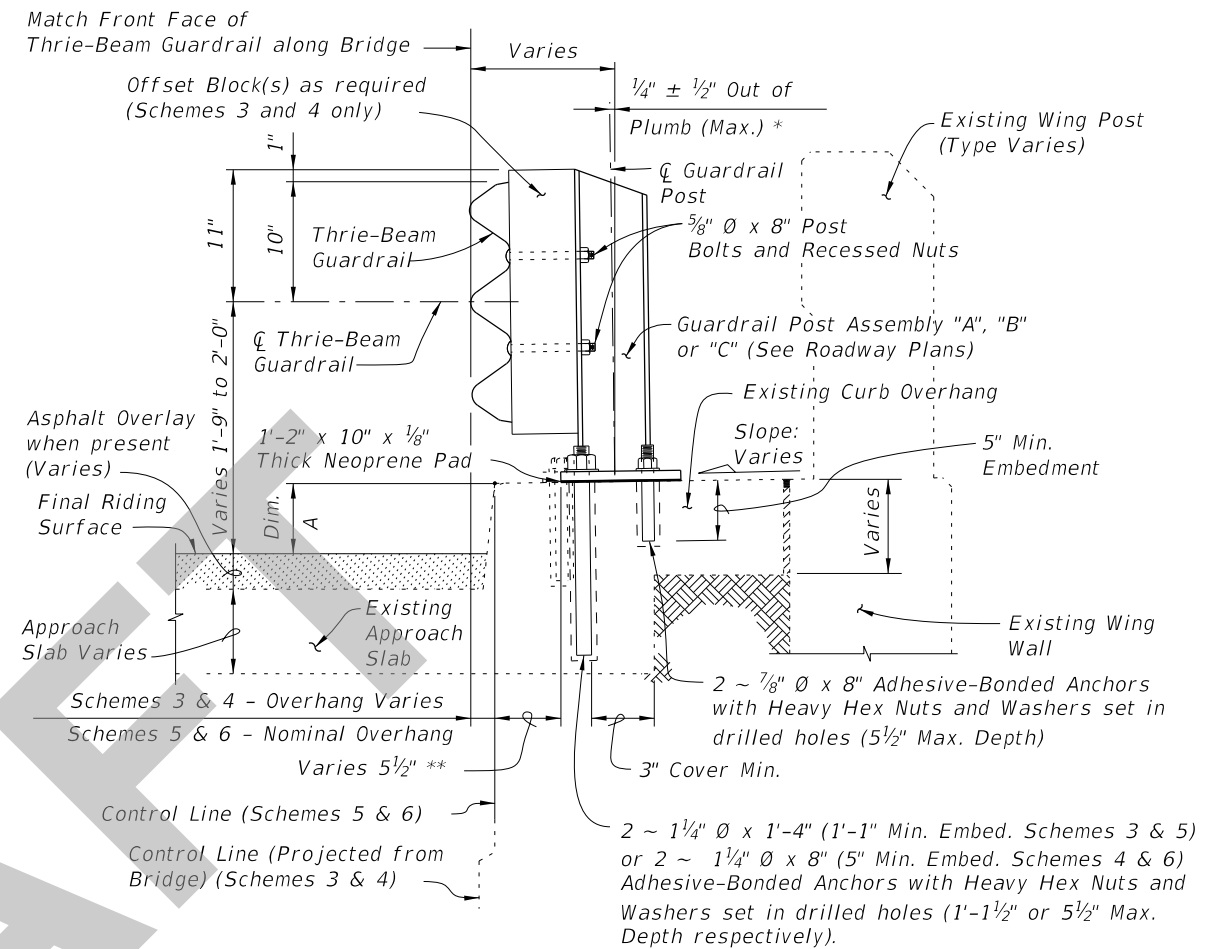

SECTION B-B
TYPICAL SECTION THRU RAILING ALONG APPROACH SLAB
(SCHEMES 5 AND 6 SHOWN, SCHEMES 3 AND 4 SIMILAR)
(Adhesive Anchor Option shown solid, Screw Anchor Option shown dashed)

BILL OF REINFORCING STEEL			BAR BENDING DIAGRAMS	
MARK	SIZE	LENGTH		
D	4	3'-7"		
L	4	4'-1"		
M	4	2'-8"		

NOTE: All bar dimensions are out to out.

* Shim with washers around Anchor Bolts and Anchors as required to maintain tolerance.
** Offset may vary $\pm 1"$ for Adhesive-Bonded Anchors and Anchor Bolts to clear existing curb reinforcing and provide minimum edge clearance. Offset shall be consistent along length of bridge.

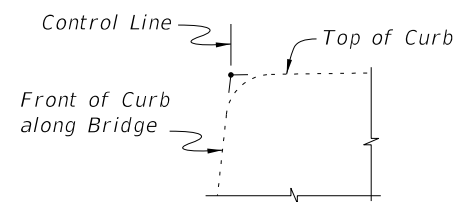

DETAIL "A"

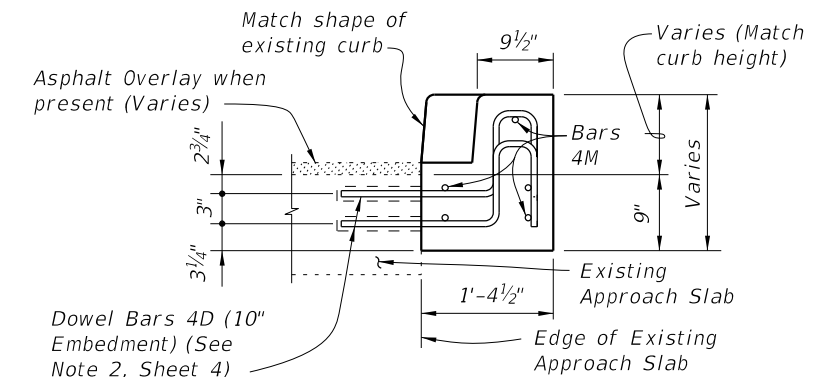

VIEW C-C

CROSS REFERENCES:
For location of Section A-A see Sheet 1, 3 and 4.
For location of Section B-B see Sheet 4.
For location of View C-C see Sheet 3.
For Traffic Railing Notes and Details see Index 460-470.
For application of Dim. A see Post Dimension Table on Index 460-470, Sheet 3.

5/31/2024 8:03:11 AM

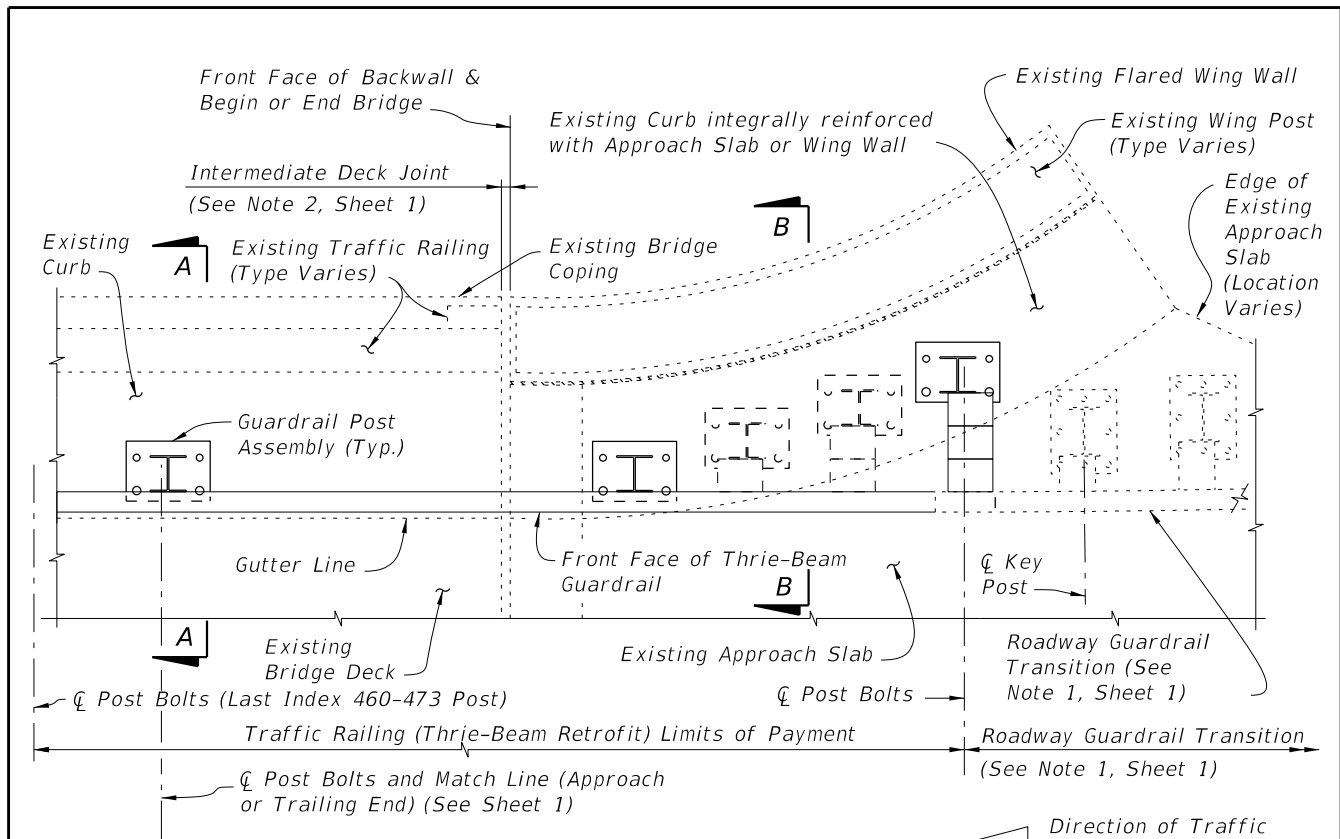

PARTIAL PLAN OF RAILING

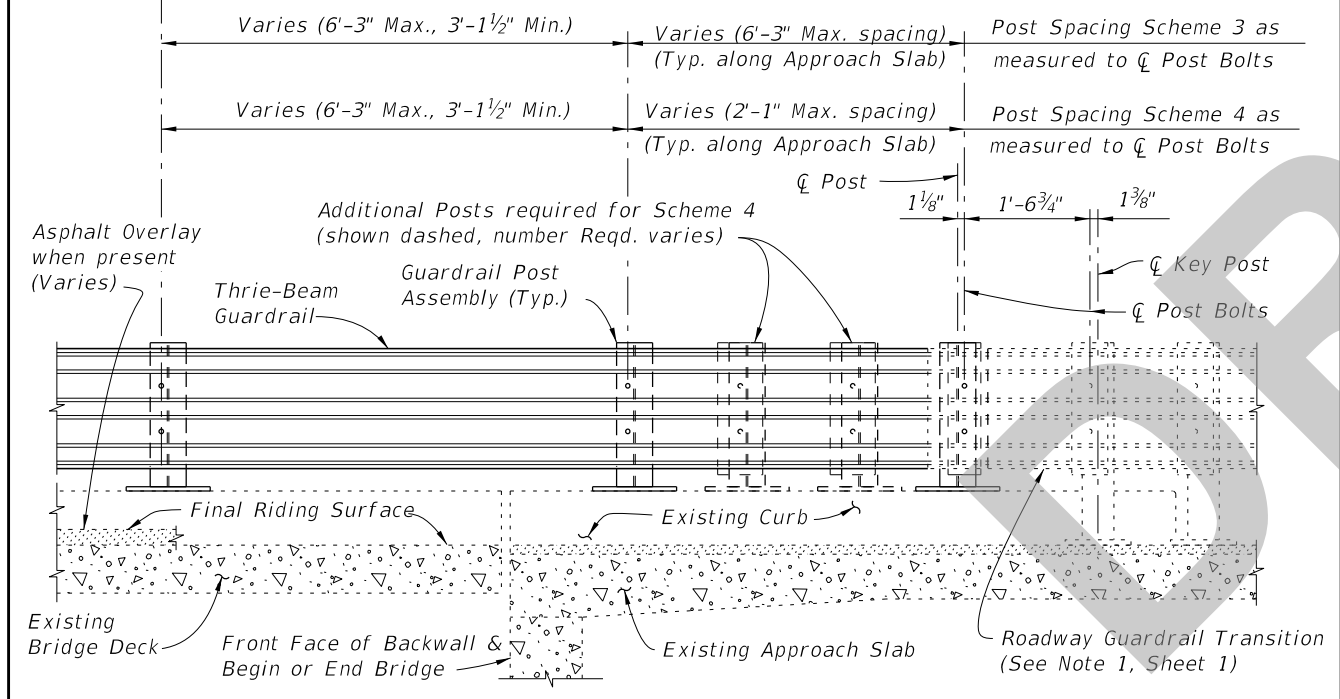

PARTIAL ELEVATION OF INSIDE FACE OF RAILING
(Existing Wing Post and Traffic Railing not shown for clarity)

SCHEMES 3 AND 4
RAILING END TREATMENT FOR FLARED INTEGRAL CURBS

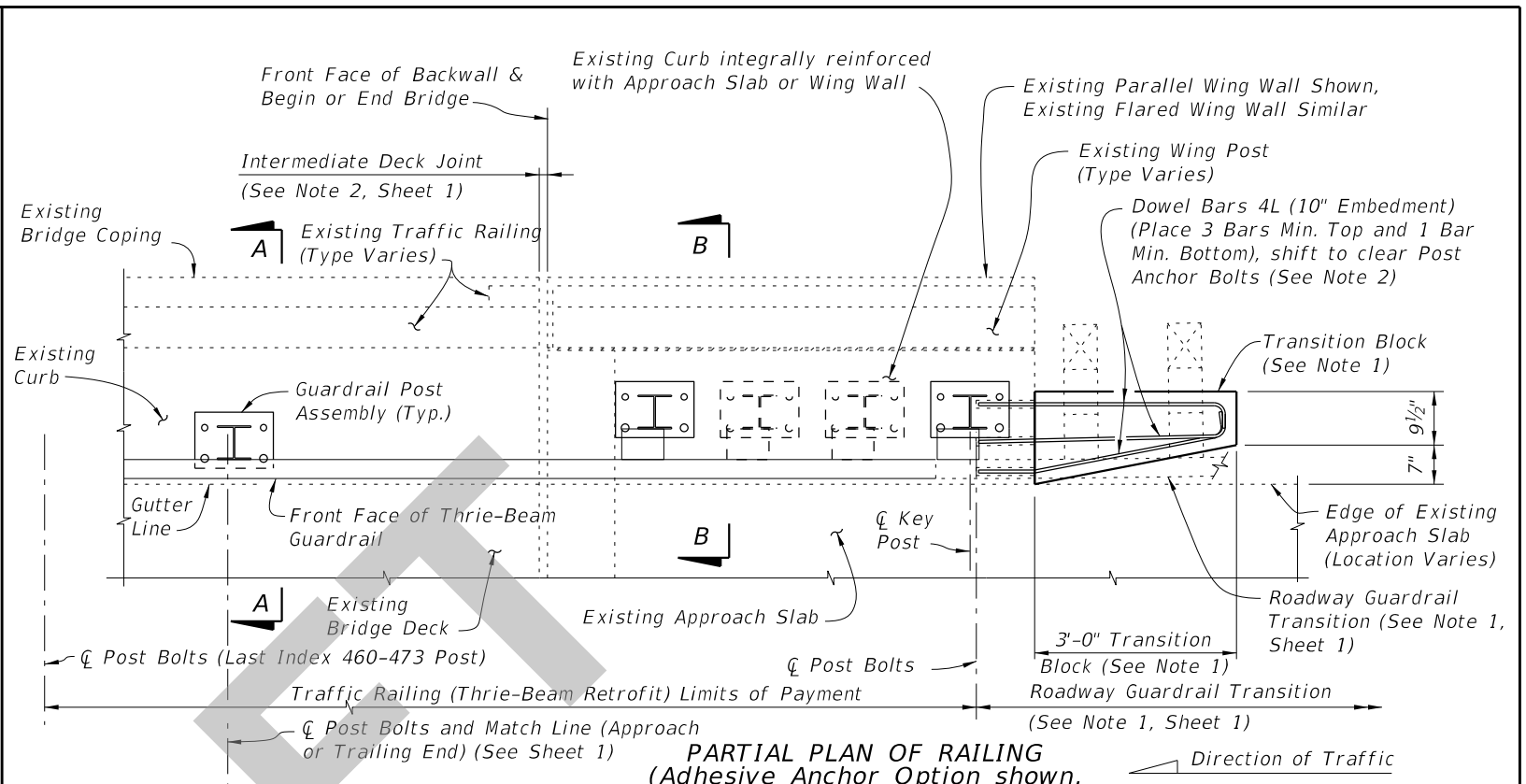

PARTIAL PLAN OF RAILING
(Adhesive Anchor Option shown, Screw Anchor Option similar)

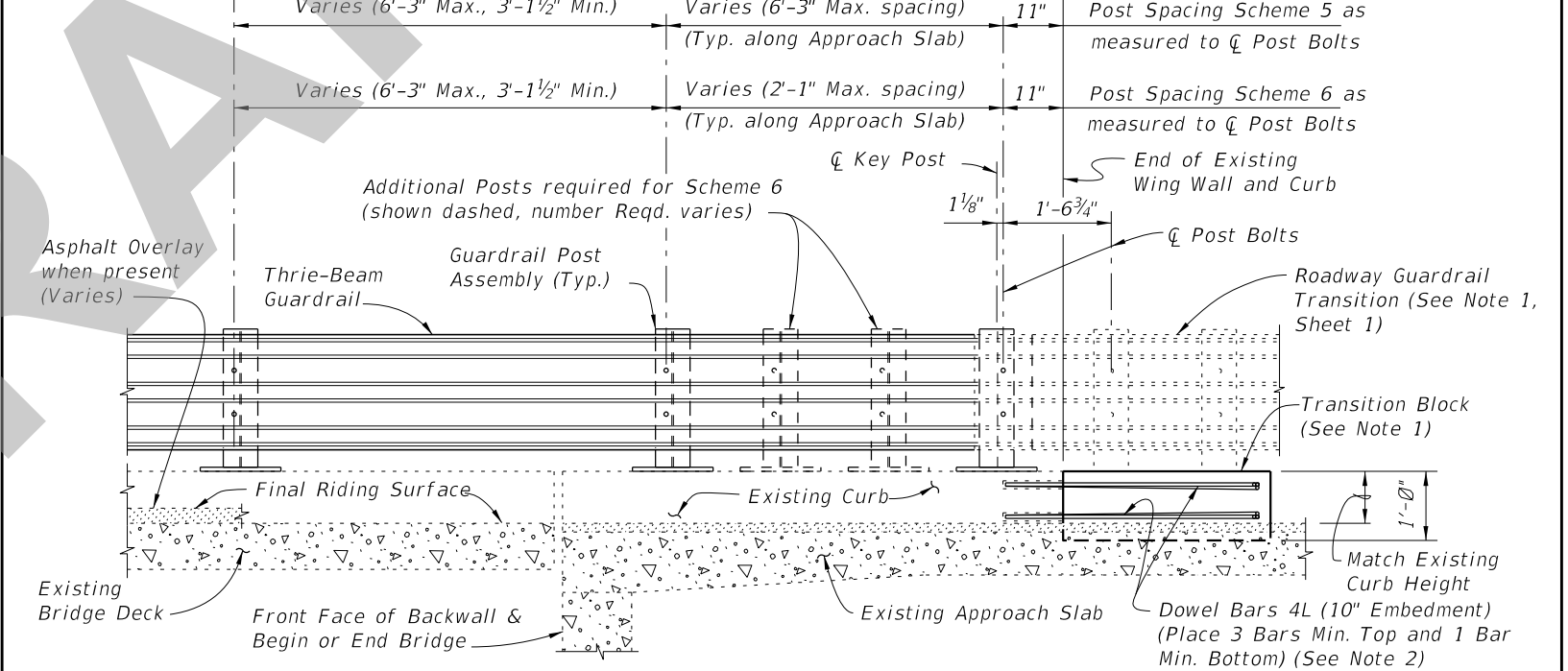

PARTIAL ELEVATION OF INSIDE FACE OF RAILING
(Existing Wing Post and Traffic Railing not shown for clarity)

SCHEMES 5 AND 6
RAILING END TREATMENT FOR PARALLEL INTEGRAL CURBS

- SCHEMES 5 AND 6 NOTES:**
1. Provide Transition Block (as shown) or Curb if existing Approach Slab Curb does not extend to end of Approach Slab. Shape and height of Transition Block or Curb shall match existing bridge curb. Transition Block may be omitted on trailing ends with no opposing traffic.
 2. Field bend Dowel Bars 4L within Transition Block as required to maintain 2" top and side clearance and 3" bottom clearance.

8/03/24 AM
5/31/2024

LAST REVISION 11/01/24	REVISION	DESCRIPTION:	 FY 2025-26 STANDARD PLANS	TRAFFIC RAILING - (THRIE-BEAM RETROFIT) WIDE STRONG CURB TYPE 2	INDEX 460-473	SHEET 4 of 4
---------------------------	----------	--------------	---	--	------------------	-----------------