

# Origination Form

## Proposed Revisions to a Standard Plans Index

<b>Originator:</b>	Turley, Joshua	<b>Index Number:</b>	400-289
<b>Date:</b>	5/7/2024	<b>Sheet Number(s):</b>	3,5
<b>E-mail:</b>	Joshua.Turley@dot.state.fl.us	<b>Index Title:</b>	CONCRETE BOX CULVERT DETAILS

### Summary of the changes:

Sheet 3: Updated reinforcing in the PARTIAL PLAN TOP SLAB of SINGLE BARREL BOX CULVERT so it does not appear to extend into the footer below.  
 Sheet 5: Added some clarity to Note 2 and DETAIL "C" about the proper work point location (WP)

### Commentary/Background:

Sheet 3: This was a CAD error the lines didnt stop at the correct place making it appear as if the reinforcing should extend from the top slab through to the footer which is physically impossible as they are on two different elevations.  
 Sheet 5: There was some confusion about where the proper work points were for the wingwall construction joint. The labels didnt match the diagram so we corrected this.

Other Affected Documents/Offices	Person Contacted	Affected (Yes/No)
Other Standard Plans		No
FDOT Design Manual		No
Standard Specifications		No
Basis of Estimates Manual		No
Approved Product List		No
Construction Office		No
Maintenance Office		No

### Implementation

["FY-Standard Plans (Next Release)"]

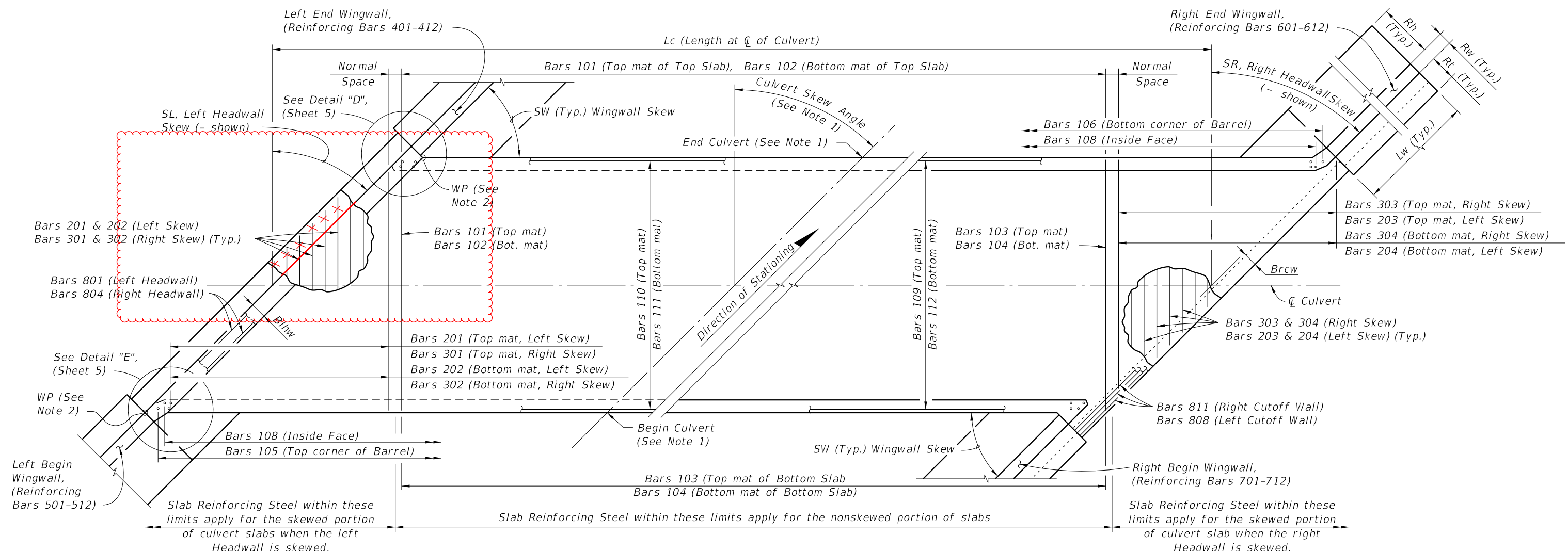

- NOTES:**
1. See Contract Plans for Culvert location, Culvert Skew Angle and Roadway Cross Section.
  2. WP = Working Point, used for wingwall layout and location of construction joint. See Detail "C" (Sheet 5).

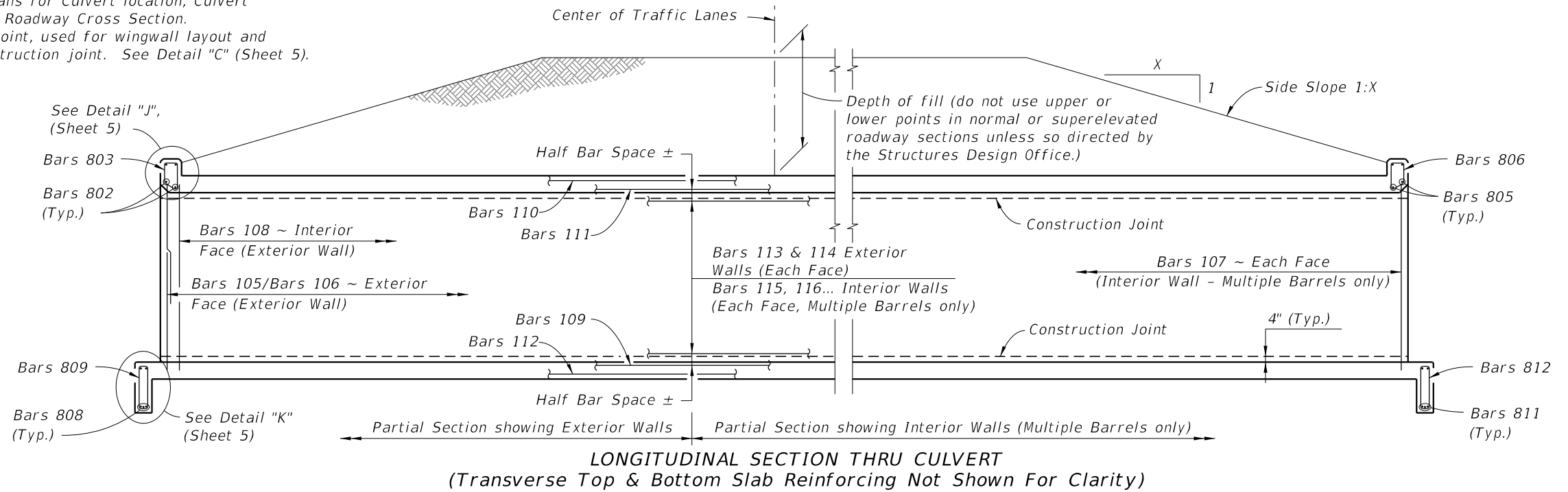

10/15/2023 11:15:21 AM

LAST REVISION	REVISION	DESCRIPTION: 11/01/2024	 FY 2024-25 STANDARD PLANS	CONCRETE BOX CULVERT DETAILS	INDEX 400-289	SHEET 3 of 8
01/01/07						

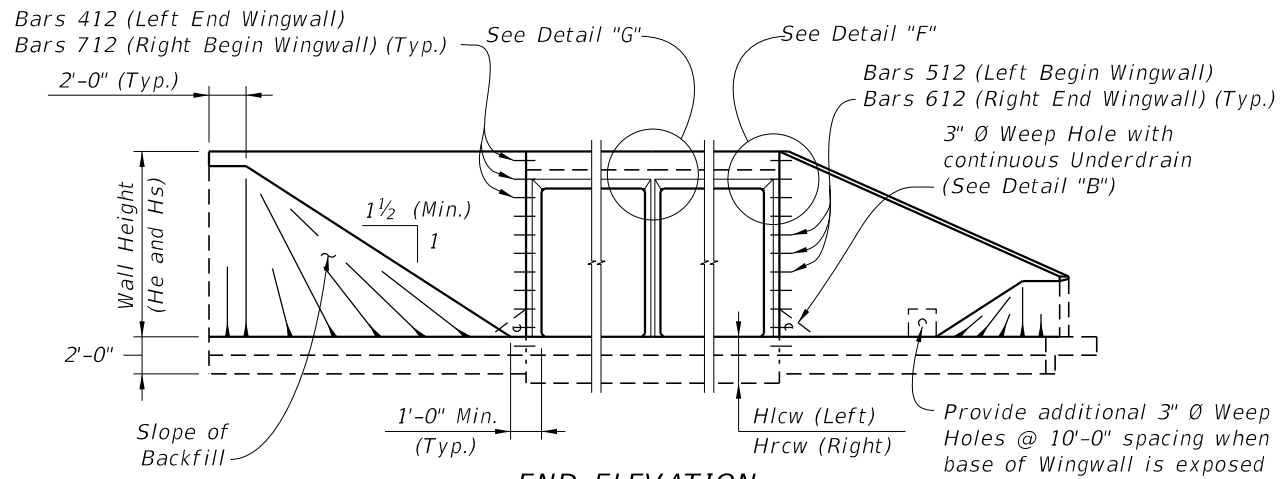

**END ELEVATION**  
 (Showing Constant Height And Variable Height Wingwalls)

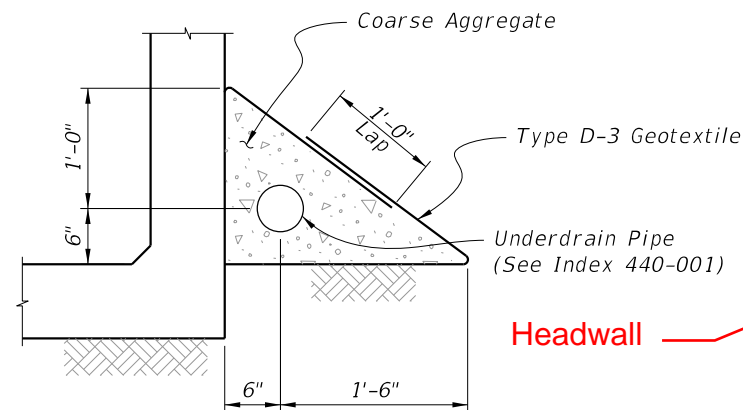

**DETAIL "B"**  
 UNDERDRAIN DETAIL  
 (Similar to Type II ~ Index 440-001)

**NOTES:**

1. For small angles, the Contractor may elect to fill the area between the box and the wingwall footing with unreinforced concrete. For wingwall skew angles less than 90 degrees, field bend wingwall reinforcement as necessary while maintaining cover. No additional payment will be made for this work.
2. Location of Construction Joint determined by WP at theoretical intersection of:
  - Soil side face of Headwall and outside face of Box Exterior Wall, for SW ≤ 90°;
  - Outside face of Wingwall and outside face of Box Exterior Wall, for SW > 90°.
3. Provide 6" chamfer when angle 'A' is greater than 45°. Maintain minimum wall thickness. Field adjust reinforcing to maintain cover.
4. Wingwall Skew Angles (SW) are measured from the adjacent box exterior wall to the wingwall.
5. Turn or extend Wingwall Cutoff Wall as necessary to meet Box Cutoff Wall.
6. Provide additional reinforcement in the top of the top slab below traffic railings to ensure a minimum area of 0.80 sq. in./ft. transverse reinforcing.

\* Included in the cost of the Traffic Railing.

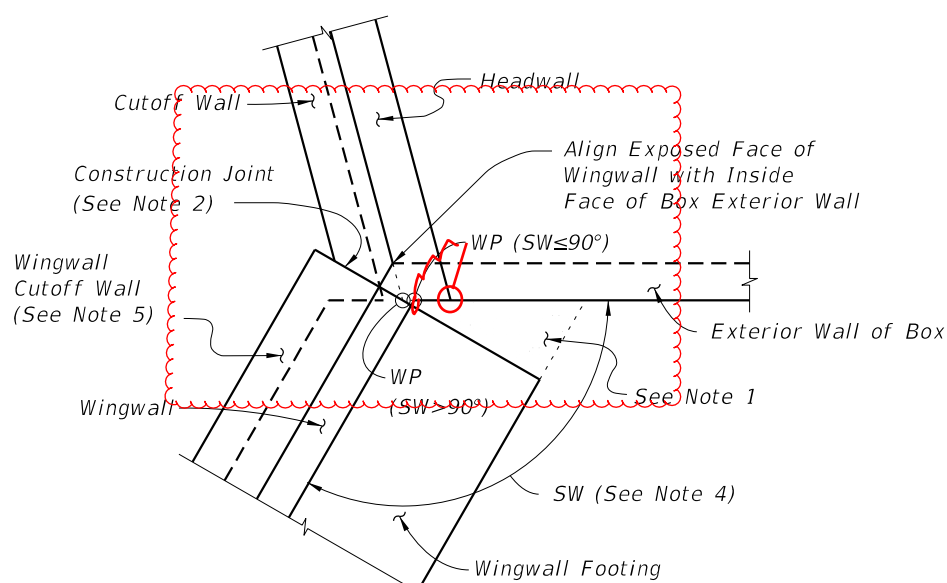

**DETAIL "C" - PLAN VIEW**  
 WINGWALL TO BOX CONNECTION  
 (Left Begin Corner Shown, Other Corners Similar)

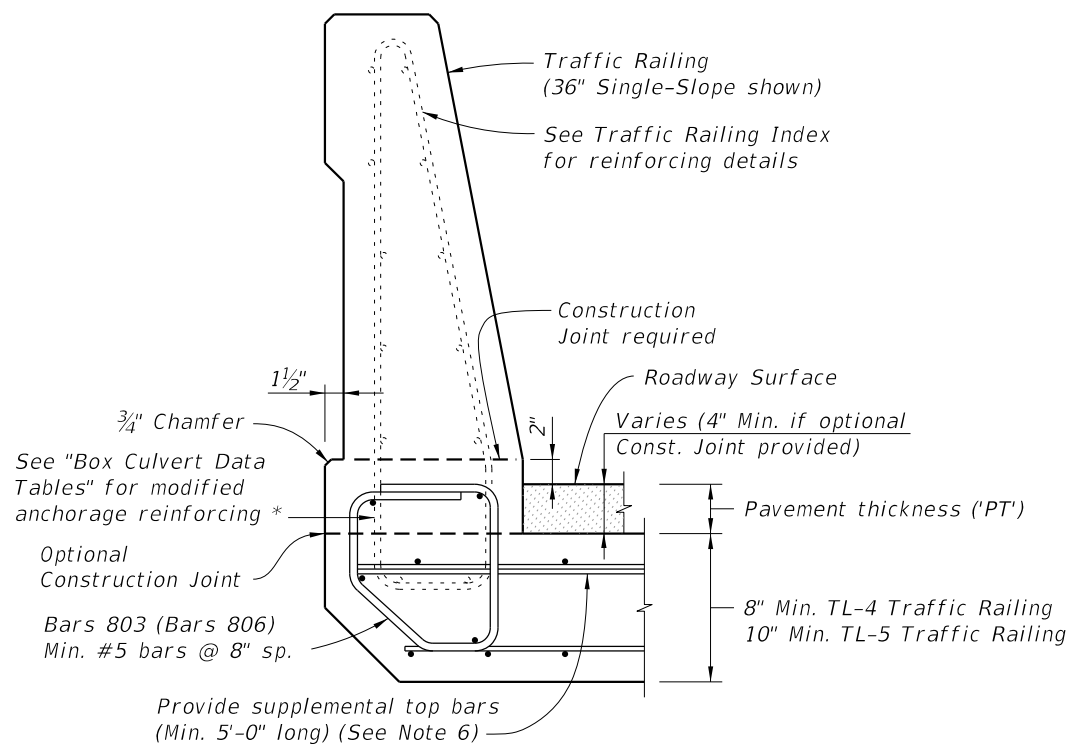

**DETAIL "I"**  
 TRAFFIC RAILING ATTACHMENT TO HEADWALL

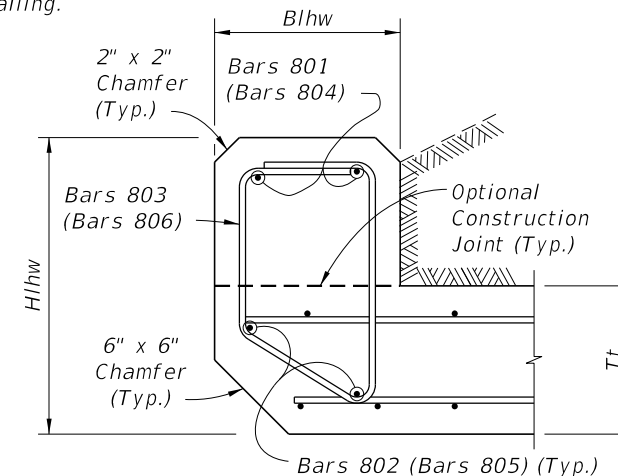

**DETAIL "J"**  
 LEFT HEADWALL SECTION  
 (Right Headwall similar)

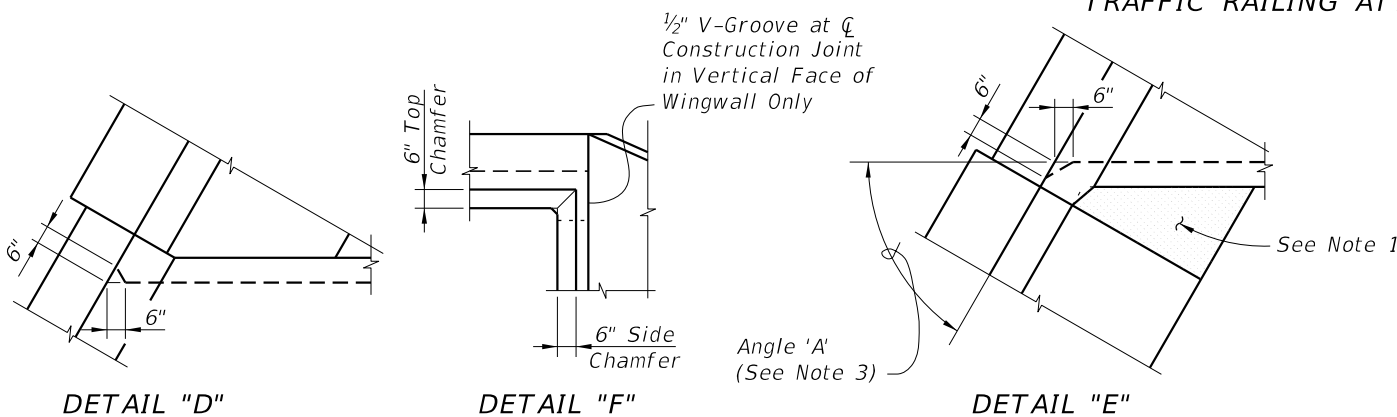

**DETAIL "D"**

**DETAIL "F"**

**DETAIL "E"**

**DETAIL "G"**

**SECTION H-H**

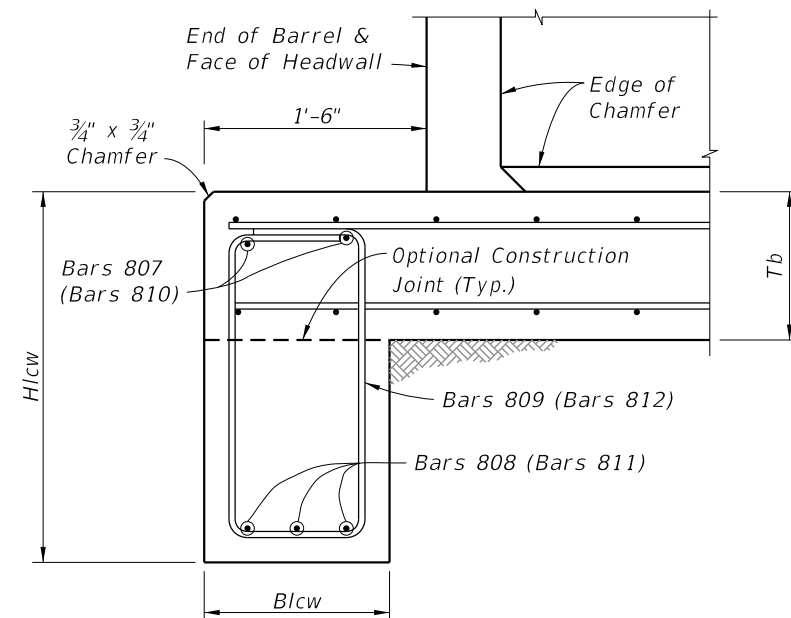

**DETAIL "K"**  
 LEFT CUTOFF WALL SECTION  
 (Right Cutoff Wall similar)

**CROSS REFERENCE:**  
 See Sheet 3 for locations of Details "D", "E", "J" & "K".  
 See Sheet 4 for locations of Detail "C".

10/24/2023 11:18:13 AM

LAST REVISION 11/01/23	REVISION	DESCRIPTION: 11/01/2024		FY 2024-25 STANDARD PLANS	CONCRETE BOX CULVERT DETAILS	INDEX 400-289	SHEET 5 of 8
---------------------------	----------	----------------------------	--	------------------------------	------------------------------	------------------	-----------------

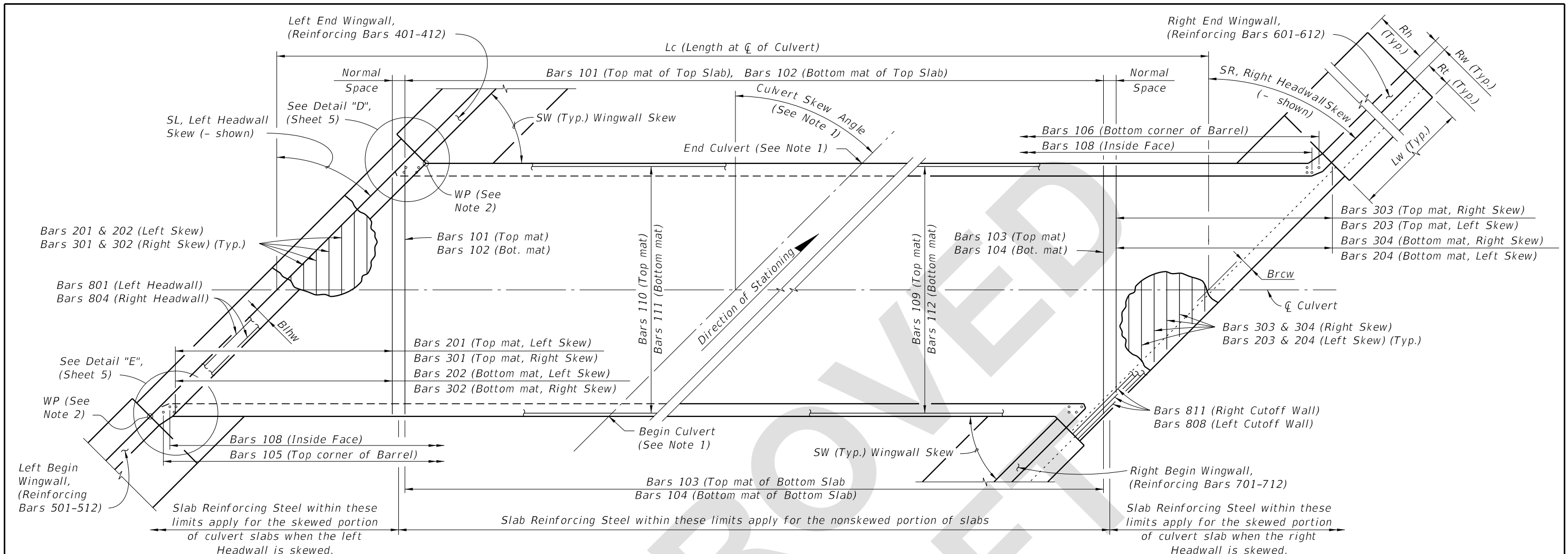

**PARTIAL PLAN TOP SLAB**  
(Left Side, Left Skew)

**SINGLE BARREL BOX CULVERT**  
(Skewed Culvert With Parallel Wingwalls Shown)

**PARTIAL PLAN BOTTOM SLAB**  
(Right Side, Right Skew)

- NOTES:**
1. See Contract Plans for Culvert location, Culvert Skew Angle and Roadway Cross Section.
  2. WP = Working Point, used for wingwall layout and location of construction joint. See Detail "C" (Sheet 5).

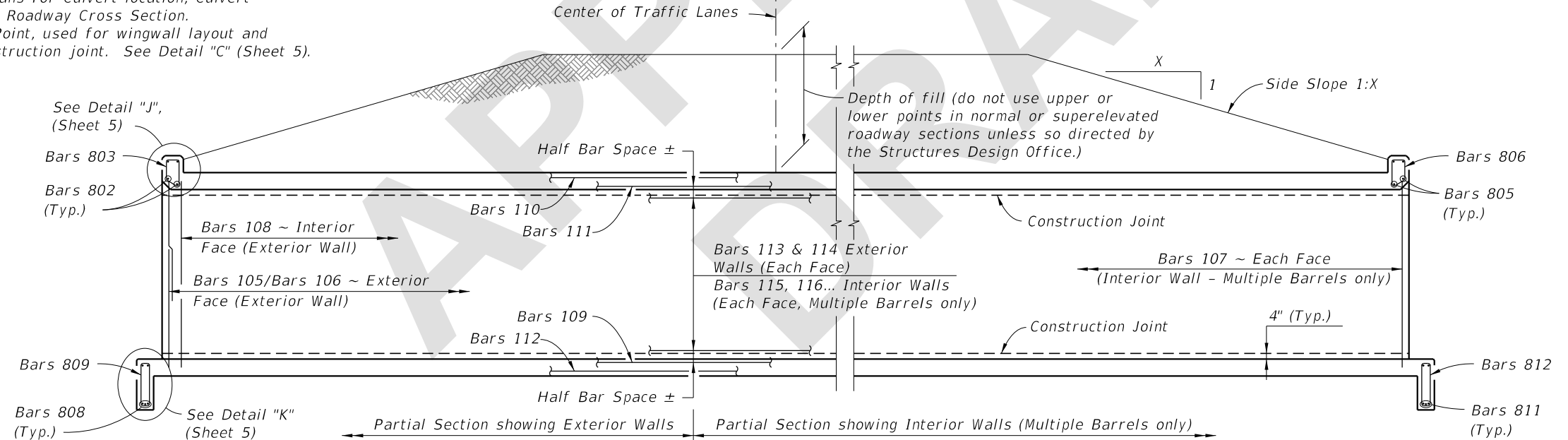

**LONGITUDINAL SECTION THRU CULVERT**  
(Transverse Top & Bottom Slab Reinforcing Not Shown For Clarity)

5/31/2024 7:49:14 AM

LAST REVISION <b>11/01/24</b>	DESCRIPTION:	 <b>FY 2025-26</b> <b>STANDARD PLANS</b>	<b>CONCRETE BOX CULVERT DETAILS</b>	INDEX <b>400-289</b>	SHEET <b>3 of 8</b>
----------------------------------	--------------	--	-------------------------------------	-------------------------	------------------------

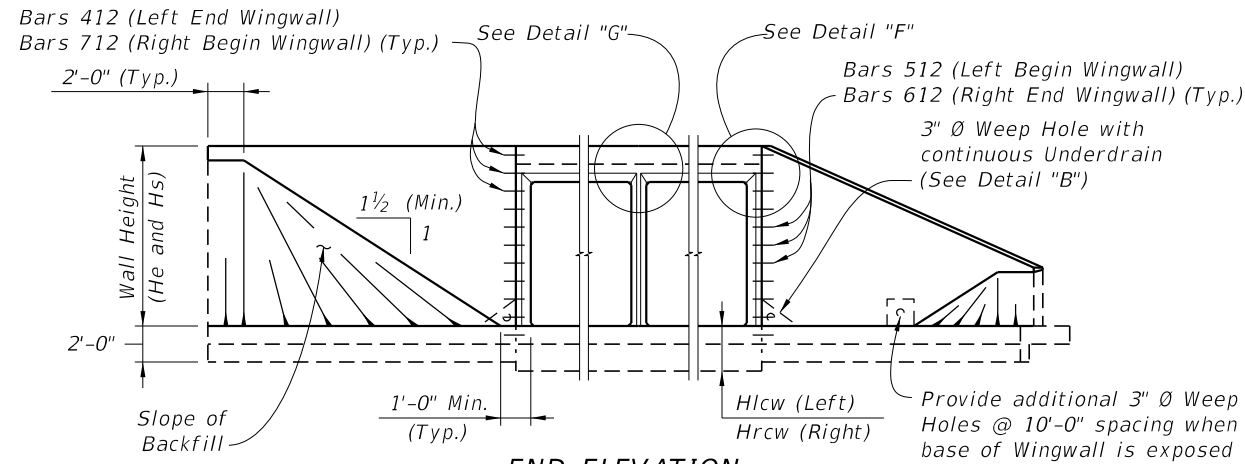

**END ELEVATION**  
(Showing Constant Height And Variable Height Wingwalls)

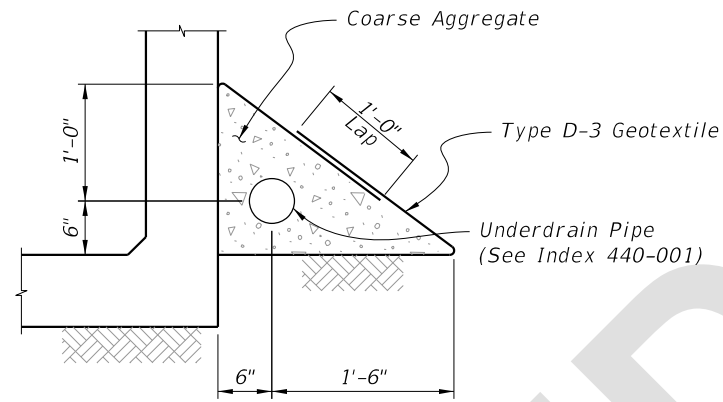

**DETAIL "B"**  
**UNDERDRAIN DETAIL**  
(Similar to Type II ~ Index 440-001)

**NOTES:**

1. For small angles, the Contractor may elect to fill the area between the box and the wingwall footing with unreinforced concrete. For wingwall skew angles less than 90 degrees, field bend wingwall reinforcement as necessary while maintaining cover. No additional payment will be made for this work.
2. Location of Construction Joint determined by WP at theoretical intersection of:
  - Soil side face of Headwall and outside face of Box Exterior Wall, for  $SW \leq 90^\circ$ ;
  - Outside face of Headwall and outside face of Box Exterior Wall, for  $SW > 90^\circ$ .
3. Provide 6" chamfer when angle 'A' is greater than 45°. Maintain minimum wall thickness. Field adjust reinforcing to maintain cover.
4. Wingwall Skew Angles (SW) are measured from the adjacent box exterior wall to the wingwall.
5. Turn or extend Wingwall Cutoff Wall as necessary to meet Box Cutoff Wall.
6. Provide additional reinforcement in the top of the top slab below traffic railings to ensure a minimum area of 0.80 sq. in./ft. transverse reinforcing.

\* Included in the cost of the Traffic Railing.

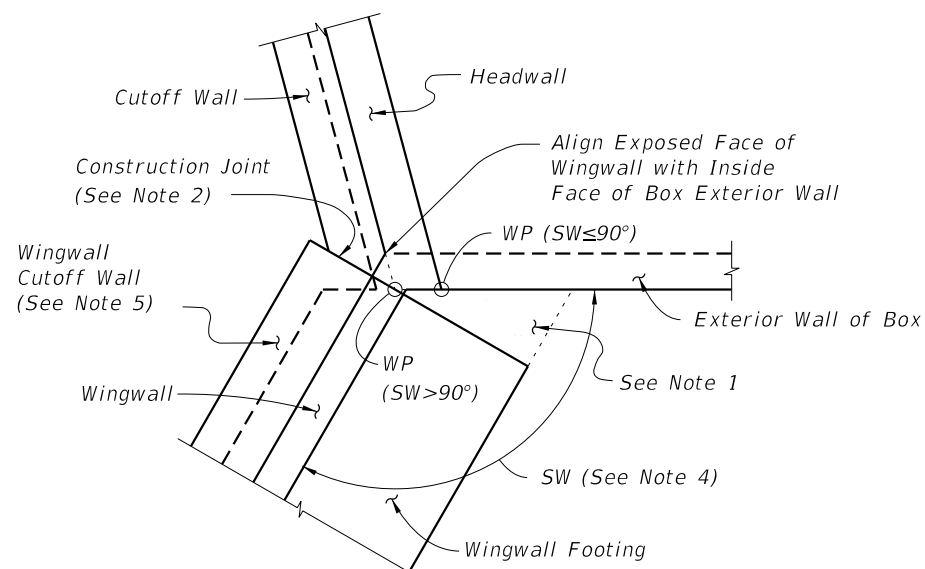

**DETAIL "C" - PLAN VIEW**  
**WINGWALL TO BOX CONNECTION**  
(Left Begin Corner Shown, Other Corners Similar)

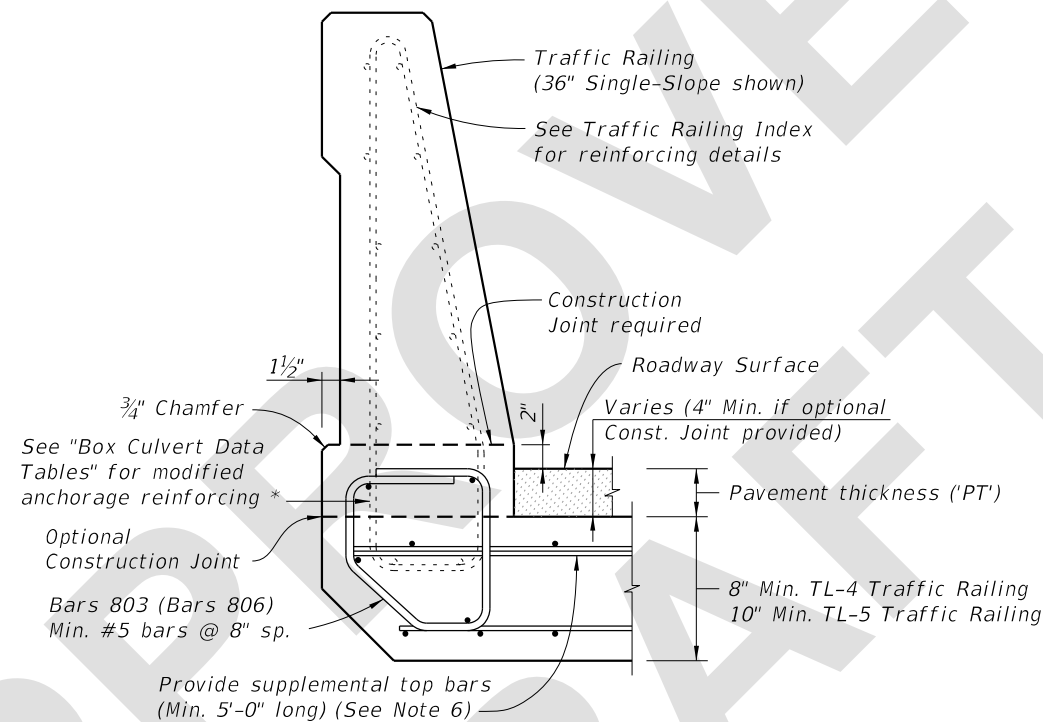

**DETAIL "I"**  
**TRAFFIC RAILING ATTACHMENT TO HEADWALL**

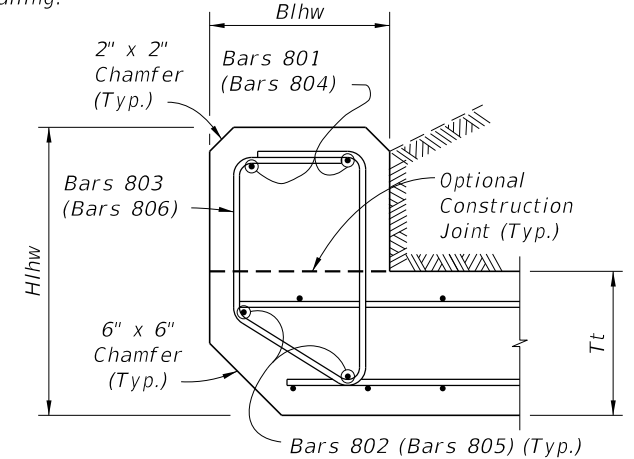

**DETAIL "J"**  
**LEFT HEADWALL SECTION**  
(Right Headwall similar)

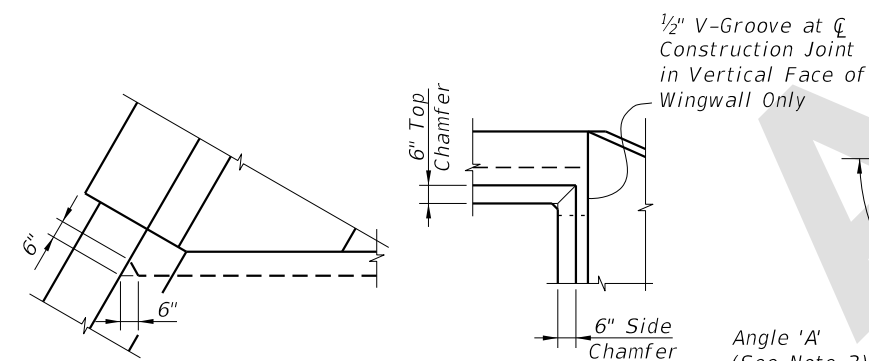

**DETAIL "D"**

**DETAIL "F"**

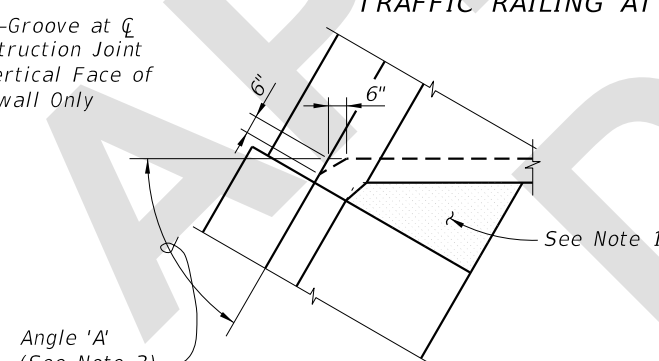

**DETAIL "E"**

**DETAIL "G"**

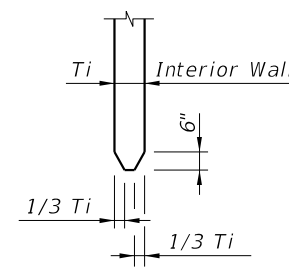

**SECTION H-H**

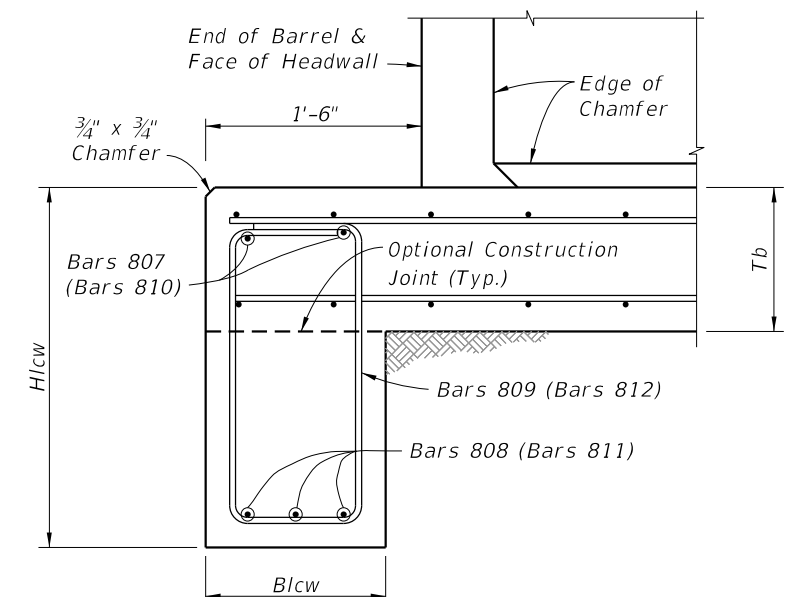

**DETAIL "K"**  
**LEFT CUTOFF WALL SECTION**  
(Right Cutoff Wall similar)

**CROSS REFERENCE:**  
See Sheet 3 for locations of Details "D", "E", "J" & "K".  
See Sheet 4 for locations of Detail "C".

5/31/2024 7:50:46 AM

<b>LAST REVISION</b> 11/01/24	<b>DESCRIPTION:</b>	 <b>FY 2025-26 STANDARD PLANS</b>	<b>CONCRETE BOX CULVERT DETAILS</b>	<b>INDEX</b> 400-289	<b>SHEET</b> 5 of 8
----------------------------------	---------------------	--	-------------------------------------	-------------------------	------------------------