

---

## Index 649-020 Steel CCTV Pole

### ORIGINATION

**Date:** June 28, 2022

**Name:** Matthew DeWitt

**Phone:** (850) 921-7353

**Email:** Matthew.Dewitt@dot.state.fl.us

### COMMENTARY

These proposed changes were developed based on implementing a maintenance service slab for ITS cabinets recommended during the TDH integration into statewide criteria. Language has also been added to Specification 676 for the maintenance service slab.

### COMMENTS AND RESPONSES

**BLACK** = Industry Review Comments   **BLUE** = Standard Plans Response   **GREEN** = Change Made to Index

**Name:** Miguel Villegas

**Date:** 8/17/2022

**COMMENT:** On sheet 6 of 6, maybe the location of the proposed maintenance slab can be shown to be cast against the shaft as opposed to being cast against the conduits. Also, will the Department consider making the maintenance slab of a standard thickness or will it need to be designed by a structural engineer.

**RESPONSE:** Agree the slab should be shown to be cast against the shaft and the conduits should be adjusted. The maintenance slab is intended to be 6" thick. This is shown in Index 676-010 but will be clarified. We will revise 641-020, 649-020 and 676-010 to show the slab thicknesses accurately.

**CHANGE TO THE INDEX:** Edit slab adjacent to shaft and adjust conduit. Edit pull boxes throughout the index to show 6" aprons to match maintenance service slabs.

*Response Date: 8/23/2022*

**GENERAL NOTES:**

1. Work this Index with Specification 649.
2. This Index is considered fully detailed; only submit shop drawings for minor modifications not detailed in the Plans.
3. See Index 635-001 for additional Pull Box details.
4. See Index 676-010 for cabinet installation details.
5. Materials:
  - A. Pole: ASTM A1011 Grade 50, 55, 60 or 65 (less than 1/4") or ASTM A572 Grade 50, 60 or 65 (greater than or equal to 1/4") or ASTM A595 Grade A (55 ksi yield) or Grade B (60 ksi yield).
  - B. Steel Plates and Pole Cap: ASTM A36 or ASTM A709 Grade 50.
  - C. Weld Metal: E70XX.
  - D. Bolts: ASTM F3125, Grade A325, Type 1.  
Nuts: ASTM A563.  
Washers: ASTM F-436.
  - E. Anchor Bolts: ASTM F1554 Grade 55 with ASTM A563 Grade A heavy-hex nuts and ASTM A36 plate washers.
  - F. Handhole Frame: ASTM A709 Grade 36 or ASTM A36.
  - G. Handhole Cover: ASTM A1011 Grade 50, 55, 60 or 65.
  - H. Stainless Steel Screws: AISI Type 316.
  - I. Reinforcing Steel: ASTM A615 Grade 60.
  - J. Galvanization: Bolts, nuts and washers: ASTM F2329 All other steel including plate washer: ASTM A123
  - K. Concrete: Class IV (Drilled Shaft) for all environment classifications.
6. Fabrication:
  - A. Welding:
    - a. Specification 460-6.4 and
    - b. AASHTO RFD Specification for Structural Supports for Highway Signs, Luminaires, and Traffic Signals Section 14.4.4.
  - B. Poles:
    - a. Round or 16-sided (Min.)
    - b. Taper pole diameter at 0.14 inches per foot
    - c. Fabricate Pole longitudinal seam welds (2 maximum) with 60 percent minimum penetration or fusion welds except as follows:
      1. Use a full-penetration groove weld within 6 inches of the circumferential tube-to-plate connection and
      2. Use full-penetration groove welds on the female end section of telescopic (i.e., slip type) field splices for a minimum length of one and one-half times the inside diameter of the female section plus 6 inches.
    - d. Pole shaft may be either one or two sections (with telescopic field splice)
    - e. Circumferentially welded pole shafts and laminated pole shafts are not permitted
  - C. Identification Tag: (Submit details for approval)
    - a. 2"x 4" (Max.) aluminum tag
    - b. Locate on the inside of the pole and visible from the handhole
    - c. Secure with 1/8" diameter stainless steel rivets or screws.
    - d. Include the following information on the ID Tag:
      1. Financial Project ID
      2. Pole Type
      3. Pole Height
      4. Manufacturers' Name
      5. Yield Strength (Fy of Steel)
      6. Base Wall Thickness
  - D. Except for Anchor Bolts, bolt hole diameters are bolt diameter plus 1/16" and anchor bolt holes are bolt diameter plus 1/2" (Max) prior to galvanizing.
7. Pole Installation:
  - A. Do not install additional wire access holes (not shown in this Index) with a diameter that exceeds 1 1/2" in diameter.
  - B. Install Anchor Bolts in accordance with Specification 649-5.
  - C. Cable Supports: Electrical Cable Guides and Eyebolts.
    - a. Locate top and bottom cable guides within the pole aligned with each other.
    - b. Position one cable guide 2" below the handhole.
    - c. Position other cable guide 1" directly below the top of the tenon.
    - d. Position Park Stands 2" below the top of the handhole.
  - D. Install Pole with the handhole located away from approaching traffic.
  - E. Install the Pole plumb.
8. Cabinet Installation:
  - A. Splice fiber optic cables in cabinet to preterminated patch panel.
  - B. Furnish and install Surge Protection Devices (SPDs) on all cabling in cabinet.
  - C. Furnish and install secondary SPDs protection on outlets for equipment in cabinet.
  - D. Ensure that all electronic equipment power is protected and conditioned with SPDs.
  - E. Ensure that equipment cabinet is bonded to CCTV pole grounding system.
  - F. Install the pole mounted cabinet with the hinges next to the pole.
  - G. Sizes and types of conduits and inner ducts for network communications between the pull box and cabinet are stated in the Contract Documents.
9. Lowering Device Installation:
  - A. Place the lowering cable that moves within the pole in an interior conduit to prevent it from tangling or interfering with any electrical wire that is in the pole. Ensure that any electrical wire within the pole is routed securely and free from slack.
  - B. Mount lowering device perpendicular to the roadway or as shown in the plans. Position CC TV pole so that the camera can be safely lowered without requiring lane closures.
  - C. Coordinate all lowering device hardware requirements (including Tenon, Tenon mounting plates, parking stands, etc.) with lowering device manufacturer.

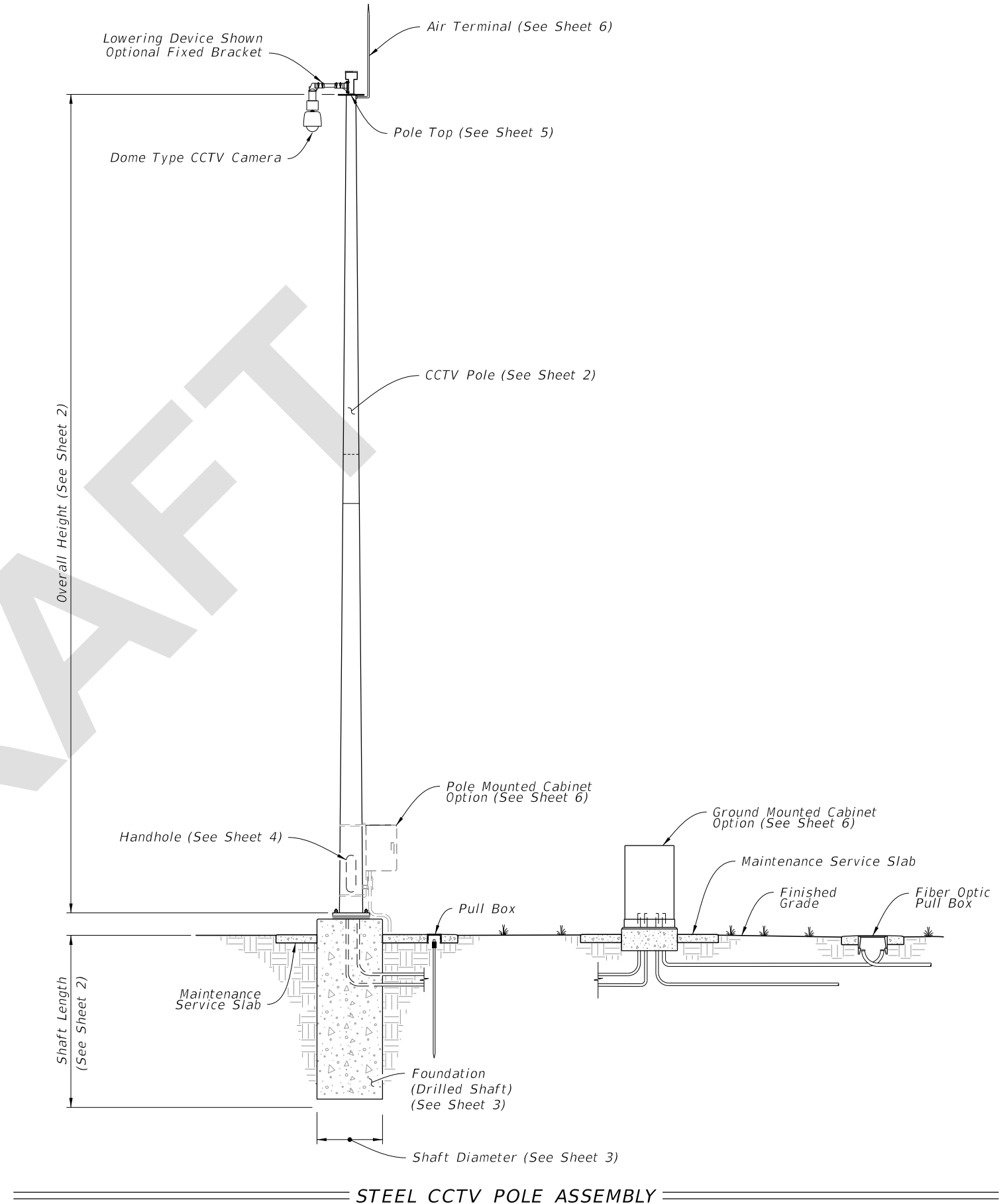

9/11/2022 1:29:18 PM

LAST REVISION 11/01/22	REVISION	DESCRIPTION:	<b>FY 2023-24 STANDARD PLANS</b>	<b>STEEL CCTV POLE</b>	INDEX 649-020	SHEET 1 of 6
---------------------------	----------	--------------	--------------------------------------	------------------------	------------------	-----------------

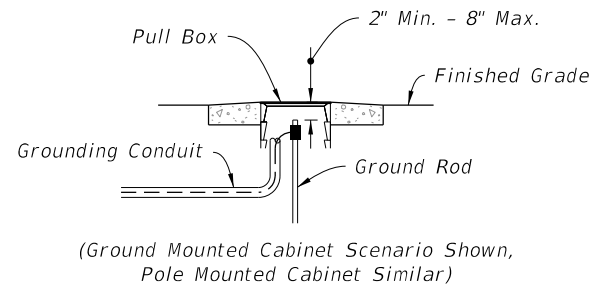
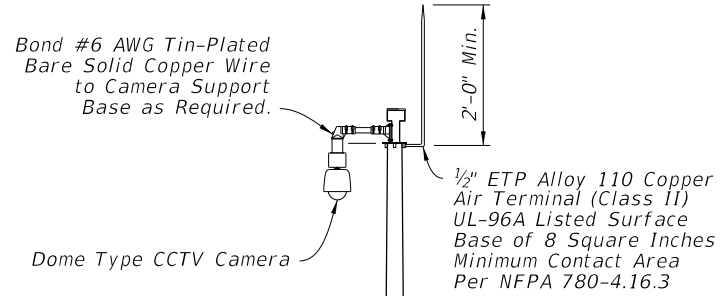

**PULL BOX  
DETAIL "B"**

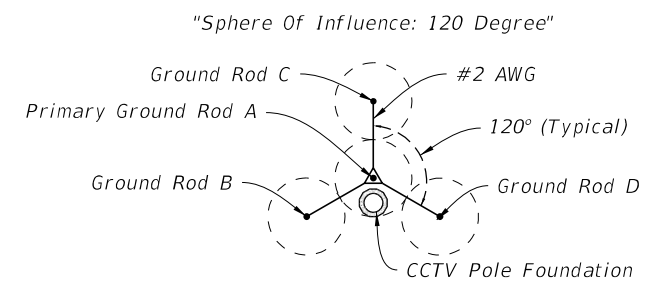

**TYPICAL  
(20' Rods, 40' Spacing)**

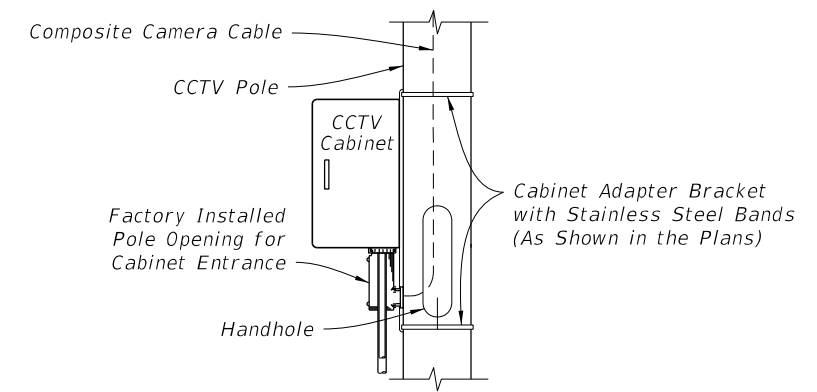

**SIDE VIEW**

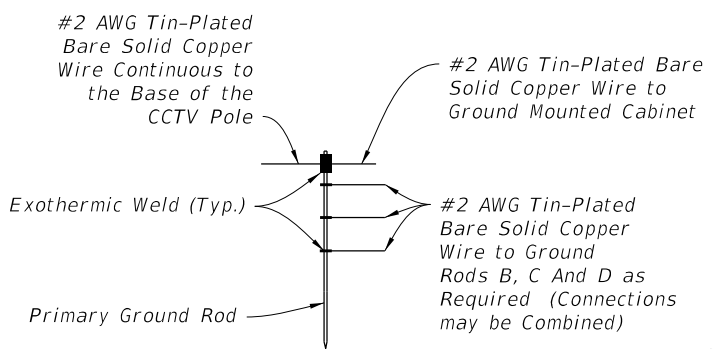

**PRIMARY GROUND ROD ASSEMBLY  
DETAIL "C"**

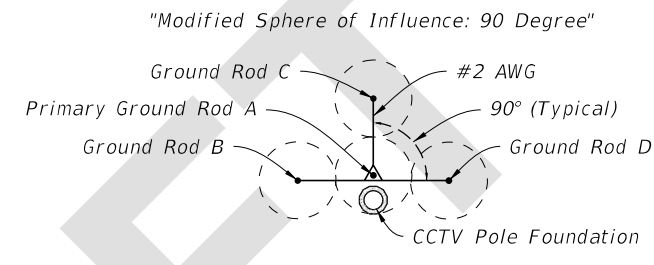

**TYPICAL MODIFIED  
(20' Rods, 40' Spacing)**

**GROUND ROD ARRAY PLACEMENT  
DETAIL "D"**

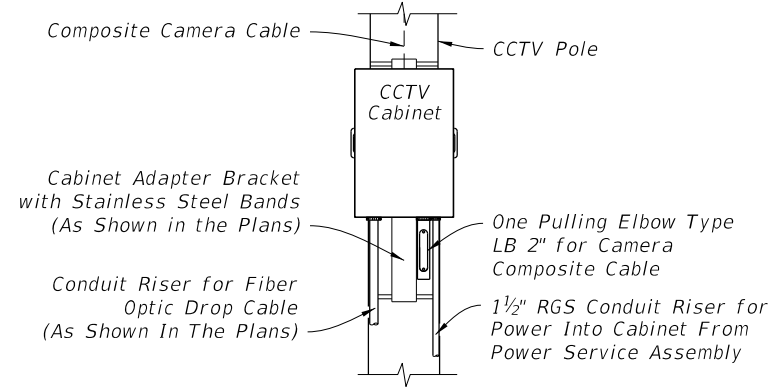

**FRONT VIEW  
DETAIL "E"**

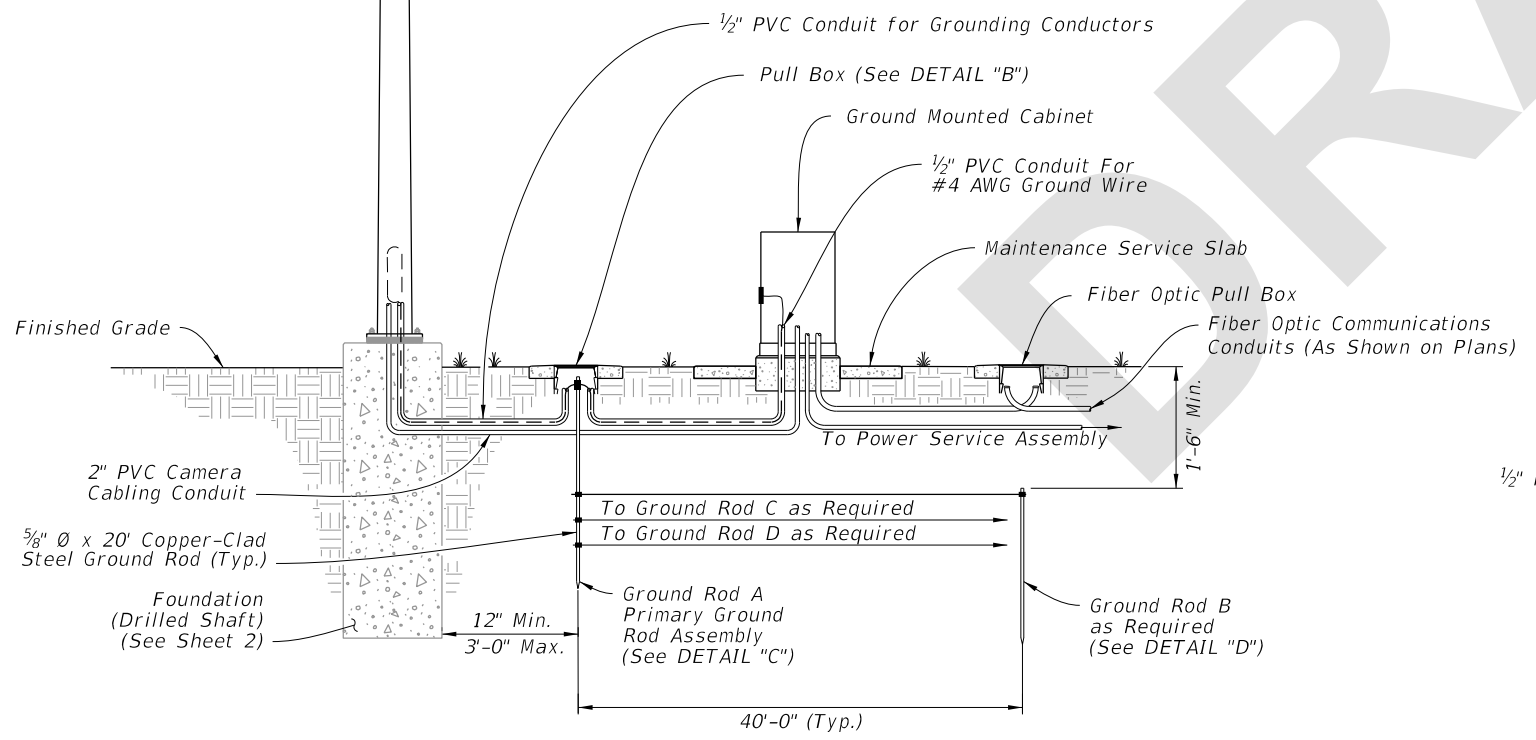

**GROUND MOUNTED CABINET**

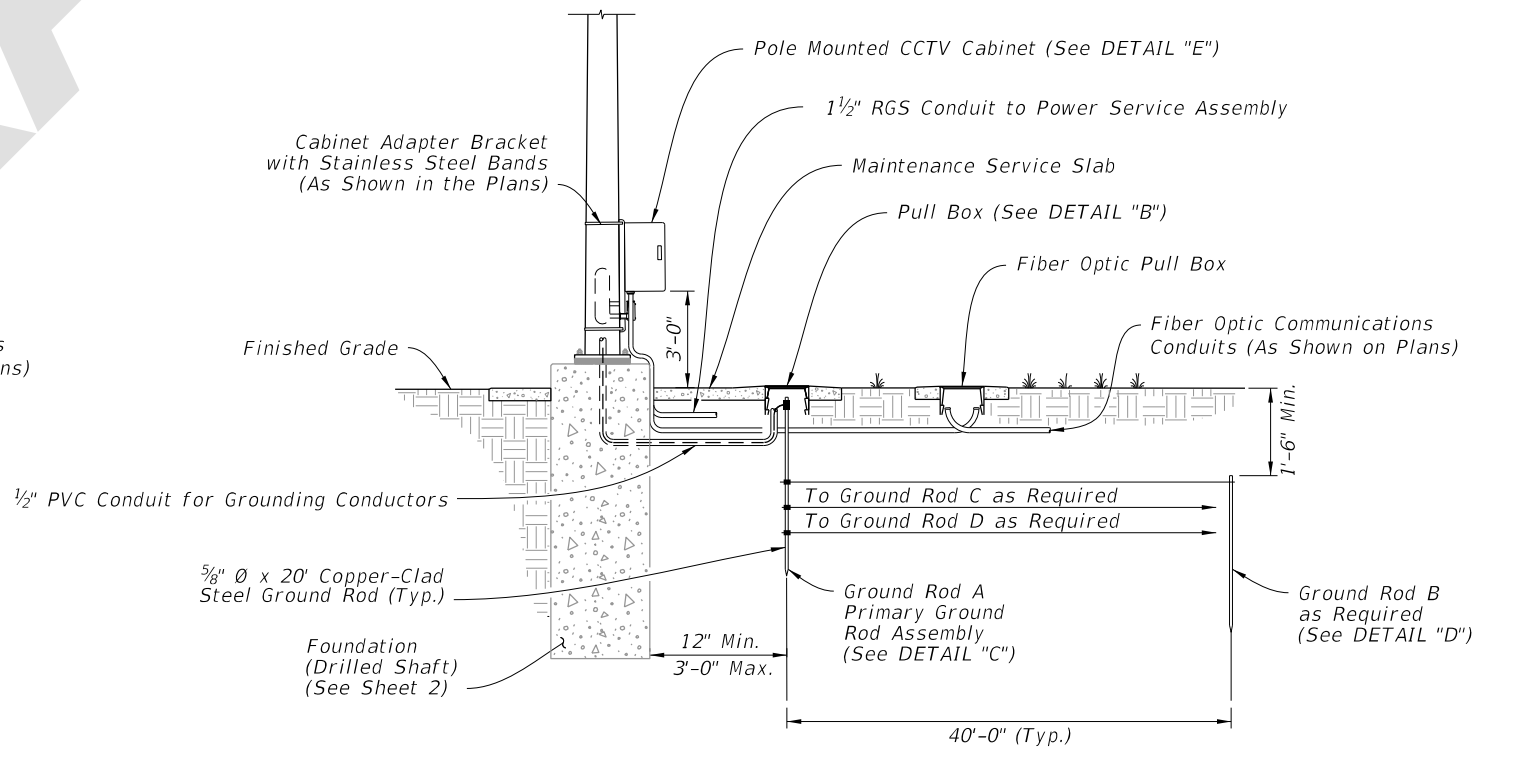

**POLE MOUNTED CABINET**

**STEEL CCTV POLE GROUNDING**

9/11/2022 1:29:20 PM

LAST REVISION 11/01/22	REVISION	DESCRIPTION:	 <b>FY 2023-24 STANDARD PLANS</b>	<b>STEEL CCTV POLE</b>	INDEX 649-020	SHEET 6 of 6
---------------------------	----------	--------------	--	------------------------	------------------	-----------------