ORIGINATION FORM

Proposed Revisions to a Standard Plans Index (Please provide all information — Incomplete forms will be returned)

Contact Information:

Date: November 1, 2019

Originator: Rick Jenkins

Phone: (850) 414-4355

Email: Rick.Jenkins@dot.state.fl.us

Standard Plans:

Index Number: 425-080

Sheet Number (s): ALL

Index Title: Utility Conflict Thru Drainage Structures

Summary of the changes:

Reorganized Index, Added additional Sheet.

Sheet 1: General Notes

Sheet 2: Utility Conflict Condition I and II Details

Commentary / Background:

Reorganized Details and Sheets to declutter Index. Moved information from detail callouts to Notes in order to decrease clutter of the drawing. Moved design information to SPI.

Other Affected Offices / Documents: (Provide name of person contacted)

Yes	No	
<input type="checkbox"/>	<input type="checkbox"/>	Other Standard Plans –
<input type="checkbox"/>	<input type="checkbox"/>	FDOT Design Manual –
<input type="checkbox"/>	<input type="checkbox"/>	Basis of Estimates Manual –
<input type="checkbox"/>	<input type="checkbox"/>	Standard Specifications –
<input type="checkbox"/>	<input type="checkbox"/>	Approved Product List –
<input type="checkbox"/>	<input type="checkbox"/>	Construction –
<input type="checkbox"/>	<input type="checkbox"/>	Maintenance –

Origination Package Includes:

(Email or hand deliver package to Rick Jenkins)

Yes	N/A	
<input checked="" type="checkbox"/>	<input type="checkbox"/>	Redline Mark-ups
<input checked="" type="checkbox"/>	<input type="checkbox"/>	Proposed Standard Plan Instruction (SPI)
<input type="checkbox"/>	<input type="checkbox"/>	Revised SPI
<input type="checkbox"/>	<input type="checkbox"/>	Other Support Documents

Implementation:

- Design Bulletin (Interim)
- DCE Memo
- Program Mgmt. Bulletin
- FY-Standard Plans (Next Release)

Contact the Roadway Design Office for assistance in completing this form

NEW SHEET

ADDED GENERAL NOTES AND OVERVIEW

MOVED TO SHEET 1

NOTES:

1. These details are for construction field expediency to resolve utility conflicts that cannot be remedied by relocation. For conflicts determined during design, use the construction shop drawings for structure details. **SPI**
2. Concrete used in conflict structures shall be as specified in ASTM C478. 4000 psi may be used in lieu of Class I concrete.
3. Maximum opening for pipe shall be the pipe OD plus 6". Mortar used to seal the pipe into the opening will be of such mix that shrinkage will not cause leakage into or out of the structure.
4. If the conflict structure is round or there are multiple inlet or outlet pipes, then the wall section should be reviewed for strength. **SPI**
5. If during construction or the plans design process it is determined that a potable water supply line must pass through a storm drain structure, it must be in compliance with Chapter 62-555.314 (3) F.A.C. and shown on the design or construction plans and submitted to the Florida Department of Environmental Protection (FDEP) Administrator For Drinking Water in the respective FDEP District for review and comment. This index and rule citation provide accepted methods for addressing conflicts when and where they cannot be reasonably avoided. To be submitted along with the plans shall be a justification describing inordinate cost and the impracticality of avoidance. If identified, properly justified, and accomplished in accordance with this index, approval is granted. Upon request, the Utility Agency Owner (UAO) must provide support data on the cost of relocation or adjustment to the FDOT for submittal to the FDEP. See the following web site for District FDEP Drinking Water Contacts: www.dep.state.fl.us/water/drinkingwater/index.htm and click on "Organization" on the menu to the right. **SPI**

DESIGNER'S NOTES:

"Sumped" conflict manholes shall not be used unless the system is hydraulically designed to account for the headloss generated if the sump is completely blocked **SPI**

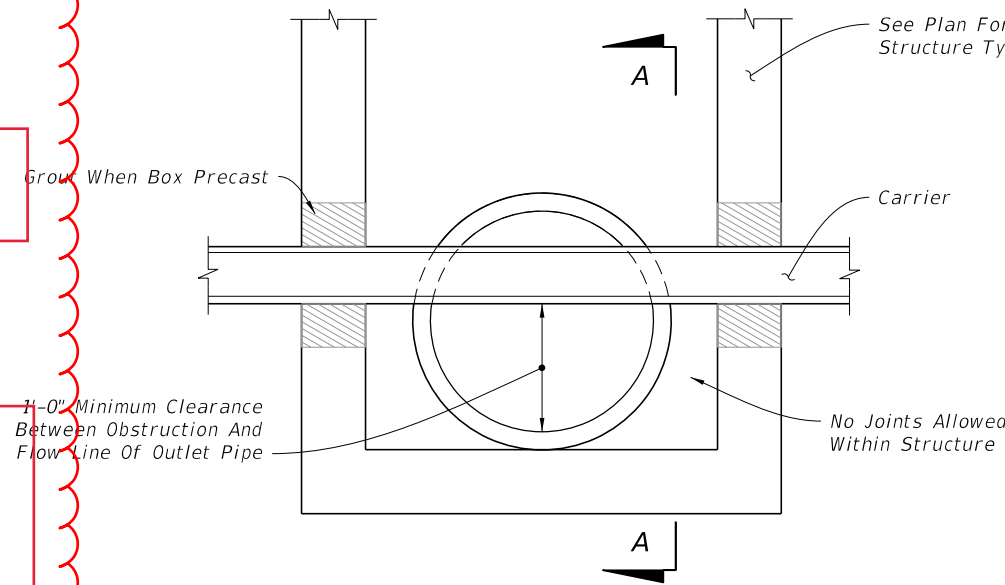

SECTION LONGITUDINAL TO CARRIER PIPE

UTILITY CONFLICT CONDITION I

(Nonpressure Or Nonfluid Carrier Installations)

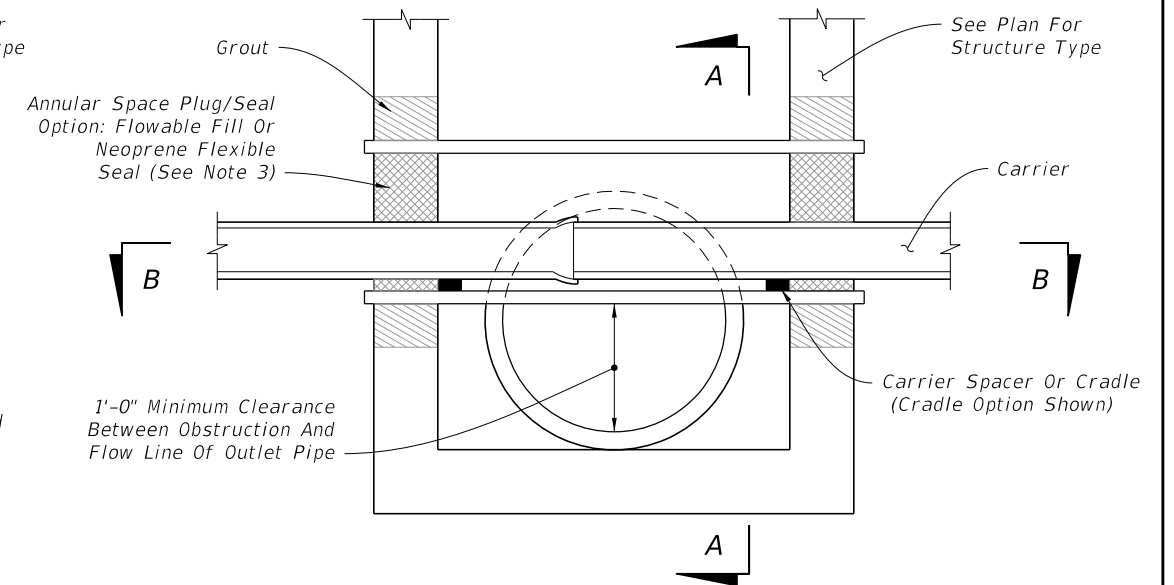

SECTION LONGITUDINAL TO CARRIER PIPE

UTILITY CONFLICT CONDITION II

(Pressure Or Fluid Carrier Installations)

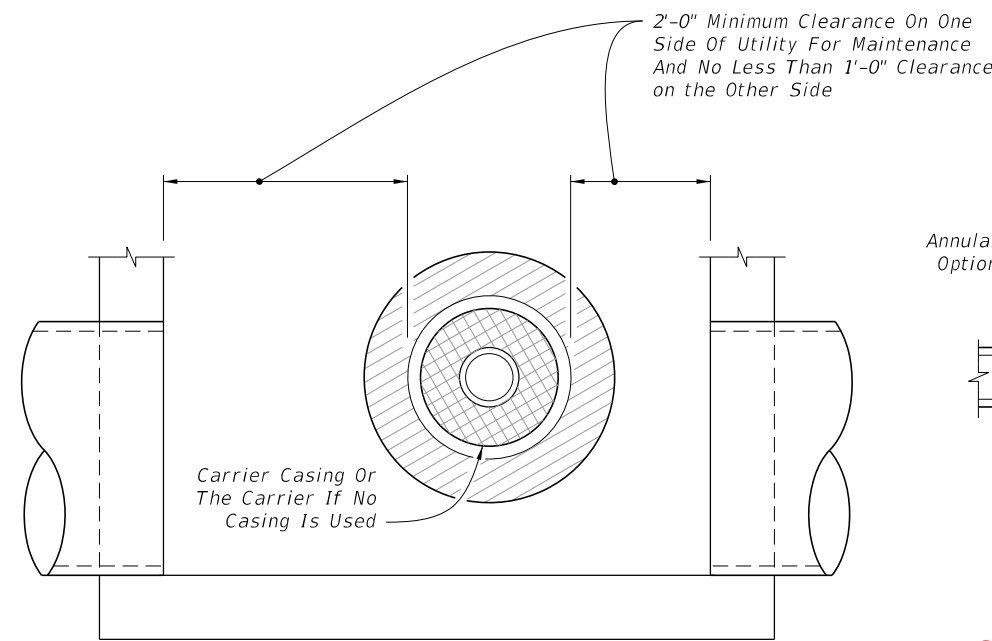

SECTION A-A

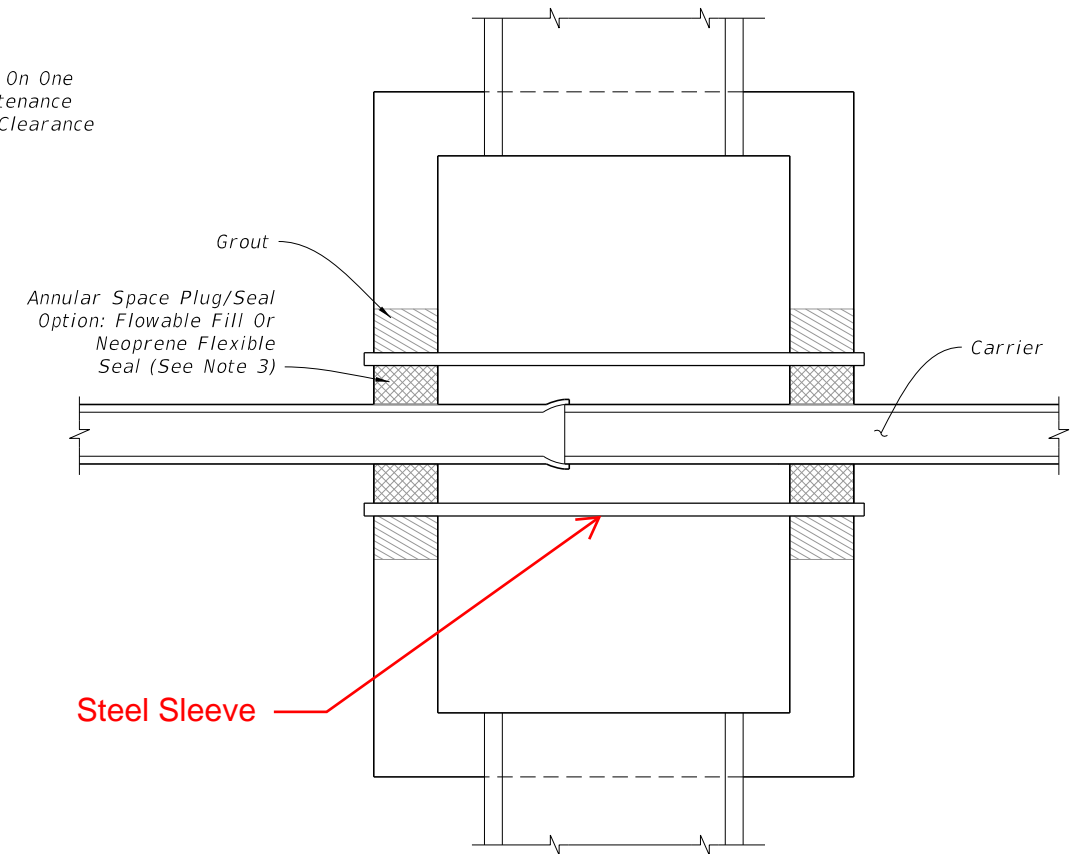

SECTION B-B

CONDITION I AND II DETAILS

UTILITY CONFLICT PIPES THRU STORM DRAIN STRUCTURES

9/18/2018 2:56:44 PM

LAST REVISION	DESCRIPTION:
11/01/17	
11/01/20	

FDOT **FY 2019-20 STANDARD PLANS**

UTILITY CONFLICTS THRU DRAINAGE STRUCTURES

INDEX
425-080

SHEET
1 of 1

GENERAL NOTES:

1. Work with Index 425-001 and Index 425-010.
2. Use Class II Concrete.
3. Maximum opening for pipe shall be the pipe OD plus 6". Mortar used to seal the pipe into the opening will be of such mix that shrinkage will not cause leakage into or out of the structure.
4. If a conflict with a potable water supply line is discovered during construction, submit the following to Florida Department of Environmental Protection (FDEP) District Administrator For Drinking Water prior to constructing conflict structure:
 - a. Plans Revision(s)
 - b. Justification describing inordinate cost and practical avoidance
 - c. Upon request, Utility Agency Owner (UAO) supporting documentation for cost of relocation or adjustment

Potable water supply lines passing through a drainage structure must be in compliance with Chapter 62-555.314(3) F.A.C. This Index and rule citation provide accepted methods for addressing conflicts when they cannot be reasonably avoided.

Website for District FDEP Drinking Water Contacts:
<https://floridadep.gov/water/source-drinking-water/content/organization-drinking-water-program>

TABLE OF CONTENTS:	
Sheet	Description
1	General Notes and Contents
2	Utility Conflict Condition I and II Details

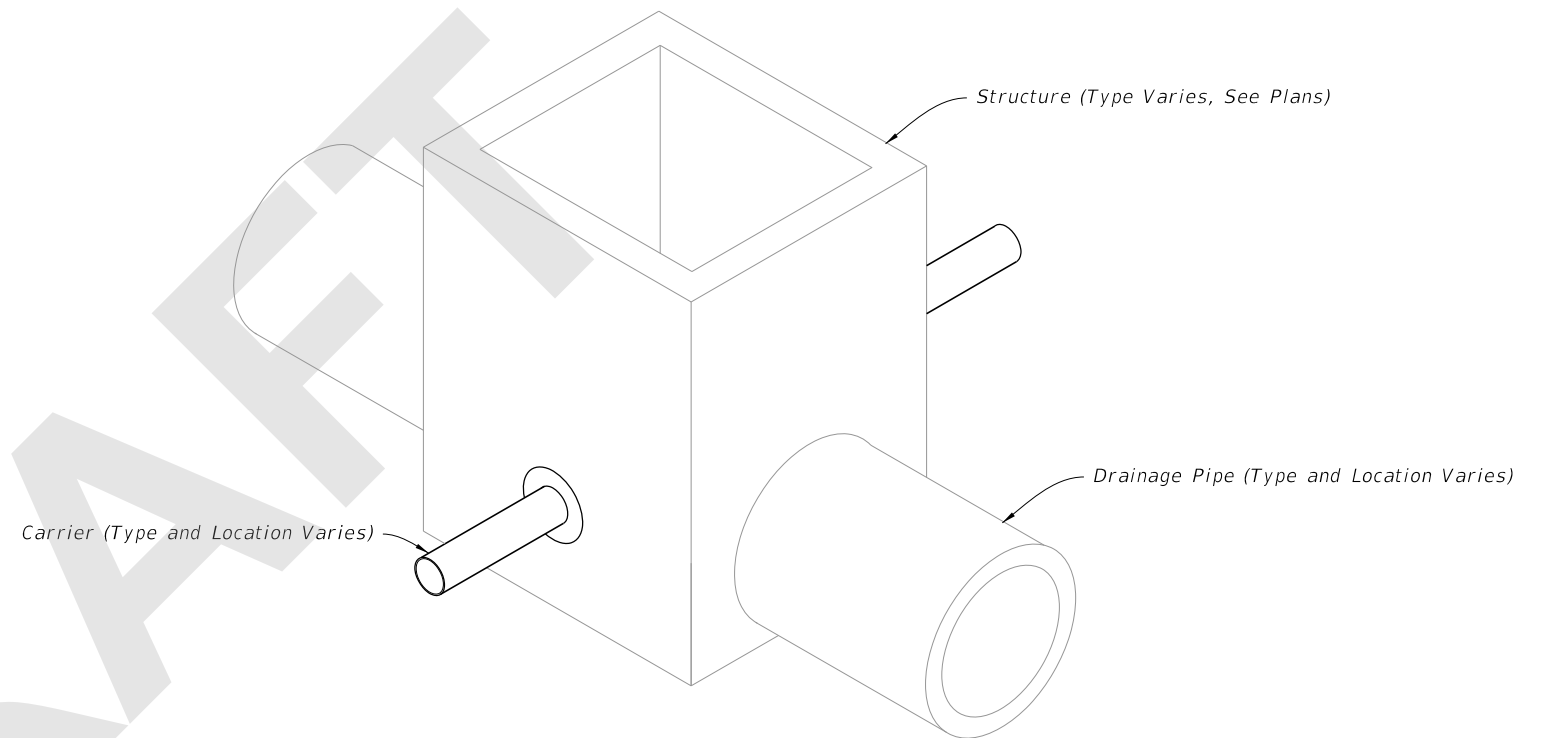

UTILITY CONFLICT
 (Condition I Shown, Condition II Similar)

7/31/2020 7:24:33 AM

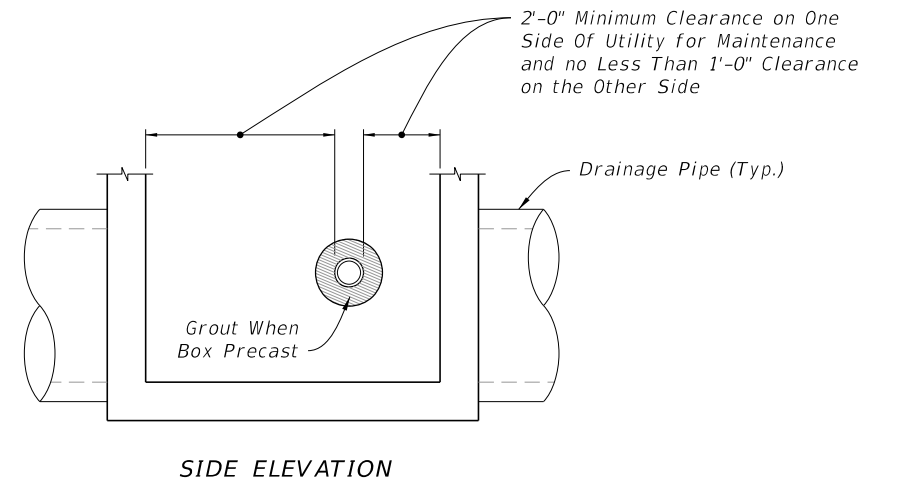
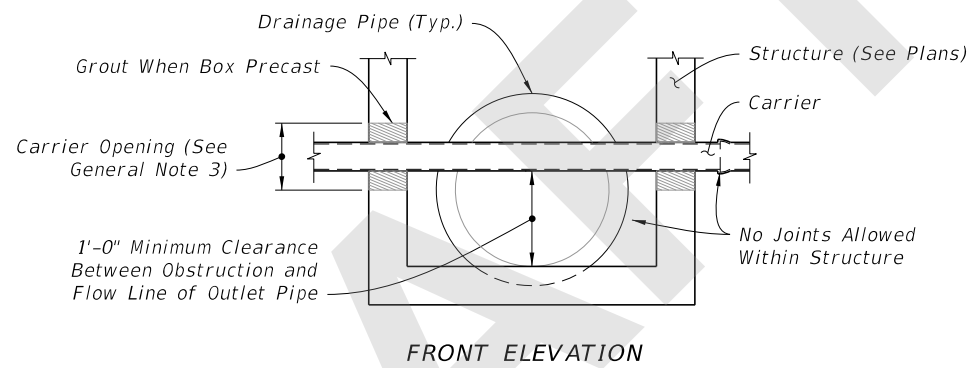
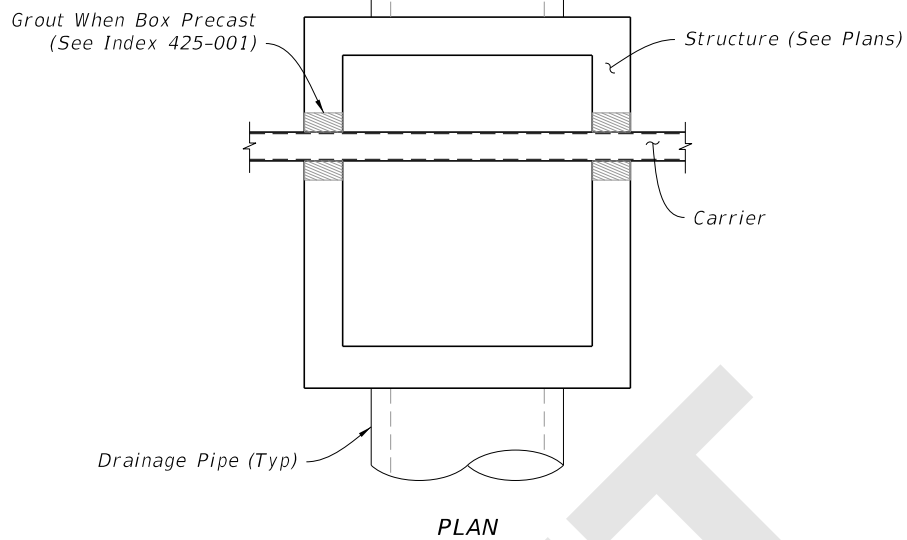

UTILITY CONFLICT CONDITION I
(Nonpressure or Nonfluid Carrier Installations)

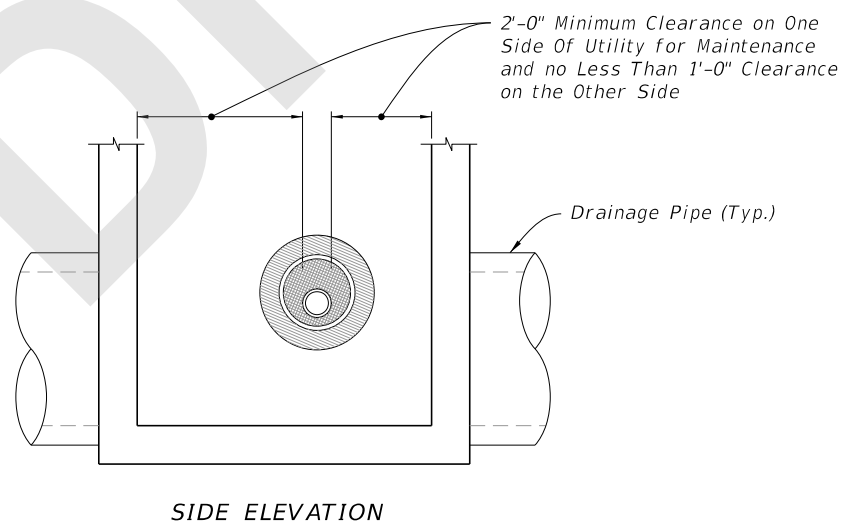
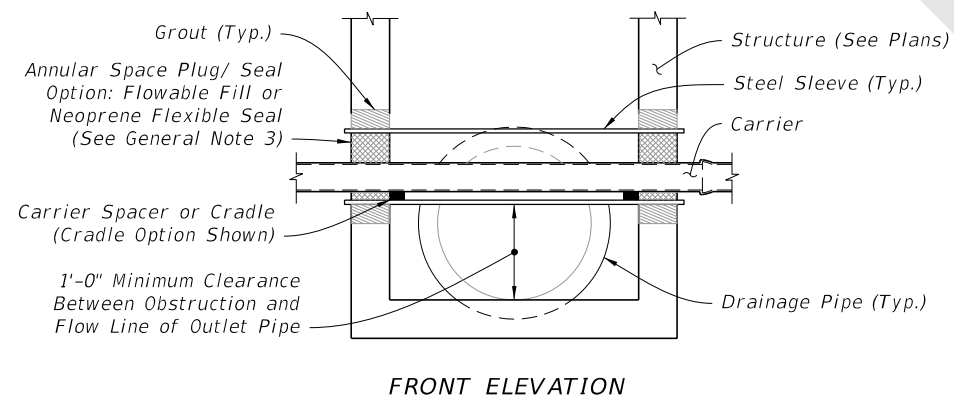
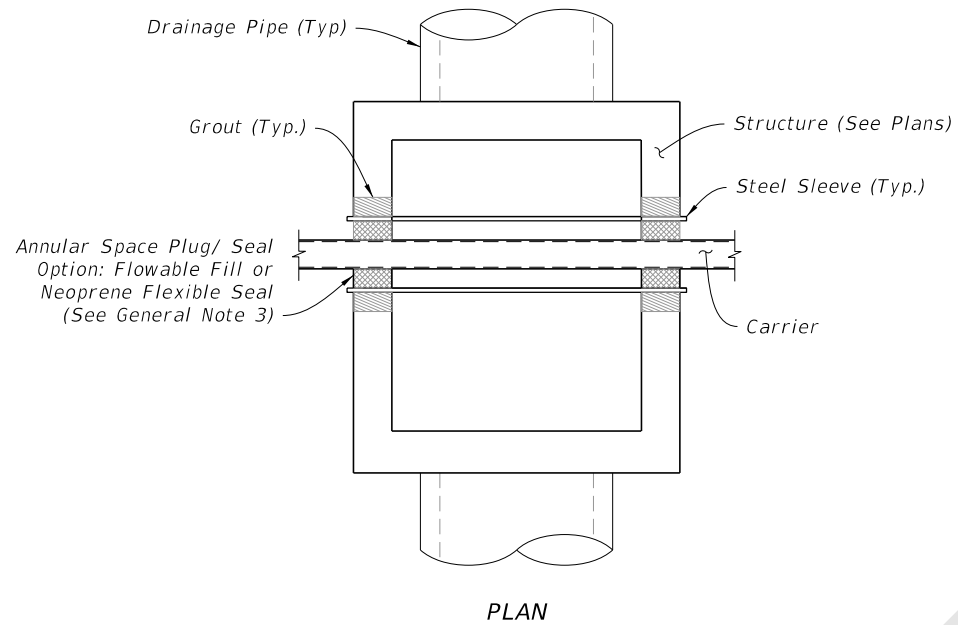

UTILITY CONFLICT CONDITION II
(Pressure or Fluid Carrier Installations)

UTILITY CONFLICT CONDITION I AND II DETAILS

7/31/2020 7:24:37 AM

LAST REVISION 11/01/20	DESCRIPTION:
---------------------------	--------------



FY 2021-22
STANDARD PLANS

UTILITY CONFLICT THRU DRAINAGE STRUCTURES

INDEX
425-080

SHEET
2 of 2