

---

## ORIGINATION FORM

---

Proposed Revisions to a Standard Plans Index  
(Please provide all information — Incomplete forms will be returned)

**Contact Information:**

Date: February 13, 2020  
Originator: Tim Holley  
Phone: (850) 414-4117  
Email: Tim.Holley@dot.state.fl.us

**Standard Plans:**

Index Number: 425-031  
Sheet Number (s): ALL  
Index Title: Adjacent Barrier Inlet

**Summary of the changes:**

Reorganized Index, Added additional Sheets.  
Sheet 1: General Notes  
Sheet 2: Dimensional, Reinforcement, and Steel Grate Details  
Sheet 3: Inlet Collar Dimensional, Reinforcement, and Backwall Plate Details  
Sheet 4: Shoulder Pavement Wrap, Barrier Type Examples, and Structure Bottoms

**Commentary / Background:**

Reorganized Details and Sheets to declutter Index. Moved information from detail callouts to Notes in order to decrease clutter of the drawing. Moved design information to SPI.

**Other Affected Offices / Documents:** (Provide name of person contacted)

Yes	No	
<input type="checkbox"/>	<input type="checkbox"/>	Other Standard Plans –
<input type="checkbox"/>	<input type="checkbox"/>	FDOT Design Manual –
<input type="checkbox"/>	<input type="checkbox"/>	Basis of Estimates Manual –
<input type="checkbox"/>	<input type="checkbox"/>	Standard Specifications –
<input type="checkbox"/>	<input type="checkbox"/>	Approved Product List –
<input type="checkbox"/>	<input type="checkbox"/>	Construction –
<input type="checkbox"/>	<input type="checkbox"/>	Maintenance –

**Origination Package Includes:**

(Email or hand deliver package to Rick Jenkins)

Yes	N/A	
<input checked="" type="checkbox"/>	<input type="checkbox"/>	Redline Mark-ups
<input type="checkbox"/>	<input type="checkbox"/>	Proposed Standard Plan Instruction (SPI)
<input type="checkbox"/>	<input type="checkbox"/>	Revised SPI
<input type="checkbox"/>	<input type="checkbox"/>	Other Support Documents

**Implementation:**

<input type="checkbox"/>	Design Bulletin (Interim)
<input type="checkbox"/>	DCE Memo
<input type="checkbox"/>	Program Mgmt. Bulletin
<input checked="" type="checkbox"/>	FY-Standard Plans (Next Release)

---

Contact the Roadway Design Office for assistance in completing this form

---

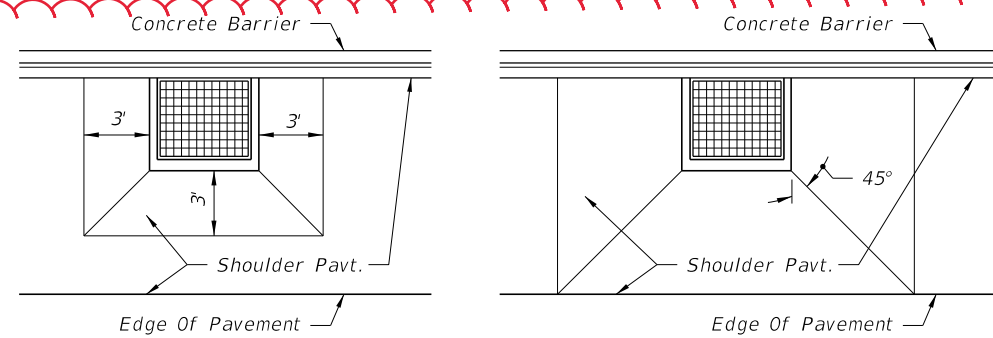

LOW SIDE SUPERELEVATION PAVEMENT WARP FOR SHOULDERS IN SUPERELEVATION

HIGH SIDE TRANSITION PAVEMENT WARP FOR SHOULDERS IN SUPERELEVATION

Joint And Bond Breaker:  
 Cast-In-Place Inlets:  
 One layer ASTM D6380 Class S, Type III Organic Felt bond breaker between inlet and barrier, including footings.  
 Precast Inlets:  
 Joint width 1" max. Seal with backer rod and Department-approved pavement joint sealant. See Section BB For Other Barrier Shape.

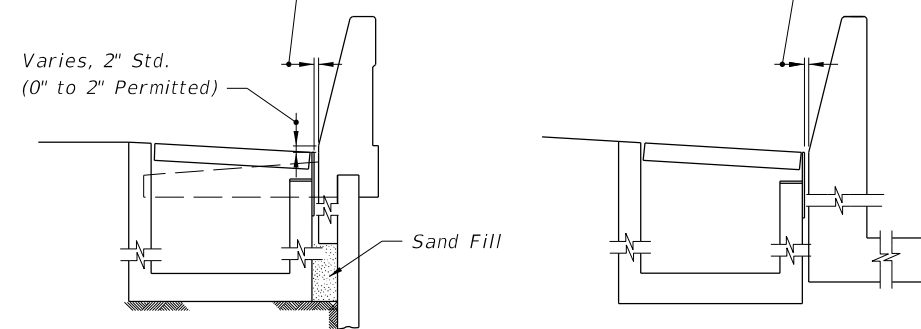

BARRIER WITH JUNCTION SLAB AND WALL COPING

BARRIER WITH STEM AND FOOTING

INLET SECTIONS - EXAMPLE BARRIER TYPES

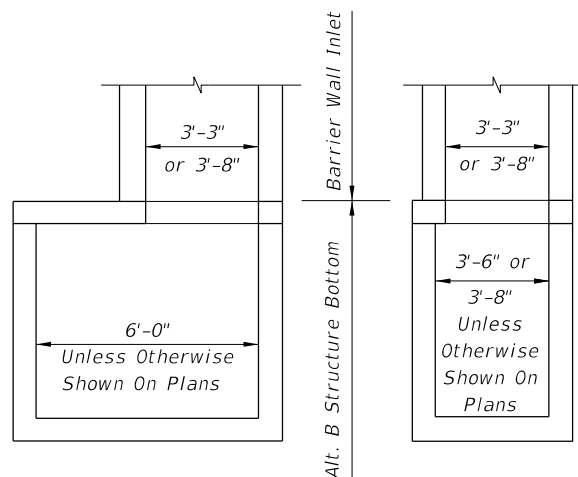

Note: Alt. B Structure Bottom Only. See Index 425-010

INLET WITH STRUCTURE BOTTOM

SHEET 2

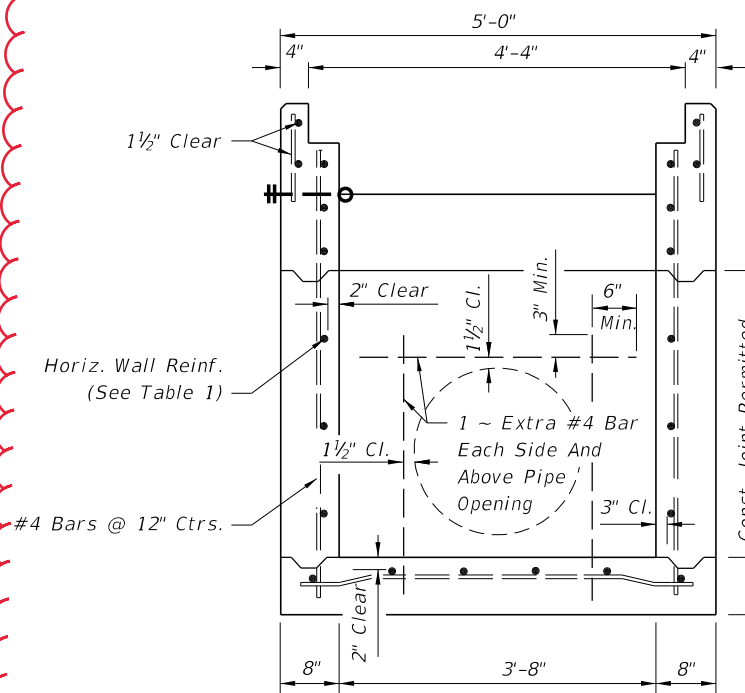

SECTION A-A (WITHOUT GRATE)  
 (Pipe Opening Shown)

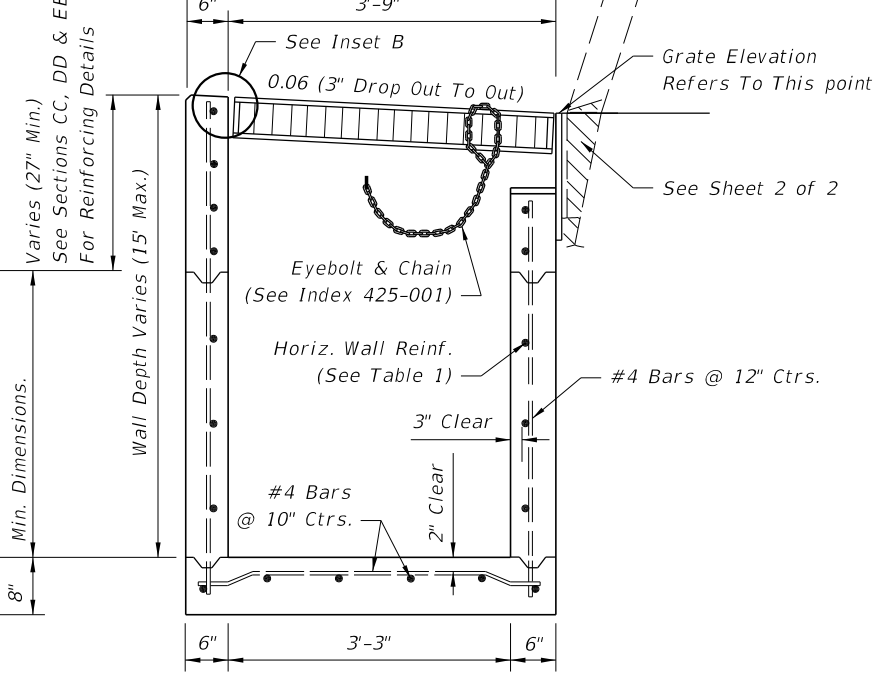

SECTION B-B  
 (Pipe Opening Not Shown)

GENERAL NOTES:

- Where called for in the Plans, use this inlet in conjunction with median or shoulder barrier per Index 521-001 or a barrier with junction slab and wall coping per Index 521-610. The inlet is suitable for bicycle and occasional pedestrian traffic, with roller bar installation (see INSET B), but should not be placed in a designated pedestrian travel way. **SPI**
- Inlets located in embankments constructed with earth anchored retaining wall shall be designed with minimum depths to reduce adverse impact on the anchorage system. Runs of pipe parallel to and near anchored wall shall be avoided wherever practical. Special coordination must be exercised during the design and construction of storm water systems within anchored wall systems.
- Inlet bottoms and/or tops may be either precast or cast-in-place. Whether cast as a single unit or as multiple segments, and whether precast or cast-in-place, the upper 2'-3" of the inlet shall be reinforced in accordance with sections CC, DD and EE.
- All exposed edges and corners shall be 3/4" chamfer or tooled to 1/4" radius.
- When Alternate C grate is specified in the plans, the grate is to be hot dip galvanized after fabrication. Field installation of the filler bar called for in Inset B will not be permitted, thereby requiring tolerance adjustment during fabrication and/or casting, or, matching grate to structure prior to galvanizing.
- All reinforcing is Grade 60 bars. See Index 425-001 for equivalent area of welded wire fabric.
- All dimensions are for both precast and cast-in-place inlets unless otherwise noted.
- For supplemental details see Indexes 425-001 and 425-010.
- Inlets to be paid for under the contract unit for Inlets (Concrete Barrier), Ea.

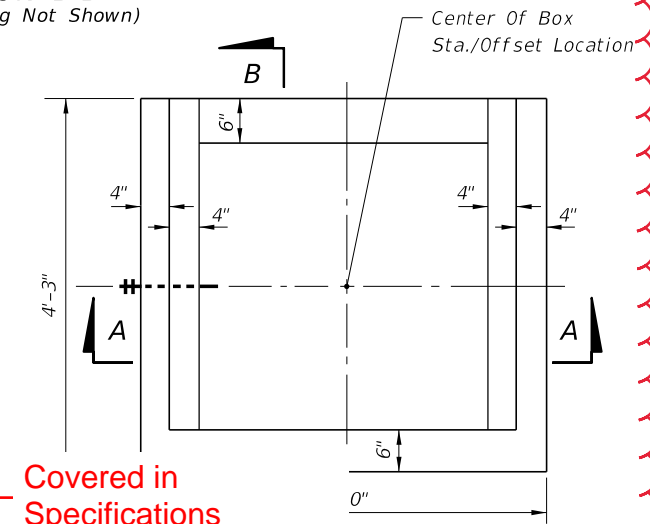

TOP VIEW (WITHOUT GRATE)

TABLE 1: HORIZONTAL WALL REINFORCING SCHEDULE

WALL DEPTH	SCHEDULE	AREA (in. <sup>2</sup> /ft.)	MAX. SPACING	
			BARS	WWR
0'-5'	A12	0.20	12"	8"
5'-10'	A6	0.20	6"	5"
10'-15'	A4	0.20	4"	3"
10'-15'	B5.5	0.24	5 1/2"	5"

SHEET 4

10/14/2019 9:10:14 AM

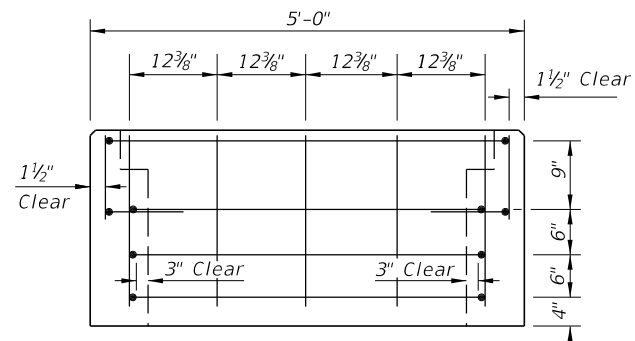

SECTION C-C

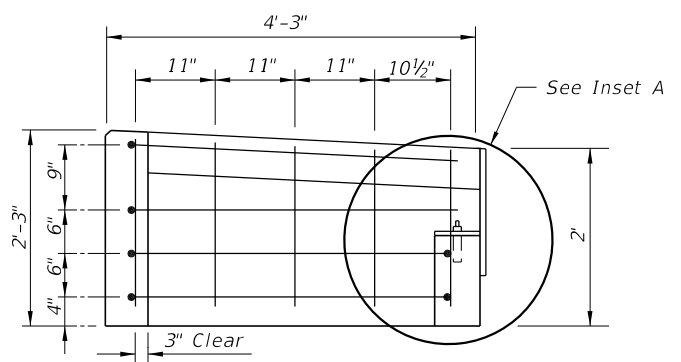

SECTION D-D

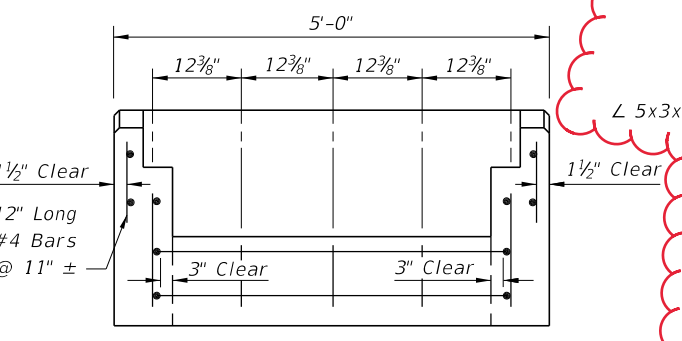

SECTION E-E

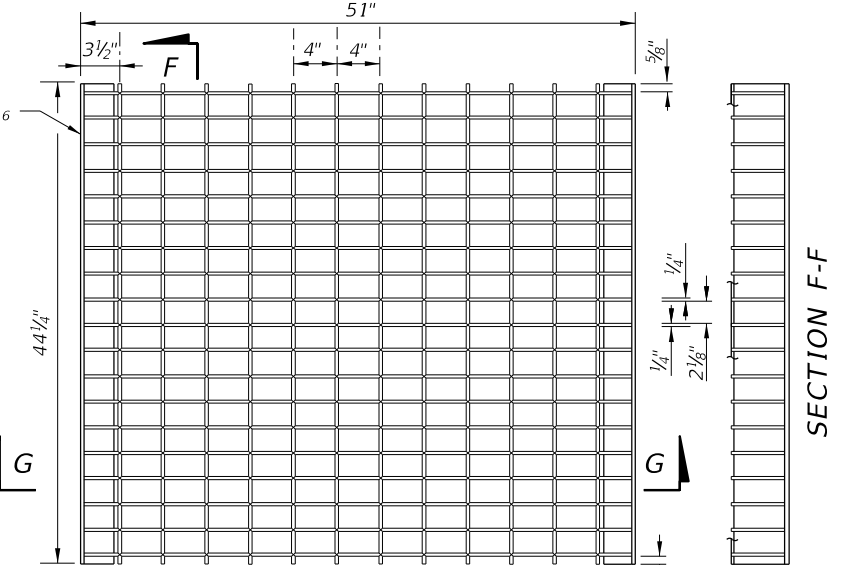

TOP VIEW  
Main Bars: 5"x1/4"  
Cross Bars: Either 3/8"Ø Electroforged or 1/2"Ø Welded

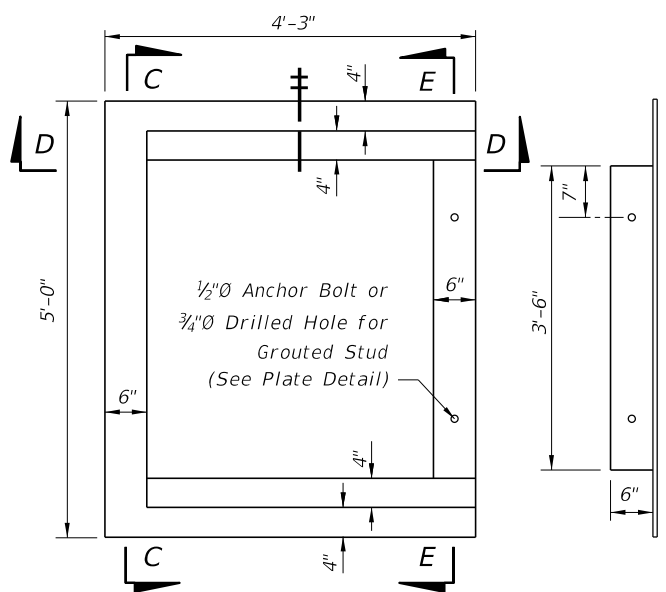

TOP VIEW OF INLET WITHOUT GRATE

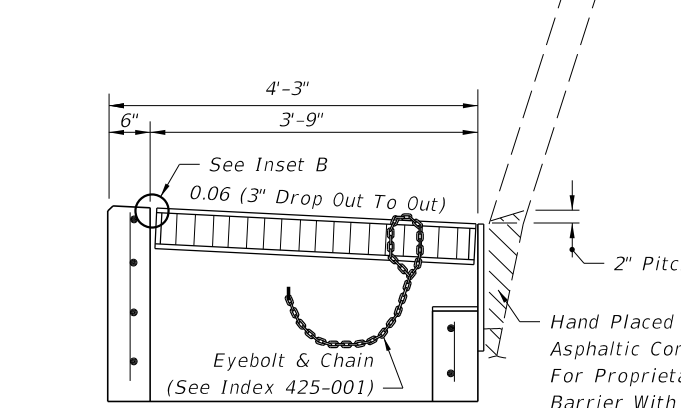

TRANSVERSE SECTION WITH GRATE & PLATE

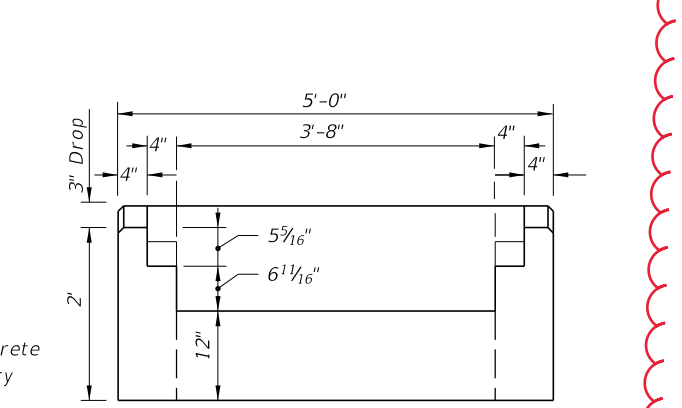

BACK VIEW WITHOUT BACK PLATE

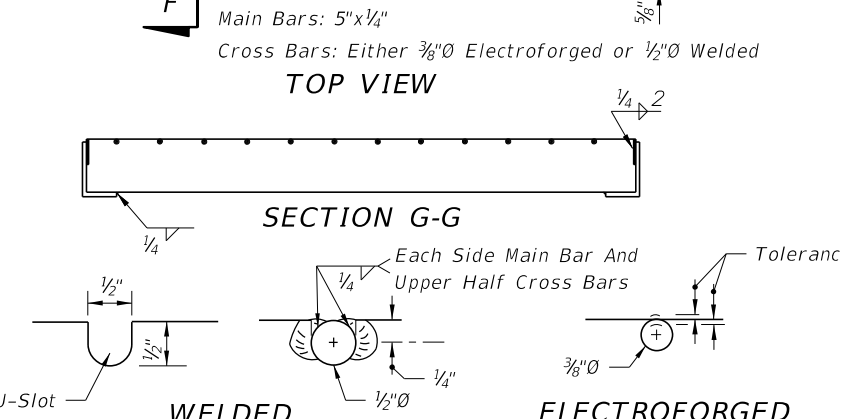

SECTION G-G  
WELDED  
ELECTROFORGED  
CROSS BAR OPTIONS  
STEEL GRATE

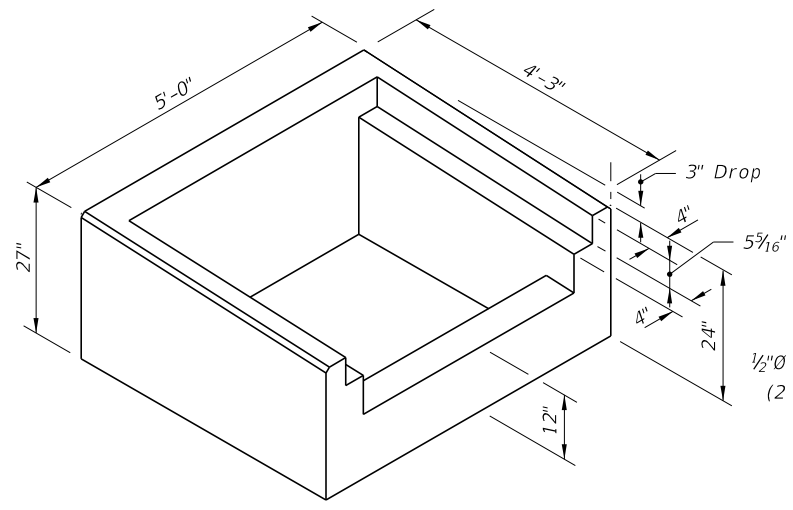

PICTORIAL VIEW OF INLET COLLAR

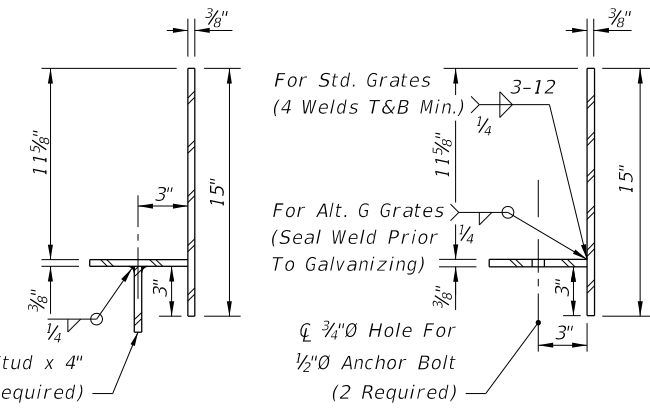

TRANSVERSE SECTIONS THRU BACKWALL PLATE

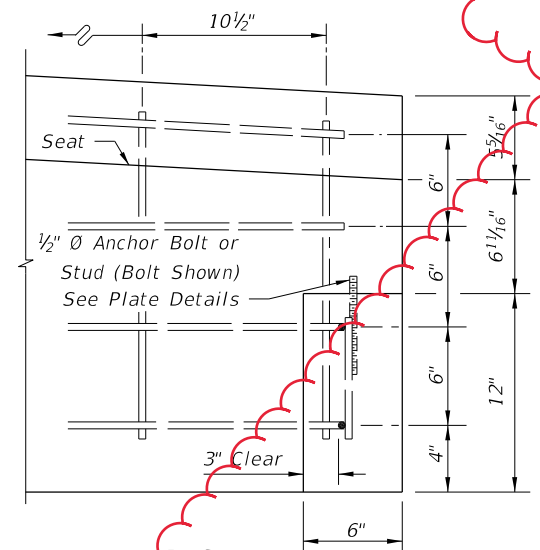

INSET A

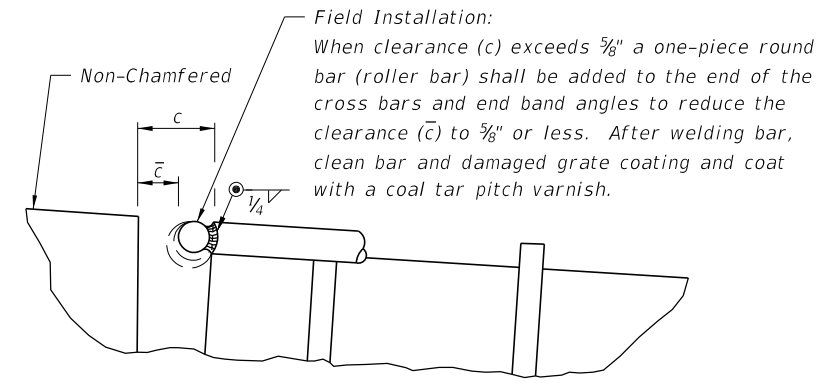

INSET B  
(See Sheet 1, General Note 1)

NOTES

- All reinforcing steel bars shown are #4 bars.
- Anchor bolts shall be either ASTM A307 hex head bolts cast-in-place, or ASTM A36 or F1554 (Grade 36) galvanized fully threaded rod, adhesive bonded anchors installed in accordance with Specification Section 416. Bolts or rods shall be 6" long (4" min. embedment) with one heavy hex head nut (ASTM 194 or A563) and one flat washer (ASTM F436) each. All anchor bolts, nuts and washers shall be hot-dip galvanized.

SHEET 3

SHEET 2

10/14/2019 9:10:14 AM

LAST REVISION 11/01/19	DESCRIPTION:		FY 2020-21 STANDARD PLANS	ADJACENT BARRIER INLET		INDEX 425-031	SHEET 2 of 2
REVISION							

**GENERAL NOTES:**

1. Work this Index with Index 425-001 and Index 425-010.
2. When called for in the Plans, use this inlet in conjunction with median or shoulder barrier per Index 521-001 or a barrier with junction slab and wall coping per Index 521-610.
3. Reinforce the upper 2'-3" of the inlet in accordance with sections CC, DD, and EE regardless of construction method.
4. Chamfer exposed edges and corners to  $\frac{3}{4}$ " or tool to  $\frac{1}{4}$ " radius.
5. Field installation of a roller bar will not be permitted. Adjust tolerance during fabrication or casting, or, match grate to structure prior to galvanizing.
6. Use Grade 60, #4 bars for reinforcing steel. See Index 425-001 for equivalent area of welded wire fabric.
7. Dimensions are for both precast and cast-in-place inlets unless otherwise noted.
8. Anchor bolts: Use either ASTM A307 hex head bolts cast-in-place, or ASTM A36 or F1554 (Grade 36) galvanized fully threaded rod, adhesive bonded anchors installed in accordance with Specification 416. Rods must be a minimum of 6" long with 4" minimum embedment with one ASTM 194 or A563 heavy hex head nut and one ASTM F436 flat washer each. Hot-dip galvanize anchor bolts, nuts, and washers.
9. Reduce Cross Slope: Use a flatter cross slope as required to match adjacent grading per the Plans. Reduce vertical dimensions and bar spacing as needed to maintain concrete cover as shown.

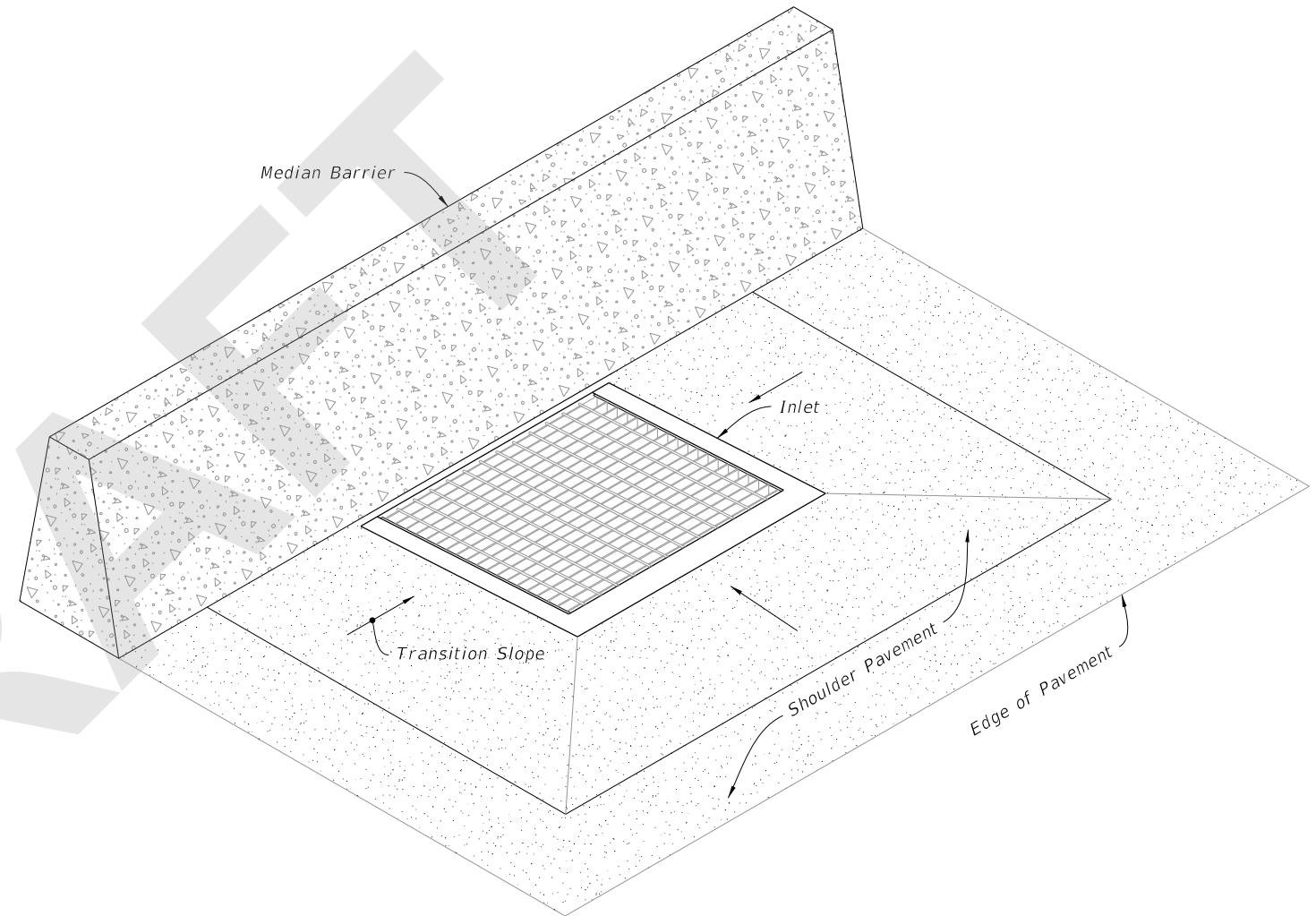
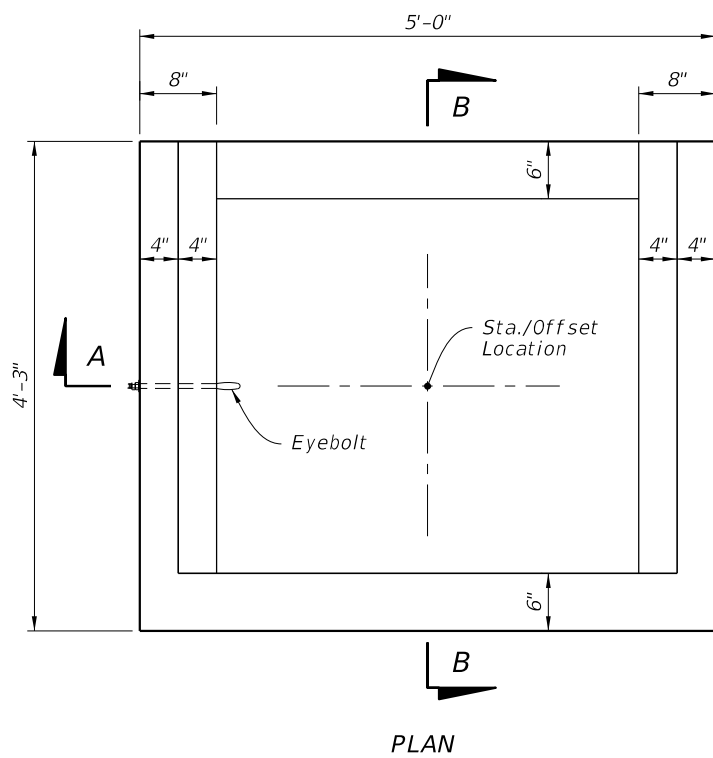

**TABLE OF CONTENTS:**

Sheet	Description
1	General Notes and Contents
2	Dimensional, Reinforcement, and Steel Grate Details
3	Inlet Collar Dimensional, Reinforcement, and Backwall Plate Details
4	Shoulder Pavement Wrap, Barrier Type Examples, and Structure Bottoms

**ADJACENT BARRIER INLET**  
(Shoulder Barrier Similar)

9/1/2020 9:27:05 AM



PLAN

**NOTES:**

1. See Sections E-E, F-F, and G-G on Sheet 3 for reinforcing details.
2. Construction joints permitted between these limits. See Index 425-001 for minimum dimensions.
3. Field Installation: When clearance (C) exceeds  $\frac{5}{8}$ " weld a one-piece round bar (roller bar) to the end of the cross bars and end band angles to reduce the clearance ( $\bar{C}$ ) to  $\frac{5}{8}$ " or less. After welding the bar, clean bar and damaged grate coating and coat with a coal tar pitch varnish.

**TABLE 1: HORIZONTAL WALL REINFORCING SCHEDULE**

WALL DEPTH	SCHEDULE	AREA (in. <sup>2</sup> /ft.)	MAX. SPACING	
			BARS	WWR
0'-5'	A12	0.20	12"	8"
5'-10'	A6	0.20	6"	5"
10'-15'	A4	0.20	4"	3"
10'-15'	B5.5	0.24	5½"	5"

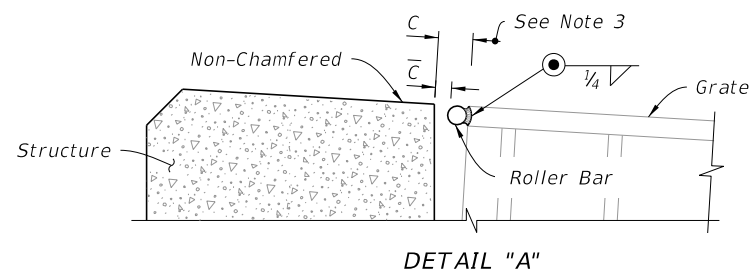

DETAIL "A"

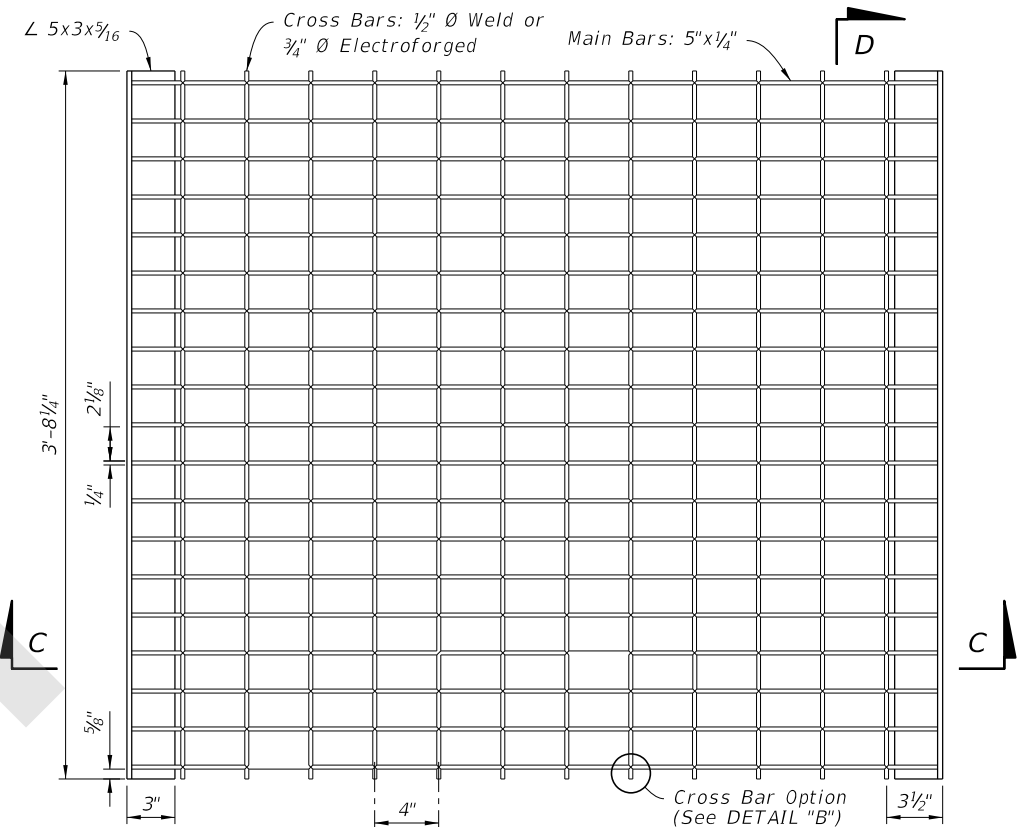

PLAN

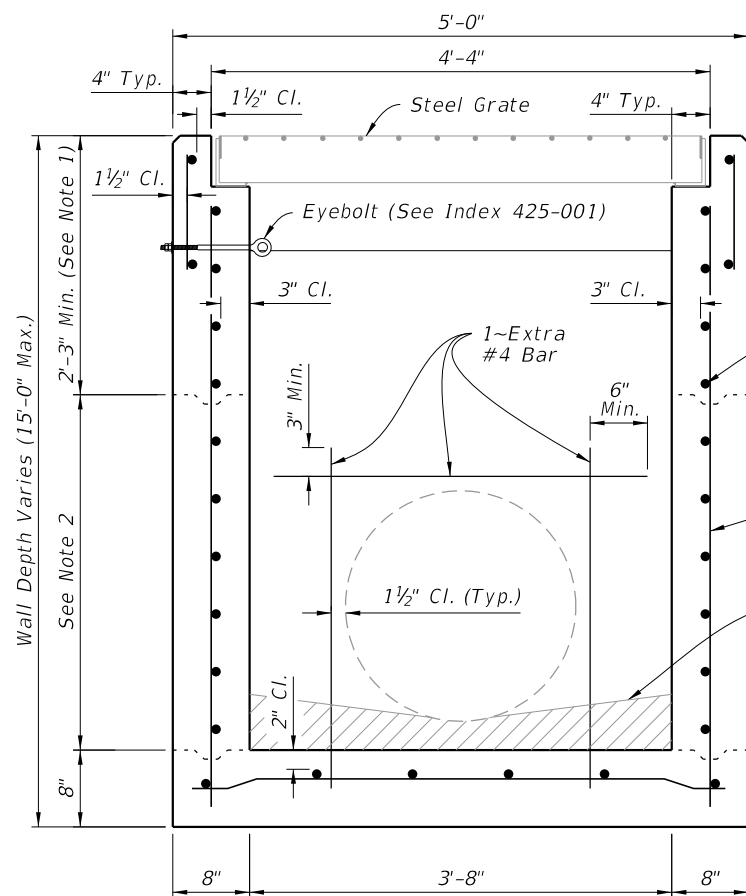

SECTION A-A  
(Pipe Opening Shown)

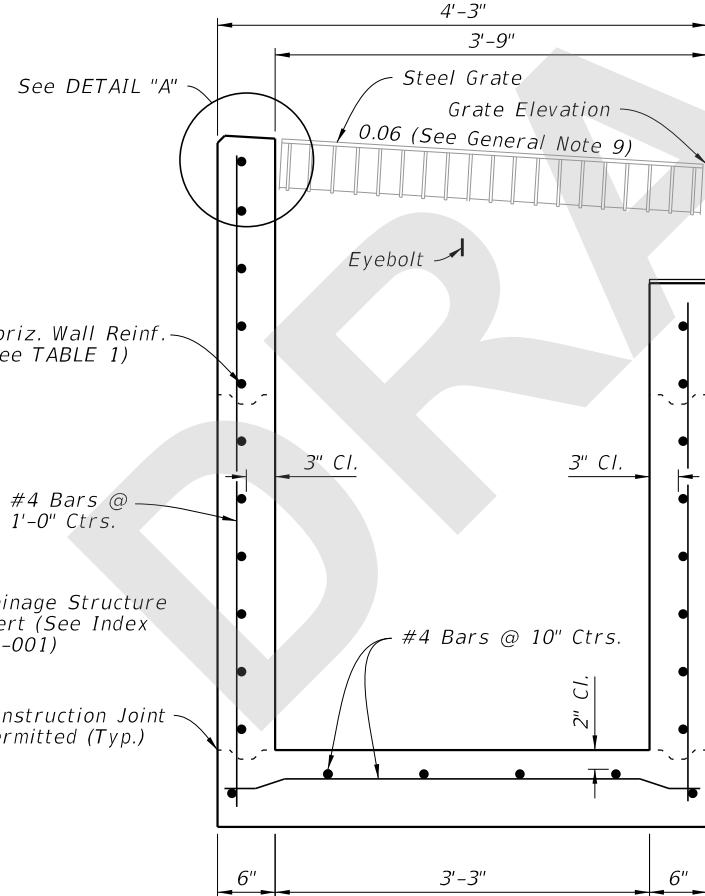

SECTION B-B  
(Pipe Opening Not Shown)

**DIMENSIONAL AND REINFORCEMENT**

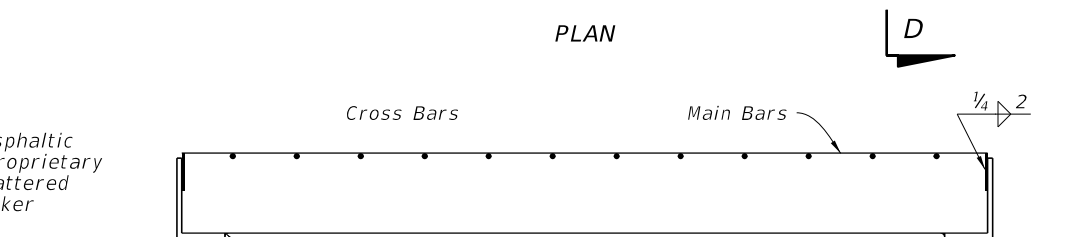

SECTION C-C



SECTION D-D

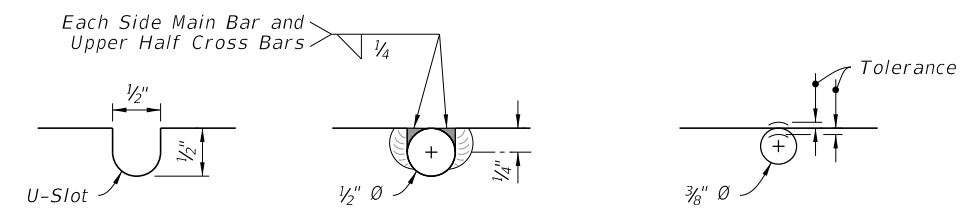

DETAIL "B"

**STEEL GRATE**

**DIMENSIONAL, REINFORCEMENT, AND STEEL GRATE DETAILS**

9/1/2020 9:27:13 AM

LAST REVISION	DESCRIPTION:
11/01/20	



FY 2021-22  
STANDARD PLANS

ADJACENT BARRIER INLET

INDEX  
425-031

SHEET  
2 of 4



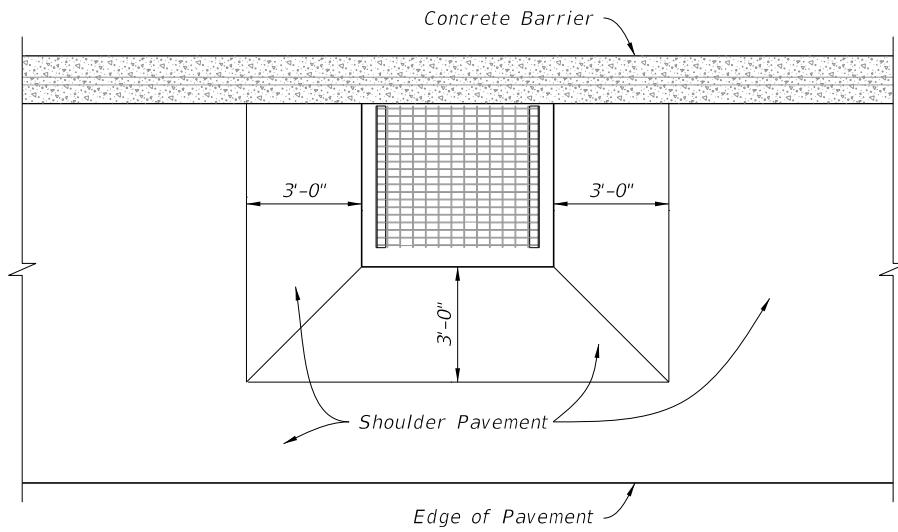

LOW SIDE SUPERELEVATION

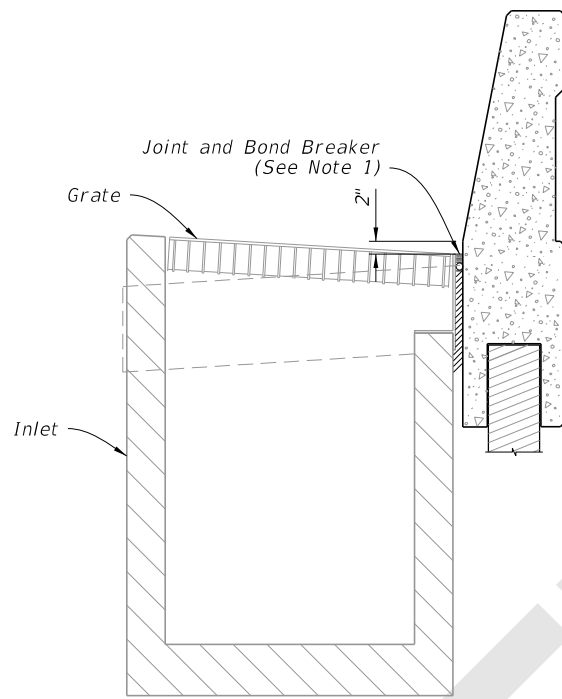

JUNCTION SLAB AND WALL COPING

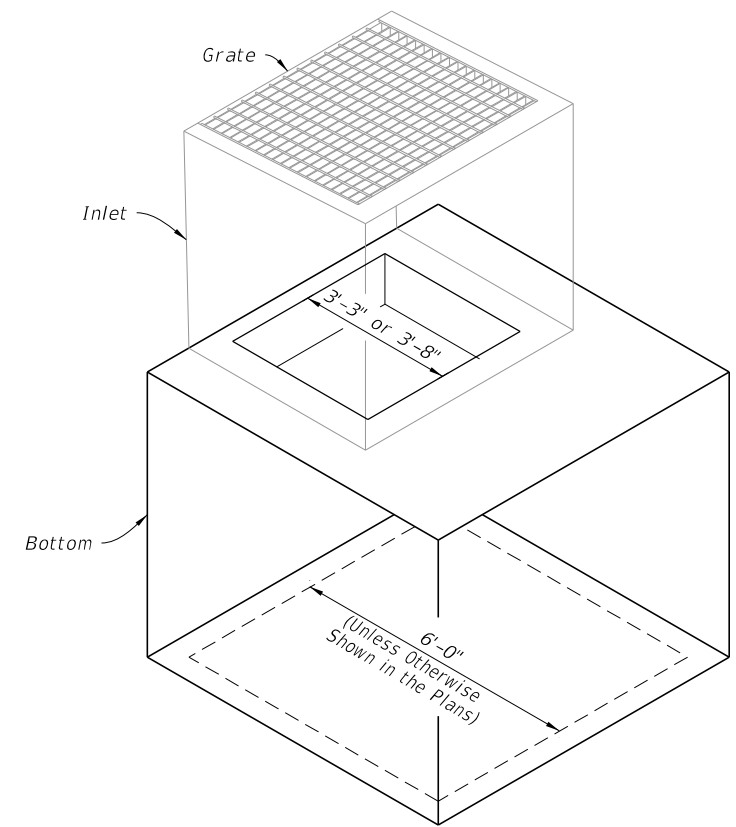

ALTERNATE B STRUCTURE BOTTOM

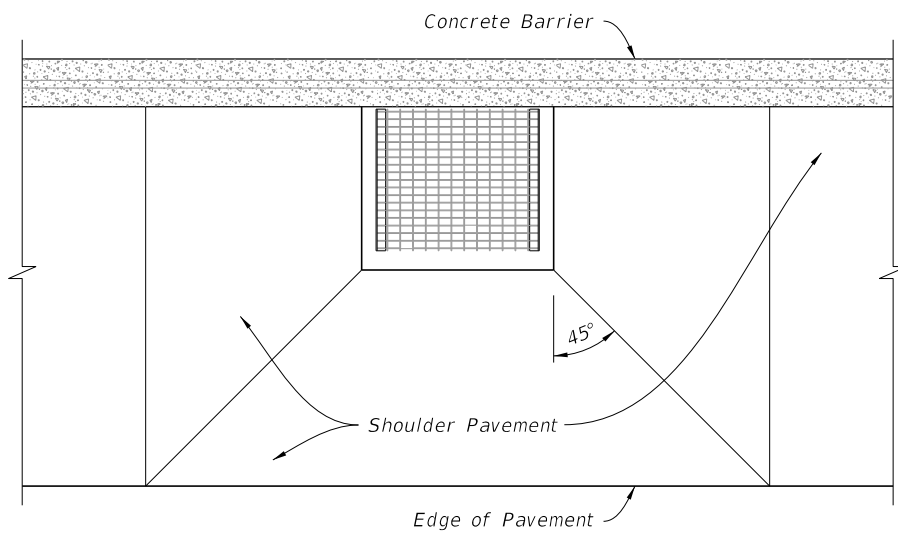

HIGH SIDE TRANSITION

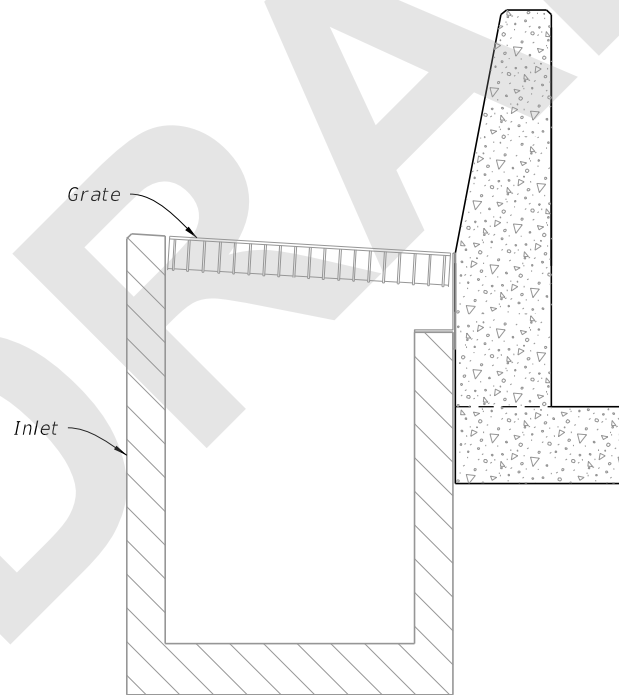

STEM AND FOOTING

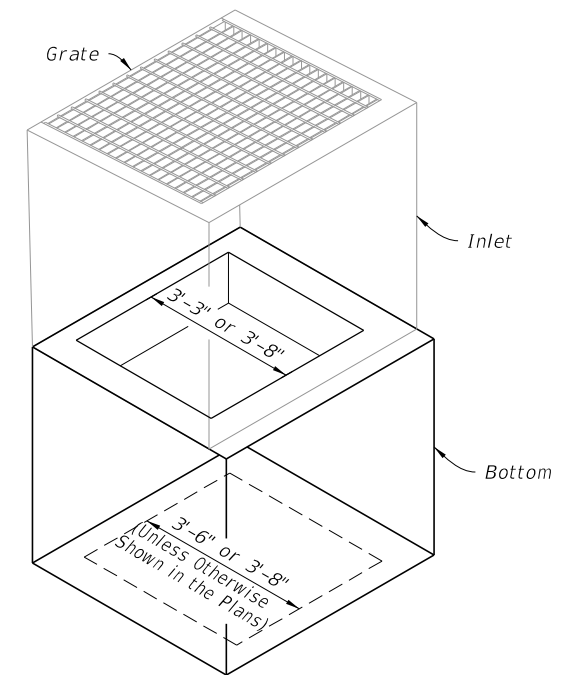

ALTERNATE B STRUCTURE BOTTOM

NOTE: Alt. B Structure Bottom Only. See Index 425-010

===== SUPERELEVATION SHOULDER PAVEMENT WRAP =====

===== BARRIER TYPE EXAMPLES =====

===== INLET WITH STRUCTURE BOTTOM =====

SHOULDER PAVEMENT WRAP, BARRIER TYPE EXAMPLES, AND STRUCTURE BOTTOMS

9/1/2020 9:27:26 AM

LAST REVISION	DESCRIPTION:
11/01/20	



FY 2021-22  
STANDARD PLANS

ADJACENT BARRIER INLET

INDEX  
425-031

SHEET  
4 of 4