
Index 425-052 Ditch Bottom Inlet Types C, D, E, and H

ORIGINATION

Date: 11-1-19

Name: Tim Holley

Phone: 850 414-4117

Email: tim.holley@dot.state.fl.us

COMMENTARY

Reorganized Details and Sheets to declutter Index. Moved information from detail callouts to Notes in order to decrease clutter of the drawing. Moved design information to SPI.

COMMENTS AND RESPONSES

BLACK = Internal Review Comments **RED** = Standard Plans Response

Name: Missy Hollis

Date: 8-10-20

COMMENT: The term used in the Ditch Bottom Inlet indexes referring to either ditch pavement or inlet pavement around the inlet could be confusing, since Specification 524 pertains to ditch pavement. As the concrete surrounding the inlet is to be included in the cost of the inlet, it is recommended to change the term to “concrete apron” in order to differentiate that concrete from the pavement outlined in Specification 524.

RESPONSE: Agreed

Change made to Index: The index was revised to include concrete apron in the place of concrete ditch pavement.

Date: 8-24-2020

Name: Jeffrey Cicerello

Date: 8-21-20

COMMENT: Sheet 10, Detail B: Detail incomplete; Sloped portion of ditch pavement not given or necessary widths. Is this to match the side slope?

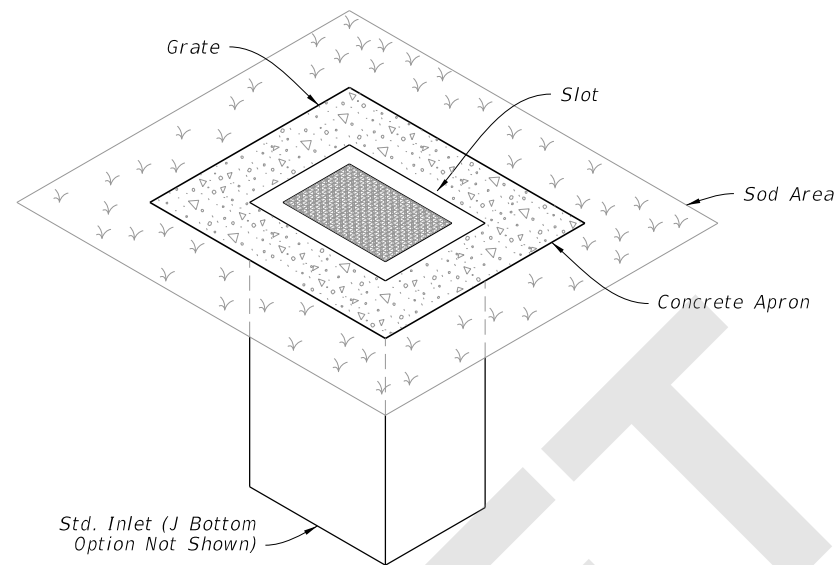
RESPONSE: It looks like the 1'-6" dimension has been the only one shown since the detail(s) were added to the indexes. The detail implies that the contractor would create a slope to tie into the inlet and the slope at the 1'-6" distance. This will be further investigated for the next cycle of Standard Plans updates.

No change to Index at this time

Date: 8-28-20

GENERAL NOTES:

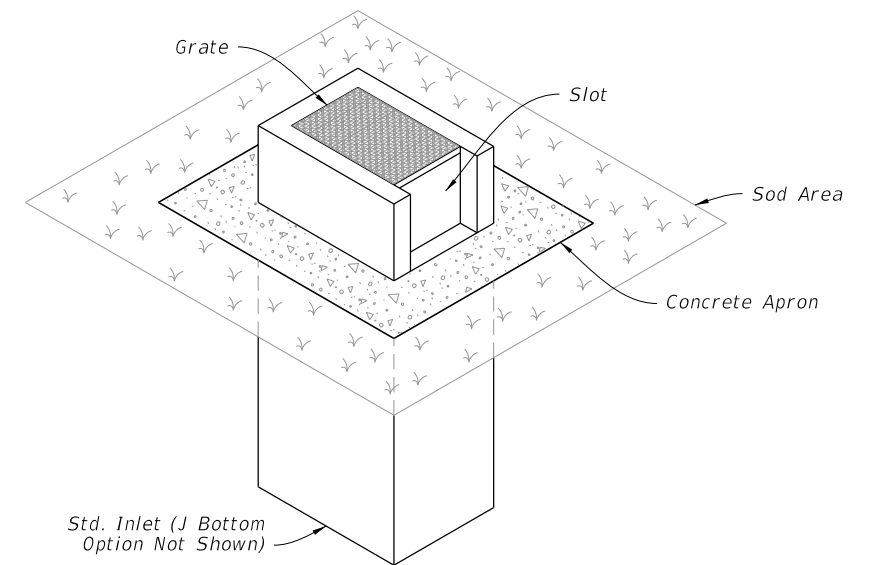
1. Work this Index with Index 425-001 and Index 425-010.
2. Chamfer all exposed edges and corners $\frac{3}{4}$ " chamfer or tooled to $\frac{1}{4}$ " radius.
3. All reinforcing is Grade 60 bars with 2" minimum cover unless otherwise noted. Cut or bend bars for $1\frac{1}{2}$ " clearance around pipe opening. Provide one additional #4 bar above and at each side of pipe opening.
4. Use Concrete Apron on inlets without slots and inlets with non-traversable slots only when called for in the Plans.
5. Quantities are for informational and estimating purposes only.



=====**DITCH BOTTOM INLET TYPE C**=====

TRAVERSABLE

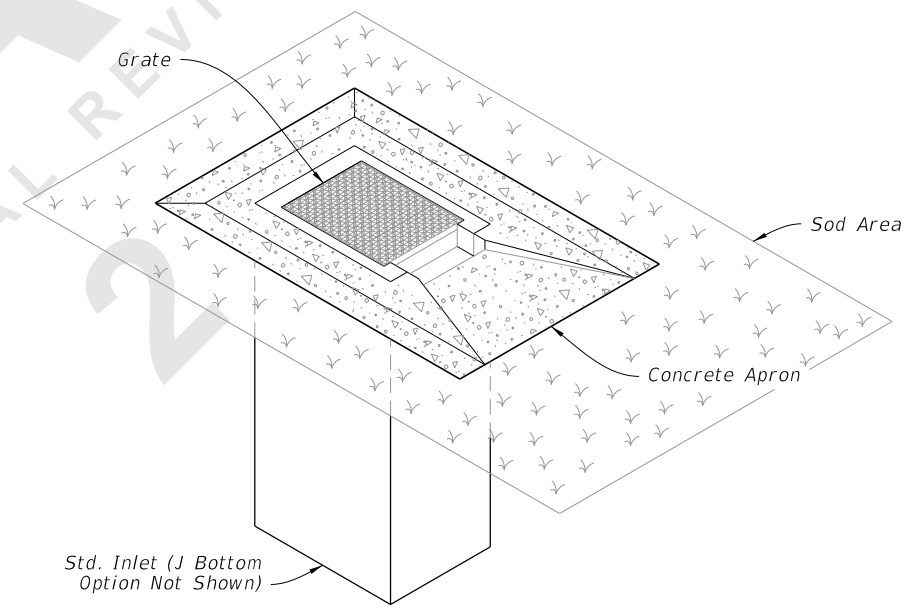
(Without Slot - Type D, E, and H Similar, Pipe Connection Not Shown)



=====**DITCH BOTTOM INLET TYPE C**=====

NON-TRAVERSABLE

(Slot > 7" Shown - Type D, E, and H Similar, Pipe Connection Not Shown)



=====**DITCH BOTTOM INLET TYPE C**=====

TRAVERSABLE

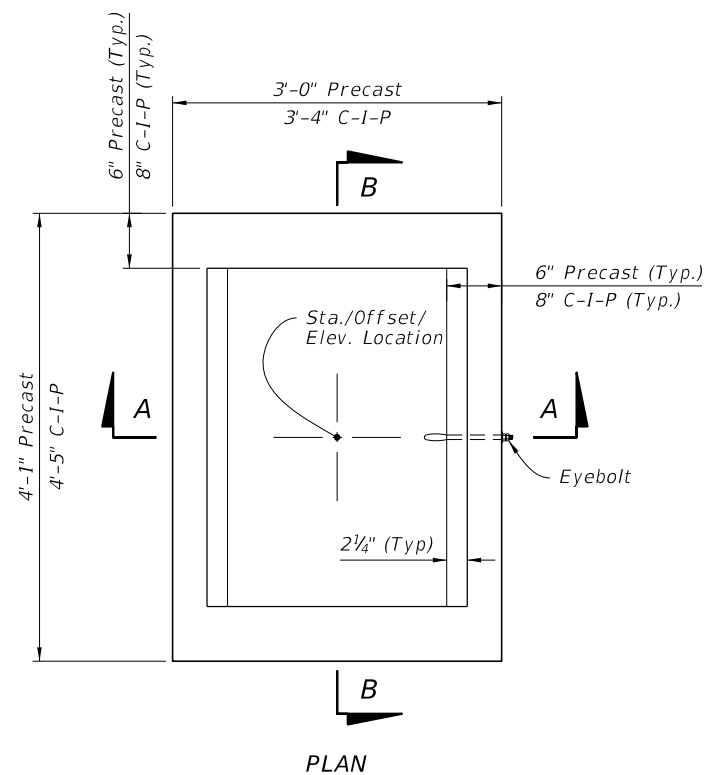
(Single Slot < 7" Shown, Double Slot, Type D, and E Similar, Pipe Connection Not Shown)

TABLE OF CONTENTS:

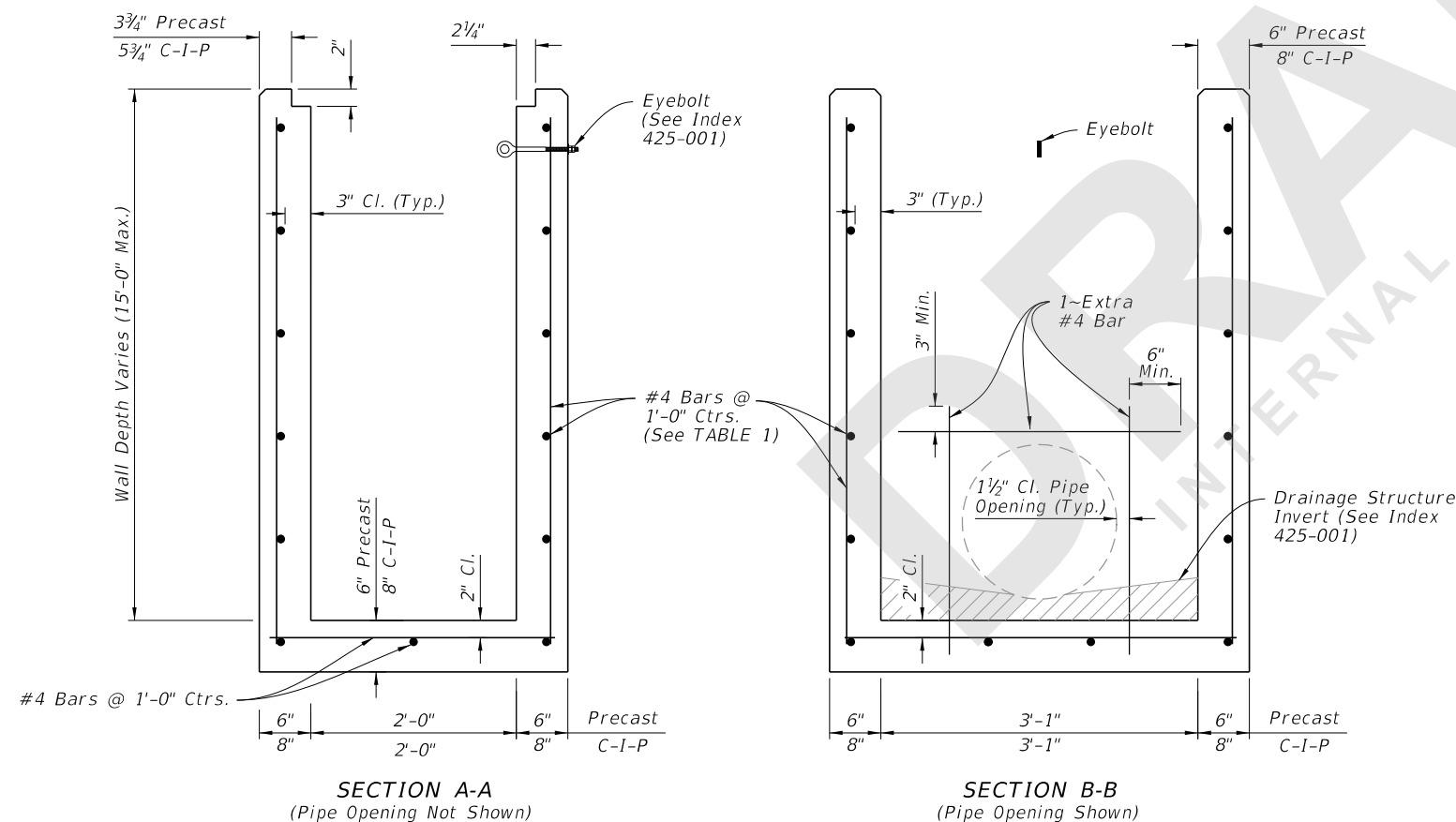
Sheet	Description
1	General Notes and Contents
2	Type C - Dimensional, Reinforcement, and Grate Details
3	Type D - Dimensional, Reinforcement, and Grate Details
4	Type E - Dimensional, Reinforcement, and Grate Details
5	Type H (2 & 3 Grate) - Dimensional, Reinforcement, and Steel Grate Details
6	Type H (4 Grate) - Dimensional, Reinforcement, and Steel Grate Details
7	Cast Iron Grate Details
8	Non-Traversable Inlet Details
9	Traversable Inlet Without Slot Details
10	Traversable Inlet With Slot Details
11	Case 1 - Add Traversable Slots to Existing Inlets
12	Case 2 - Add Traversable Slots (Partial) to Existing Inlets
13	Case 3 - Add Traversable Slots (Partial) to Existing Inlets and Ditch Block
14	Alternate A Structure Bottom - Top Slab Details

8/28/2020 7:44:33 AM

LAST REVISION	11/01/20	REVISION	DESCRIPTION:
---------------	----------	----------	--------------

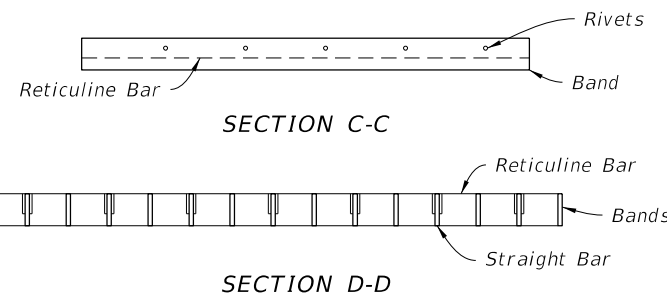
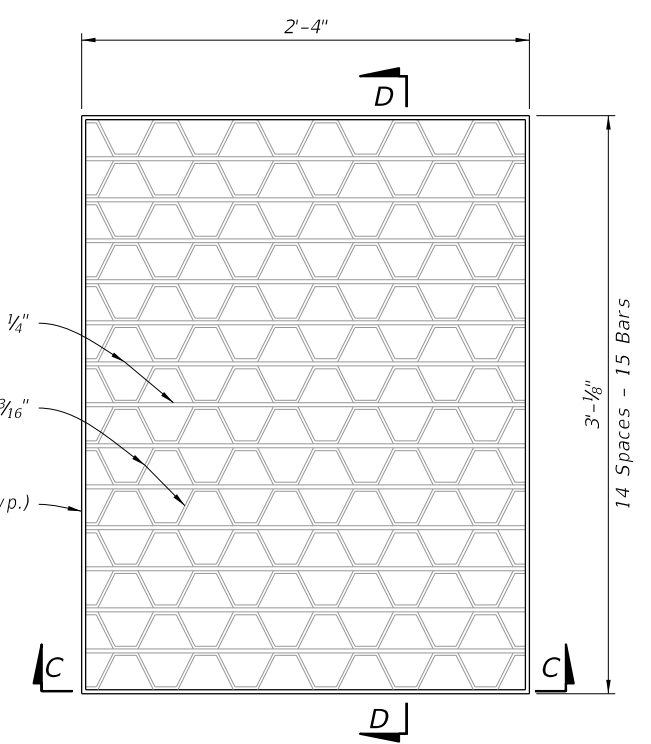


PLAN



SECTION A-A
(Pipe Opening Not Shown)

SECTION B-B
(Pipe Opening Shown)



STEEL GRATE DETAIL

(Approx. 104 Lbs. - See Sheet 7 For Cast Iron Grates)

TABLE 1
HORIZONTAL WALL REINFORCING SCHEDULE

WALL DEPTH	SCHEDULE	AREA (in. ² /ft.)	MAX. SPACING	
			BAR	WWF
0' - 15'	A12	0.20	12"	8"

NOTES:

1. Grate, Concrete Apron, and Sod not shown on structure detail.
2. See Sheet 8, 9, and 10 for Concrete Apron and Sodded Area details.

DIMENSIONAL AND REINFORCEMENT DETAILS

TYPE C - DIMENSIONAL, REINFORCEMENT, AND STEEL GRATE DETAILS

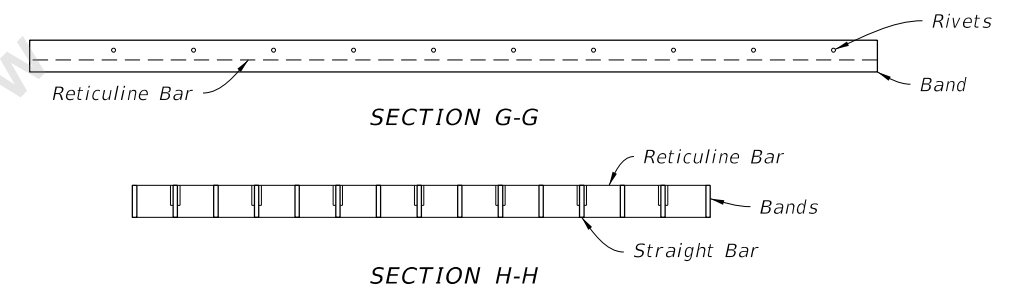
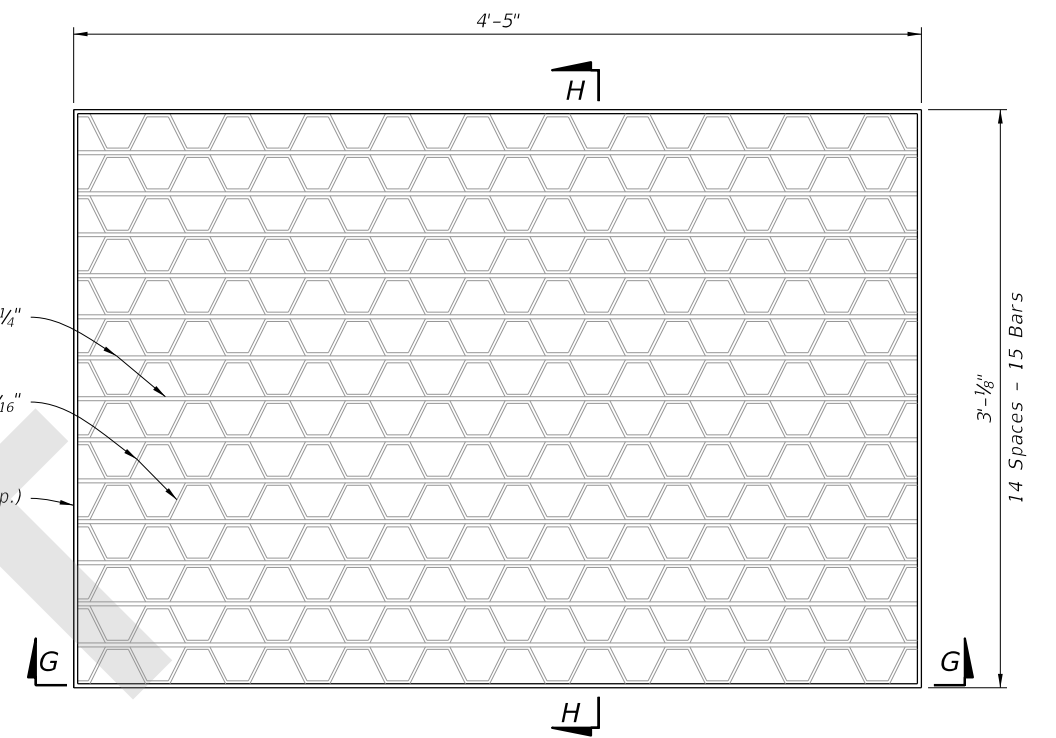
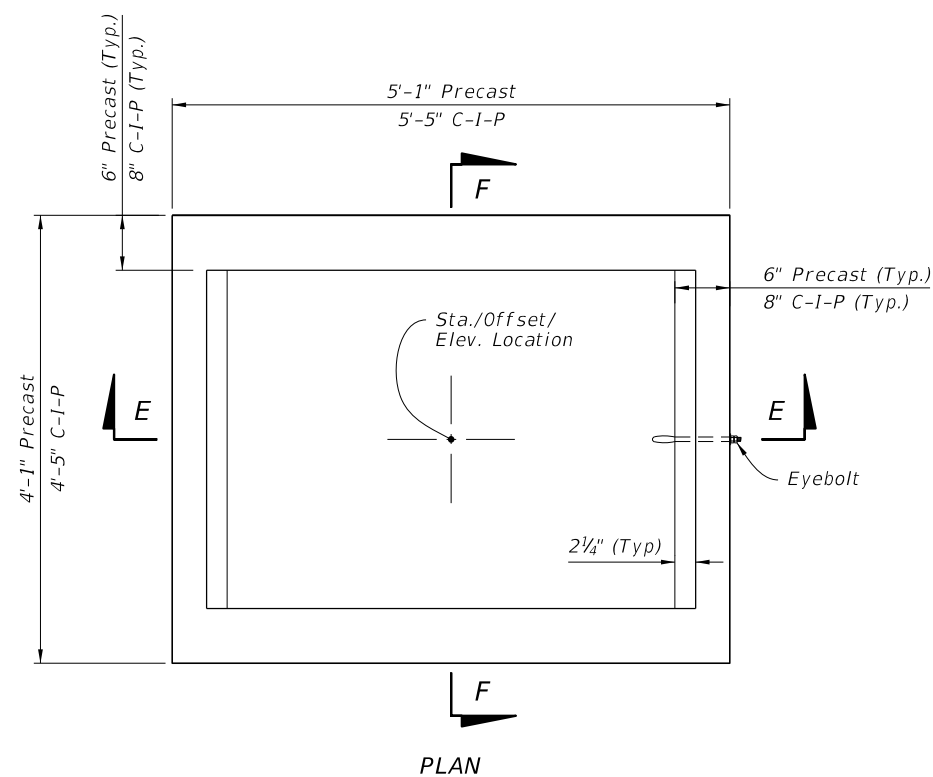
8/28/2020 7:44:35 AM

LAST REVISION 11/01/20	DESCRIPTION:
---------------------------	--------------

FDOT
FY 2021-22
STANDARD PLANS

DITCH BOTTOM INLET TYPE C, D, E, AND H

INDEX 425-052	SHEET 2 of 14
------------------	------------------



STEEL GRATE DETAIL
(Approx. 190 lbs. - See Sheet 7 For Cast Iron Grates)

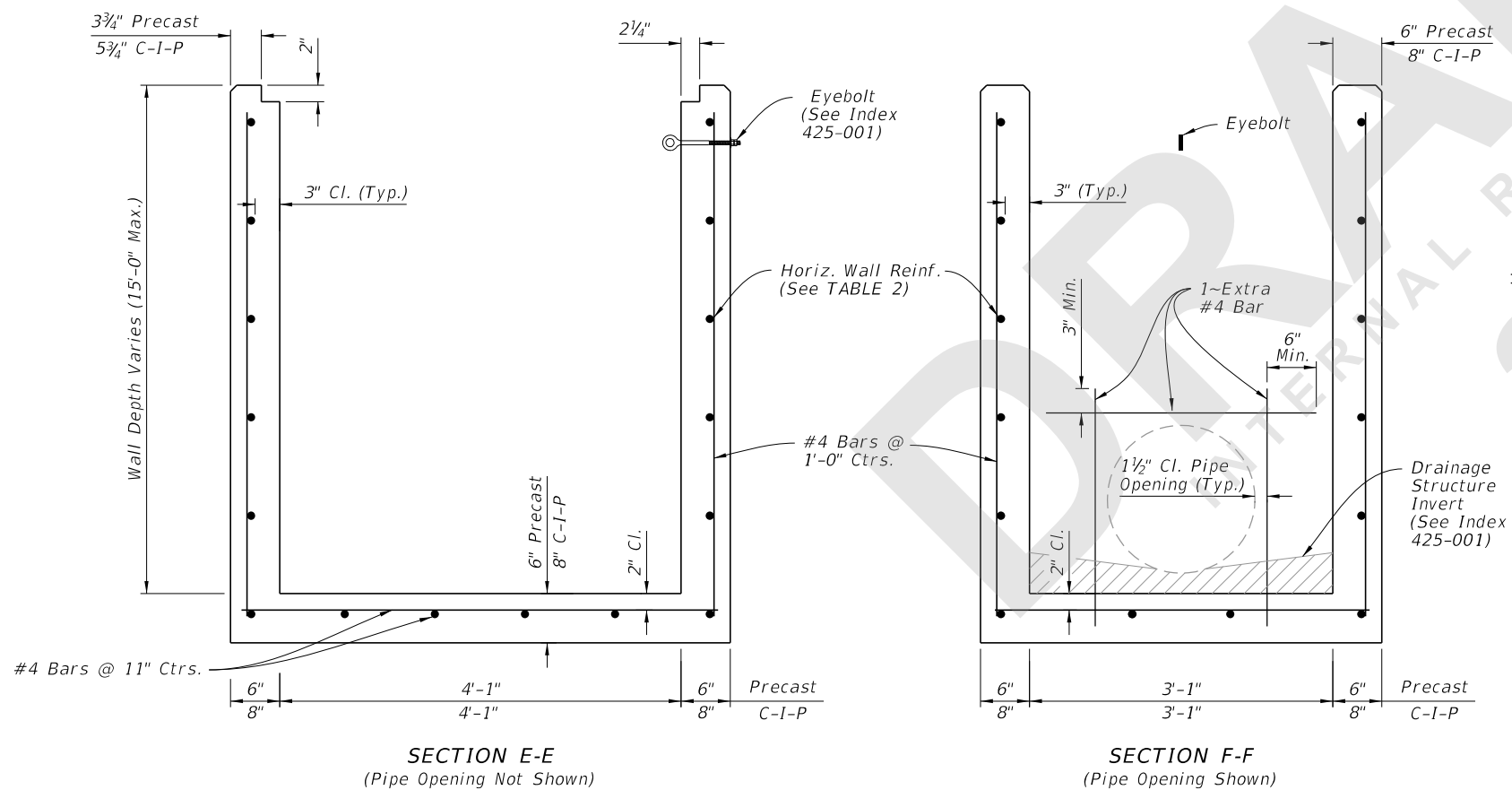


TABLE 2
HORIZONTAL WALL REINFORCING SCHEDULE

WALL DEPTH	SCHEDULE	AREA (in. ² /ft.)	MAX. SPACING	
			BARS	WWR
0' - 6'	A12	0.20	12"	8"
6' - 10'	A6	0.20	6"	5"
10' - 13'	A4	0.20	4"	3"
10' - 15'	B5.5	0.24	5 1/2"	5"

NOTES:

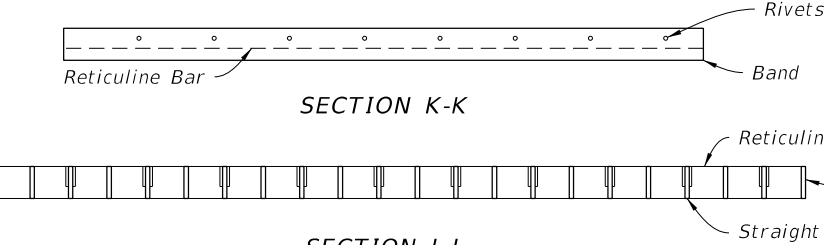
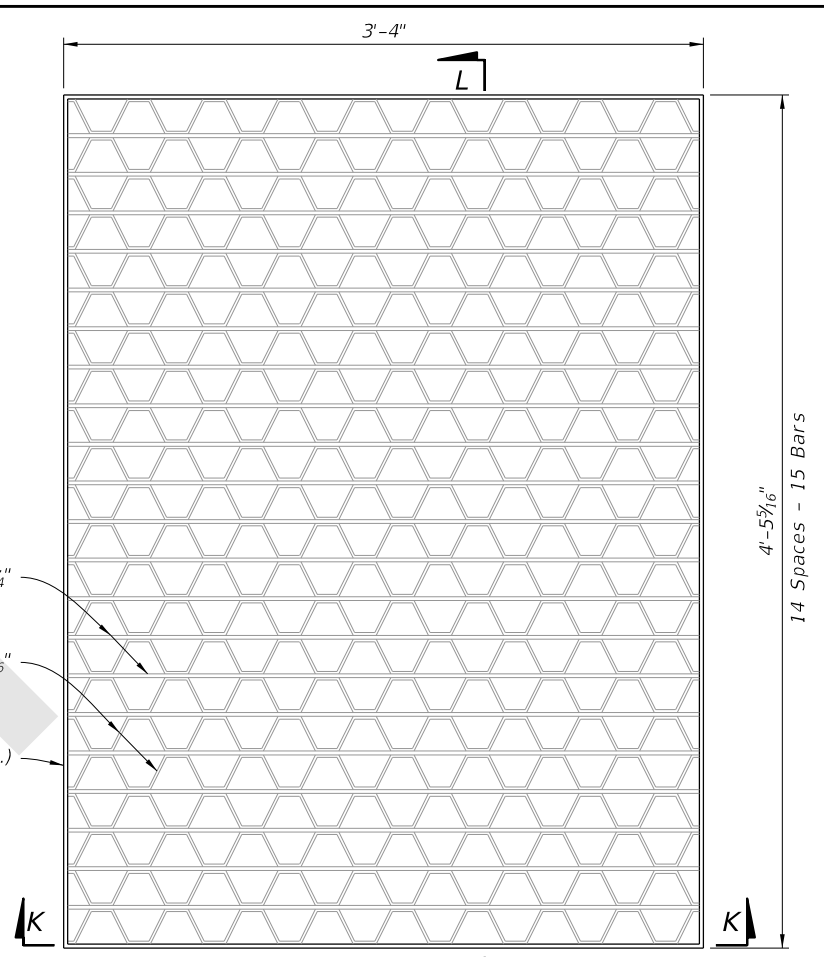
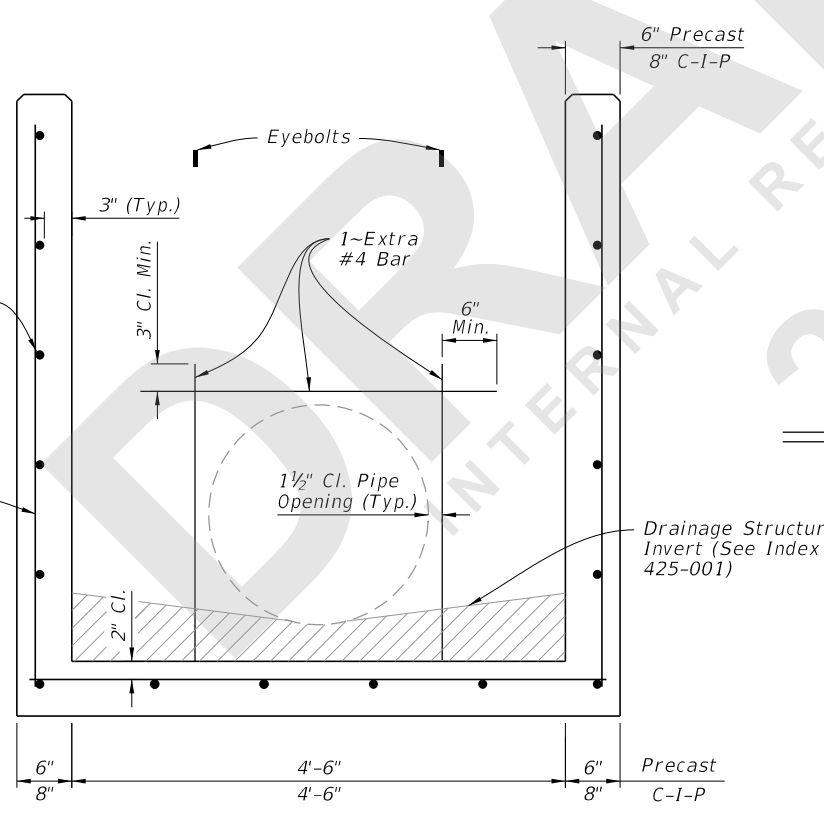
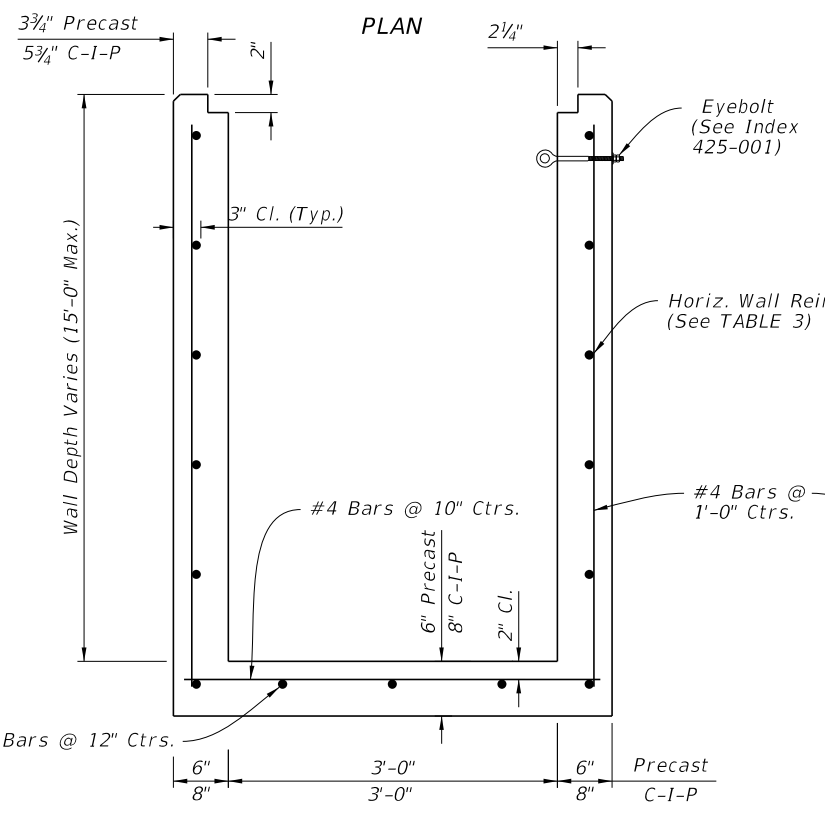
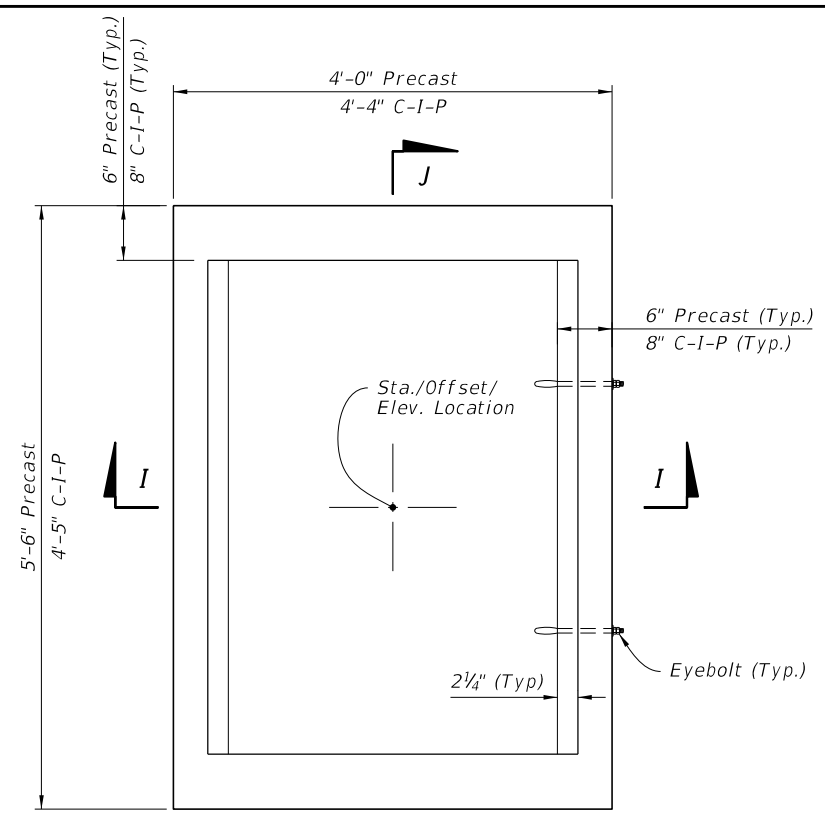
1. Grate, Concrete Apron, and Sod not shown on structure details.
2. See Sheet 8, 9, and 10 for Concrete Apron and Sodded Area details.
3. Cast Iron Grate is not permitted on inlet Type D.

DIMENSIONAL AND REINFORCEMENT DETAILS

TYPE D - DIMENSIONAL, REINFORCEMENT, AND STEEL GRATE DETAILS

8/28/2020 7:44:38 AM

LAST REVISION 11/01/20	DESCRIPTION:		FY 2021-22 STANDARD PLANS	DITCH BOTTOM INLET TYPE C, D, E, AND H	INDEX	SHEET
					425-052	3 of 14



STEEL GRATE DETAIL
(Approx. 215 lbs. - See Sheet 7 For Cast Iron Grates)

TABLE 3
HORIZONTAL WALL REINFORCING SCHEDULE

WALL DEPTH	SCHEDULE	AREA (in. ² /ft.)	MAX. SPACING	
			BARS	WWR
0' - 5'	A12	0.20	12"	8"
0' - 7.5'	A6	0.20	6"	5"
7.5' - 10'	B5.5	0.24	5 1/2"	5"
10' - 15'	C6.5	0.37	6 1/2"	6"

- NOTES:**
1. Grate, Concrete Apron, and Sod not shown on structure detail.
 2. See Sheet 8, 9, and 10 for Concrete Apron and Sodded Area details.

DIMENSIONAL AND REINFORCEMENT DETAILS

TYPE E - DIMENSIONAL, REINFORCEMENT, AND STEEL GRATE DETAILS

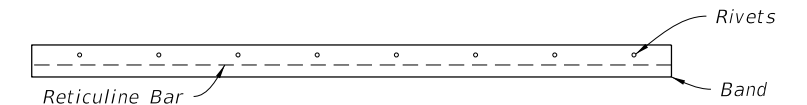
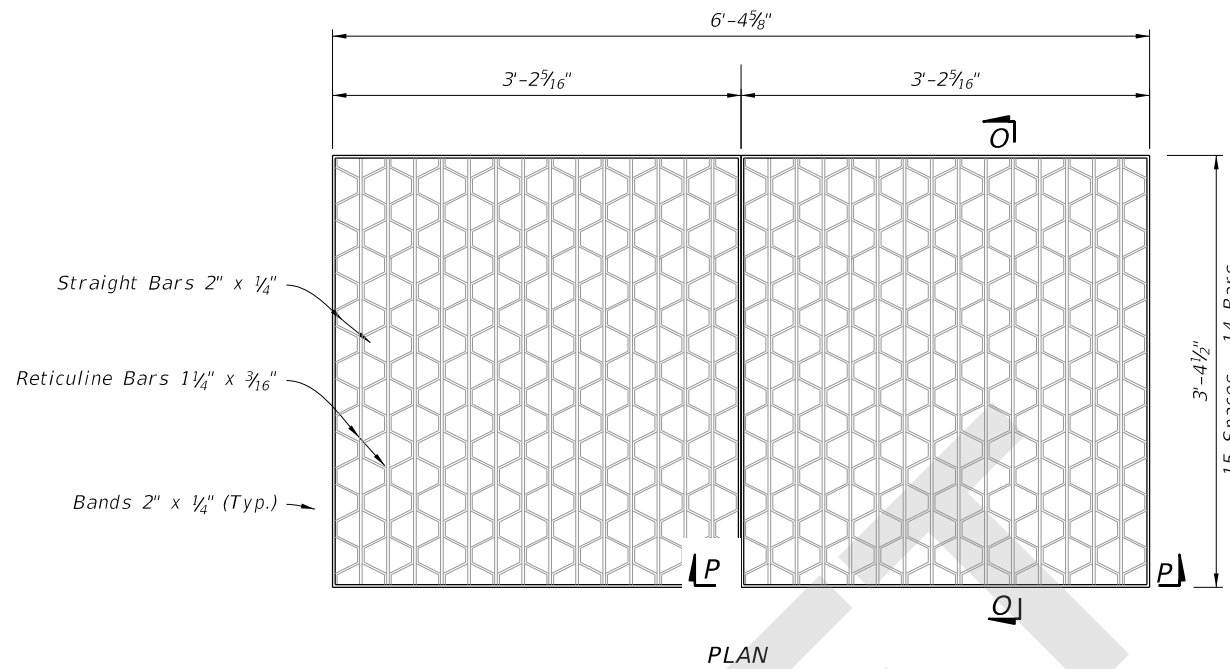
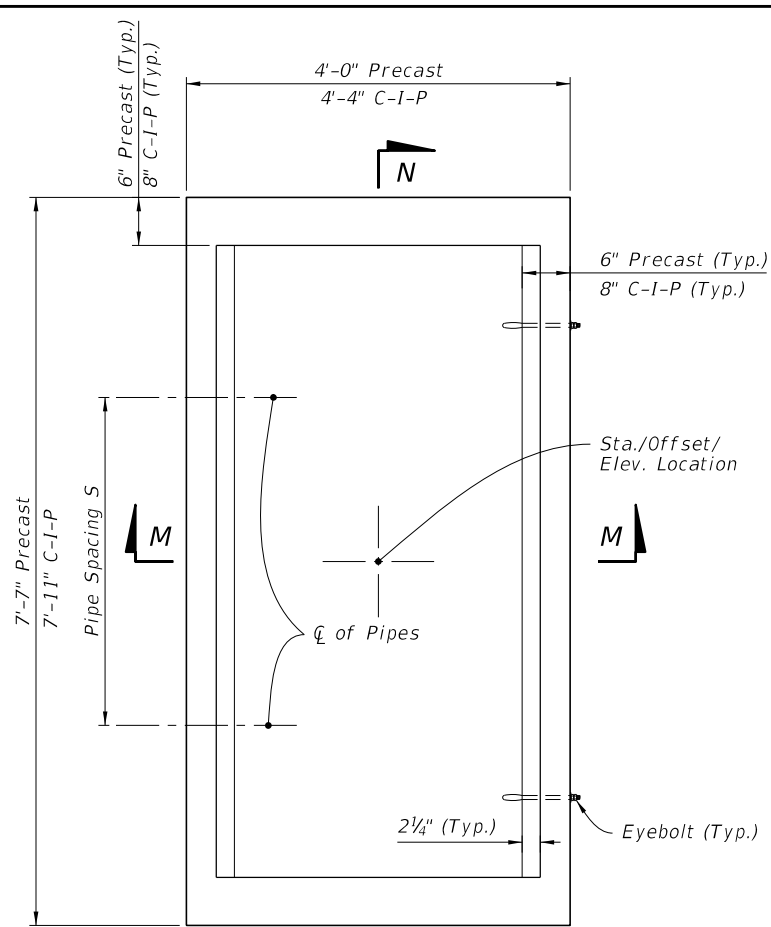
8/28/2020 7:44:40 AM

LAST REVISION	DESCRIPTION:
11/01/20	

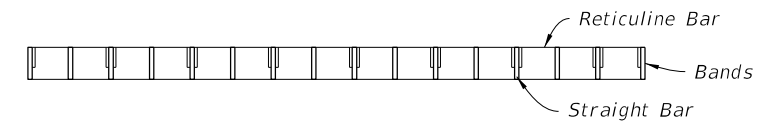
FDOT FY 2021-22 STANDARD PLANS

DITCH BOTTOM INLET TYPE C, D, E, AND H

INDEX	SHEET
425-052	4 of 14



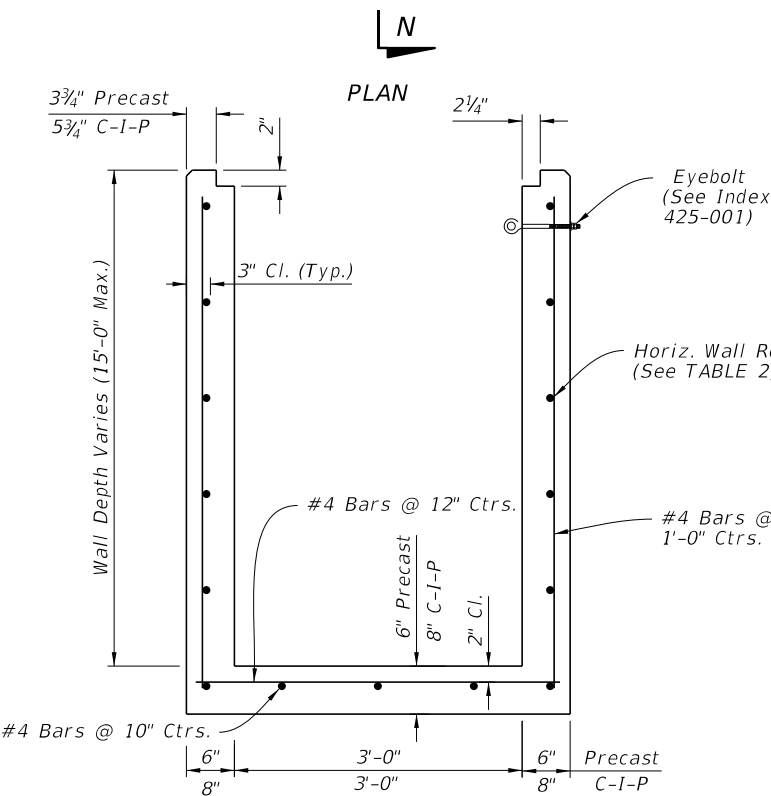
SECTION O-O



SECTION P-P

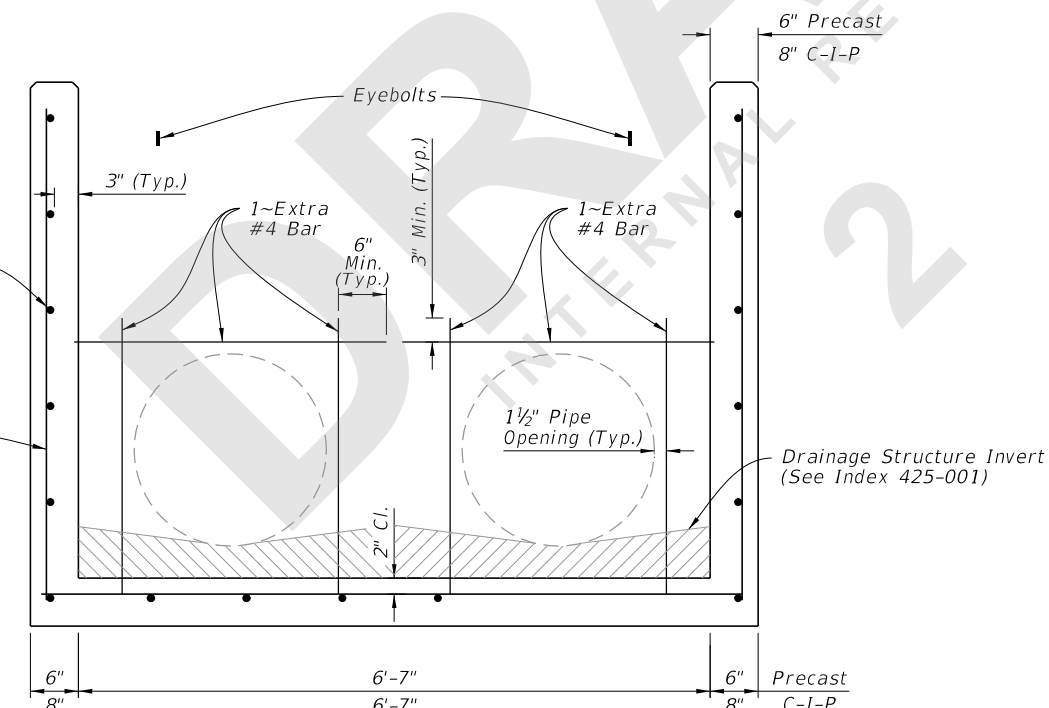
STEEL GRATE DETAIL

(2-Grates Shown, Approx. 310 lbs. - See Sheet 7 For Cast Iron, 3-Grates)



SECTION M-M

(Pipe Opening Not Shown)



SECTION N-N

(Pipe Opening Shown)

WALL DEPTH	SCHEDULE	AREA (in. ² /ft.)	MAX. SPACING	
			BARS	WWR
0' - 5'	B5.5	0.24	5 1/2"	5"
5'-7'	C6.5	0.37	6 1/2"	6"
7' - 15'	D4.5	0.53	4 1/2"	4"

NOTES:

1. Grate, Concrete Apron, and Sod not shown on structure details.
2. See Sheet 8, 9, and 10 for Concrete Apron and Sodded Area details.
3. Pipe Spacing S = 3'-5"

DIMENSIONAL AND REINFORCEMENT DETAILS

TYPE H (2 & 3 GRATE) - DIMENSIONAL, REINFORCEMENT, AND STEEL GRATE DETAILS

8/28/2020 7:44:44 AM

LAST REVISION	DESCRIPTION:
11/01/20	

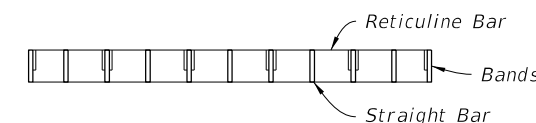
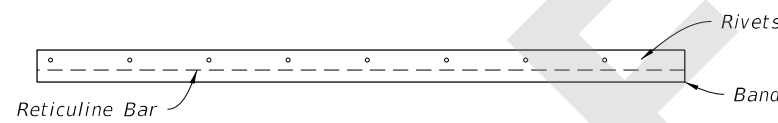
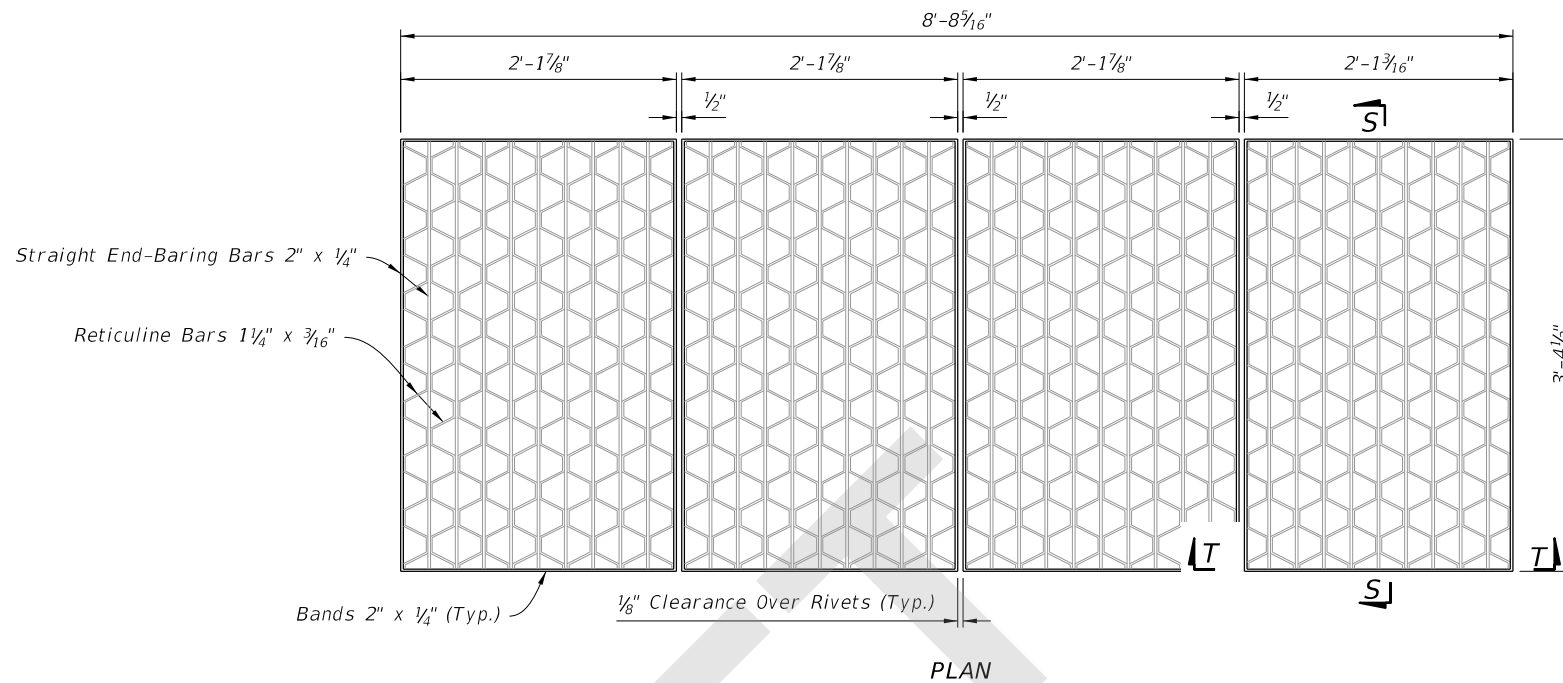
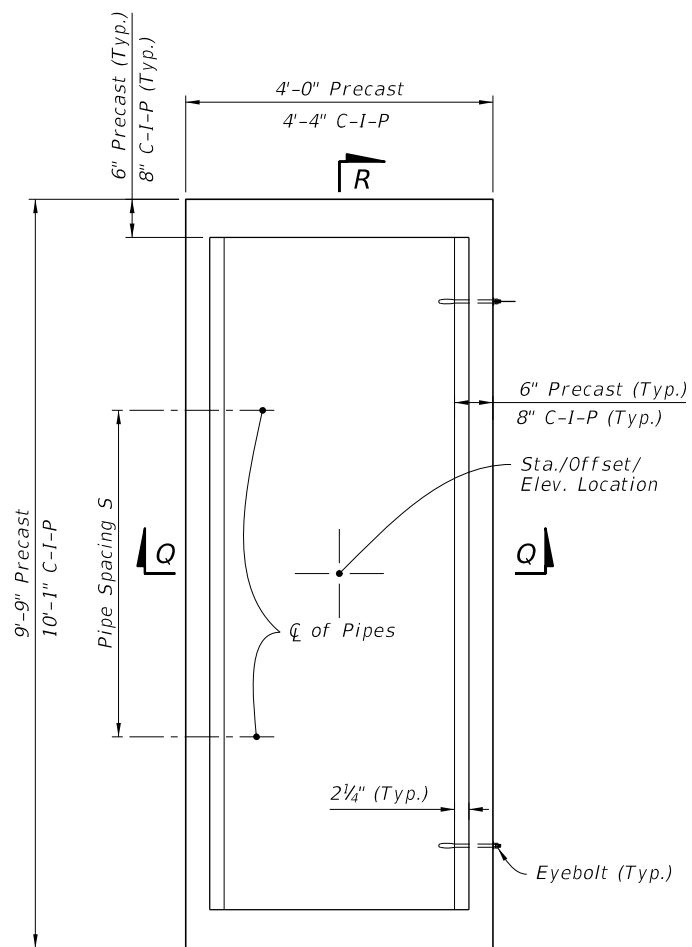


FY 2021-22
STANDARD PLANS

DITCH BOTTOM INLET TYPE C, D, E, AND H

INDEX
425-052

SHEET
5 of 14



STEEL GRATE DETAIL

(Approx. 388 lbs. - See Sheet 7 For Cast Iron Grates)

PLAN

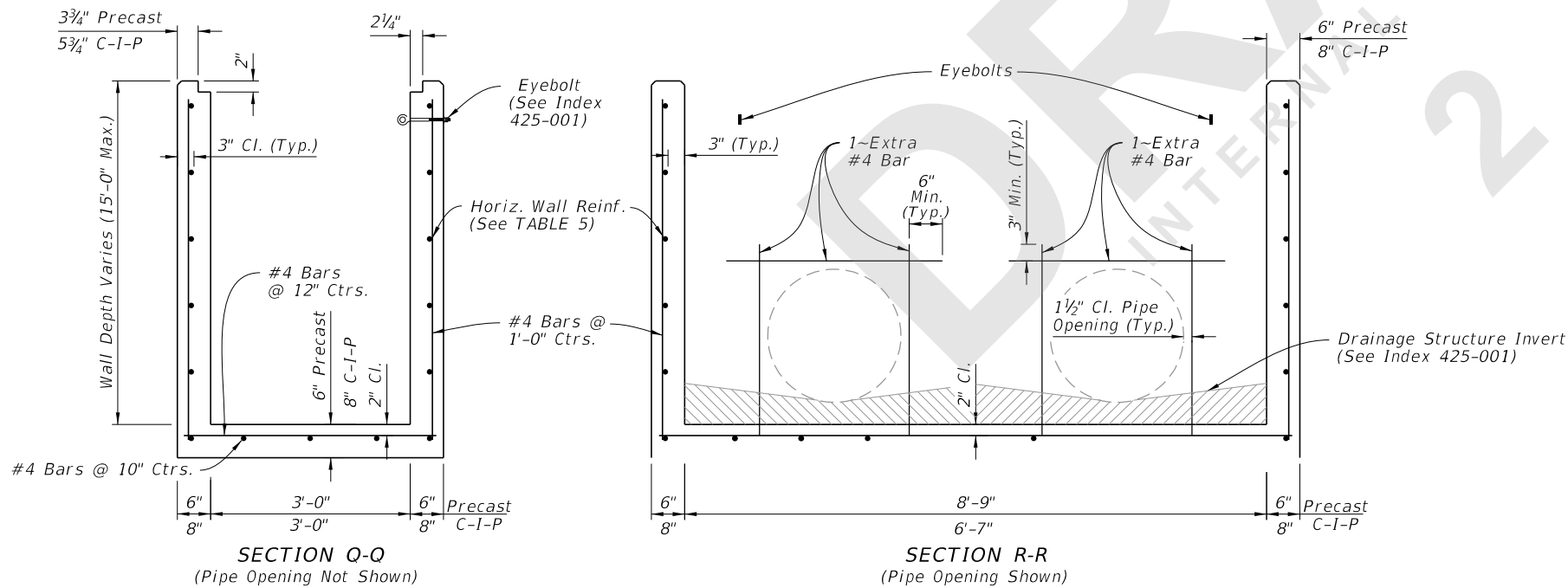


TABLE 5
HORIZONTAL WALL REINFORCING SCHEDULE

WALL DEPTH	SCHEDULE	AREA (in. ² /ft.)	MAX. SPACING	
			BARS	WWR
0' - 5'	C3.5	0.37	3 1/2"	3"
5'-10'	D4.5	0.53	4 1/2"	4"

NOTES:

1. Grate, Concrete Apron, and Sod not shown on structure details.
2. See Sheet 8, 9, and 10 for Concrete Apron and Sodded Area details.
3. Pipe Spacing S = 4'-3"

DIMENSIONAL AND REINFORCEMENT DETAILS

TYPE H (4 GRATE) - DIMENSIONAL, REINFORCEMENT, AND STEEL GRATE DETAILS

8/28/2020 7:44:46 AM

LAST REVISION 11/01/20	DESCRIPTION:
---------------------------	--------------



FY 2021-22
STANDARD PLANS

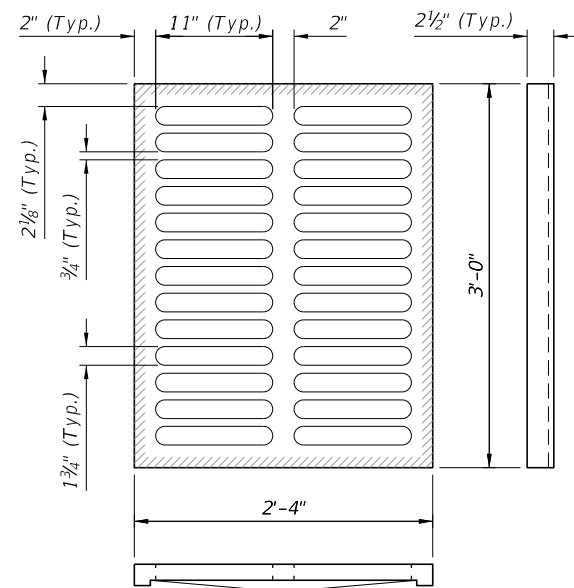
DITCH BOTTOM INLET TYPE C, D, E, AND H

INDEX
425-052

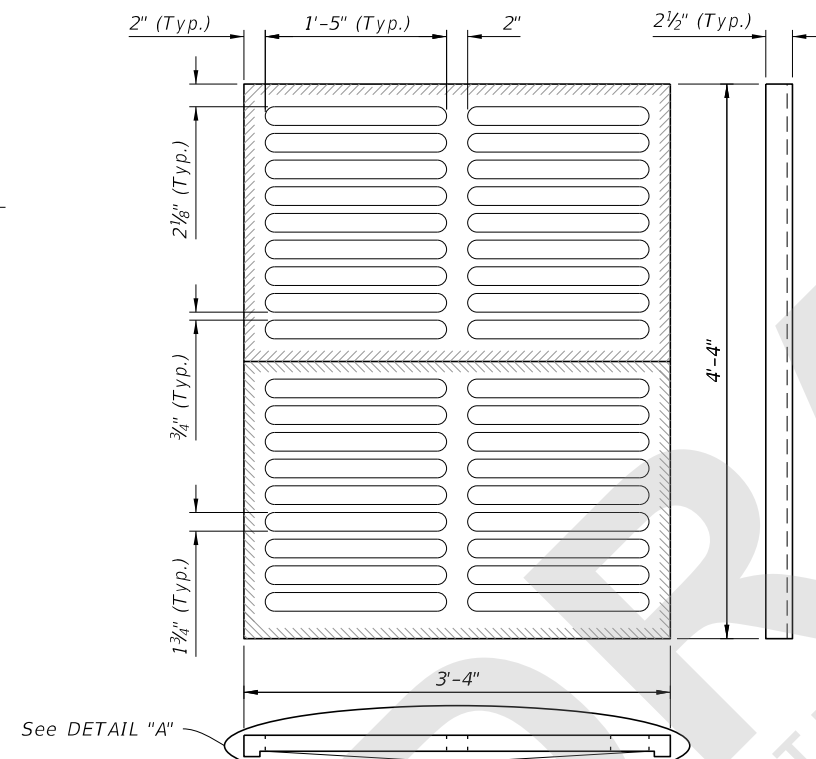
SHEET
6 of 14

NOTES:

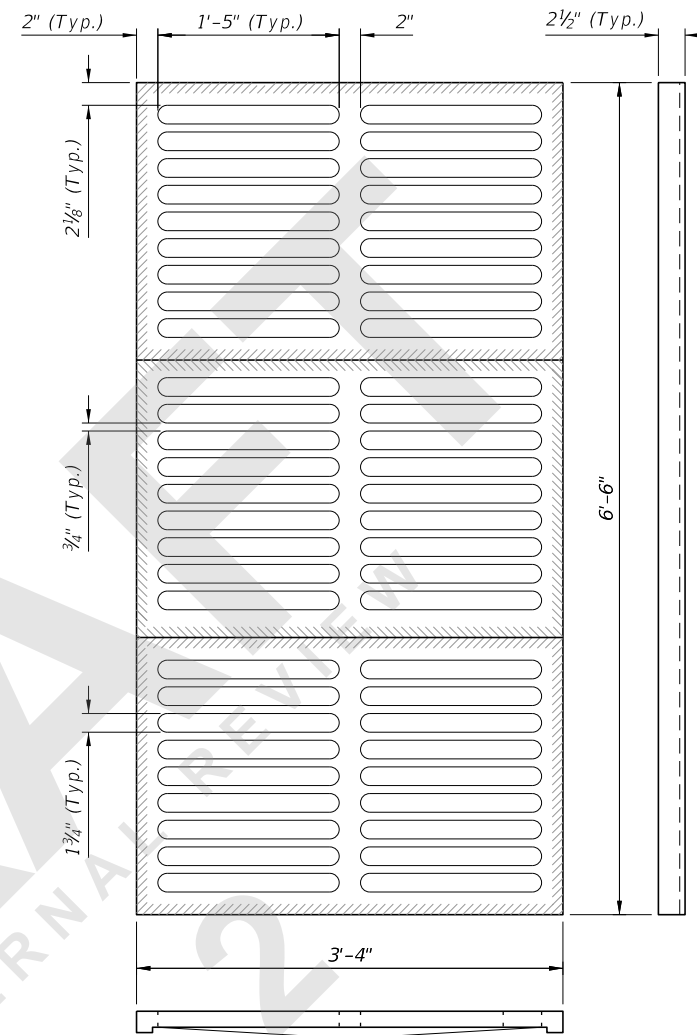
1. Steel Grates are required on inlets with traversable slots and on Inlets where bicycle traffic is anticipated.
2. Cast Iron Grates are not permitted on Inlet Type D.



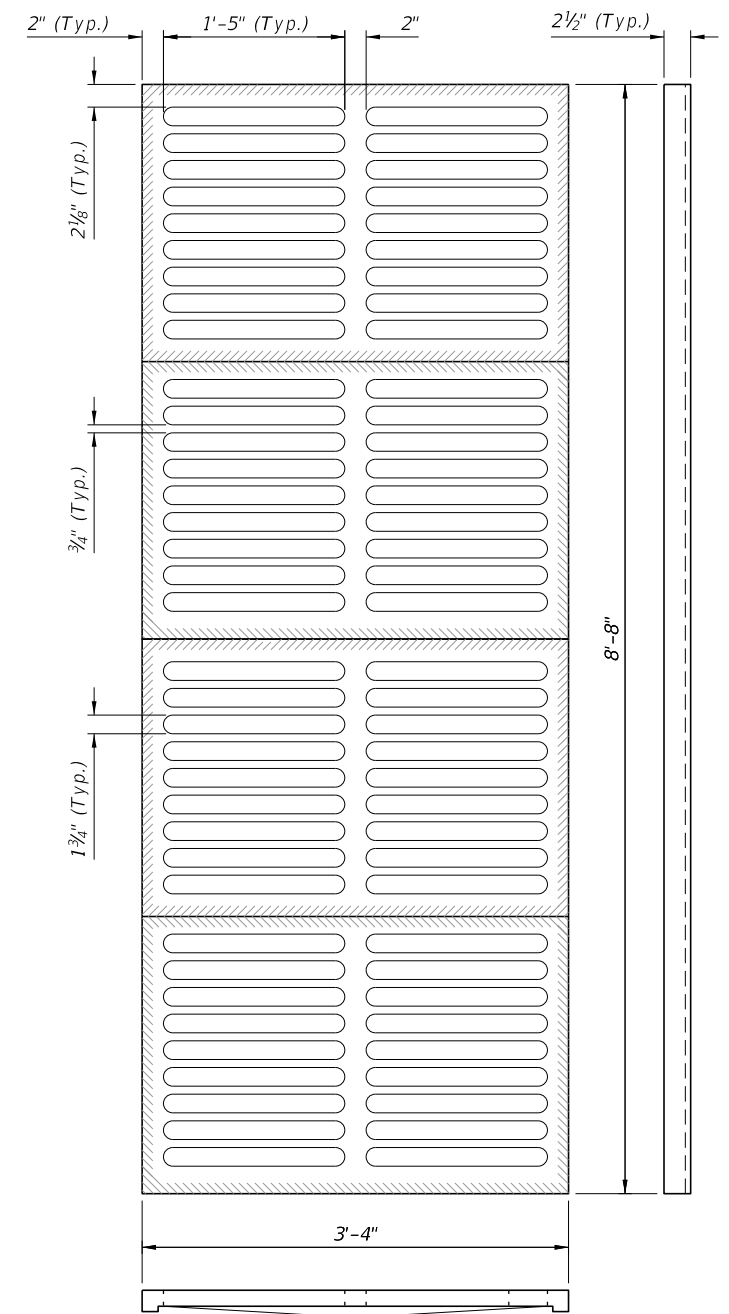
TYPE C
Approx. 235 lbs.



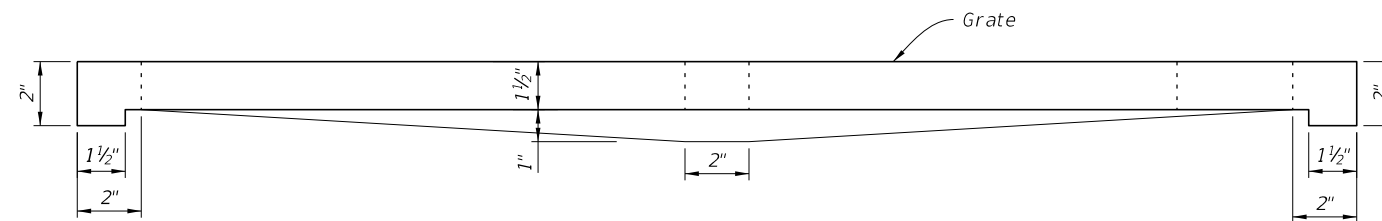
TYPE E
Approx. 465 lbs.



TYPE H
(3-Grate Inlet)
Approx. 725 lbs.



TYPE H
(4-Grate Inlet)
Approx. 967 lbs.



DETAIL "A"
(Typical Section)

CAST IRON GRATE DETAILS

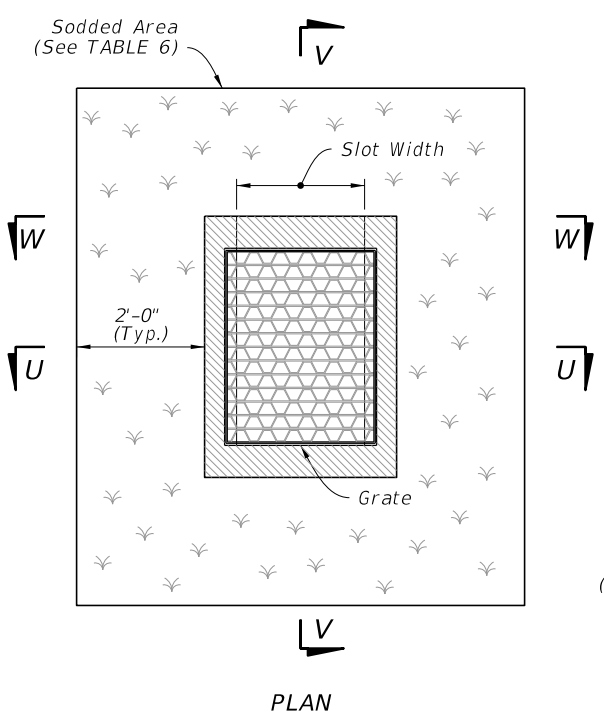
8/28/2020 7:44:50 AM

LAST REVISION 11/01/120	DESCRIPTION:
----------------------------	--------------


**FY 2021-22
STANDARD PLANS**

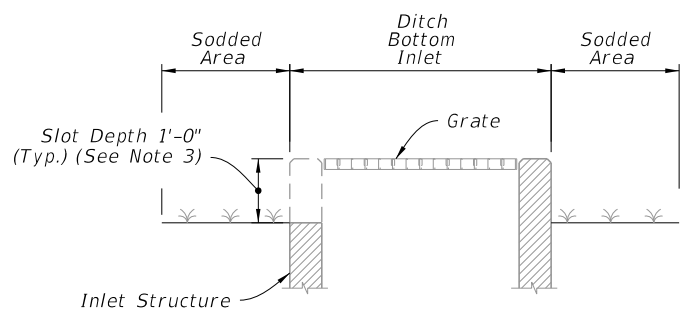
DITCH BOTTOM INLET TYPE C, D, E, AND H

INDEX 425-052	SHEET 7 of 14
------------------	------------------

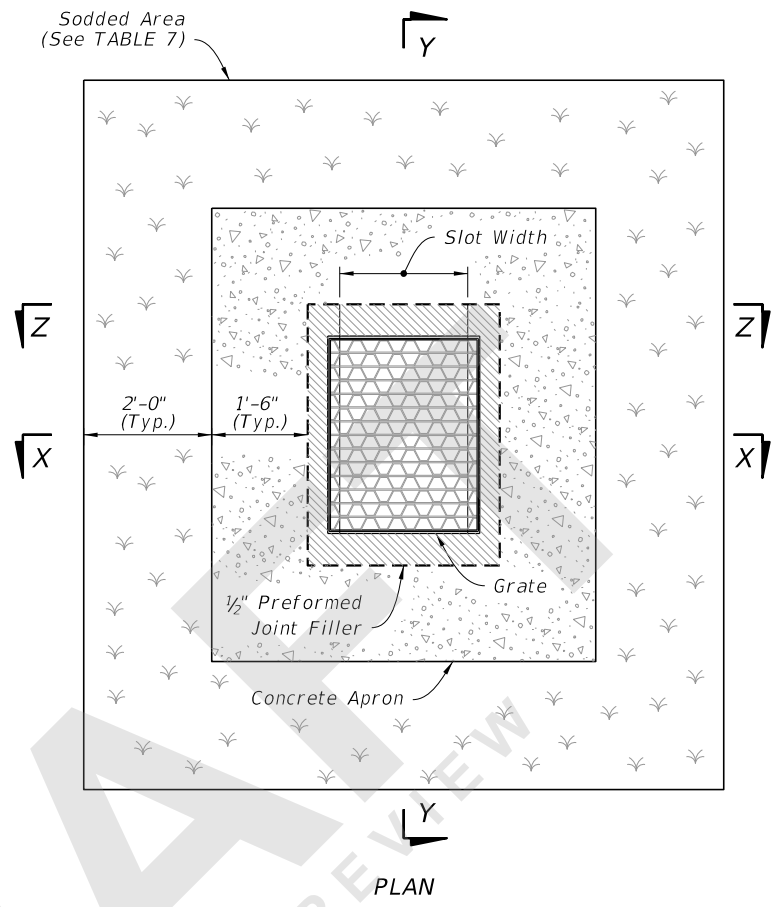


**TABLE 6
SOD ONLY
QUANTITIES**

Inlet Type	Sod SY
C	6
D	6
E	7
H	8

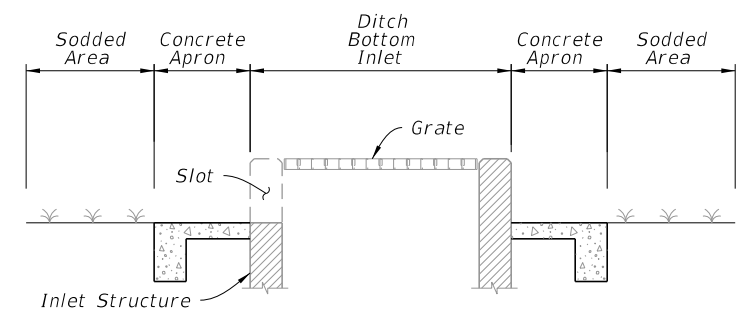


SECTION V-V

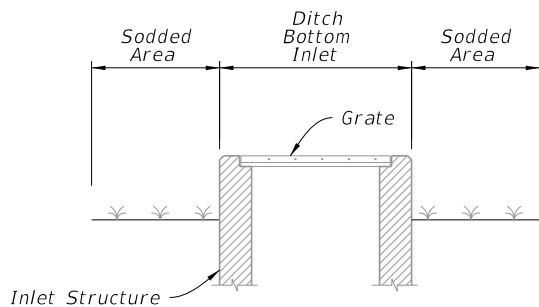


**TABLE 7
SOD AND CONCRETE
APRON QUANTITIES**

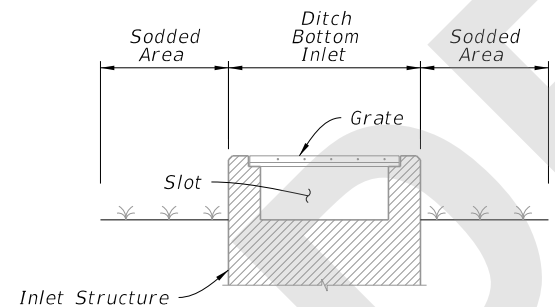
Inlet Type	Sod SY	Conc. CY
C	8	0.30
D	9	0.36
E	9	0.37
H	11	0.45



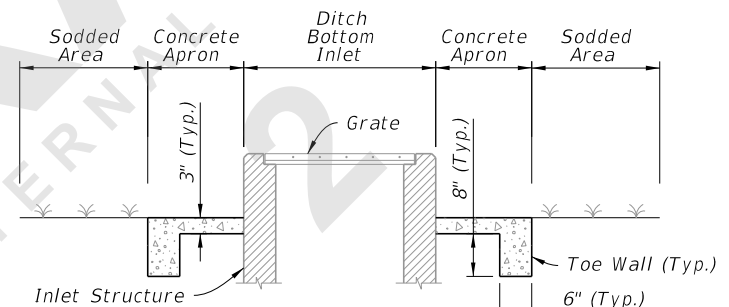
SECTION Y-Y



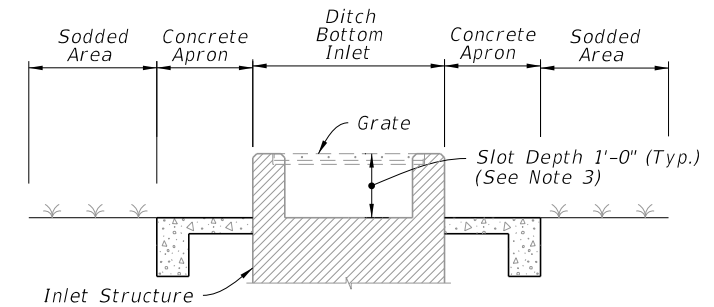
SECTION U-U



SECTION W-W



SECTION X-X



SECTION Z-Z

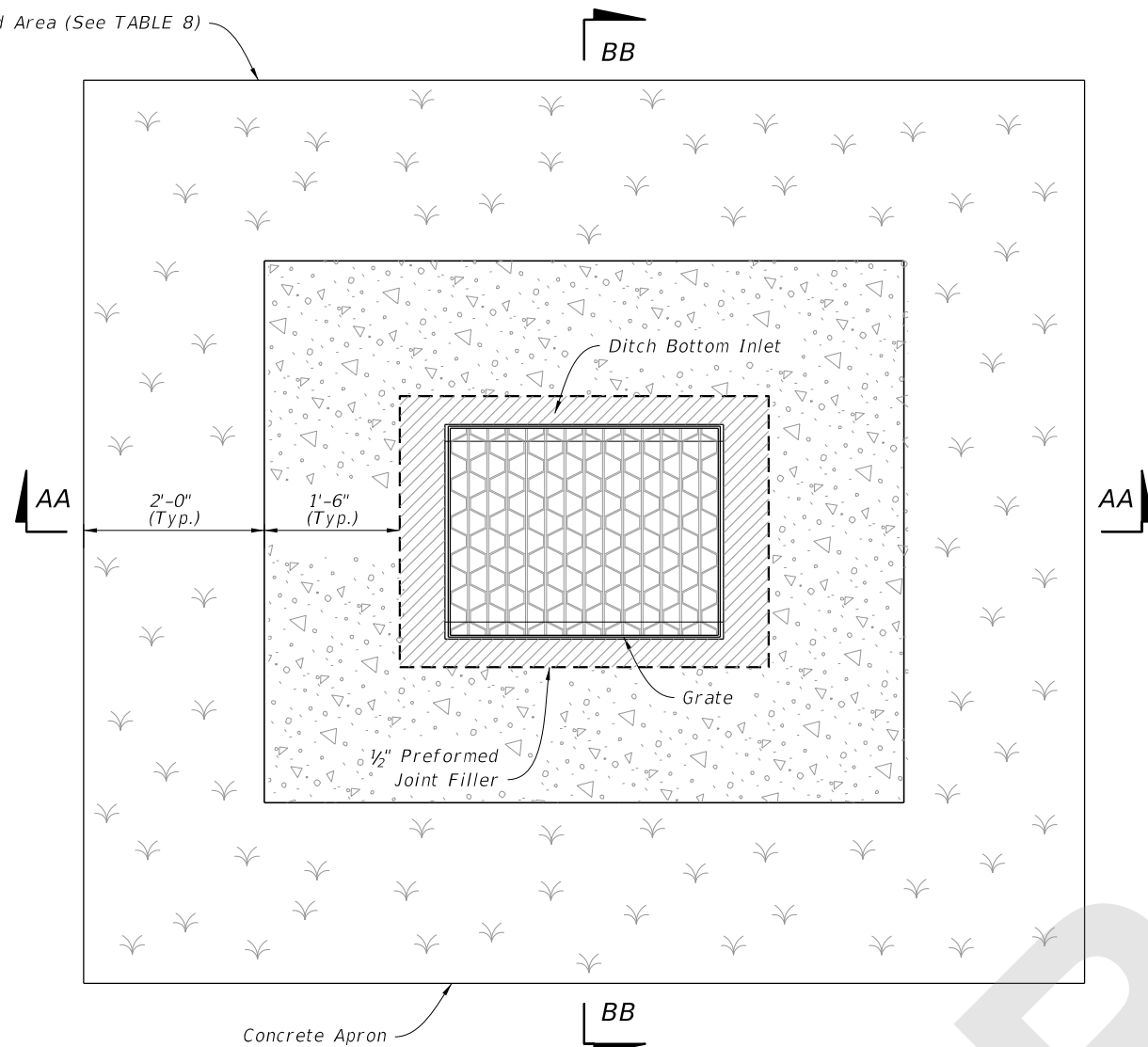
SODDING ONLY
(Slot Shown, Non-Slot Similar)

SODDING AND PAVEMENT
(Slot Shown, Non-Slot Similar)

- NOTES:**
1. Concrete Apron installed only where called for in the Plans.
 2. Sod always required.
 3. Slots are not permitted on sides with grate seats.

8/28/2020 7:44:54 AM

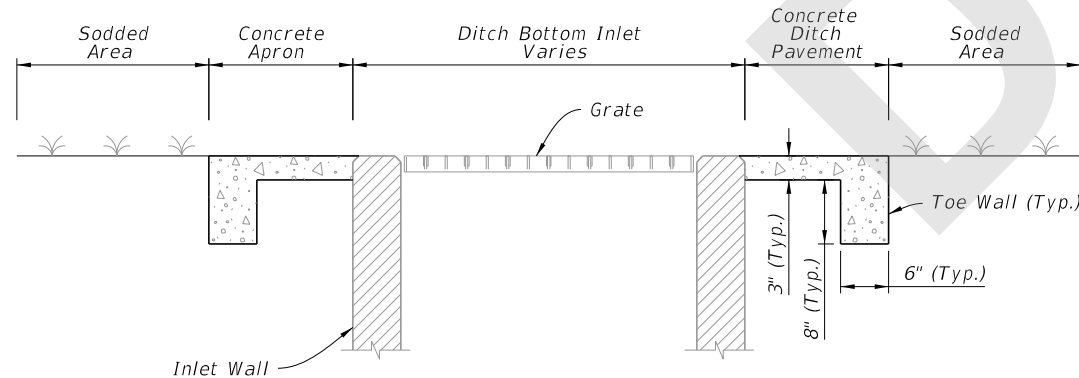
Sodded Area (See TABLE 8)



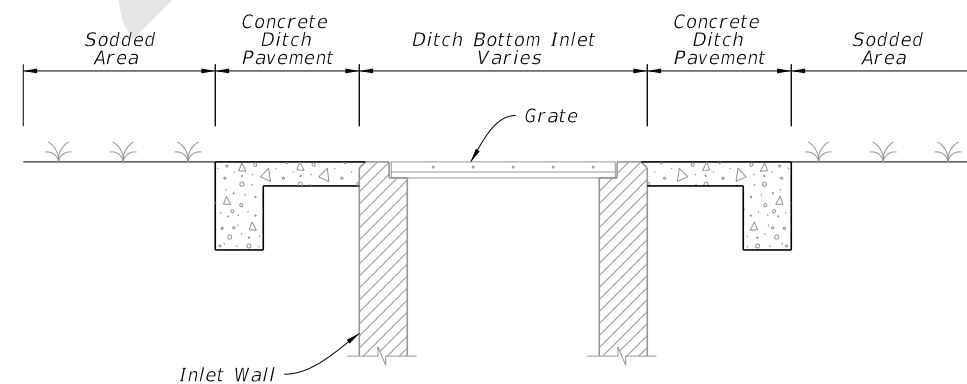
SOD AND PAVEMENT		
Inlet Type	Sod SY	Conc. CY
C	8	0.30
D	9	0.36
E	9	0.37
H	11	0.45

NOTES:

1. Concrete Apron to be installed only where called for in the Plans.
2. Sod always required.



SECTION AA-AA



SECTION BB-BB

TRAVERSABLE INLET WITHOUT SLOT DETAILS

8/28/2020 7:44:58 AM

LAST REVISION 11/01/20	REVISION	DESCRIPTION:
---------------------------	----------	--------------



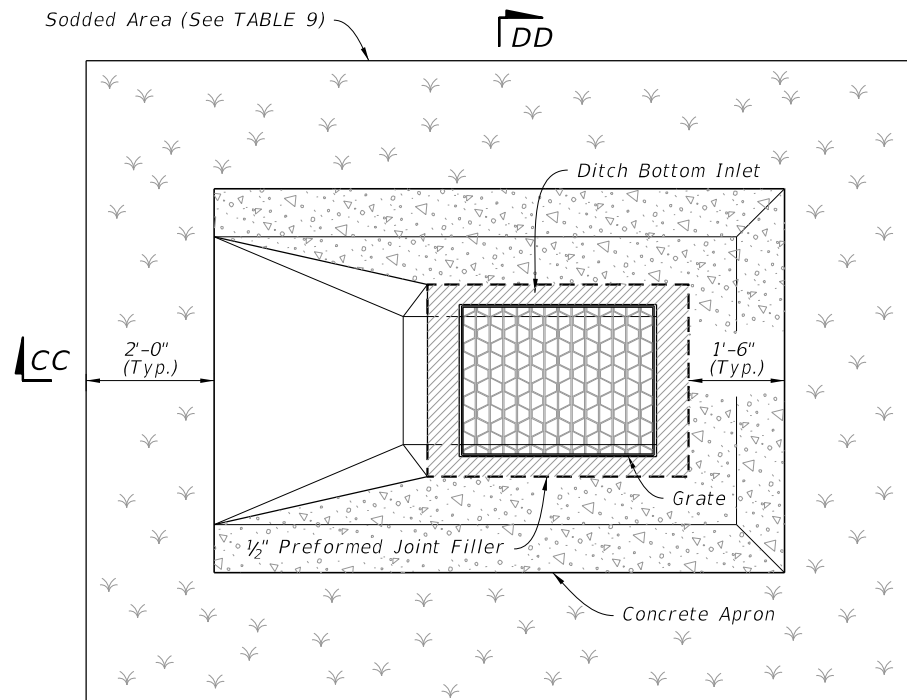
FY 2021-22
STANDARD PLANS

DITCH BOTTOM INLET TYPE C, D, E, AND H

INDEX
425-052

SHEET
9 of 14

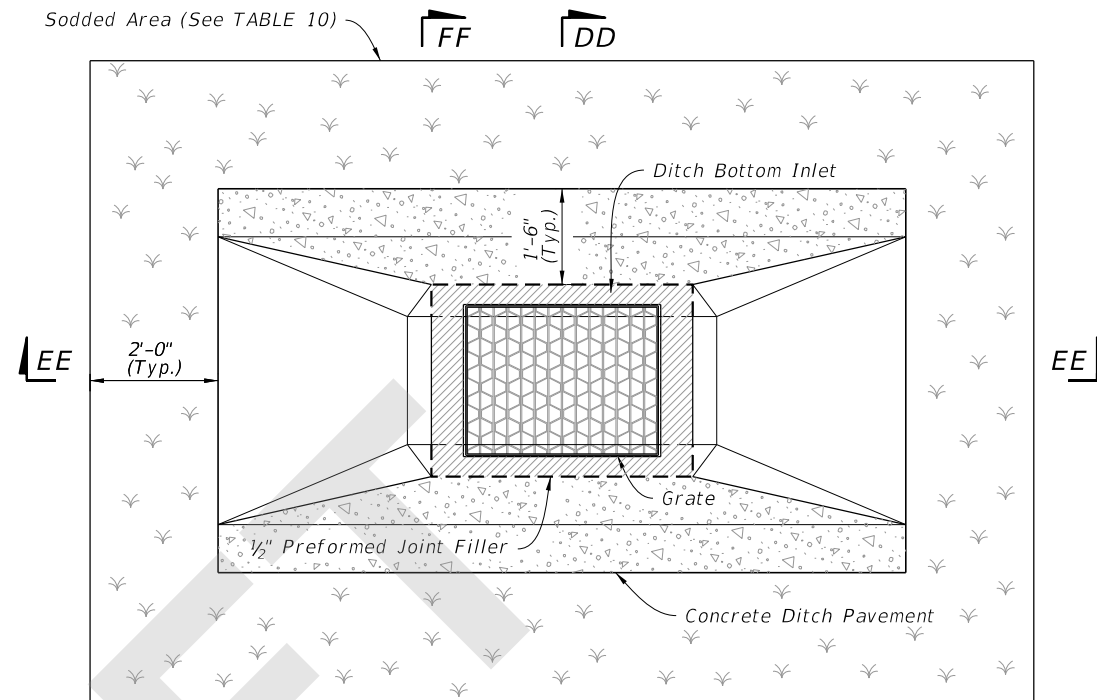
Sodded Area (See TABLE 9)



**TABLE 9
CONCRETE APRON
AND
SOD QUANTITIES**

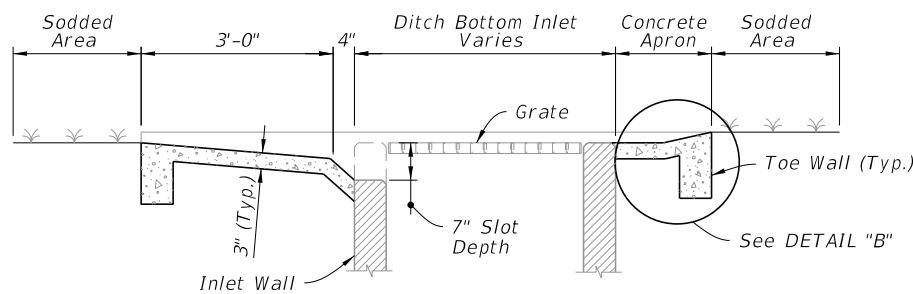
SINGLE SLOT		
Inlet Type	Sod SY	Conc. CY
C	12	0.77
D	14	0.91
E	14	0.91
H	--	--

Sodded Area (See TABLE 10)

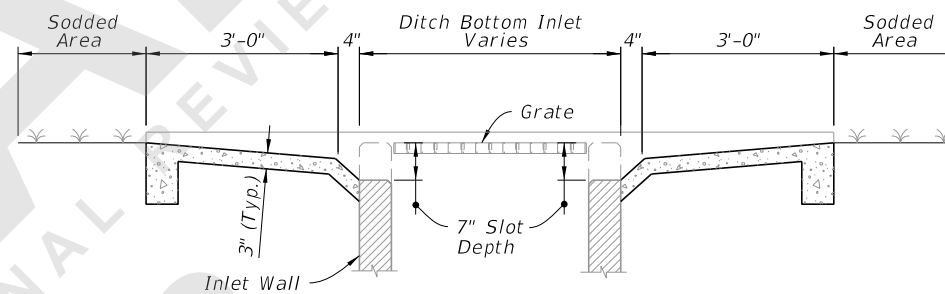


**TABLE 10
CONCRETE APRON
AND
SOD QUANTITIES**

SINGLE SLOT		
Inlet Type	Sod SY	Conc. CY
C	16	0.93
D	19	1.10
E	18	1.08
H	--	--



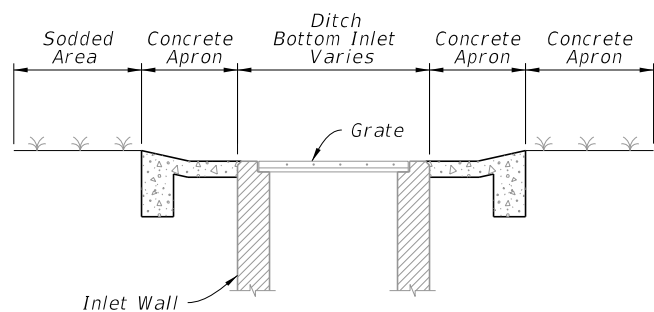
SECTION CC-CC



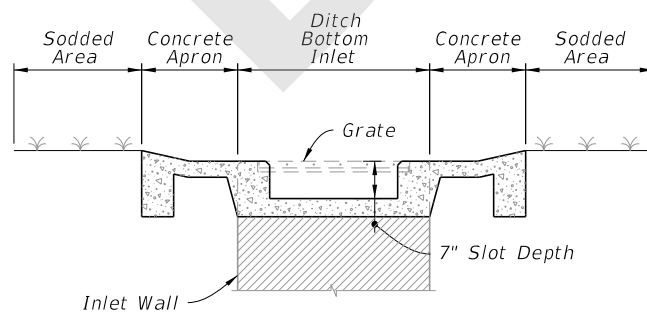
SECTION EE-EE

SINGLE SLOT

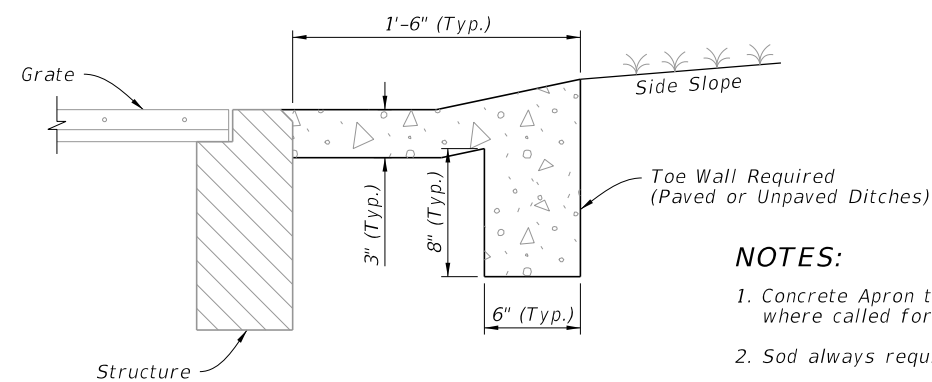
DOUBLE SLOT



SECTION DD-DD



SECTION FF-FF



DETAIL "B"

NOTES:

1. Concrete Apron to be installed only where called for in the Plans.
2. Sod always required.

8/28/2020 7:45:00 AM

LAST REVISION	DESCRIPTION:
11/01/20	



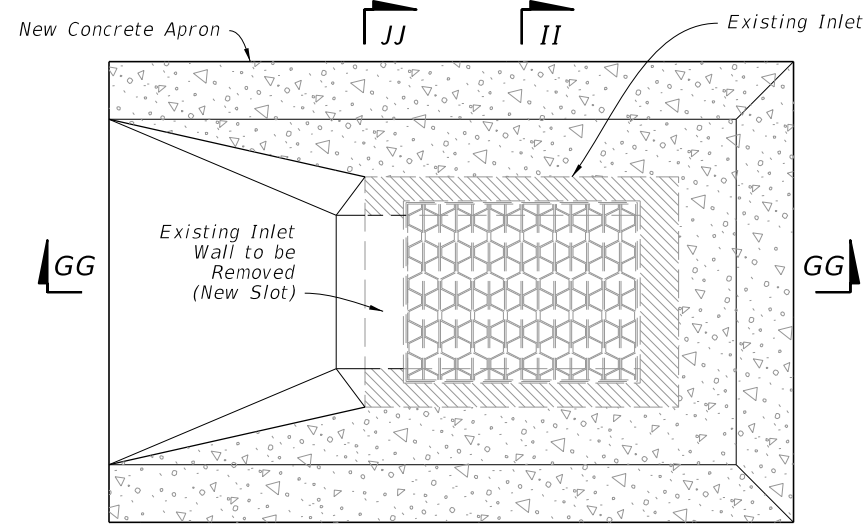
FY 2021-22
STANDARD PLANS

DITCH BOTTOM INLET TYPE C, D, E, AND H

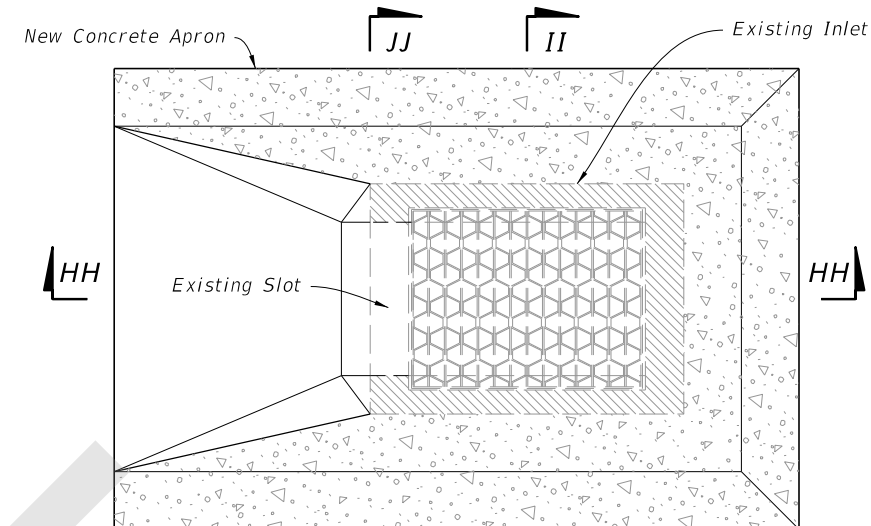
INDEX
425-052

SHEET
10 of 14

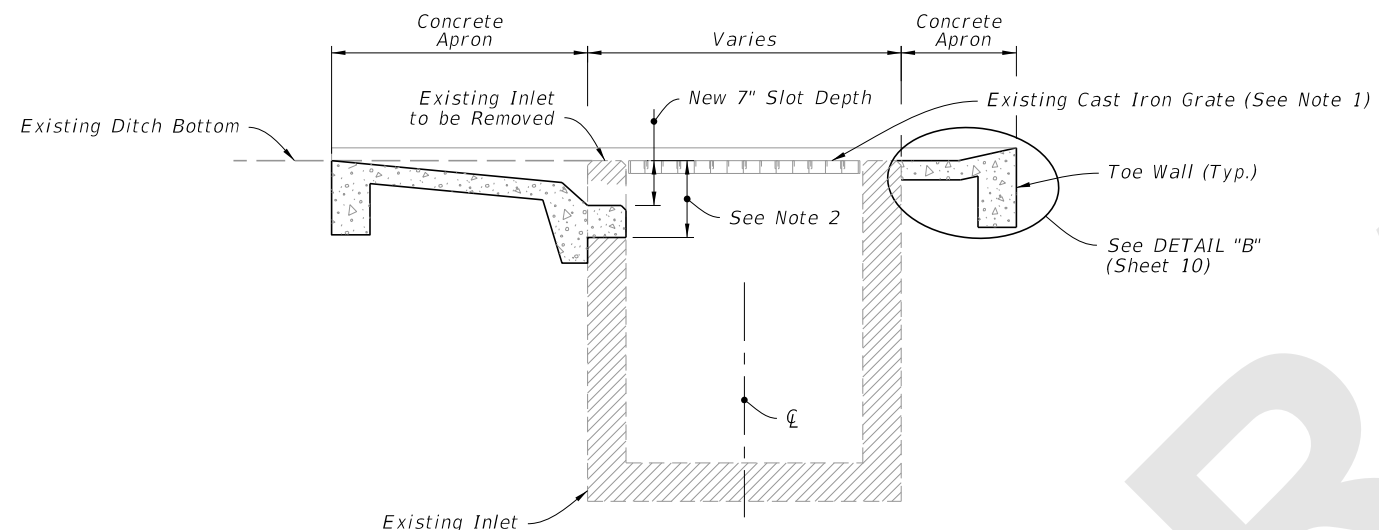
TRAVERSABLE INLET WITH SLOT DETAILS



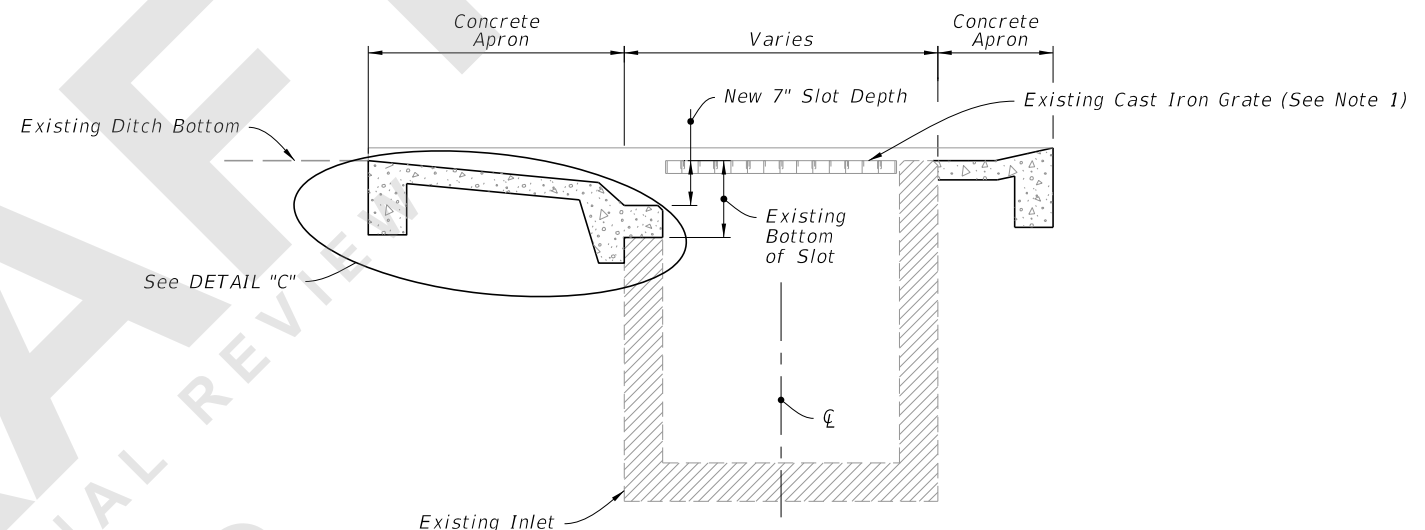
PLAN



PLAN



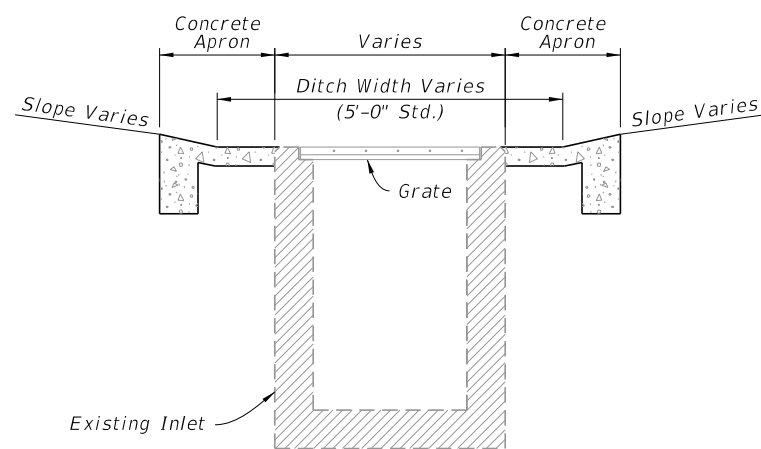
SECTION GG-GG



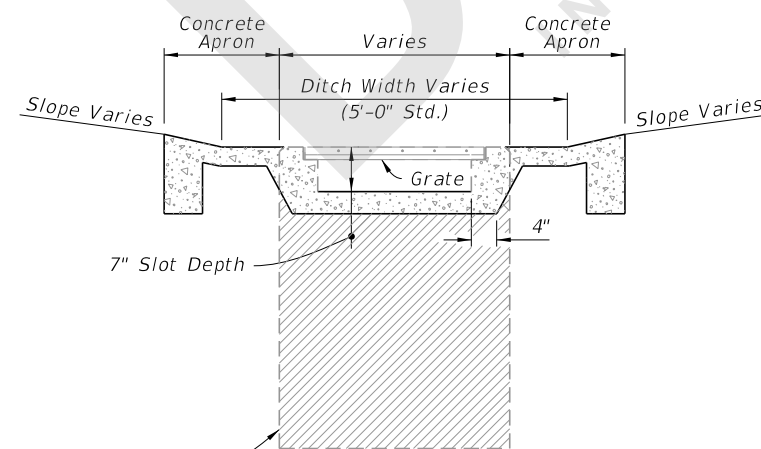
SECTION HH-HH

WITHOUT SLOT

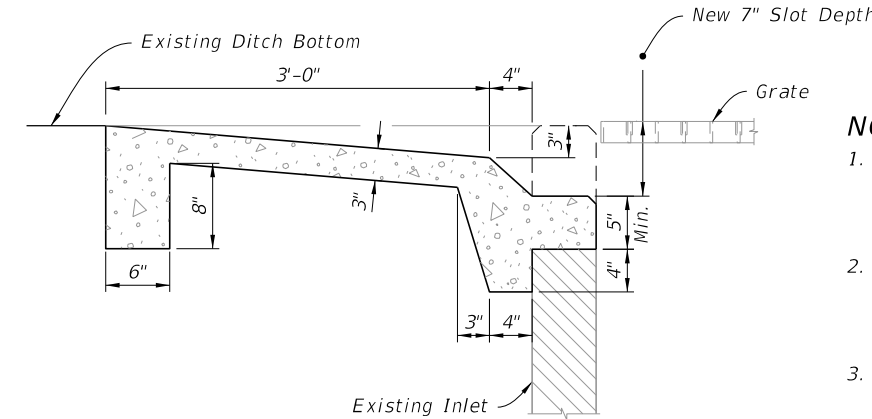
WITH SLOT



SECTION II-II



SECTION JJ-JJ



DETAIL "C"

NOTES:

1. Replace existing cast iron grate with steel grate. Replace existing steel grate when called for in the plans or as directed by the Engineer.
2. Remove existing wall to this line (exposed rebar in pavement zone may be either removed or embedded)
3. Single Slot shown, Double Slots symmetrical about the Inlet centerline.

CASE 1 - ADD TRAVERSABLE SLOTS TO EXISTING INLETS

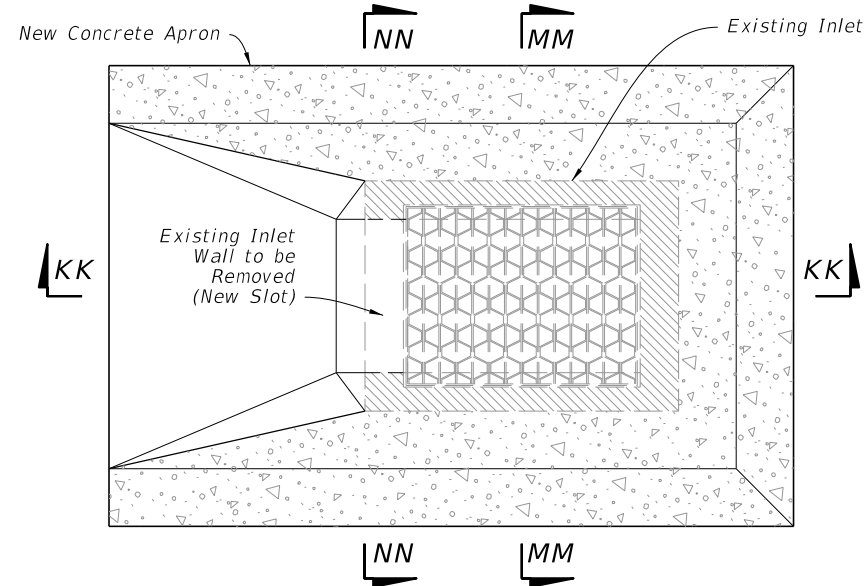
8/28/2020 7:45:04 AM

LAST REVISION 11/01/20	DESCRIPTION:
---------------------------	--------------

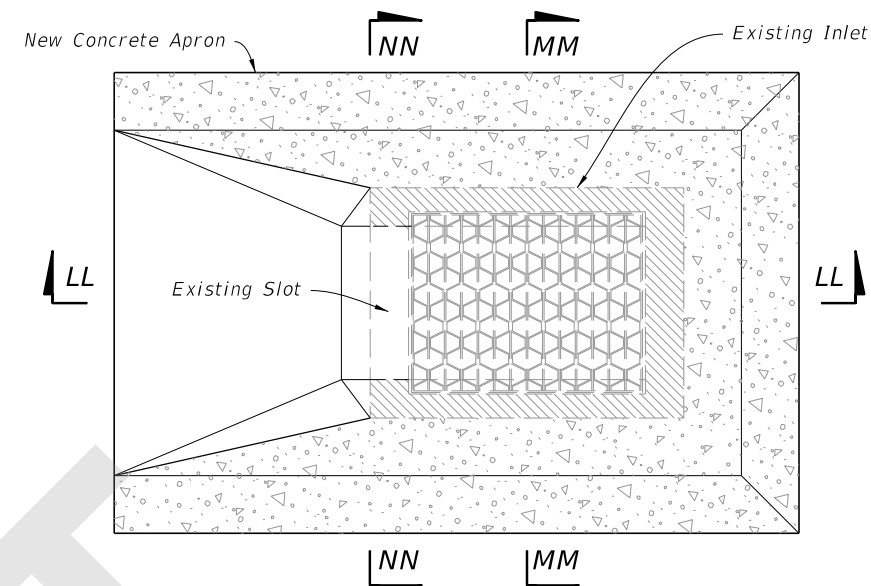

**FY 2021-22
STANDARD PLANS**

DITCH BOTTOM INLET TYPE C, D, E, AND H

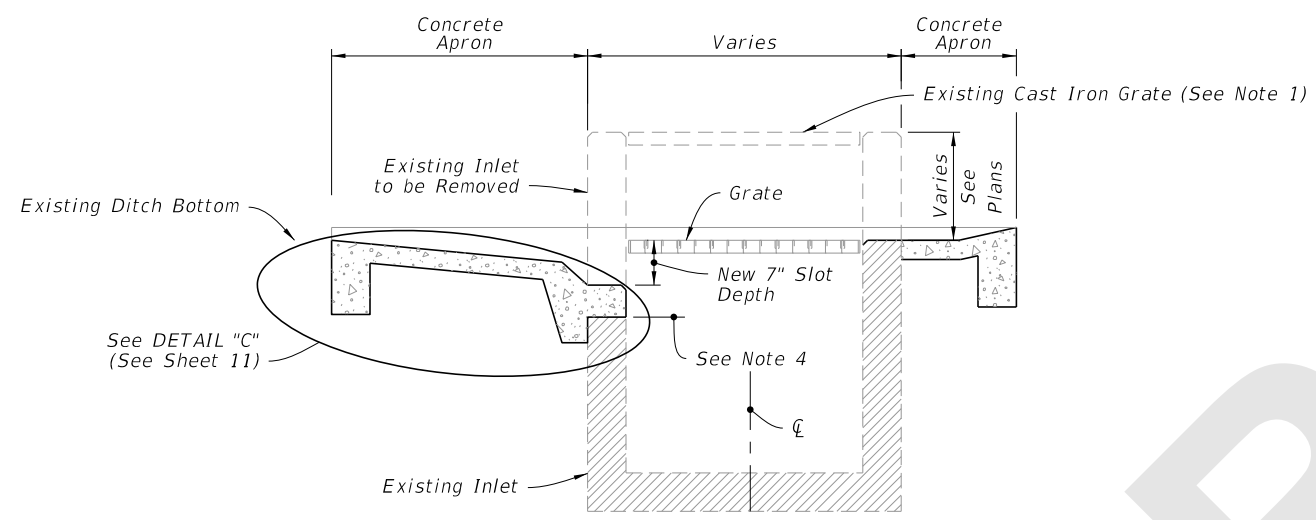
INDEX 425-052	SHEET 11 of 14
------------------	-------------------



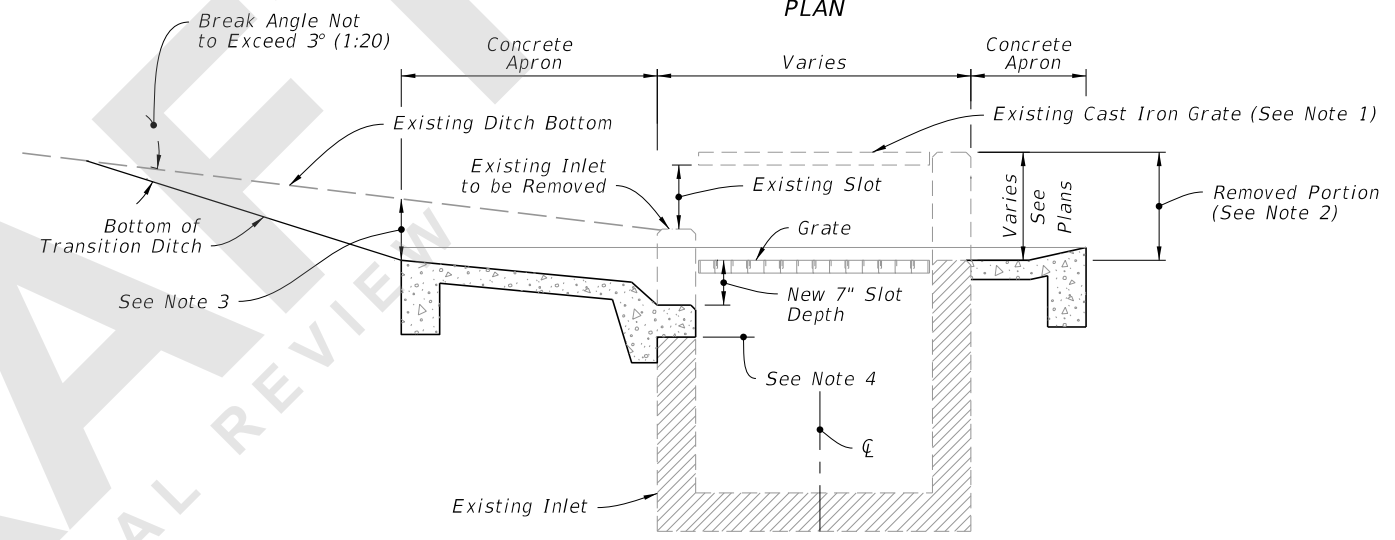
PLAN



PLAN



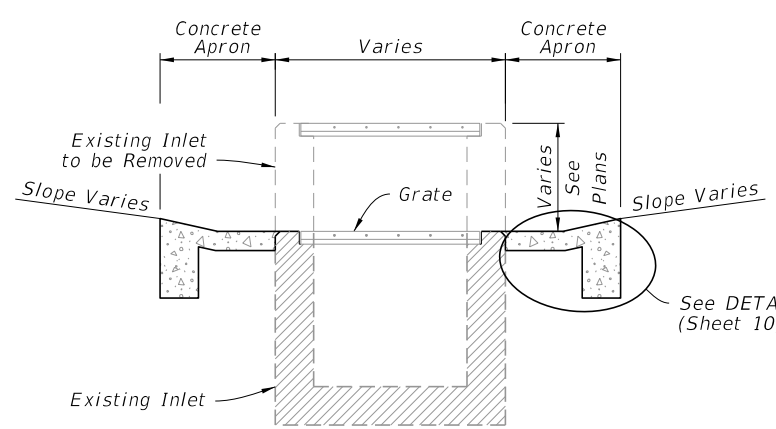
SECTION KK-KK



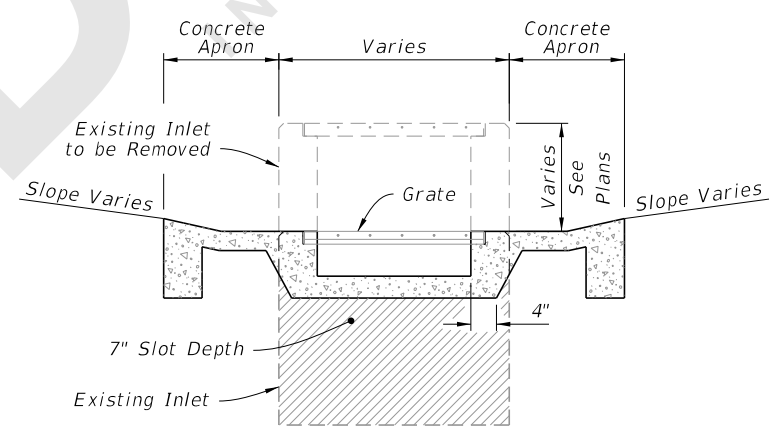
SECTION LL-LL

WITHOUT SLOT

WITH SLOT



SECTION MM-MM



SECTION NN-NN

NOTES:

- Existing cast iron grate to be replaced with steel grate. Existing steel reticulate grate to be replaced when called for in the Plans or as directed by the Engineer.
- Remove this portion of box and construct new, concrete ditch pavement, seats and slot (s) (slots if required).
- These points can be the same or nearly the same where ditch grades are flat.
- Remove exist. wall to this line (exposed rebar in part. zone may be either removed or embedded).
- Single Slot shown, Double Slots symmetrical about the Inlet centerline.

CASE 2 - ADD TRAVERSABLE SLOTS (PARTIAL) TO EXISTING INLETS

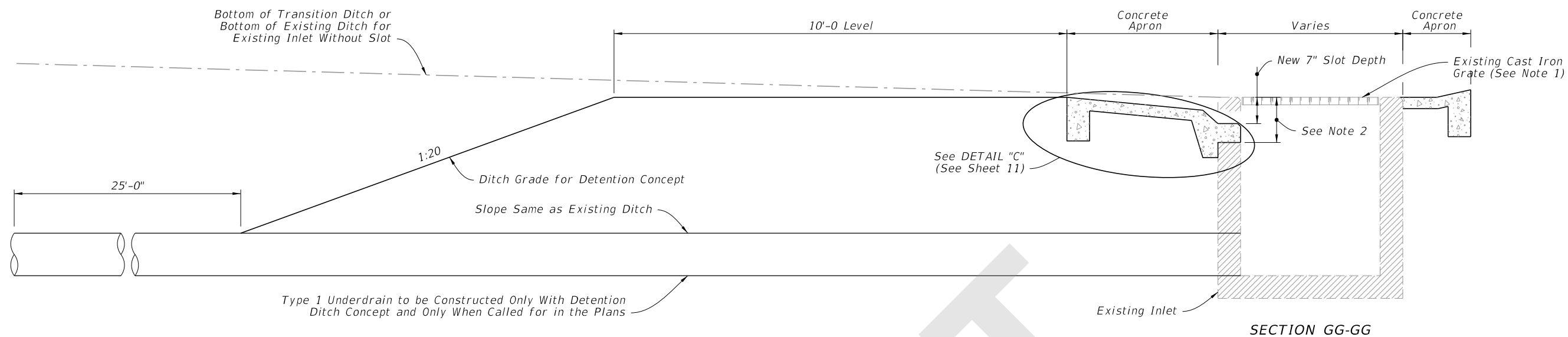
8/28/2020 7:45:06 AM

LAST REVISION 11/01/20	DESCRIPTION:
---------------------------	--------------

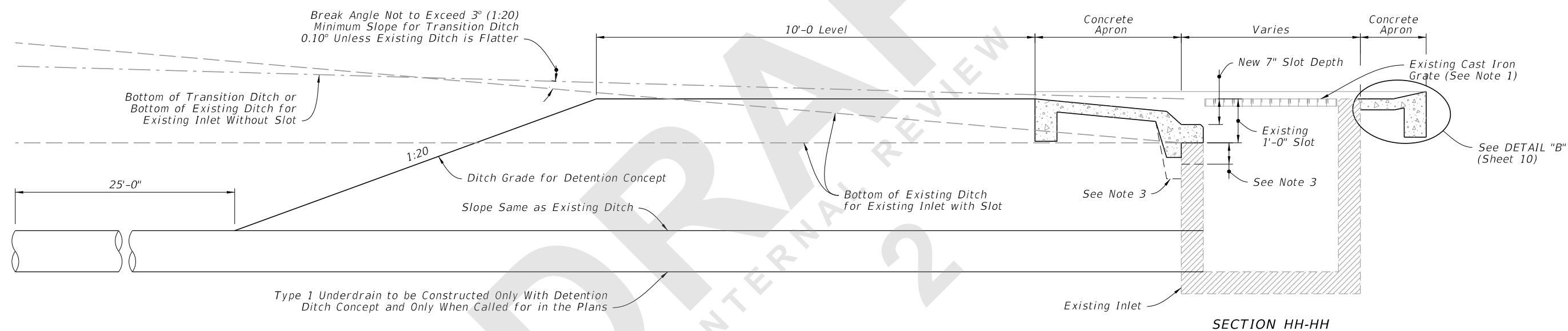

**FY 2021-22
STANDARD PLANS**

DITCH BOTTOM INLET TYPE C, D, E, AND H

INDEX 425-052	SHEET 12 of 14
------------------	-------------------



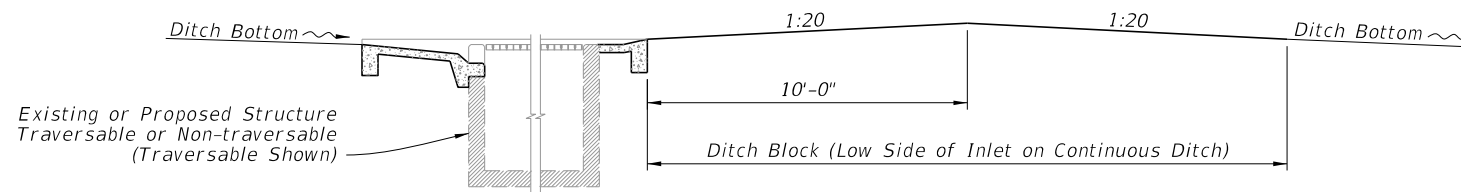
WITHOUT SLOT



WITH SLOT

NOTES:


1. Existing cast iron grate to be replaced with steel grate. Existing steel reticuline grate to be replaced when called for in the Plans or as directed by the Engineer.
2. Remove existing wall to this line (exposed rebar in pavement zone may be either removed or embedded)
3. Install extra apron when existing slot exceeds 12" in depth.
4. Inlet details (With or Without Slots) similar to details on Sheet 11.

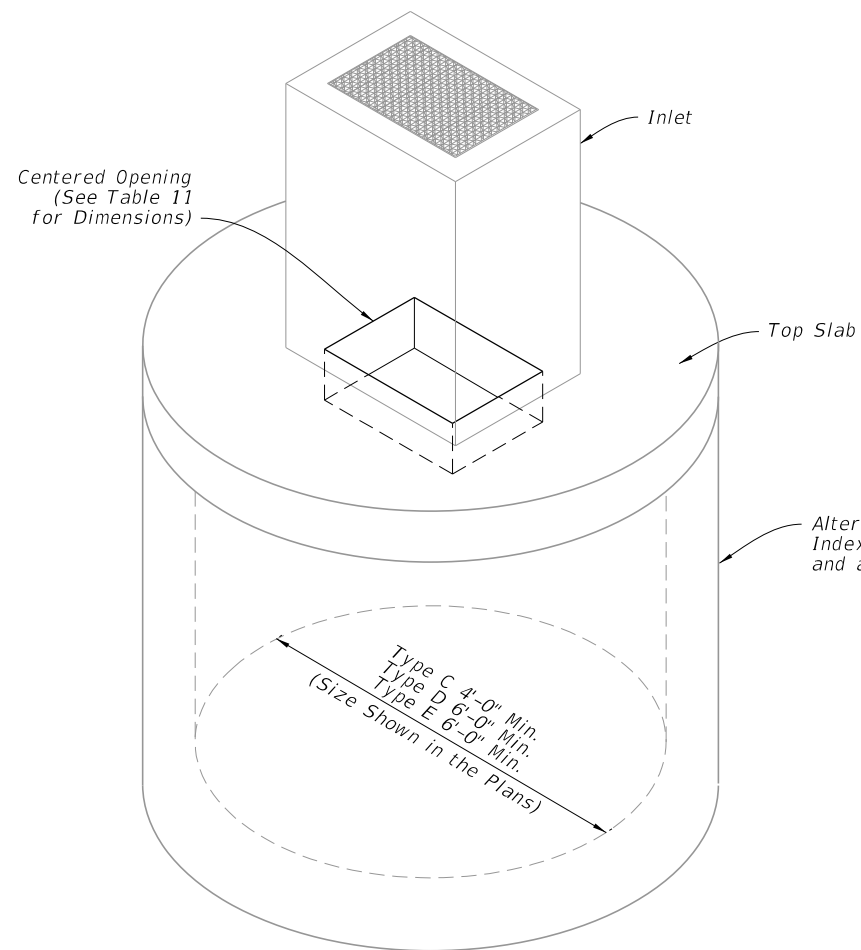


DITCH BLOCK FOR INLETS WITH OR WITHOUT SLOTS

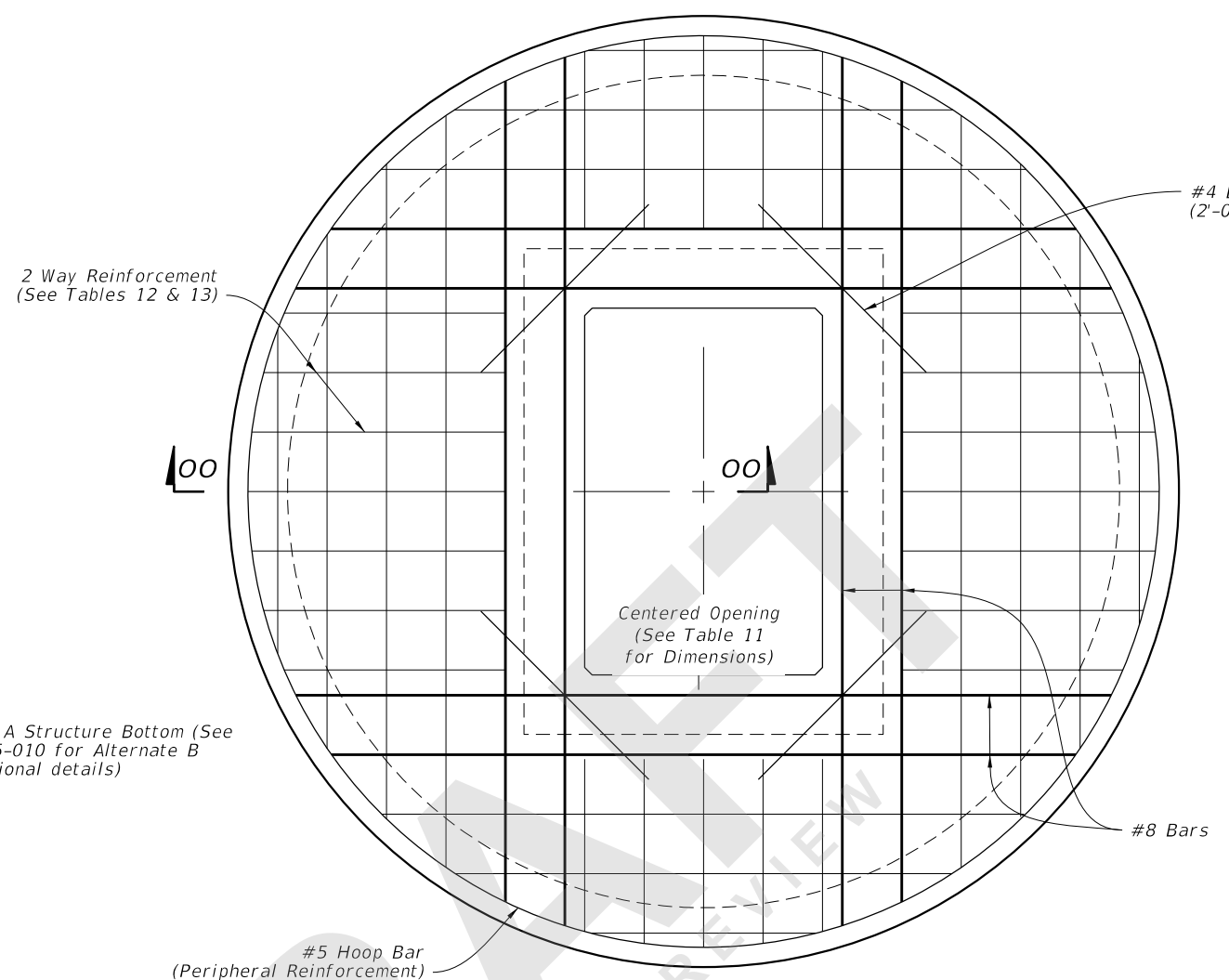
CASE 3 - ADD TRAVERSABLE SLOTS (PARTIAL) TO EXISTING INLETS AND DITCH BLOCK

8/28/2020 7:45:11 AM

LAST REVISION 11/01/20	REVISION	DESCRIPTION:	 FY 2021-22 STANDARD PLANS	DITCH BOTTOM INLET TYPE C, D, E, AND H	INDEX 425-052	SHEET 13 of 14
---------------------------	----------	--------------	---	--	------------------	-------------------

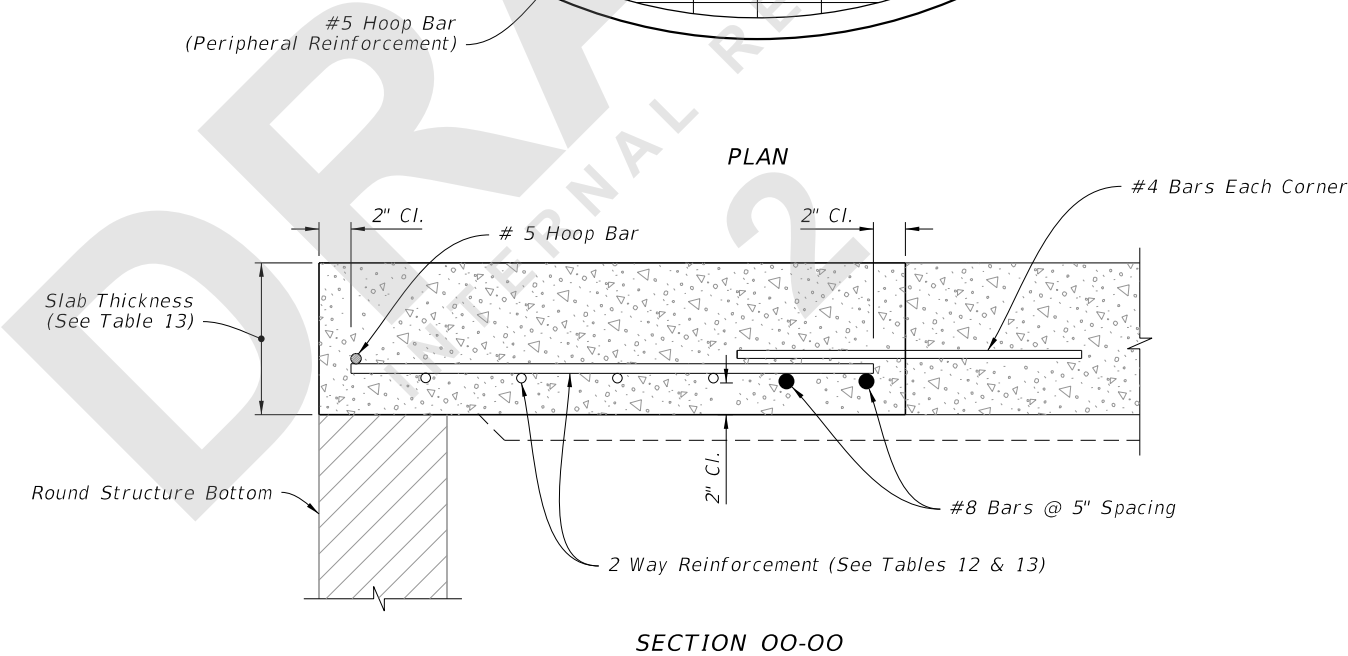


DIAMETER	OPENING SIZE	
	Min.	Max.
4'-0"	2'-0" x 3'-1"	2'-0" x 3'-1"
5'-0"	2'-0" x 3'-1"	3'-1" x 4'-1"
6'-0"	2'-0" x 3'-1"	3'-0" x 4'-6"
8'-0"	2'-0" x 3'-1"	3'-0" x 4'-6"



SCHEDULE	GRADE 60 (BAR) OR 65 KSI & 70 KSI (WIRE REINFORCING) In. ² /ft.
A	0.20
B	0.24
C	0.37
D	0.53
E	0.73
F	1.06
G	1.45

STRUCTURE DEPTH	SLAB THICKNESS	REINFORCING (2 WAY) SCHEDULE
SIZE: 4'-0"		
≥0.5' < 40'	9½"	B
SIZE: 5'-0"		
≥0.5' < 30'	9½"	C
30' - 40'	9½"	D
SIZE: 6'-0"		
≥0.5' < 8'	11½"	B
8' < 18'	11½"	C
18' < 30'	11½"	D
30' < 37'	11½"	E
37' - 40'	11½"	G
SIZE: 8'-0"		
≥0.5' < 9'	11½"	C
9' < 15'	11½"	D
15' < 23'	11½"	E
23' < 33'	11½"	E
33' - 40'	11½"	G



ISOMETRIC VIEW

TOP SLAB REINFORCEMENT DETAILS

ALTERNATE A STRUCTURE BOTTOM - TOP SLAB DETAILS

8/28/2020 7:45:13 AM

LAST REVISION	DESCRIPTION:
11/01/20	



FY 2021-22
STANDARD PLANS

DITCH BOTTOM INLET TYPE C, D, E, AND H

INDEX
425-052

SHEET
14 of 14