

---

## Index 425-001 Supplementary Details For Drainage Structures

### ORIGINATION

**Date:** 11-1-2019

**Name:** Rick Jenkins

**Phone:** 850 414-4355

**Email:** rick.jenkins@dot.state.fl.us

### COMMENTARY

Changed Title. Reorganized Details and Sheets to declutter Index. Moved information from detail callouts to Notes in order to decrease clutter of the drawing. Design notes moved to SPI. Removed dimension "H" from SEGMENTS FOR SLAB TO WALL DOWEL CONSTRUCTION JOINTS OR MONOLITHIC CAST to clarify that the values in Table 3 are for RISER SEGMENTS OTHER THAN DOWEL. Slab to Wall details from 425-010 added to Index.

### COMMENTS AND RESPONSES

**BLACK** = Internal Review Comments    **RED** = Standard Plans Response

**Name:** Ron Cox

**Date:** 8-13-2020

**COMMENT:** A lot of information is missing on sheet 8, which is the revision of sheet 3 of 5 of the old plan. The information RED lined as Table 6-4.2 in the Drainage Design Guide, which is current Table 3 and Table 4 "minimum structure sizes for single and multiple pipe connections per side for rectangular structures", does not exist in the Drainage Design Guide. I would suggest adding a NOTE on sheet 8 under Multiple Pipe Connections for Rectangular Structures, referencing the "Drainage Design Guide" for structure sizes for pipe connections.

**RESPONSE:** The "Minimum Wall Length (L) for number of Parallel Pipes" information that was deleted from Table 4 will be added to the DDG and referenced in the SPI. We will also reference table 6.4-2 in the SPI.

**No Change made to Index**

**Date:** 8-21-2020

**Name:** Thomas Frank

**Date:** 8-17-2020

**COMMENT:** 425-001, General Note 3: *For square or rectangular precast drainage structures, use either deformed or smooth WWR meeting the requirements of Specification 931 may be used.* Recommend removing either the word "use," or "may be used."

**RESPONSE:** Agreed

**Change made to Index:** General Note 3 will be revised to delete the term "may be used."

**Date:** 8-21-2020

**Name:** Nathaniel Pulido

**Date:** 8-27-2020

**COMMENT:** Why was the table for "Minimum wall length (L) for number of parallel pipes" removed? If removed, why is there still dimension line showing 'minimum wall length (L)' within the diagram for number of parallel pipes? (Sheet 8 of 8)

**RESPONSE:** This information is meant for designers, so the table is being moved to the Drainage Design Guide. Design information should be placed in design manuals, not the Standard Plans. We agree that the "minimum wall length (L)" needs to be deleted.

**Change made to Index:** On sheet 8 of 8, removed the dimension (L) Wall Length and instead reference the Plans for wall length.

**Date:** 8-31-2020

**GENERAL NOTES:**

1. Use a 1-piece cover, unless the 2-piece cover is called for in the Plans, except at inlets and manholes with sump bottoms. Use the 2-piece cover when the sump depth exceeds 2', unless otherwise noted.
2. Include "Adjustable" on the cover for Type I manhole adjustable frames.
3. For square or rectangular precast drainage structures, use either deformed or smooth WWR meeting the requirements of Specification 931. WWR must be continuous around the box and lapped in accordance with Option 1 or 3 as shown in the Wall Reinforcing Splice Details.
4. Lap splice horizontal steel in the walls of rectangular structures in accordance with Option 1, 2 or 3 as shown in the Wall Reinforcing Splice Details.
5. Welding of splices and laps is permitted. Use AASHTO M259 requirements and restrictions on welds.
6. Rebar straight end embedment of peripheral reinforcement may be used in lieu of ACI standard hooks for top and bottom slabs, except when hooks are specifically called for in the Plans.
7. Precast opening for pipe must be the pipe OD plus 6" ( $\pm 2"$  tolerance). Use mortar to seal the pipe into the opening of such a mix that shrinkage will not cause leakage into or out of the structure. Dry-pack mortar may be used to seal openings less than 2½" wide.

TABLE OF CONTENTS:	
Sheet	Description
1	General Notes, Contents, Manhole Top Overview, and Manhole Covers
2	Manhole Frames and Manhole Tops
3	Inlet Locking Grates, Subgrade and Base Temporary Drains, and Pipe to Structure Filter Fabric Wrap
4	Drainage Structure Invert, Sump Bottom, Wall Reinforcing Splice Details, and Typical Slab to Wall Details
5	Precast Option and Equivalent Reinforcement substitution
6	Construction Joints and Minimum Box Riser Segment Dimensions
7	Skewed Pipe in Rectangular Structures
8	Miscellaneous Pipe Connection Details

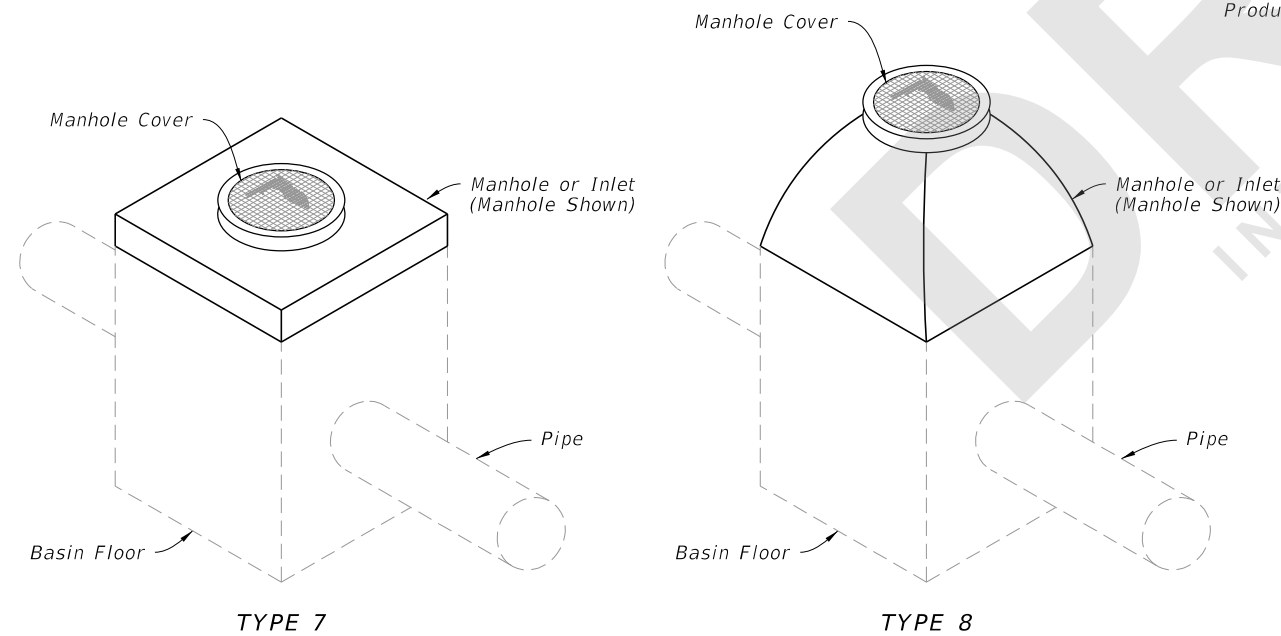
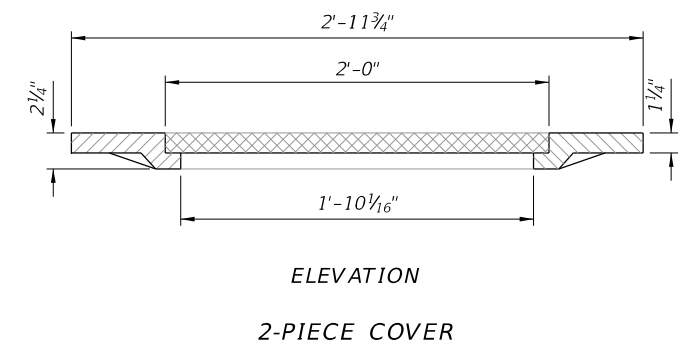
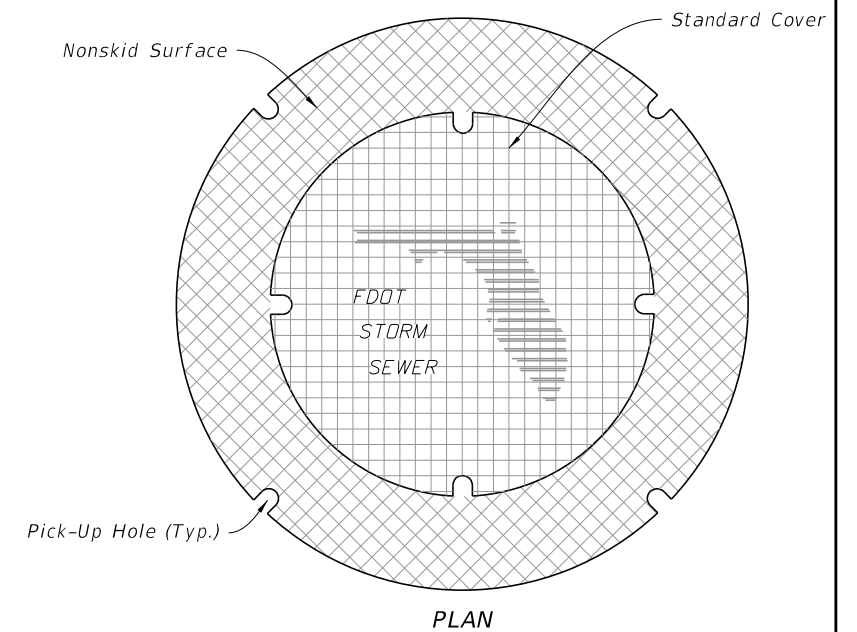
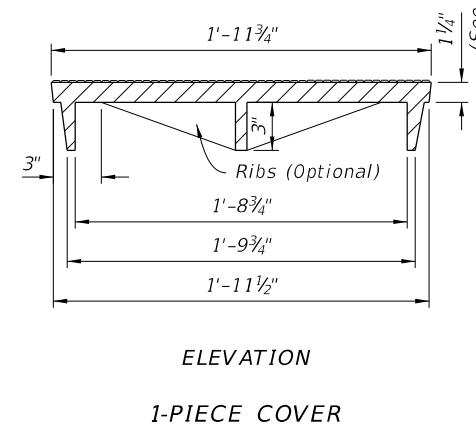
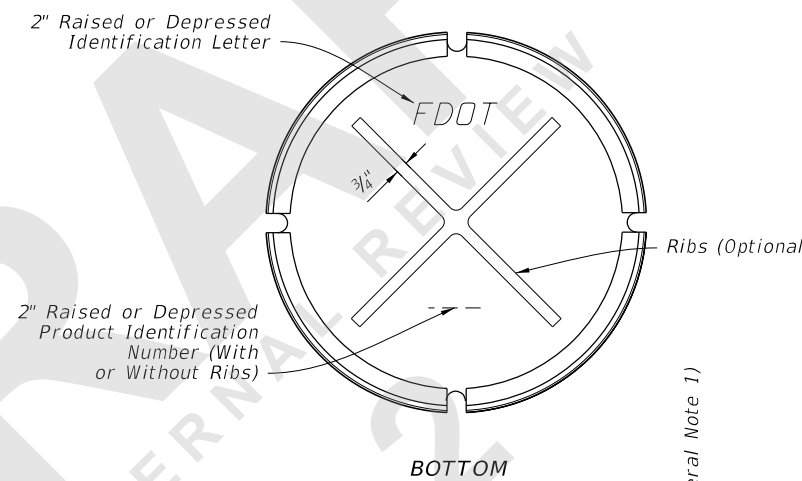
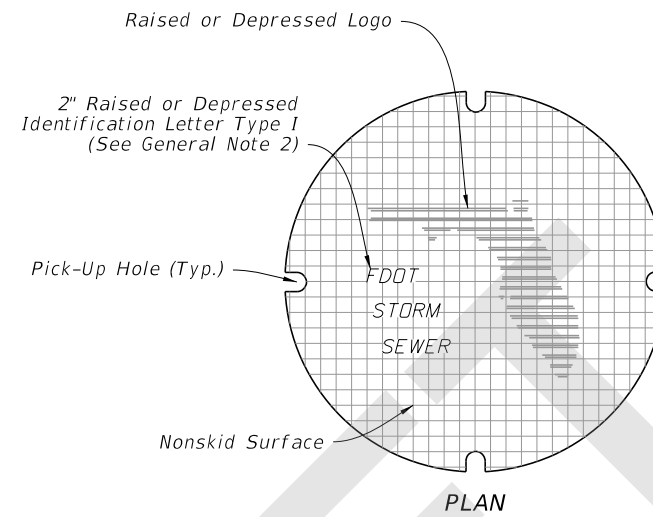

MANHOLE TOPS

MANHOLE COVERS

8/28/2020 1:30:16 PM

LAST REVISION 11/01/20

DESCRIPTION:



FY 2021-22  
STANDARD PLANS

SUPPLEMENTARY DETAILS  
FOR DRAINAGE STRUCTURES

INDEX  
425-001

SHEET  
1 of 8

Frame Type	2'-0" OPENING		3'-0" OPENING			
	Frame	Cover (Std.)	Frame	2-Piece Cover		Total
			Inside	Outside		
I	155	190	220	190	220	410
II	145	190	255	190	220	410
III	90	190	180	190	220	410

**NOTE:**  
Frame Type I in Table 1, includes Adjustable frames.

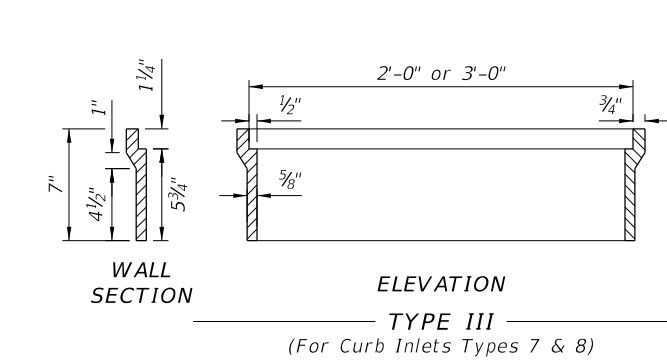
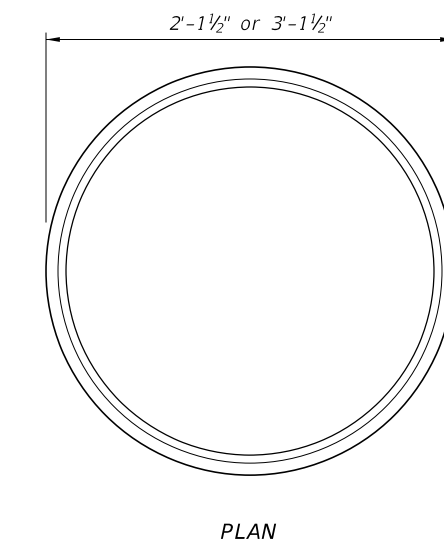
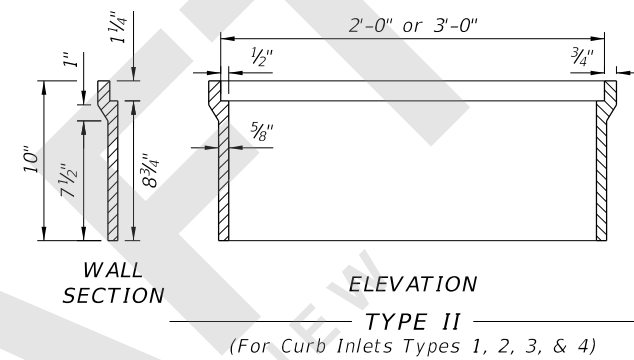
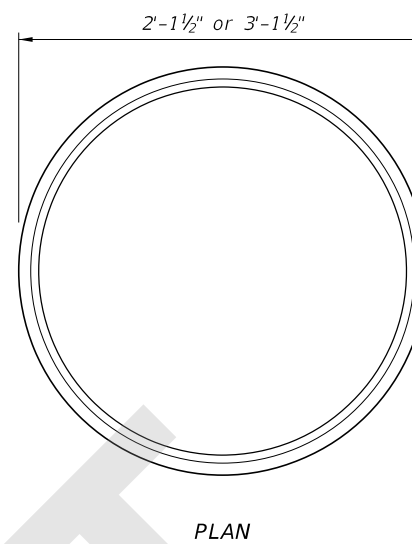
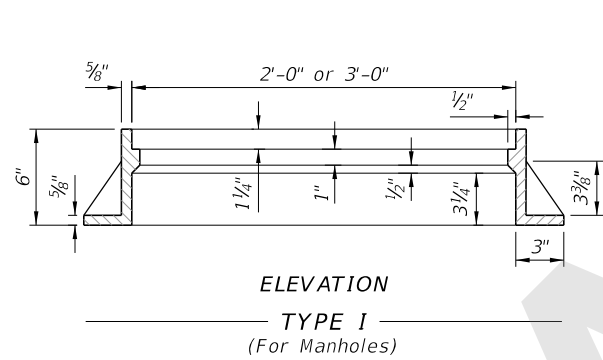
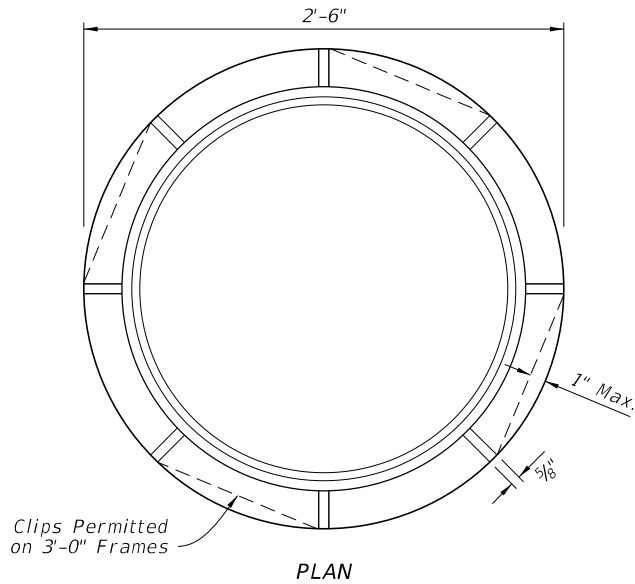

**MANHOLE FRAMES**

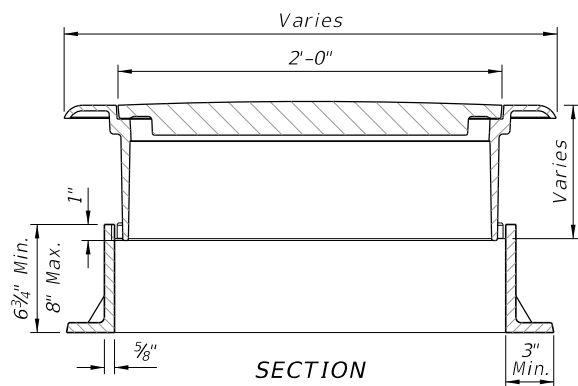

TYPE I ADJUSTABLE FRAME

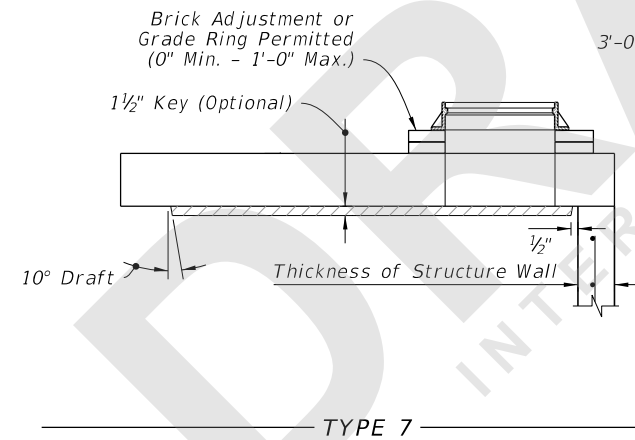

TYPE 7

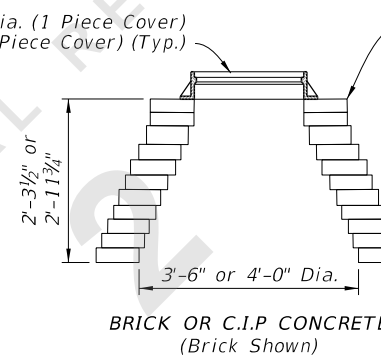

BRICK OR C.I.P. CONCRETE (Brick Shown)

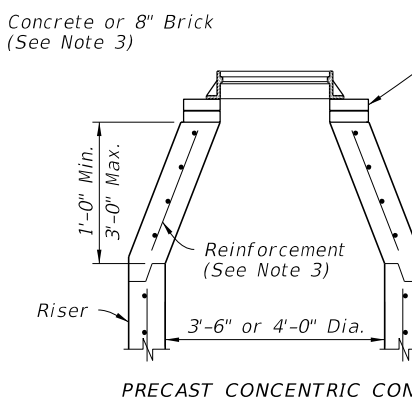

PRECAST CONCENTRIC CONE

TYPE 8

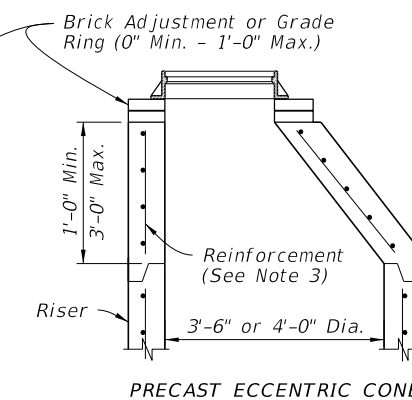

PRECAST ECCENTRIC CONE

**NOTES:**

1. Use Class II concrete for Manhole top Type 7 slabs, see General Note 6.
2. Manhole top Type 7 slabs may be of cast-in-place or precast construction. The optional key is for precast tops and in lieu of dowels. Omit frame and slab openings when top is used over a junction box.
3. Manhole top Type 8 may be of cast-in-place, precast concrete construction, or brick construction. For concrete construction, use the same concrete and steel reinforcement as the supporting wall unit. An eccentric cone may be used.
4. Use optional construction joints as shown on Sheet 6 to secure manhole tops to structures.
5. Frames may be adjusted to a maximum 12" height with brick or precast ASTM C478 grade rings.
6. Manhole top Type 8 may be substituted for a Type 7, if the minimum dimensions are not reduced.
7. Manhole top Type 7 may be substituted for Type 8, if the minimum thickness (h) above pipe opening cannot be maintained with Type 8.

**MANHOLE TOPS**

**MANHOLE FRAMES AND MANHOLE TOPS**

8/28/2020 1:30:18 PM

LAST REVISION 11/01/20	DESCRIPTION:
---------------------------	--------------

**FDOT** FY 2021-22 STANDARD PLANS

SUPPLEMENTARY DETAILS FOR DRAINAGE STRUCTURES

INDEX  
425-001

SHEET  
2 of 8

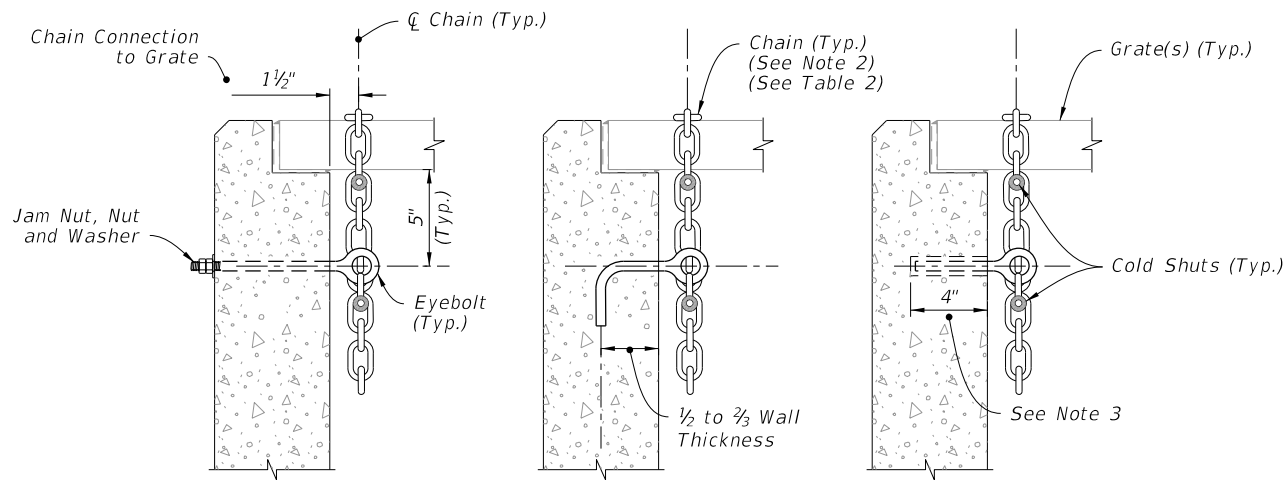

THRU-BOLT

J-TYPE

ADHESIVE BONDED ANCHOR

NOTES:

1. Install either a 1/2" Ø x 1" Diameter Threaded Straight (Thru-Bolt), a J-Type, or an adhesive Bonded Anchor Eyebolt.
2. Install a 3/16" Chain and 3/16" Cold Shuts. When chaining two grates together provide adequate loop for easy handling.
3. Install adhesive bonded anchor option with a minimum of 4" embedment, and in accordance with Specification 416.

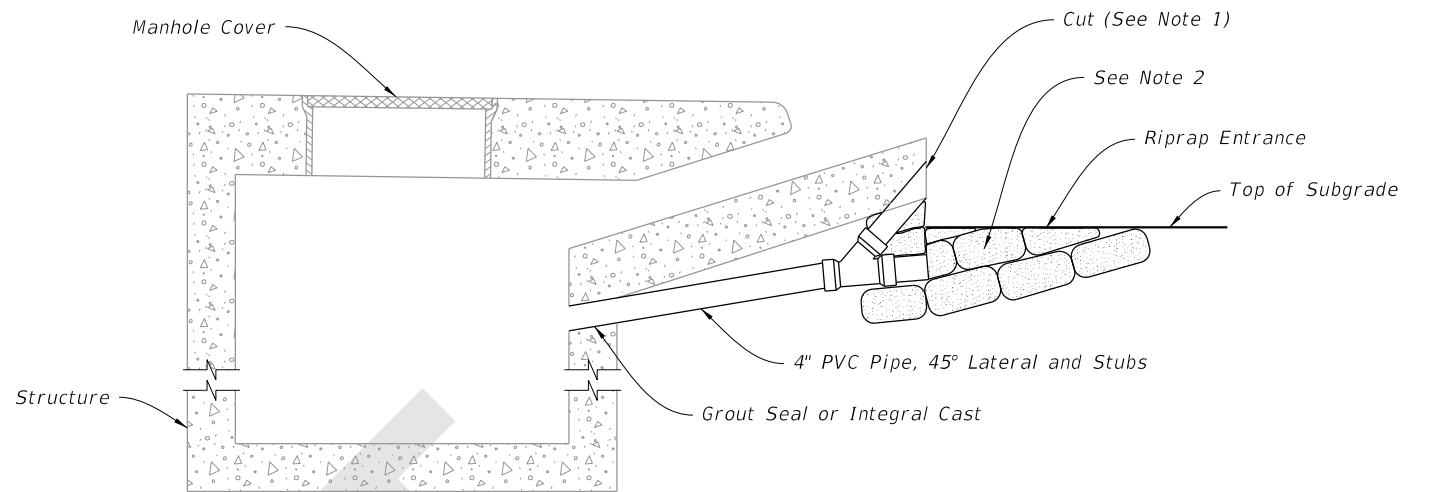

NOTES:

1. Bevel cut upper stub to match forming for apron face. Capping or plugging of upper stub is not required. Remove friable base material at stub opening to permit covering of opening with structural course material.
2. Remove riprap, cement PVC cap on lower stub, and place compacted fill in entrance prior to placing base material.

SUBGRADE AND BASE TEMPORARY DRAINS

Index Number	Inlet Type	Eye-Bolts	Length of Chain	Handling & Remarks
425-030	1	1	4'-0"	Slide & Spin
	2	1	4'-0"	Slide & Spin
	3	2	2 @ 4'-0"	Slide & Spin
	4	2	2 @ 4'-0"	Slide & Spin
	5	2	2 @ 4'-0"	Slide & Spin
425-031	N/A	1	3'-8"	Slide or Slide & Spin
425-032	N/A	1	4'-0"	Slide & Spin
425-040	S	1	4'-0"	Slide & Spin
425-041	V	1	4'-0"	Slide & Spin
425-050	A	1	3'-0"	Slide
425-051	B	1	5'-0"	Slide & Spin
	C	1	2'-6"	Slide & Spin
	D	1	2'-6"	Slide & Spin
	E	2	2 @ 2'-6"	Slide & Spin
425-052	H	2	2 @ 2'-6"	Flip Ctr. Grate and Slide & Spin Single Free Grate
			1 or 2 @ 1'-6"	Center Grate(s) Chained to One End Grate
425-053	F	1	3'-6"	Flip or Slide & Spin
	G	1	6'-0"	Slide
			2'-0"	Lifting Loop
425-054	J	1	4'-0"	Slide & Spin

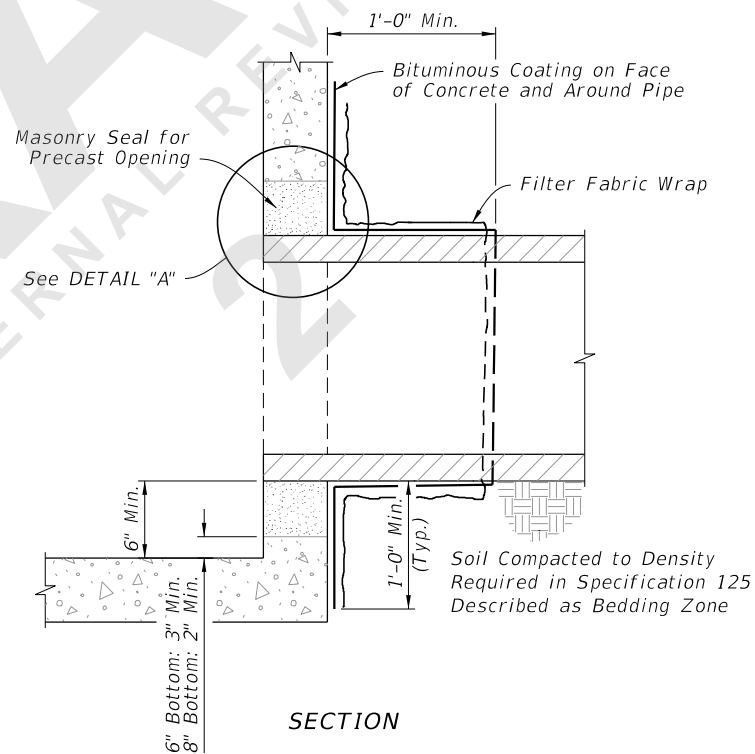

SECTION

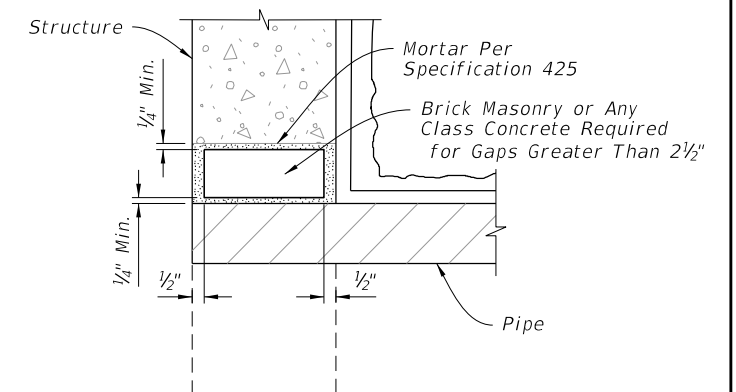

DETAIL "A"

LOCKING GRATES TO INLETS

PIPE TO STRUCTURE FILTER FABRIC WRAP

LOCKING GRATES, SUBGRADE AND BASE TEMPORARY DRAINS, AND PIPE TO STRUCTURE FILTER FABRIC WRAP

8/28/2020 1:30:23 PM

LAST REVISION 11/01/20	DESCRIPTION:	FDOT FY 2021-22 STANDARD PLANS	SUPPLEMENTARY DETAILS FOR DRAINAGE STRUCTURES	INDEX 425-001	SHEET 3 of 8
---------------------------	--------------	--------------------------------------	--	------------------	-----------------

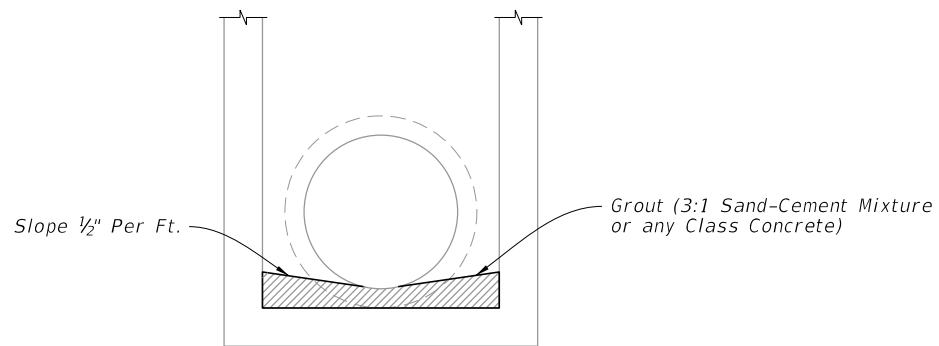

NOTE: For all structures unless excluded by special detail.

**DRAINAGE STRUCTURE INVERT**

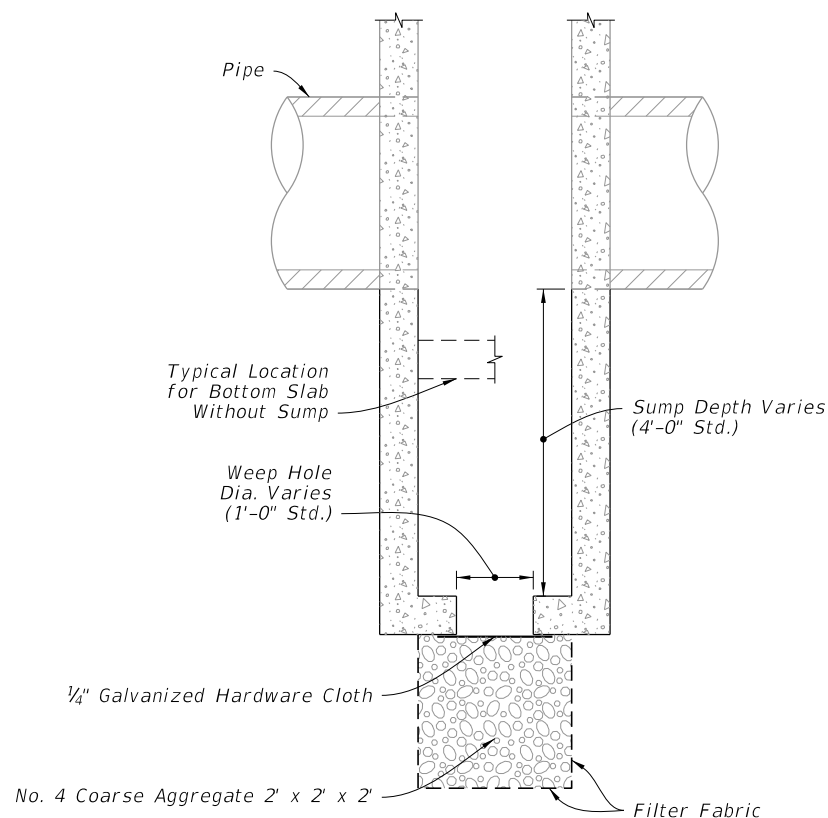

**NOTES:**

1. Construct sumps in inlets and manholes connecting to French Drains unless excluded in the Plans.
2. Construct sumps only where called for in the Plans at all other locations.
3. Construct weep holes in sump bottom only where called for in the Plans.

**SUMP BOTTOM**

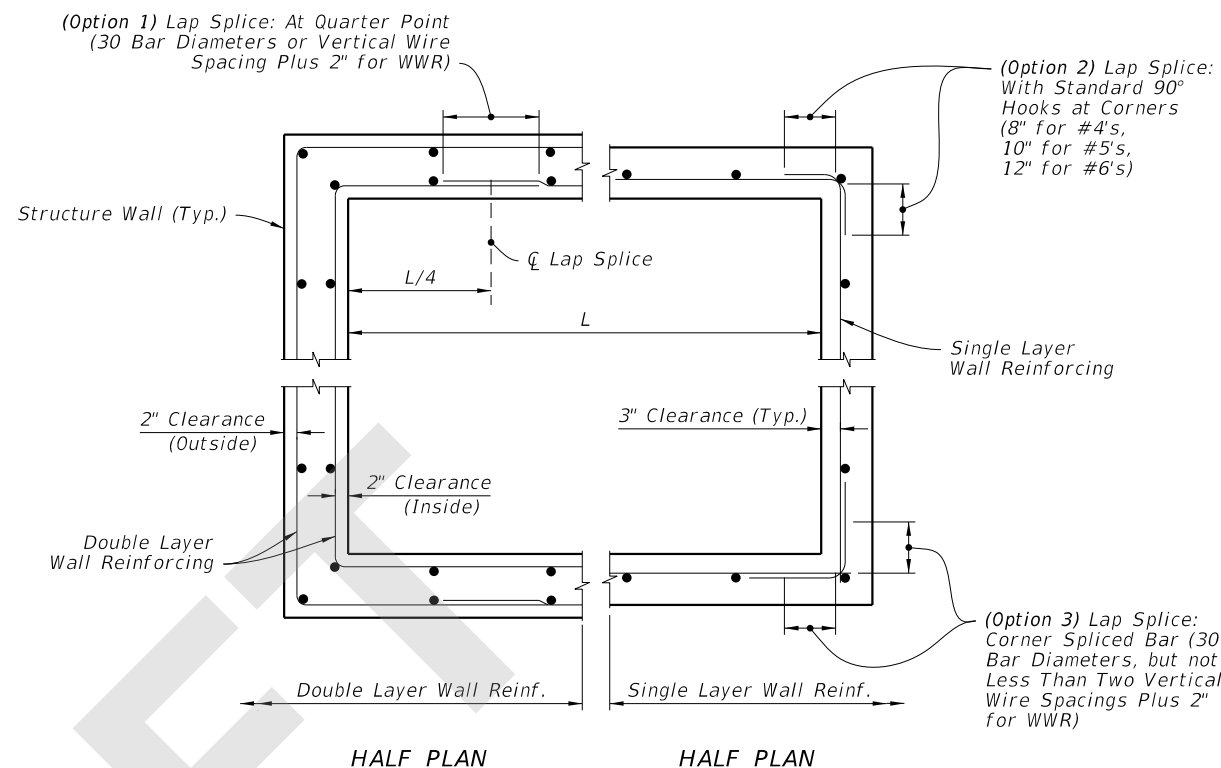

**WALL REINFORCING SPLICE DETAILS**

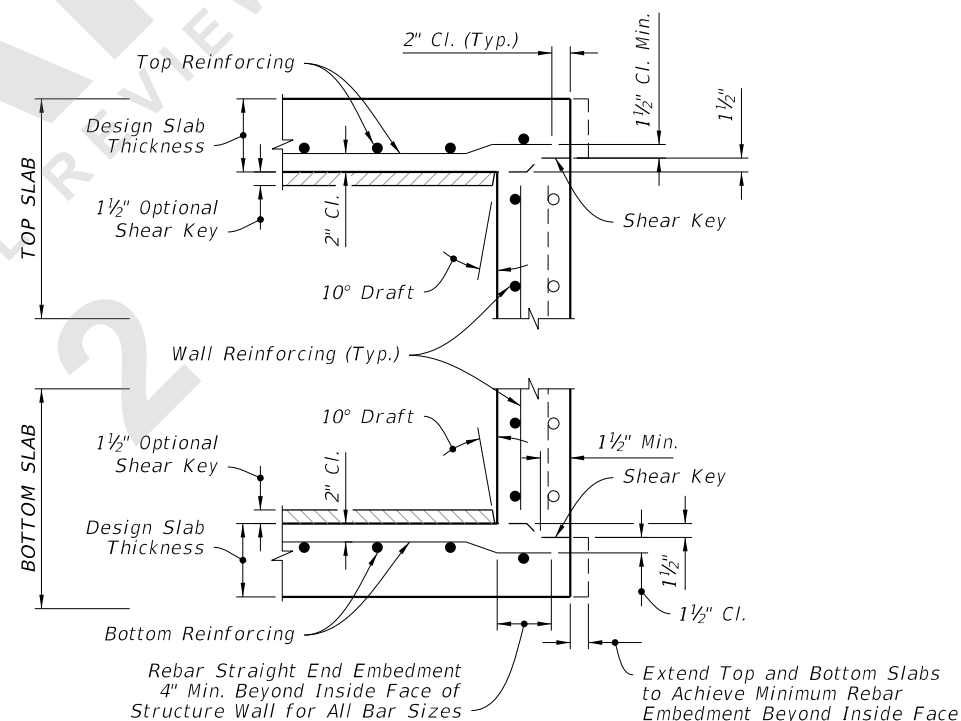

**NOTES:**

1. See Sheet 6 for optional construction joints.
2. Bend bars as required to maintain cover.

**TYPICAL SLAB TO WALL DETAILS  
(PRECAST STRUCTURE SHOWN)**

**DRAINAGE STRUCTURE INVERT, SUMP BOTTOM, WALL REINFORCING SPLICE DETAILS, AND TYPICAL SLAB TO WALL DETAILS**

8/28/2020 1:30:25 PM

LAST REVISION	DESCRIPTION:
11/01/20	



FY 2021-22  
STANDARD PLANS

SUPPLEMENTARY DETAILS  
FOR DRAINAGE STRUCTURES

INDEX  
425-001

SHEET  
4 of 8

8/28/2020 1:30:28 PM

**EXAMPLE TABLE OF EQUIVALENT STEEL AREA**

SCHEDULE	GRADE 60 REINFORCING BAR		EQUIVALENT GRADE 40 REINFORCING BAR		EQUIVALENT 65 KSI SMOOTH WELDED WIRE REINFORCEMENT		EQUIVALENT 70 KSI DEFORMED WELDED WIRE REINFORCEMENT	
	Bar Size & Spacing	Steel Area (in <sup>2</sup> /ft)	Bar Size & Spacing	Steel Area (in <sup>2</sup> /ft)	Style Designation	Steel Area (in <sup>2</sup> /ft)	Style Designation	Steel Area (in <sup>2</sup> /ft)
A	#3 @ 6½" Ctrs. #4 @ 12" Ctrs.	0.20	#3 @ 4½" Ctrs. #4 @ 8" Ctrs. #5 @ 12" Ctrs.	0.30	3"x3"-W4.6xW4.6 4"x4"-W6.2xW6.2 6"x6"-W9.2xW9.2	0.1846	3"x3"-D4.3xD4.3 4"x4"-D5.7xD5.7 6"x6"-D8.6xD8.6	0.1714
B	#3 @ 5½" Ctrs. #4 @ 10" Ctrs.	0.24	#3 @ 3½" Ctrs. #4 @ 6½" Ctrs. #5 @ 10" Ctrs.	0.36	3"x3"-W5.5xW5.5 4"x4"-W7.4xW7.4 6"x6"-W11.1xW11.1	0.2215	3"x3"-D5.1xD5.1 4"x4"-D6.9xD6.9 6"x6"-D10.3xD10.3	0.2057
Special 1	#3 @ 5" Ctrs. #4 @ 9" Ctrs.	0.267	#3 @ 3" Ctrs. #4 @ 6" Ctrs. #5 @ 9" Ctrs.	0.40	3"x3"-W6.2xW6.2 4"x4"-W8.2xW8.2 6"x6"-W12.3xW12.3	0.2465	3"x3"-D5.7xD5.7 4"x4"-D7.6xD7.6 6"x6"-D11.4xD11.4	0.2289
C	#3 @ 3½" Ctrs. #4 @ 6½" Ctrs. #5 @ 10" Ctrs.	0.37	#4 @ 4" Ctrs. #5 @ 6½" Ctrs. #6 @ 9½" Ctrs.	0.555	3"x3"-W8.5xW8.5 4"x4"-W11.4xW11.4 6"x6"-W17.1xW17.1	0.3415	3"x3"-D7.9xD7.9 4"x4"-D10.6xD10.6 6"x6"-D15.9xD15.9	0.3171
D	#4 @ 4½" Ctrs. #5 @ 7" Ctrs. #6 @ 10" Ctrs.	0.53	#4 @ 3" Ctrs. #5 @ 4½" Ctrs. #6 @ 6½" Ctrs.	0.795	3"x3"-W12.2xW12.2 4"x4"-W16.3xW16.3 6"x6"-W24.5xW24.5	0.4892	3"x3"-D11.4xD11.4 4"x4"-D15.1xD15.1 6"x6"-D22.7xD22.7	0.4543
E	#4 @ 3" Ctrs. #5 @ 5" Ctrs. #6 @ 7" Ctrs.	0.73	#5 @ 3½" Ctrs. #6 @ 4½" Ctrs. #7 @ 6½" Ctrs.	1.095	3"x3"-W16.8xW16.8 4"x4"-W22.5xW22.5 6"x6"-W33.7xW33.7	0.6738	3"x3"-D15.6xD15.6 4"x4"-D20.9xD20.9 6"x6"-D31.3xD31.3	0.6257
F	#5 @ 3½" Ctrs. #6 @ 5" Ctrs. #7 @ 7" Ctrs.	1.06	#6 @ 3" Ctrs. #7 @ 4½" Ctrs. #8 @ 6" Ctrs.	1.59	3"x3"-W24.5xW24.5 4"x4"-W32.6xW32.6 6"x6"-W48.9xW48.9	0.9785	3"x3"-D22.7xD22.7 4"x4"-D30.3xD30.3 6"x6"-D45.4xD45.4	0.9086
Special 2	#5 @ 3" Ctrs. #6 @ 4" Ctrs. #7 @ 5½" Ctrs.	1.24	#7 @ 4" Ctrs. #8 @ 5" Ctrs.	1.86	3"x3"-W28.6xW28.6 4"x4"-W38.2xW38.2 6"x6"-W57.2xW57.2	1.1446	3"x3"-D26.6xD26.6 4"x4"-D35.4xD35.4 6"x6"-D53.1xD53.1	1.0629
G	#6 @ 3½" Ctrs. #7 @ 5" Ctrs.	1.46	#7 @ 3" Ctrs. #8 @ 4" Ctrs.	2.19	3"x3"-W33.7xW33.7 4"x4"-W44.9xW44.9	1.3477	3"x3"-D31.3xD31.3 4"x4"-D41.7xD41.7	1.2514

**NOTES:**

1. See inlet indexes for optional precast inlet construction details up to depths of 15'.
2. Interior dimensions of an Alt. "B" Bottom may be adjusted to reflect these inlet interior dimensions when precast units are used in conjunction with Alt. "B" Structure Bottoms, Index 425-010.
3. Use concrete meeting the requirements of ASTM C478 or Class IV for precast structures with 6" wall or slab thickness.
4. Reinforcement may be deformed bar reinforcement or welded wire reinforcement. Bar reinforcement other than 60 ksi may be used, however only two grades are recognized: Grade 40 and Grade 60. Smooth welded wire reinforcement will be recognized as having a design strength of 65 ksi and deformed welded wire reinforcement will be recognized as having a design strength of 70 ksi. The area of reinforcement required may be adjusted in accordance with the Equivalent Steel Area Table provided. Use the following equations to determine the steel area and spacing for bars not otherwise specified:

Grade 40 Steel Area =  $A_{s40} = 60/40 \times A_{s60}$

Smooth Welded Wire Reinforcement Steel Area =  $A_{s65} = 60/65 \times A_{s60}$

Deformed Welded Wire Reinforcement Steel Area =  $A_{s70} = 60/70 \times A_{s60}$

When a reduced area of reinforcement is provided, any maximum bar spacing shown must also be reduced as determined by the following equations, unless otherwise shown:

Max. Grade 40 Bar Spacing = Grade 60 Bar Spacing

Max. Smooth Welded Wire Spacing = Grade 60 Bar Spacing x 0.86

Max. Deformed Welded Wire Spacing = Grade 60 Bar Spacing x 0.74

When an increased area of reinforcing is provided, the maximum bar spacing may be increased by the squared ration of increased steel area, but not to exceed 12":

Max. Bar Spacing Provided  $\leq$  Max. Bar Spacing Required  $\times \left( \frac{\text{Steel Area Provided}}{\text{Min. Steel Area Required}} \right)^2$

Use wire no smaller than than W3.1 or D4.0, or larger and with spacing 8" or less. Use bar reinforcement displaying the minimum yield designation grade mark, or either the number 60 or one (1) grade mark line to be acceptable at the higher value. Use maximum bar spacing no greater than two (2) times the slab thickness with a maximum spacing of 12" or three (3) times the wall thickness, with a maximum spacing of 18" for vertical bars and 12" for horizontal bars. Wires smaller than W3.1 or D4.0 may be used in the walls of ASTM C 478 round structure bottoms and round risers.

5. Fiber-reinforced concrete may be substituted for conventional steel reinforcement in accordance with the Structures Design Guidelines. Submit shop drawings corresponding to an approved fiber-reinforced concrete mix design for approval to the State Drainage Engineer.

**PRECAST OPTION AND EQUIVALENT REINFORCEMENT SUBSTITUTION**

LAST REVISION 11/01/20	REVISION	DESCRIPTION:	 <b>FY 2021-22 STANDARD PLANS</b>	<b>SUPPLEMENTARY DETAILS FOR DRAINAGE STRUCTURES</b>	INDEX <b>425-001</b>	SHEET <b>5 of 8</b>
---------------------------	----------	--------------	---	--	-------------------------	------------------------

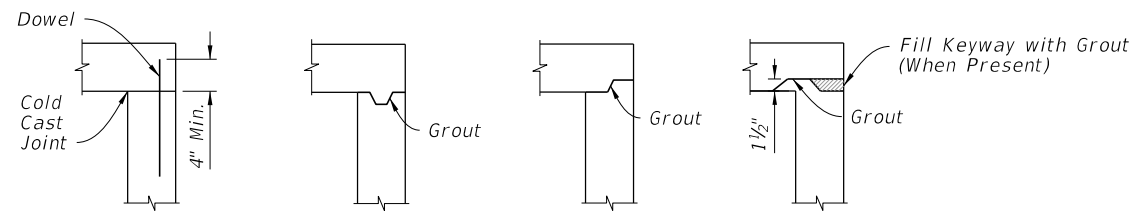

TOP SLABS TO WALL JOINTS

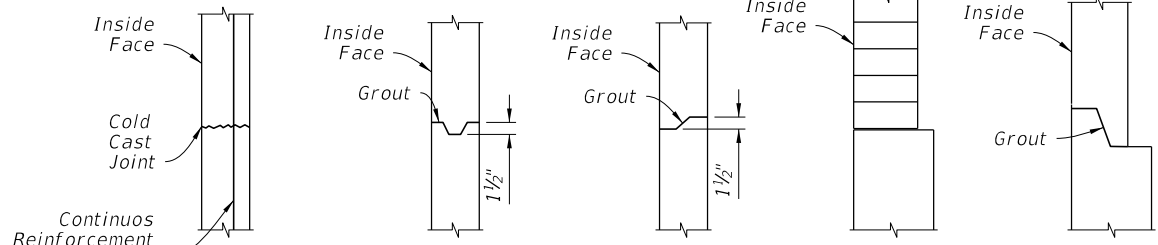

WALL JOINTS

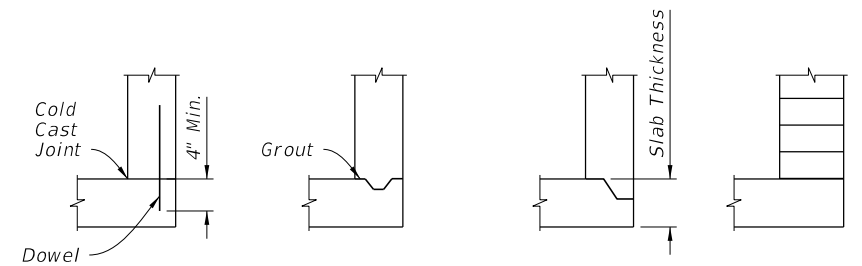

BOTTOM SLAB TO WALL JOINTS

**NOTES:**

1. One or more types of joints may be used in a single structure, except brick wall structure. Brick wall construction is permitted on circular units only.
2. All grouted joints are to have a maximum thickness of 1".
3. Keyways are to be a minimum of 1 1/2" deep.
4. Joint dowels are to be #4 bars, 12" long with a minimum of 6 bars per joint approximately evenly spaced for circular structures or at maximum 12" spacing for rectangular structures. Bars may be either Adhesive Bonded Dowels in accordance with Specification 416, or placed approximately 6" into fresh concrete leaving the remainder to extend into the secondary cast. Welded wire reinforcement may be substituted for the dowel bar in accordance with the equivalent steel area table on Sheet 5.
5. Minimum cover on dowel reinforcing bars is 2" to outside face of structure.
6. Seal joints between wall segments and between wall segments and top or bottom slabs with preformed plastic gasket material in accordance with Specification 430 or non-shrink grout in accordance with Specification 934.
7. Insert products approved by the Engineer may be used in lieu of dowel embedment.

CONSTRUCTION JOINT OPTIONS

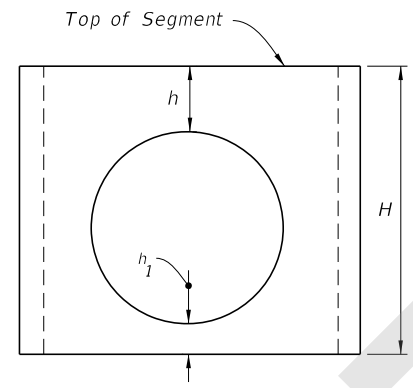

When  $6" \leq h_1 < 0.75H$  (Min.)  
 $h_1 \geq 0.75H$  (Min.)

Then (Reqd.)  
 $h \geq 0.4H$   
 $h \geq H$  (Min.)

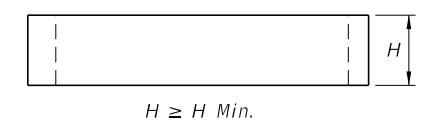
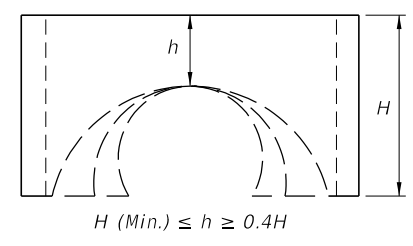

**TABLE 3**  
**Minimum Value for H**

H (min.)	Box or Riser Diameter
1'-0"	3'-6" & 4'-0"
1'-6"	5'-0" & 6'-0"
2'-0"	>6'-0"

**NOTES:**

1. Segments may be inverted. Opening for pipe is the pipe OD plus 6" ( $\pm 2"$  tolerance).
2. If  $h$  can not be attained, then a top or bottom slab must be attached to the segment as shown below.

RISER SEGMENTS OTHER THAN DOWEL

Riser or Inlet Opening (Location Varies)

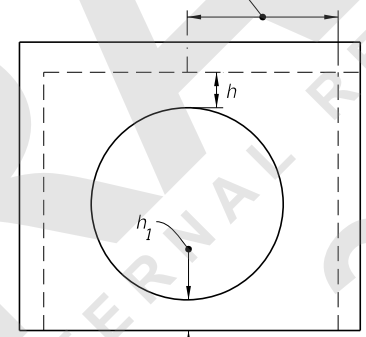

$h \geq \text{zero}$  and  $h_1 \geq 6"$

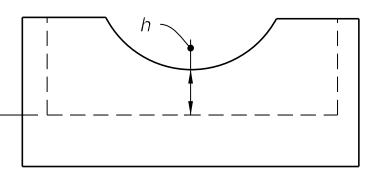

Top or Bottom Segment:  
 $h \geq 2"$

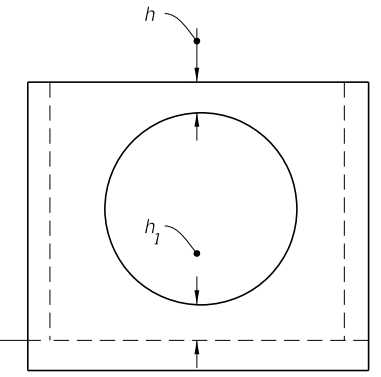

$h_1 \geq 2"$  and  $h \geq 6"$

**NOTES:**

1.  $h$  may be less than 6" when approved by the Engineer, but not for inlet segments at finish grade elevation.
2. Dowel construction joint or monolithic cast only.

SEGMENTS FOR SLAB TO WALL DOWEL CONSTRUCTION JOINTS OR MONOLITHIC CAST

MINIMUM BOX AND RISER SEGMENT DIMENSIONS

CONSTRUCTION JOINT OPTIONS AND MINIMUM BOX AND RISER SEGMENT DIMENSIONS

8/28/2020 1:30:30 PM

LAST REVISION 11/01/20	DESCRIPTION:		FY 2021-22 STANDARD PLANS	SUPPLEMENTARY DETAILS FOR DRAINAGE STRUCTURES	INDEX 425-001	SHEET 6 of 8
---------------------------	--------------	--	------------------------------	--	------------------	-----------------



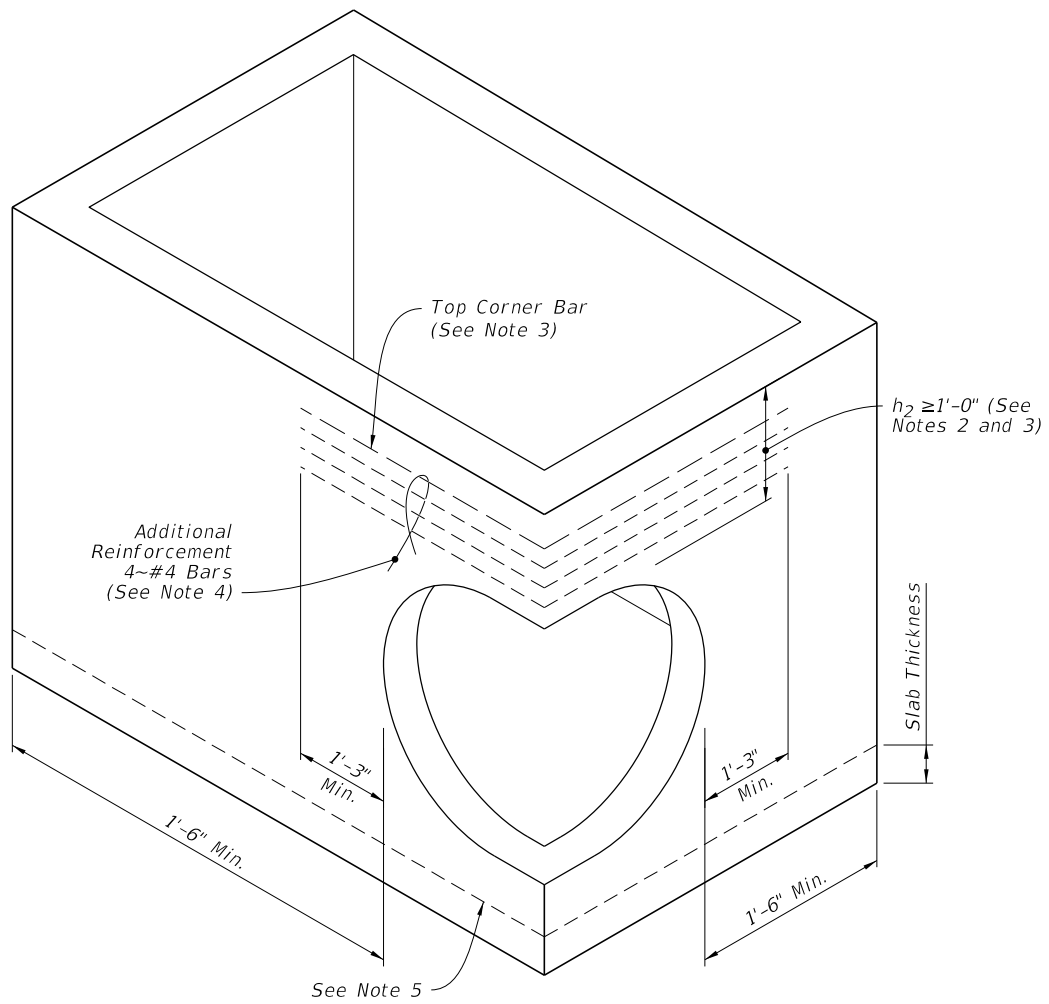

**NOTES:**

1. Submit Shop Drawings of corner openings for approval by the Engineer.
2.  $h_2$  may be less than 1'-0" when a minimum 1'-0" deep segment, 8" slab or curb inlet is provided above the corner opening.
3. For inlet segments at finish grade elevation, substitute a #8 Bar for the top corner bar when  $1'-0" \leq h_2 < 2'-0"$ .
4. Install bars continuously around corner and evenly spaced. Tie additional reinforcement to the outside of vertical wall reinforcement.
5. Dowel construction joint or monolithically cast wall and slabs.

PIPE OPENING AT CORNER

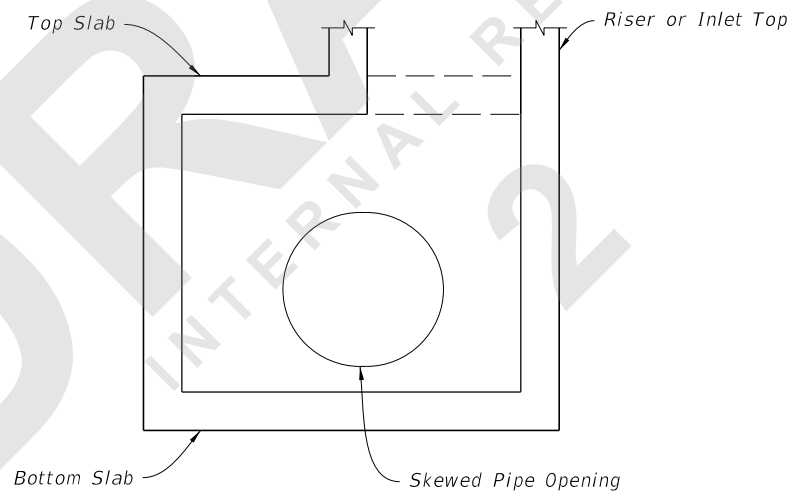
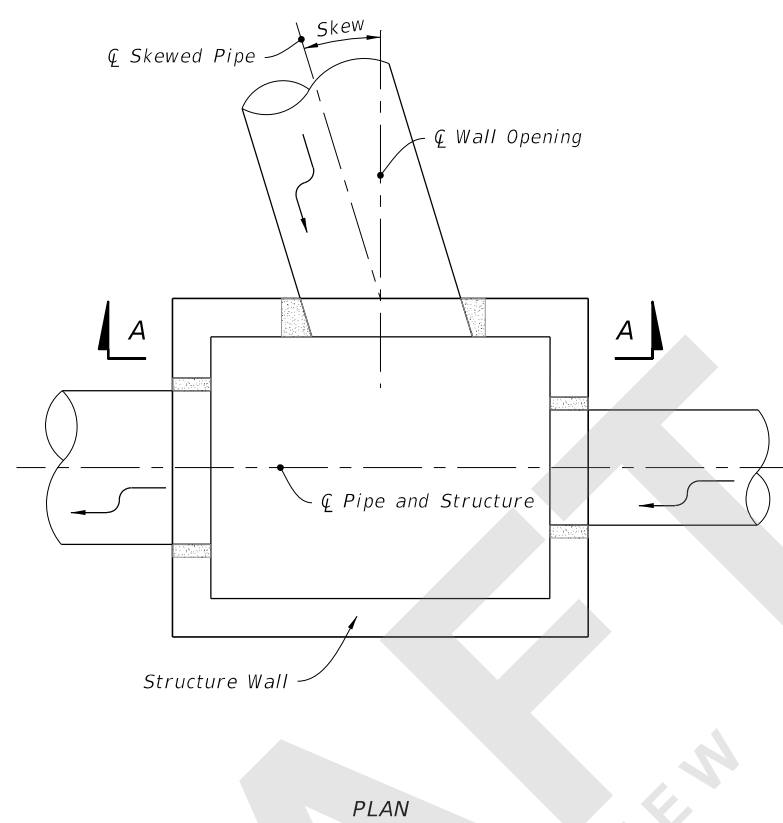

SKEWS  $\leq 45^\circ$   
(Not Centered)

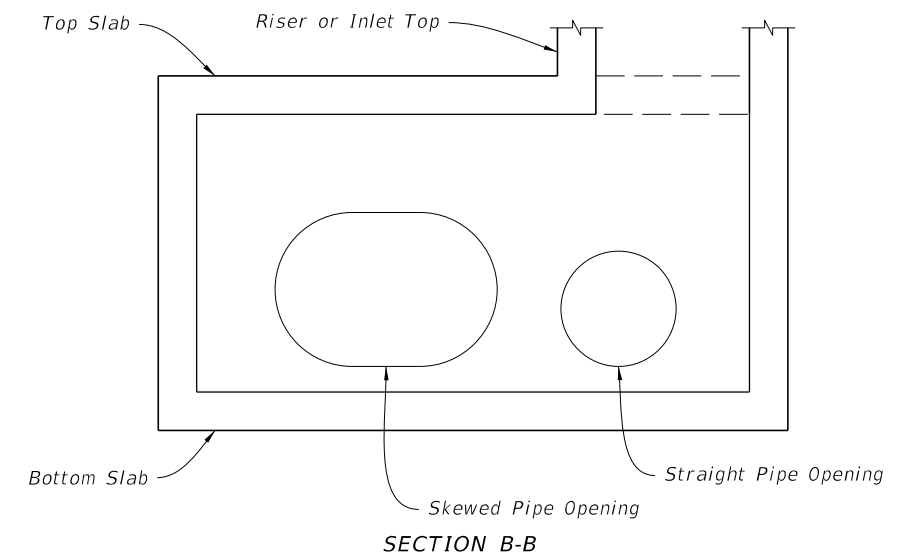
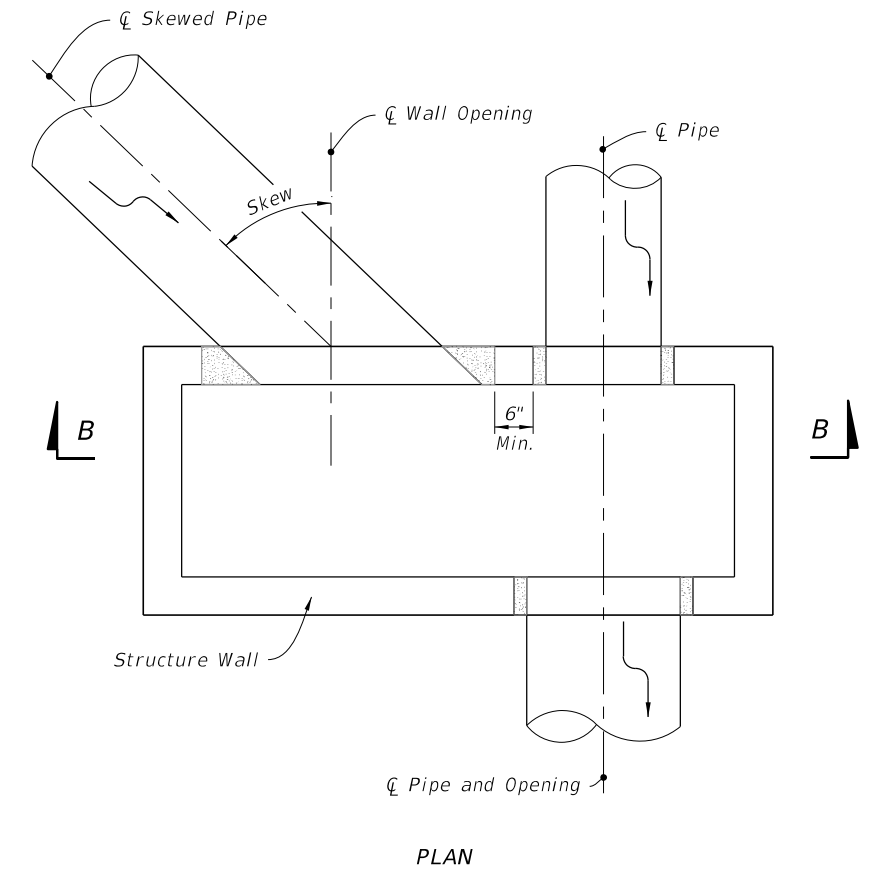

SKEWS  $> 45^\circ$   
(Not Centered)

SKewed PIPE IN RECTANGULAR STRUCTURES

SKewed PIPE IN RECTANGULAR STRUCTURES

8/28/2020 1:30:33 PM

LAST REVISION 11/01/20	DESCRIPTION:
---------------------------	--------------



FY 2021-22  
STANDARD PLANS

SUPPLEMENTARY DETAILS  
FOR DRAINAGE STRUCTURES

INDEX  
425-001

SHEET  
7 of 8

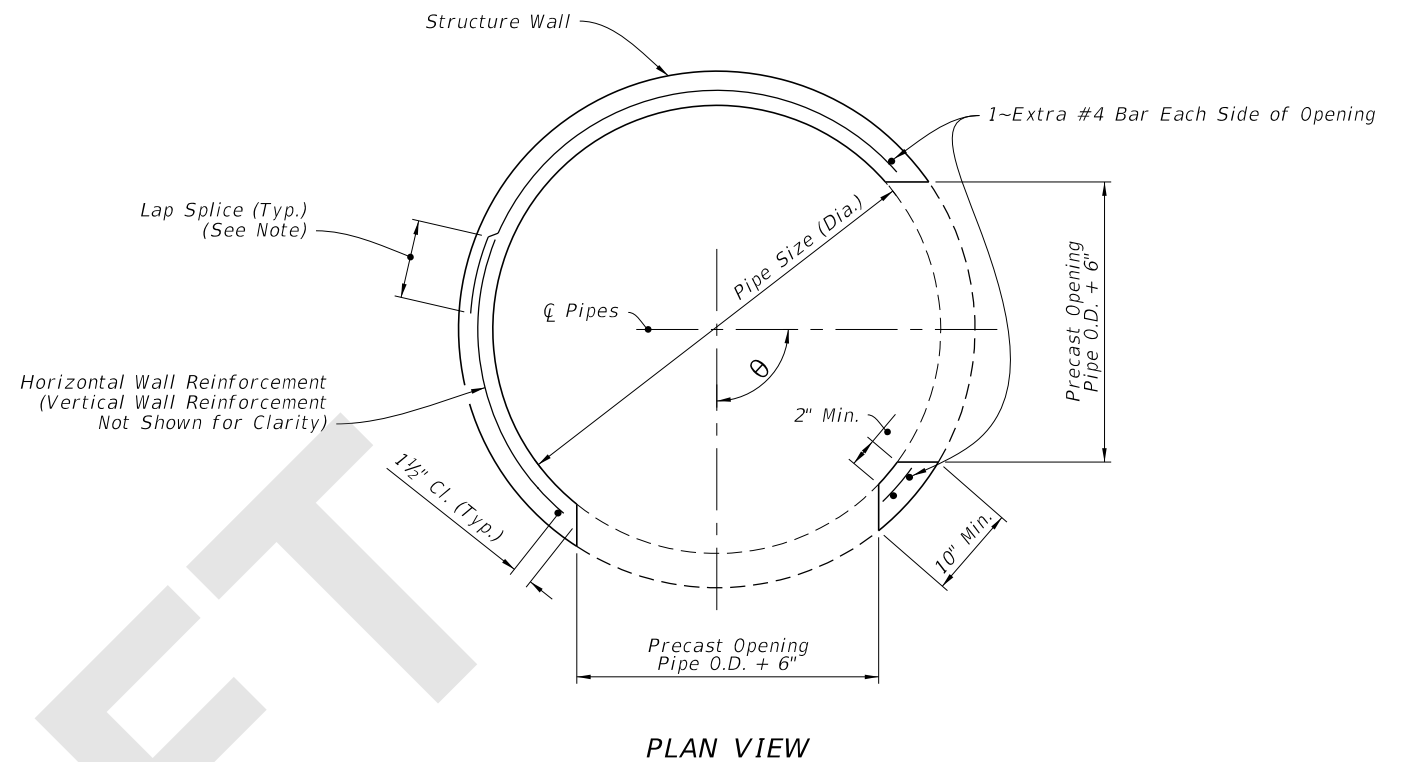
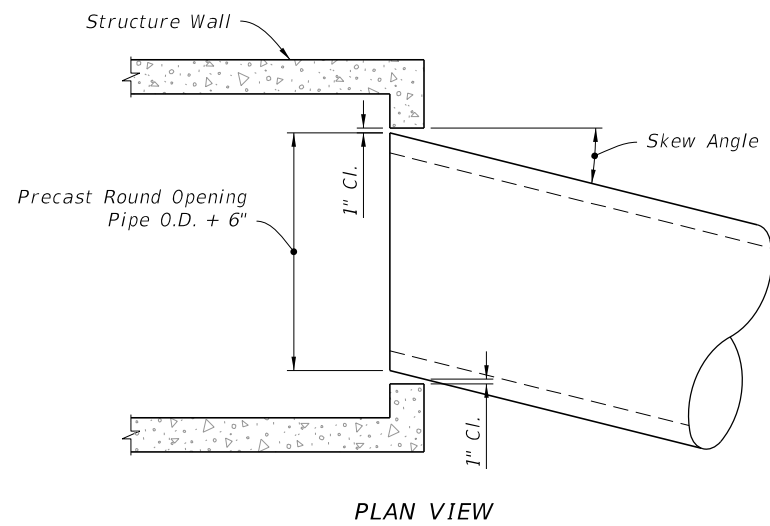

	WALL THICKNESS	PIPE SIZE													
		18"	24"	30"	36"	42"	48"	54"	60"	66"	72"	78"	84"		
MAXIMUM SKEW ANGLE	8"	19°	17°	16°	16°	15°	14°	14°	13°	13°	13°	12°	12°		
	6"	21°	20°	18°	17°	17°	16°	15°	15°	14°	14°	13°	13°		

**NOTE:**  
 These values are based on 2" clearance for precast structures. Larger skews are possible for Cast-In-Place Structures or elliptical pipe openings when approved by the Engineer.

**NOTE:**  
 Lap splice: 20 bar diameter for deformed wire or bar, but not less than vertical wire spacing plus 2" for WWR or 40 bar diameters for smooth wire.

MAXIMUM PIPE SKEW FOR PRECAST ROUND OPENINGS

MULTIPLE PIPE CONNECTIONS - PRECAST ROUND STRUCTURES

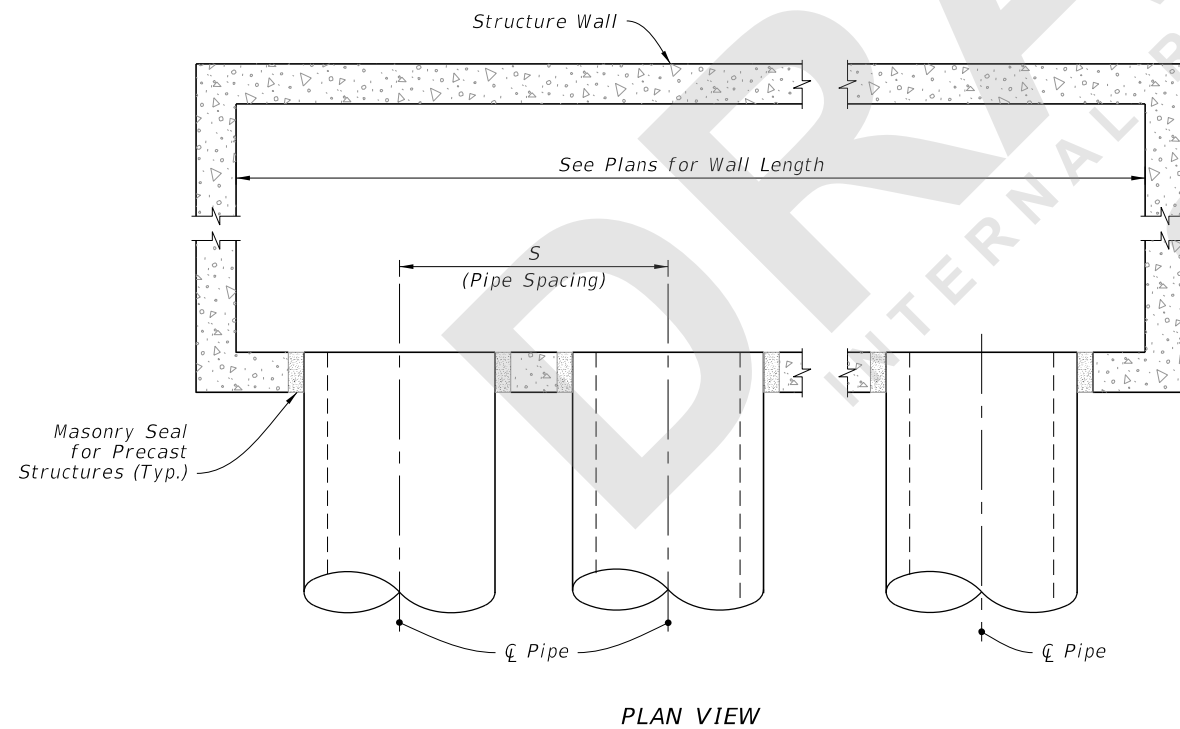

PIPE SIZE	PIPE SPACING (S)
18"	2'-10"
24"	3'-5"
30"	4'-3"
36"	5'-1"
42"	6'-0"
48"	6'-9"
54"	7'-8"
60"	8'-6"
66"	9'-0"
72"	10'-0"
78"	10'-9"
84"	11'-8"

MULTIPLE PARALLEL PIPE CONNECTIONS - RECTANGULAR STRUCTURES

MISCELLANEOUS PIPE CONNECTION DETAILS

8/28/2020 1:30:38 PM

LAST REVISION 11/01/20	DESCRIPTION:
---------------------------	--------------

 FY 2021-22  
 STANDARD PLANS

SUPPLEMENTARY DETAILS  
 FOR DRAINAGE STRUCTURES

INDEX 425-001	SHEET 8 of 8
------------------	-----------------