

# ORIGINATION FORM

Proposed Revisions to a Standard Plans Index  
(Please provide all information – Incomplete forms will be returned)

## Contact Information:

Date: March 25, 2019  
Originator: Cheryl Hudson  
Phone: (850) 414-5332  
Email: cheryl.hudson@dot.state.fl.us

## Standard Plans:

Index Number: 700-010  
Sheet Number (s): 6 and 7  
Index Title: Single Column Ground Signs

## Summary of the changes:

All Sheets: Renumbered.  
Sheet 6: Note 5: Clarify number of wind beams required.  
Sheet 7: New Sheet- Wind Beam Connection for Flip Up Sign.

## Commentary / Background:

From e-mail dated 1/24/19: confusion on signs between 12" and 66"

## Other Affected Offices / Documents: (Provide name of responsible personnel)

- | Yes                      | No                                  |                             |
|--------------------------|-------------------------------------|-----------------------------|
| <input type="checkbox"/> | <input checked="" type="checkbox"/> | Other Standard Plans –      |
| <input type="checkbox"/> | <input checked="" type="checkbox"/> | FDOT Design Manual –        |
| <input type="checkbox"/> | <input checked="" type="checkbox"/> | Basis of Estimates Manual – |
| <input type="checkbox"/> | <input checked="" type="checkbox"/> | Standard Specifications –   |
| <input type="checkbox"/> | <input checked="" type="checkbox"/> | Approved Product List –     |
| <input type="checkbox"/> | <input checked="" type="checkbox"/> | Construction –              |
| <input type="checkbox"/> | <input checked="" type="checkbox"/> | Maintenance –               |

## Origination Package Includes: (Email or hand deliver package to Derwood Sheppard)

- | Yes                      | N/A                                 |   |
|--------------------------|-------------------------------------|---|
| <input type="checkbox"/> | <input checked="" type="checkbox"/> | Redline Mark-ups                          |
| <input type="checkbox"/> | <input type="checkbox"/>            | Proposed Standard Plan Instructions (SPI) |
| <input type="checkbox"/> | <input type="checkbox"/>            | Revised SPI                               |
| <input type="checkbox"/> | <input type="checkbox"/>            | Other Support Documents                   |

## Implementation:

- Design Bulletin (Interim)    DCE Memo    Program Mgmt. Bulletin    FY-Standard Plans (Next Release)

Contact the Roadway Design Office for assistance in completing this form

**STEP 1:** Calculate the area and the centroid for an individual sign or a sign cluster. Note that the centroid and areas have been calculated for frequently used sign clusters. These are shown on Sheets 7, 8, and 9.

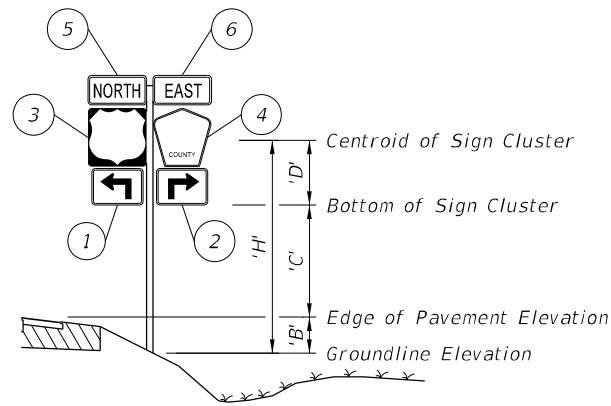

Size a x h	Centroid			'A <sub>n</sub> ' (in. <sup>2</sup> )	'X <sub>n</sub> ' x 'A <sub>n</sub> ' (in. <sup>3</sup> )	'Y <sub>n</sub> ' x 'A <sub>n</sub> ' (in. <sup>3</sup> )
	Local 'Y <sub>n</sub> ' (in.)	Global 'X <sub>n</sub> ' (in.)	Global 'Y <sub>n</sub> ' (in.)			
(1) 21 x 15	7.5	-10.5-1.5-1.5 = -13.5	7.5	315	-4,252.5	2,362.5
(2) 21 x 15	7.5	10.5+1.5+1.5 = 13.5	7.5	315	+4,252.5	2,362.5
(3) 24 x 24	12	-12-1.5 = -13.5	15+1+12 = 28	576	-7,776	16,128
(4) 24 x 24	12	12+1.5 = 13.5	15+1+12 = 28	436	5,886	12,208
(5) 24 x 12	6	-12-1.5 = -13.5	15+1+24+1+6 = 47	288	-3,888	13,536
(6) 24 x 12	6	12+1.5 = 13.5	15+1+24+1+6 = 47	288	3,888	13,536
<b>TOTALS</b>				<b>2,218</b>	<b>-1,890</b>	<b>60,133</b>

$$\Sigma ('A_n') = 2,218 \text{ in.}^2 = 15.4 \text{ ft.}^2 \quad \Sigma ('X_n' \times 'A_n') = -1,890 \text{ in.}^3 = -1.09 \text{ ft.}^3 \quad \Sigma ('Y_n' \times 'A_n') = 60,133 \text{ in.}^3 = 34.8 \text{ ft.}^3$$

$$'X_c' = \frac{\Sigma ('X_n' \times 'A_n')}{\Sigma 'A_n'} = -0.1 \text{ ft.} \quad 'Y_c' = \frac{\Sigma ('Y_n' \times 'A_n')}{\Sigma 'A_n'} = 2.26 \text{ ft.}$$

**STEP 2:** Determine the height 'H' from groundline to the centroid of the individual sign or sign cluster.

Assume: 'B' = 1 ft., 'C' = 7 ft.

Calculated: X<sub>c</sub> = -0.1 ft., Y<sub>c</sub> = 'D' 2.26 ft.

'H' = 'B' + 'C' + 'D' = 10.26 ft. ==> **USE 11 ft.**    Σ('A<sub>n</sub>') = 15.4 ft.<sup>2</sup> ==> **USE 16 ft.<sup>2</sup>**

**STEP 3:** Refer to the Aluminum Column (Post) Selection Tables and find the intersection point. See Sheet 3.

**ALUMINUM COLUMN (POST) SELECTION TABLE**

TOTAL PANEL AREA (SF)	'H' (FT)												
	8 ft	9 ft	10 ft	11 ft	12 ft	13 ft	14 ft	15 ft	16 ft	17 ft	18 ft	19 ft	20 ft
3 sf	2	2.5	2.5	2.5	3	3	3	3	3.5	3.5	3.5	3.5	3.5
4 sf	2.5	2.5	3	3	3	3	3.5	3.5	3.5	3.5	3.5	3.5	3.5
5 sf	2.5	3	3	3	3.5	3.5	3.5	3.5	3.5	3.5	3.5	3.5	4
6 sf	3	3	3.5	3.5	3.5	3.5	3.5	3.5	3.5	3.5	4	4	4
7 sf	3	3.5	3.5	3.5	3.5	3.5	3.5	3.5	4	4	4	4	4
8 sf	3.5	3.5	3.5	3.5	3.5	3.5	3.5	3.5	4	4	4	4	4
9 sf	3.5	3.5	3.5	3.5	3.5	3.5	4	4	4	4	4	4	4
10 sf	3.5	3.5	3.5	3.5	3.5	4	4	4	4	4	4	4.5	4.5
11 sf	3.5	3.5	3.5	3.5	4	4	4	4	4	4	4	4.5	4.5
12 sf	3.5	3.5	3.5	4	4	4	4	4	4	4	4	4.5	4.5
13 sf	3.5	3.5	4	4	4	4	4	4	4	4	4.5	4.5	4.5
14 sf	3.5	3.5	4	4	4	4	4	4	4.5	4.5	4.5	5	5
15 sf	3.5	4	4	4	4	4	4	4.5	4.5	4.5	5	5	5
16 sf	3.5	4	4	4	4	4	4	4.5	4.5	5	5	5	6
17 sf	4	4	4	4	4	4	4.5	4.5	4.5	5	5	6	6
18 sf	4	4	4	4	4	4.5	4.5	4.5	5	5	5	6	6
19 sf	4	4	4	4	4	4.5	4.5	4.5	5	5	6	6	6
20 sf	4	4	4	4	4.5	4.5	4.5	5	5	5	6	6	6
21 sf	4	4	4	4	4.5	4.5	5	5	5	6	6	6	6
22 sf	4	4	4	4.5	4.5	4.5	5	5	6	6	6	6	6
23 sf	4	4	4	4.5	4.5	5	5	5	6	6	6	6	6
24 sf	4	4	4.5	4.5	4.5	5	5	6	6	6	6	6	6
25 sf	4	4	4.5	4.5	5	5	5	6	6	6	6	6	8
26 sf	4	4.5	4.5	4.5	5	5	5	6	6	6	6	8	8
27 sf	4	4.5	4.5	4.5	5	5	6	6	6	6	6	8	8
28 sf	4	4.5	4.5	5	5	5	6	6	6	6	6	8	8
29 sf	4.5	4.5	4.5	5	5	6	6	6	6	6	8	8	8
30 sf	4.5	4.5	5	5	5	6	6	6	6	6	8	8	8

For 'H' = 11 ft., Area = 16 ft.<sup>2</sup>

- Refer to the Aluminum Column (Post) Selection Table, from Sheet 3 and shown here for reference.

- To determine the required post size, find the intersection of the row labeled "16 SF" and the column labeled "11 FT". For the example the intersection value is "4" (4" OD).

- In the Column (Post) and Foundation Table, the value "4" shows the design requires a 4.0" diameter and 1/4" thick Aluminum Column (Post) and a 2.0' diameter and 3.5' deep Concrete Foundation and 3.0' Stub.

**STEP 4:** For sign assemblies with signs oriented in two directions, only the sign with the largest area should be analyzed to determine the Column (Post) requirements.

SHEET	CONTENTS
1	General Notes and Design Example
2	Design Example - Centroid
3	Column and Foundation Tables
4	Slip Base and Foundation Details
5	Driven Post and Soil Plate Detail
6	Wind Beam Connection
7, 8 & 9	Frequently Used Sign Clusters

**GENERAL NOTES:**

- Shop Drawings: This Index is considered fully detailed. Submit Shop Drawings only for minor modifications not detailed in the Plans.
- Aluminum Sign, Wind Beams and Column (Post) Materials:
  - Aluminum Plates: ASTM B209, Alloy 6061-T6
  - Aluminum Bars and Extruded Shapes: ASTM B221, Alloy 6061-T6
  - Aluminum Structural Shapes: ASTM B308 Alloy 6061-T6
  - Cast Aluminum: ASTM B26 Alloy A356-T6
  - Aluminum Weld Material: ER 5556 or 5356
- Sign Mounting Bolts, Nuts and Washers:
  - Aluminum Button Head and Flat Head Bolts: ASTM F468 Alloy 2024-T4
  - Aluminum Hex Nuts: ASTM F467 Alloy 6061-T6 or 6262-T9
  - Aluminum Washers: ASTM B221, Alloy 7075-T6
- Stainless Steel Bolts, Nuts and Washers may be used in lieu of the Aluminum button head and flat head bolts as follows:
  - Stainless Steel Bolts: ASTM F 593 Alloy Group 2, Condition A, CW1 or SH1
  - Stainless Steel Nuts: ASTM F594
- Sign Column (Post) Bolts, Nuts and Washers:
  - Galvanized U-Bolt (Column): ASTM A449 or ASTM A193 B7 according to ASTM F2329 with double nuts.
  - Aluminum Bolts (Sleeve): ASTM F468, Alloy 6061-T6 or 2024-T4 with Hex Nuts F467 6061-T6 or 6262-T9 and Washers B221, Alclad 2024-T4
  - Galvanized High Strength Hex Head Bolts (Base Bolts): ASTM F3125, Grade A325, Type 1
  - Galvanized Hex Nuts: ASTM A563 Grade DH
  - Galvanized Washers: ASTM F436
  - Galvanized Bolts (Sleeve): ASTM A307 with Galvanized Hex Nuts and Washers
- Coatings:
  - Aluminum Fasteners: Anodic coating (0.0002 inches min.) and chromate sealed
  - High Strength Steel Bolts Nuts and Washers: ASTM F2329
  - All other steel items (excluding stainless steel): Hot-dip Galvanize - ASTM A123
  - Repair damaged galvanizing in accordance with Specification 562
- BREAKAWAY SUPPORTS REQUIREMENTS: Install non-frangible aluminum column (post) (larger than 3 1/2") with breakaway supports as shown on Sheet 4. Signs shielded by barrier wall or guardrail do not require breakaway support.

GUIDE TO USE THIS INDEX

Renumbered: 1 of 10

GENERAL NOTES AND DESIGN EXAMPLE

10/18/2018 12:41:11 PM

LAST REVISION <b>11/01/18</b>	DESCRIPTION: <b>11/01/19</b>	FDOT FY 2019-20 STANDARD PLANS	SINGLE COLUMN GROUND SIGNS	INDEX <b>700-010</b>	SHEET <b>1 of 9</b>
----------------------------------	---------------------------------	--------------------------------------	----------------------------	-------------------------	------------------------

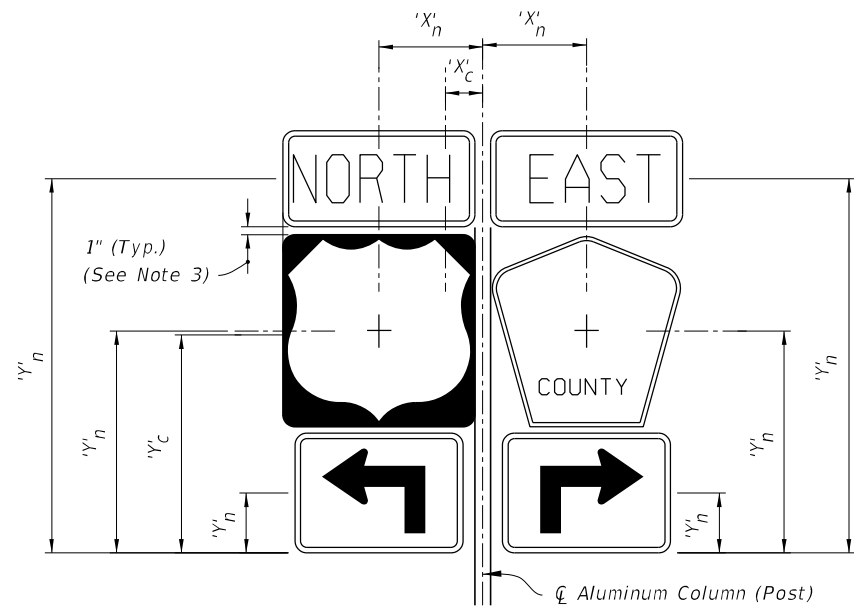

SIGN CLUSTER

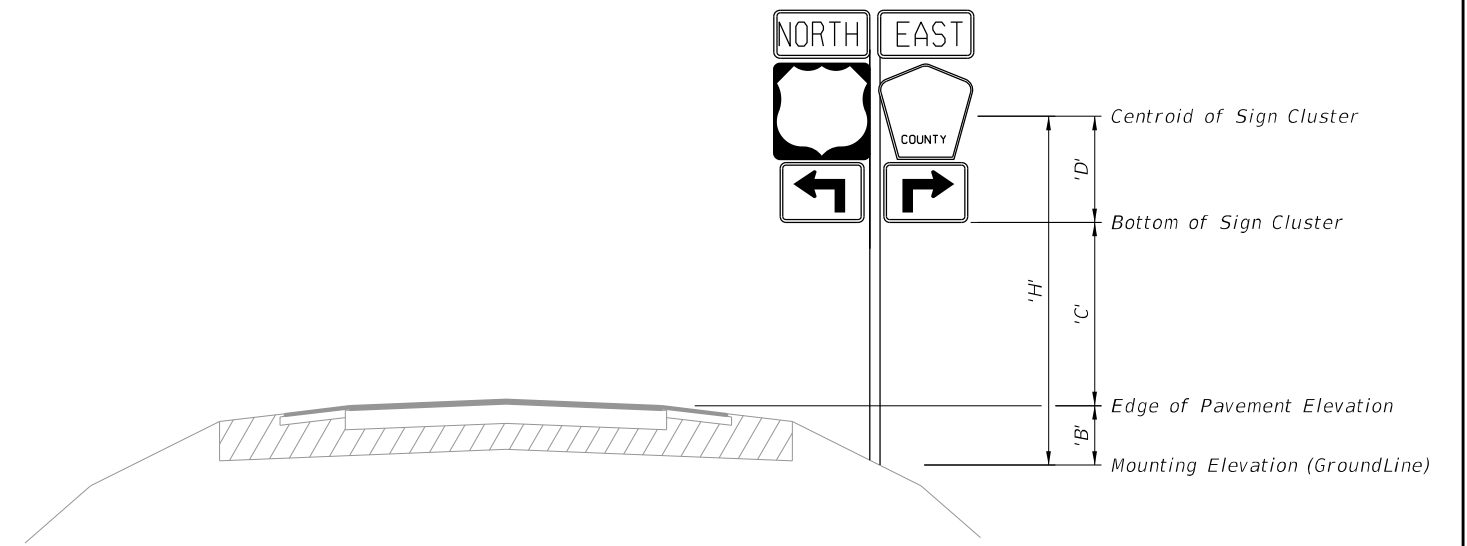

TYPICAL SECTION

$$X'_c = \frac{\sum (X'_n \times A'_n)}{\sum A'_n} \quad Y'_c = \frac{\sum (Y'_n \times A'_n)}{\sum A'_n}$$

- 'A'<sub>n</sub> = Area of individual sign
- 'B' = Height of the edge of pavement from the mounting elevation
- 'C' = Height of the the bottom of the sign or cluster from the edge of pavement elevation
- 'D' = Height of the centroid of the sign or cluster from the bottom of the sign or cluster
- h = Individual sign height
- 'H' = Height of sign or cluster centroid from groundline
- a = Individual sign width
- 'X'<sub>c</sub> = Centroid horizontal location of sign or cluster from  $\phi$  Aluminum Column (Post)
- 'Y'<sub>c</sub> = Centroid height of sign or cluster from bottom of sign cluster
- 'X'<sub>n</sub> = Individual sign centroid horizontal location from  $\phi$  Aluminum Column (Post)
- 'Y'<sub>n</sub> = Individual Sign centroid height from bottom of sign cluster

NOTES:

1. For 'B' & 'C' see Index 700-101 and Roadway Plans.
2. Do not exceed an area of 30 SF or a width of 60 inches for a sign or a sign cluster, including rotated sign panels.
3. Vertical sign spacing (1" shown on Sign Cluster detail) also applies to rotated signs.

CALCULATION OF SIGN CLUSTER CENTROID

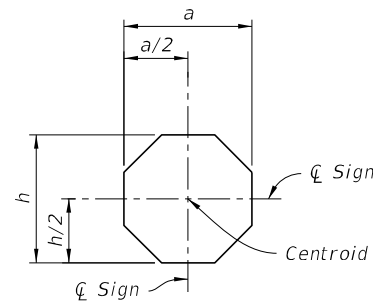

STOP

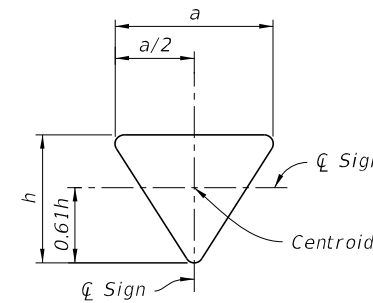

YIELD

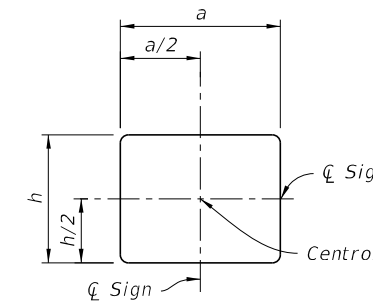

RECTANGLE

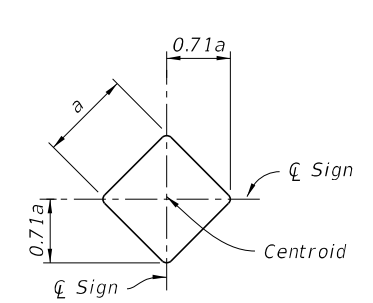

DIAMOND

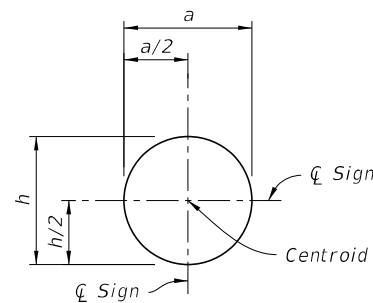

RAILROAD

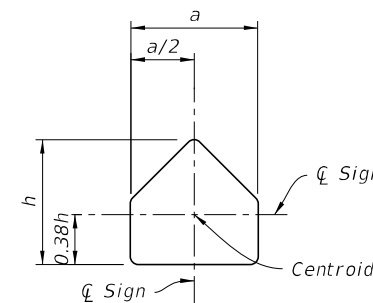

SCHOOL

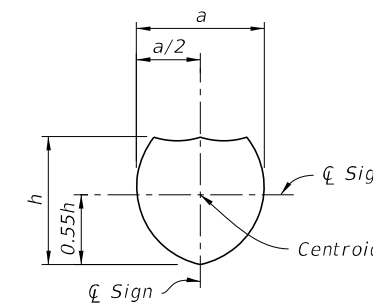

SHIELD

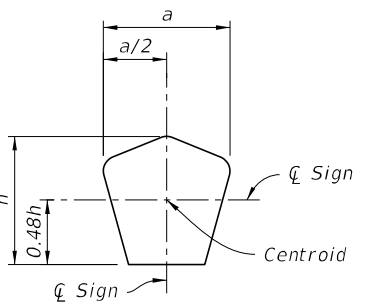

COUNTY

Renumbered: 2 of 10

DESIGN EXAMPLE - CENTROID

10/18/2018 12:41:14 PM

LAST REVISION	DESCRIPTION:
11/01/18	11/01/19



FY 2019-20  
STANDARD PLANS

SINGLE COLUMN GROUND SIGNS

INDEX	SHEET
700-010	2 of 9

		ALUMINUM COLUMN (POST) SELECTION TABLE (O.D. in.)												
		'H' (FT)												
		8 ft	9 ft	10 ft	11 ft	12 ft	13 ft	14 ft	15 ft	16 ft	17 ft	18 ft	19 ft	20 ft
TOTAL PANEL AREA (SF)	3 sf	2	2.5	2.5	2.5	3	3	3	3	3.5	3.5	3.5	3.5	3.5
	4 sf	2.5	2.5	3	3	3	3	3.5	3.5	3.5	3.5	3.5	3.5	3.5
	5 sf	2.5	3	3	3	3.5	3.5	3.5	3.5	3.5	3.5	3.5	4	4
	6 sf	3	3	3.5	3.5	3.5	3.5	3.5	3.5	3.5	3.5	4	4	4
	7 sf	3	3.5	3.5	3.5	3.5	3.5	3.5	3.5	4	4	4	4	4
	8 sf	3.5	3.5	3.5	3.5	3.5	3.5	3.5	4	4	4	4	4	4
	9 sf	3.5	3.5	3.5	3.5	3.5	3.5	4	4	4	4	4	4	4
	10 sf	3.5	3.5	3.5	3.5	3.5	4	4	4	4	4	4	4.5	4.5
	11 sf	3.5	3.5	3.5	3.5	4	4	4	4	4	4	4.5	4.5	4.5
	12 sf	3.5	3.5	3.5	4	4	4	4	4	4	4	4.5	4.5	4.5
	13 sf	3.5	3.5	4	4	4	4	4	4	4	4.5	4.5	4.5	5
	14 sf	3.5	3.5	4	4	4	4	4	4	4	4.5	4.5	4.5	5
	15 sf	3.5	4	4	4	4	4	4	4	4.5	4.5	4.5	5	5
	16 sf	3.5	4	4	4	4	4	4	4	4.5	4.5	5	5	5
	17 sf	4	4	4	4	4	4	4	4.5	4.5	4.5	5	5	6
	18 sf	4	4	4	4	4	4	4.5	4.5	4.5	5	5	5	6
	19 sf	4	4	4	4	4	4	4.5	4.5	4.5	5	5	6	6
	20 sf	4	4	4	4	4.5	4.5	4.5	5	5	5	6	6	6
	21 sf	4	4	4	4	4.5	4.5	5	5	5	6	6	6	6
	22 sf	4	4	4	4.5	4.5	4.5	5	5	6	6	6	6	6
	23 sf	4	4	4	4.5	4.5	5	5	5	6	6	6	6	6
	24 sf	4	4	4.5	4.5	4.5	5	5	6	6	6	6	6	6
	25 sf	4	4	4.5	4.5	5	5	5	6	6	6	6	6	8
	26 sf	4	4.5	4.5	4.5	5	5	5	6	6	6	6	6	8
	27 sf	4	4.5	4.5	4.5	5	5	6	6	6	6	6	6	8
	28 sf	4	4.5	4.5	5	5	5	6	6	6	6	6	6	8
	29 sf	4.5	4.5	4.5	5	5	6	6	6	6	6	6	8	8
	30 sf	4.5	4.5	5	5	5	6	6	6	6	6	6	8	8

FOUNDATION TABLE						
Column (Post) Size		Foundation Alternatives				
		Driven Post *		Concrete (Class I)		
Outside Diameter (in)	Wall Thk. (in)	Embedment Depth (ft)		Diameter (ft)	Embedment Depth (ft)	Stub Length (ft)
		without Soil Plate	with Soil Plate			
2.0	1/8	4.5	2.5	---	---	---
2.5	1/8	5.0	3.0	---	---	---
3.0	1/8	5.0	3.5	---	---	---
3.5	3/16	6.0	4.5	---	---	---
4.0	1/4	---	---	2.0	3.5	3.0
4.5	1/4	---	---	2.0	4.0	3.0
5.0	1/4	---	---	2.0	4.5	3.0
6.0	1/4	---	---	2.0	5.0	3.0
8.0	1/4	---	---	2.0	5.5	3.0

**\* INSTALLING FRANGIBLE COLUMN SUPPORTS:**

Columns (posts) 3 1/2" O.D. and less are considered frangible and may be installed either by driving the post or setting the posts in preformed holes. Backfill preformed holes with suitable material tamped in layers not thicker than 6" (to provide adequate compaction) or filled with flowable fill or bagged concrete.

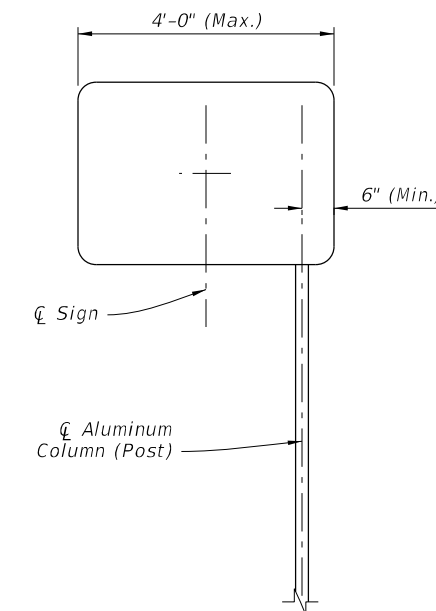

OFFSET SIGN

**NOTE:**

1. For offset sign placement see Index 700-101.
2. For signs with widths greater than 4' see Index 700-011.
3. Offset signs with driven posts require a soil plate.

Renumbered: 3 of 10

COLUMN AND FOUNDATION TABLES

10/18/2018 12:41:15 PM

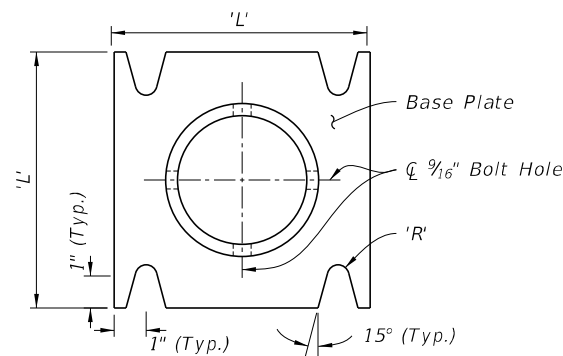
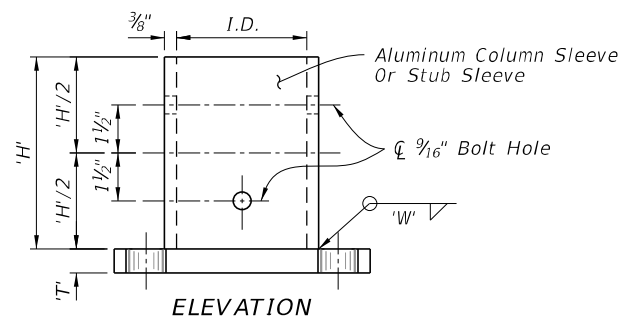

**STUB/SLEEVE & BASE PLATE DETAILS**  
(Welded Or Sandcast)

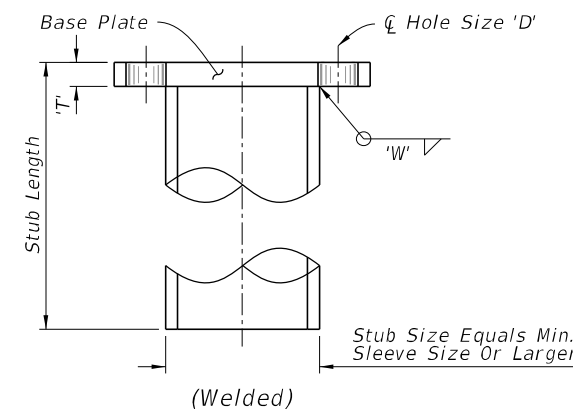

**STUB DETAIL**

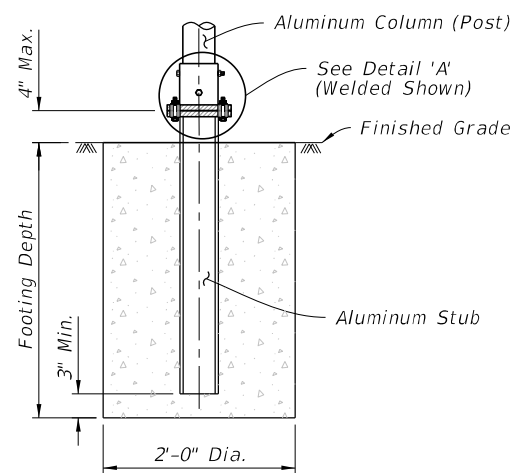

**SLIP BASE AND FOUNDATION DETAIL**  
(Non-Frangible Column, Typ.)

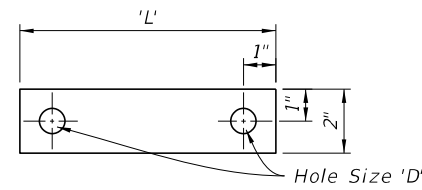

28 Ga. Thick Aluminum Strip  
2 Req'd. Per Base

**BOLT KEEPER PLATE DETAIL**

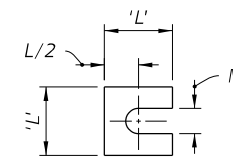

Provide 2-0.0149" Thick (28 gauge)  
and 2-0.0329" Thick (21 gauge)  
Brass Shims Per Post

**SHIM DETAIL**

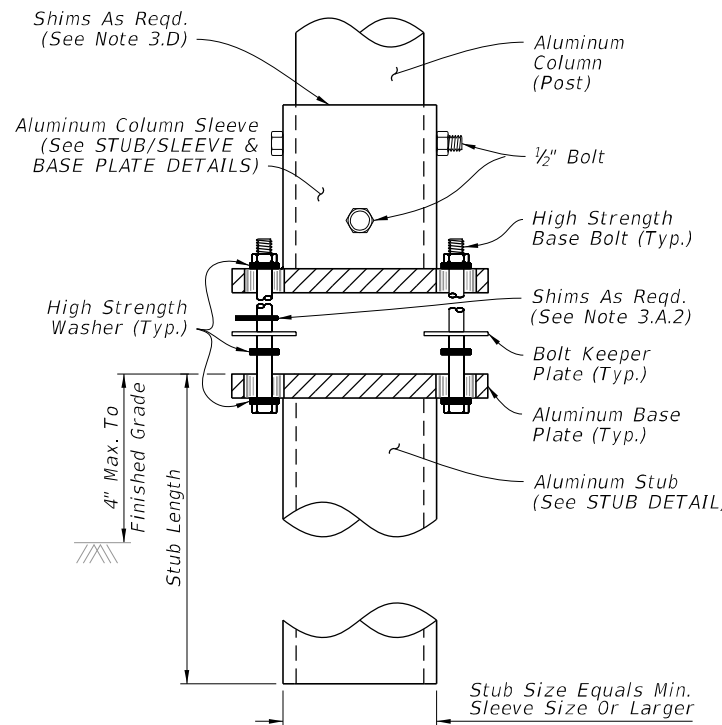

**WELDED STUB BASE**

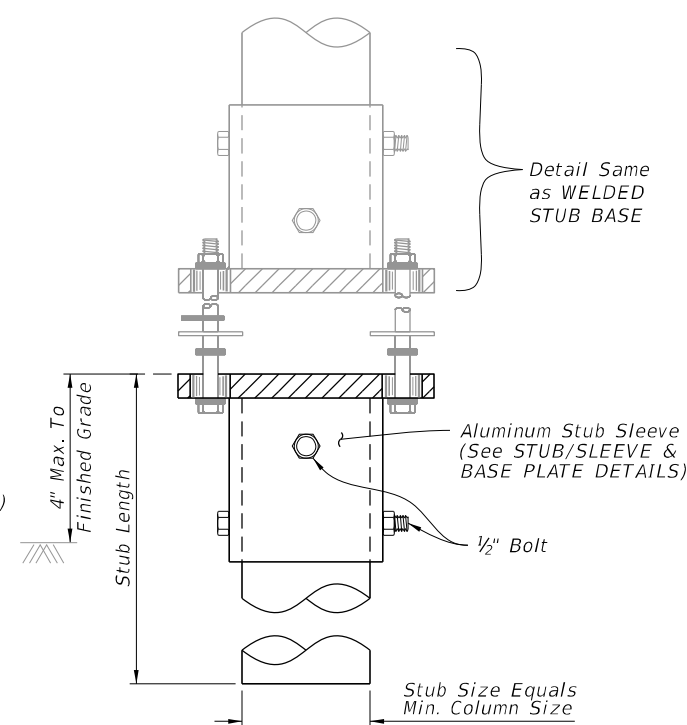

**BOLTED STUB/SLEEVE BASE**

**DETAIL 'A'**

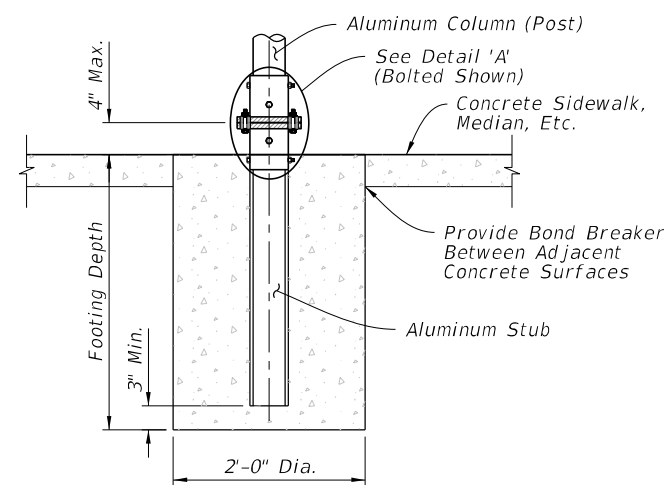

**SLIP BASE AND FOUNDATION DETAIL IN CONCRETE**  
(Non-Frangible Column In Crossovers, Medians & Sidewalks)

**NOTES:**

**1. Foundation Notes for Slip Base:**

A. Place Stub into concrete foundation given in the FOUNDATION TABLE using Class 1 Concrete.

**2. Slip Base Fabrication Notes:**

- A. The difference between the O.D. of the post and I.D. of the Sleeve must be 1/16" or less.
- B. Either a Welded Stub Base or Bolted Stub/Sleeve Base may be used in Slip Base.
- C. For cast base plates bolted to foundation stubs, use a foundation stub the same size as the sign column (Post).

**3. Slip-Base Assembly Instructions:**

- A. Assemble the Slip Base as follows:
  1. Insert Post into Sleeve and connect using 2 - 1/2" diameter Sleeve Bolts.
  2. Assemble top base plate to bottom Base Plate using Base Bolts (High strength) with 3 washers per bolt. (See Detail 'A'):
    - a. Place one washer on each Base Bolt between the bottom Base Plate and the Base Bolt head.
    - b. Place the next washer between the Bottom Base Plate and the Bolt Keeper Plate.
    - c. Use brass or galvanized steel shims to plumb the post.
    - d. Add the top base plate section.
    - e. Place the third washer between the Top Base Plate and the Nut.
- B. Orient the Bolt Keeper Plates in the Direction of Traffic.
- C. Tighten Base Bolts as follows:
  1. Tighten Base Bolts to the maximum possible with a 12" to 15" wrench (this will bed the washers and shims and clear the bolt threads).
  2. Loosen each Base Bolt one turn.
  3. Under the supervision of the Engineer, use a calibrated wrench to tighten bolts to the torque prescribed in the SLIP BASE DETAILS Table. Over tightened Base Bolts are not permitted.
  4. Distort bolt threads at the junction with nuts to prevent loosening. Repair damaged galvanizing.
- D. Obtain a tight sleeve connection by placing 4 galvanized steel shims between the column (post) and sleeve. Space the shims evenly around the perimeter of the column (1 between each bolt hole, 4 total). Use shims that are 1" shorter than the height of the sleeve.

Column (Post) Size		SLIP BASE DETAILS												
Outside Dia.	Wall Thickness	Sleeve I.D. (Max.)	Sleeve Height 'H'	Weld 'W'	Base Plate		Radius 'R'	Base Bolt		Base Plate Torque		Hole Size 'D'	SHIM	
					'L'	'T'		Size	Length	ft-lbs	in.-lbs		L	M
4"	1/4"	4 1/16"	6"	1/4"	8"	3/4"	1 1/32"	5/8"	3"	29	345	1 1/16"	1 3/8"	1 1/16"
4 1/2"	1/4"	4 9/16"	6"	1/4"	8"	7/8"	1 1/32"	5/8"	3 1/4"	29	345	1 1/16"	1 3/8"	1 1/16"
5"	1/4"	5 1/16"	7"	1/4"	8"	7/8"	1 1/32"	5/8"	3 1/4"	29	345	1 1/16"	1 3/8"	1 1/16"
6"	1/4"	6 1/16"	8"	1/4"	9"	1"	1 3/32"	3/4"	3 1/2"	46	554	1 3/16"	1 3/4"	1 3/16"
8"	1/4"	8 1/16"	10"	1/4"	11"	1"	1 5/32"	7/8"	3 3/4"	53	640	1 5/16"	2 3/8"	1 1/16"

Renumbered: 4 of 10

**SLIP BASE AND FOUNDATION DETAILS**

10/18/2018 12:41:17 PM

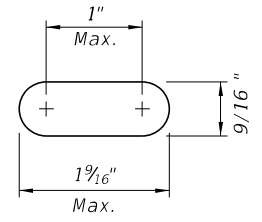

Optional Slotted Holes

DETAIL "B"

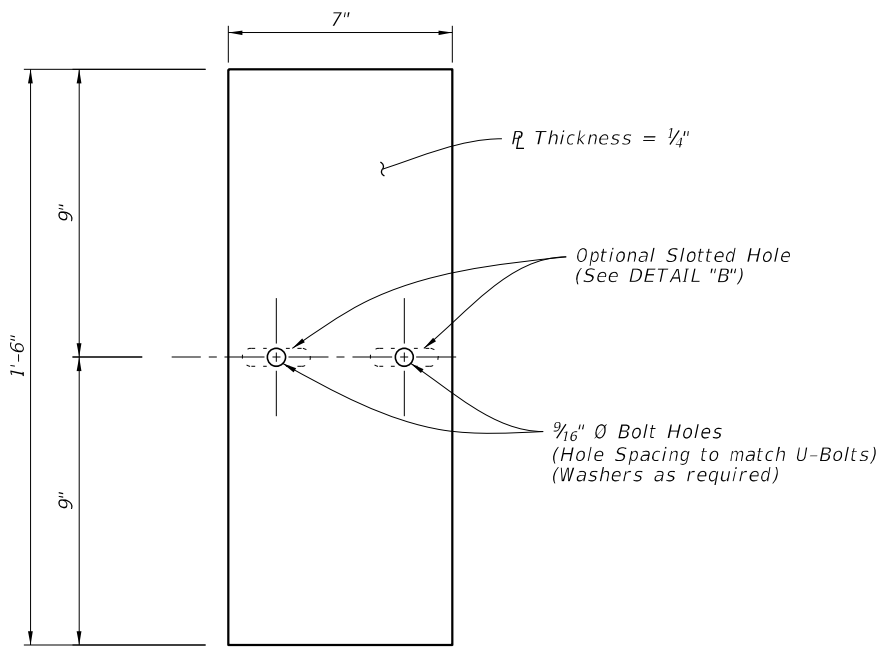

ALUMINUM SOIL PLATE DETAIL

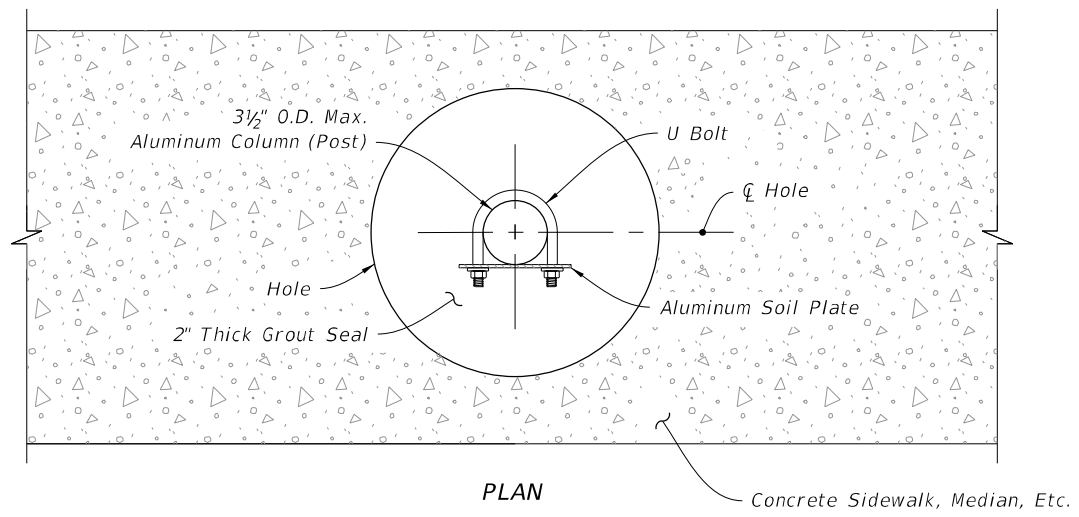

PLAN

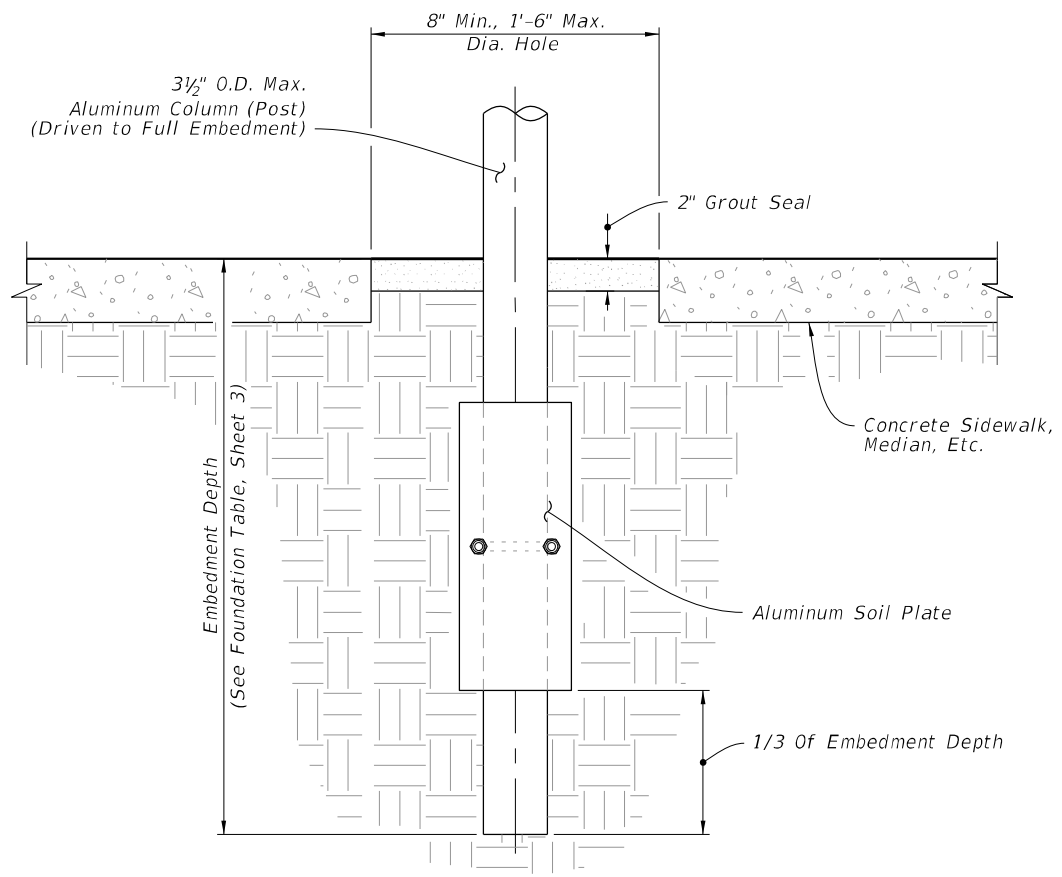

ELEVATION

DRIVEN POST DETAIL

(Frangible Post In Crossovers, Medians & Sidewalks)

Renumbered: 5 of 10

DRIVEN POST AND SOIL PLATE DETAIL

10/18/2018 12:41:18 PM

LAST REVISION	DESCRIPTION:		FY 2019-20 STANDARD PLANS	SINGLE COLUMN GROUND SIGNS	INDEX	SHEET
11/01/18	11/01/19				700-010	5 of 9

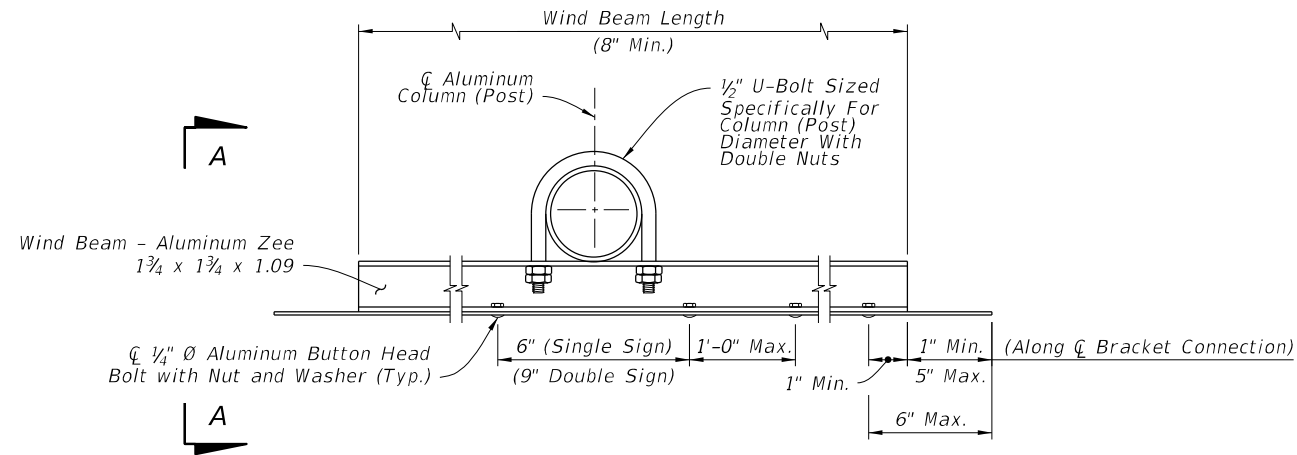

WIND BEAM CONNECTIONS DETAILS

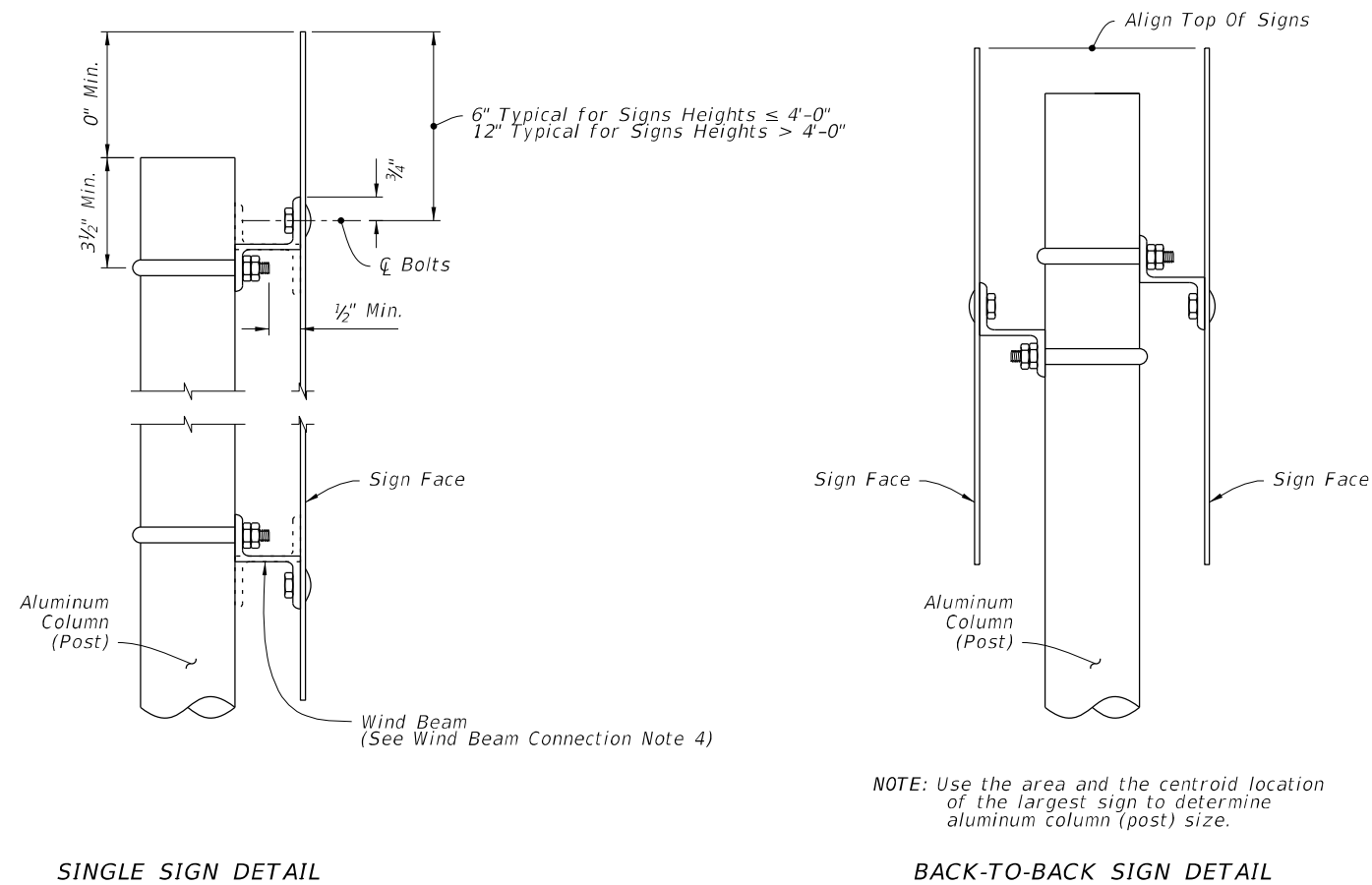

NOTES:

1.  $\frac{5}{16}$ "  $\emptyset$  Stainless Steel Hex Head Bolts with Flat Washer under Head and Washer under Nut may be used in lieu of  $\frac{1}{4}$ "  $\emptyset$  Aluminum Button or Flat Head Bolts.
2. Use Nylon washers (provided by the sheeting supplier) under the button bolt heads to protect sign sheeting.
3. Slots up to 2" long are allowed in wind beams to accommodate U-Bolts for varying Column (Post) diameters.
4. Wind beams may be oriented in either direction.
5. For ~~rectangular~~ signs greater than 66" <sup>in height</sup> install a third wind beam evenly spaced between the top and bottom wind beams. For ~~rectangular~~ signs up to 12" in height, use only one wind beam at  $\emptyset$  Sign.

Install two wind beams on signs with heights greater than 12" and less than or equal to 66".

Renumbered: 6 of 10

WIND BEAM CONNECTION

10/18/2018 12:41:19 PM















VIEW A-A



















LAST REVISION 11/01/18	DESCRIPTION: 11/01/19	FDOT FY 2019-20 STANDARD PLANS	SINGLE COLUMN GROUND SIGNS	INDEX 700-010	SHEET 6 of 9
---------------------------	--------------------------	--------------------------------------	----------------------------	------------------	-----------------

























NEW SHEET 7

WIND BEAM CONNECTION FOR FLIP UP SIGN



	Size	Area	Total Area	Centroid
 	36x12	3.00 SF	6.31 SF	1.75 Ft.
	24x24	3.31 SF		
 	36x12	3.00 SF	8.18 SF	1.92 Ft.
	30x30	5.18 SF		
 	36x12	3.00 SF	10.46 SF	2.10 Ft.
	36x36	7.46 SF		
 	36x12	3.00 SF	16.25 SF	2.48 Ft.
	48x48	13.25 SF		
 	24x24	3.31 SF	6.31 SF	1.71 Ft.
	24x18	3.00 SF		
 	30x30	5.18 SF	10.18 SF	2.19 Ft.
	30x24	5.00 SF		
 	36x36	7.46 SF	12.46 SF	2.55 Ft.
	30x24	5.00 SF		

	Size	Area	Total Area	Centroid
 	36x12	3.00 SF	13.18 SF	2.87 Ft.
	30x30	5.18 SF		
	30x24	5.00 SF	15.46 SF	3.15 Ft.
	36x36	7.46 SF		
 	36x12	3.00 SF	15.46 SF	3.15 Ft.
	36x36	7.46 SF		
	30x24	5.00 SF	15.46 SF	3.15 Ft.
	36x36	7.46 SF		
 	21x15	2.19 SF	6.19 SF	1.60 Ft.
	24x24	4.00 SF		
 	21x15	2.19 SF	7.19 SF	1.52 Ft.
	30x24	5.00 SF		
  	24x12	2.00 SF	6.00 SF	1.53 Ft.
	24x24	4.00 SF		
  	24x12	2.00 SF	7.00 SF	1.45 Ft.
	30x24	5.00 SF		
  	30x15	3.13 SF	8.13 SF	1.66 Ft.
	30x24	5.00 SF		

	Size	Area	Total Area	Centroid
 	24x24	4.00 SF	6.19 SF	1.73 Ft.
	21x15	2.19 SF		
 	30x24	5.00 SF	7.19 SF	1.81 Ft.
	21x15	2.19 SF		
    	24x12	2.00 SF	8.19 SF	2.26 Ft.
	24x24	4.00 SF		
    	24x12	2.00 SF	9.19 SF	2.27 Ft.
	30x24	5.00 SF		
    	30x15	3.13 SF	10.32 SF	2.49 Ft.
	30x24	5.00 SF		
   	24x12	2.00 SF	10.19 SF	2.80 Ft.
	24x12	2.00 SF		
 	24x24	4.00 SF	10.19 SF	2.80 Ft.
	30x24	5.00 SF		

Renumbered: 8 of 10

10/18/2018 12:41:20 PM





LAST REVISION	DESCRIPTION:
11/01/17	11/01/19







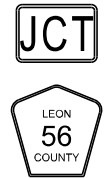
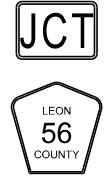



FY 2019-20  
STANDARD PLANS

SINGLE COLUMN GROUND SIGNS

INDEX	SHEET
700-010	7 of 9

	Size	Area	Total Area	Centroid
	24x12	2.00 SF	11.19 SF	2.76 Ft.
	24x12	2.00 SF		
	30x24	5.00 SF		
	21x15	2.19 SF		
Size	Area	Total Area	Centroid	
	30x15	3.13 SF	13.45 SF	3.16 Ft.
	30x15	3.13 SF		
	30x24	5.00 SF		
	21x15	2.19 SF		
Size	Area	Total Area	Centroid	
	21x15	2.19 SF	3.90 SF	1.57 Ft.
	18x18	1.71 SF		
Size	Area	Total Area	Centroid	
	21x15	2.19 SF	5.22 SF	1.72 Ft.
	24x24	3.03 SF		
Size	Area	Total Area	Centroid	
	21x15	2.19 SF	6.95 SF	1.87 Ft.
	30x30	4.76 SF		

	Size	Area	Total Area	Centroid
	18x18	1.71 SF	3.90 SF	1.26 Ft.
	21x15	2.19 SF		
Size	Area	Total Area	Centroid	
	24x24	3.03 SF	5.22 SF	1.62 Ft.
	21x15	2.19 SF		
Size	Area	Total Area	Centroid	
	30x30	4.76 SF	6.95 SF	1.97 Ft.
	21x15	2.19 SF		
Size	Area	Total Area	Centroid	
	24x12	2.00 SF	9.39 SF	2.87 Ft.
	24x12	2.00 SF		
	24x24	3.20 SF		
	21x15	2.19 SF		
Size	Area	Total Area	Centroid	
	24x12	2.00 SF	10.18 SF	2.84 Ft.
	24x12	2.00 SF		
	30x24	3.99 SF		
	21x15	2.19 SF		

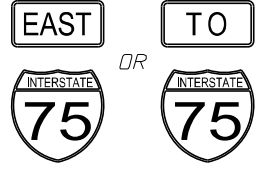
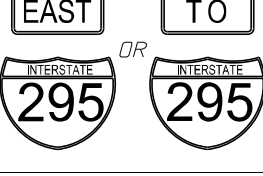
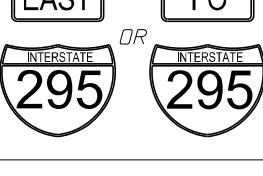
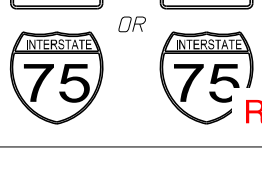
	Size	Area	Total Area	Centroid
	30x15	3.13 SF	12.44 SF	3.26 Ft.
	30x15	3.13 SF		
	30x24	3.99 SF		
Size	Area	Total Area	Centroid	
	21x15	2.19 SF	5.39 SF	1.75 Ft.
	24x24	3.20 SF		
Size	Area	Total Area	Centroid	
	21x15	2.19 SF	6.18 SF	1.67 Ft.
	30x24	3.99 SF		
Size	Area	Total Area	Centroid	
	24x12	2.00 SF	5.20 SF	1.67 Ft.
	24x24	3.20 SF		
Size	Area	Total Area	Centroid	
	24x12	2.00 SF	5.99 SF	1.60 Ft.
	30x24	3.99 SF		
Size	Area	Total Area	Centroid	
	30x15	3.13 SF	7.12 SF	1.81 Ft.
	30x24	3.99 SF		
Size	Area	Total Area	Centroid	
	30x15	3.13 SF	10.33 SF	2.27 Ft.
	36x36	7.20 SF		

Renumbered: 9 of 10

10/18/2018 12:41:20 PM

LAST REVISION	DESCRIPTION:
11/01/17	11/01/19

10/18/2018 12:41:21 PM

Size	Area	Total Area	Centroid
30x15	3.13 SF	12.12 SF	2.18 Ft.
45x36	8.99 SF		
24x12	2.00 SF	7.39 SF	2.30 Ft.
24x24	3.20 SF		
21x15	2.19 SF		
24x12	2.00 SF	8.18 SF	2.31 Ft.
30x24	3.99 SF		
21x15	2.19 SF		
30x15	3.13 SF	9.31 SF	2.55 Ft.
30x24	3.99 SF		
21x15	2.19 SF		
30x30	4.69 SF	6.69 SF	1.61 Ft.
24x12	2.00 SF		
30x30	4.69 SF	8.44 SF	1.77 Ft.
30x18	3.75 SF		
36x36	6.75 SF	10.50 SF	2.06 Ft.
30x18	3.75 SF		

Size	Area	Total Area	Centroid
30X30	4.69 SF	6.69 SF	1.61 Ft.
24X12	2.00 SF		
30X30	4.69 SF	8.44 SF	1.77 Ft.
30X18	3.75 SF		
36X36	6.75 SF	10.50 SF	2.06 Ft.
30X18	3.75 SF		
30X30	6.25 SF	8.25 SF	2.28 Ft.
24X12	2.00 SF		
36X36	9.00 SF	12.75 SF	2.84 Ft.
30X18	3.75 SF		
30X30	6.25 SF	10.25 SF	2.74 Ft.
24X24	4.00 SF		
36X36	9.00 SF	15.25 SF	3.29 Ft.
30X30	6.25 SF		

Size	Area	Total Area	Centroid
30X30	6.25 SF	9.25 SF	2.51 Ft.
24X18	3.00 SF		
36X36	9.00 SF	14.00 SF	3.06 Ft.
30X24	5.00 SF		

LAST REVISION 11/01/17  
 REVISION 11/01/19

DESCRIPTION:



FY 2019-20  
 STANDARD PLANS

SINGLE COLUMN GROUND SIGNS

INDEX  
 700-010

SHEET  
 9 of 9

Renumbered: 10 of 10

**STEP 1:** Calculate the area and the centroid for an individual sign or a sign cluster. Note that the centroid and areas have been calculated for frequently used sign clusters. These are shown on Sheets 7, 8, and 9.

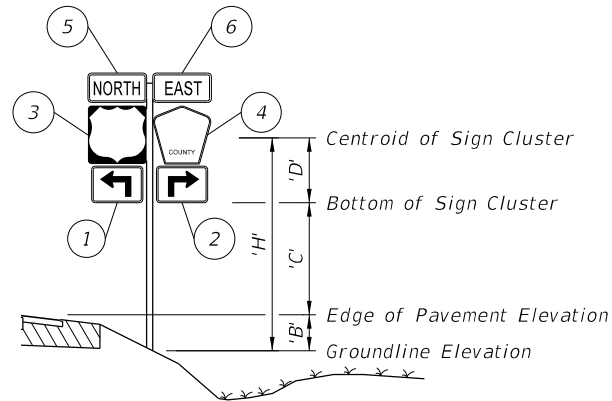

Size a x h	Centroid			'A <sub>n</sub> ' (in. <sup>2</sup> )	'X <sub>n</sub> ' x 'A <sub>n</sub> ' (in. <sup>3</sup> )	'Y <sub>n</sub> ' x 'A <sub>n</sub> ' (in. <sup>3</sup> )
	Local 'Y <sub>n</sub> '	Global 'X <sub>n</sub> '	Global 'Y <sub>n</sub> '			
(in. x in.)	(in.)	(in.)				
1 21 x 15	7.5	-10.5-1.5-1.5 = -13.5	7.5	315	-4,252.5	2,362.5
2 21 x 15	7.5	10.5+1.5+1.5 = 13.5	7.5	315	+4,252.5	2,362.5
3 24 x 24	12	-12-1.5 = -13.5	15+1+12 = 28	576	-7,776	16,128
4 24 x 24	12	12+1.5 = 13.5	15+1+12 = 28	436	5,886	12,208
5 24 x 12	6	-12-1.5 = -13.5	15+1+24+1+6 = 47	288	-3,888	13,536
6 24 x 12	6	12+1.5 = 13.5	15+1+24+1+6 = 47	288	3,888	13,536
<b>TOTALS</b>				<b>2,218</b>	<b>-1,890</b>	<b>60,133</b>

$$\Sigma ('A_n') = 2,218 \text{ in.}^2 = 15.4 \text{ ft.}^2$$

$$\Sigma ('X_n' \times 'A_n') = -1,890 \text{ in.}^3 = -1.09 \text{ ft.}^3$$

$$\Sigma ('Y_n' \times 'A_n') = 60,133 \text{ in.}^3 = 34.8 \text{ ft.}^3$$

$$'X_c' = \frac{\Sigma ('X_n' \times 'A_n')}{\Sigma 'A_n'} = -0.1 \text{ ft.}$$

$$'Y_c' = \frac{\Sigma ('Y_n' \times 'A_n')}{\Sigma 'A_n'} = 2.26 \text{ ft.}$$

**STEP 2:** Determine the height 'H' from groundline to the centroid of the individual sign or sign cluster.

Assume: 'B' = 1 ft., 'C' = 7 ft.  
Calculated: X<sub>c</sub> = -0.1 ft., Y<sub>c</sub> = 'D' 2.26 ft.

'H' = 'B' + 'C' + 'D' = 10.26 ft. ==> **USE 11 ft.**    Σ ('A<sub>n</sub>') = 15.4 ft.<sup>2</sup> ==> **USE 16 ft.<sup>2</sup>**

**STEP 3:** Refer to the Aluminum Column (Post) Selection Tables and find the intersection point. See Sheet 3.

		ALUMINUM COLUMN (POST) SELECTION TABLE												
		'H' (FT)												
		8 ft	9 ft	10 ft	11 ft	12 ft	13 ft	14 ft	15 ft	16 ft	17 ft	18 ft	19 ft	20 ft
TOTAL PANEL AREA (SF)	3 sf	2	2.5	2.5	2.5	3	3	3	3	3.5	3.5	3.5	3.5	3.5
	4 sf	2.5	2.5	3	3	3	3	3.5	3.5	3.5	3.5	3.5	3.5	3.5
	5 sf	2.5	3	3	3	3.5	3.5	3.5	3.5	3.5	3.5	3.5	3.5	4
	6 sf	3	3	3.5	3.5	3.5	3.5	3.5	3.5	3.5	3.5	4	4	4
	7 sf	3	3.5	3.5	3.5	3.5	3.5	3.5	3.5	4	4	4	4	4
	8 sf	3.5	3.5	3.5	3.5	3.5	3.5	3.5	4	4	4	4	4	4
	9 sf	3.5	3.5	3.5	3.5	3.5	3.5	4	4	4	4	4	4	4
	10 sf	3.5	3.5	3.5	3.5	3.5	4	4	4	4	4	4	4.5	4.5
	11 sf	3.5	3.5	3.5	3.5	4	4	4	4	4	4	4	4.5	4.5
	12 sf	3.5	3.5	3.5	4	4	4	4	4	4	4	4.5	4.5	4.5
	13 sf	3.5	3.5	4	4	4	4	4	4	4	4.5	4.5	4.5	5
	14 sf	3.5	3.5	4	4	4	4	4	4	4.5	4.5	4.5	5	5
	15 sf	3.5	4	4	4	4	4	4	4.5	4.5	4.5	5	5	5
	16 sf	3.5	4	4	4	4	4	4	4.5	4.5	5	5	5	6
	17 sf	4	4	4	4	4	4	4	4.5	4.5	5	5	6	6
	18 sf	4	4	4	4	4	4	4.5	4.5	4.5	5	5	6	6
19 sf	4	4	4	4	4	4	4.5	4.5	4.5	5	5	6	6	
20 sf	4	4	4	4	4	4.5	4.5	4.5	5	5	6	6	6	
21 sf	4	4	4	4	4.5	4.5	5	5	5	6	6	6	6	
22 sf	4	4	4	4.5	4.5	4.5	5	5	6	6	6	6	6	
23 sf	4	4	4	4.5	4.5	5	5	5	6	6	6	6	6	
24 sf	4	4	4.5	4.5	4.5	5	5	6	6	6	6	6	6	
25 sf	4	4	4.5	4.5	5	5	5	6	6	6	6	6	8	
26 sf	4	4.5	4.5	4.5	5	5	5	6	6	6	6	8	8	
27 sf	4	4.5	4.5	4.5	5	5	6	6	6	6	6	8	8	
28 sf	4	4.5	4.5	5	5	5	6	6	6	6	6	8	8	
29 sf	4.5	4.5	4.5	5	5	6	6	6	6	6	6	8	8	
30 sf	4.5	4.5	5	5	5	6	6	6	6	6	6	8	8	

For 'H' = 11 ft., Area = 16 ft.<sup>2</sup>

- Refer to the Aluminum Column (Post) Selection Table, from Sheet 3 and shown here for reference.

- To determine the required post size, find the intersection of the row labeled "16 SF" and the column labeled "11 FT". For the example the intersection value is "4" (4" OD).

- In the Column (Post) and Foundation Table, the value "4" shows the design requires a 4.0" diameter and 1/4" thick Aluminum Column (Post) and a 2.0' diameter and 3.5' deep Concrete Foundation and 3.0' Stub.

**STEP 4:** For sign assemblies with signs oriented in two directions, only the sign with the largest area should be analyzed to determine the Column (Post) requirements.

SHEET	CONTENTS
1	General Notes and Design Example
2	Design Example - Centroid
3	Column and Foundation Tables
4	Slip Base and Foundation Details
5	Driven Post and Soil Plate Detail
6	Wind Beam Connection
7, 8 & 9	Frequently Used Sign Clusters

**GENERAL NOTES:**

- Shop Drawings:  
This Index is considered fully detailed. Submit Shop Drawings only for minor modifications not detailed in the Plans.
- Aluminum Sign, Wind Beams and Column (Post) Materials:  
A. Aluminum Plates: ASTM B209, Alloy 6061-T6  
B. Aluminum Bars and Extruded Shapes: ASTM B221, Alloy 6061-T6  
C. Aluminum Structural Shapes: ASTM B308 Alloy 6061-T6  
D. Cast Aluminum: ASTM B26 Alloy A356-T6  
E. Aluminum Weld Material: ER 5556 or 5356
- Sign Mounting Bolts, Nuts and Washers:  
A. Aluminum Button Head and Flat Head Bolts: ASTM F468 Alloy 2024-T4  
B. Aluminum Hex Nuts: ASTM F467 Alloy 6061-T6 or 6262-T9  
C. Aluminum Washers: ASTM B221, Alloy 7075-T6
- Stainless Steel Bolts, Nuts and Washers may be used in lieu of the Aluminum button head and flat head bolts as follows:  
A. Stainless Steel Bolts: ASTM F 593 Alloy Group 2, Condition A, CW1 or SH1  
B. Stainless Steel Nuts: ASTM F594
- Sign Column (Post) Bolts, Nuts and Washers:  
A. Galvanized U-Bolt (Column): ASTM A449 or ASTM A193 B7 according to ASTM F2329 with double nuts.  
B. Aluminum Bolts (Sleeve): ASTM F468, Alloy 6061-T6 or 2024-T4 with Hex Nuts F467 6061-T6 or 6262-T9 and Washers B221, Alclad 2024-T4  
C. Galvanized High Strength Hex Head Bolts (BaseBolts): ASTM F3125, Grade A325, Type 1  
D. Galvanized Hex Nuts: ASTM A563 Grade DH  
E. Galvanized Washers: ASTM F436  
F. Galvanized Bolts (Sleeve): ASTM A307 with Galvanized Hex Nuts and Washers
- Coatings:  
A. Aluminum Fasteners: Anodic coating (0.0002 inches min.) and chromate sealed  
B. High Strength Steel Bolts Nuts and Washers: ASTM F2329  
C. All other steel items (excluding stainless steel): Hot-dip Galvanize - ASTM A123  
D. Repair damaged galvanizing in accordance with Specification 562
- BREAKAWAY SUPPORTS REQUIREMENTS: Install non-frangible aluminum column (post) (larger than 3 1/2") with breakaway supports as shown on Sheet 4. Signs shielded by barrier wall or guardrail do not require breakaway support.

**GUIDE TO USE THIS INDEX**

**GENERAL NOTES AND DESIGN EXAMPLE**

8/14/2019 3:02:34 PM

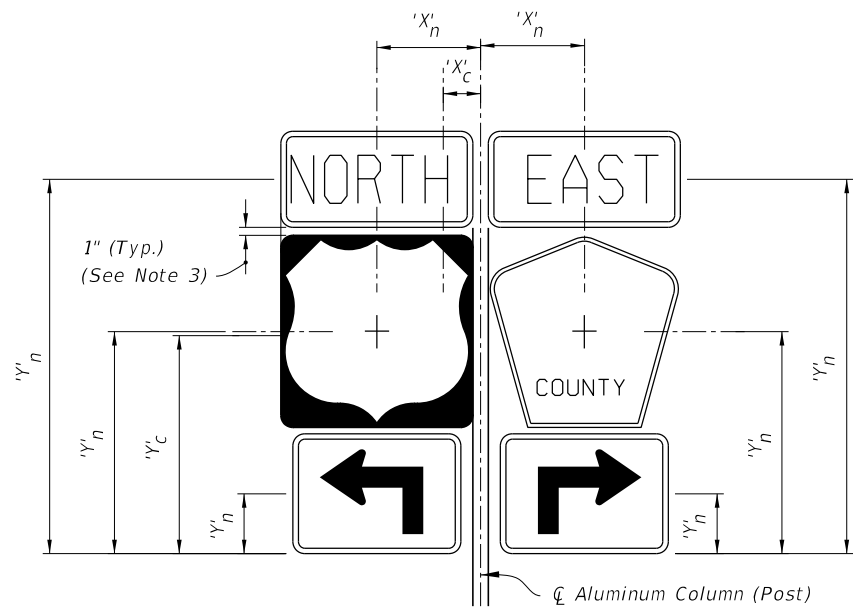

**SIGN CLUSTER**

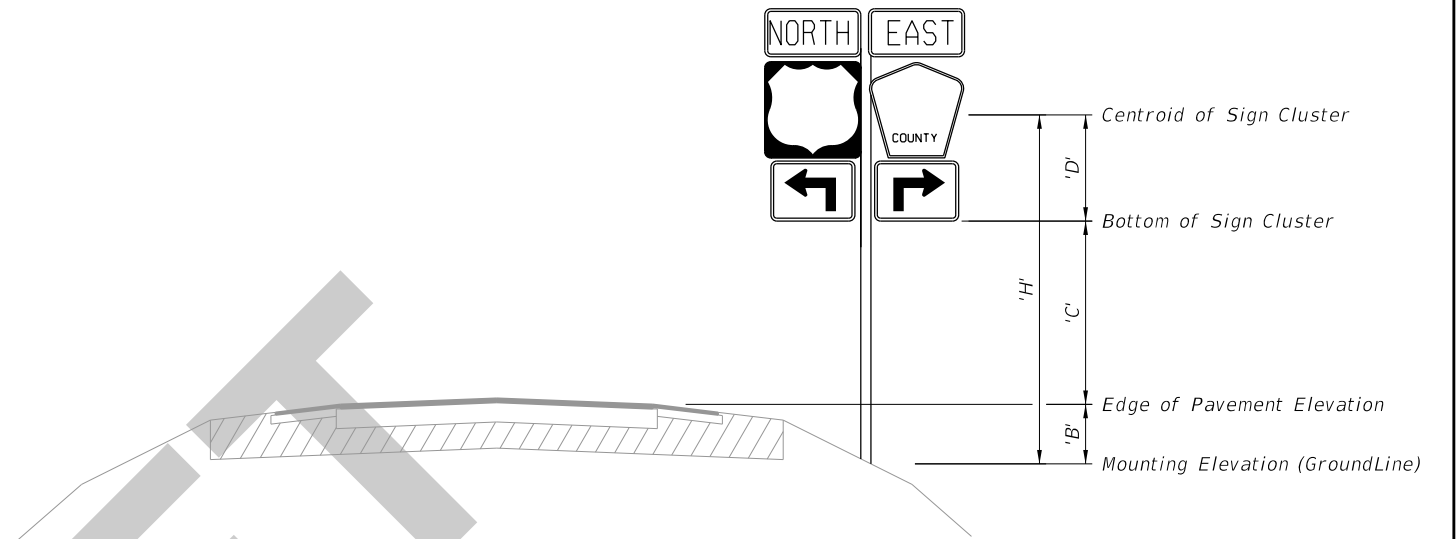

**TYPICAL SECTION**

$$'X'_c = \frac{\sum ('X'_n \times 'A'_n)}{\sum 'A'_n} \quad 'C' = 'Y'_c = \frac{\sum ('Y'_n \times 'A'_n)}{\sum 'A'_n}$$

- 'A'<sub>n</sub> = Area of individual sign
- 'B' = Height of the edge of pavement from the mounting elevation
- 'C' = Height of the the bottom of the sign or cluster from the edge of pavement elevation
- 'D' = Height of the centroid of the sign or cluster from the bottom of the sign or cluster
- h = Individual sign height
- 'H' = Height of sign or cluster centroid from groundline
- a = Individual sign width
- 'X'<sub>c</sub> = Centroid horizontal location of sign or cluster from  $\phi$  Aluminum Column (Post)
- 'Y'<sub>c</sub> = Centroid height of sign or cluster from bottom of sign cluster
- 'X'<sub>n</sub> = Individual sign centroid horizontal location from  $\phi$  Aluminum Column (Post)
- 'Y'<sub>n</sub> = Individual Sign centroid height from bottom of sign cluster

**NOTES:**

1. For 'B' & 'C' see Index 700-101 and Roadway Plans.
2. Do not exceed an area of 30 SF or a width of 60 inches for a sign or a sign cluster, including rotated sign panels.
3. Vertical sign spacing (1" shown on Sign Cluster detail) also applies to rotated signs.

**CALCULATION OF SIGN CLUSTER CENTROID**

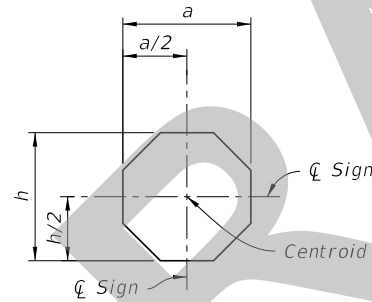

**STOP**

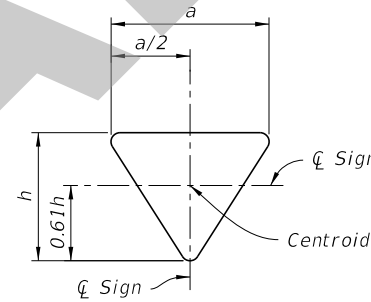

**YIELD**

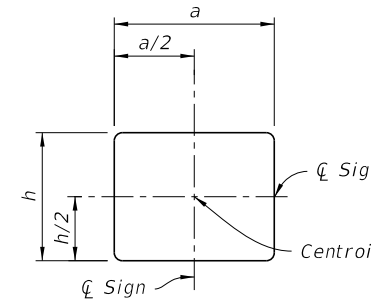

**RECTANGLE**

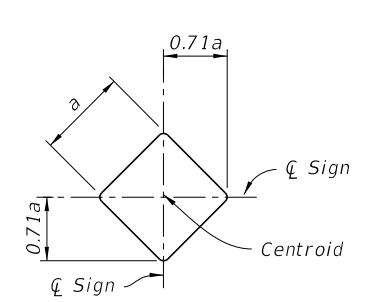

**DIAMOND**

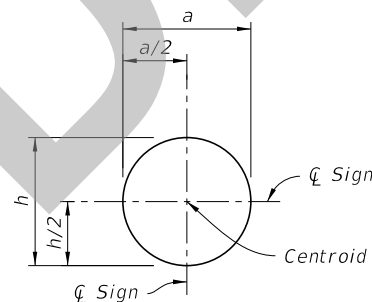

**RAILROAD**

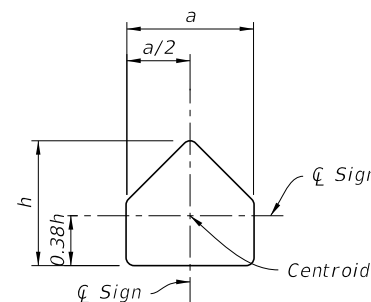

**SCHOOL**

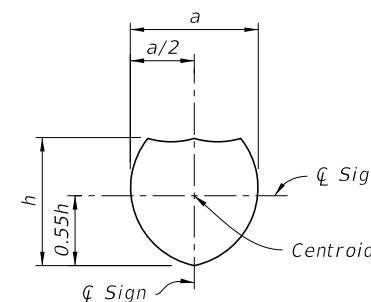

**SHIELD**

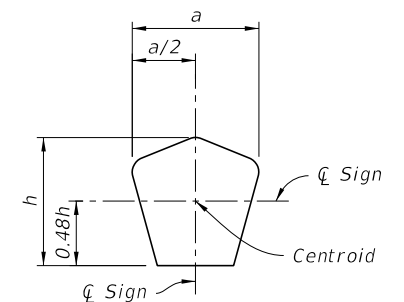

**COUNTY**

8/14/2019 3:02:35 PM

**DESIGN EXAMPLE - CENTROID**

LAST REVISION 11/01/19	REVISION	DESCRIPTION:		FY 2020-21 STANDARD PLANS	SINGLE COLUMN GROUND SIGNS	INDEX 700-010	SHEET 2 of 10
---------------------------	----------	--------------	--	------------------------------	----------------------------	------------------	------------------

ALUMINUM COLUMN (POST) SELECTION TABLE (O.D. in.)

TOTAL PANEL AREA (SF)		'H' (FT)												
		8 ft	9 ft	10 ft	11 ft	12 ft	13 ft	14 ft	15 ft	16 ft	17 ft	18 ft	19 ft	20 ft
		3 sf	2	2.5	2.5	2.5	3	3	3	3	3.5	3.5	3.5	3.5
4 sf	2.5	2.5	3	3	3	3	3.5	3.5	3.5	3.5	3.5	3.5	3.5	
5 sf	2.5	3	3	3	3.5	3.5	3.5	3.5	3.5	3.5	3.5	4	4	
6 sf	3	3	3.5	3.5	3.5	3.5	3.5	3.5	3.5	3.5	4	4	4	
7 sf	3	3.5	3.5	3.5	3.5	3.5	3.5	3.5	4	4	4	4	4	
8 sf	3.5	3.5	3.5	3.5	3.5	3.5	3.5	4	4	4	4	4	4	
9 sf	3.5	3.5	3.5	3.5	3.5	3.5	4	4	4	4	4	4	4	
10 sf	3.5	3.5	3.5	3.5	3.5	4	4	4	4	4	4	4.5	4.5	
11 sf	3.5	3.5	3.5	3.5	4	4	4	4	4	4	4.5	4.5	4.5	
12 sf	3.5	3.5	3.5	4	4	4	4	4	4	4	4.5	4.5	4.5	
13 sf	3.5	3.5	4	4	4	4	4	4	4	4.5	4.5	4.5	5	
14 sf	3.5	3.5	4	4	4	4	4	4	4.5	4.5	4.5	5	5	
15 sf	3.5	4	4	4	4	4	4	4.5	4.5	4.5	5	5	5	
16 sf	3.5	4	4	4	4	4	4	4.5	4.5	5	5	5	6	
17 sf	4	4	4	4	4	4	4.5	4.5	4.5	5	5	6	6	
18 sf	4	4	4	4	4	4.5	4.5	4.5	5	5	5	6	6	
19 sf	4	4	4	4	4	4.5	4.5	4.5	5	5	6	6	6	
20 sf	4	4	4	4	4.5	4.5	4.5	5	5	5	6	6	6	
21 sf	4	4	4	4	4.5	4.5	5	5	5	6	6	6	6	
22 sf	4	4	4	4.5	4.5	4.5	5	5	6	6	6	6	6	
23 sf	4	4	4	4.5	4.5	5	5	5	6	6	6	6	6	
24 sf	4	4	4.5	4.5	4.5	5	5	6	6	6	6	6	6	
25 sf	4	4	4.5	4.5	5	5	5	6	6	6	6	6	8	
26 sf	4	4.5	4.5	4.5	5	5	5	6	6	6	6	8	8	
27 sf	4	4.5	4.5	4.5	5	5	6	6	6	6	6	8	8	
28 sf	4	4.5	4.5	5	5	5	6	6	6	6	6	8	8	
29 sf	4.5	4.5	4.5	5	5	6	6	6	6	6	8	8	8	
30 sf	4.5	4.5	5	5	5	6	6	6	6	6	8	8	8	

FOUNDATION TABLE

Column (Post) Size		Foundation Alternatives				
Outside Diameter (in)	Wall Thk. (in)	Driven Post *		Concrete (Class I)		
		Embedment Depth (ft) without Soil Plate	Embedment Depth (ft) with Soil Plate	Diameter (ft)	Embedment Depth (ft)	Stub Length (ft)
2.0	1/8	4.5	2.5	---	---	---
2.5	1/8	5.0	3.0	---	---	---
3.0	1/8	5.0	3.5	---	---	---
3.5	3/16	6.0	4.5	---	---	---
4.0	1/4	---	---	2.0	3.5	3.0
4.5	1/4	---	---	2.0	4.0	3.0
5.0	1/4	---	---	2.0	4.5	3.0
6.0	1/4	---	---	2.0	5.0	3.0
8.0	1/4	---	---	2.0	5.5	3.0

\* INSTALLING FRANGIBLE COLUMN SUPPORTS:

Columns (posts) 3 1/2" O.D. and less are considered frangible and may be installed either by driving the post or setting the posts in preformed holes. Backfill preformed holes with suitable material tamped in layers not thicker than 6" (to provide adequate compaction) or filled with flowable fill or bagged concrete.

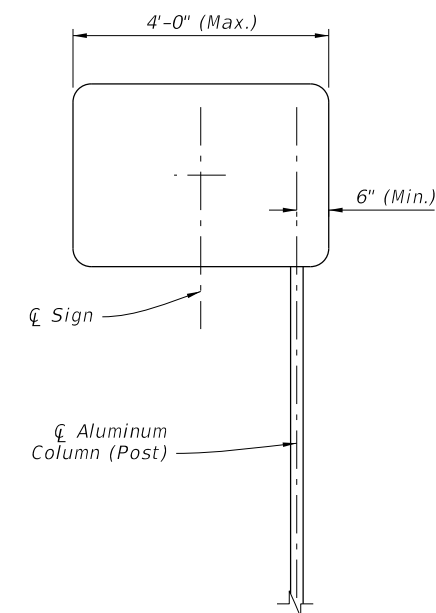

OFFSET SIGN

NOTE:

1. For offset sign placement see Index 700-101.
2. For signs with widths greater than 4' see Index 700-011.
3. Offset signs with driven posts require a soil plate.

COLUMN AND FOUNDATION TABLES

8/14/2019 3:02:36 PM

LAST REVISION 11/01/19	DESCRIPTION:	 FY 2020-21 STANDARD PLANS	SINGLE COLUMN GROUND SIGNS	INDEX 700-010	SHEET 3 of 10
---------------------------	--------------	--	----------------------------	------------------	------------------

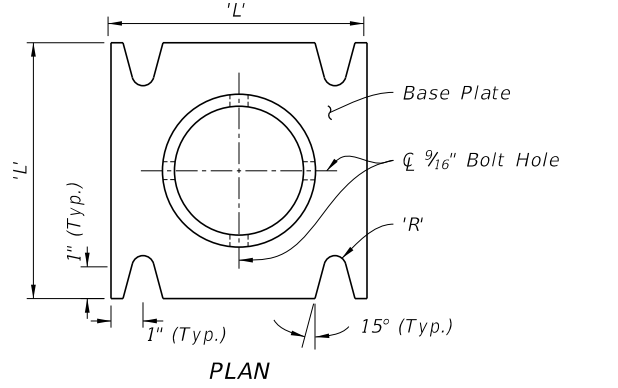
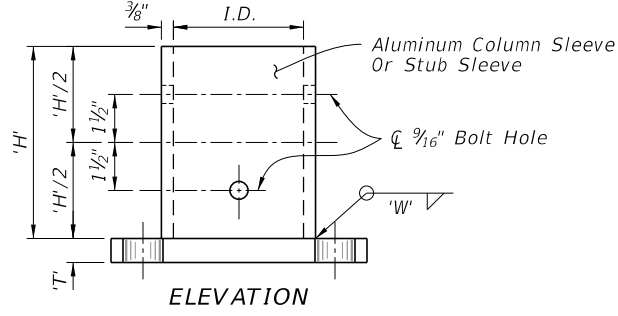

**STUB/SLEEVE & BASE PLATE DETAILS**

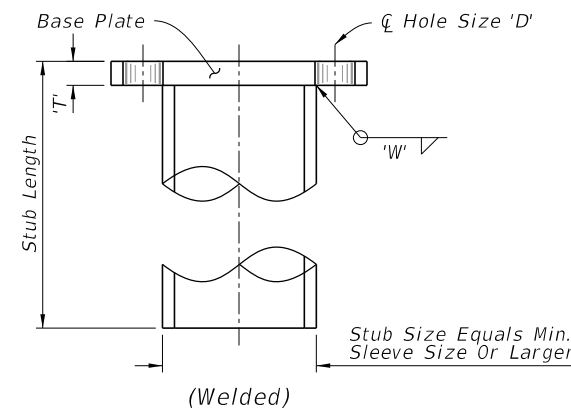

**STUB DETAIL**

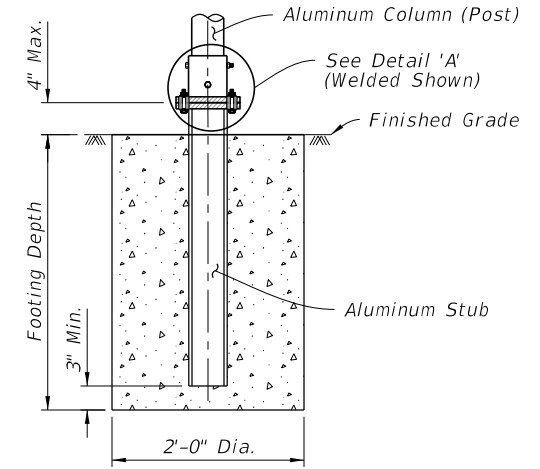

**SLIP BASE AND FOUNDATION DETAIL (Non-Frangible Column, Typ.)**

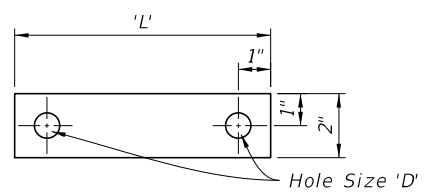

**BOLT KEEPER PLATE DETAIL**

28 Ga. Thick Aluminum Strip  
2 Req. Per Base

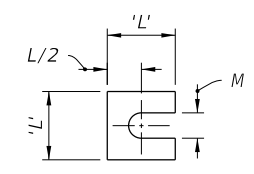

**SHIM DETAIL**

Provide 2~0.0149" Thick (28 gauge)  
and 2~0.0329" Thick (21 gauge)  
Brass Shims Per Post

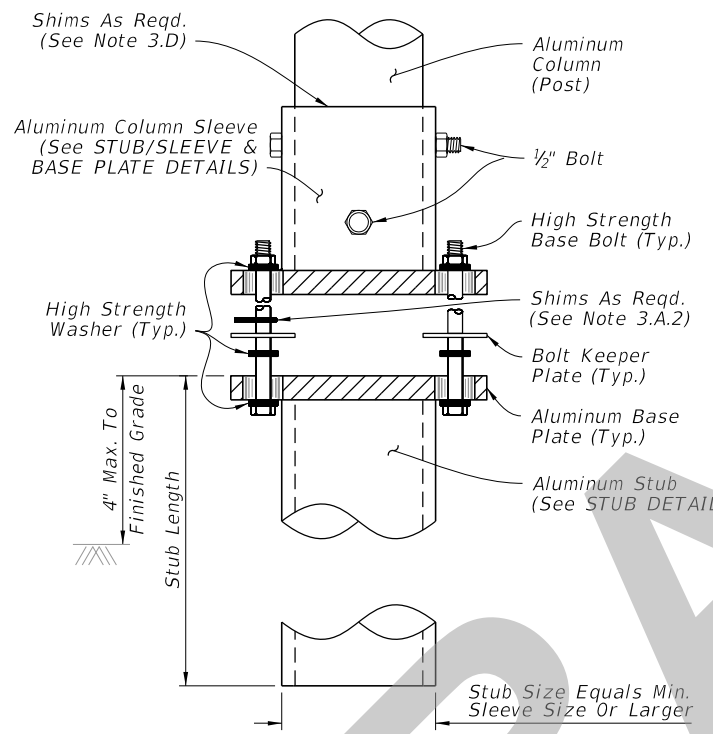

**WELDED STUB BASE**

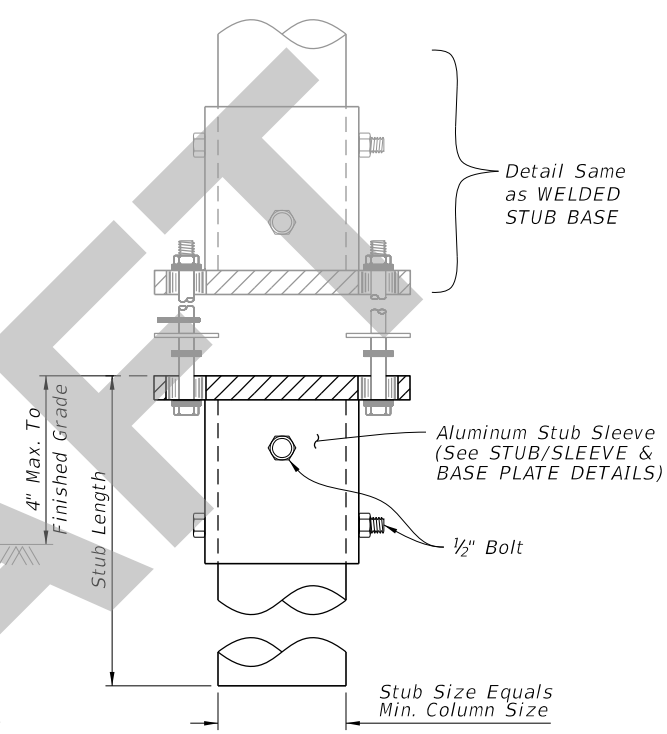

**BOLTED STUB/SLEEVE BASE**

**DETAIL 'A'**

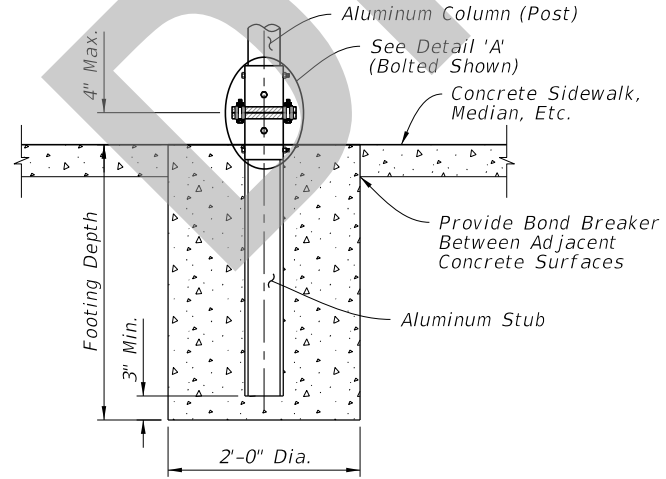

**SLIP BASE AND FOUNDATION DETAIL IN CONCRETE (Non-Frangible Column In Crossovers, Medians & Sidewalks)**

**NOTES:**

- Foundation Notes for Slip Base:**
  - Place Stub into concrete foundation given in the FOUNDATION TABLE using Class 1 Concrete.
- Slip Base Fabrication Notes:**
  - The difference between the O.D. of the post and I.D. of the Sleeve must be 1/16" or less.
  - Either a Welded Stub Base or Bolted Stub/Sleeve Base may be used in Slip Base.
  - For cast base plates bolted to foundation stubs, use a foundation stub the same size as the sign column (Post).
- Slip-Base Assembly Instructions:**
  - Assemble the Slip Base as follows:
    - Insert Post into Sleeve and connect using 2 ~ 1/2" diameter Sleeve Bolts.
    - Assemble top base plate to bottom Base Plate using Base Bolts (High strength) with 3 washers per bolt. (See Detail 'A'):
      - Place one washer on each Base Bolt between the bottom Base Plate and the Base Bolt head.
      - Place the next washer between the Bottom Base Plate and the Bolt Keeper Plate.
      - Use brass or galvanized steel shims to plumb the post.
      - Add the top base plate section.
      - Place the third washer between the Top Base Plate and the Nut.
  - Orient the Bolt Keeper Plates in the Direction of Traffic.
  - Tighten Base Bolts as follows:
    - Tighten Base Bolts to the maximum possible with a 12" to 15" wrench (this will bed the washers and shims and clear the bolt threads).
    - Loosen each Base Bolt one turn.
    - Under the supervision of the Engineer, use a calibrated wrench to tighten bolts to the torque prescribed in the SLIP BASE DETAILS Table. Over tightened Base Bolts are not permitted.
    - Distort bolt threads at the junction with nuts to prevent loosening. Repair damaged galvanizing.
  - Obtain a tight sleeve connection by placing 4 galvanized steel shims between the column (post) and sleeve. Space the shims evenly around the perimeter of the column (1 between each bolt hole, 4 total). Use shims that are 1" shorter than the height of the sleeve.

Column (Post) Size		SLIP BASE DETAILS												
Outside Dia.	Wall Thickness	Sleeve I.D. (Max.)	Sleeve Height 'H'	Weld 'W'	Base Plate		Radius 'R'	Base Bolt		Base Plate Torque		Hole Size 'D'	SHIM	
					'L'	'T'		Size	Length	ft-lbs	in.-lbs		L	M
4"	1/4"	4 1/16"	6"	1/4"	8"	3/4"	1 1/32"	5/8"	3"	29	345	1 1/16"	1 3/8"	1 1/16"
4 1/2"	1/4"	4 7/16"	6"	1/4"	8"	7/8"	1 1/32"	5/8"	3 1/4"	29	345	1 1/16"	1 3/8"	1 1/16"
5"	1/4"	5 1/16"	7"	1/4"	8"	7/8"	1 1/32"	5/8"	3 1/4"	29	345	1 1/16"	1 3/8"	1 1/16"
6"	1/4"	6 1/16"	8"	1/4"	9"	1"	1 3/32"	3/4"	3 1/2"	46	554	1 3/16"	1 3/4"	1 3/16"
8"	1/4"	8 1/16"	10"	1/4"	11"	1"	1 5/32"	7/8"	3 3/4"	53	640	1 5/16"	2 3/8"	1 1/16"

**SLIP BASE AND FOUNDATION DETAILS**

8/14/2019 3:02:38 PM

LAST REVISION	DESCRIPTION:
11/01/19	

FY 2020-21
   
 STANDARD PLANS

SINGLE COLUMN GROUND SIGNS

INDEX	SHEET
700-010	4 of 10

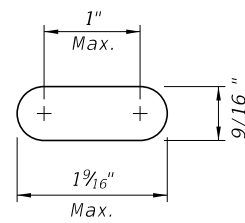

Optional Slotted Holes

DETAIL "B"

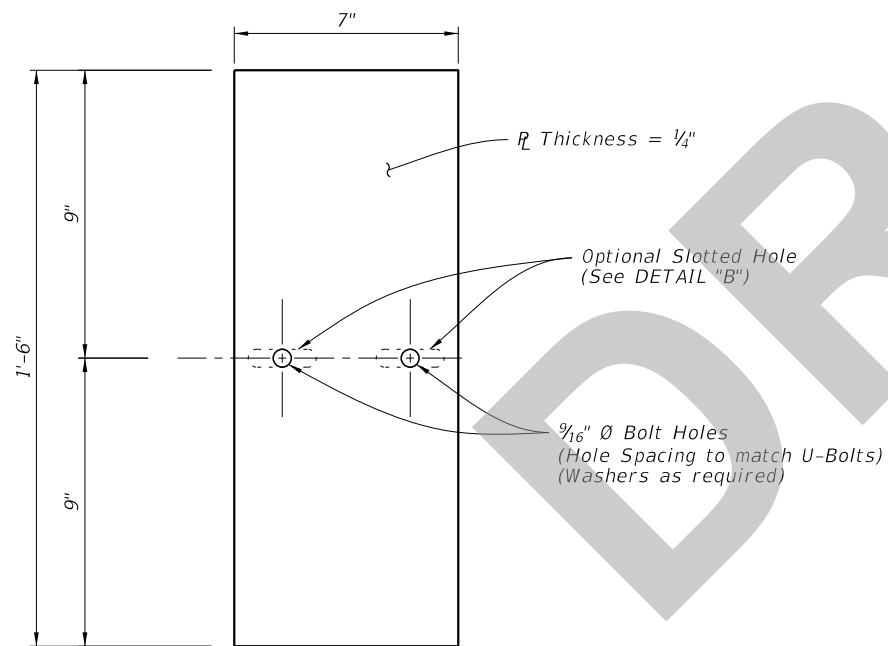

ALUMINUM SOIL PLATE DETAIL

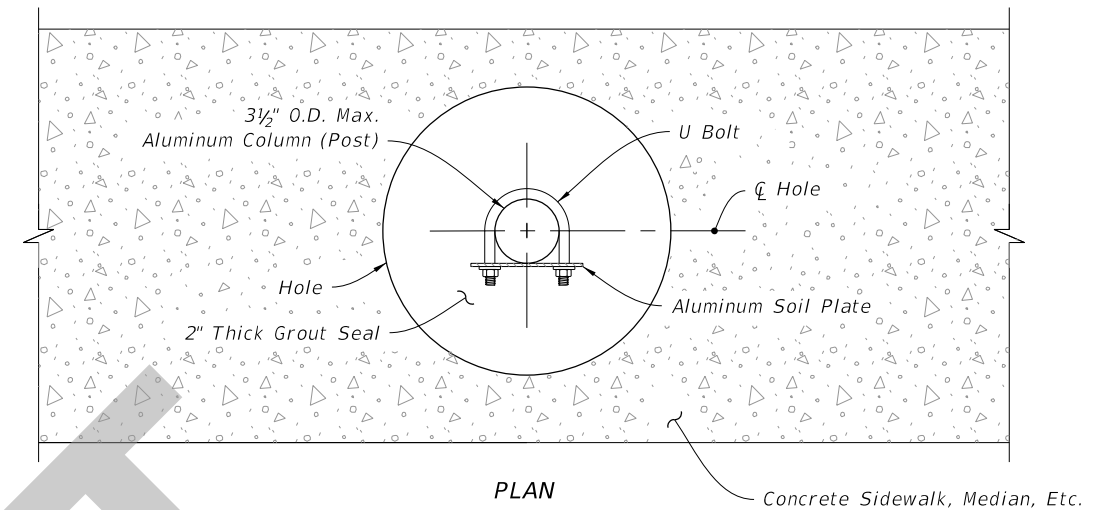

PLAN

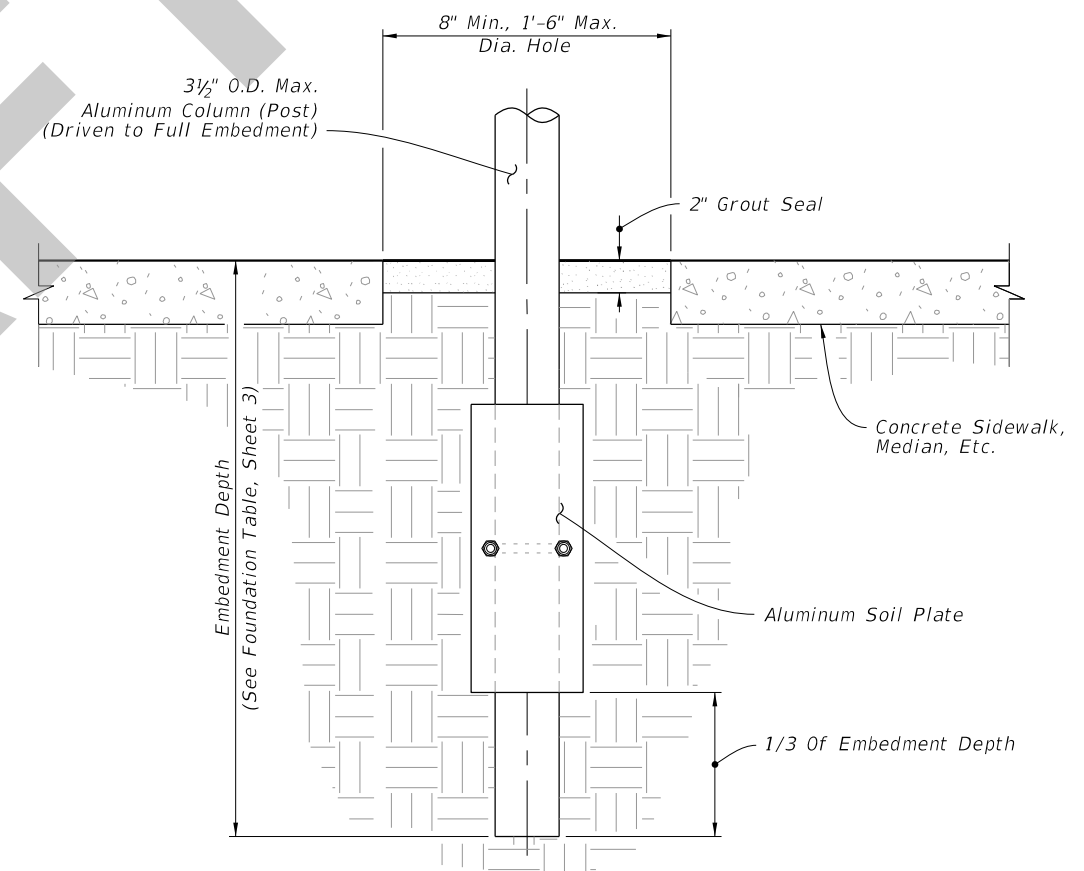

ELEVATION

DRIVEN POST DETAIL

(Frangible Post In Crossovers, Medians & Sidewalks)

DRIVEN POST AND SOIL PLATE DETAIL

8/14/2019 3:02:39 PM

LAST REVISION 11/01/19	REVISION	DESCRIPTION:
---------------------------	----------	--------------



FY 2020-21  
STANDARD PLANS

SINGLE COLUMN GROUND SIGNS

INDEX  
700-010

SHEET  
5 of 10



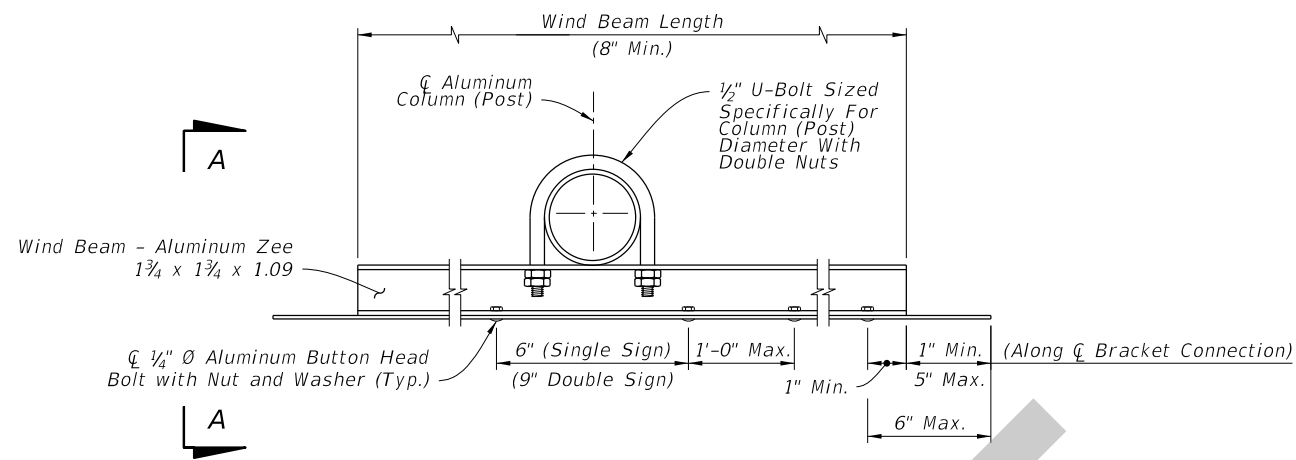

WIND BEAM CONNECTIONS DETAILS

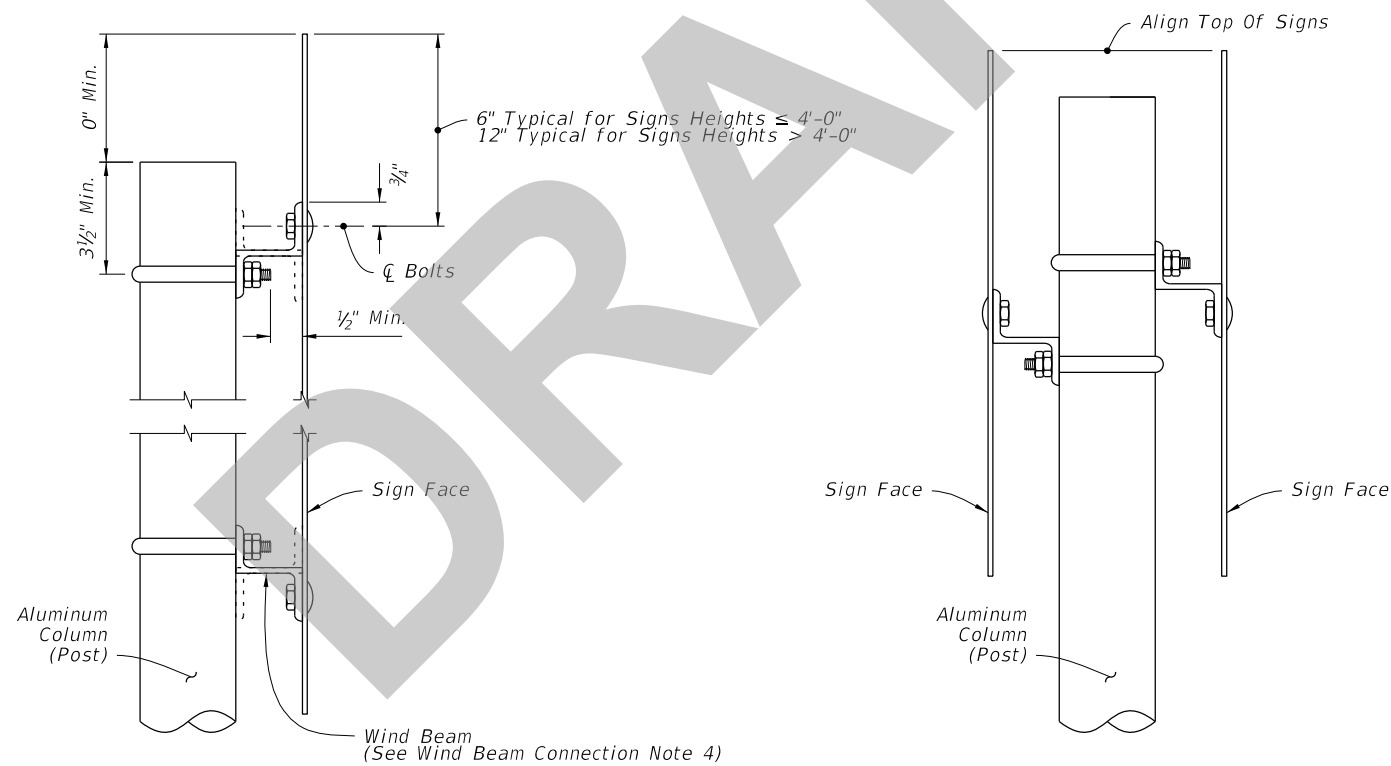

SINGLE SIGN DETAIL

BACK-TO-BACK SIGN DETAIL

NOTE: Use the area and the centroid location of the largest sign to determine aluminum column (post) size.

NOTES:

1. 5/16" Ø Stainless Steel Hex Head Bolts with Flat Washer under Head and Washer under Nut may be used in lieu of 1/4" Ø Aluminum Button or Flat Head Bolts.
2. Use Nylon washers (provided by the sheeting supplier) under the button bolt heads to protect sign sheeting.
3. Slots up to 2" long are allowed in wind beams to accommodate U-Bolts for varying Column (Post) diameters.
4. Wind beams may be oriented in either direction.
5. For signs greater than 66" in height, install a third wind beam evenly spaced between the top and bottom wind beams. For signs up to 12" in height, use only one wind beam at Ø Sign. Install two wind beams on signs with heights greater than 12" and less than or equal to 66".

VIEW A-A

8/14/2019 3:02:39 PM

WIND BEAM CONNECTION

LAST REVISION 11/01/19	DESCRIPTION:
---------------------------	--------------



FY 2020-21  
STANDARD PLANS

SINGLE COLUMN GROUND SIGNS

INDEX  
700-010

SHEET  
6 of 10

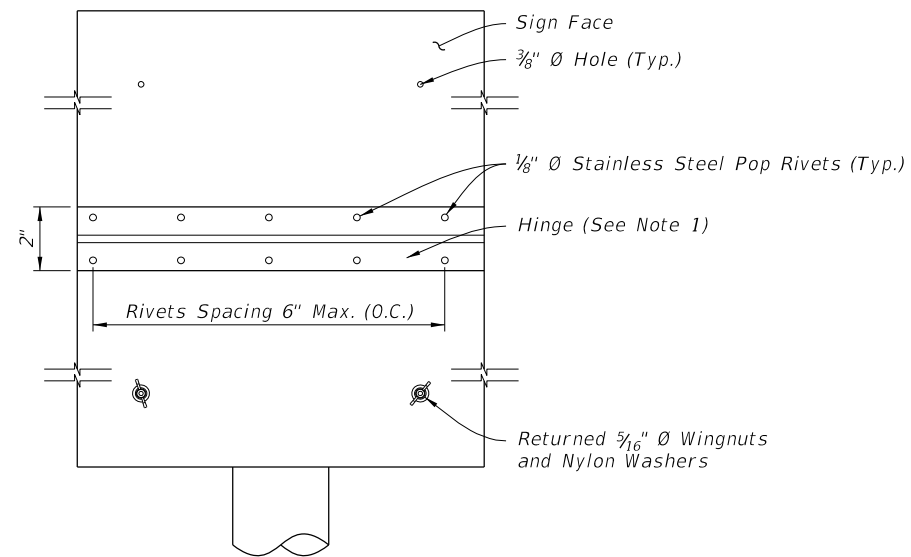

SIGN PANEL FRONT VIEW

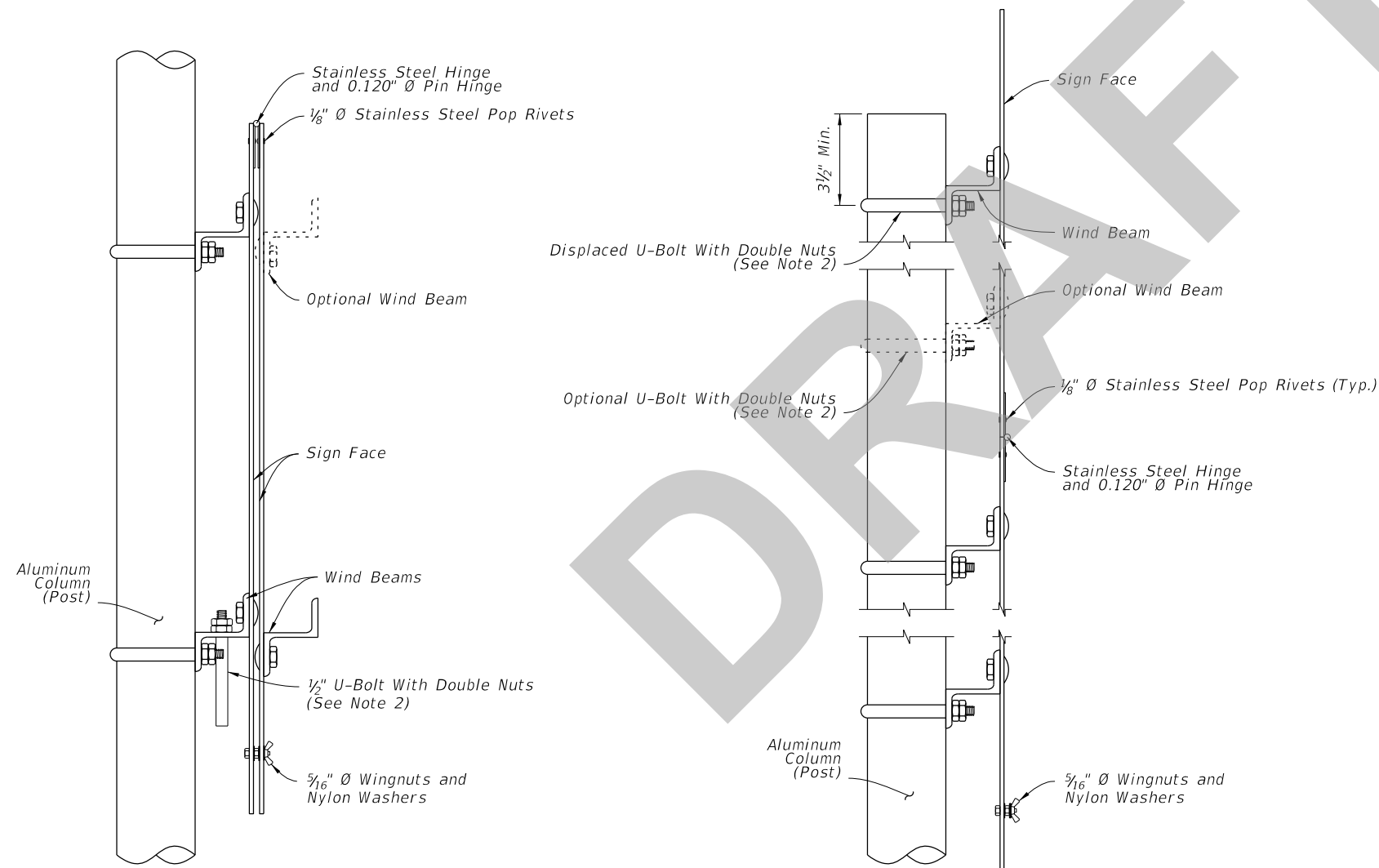

UNDEPLOYED SIGN DETAIL

DEPLOYED SIGN DETAIL

SIGN PANEL SIDE VIEW

**NOTES:**

1. Provide a continuous hinge of stainless steel with minimum 0.060" leaf thickness, 2" open width and 0.120" pin diameter.
2. Stowed 1 or 2 pcs of U-Bolt sized specifically for column (post) diameter with Double Nuts. Stowed on Wind Beam and displaced while deploying the sign.
3. Wingnuts at the bottom corners hold the panel closed when in the folded position. When the sign is open, store wingnuts in the bottom corners.

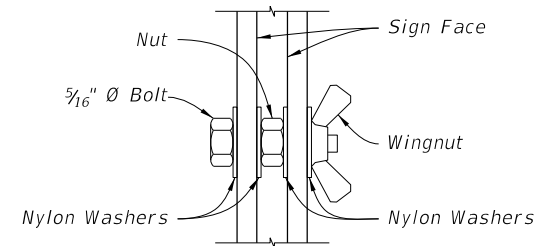

DETAIL "A"

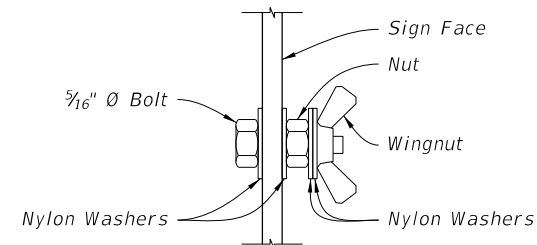

DETAIL "B"

**WIND BEAM CONNECTION FOR FLIP UP SIGN**

8/14/2019 3:02:40 PM

LAST REVISION 11/01/19	REVISION	DESCRIPTION:
---------------------------	----------	--------------

















FY 2020-21  
STANDARD PLANS























SINGLE COLUMN GROUND SIGNS























INDEX  
700-010

SHEET  
7 of 10

8/14/2019 3:02:41 PM

	Size	Area	Total Area	Centroid
 	36x12	3.00 SF	6.31 SF	1.75 Ft.
	24x24	3.31 SF		
 	36x12	3.00 SF	8.18 SF	1.92 Ft.
	30x30	5.18 SF		
 	36x12	3.00 SF	10.46 SF	2.10 Ft.
	36x36	7.46 SF		
 	36x12	3.00 SF	16.25 SF	2.48 Ft.
	48x48	13.25 SF		
 	24x24	3.31 SF	6.31 SF	1.71 Ft.
	24x18	3.00 SF		
 	30x30	5.18 SF	10.18 SF	2.19 Ft.
	30x24	5.00 SF		
 	36x36	7.46 SF	12.46 SF	2.55 Ft.
	30x24	5.00 SF		

	Size	Area	Total Area	Centroid
  	36x12	3.00 SF	13.18 SF	2.87 Ft.
	30x30	5.18 SF		
  	30x24	5.00 SF	15.46 SF	3.15 Ft.
	36x36	7.46 SF		
  	36x12	3.00 SF	6.19 SF	1.60 Ft.
	21x15	2.19 SF		
 	24x24	4.00 SF	7.19 SF	1.52 Ft.
	21x15	2.19 SF		
 	30x24	5.00 SF	6.00 SF	1.53 Ft.
	24x12	2.00 SF		
  	24x24	4.00 SF	7.00 SF	1.45 Ft.
	24x12	2.00 SF		
  	30x24	5.00 SF	8.13 SF	1.66 Ft.
	30x15	3.13 SF		
  	30x24	5.00 SF		
	30x15	3.13 SF		

	Size	Area	Total Area	Centroid
 	24x24	4.00 SF	6.19 SF	1.73 Ft.
	21x15	2.19 SF		
 	30x24	5.00 SF	7.19 SF	1.81 Ft.
	21x15	2.19 SF		
    	24x12	2.00 SF	8.19 SF	2.26 Ft.
	24x24	4.00 SF		
    	24x12	2.00 SF	9.19 SF	2.27 Ft.
	30x24	5.00 SF		
    	30x15	3.13 SF	10.32 SF	2.49 Ft.
	30x24	5.00 SF		
   	24x12	2.00 SF	10.19 SF	2.80 Ft.
	24x12	2.00 SF		
	24x24	4.00 SF		
	21x15	2.19 SF		

**DRAFT - 3**

LAST REVISION 11/01/19	DESCRIPTION:
---------------------------	--------------





FY 2020-21  
STANDARD PLANS





SINGLE COLUMN GROUND SIGNS

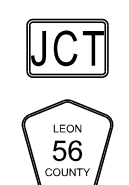
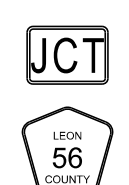
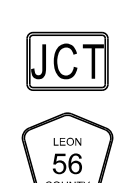

INDEX  
700-010

SHEET  
8 of 10

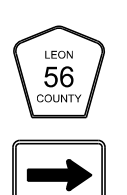
8/14/2019 3:02:42 PM

	Size	Area	Total Area	Centroid
	24x12	2.00 SF	11.19 SF	2.76 Ft.
	24x12	2.00 SF		
	30x24	5.00 SF		
	21x15	2.19 SF		
	Size	Area	Total Area	Centroid
	30x15	3.13 SF	13.45 SF	3.16 Ft.
	30x15	3.13 SF		
	30x24	5.00 SF		
	21x15	2.19 SF		
	Size	Area	Total Area	Centroid
	21x15	2.19 SF	3.90 SF	1.57 Ft.
	18x18	1.71 SF		
	Size	Area	Total Area	Centroid
	21x15	2.19 SF	5.22 SF	1.72 Ft.
	24x24	3.03 SF		
	Size	Area	Total Area	Centroid
	21x15	2.19 SF	6.95 SF	1.87 Ft.
	30x30	4.76 SF		

	Size	Area	Total Area	Centroid
	18x18	1.71 SF	3.90 SF	1.26 Ft.
	21x15	2.19 SF		
	Size	Area	Total Area	Centroid
	24x24	3.03 SF	5.22 SF	1.62 Ft.
	21x15	2.19 SF		
	Size	Area	Total Area	Centroid
	30x30	4.76 SF	6.95 SF	1.97 Ft.
	21x15	2.19 SF		
	Size	Area	Total Area	Centroid
	24x12	2.00 SF	9.39 SF	2.87 Ft.
	24x12	2.00 SF		
	24x24	3.20 SF		
	21x15	2.19 SF		
	Size	Area	Total Area	Centroid
	24x12	2.00 SF	10.18 SF	2.84 Ft.
	24x12	2.00 SF		
	30x24	3.99 SF		
	21x15	2.19 SF		

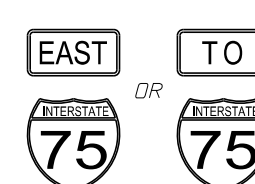
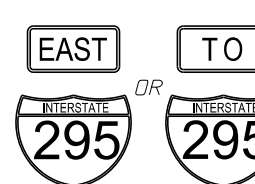
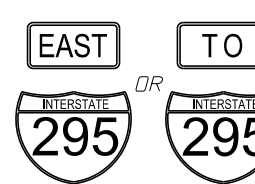
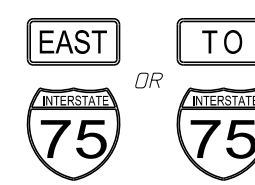
	Size	Area	Total Area	Centroid
	30x15	3.13 SF	12.44 SF	3.26 Ft.
	30x15	3.13 SF		
	30x24	3.99 SF		
	21x15	2.19 SF		
	Size	Area	Total Area	Centroid
	21x15	2.19 SF	5.39 SF	1.75 Ft.
	24x24	3.20 SF		
	Size	Area	Total Area	Centroid
	21x15	2.19 SF	6.18 SF	1.67 Ft.
	30x24	3.99 SF		
	Size	Area	Total Area	Centroid
	24x12	2.00 SF	5.20 SF	1.67 Ft.
	24x24	3.20 SF		
	Size	Area	Total Area	Centroid
	24x12	2.00 SF	5.99 SF	1.60 Ft.
	30x24	3.99 SF		
	Size	Area	Total Area	Centroid
	30x15	3.13 SF	7.12 SF	1.81 Ft.
	30x24	3.99 SF		
	Size	Area	Total Area	Centroid
	30x15	3.13 SF	10.33 SF	2.27 Ft.
	36x36	7.20 SF		

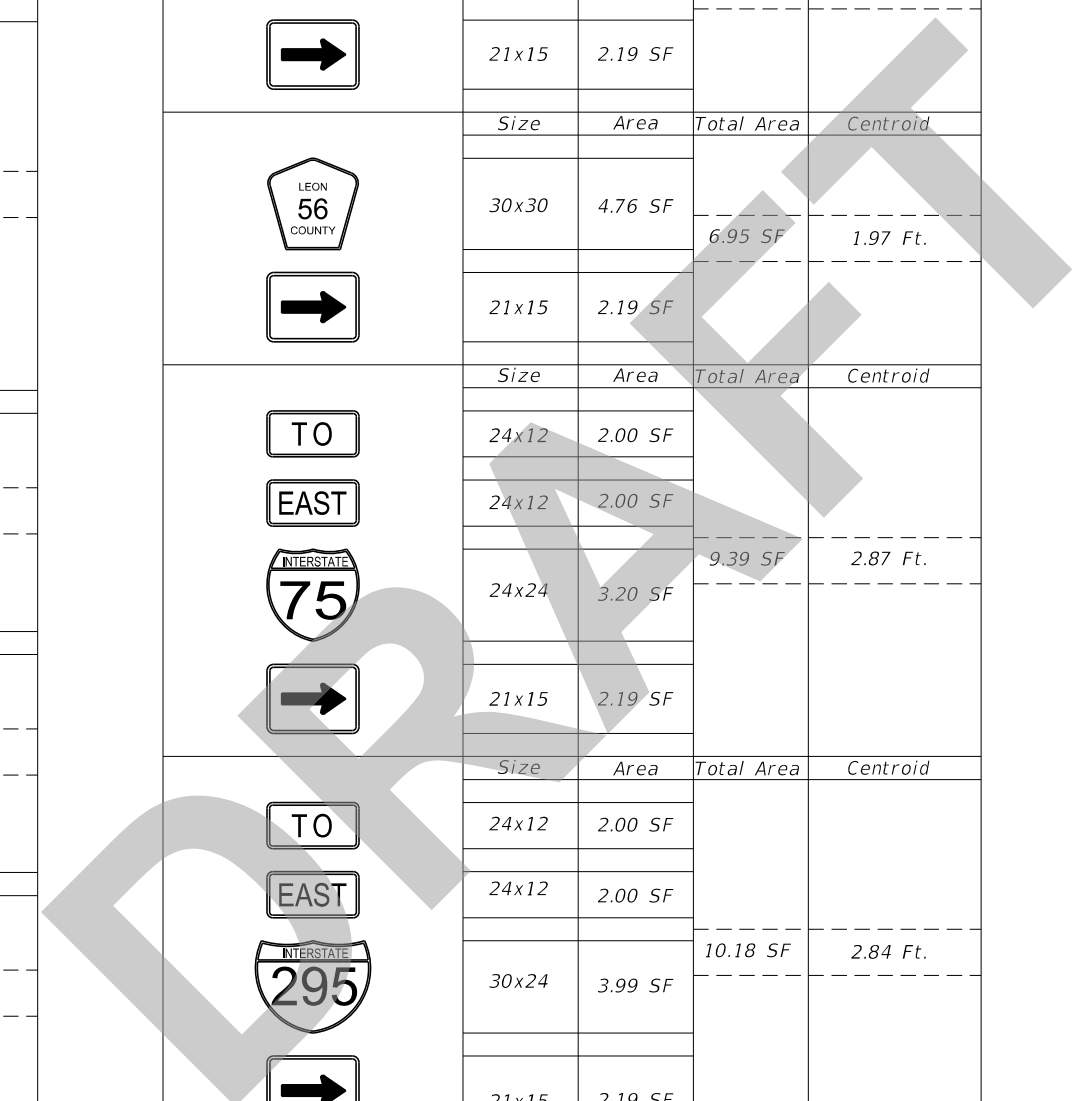

LAST REVISION 11/01/19	REVISION	DESCRIPTION:
---------------------------	----------	--------------

8/14/2019 3:02:42 PM

Size	Area	Total Area	Centroid
30x15	3.13 SF	12.12 SF	2.18 Ft.
45x36	8.99 SF		
Size	Area	Total Area	Centroid
24x12	2.00 SF	7.39 SF	2.30 Ft.
24x24	3.20 SF		
21x15	2.19 SF		
Size	Area	Total Area	Centroid
24x12	2.00 SF	8.18 SF	2.31 Ft.
30x24	3.99 SF		
21x15	2.19 SF		
Size	Area	Total Area	Centroid
30x15	3.13 SF	9.31 SF	2.55 Ft.
30x24	3.99 SF		
21x15	2.19 SF		
Size	Area	Total Area	Centroid
30x30	4.69 SF	6.69 SF	1.61 Ft.
24x12	2.00 SF		
Size	Area	Total Area	Centroid
30x30	4.69 SF	8.44 SF	1.77 Ft.
30x18	3.75 SF		
Size	Area	Total Area	Centroid
36x36	6.75 SF	10.50 SF	2.06 Ft.
30x18	3.75 SF		
Size	Area	Total Area	Centroid
30x30	6.25 SF	10.25 SF	2.74 Ft.
24x24	4.00 SF		
Size	Area	Total Area	Centroid
36x36	9.00 SF	15.25 SF	3.29 Ft.
30x30	6.25 SF		

Size	Area	Total Area	Centroid
30X30	4.69 SF	6.69 SF	1.61 Ft.
24X12	2.00 SF		
Size	Area	Total Area	Centroid
30X30	4.69 SF	8.44 SF	1.77 Ft.
30X18	3.75 SF		
Size	Area	Total Area	Centroid
36X36	6.75 SF	10.50 SF	2.06 Ft.
30X18	3.75 SF		
Size	Area	Total Area	Centroid
30X30	6.25 SF	8.25 SF	2.28 Ft.
24X12	2.00 SF		
Size	Area	Total Area	Centroid
36X36	9.00 SF	12.75 SF	2.84 Ft.
30X18	3.75 SF		
Size	Area	Total Area	Centroid
30X30	6.25 SF	10.25 SF	2.74 Ft.
24X24	4.00 SF		
Size	Area	Total Area	Centroid
36X36	9.00 SF	15.25 SF	3.29 Ft.
30X30	6.25 SF		

Size	Area	Total Area	Centroid
30X30	6.25 SF	9.25 SF	2.51 Ft.
24X18	3.00 SF		
Size	Area	Total Area	Centroid
36X36	9.00 SF	14.00 SF	3.06 Ft.
30X24	5.00 SF		

LAST REVISION 11/01/19

DESCRIPTION:



FY 2020-21  
STANDARD PLANS

SINGLE COLUMN GROUND SIGNS

INDEX  
700-010

SHEET  
10 of 10