

## Index 715-002 Standard Aluminum Lighting

### ORIGNATION

**Date:** April 2, 2018

**Name:** Andre Pavlov

**Phone:** (850) 414-4293

**Email:** andre.pavlov@dot.state.fl.us

### COMMENTARY

Sheet 1: Changed GENERAL NOTE 4.B

Sheet 2: Updated all details - deleted or revising pole dimensions.

Sheet 3: Added dual dimensions to the ARM CONNECTION DETAIL and SECTION A-A; Deleted the ARM TABLE and its notes; Changed the ARM TUBE EXTRUSIONS NOTES.

Sheet 4: Changed FOUNDATIONS Depth Requirement Depth; Added dual dimensions to the POLE BASE ELEVATION; Deleted All Tables and Added new tables; Updated the NOTES.

Sheet 5: Added dual dimensions to the BASE PLATE PLAN; Deleted the POLE TABLE; Updated NOTES.

### COMMENTS AND RESPONSES

**BLACK** = Industry Review Comments    **RED** = Standard Plans Response

**Name:** Josiah Ynacay

**Date:** September 26, 2018

#### **COMMENT:**

After reviewing the new index, we agree with the draft with a few exceptions.

In regards to the shorter mounting height poles, more specifically the 30 foot through 40 foot mounting height assemblies and one case for 45' mounting height, the combined stress ratios in your MathCAD file proves there are opportunities to use less material in the shafts' wall thicknesses.

Highlighted sections of these proposed changes to your tables are in the PDF attachment above.

The other exception we have is in regards to the tenon length in the top mounted assemblies. Our traditional casting is 4" long vs the index's 3" long. 4" length is compatible with more fixtures. We propose the image show 3"- 4" length.

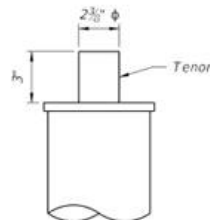

TOP MOUNT TENON

**RESPONSE:**

Based on these comments, changes to the thickness tables have been made. The Top Mount Tenon drawing has changed to show 3"-4" for length.

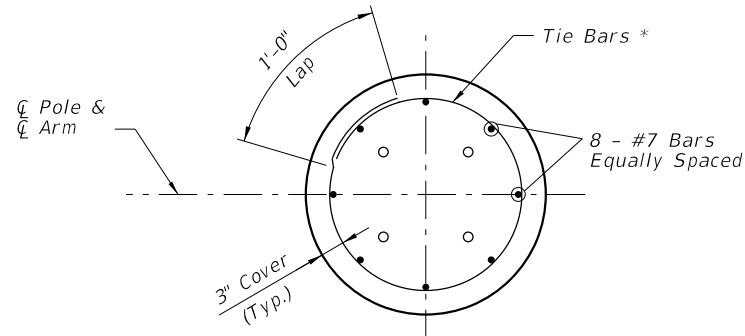

SECTION C-C

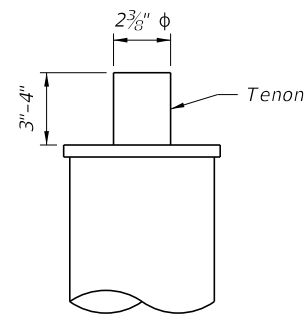

TOP MOUNT TENON

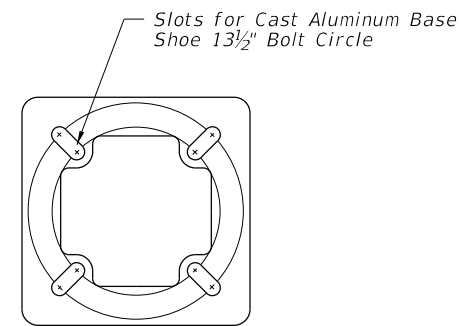

TOP VIEW TRANSFORMER BASE

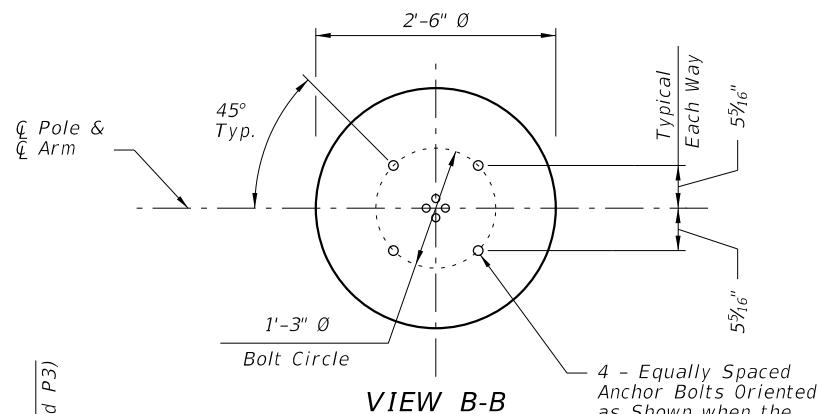

VIEW B-B

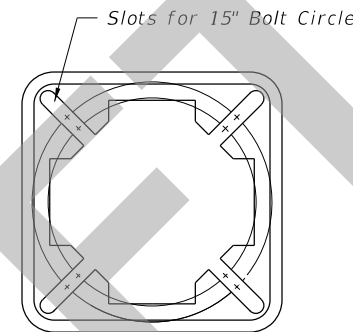

BOTTOM VIEW TRANSFORMER BASE

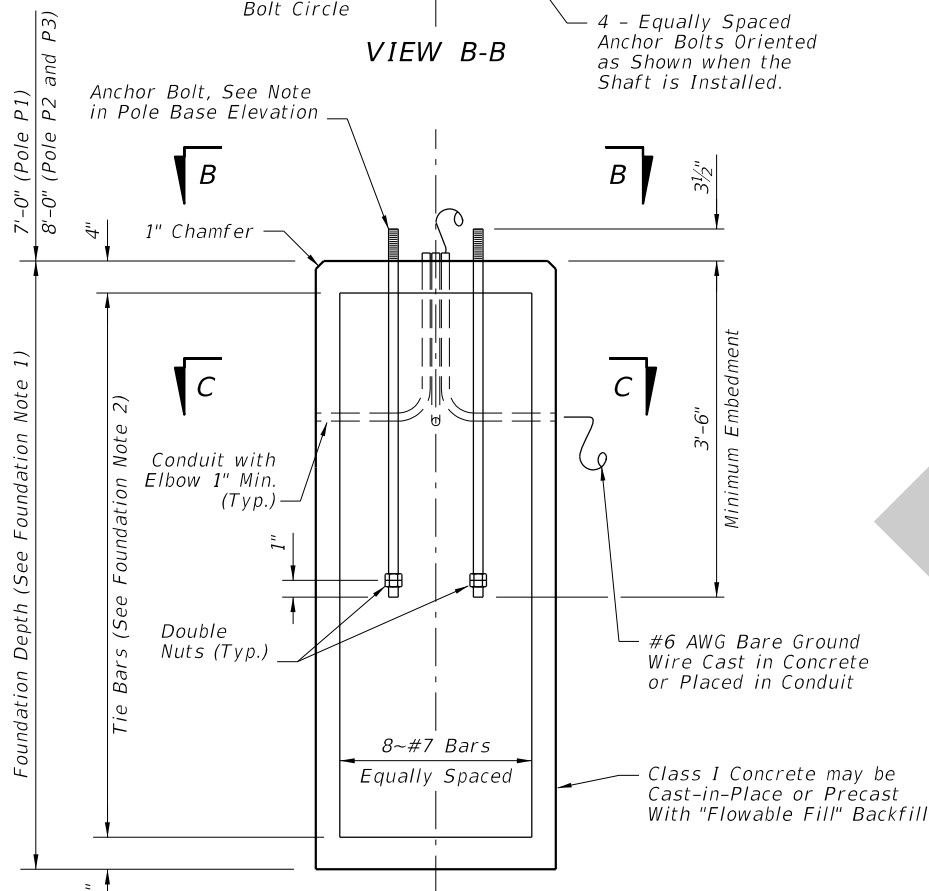

FOUNDATION NOTES:

1. Depths shown are for slopes flatter than 1:4, for slopes 1:2 or flatter, add 2'-6" to foundation depths shown.
2. Foundation Tie Bars: #4 Tie Bars @ 12" centers (max.) or D10 (or W10) spiral @ 6" pitch, 3 flat turns top and 1 flat turn bottom.

FOUNDATION

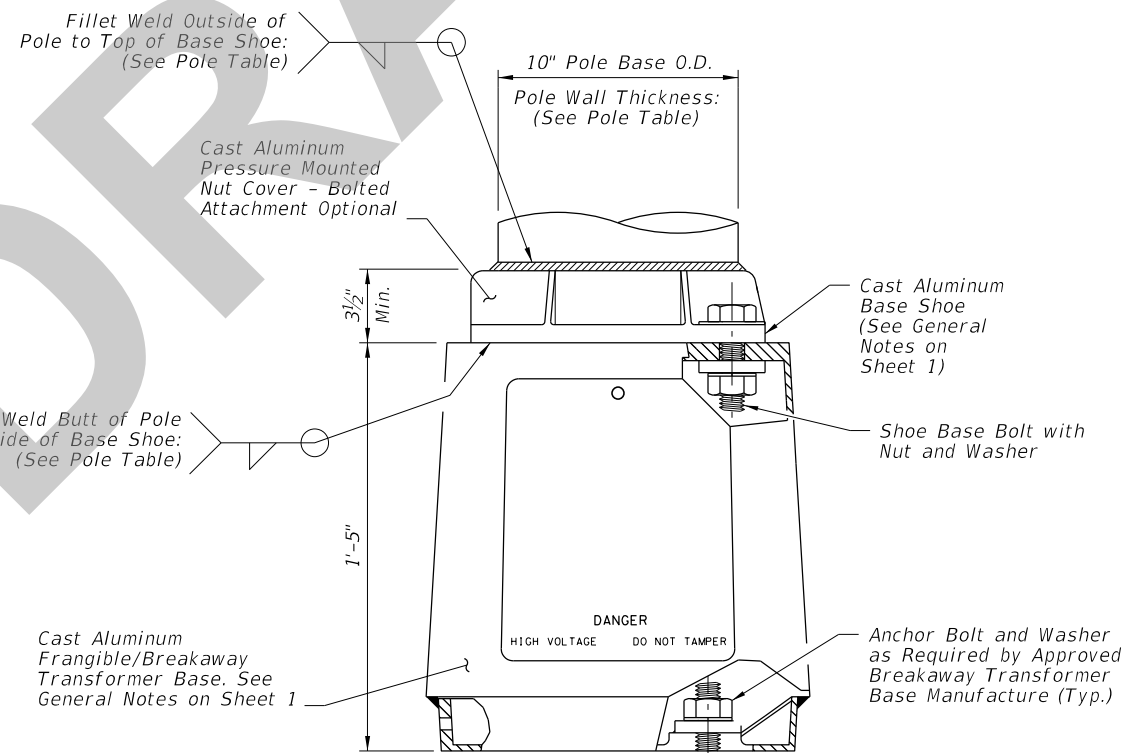

POLE BASE ELEVATION

ARM-POLE TABLE					
FOR STANDARD ALUMINUM LIGHT POLES WITH ARM					
Assembly Height (ft)	Wind Speed and Arm Lengths (ft)				
	120 mph	140 mph	160 mph		
	8, 10, 12, 15	8, 10, 12	15	8, 10	12, 15
30	A1-P1	A1-P1	A2-P1	A1-P1	A2-P1
35				A1-P2	A2-P2
40				A1-P3	A2-P3
45	A1-P2	A1-P2	A2-P2	A1-P1	A2-P1
50				A1-P2	A2-P2

ARM POLE NOTES:

1. See ARM SECTION detail on Sheet 3 for all A1 and A2 Values.
2. See Pole Table for all P1, P2, and P3 values.
3. For Median Barrier Mounted Pole, Use Arm A1.

POLE TABLE			
Pole	Pole Wall Thickness	Top of Base Shoe Weld	Inside of Base Shoe Weld
P1	0.156	3/16"	5/32"
P2	0.250	1/4"	1/4"
P3	0.313	5/16"	5/16"

POLE NOTES:

1. Pole wall thicknesses shown are nominal and must be within the Aluminum Association tolerances.
2. Thicker walls are permitted and tapered walls may be used in accordance with the minimum Aluminum Association thicknesses.

TOP MOUNT POLE TABLE			
FOR STANDARD ALUMINUM LIGHT POLES WITH TOP MOUNT			
Assembly Height (ft)	Wind Speed and Arm Lengths (ft)		
	120 mph	140 mph	160 mph
30	Pole P1	Pole P1	Pole P1
35			Pole P2
40			Pole P2
45	Pole P2	Pole P2	Pole P2
50			Pole P2

11:55:19 AM  
10/17/2018

LAST REVISION 04/03/18	DESCRIPTION:
---------------------------	--------------