

SIDE VIEW DAMPING DEVICE

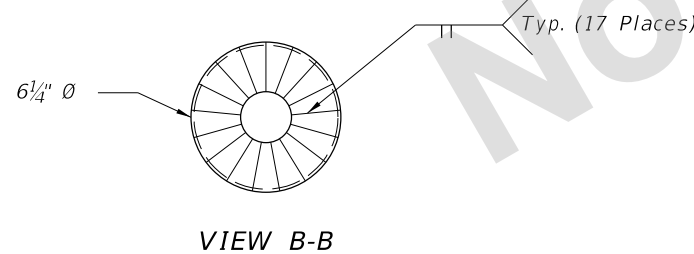

VIEW B-B

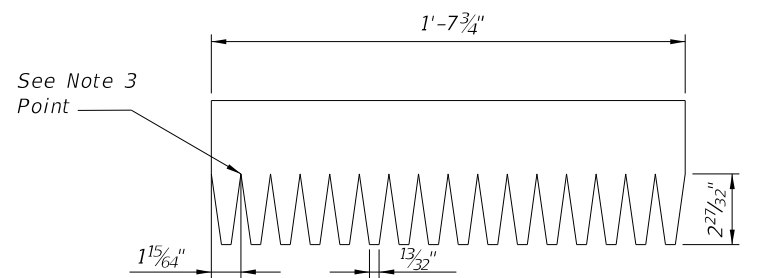

SHELL STENCIL FOR SCRIBING AND CUTTING BOTTOM TAPER FOR PART 1 (Not to Scale)

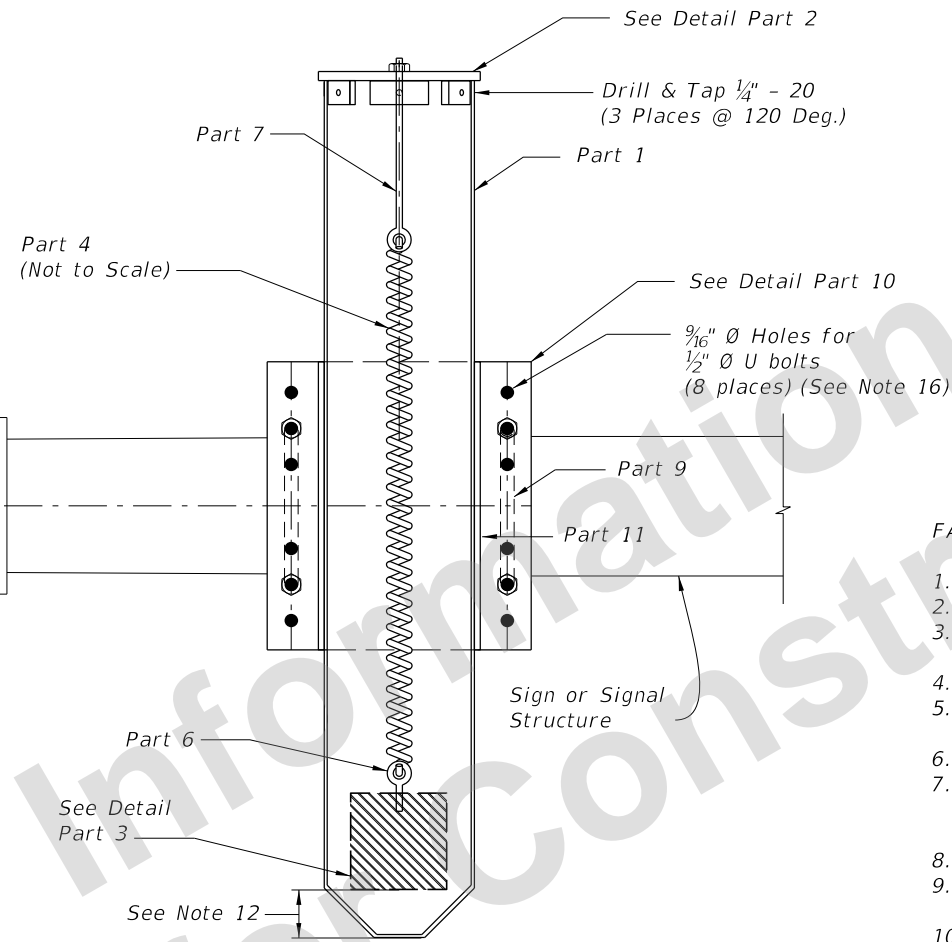

SECTION A-A

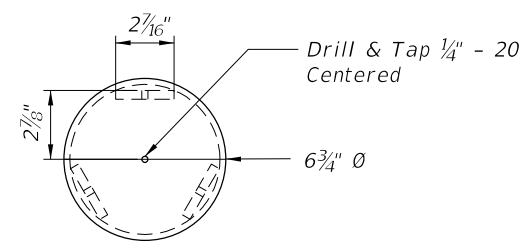

TOP VIEW

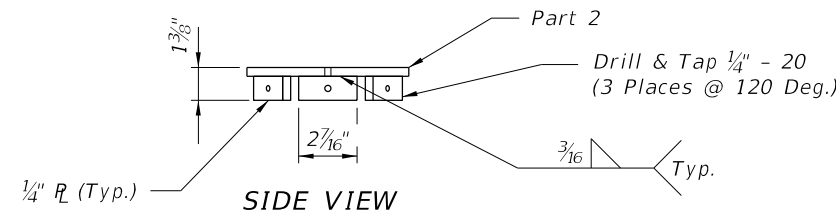

SIDE VIEW PART 2 TUBE CAP

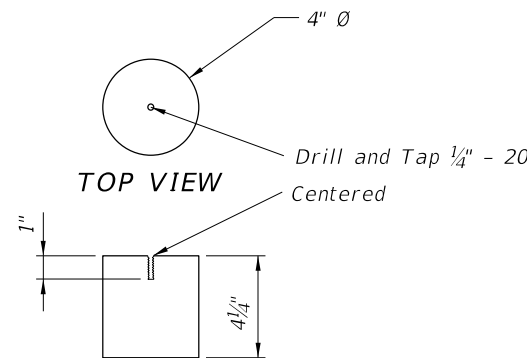

TOP VIEW PART 3 INTERNAL WEIGHT

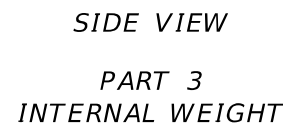

SIDE VIEW PART 3 INTERNAL WEIGHT

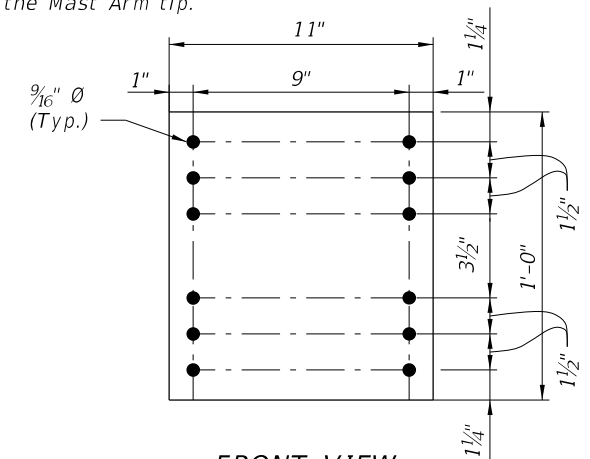

FRONT VIEW PART 10 BACKING PLATE

#	PART	PART DESCRIPTION	QUANTITY
1	Damper Tube	6" ID, 3'-6" long before fabrication, t=0.125", ASTM A513, Type 1	1
2	Tube Cap	Cap Assembly, 1/4" Steel plate, ASTM A36	1
3	Internal Weight	4" Ø, 15 Lb. cylindrical, steel weight, ASTM A36.	1
4	Damper Spring	Century Spring (Spring Stock #147) Stiffness= 0.69 Lb/in, length = 8.5", OD= 1.062"	1
5	Hex Nut	1/4" - 20 steel hex nut (zinc plated)	1
6	Eye Bolt	1/4"x2" Steel Eye Bolt (zinc plated)	1
7	Eye Bolt	1/4"x8" Steel Eye Bolt (zinc plated)	1
8	Cap Screw	#8-32x3/4 Stainless Steel Machine Screws (Flat Head Phillips)	3
9	U Bolt	1/2" Ø ASTM, A307 with washers and 4 self locking nuts (Size to fit Mast Arm)	2
10	1/4" Plate	1'-0"x11", ASTM A36	1
11	1/4" Plate	1'-0"x4 1/8" ASTM A36 (Weld to Part 1 and Part 10)	2

FABRICATION AND INSTALLATION NOTES:

1. Verify all clearances, tolerances and dimensions before fabrication.
2. Cut part 1 to 3' - 6".
3. Wrap the Shell Stencil around the bottom of part 1. Provide 2' - 9 5/8" between the top of part 1 and the points of the stencil.
4. Scribe and cut out the steel below the stencil.
5. Create the tapered portion of the shell by heating the area at the base of each flap and bend each flap inward. Each adjacent flap should be touching.
6. Weld the flaps together and grind the tapered surface smooth.
7. After welding, hot dip galvanize all steel items except screws, bolts, and nuts noted to be stainless steel or zinc plated, and the spring (Part 4). Galvanize bolts, nuts and washers in accordance with ASTM A153. Galvanize all other items in accordance with ASTM A123.
8. Create the weight assembly by inserting part 6 into the threaded hole of part 3
9. Create the cap assembly by inserting part 7 through the threaded hole of part 2 to where part 5 can be attached to part 7.
10. Create the cap/spring/weight/assembly by attaching one end of part 4 to part 7 and the other end of part 4 to part 6.
11. Lower the cap/spring/weight assembly into part 1.
12. Through the hole at the bottom of part 1, adjust part 7 on the cap assembly until the bottom of part 3 is 2" from the bottom of part 1. (Note: part 1 must be vertical when making the 2" measurement and the weight and spring combination needs to be at rest).
13. Match the holes in part 1 with those from part 2. Fasten them together with part 8 (4 places).
14. Tighten part 5 against part 2.
15. Cut off portion of part 7 remaining above part 5.
16. Choose the appropriate diameter U-bolt (Part 9) based on the structure's pipe arm diameter.
17. Install damping device within eight feet of the Mast Arm tip.

SDATES

LAST REVISION	DESCRIPTION:
05/28/14	



DEVELOPMENTAL STANDARD PLANS

DAMPING DEVICE FOR MISCELLANEOUS STRUCTURES

INDEX D659-049

SHEET 1 of 1