

PLAN VIEW (CASE 1)

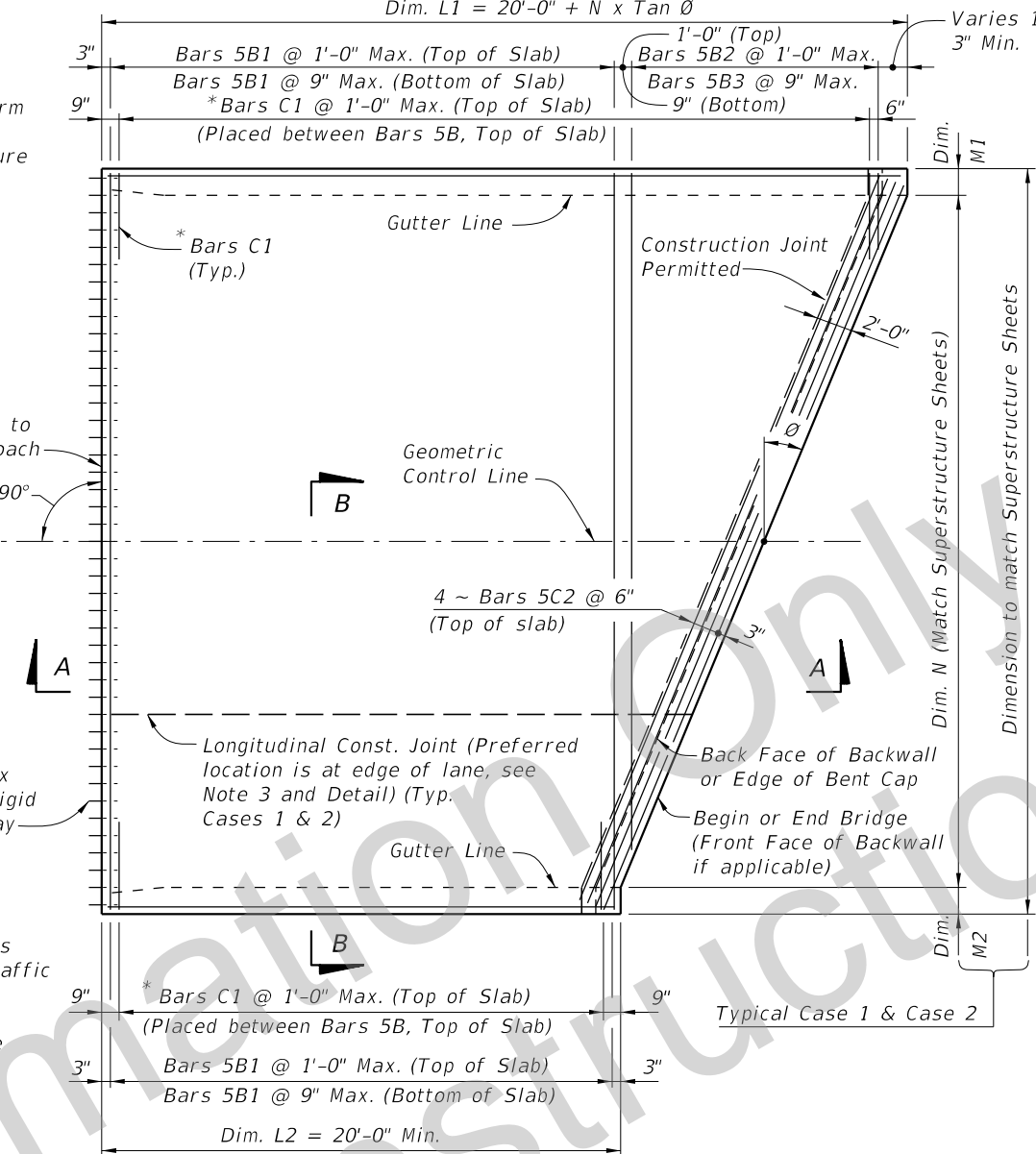

PLAN VIEW (CASE 2)

- GENERAL NOTES**
1. SURFACE TREATMENT: Apply a Class 4 Floor Finish (Grooved) to the riding surface from begin or end approach slab joint to begin or end bridge. See Bid Item Notes. Apply a broomed finish to sidewalk areas.
 2. CONDUIT: If required, see Structures Plans for Conduit details.
 3. When a longitudinal construction joint is necessary or allowed by the Engineer, the transverse steel shall be extended as shown in the Longitudinal Construction Joint Detail.
 4. The plan view for CASE 1 applies when the skew angle (θ) = 0°. Relevant details also apply to CASE 2.
 5. The plan view for CASE 2 applies where the skew angle (θ) is > 0°. The slab shown represents a skew to the right for an approach slab at begin bridge; approach slab at the end of bridge or a left skew shall be treated similarly. The shown reinforcement shall be utilized, and Dowels provided in accordance with Index 305 and 306.
 6. Deformed WWR must meet the requirements of Specification Section 931.
 7. PROFILOGRAPH: If profilograph requirements apply, planing may be required. The permitted construction joint shown in Section A-A will facilitate the placement of the expansion joint.
 8. Approach slabs shown in Plan View Cases 1 and 2 represent a typical approach slab with edge barriers and no sidewalks. Provide railings, parapets, traffic separators and sidewalks as detailed on the additional approach slab sheets.
 9. PAYMENT: Deformed WWR for the edge of Approach Slabs on retaining walls is not included in the estimated quantity for reinforcing steel and is considered incidental to the work. See Roadway Plans for Optional Base details and quantities.

CROSS REFERENCES:

For Section B-B, Longitudinal Construction Joint Detail and Approach Slab Details see Sheet 2.

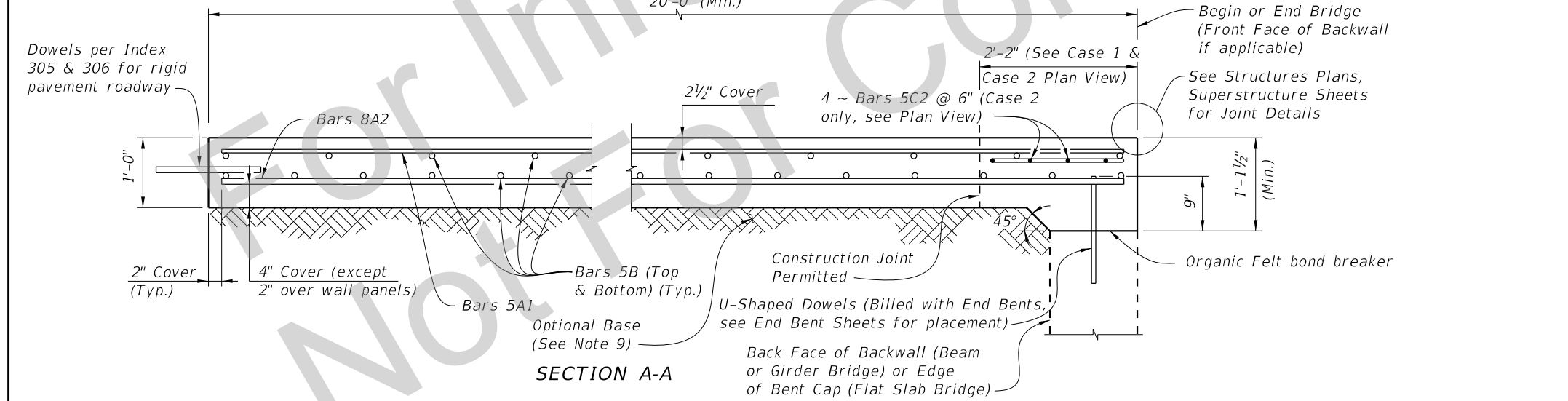

SECTION A-A

LAST REVISION 10/01/16	DESCRIPTION:		DEVELOPMENTAL STANDARD PLANS	APPROACH SLABS (20 FT.) (RIGID PAVEMENT APPROACHES)	INDEX	SHEET
					D400-093	1 of 2

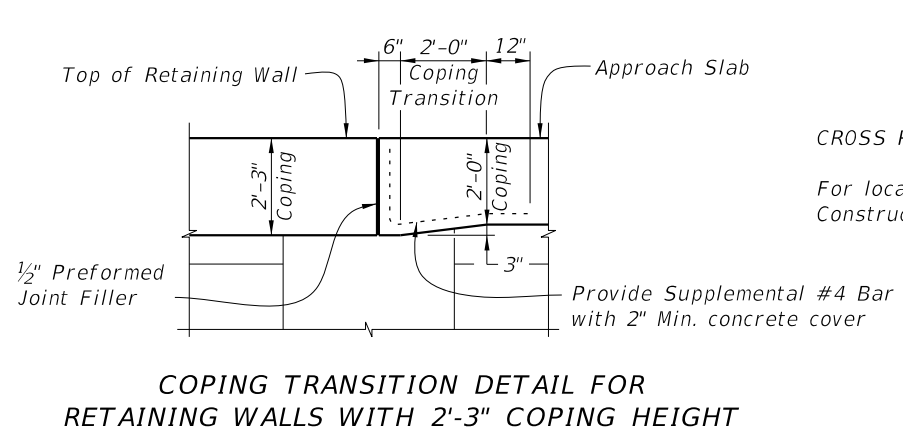
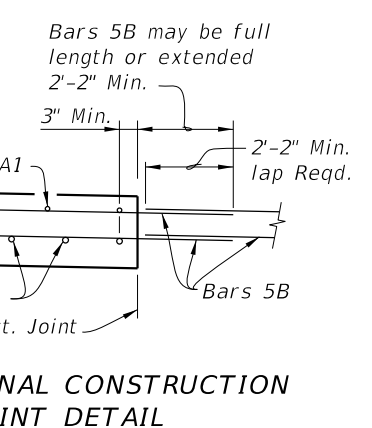
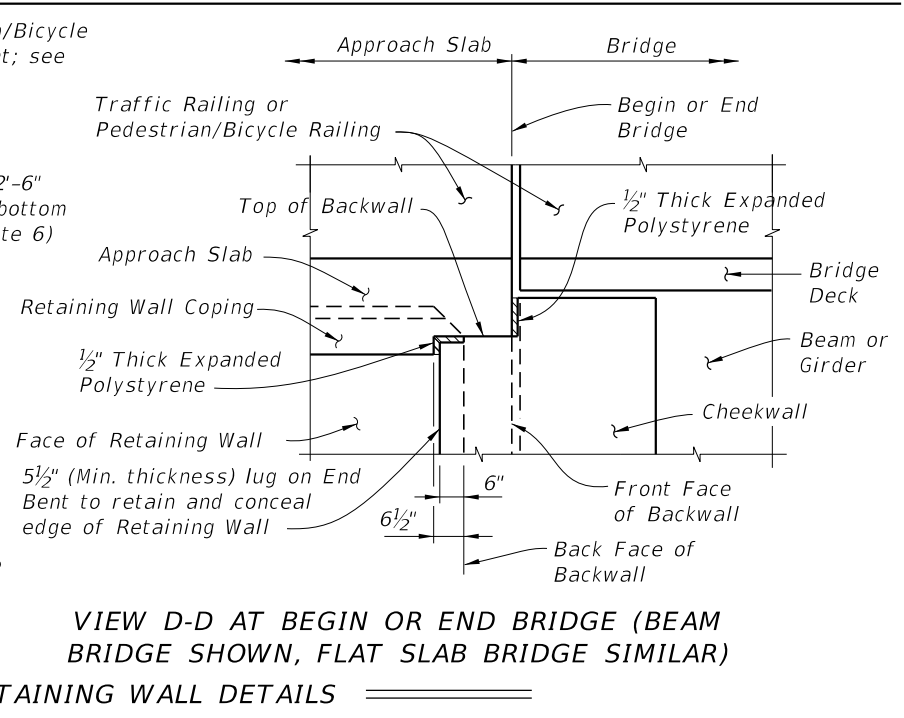
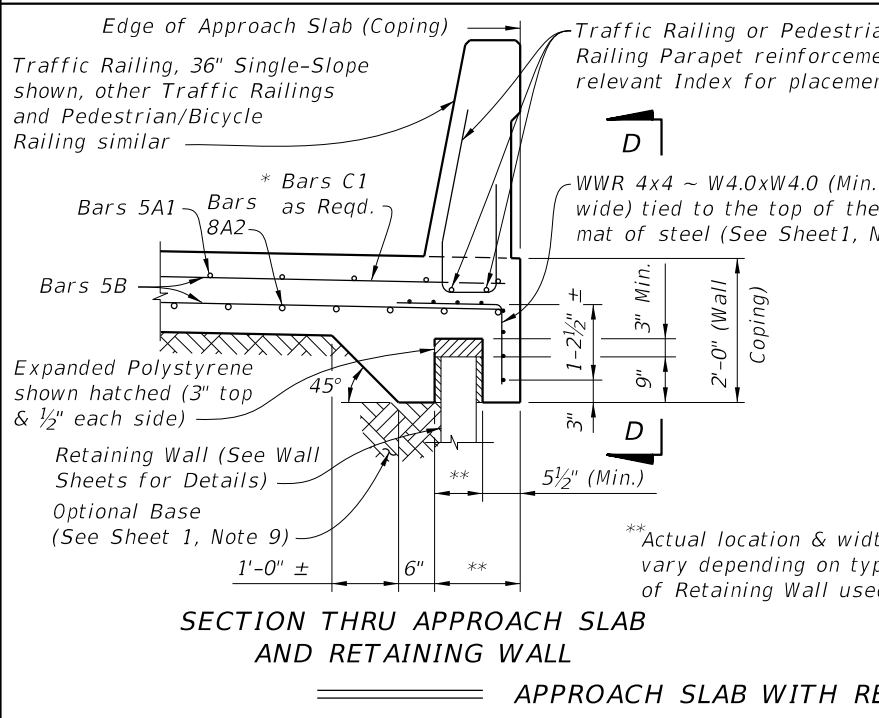
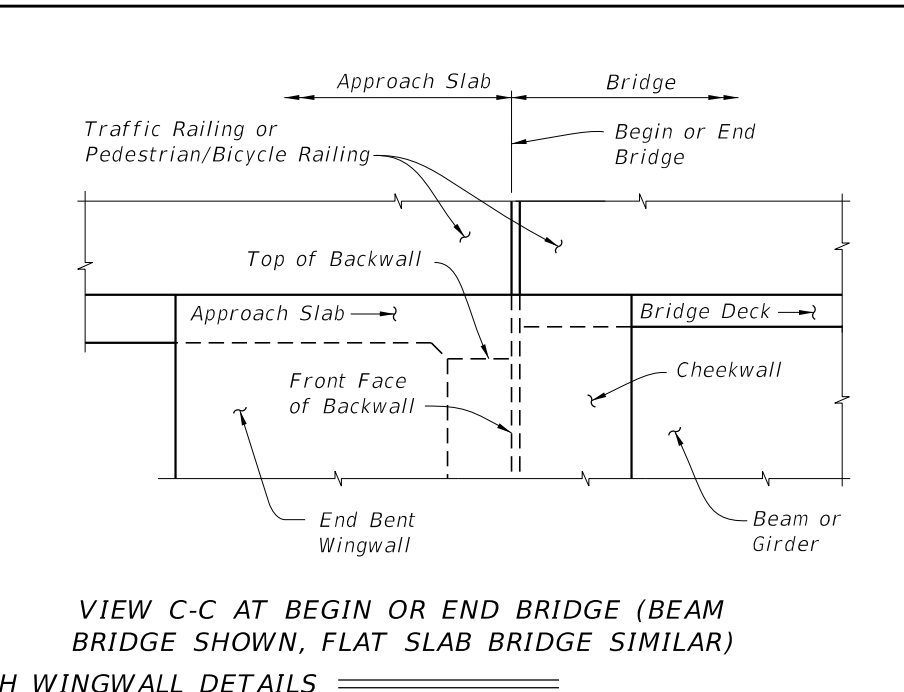
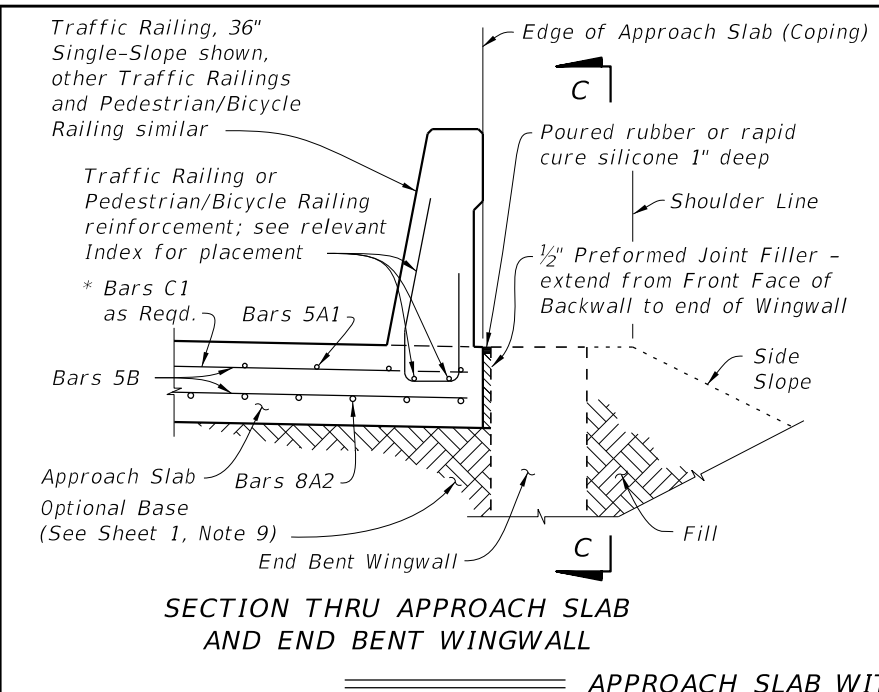
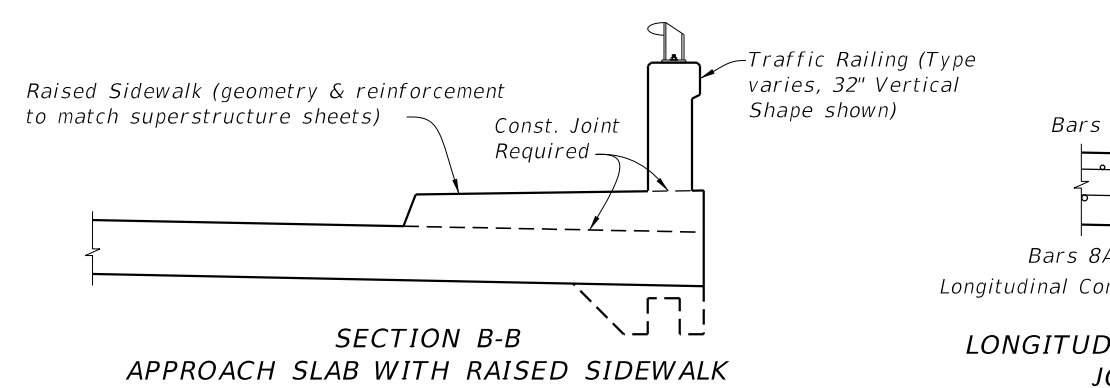
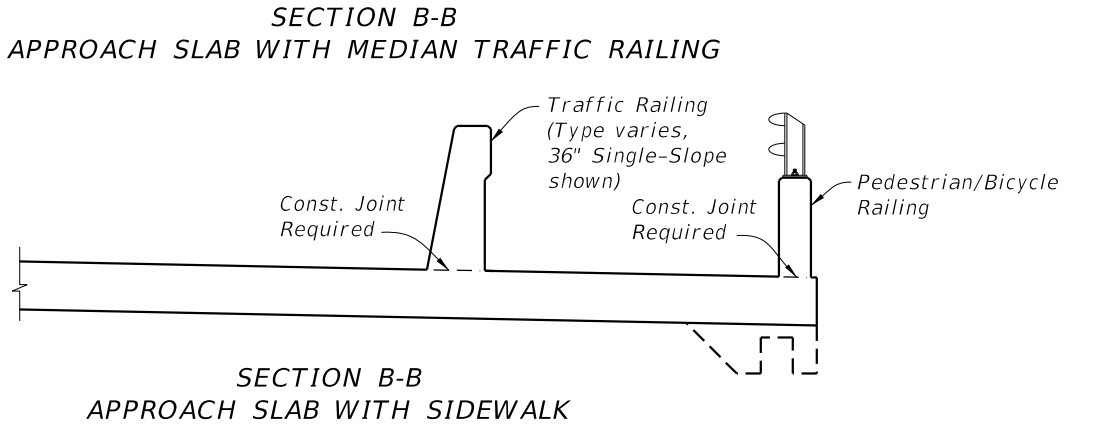
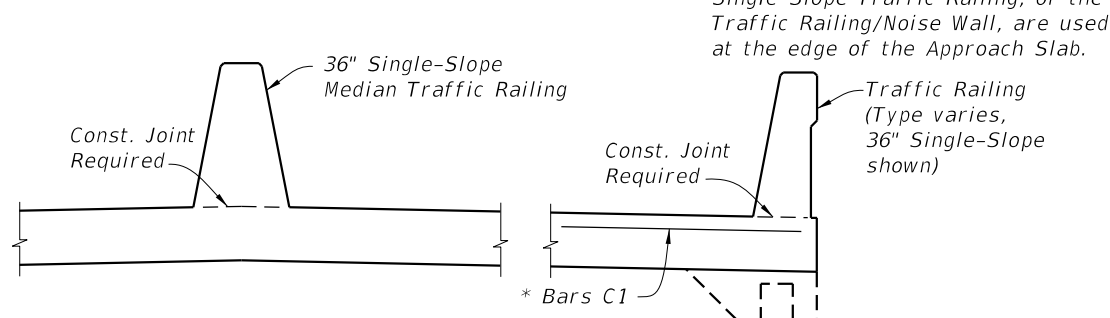
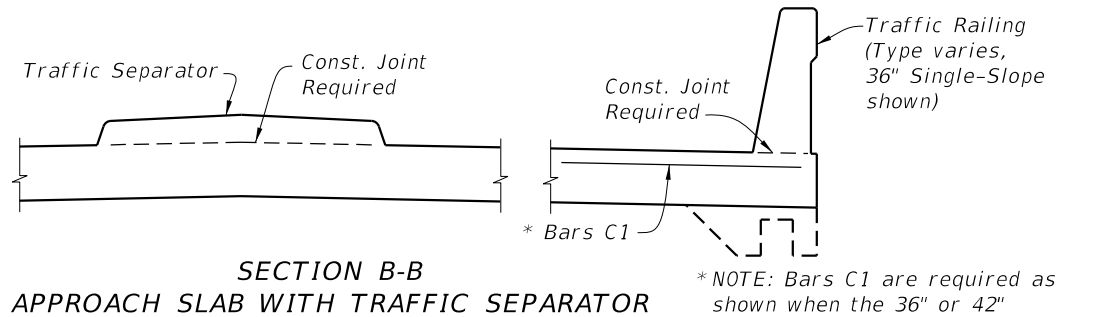
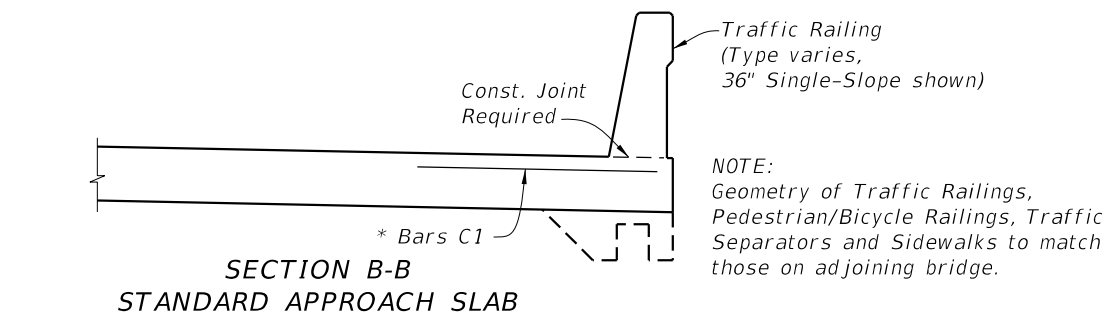

CROSS REFERENCES:
For location of Section B-B and Longitudinal Construction Joint see Sheet 1.

SDATES

LAST REVISION 06/01/18	REVISION	DESCRIPTION:
---------------------------	----------	--------------



**APPROACH SLABS (20 FT.)
(RIGID PAVEMENT APPROACHES)**

INDEX D400-093	SHEET 2 of 2
-------------------	-----------------